

Status: This is the original version (as it was originally made). This item of legislation is currently only available in its original format.

SCHEDULE 5

Commission delegated regulations related to energy labelling: updated labels

6.—(1) In Commission Delegated Regulation (EU) No 626/2011 of 4 May 2011 supplementing Directive 2010/30/EU of the European Parliament and of the Council with regard to energy labelling of air conditioners, Annex 3 (the label) is amended as follows.

(2) In paragraph 1.4 (reversible air conditioners classified in energy efficiency classes A+++ to D), for the label image, substitute the following image—

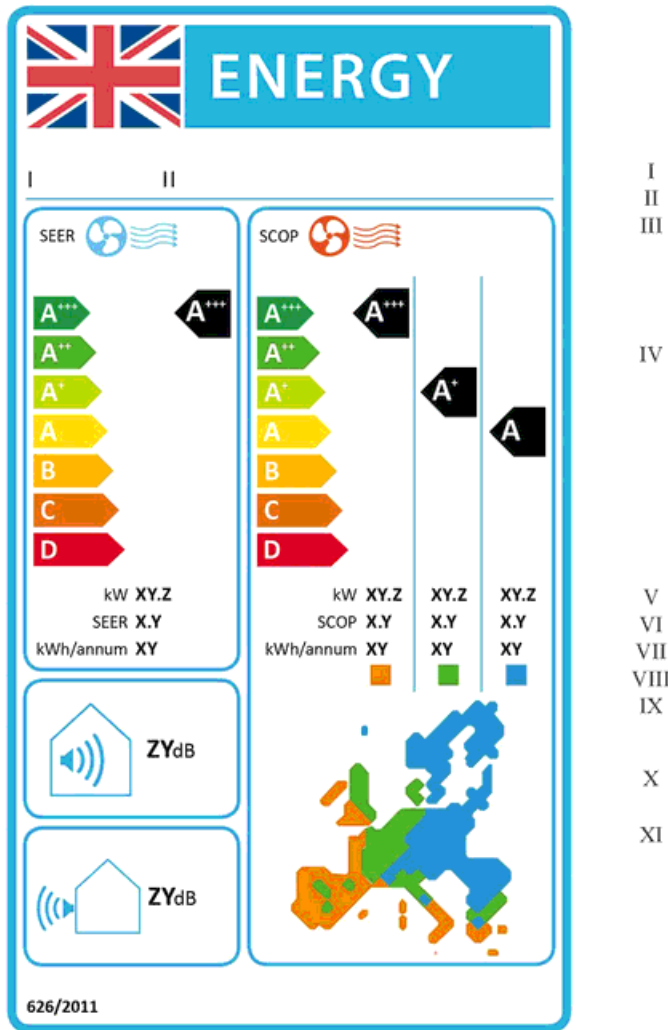

(3) In paragraph 1.5 (label design), for the label image, substitute the following image—

Status: This is the original version (as it was originally made). This item of legislation is currently only available in its original format.

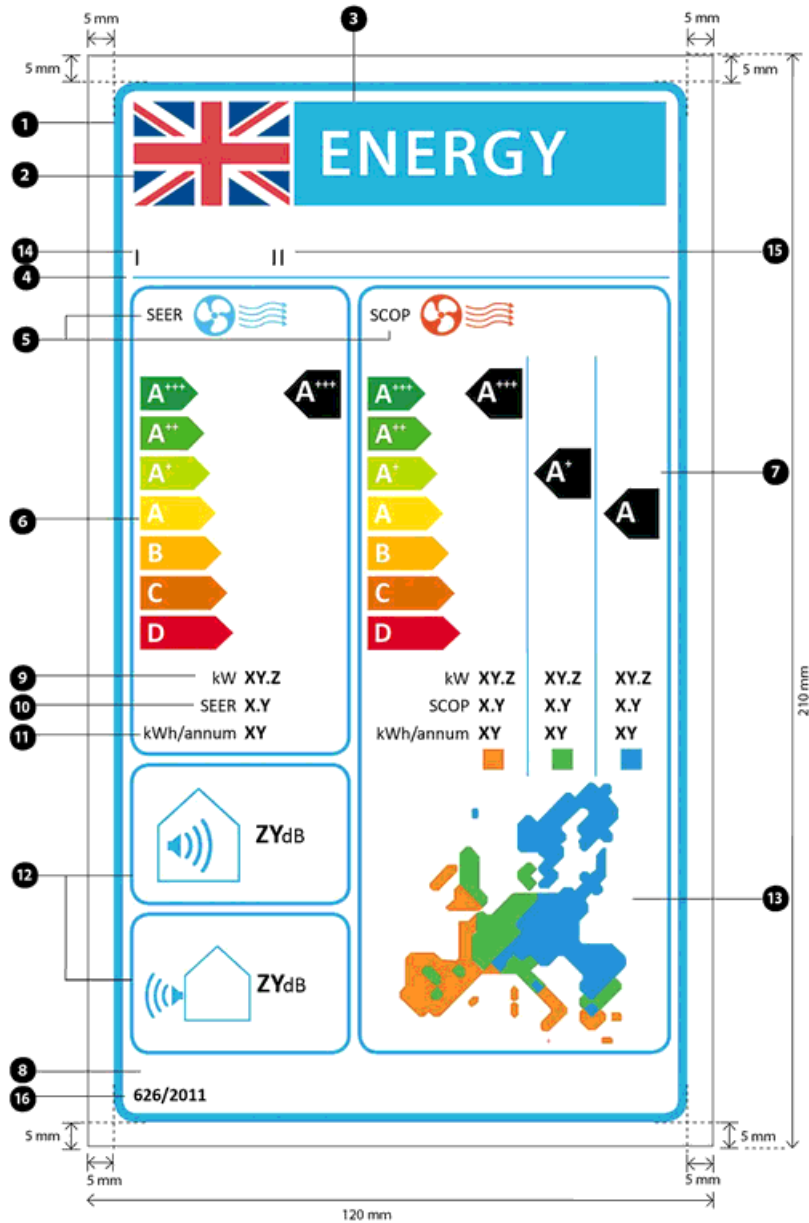

(4) In paragraph 2.4 (cooling-only air conditioners classified in energy efficiency classes A+++ to D), for the label image, substitute the following image—

Status: This is the original version (as it was originally made). This item of legislation is currently only available in its original format.

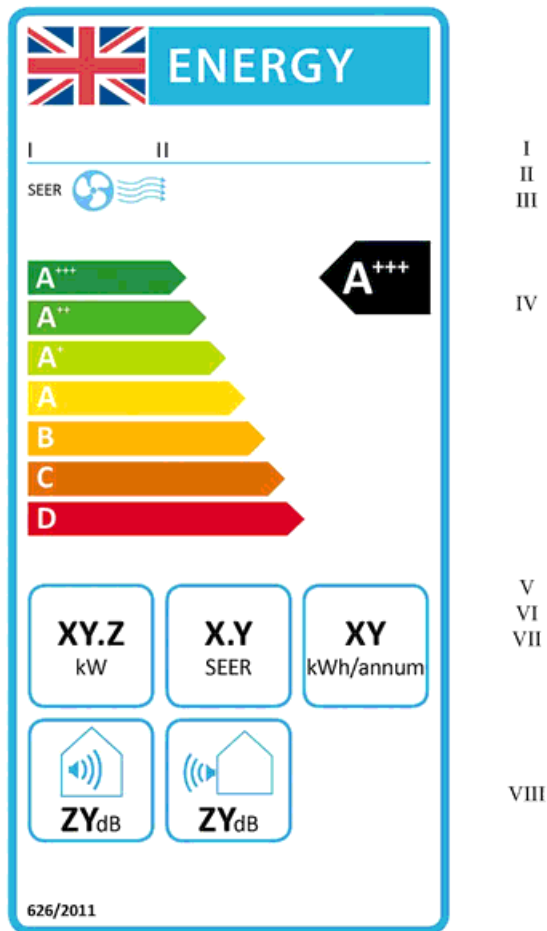

(5) In paragraph 2.5 (label design), for the label image, substitute the following image—

Status: This is the original version (as it was originally made). This item of legislation is currently only available in its original format.

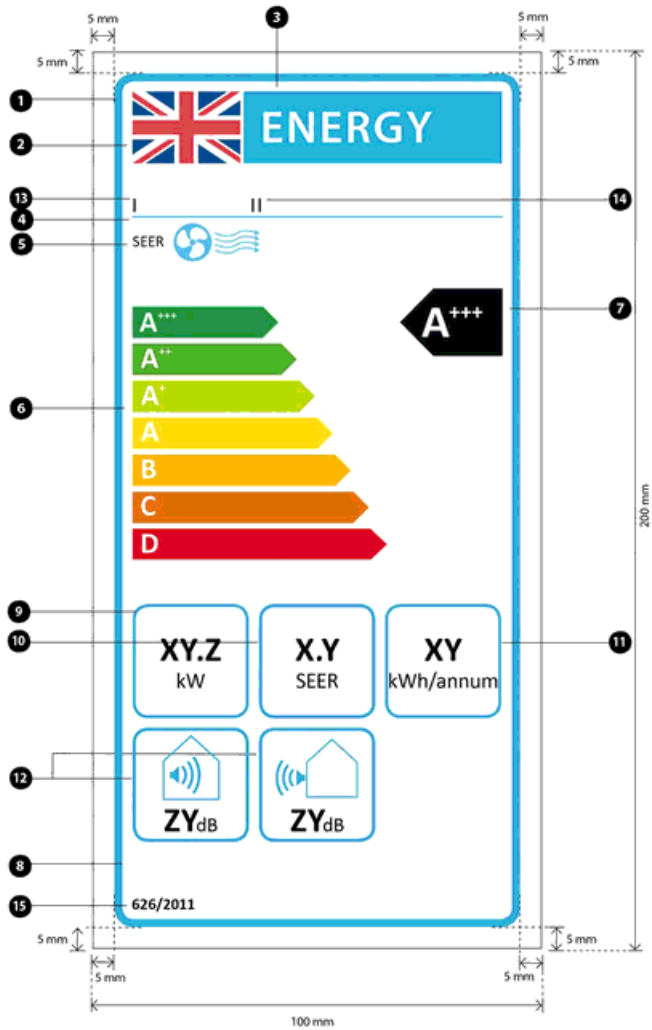

(6) In paragraph 3.4 (heating-only air conditioners classified in energy efficiency classes A+++ to D), for the label image, substitute the following image—

Status: This is the original version (as it was originally made). This item of legislation is currently only available in its original format.

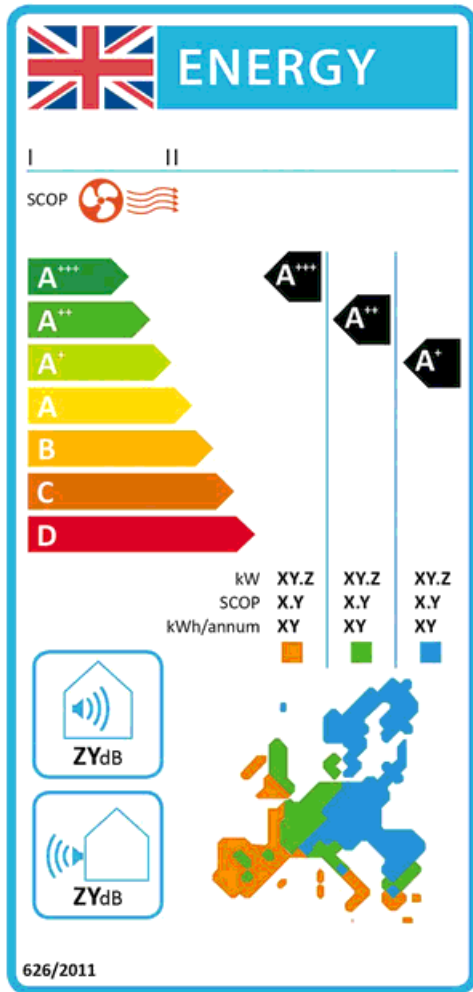

I
II
III

IV

V
VI
VII

VIII

IX

(7) In paragraph 3.5 (label design), for the label image, substitute the following image—

Status: This is the original version (as it was originally made). This item of legislation is currently only available in its original format.

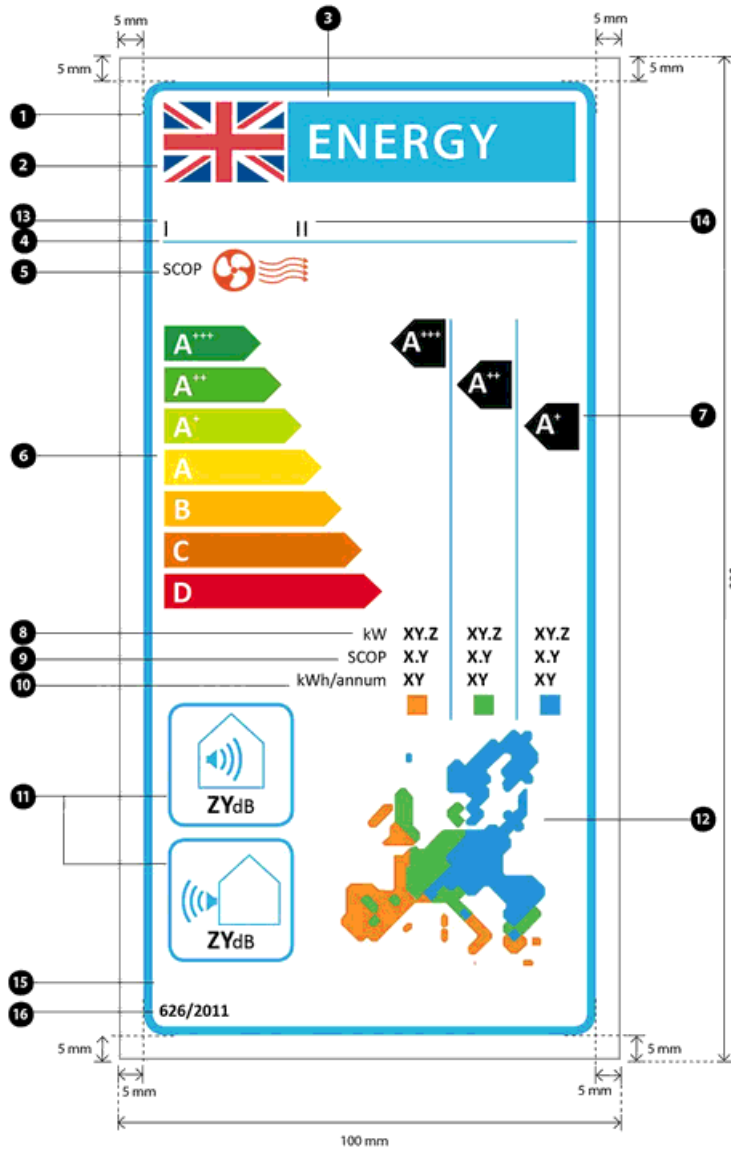

(8) In paragraph 4.1 (reversible double duct air conditioners classified in energy efficiency classes A+++ to D), for the label image, substitute the following image—

Status: This is the original version (as it was originally made). This item of legislation is currently only available in its original format.

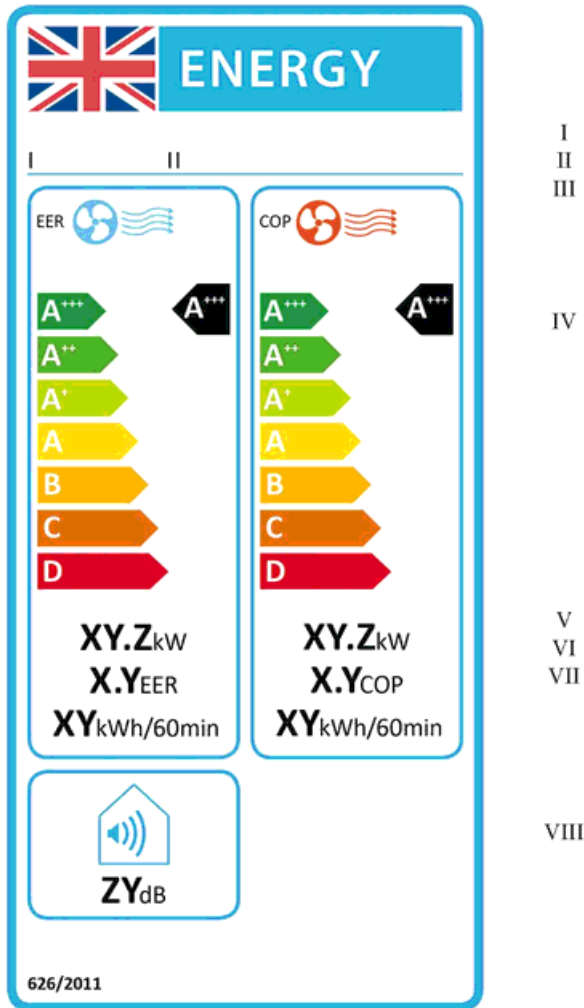

(9) In paragraph 4.2 (label design), for the label image, substitute the following image—

Status: This is the original version (as it was originally made). This item of legislation is currently only available in its original format.

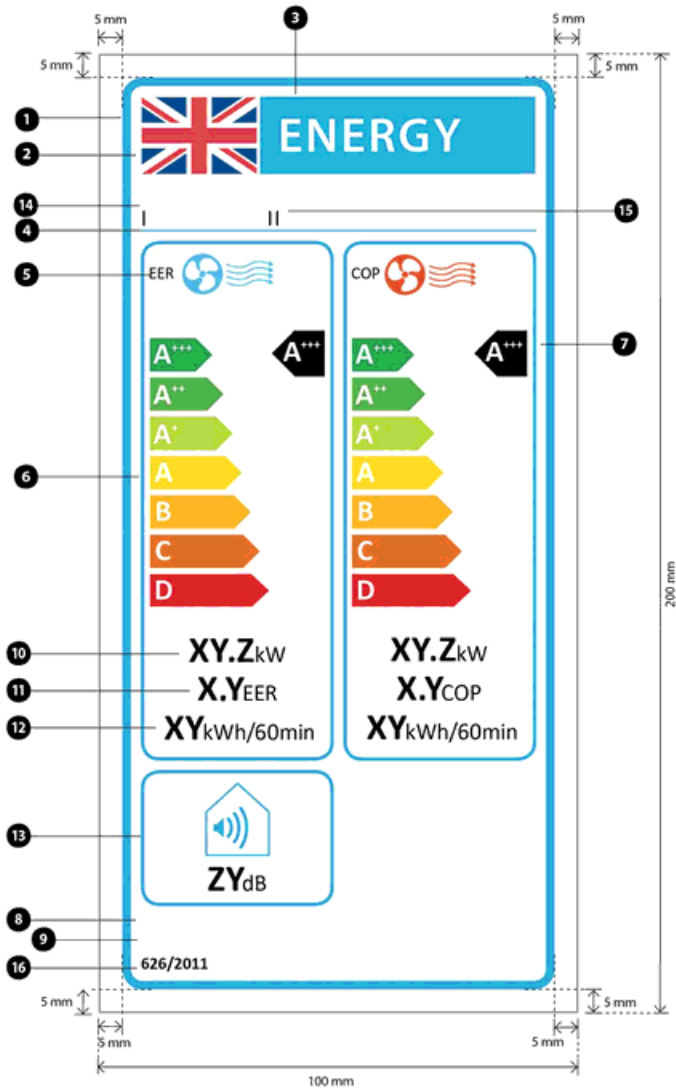

(10) In paragraph 4.3 (cooling-only double duct air conditioners classified in energy efficiency classes A+++ to D), for the label image, substitute the following image—

Status: This is the original version (as it was originally made). This item of legislation is currently only available in its original format.

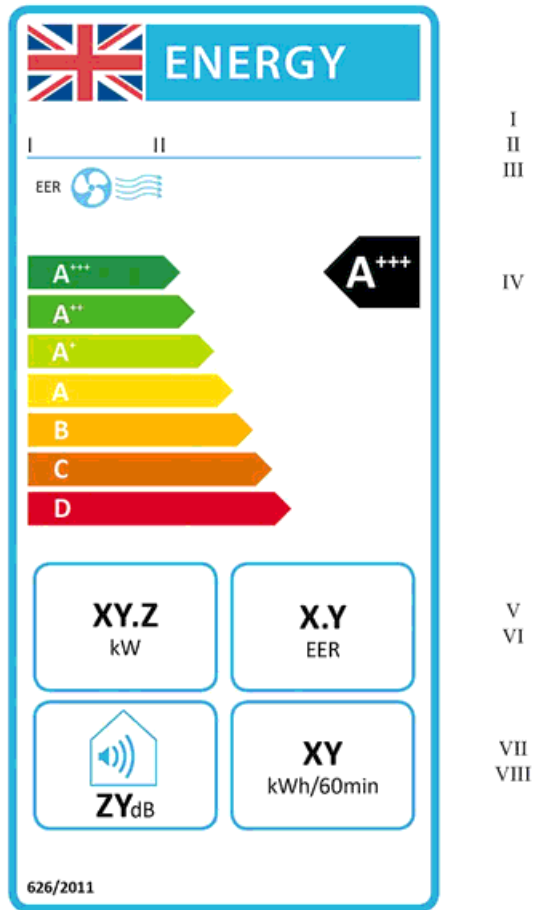

(11) In paragraph 4.4 (label design), for the label image, substitute the following image—

Status: This is the original version (as it was originally made). This item of legislation is currently only available in its original format.

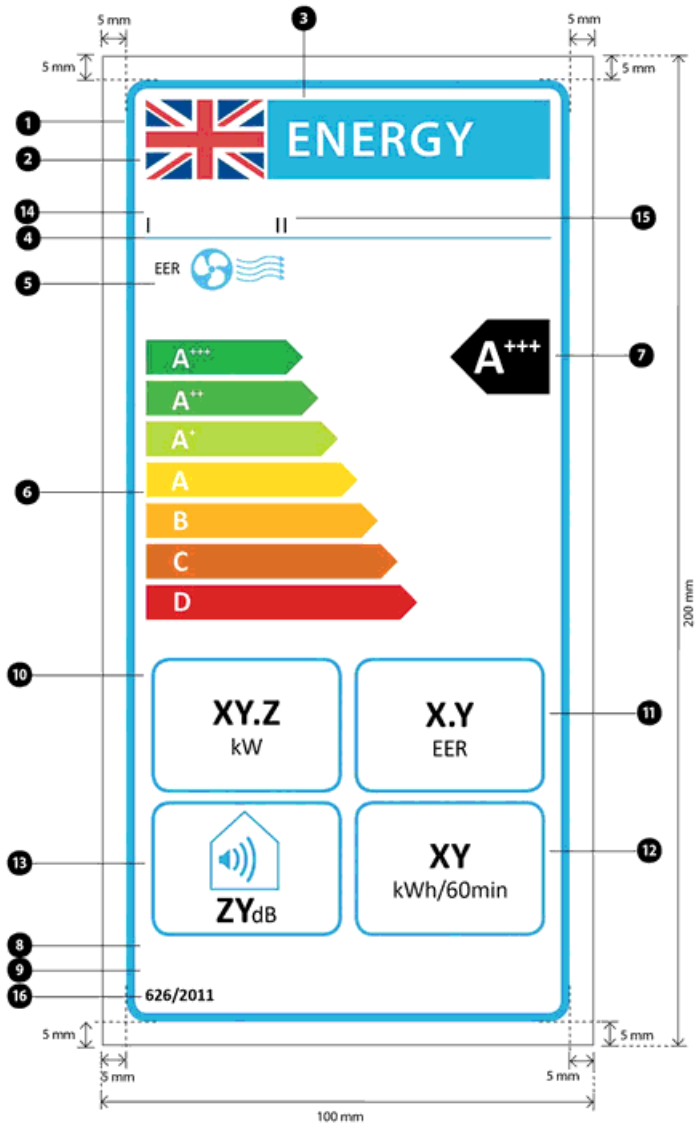

(12) In paragraph 4.5 (heating-only double duct air conditioners classified in energy efficiency classes A+++ to D), for the label image, substitute the following image—

Status: This is the original version (as it was originally made). This item of legislation is currently only available in its original format.

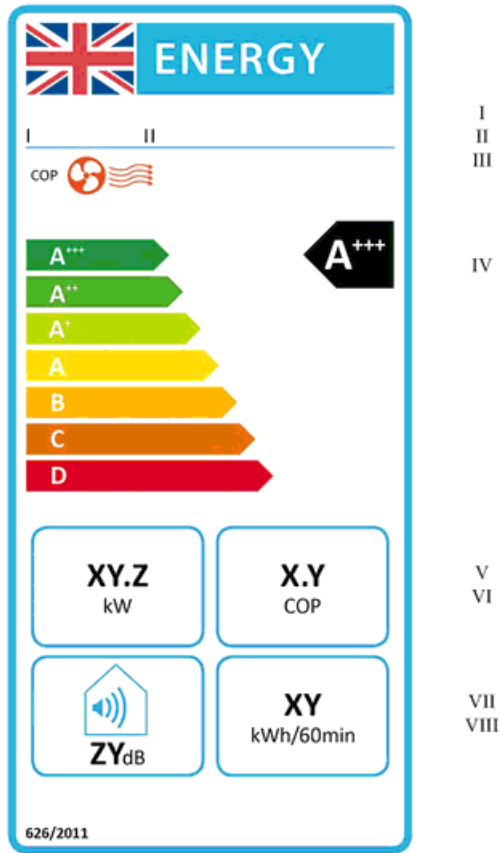

(13) In paragraph 4.6 (label design), for the label image, substitute the following image—

Status: This is the original version (as it was originally made). This item of legislation is currently only available in its original format.

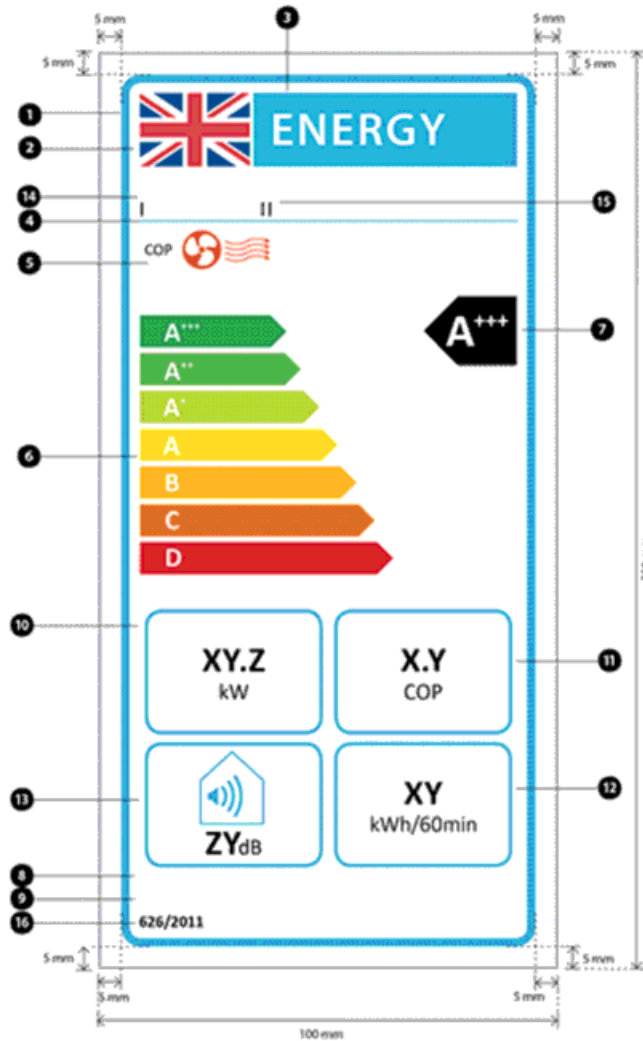

(14) In paragraph 5.1 (reversible single duct air conditioners classified in energy efficiency classes A+++ to D), for the label image, substitute the following image—

Status: This is the original version (as it was originally made). This item of legislation is currently only available in its original format.

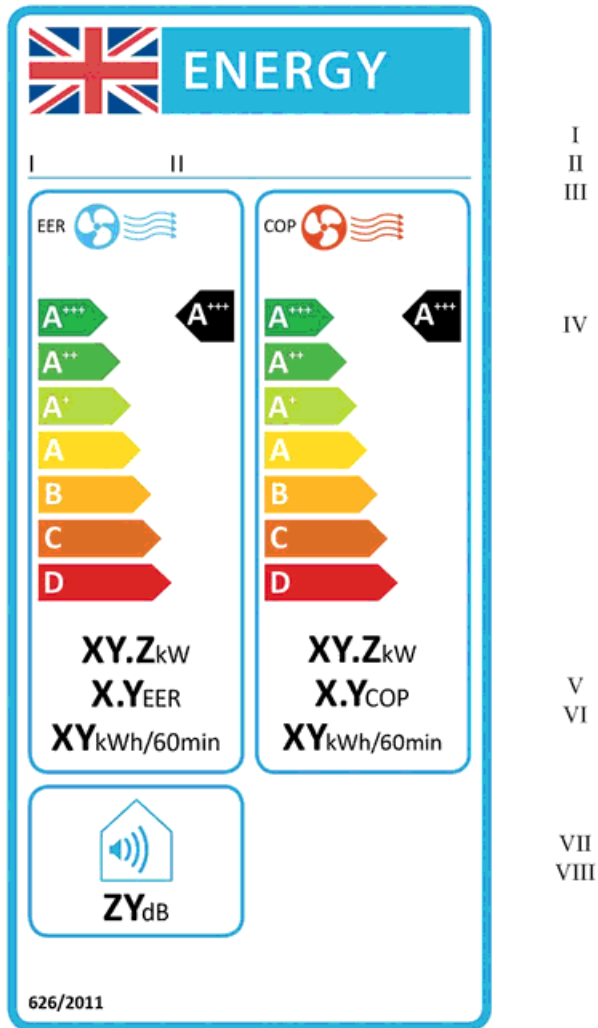

(15) In paragraph 5.2 (label design), for the label image, substitute the following image—

Status: This is the original version (as it was originally made). This item of legislation is currently only available in its original format.

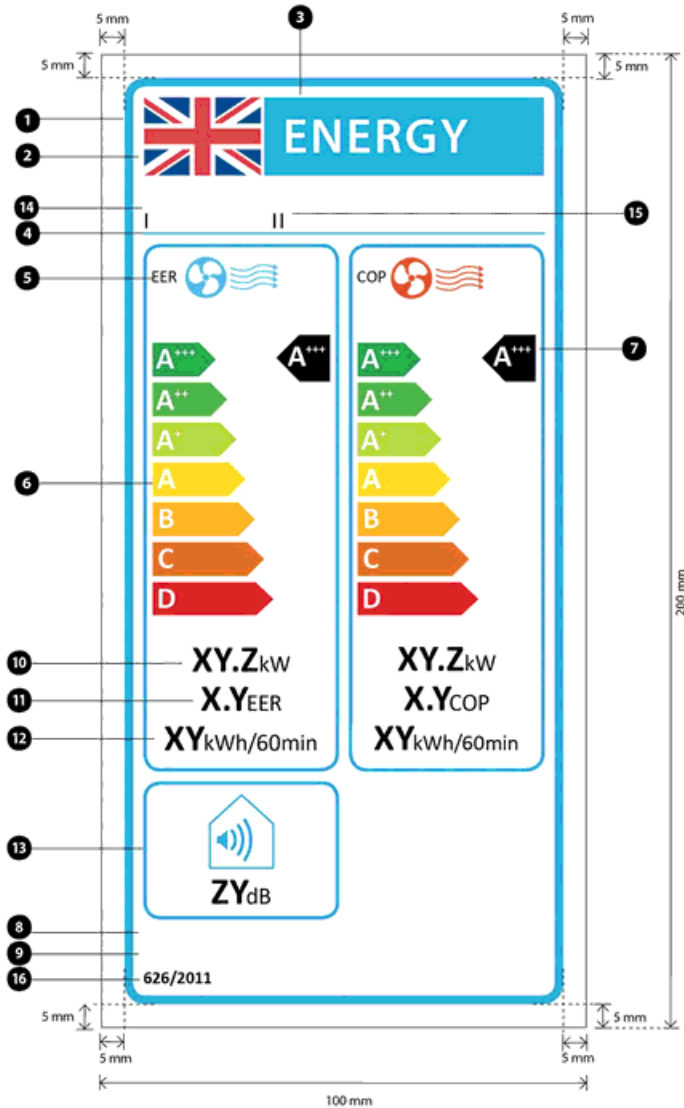

(16) In paragraph 5.3 (cooling-only single duct air conditioners classified in energy efficiency classes A+++ to D), for the label image, substitute the following image—

Status: This is the original version (as it was originally made). This item of legislation is currently only available in its original format.

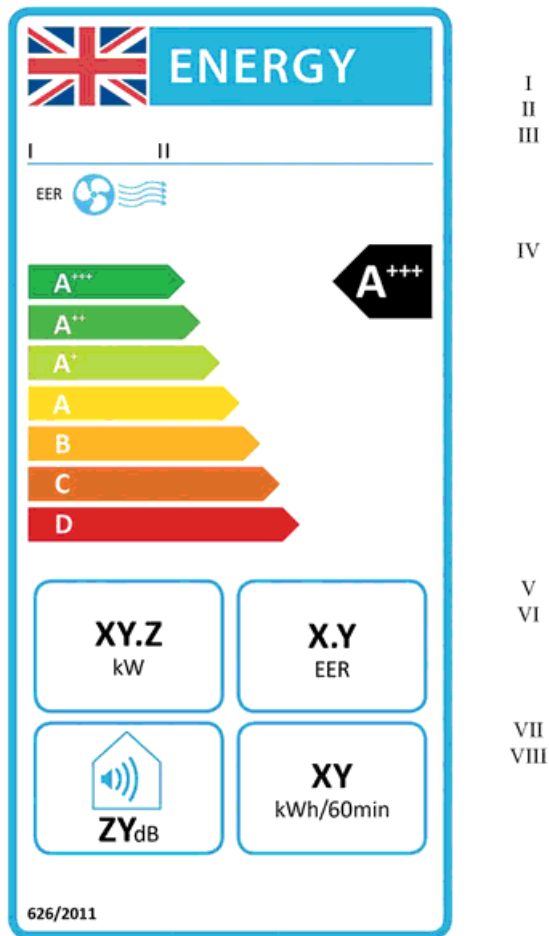

(17) In paragraph 5.4 (label design), for the label image, substitute the following image—

Status: This is the original version (as it was originally made). This item of legislation is currently only available in its original format.

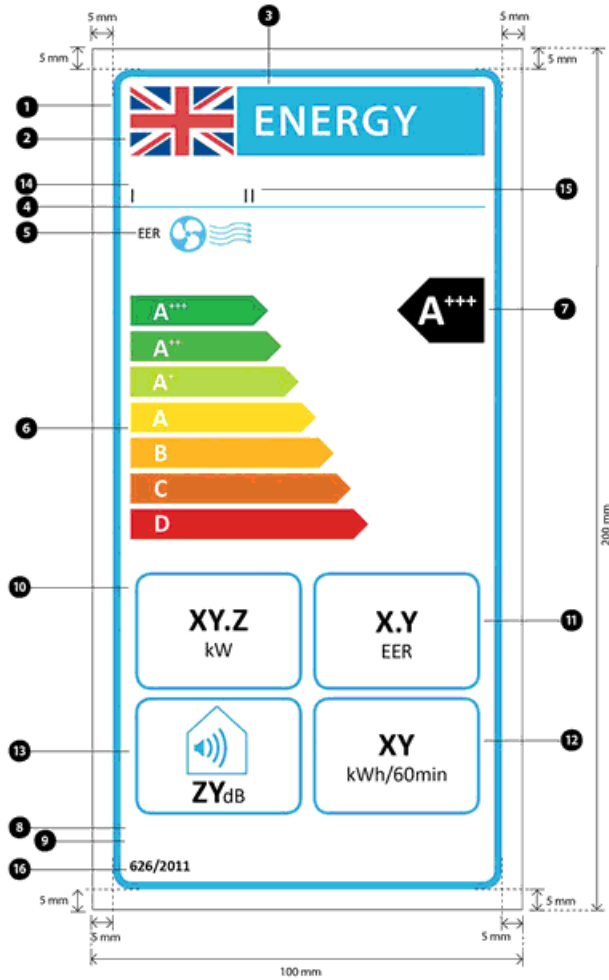

(18) In paragraph 5.5 (heating-only single duct air conditioners classified in energy efficiency classes A+++ to D), for the label image, substitute the following image—

Status: This is the original version (as it was originally made). This item of legislation is currently only available in its original format.

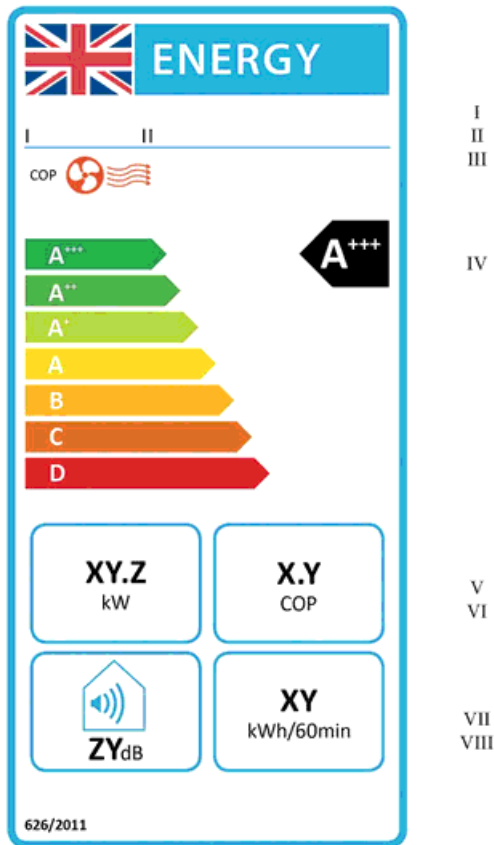

(19) In paragraph 5.6 (label design), for the label image, substitute the following image—

Status: This is the original version (as it was originally made). This item of legislation is currently only available in its original format.

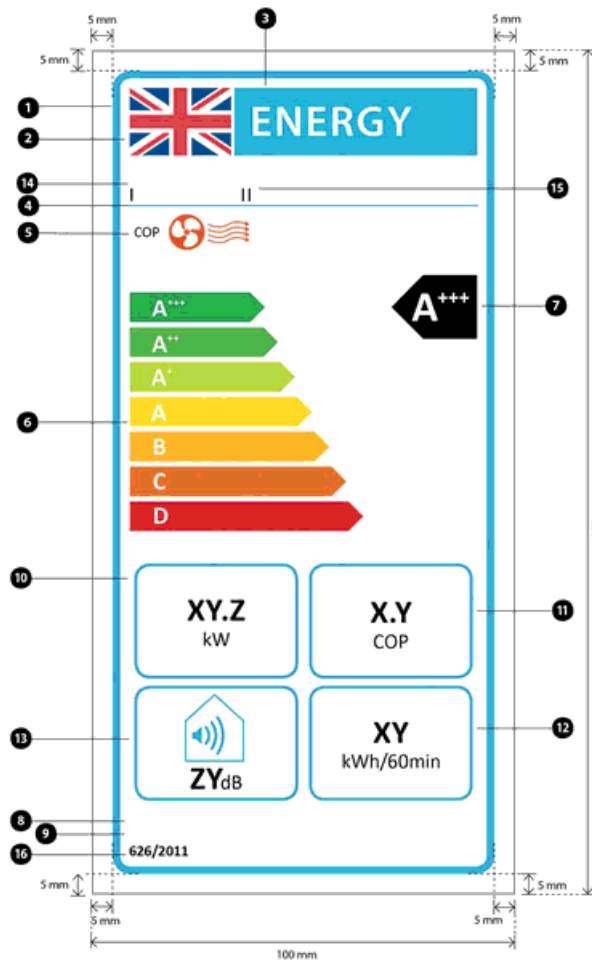

(20) In each of subparagraphs 1.5(iv), 2.5(iv), 3.5(iv), 4.2(iv), 4.4(iv), 4.6(iv), 5.2(iv), 5.4(iv) and 5.6(iv)—

(a) for point 2, substitute—

“UK flag: colours—

the blue background: 100,72,00,18.5;

the red crosses: 00,100,81,4

the remaining part: 100% white;”;

(b) in point 3, for “EU logo” substitute “UK flag”.