

SCHEDULE 5

Regulation 33

Commission delegated regulations related to energy labelling: updated labels

1. The Commission delegated regulations related to energy labelling specified in this Schedule are amended as follows.

2.—(1) In Commission Delegated Regulation (EU) No 1059/2010 of 28 September 2010 supplementing [Directive 2010/30/EU](#) of the European Parliament and of the Council with regard to energy labelling of household dishwashers, Annex 1 (label) is amended as follows.

(2) In paragraph 1 (label), for the label image, substitute the following image—

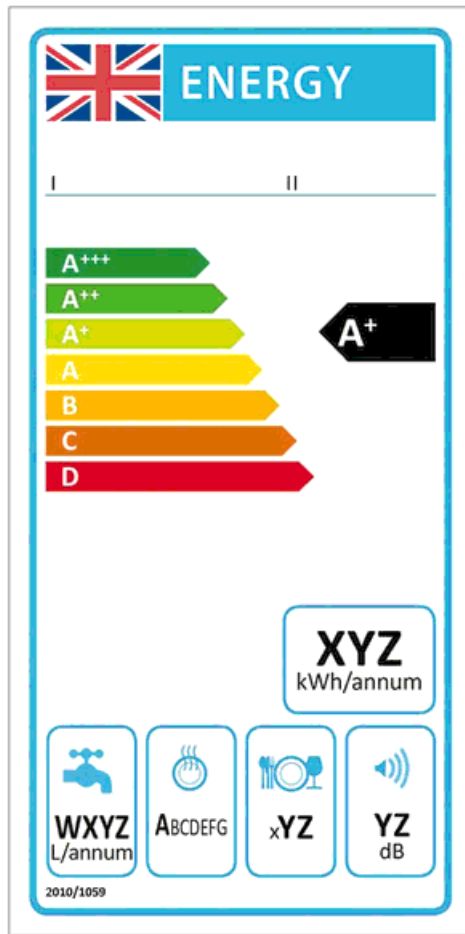

I
II
III
IV
V
VI
VII
VIII

(3) In paragraph 2 (label design)—

(a) for the label image, substitute the following image—

Status: This is the original version (as it was originally made). This item of legislation is currently only available in its original format.

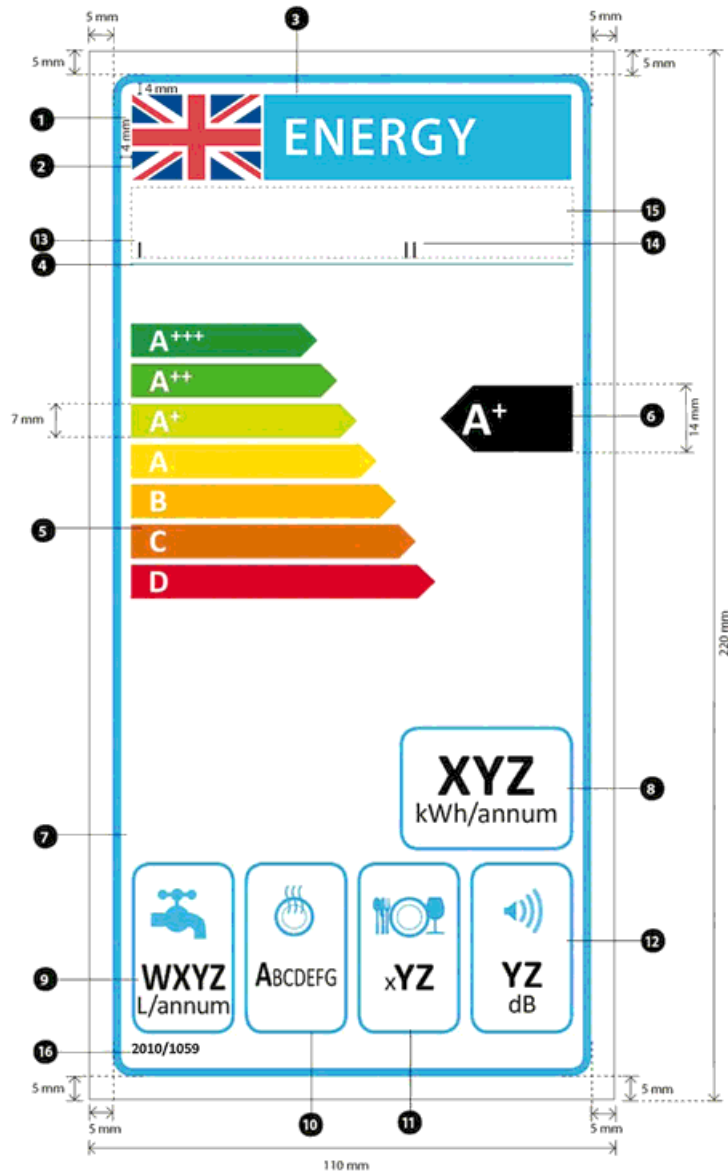

- (b) in subparagraph (d)—
 - (i) for point 2, substitute—
 - “UK flag colours—
 - the blue background: 100,72,00,18.5;
 - the red crosses: 00,100,81,4
 - the remaining part: 100% white;”;
 - (ii) in point 3, for “EU logo” substitute “UK flag”;
 - (iii) omit point 7.

3.—(1) In, Commission Delegated Regulation (EU) No 1060/2010 of 28 September 2010 supplementing [Directive 2010/30/EU](#) of the European Parliament and of the Council with regard to energy labelling of household refrigerating appliances, Annex 2 (label) is amended as follows.

Status: This is the original version (as it was originally made). This item of legislation is currently only available in its original format.

(2) In paragraph 1 (label for household refrigerating appliances classified in energy efficiency classes A+++ to C), for the label image substitute the following image—

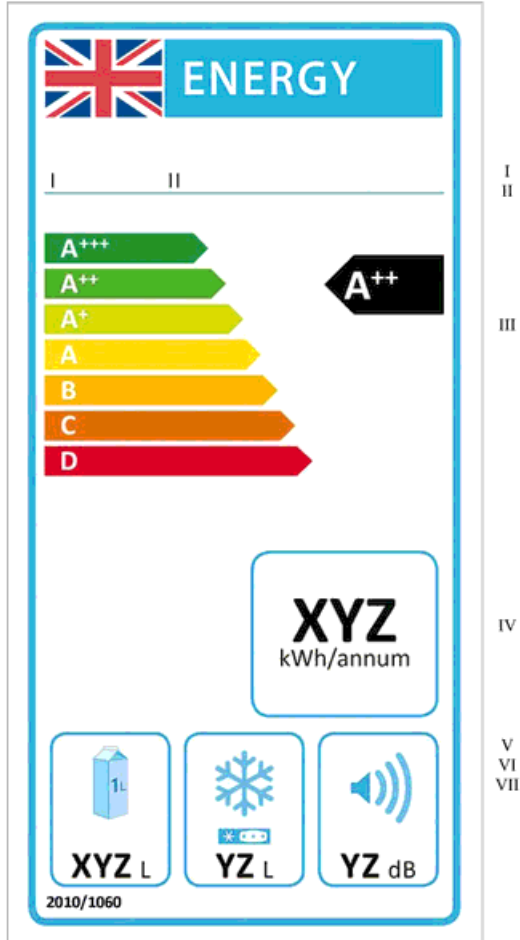

(3) In paragraph 2 (label for household refrigerating appliances classified in energy efficiency classes D to G), for the label image substitute the following image—

Status: This is the original version (as it was originally made). This item of legislation is currently only available in its original format.

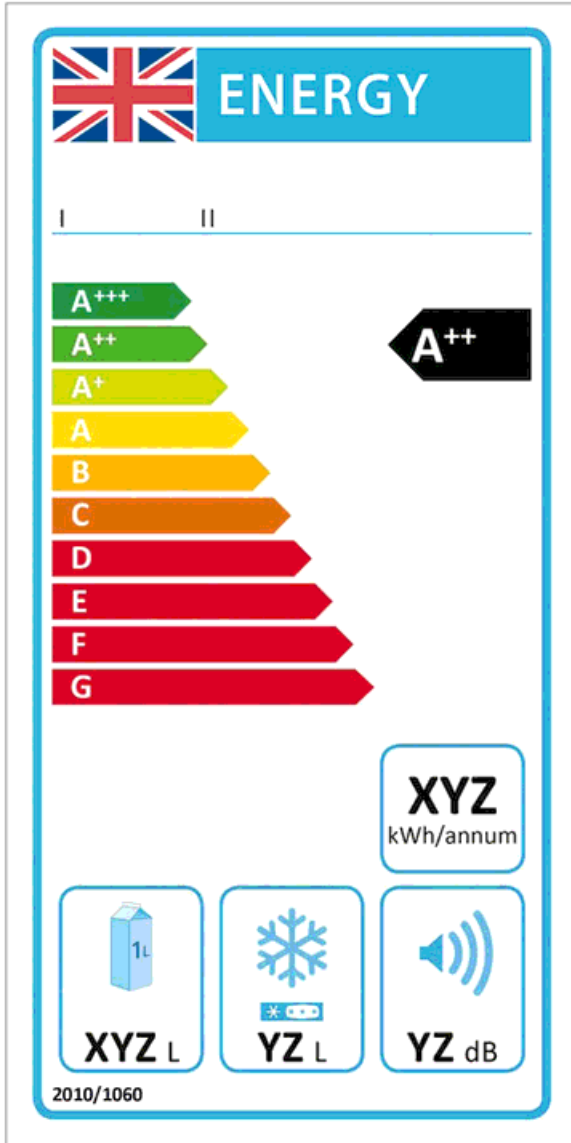

(4) In paragraph 3—

(a) for the label image in subparagraph (1), substitute the following image—

Status: This is the original version (as it was originally made). This item of legislation is currently only available in its original format.

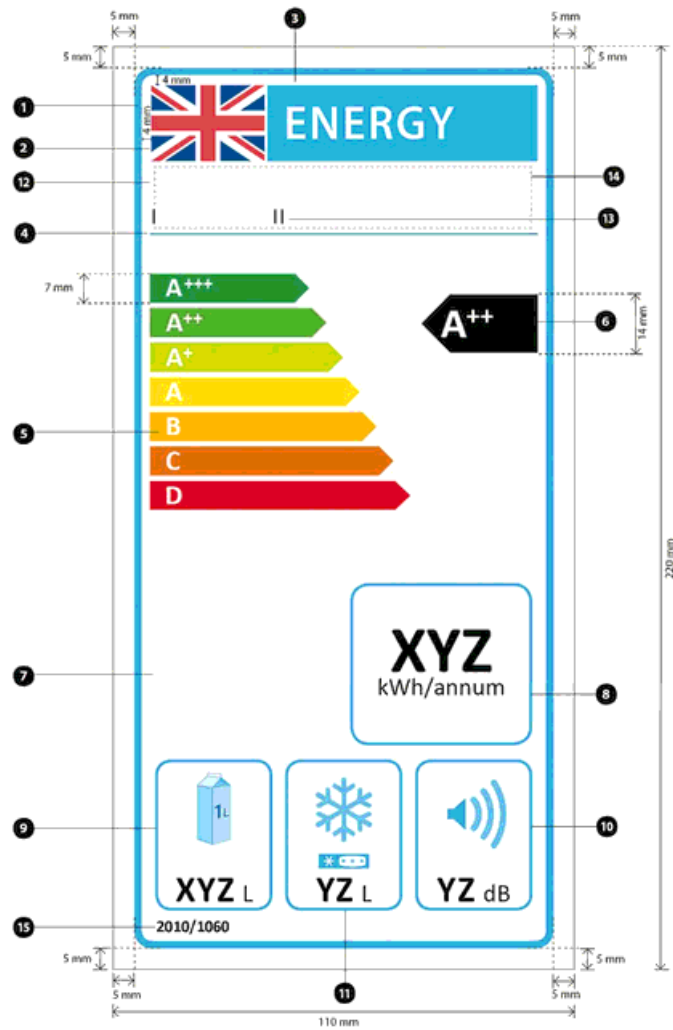

- (b) in subparagraph (1)(d)—
- (i) for point 2, substitute—
 - “UK flag: colours—
 - the blue background: 100,72,00,18.5;
 - the red crosses: 00,100,81,4
 - the remaining part: 100% white;”;
 - (ii) in point 3, for “EU logo” substitute “UK flag”;
 - (iii) omit point 7;
- (c) for the label image in subparagraph (2), substitute the following image—

Status: This is the original version (as it was originally made). This item of legislation is currently only available in its original format.

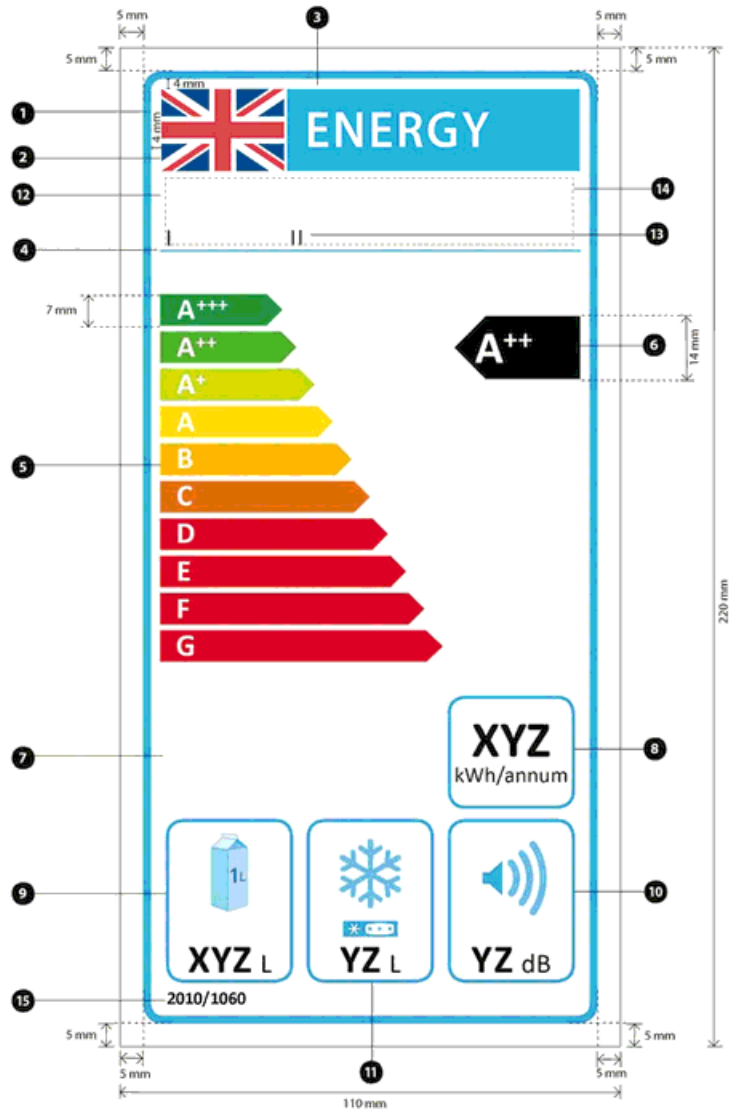

(d) for the label image in subparagraph (3), substitute the following image—

Status: This is the original version (as it was originally made). This item of legislation is currently only available in its original format.

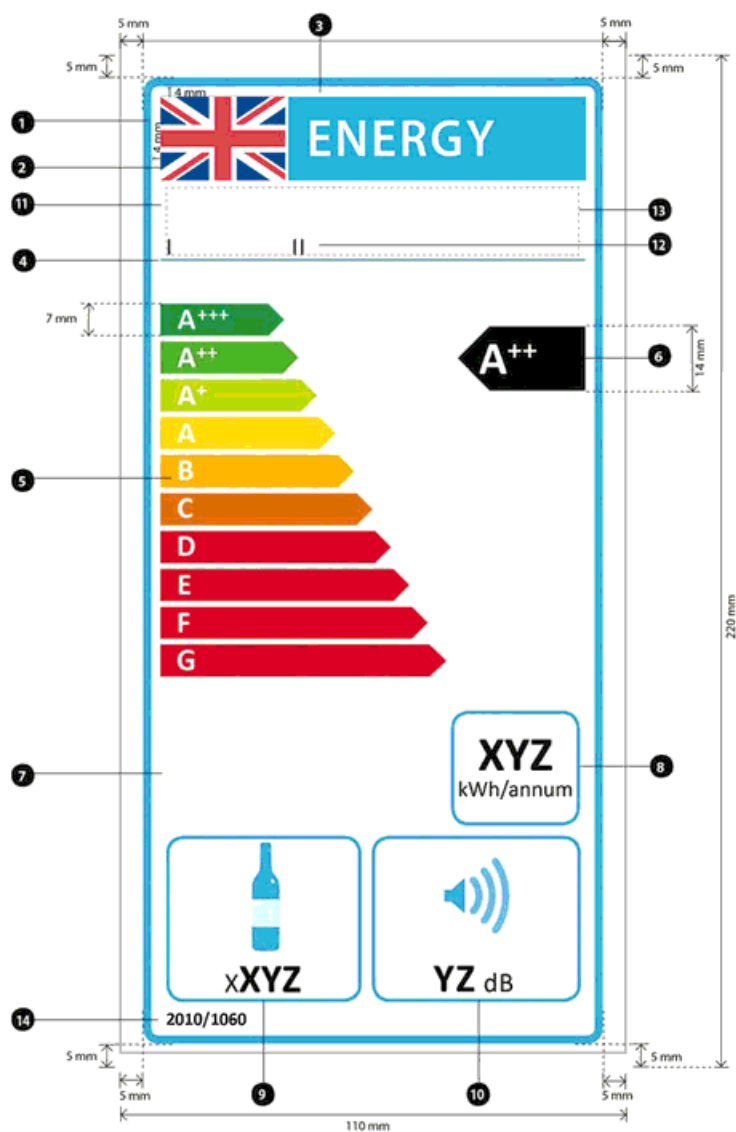

- (e) in subparagraph (3)(d)—
 - (i) for point 2, substitute—
 - “UK flag: colours—
 - the blue background: 100,72,00,18.5;
 - the red crosses: 00,100,81,4
 - the remaining part: 100% white;”;
 - (ii) in point 3, for “EU logo” substitute “UK flag”;
 - (iii) omit point 7.

4.—(1) In Commission Delegated Regulation (EU) No 1061/2010 of 28 September 2010 supplementing [Directive 2010/30/EU](#) of the European Parliament and of the Council with regard to energy labelling of household washing machines, Annex 1 (label) is amended as follows.

(2) In paragraph 1 (label), for the label image, substitute the following image—

Status: This is the original version (as it was originally made). This item of legislation is currently only available in its original format.

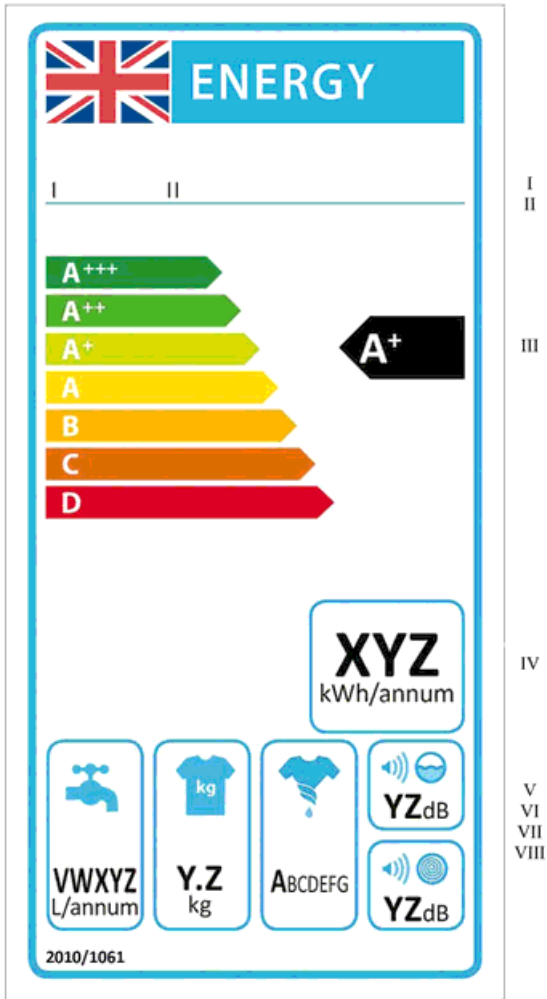

- (3) In paragraph 2 (label design)—
 - (a) for the label image, substitute the following image—

Status: This is the original version (as it was originally made). This item of legislation is currently only available in its original format.

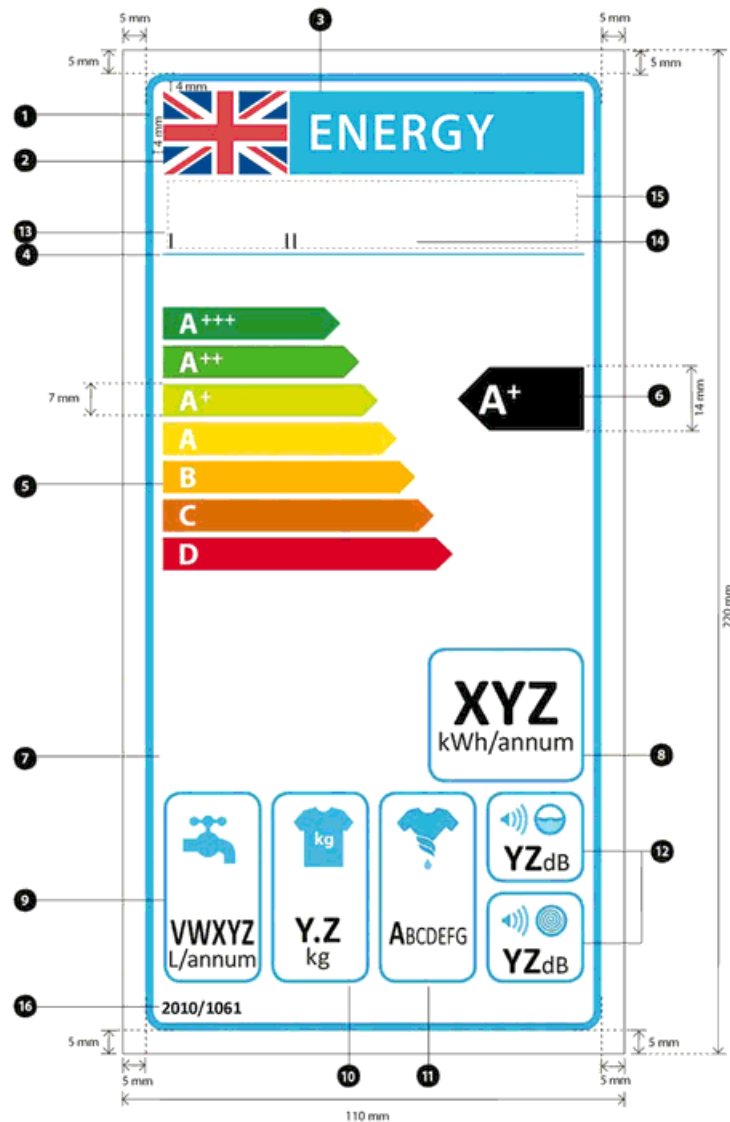

(b) in subparagraph (d)—

(i) for point 2, substitute—

“UK flag: colours—

the blue background: 100,72,00,18.5;

the red crosses: 00,100,81,4

the remaining part: 100% white;”;

(ii) in point 3, for “EU logo” substitute “UK flag”;

(iii) omit point 7.

5.—(1) In Commission Delegated Regulation (EU) No 1062/2010 of 28 September 2010 supplementing [Directive 2010/30/EU](#) of the European Parliament and of the Council with regard to energy labelling of televisions, Annex 5 (label) is amended as follows.

(2) In paragraph 4 (label 4), for the label image, substitute the following image—

Status: This is the original version (as it was originally made). This item of legislation is currently only available in its original format.

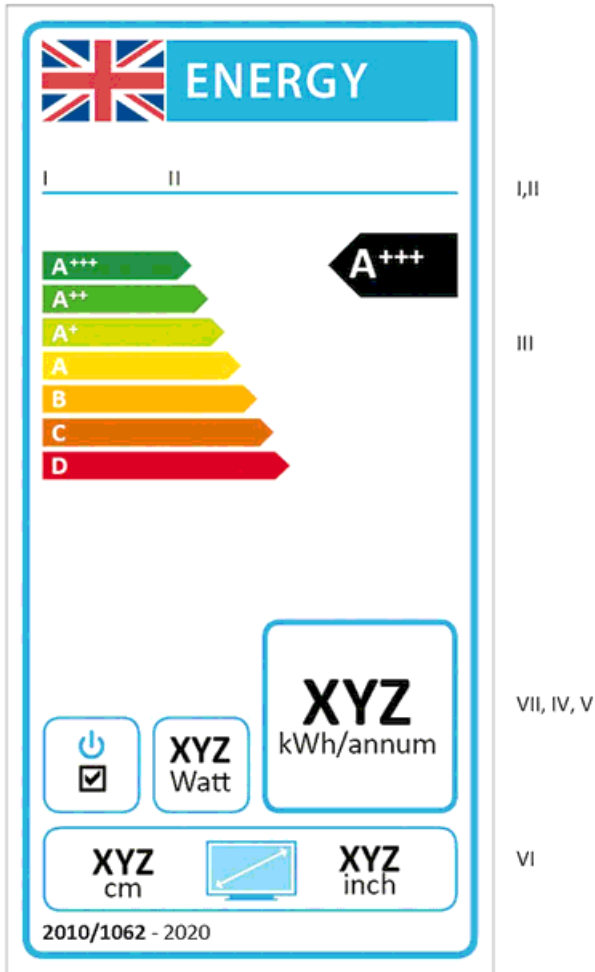

(3) In paragraph 5—

(a) for the label image, substitute the following image—

Status: This is the original version (as it was originally made). This item of legislation is currently only available in its original format.

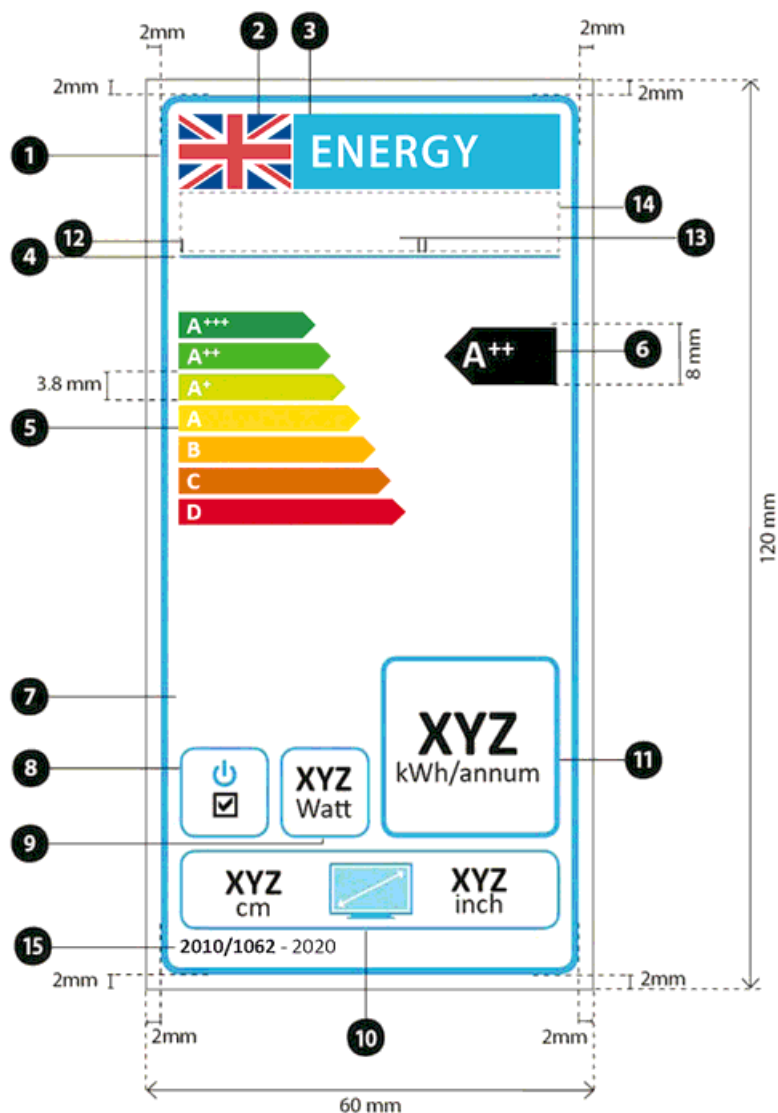

(b) in subparagraph (d)—

(i) for point 2, substitute—

“UK flag: colours—

the blue background: 100,72,00,18.5;

the red crosses: 00,100,81,4

the remaining part: 100% white;”;

(ii) in point 3, for “EU logo” substitute “UK flag”;

(iii) omit point 7.

6.—(1) In Commission Delegated Regulation (EU) No 626/2011 of 4 May 2011 supplementing [Directive 2010/30/EU](#) of the European Parliament and of the Council with regard to energy labelling of air conditioners, Annex 3 (the label) is amended as follows.

(2) In paragraph 1.4 (reversible air conditioners classified in energy efficiency classes A+++ to D), for the label image, substitute the following image—

Status: This is the original version (as it was originally made). This item of legislation is currently only available in its original format.

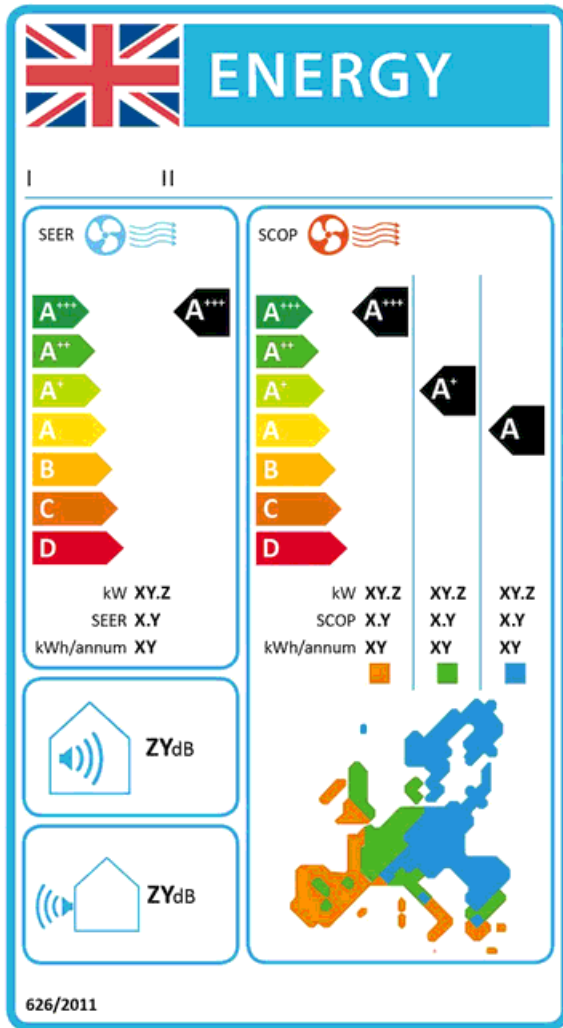

I
II
III
IV
V
VI
VII
VIII
IX
X
XI

(3) In paragraph 1.5 (label design), for the label image, substitute the following image—

Status: This is the original version (as it was originally made). This item of legislation is currently only available in its original format.

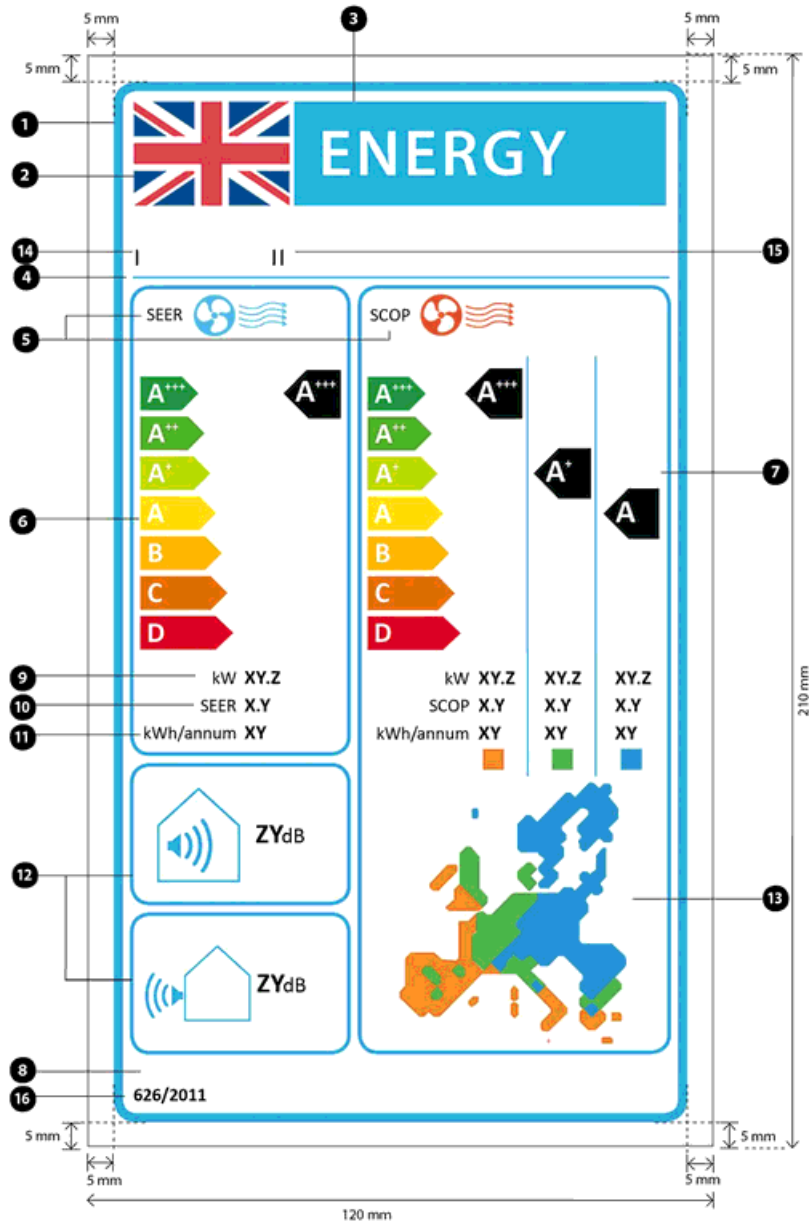

(4) In paragraph 2.4 (cooling-only air conditioners classified in energy efficiency classes A+++ to D), for the label image, substitute the following image—

Status: This is the original version (as it was originally made). This item of legislation is currently only available in its original format.

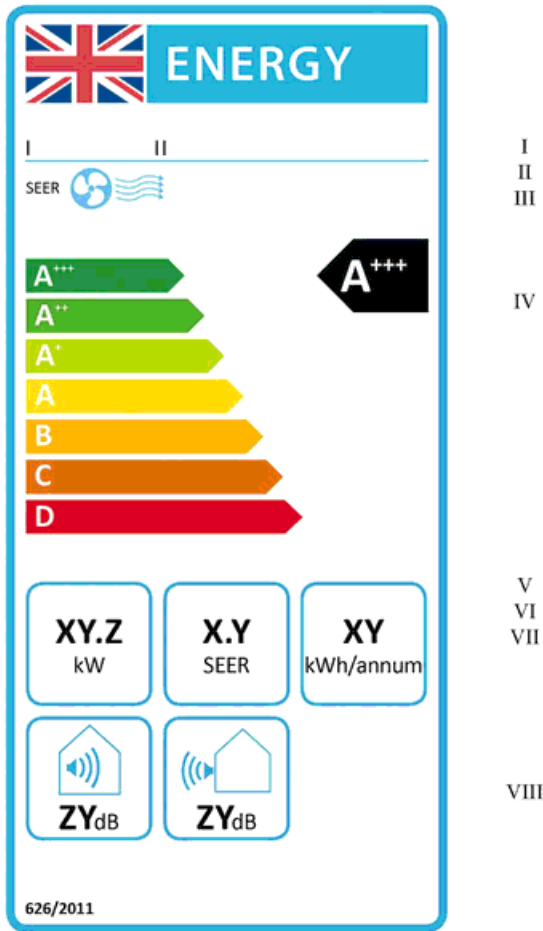

(5) In paragraph 2.5 (label design), for the label image, substitute the following image—

Status: This is the original version (as it was originally made). This item of legislation is currently only available in its original format.

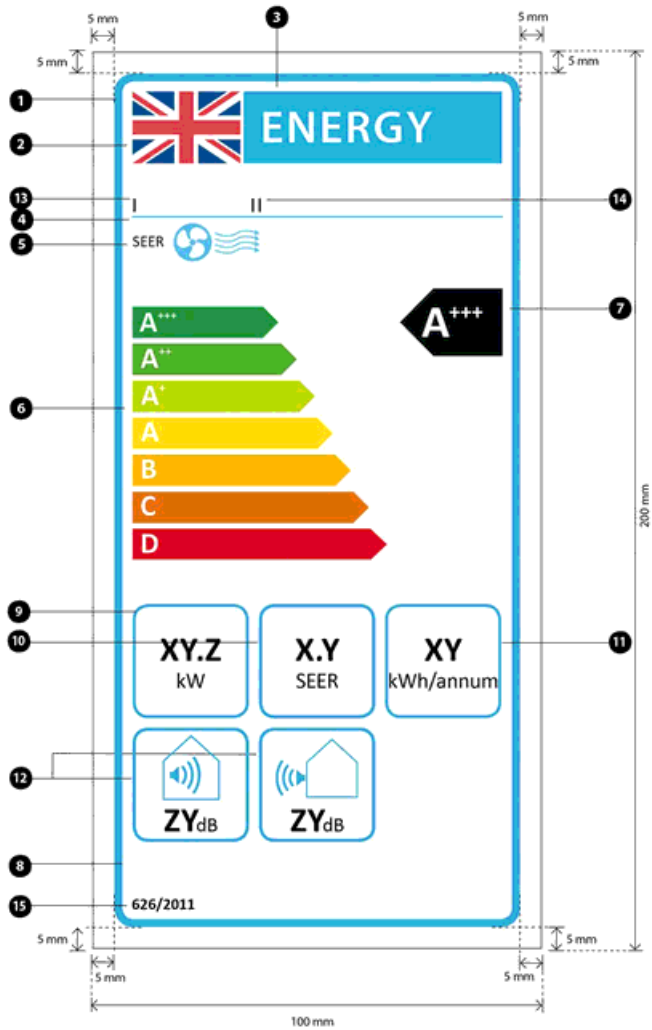

(6) In paragraph 3.4 (heating-only air conditioners classified in energy efficiency classes A+++ to D), for the label image, substitute the following image—

Status: This is the original version (as it was originally made). This item of legislation is currently only available in its original format.

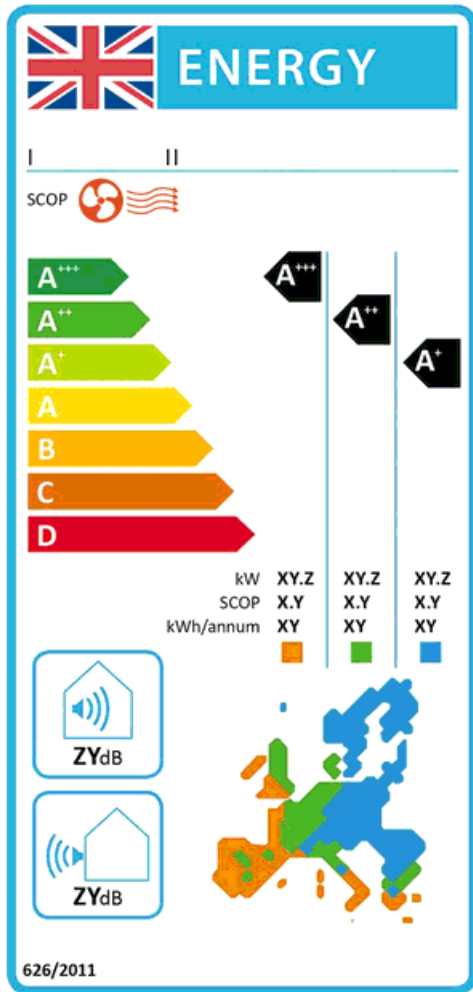

I
II
III

IV

V
VI
VII

VIII
IX

(7) In paragraph 3.5 (label design), for the label image, substitute the following image—

Status: This is the original version (as it was originally made). This item of legislation is currently only available in its original format.

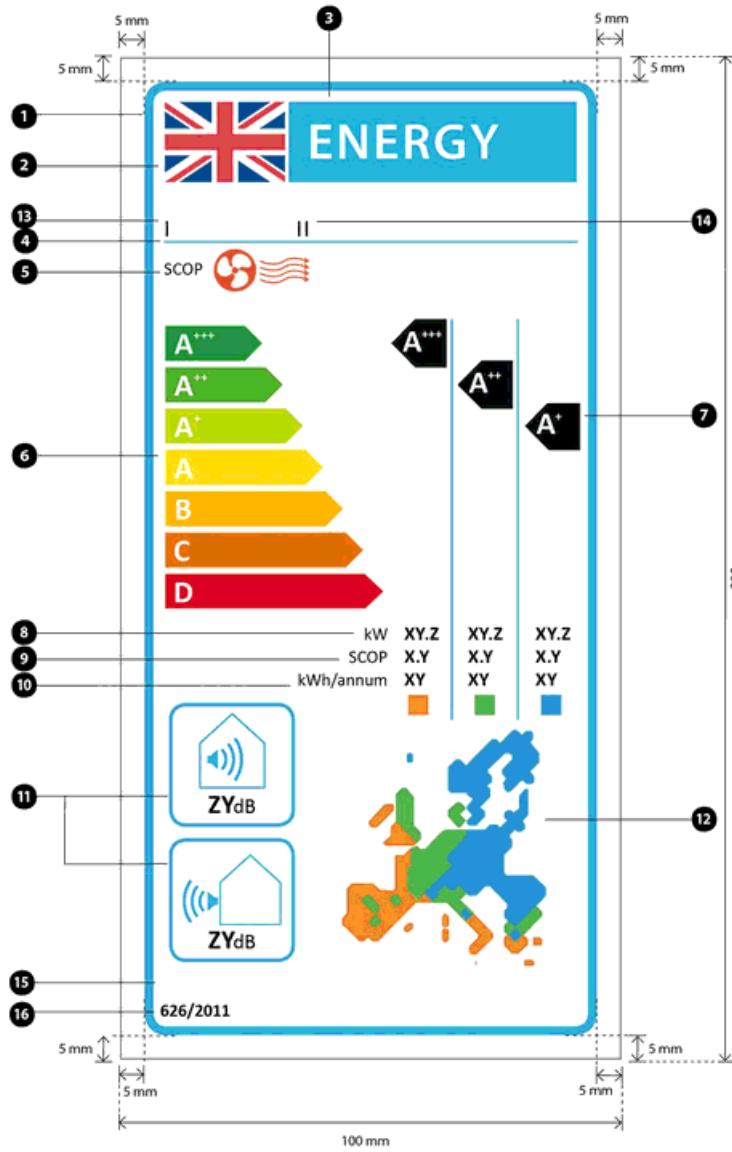

(8) In paragraph 4.1 (reversible double duct air conditioners classified in energy efficiency classes A+++ to D), for the label image, substitute the following image—

Status: This is the original version (as it was originally made). This item of legislation is currently only available in its original format.

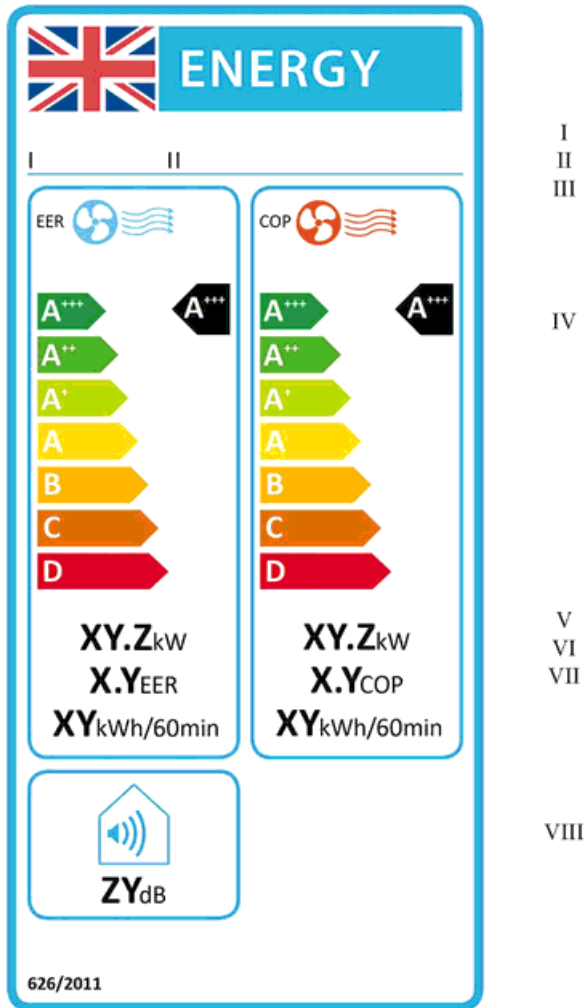

(9) In paragraph 4.2 (label design), for the label image, substitute the following image—

Status: This is the original version (as it was originally made). This item of legislation is currently only available in its original format.

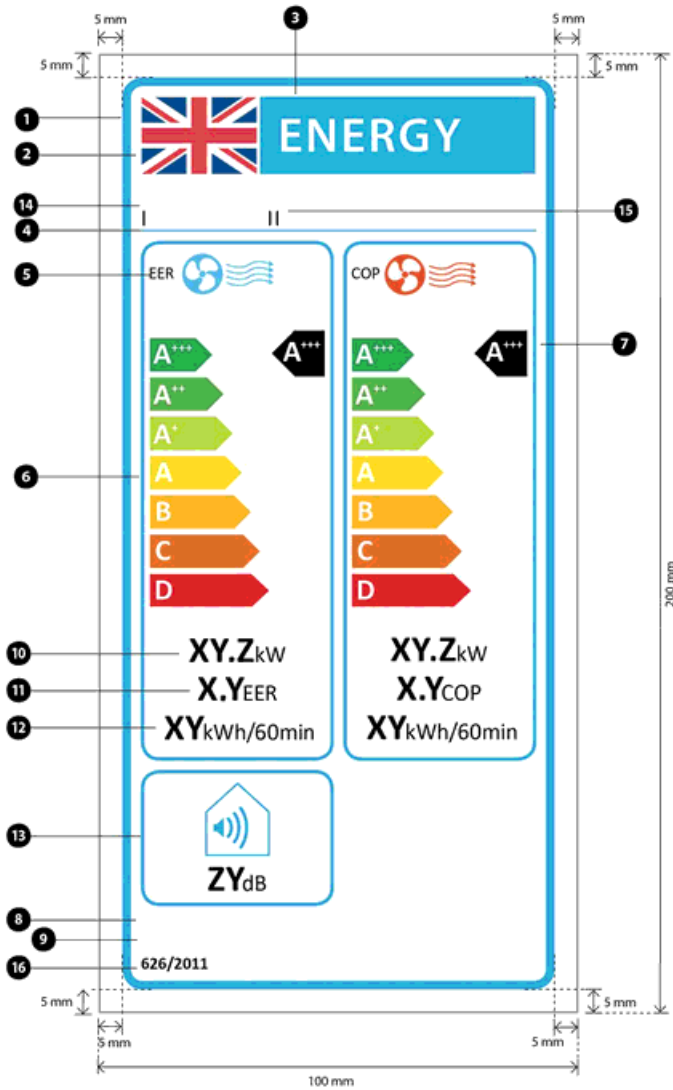

(10) In paragraph 4.3 (cooling-only double duct air conditioners classified in energy efficiency classes A+++ to D), for the label image, substitute the following image—

Status: This is the original version (as it was originally made). This item of legislation is currently only available in its original format.

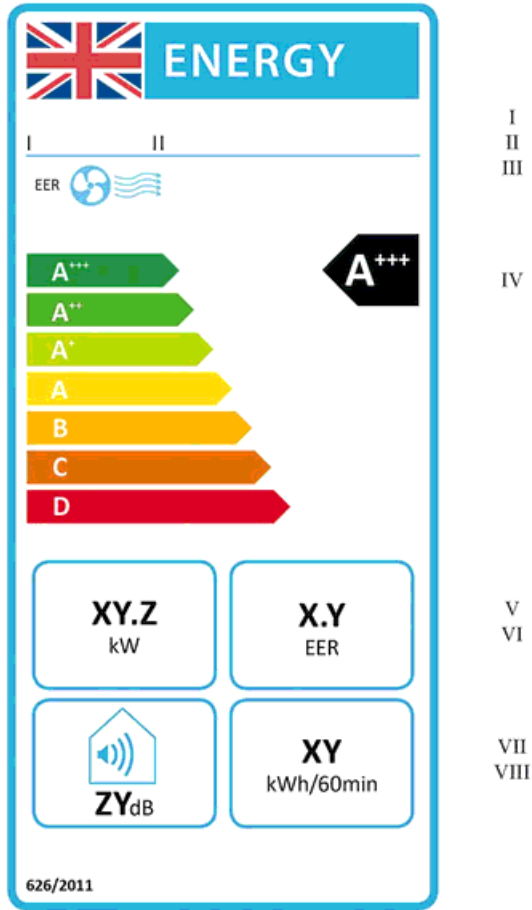

(11) In paragraph 4.4 (label design), for the label image, substitute the following image—

Status: This is the original version (as it was originally made). This item of legislation is currently only available in its original format.

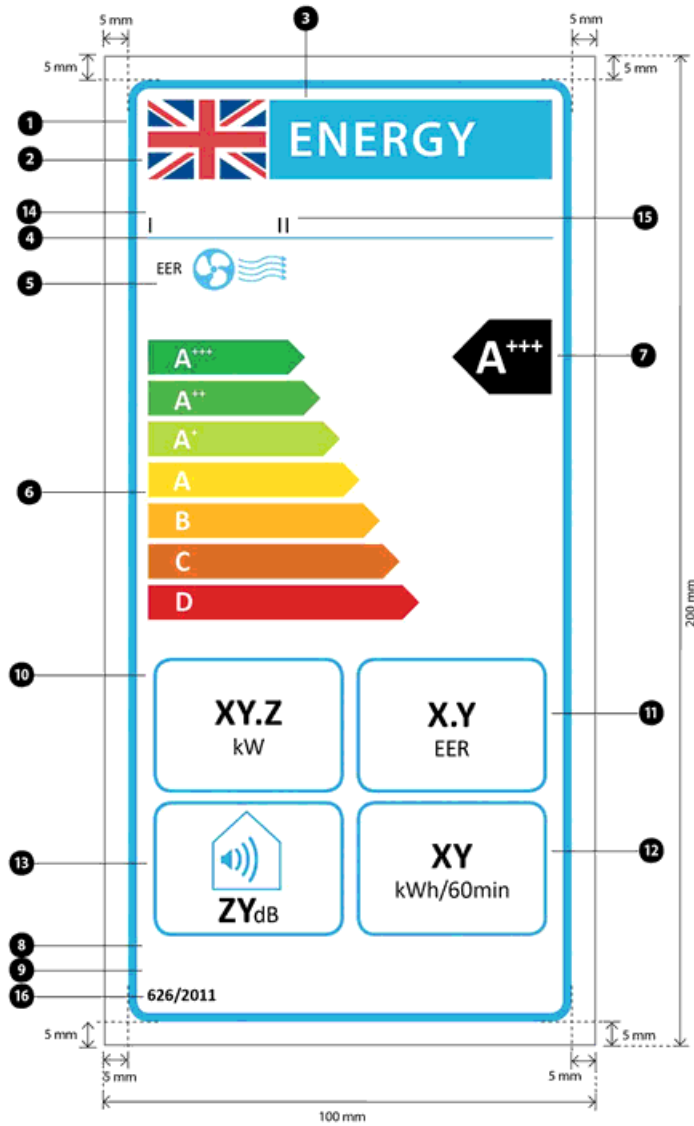

(12) In paragraph 4.5 (heating-only double duct air conditioners classified in energy efficiency classes A+++ to D), for the label image, substitute the following image—

Status: This is the original version (as it was originally made). This item of legislation is currently only available in its original format.

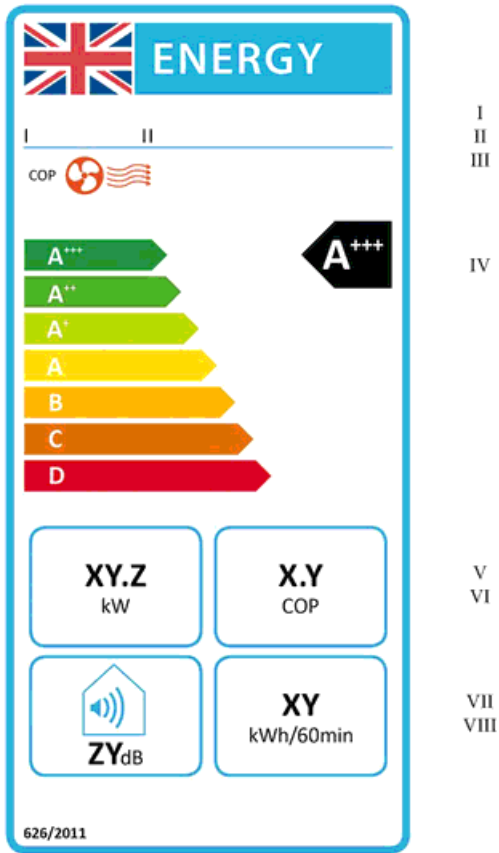

(13) In paragraph 4.6 (label design), for the label image, substitute the following image—

Status: This is the original version (as it was originally made). This item of legislation is currently only available in its original format.

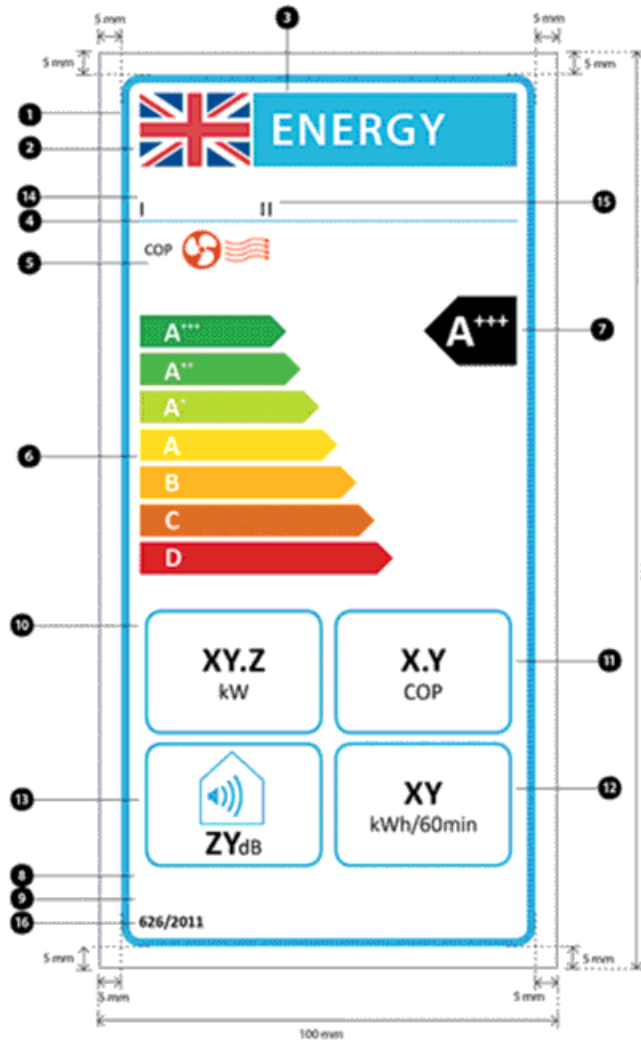

(14) In paragraph 5.1 (reversible single duct air conditioners classified in energy efficiency classes A+++ to D), for the label image, substitute the following image—

Status: This is the original version (as it was originally made). This item of legislation is currently only available in its original format.

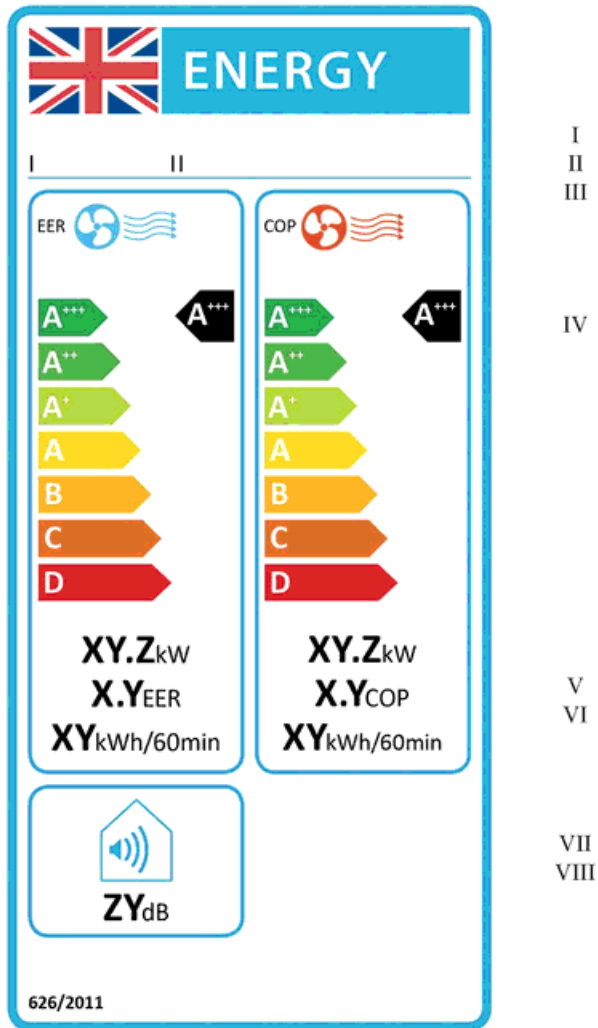

(15) In paragraph 5.2 (label design), for the label image, substitute the following image—

Status: This is the original version (as it was originally made). This item of legislation is currently only available in its original format.

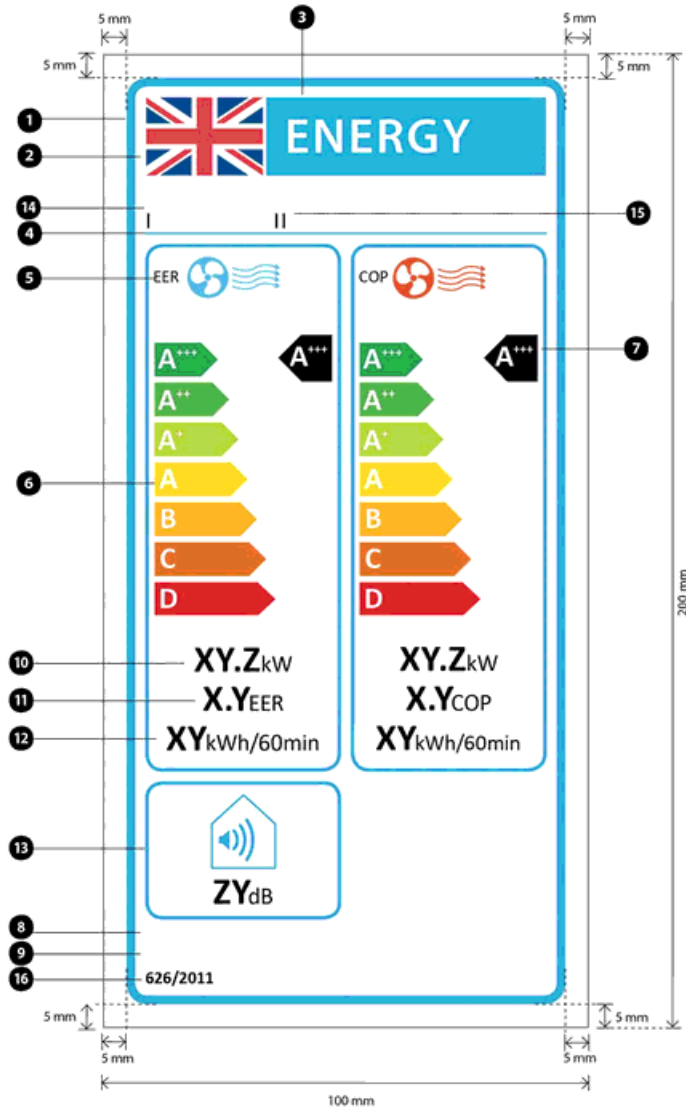

(16) In paragraph 5.3 (cooling-only single duct air conditioners classified in energy efficiency classes A+++ to D), for the label image, substitute the following image—

Status: This is the original version (as it was originally made). This item of legislation is currently only available in its original format.

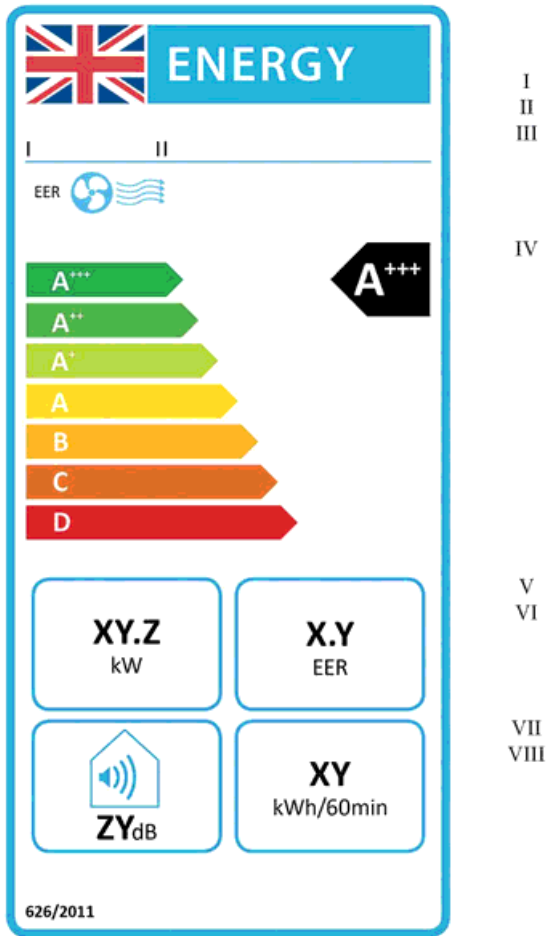

(17) In paragraph 5.4 (label design), for the label image, substitute the following image—

Status: This is the original version (as it was originally made). This item of legislation is currently only available in its original format.

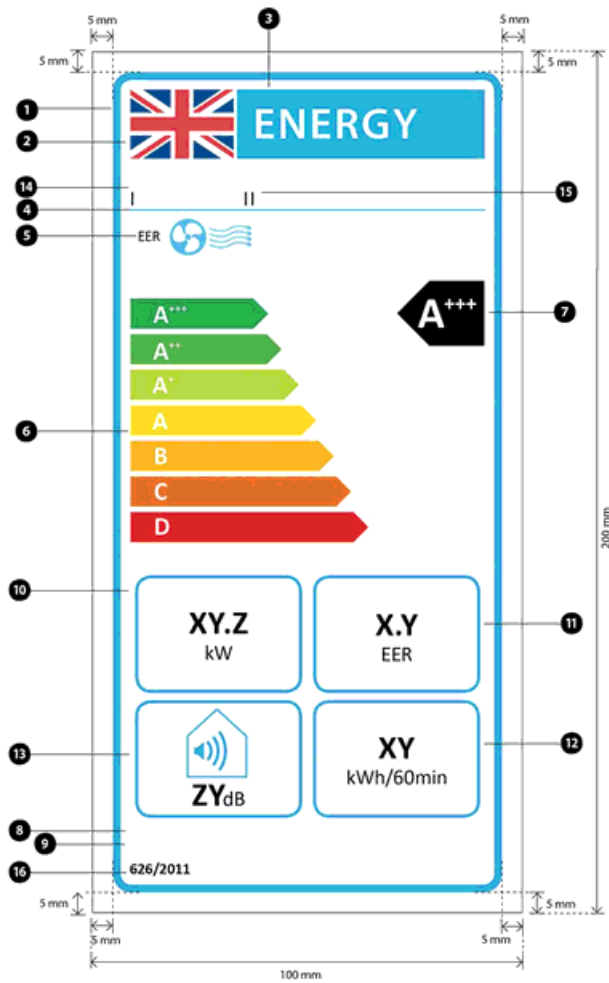

(18) In paragraph 5.5 (heating-only single duct air conditioners classified in energy efficiency classes A+++ to D), for the label image, substitute the following image—

Status: This is the original version (as it was originally made). This item of legislation is currently only available in its original format.

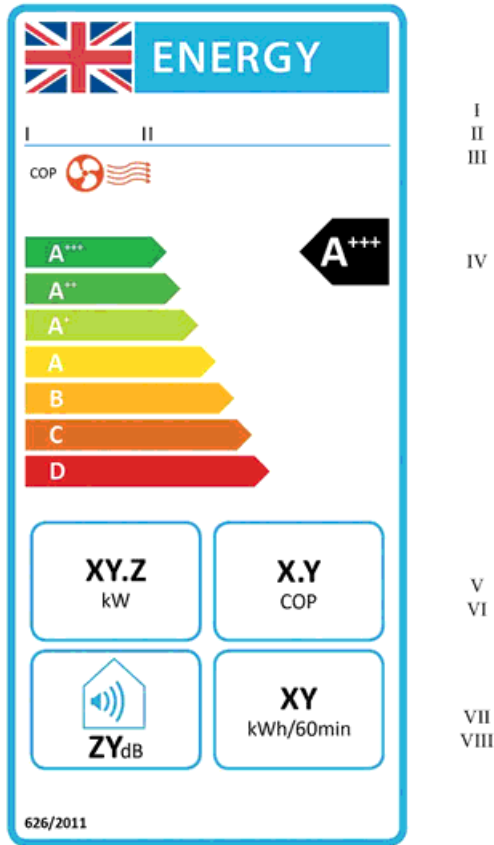

(19) In paragraph 5.6 (label design), for the label image, substitute the following image—

Status: This is the original version (as it was originally made). This item of legislation is currently only available in its original format.

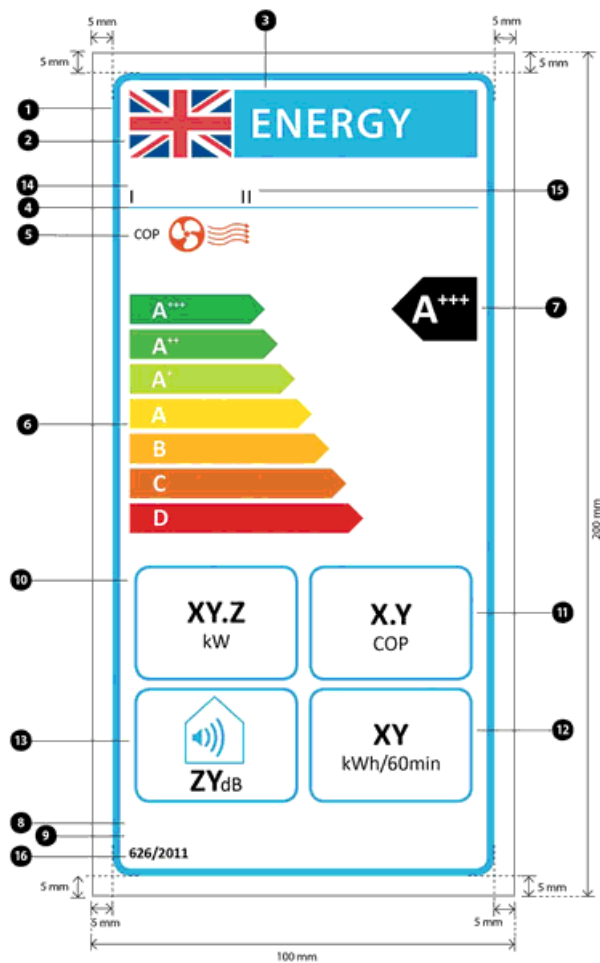

(20) In each of subparagraphs 1.5(iv), 2.5(iv), 3.5(iv), 4.2(iv), 4.4(iv), 4.6(iv), 5.2(iv), 5.4(iv) and 5.6(iv)—

(a) for point 2, substitute—

“UK flag: colours—

the blue background: 100,72,00,18.5;

the red crosses: 00,100,81,4

the remaining part: 100% white;”;

(b) in point 3, for “EU logo” substitute “UK flag”.

7.—(1) In Commission Delegated Regulation (EU) No 392/2012 of 1 March 2012 supplementing [Directive 2010/30/EU](#) of the European Parliament and of the Council with regard to energy labelling of household tumble driers, Annex 1 (label) is amended as follows.

(2) In paragraph 1 (label for air-vented household tumble dryer), for the label image, substitute the following image—

Status: This is the original version (as it was originally made). This item of legislation is currently only available in its original format.

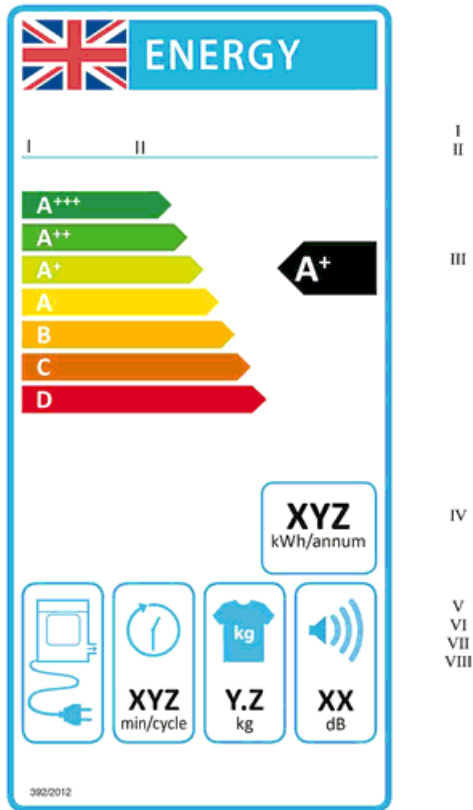

(3) In paragraph 2 (label for condenser household tumble dryer), for the label image, substitute the following image—

Status: This is the original version (as it was originally made). This item of legislation is currently only available in its original format.

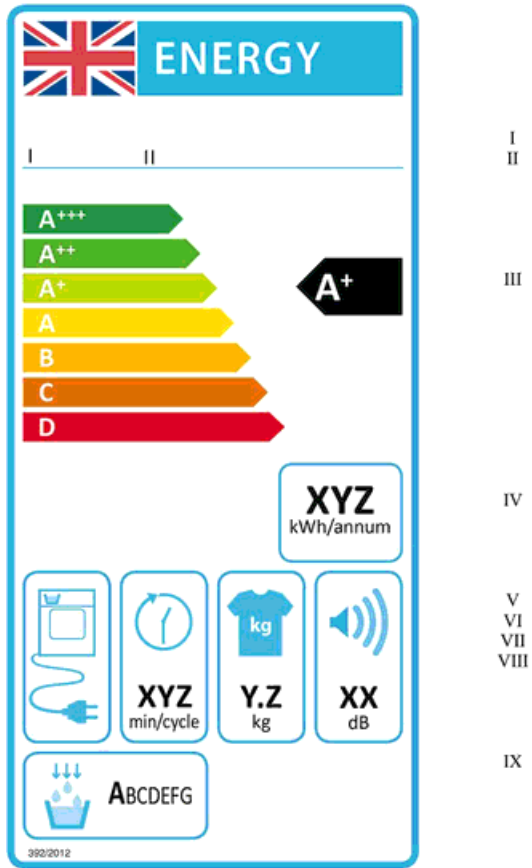

(4) In paragraph 3 (label for gas-fired household tumble dryer), for the label image, substitute the following image—

Status: This is the original version (as it was originally made). This item of legislation is currently only available in its original format.

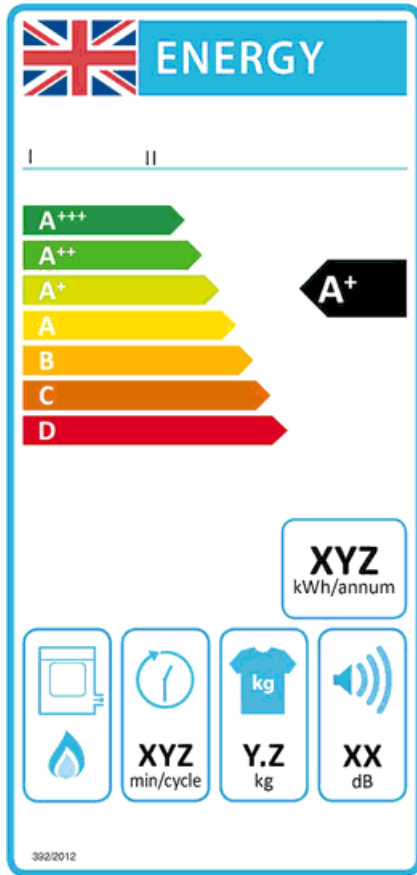

I
II

III

IV

V
VI
VII
VIII

(5) In paragraph 4 (label design)—

(a) in subparagraph 4.1, for the label image, substitute the following image—

Status: This is the original version (as it was originally made). This item of legislation is currently only available in its original format.

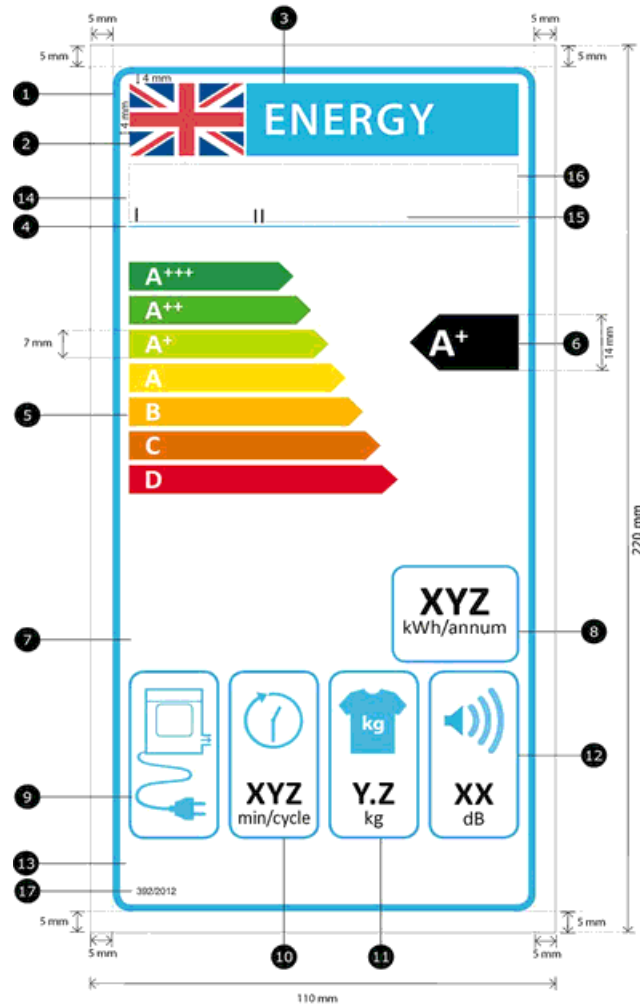

(b) in subparagraph 4.2, for the label image, substitute the following image--

Status: This is the original version (as it was originally made). This item of legislation is currently only available in its original format.

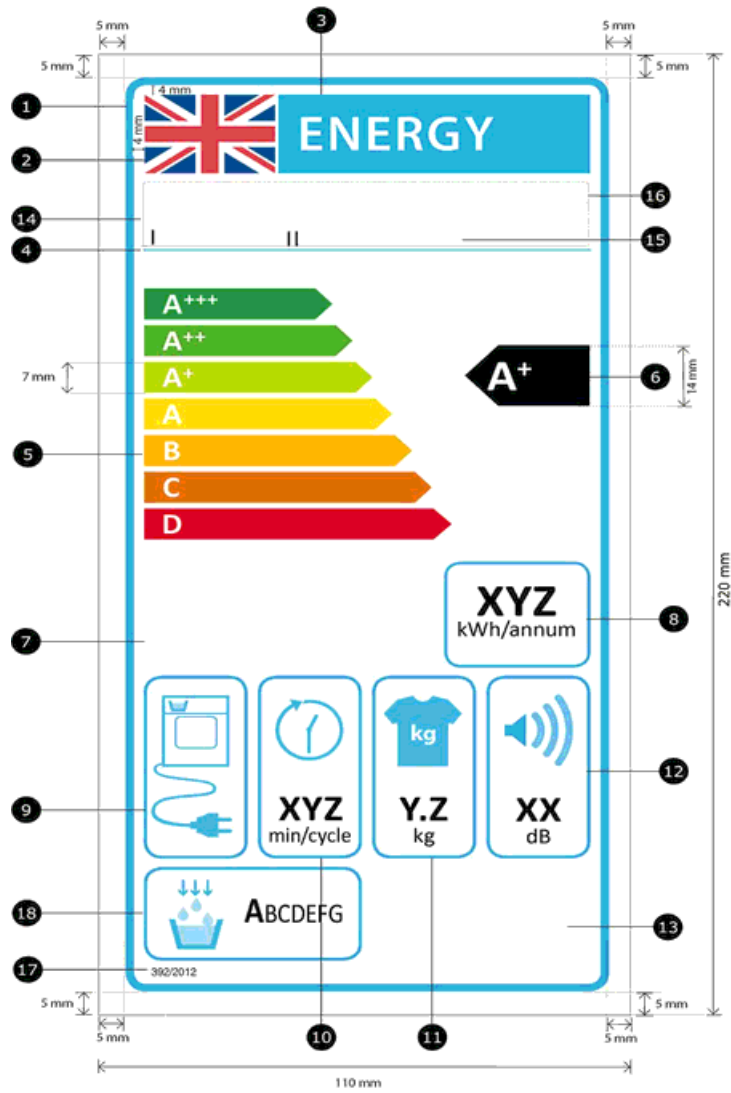

(c) in subparagraph 4.3 for the label image, substitute the following image—

Status: This is the original version (as it was originally made). This item of legislation is currently only available in its original format.

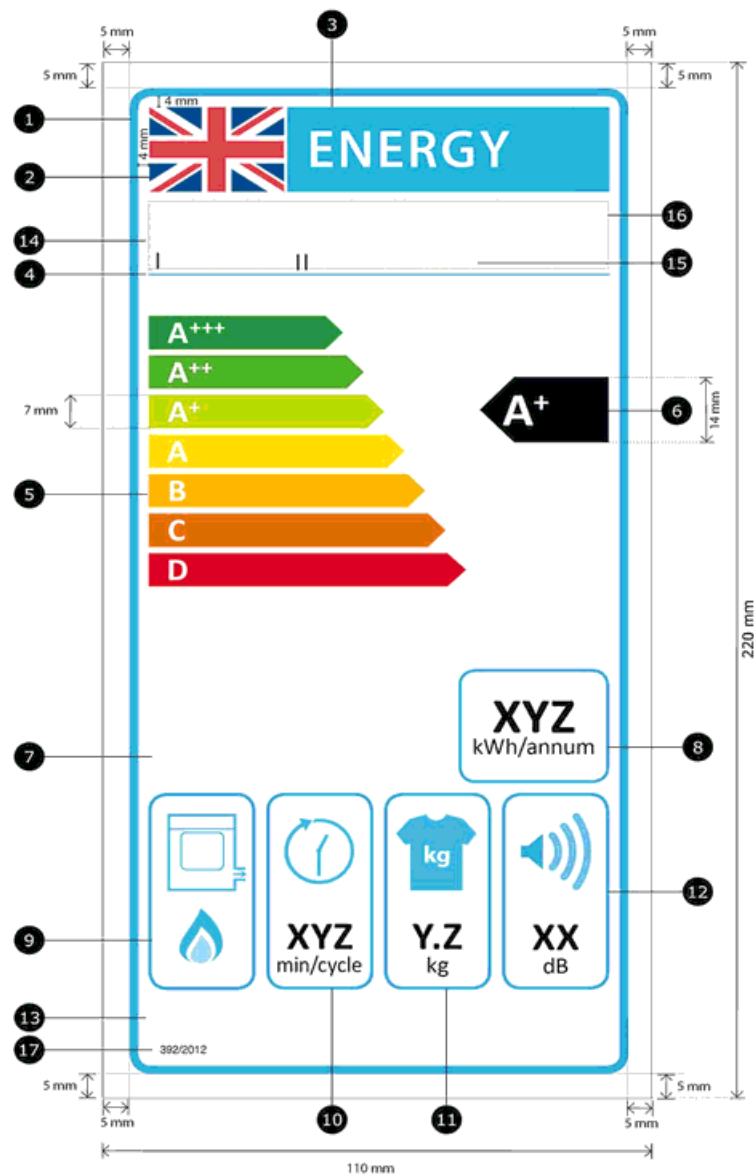

(d) in each of subparagraphs 4.1(d), 4.2(d) and 4.3(d)—

(i) for point 2, substitute—

“UK flag: colours—

the blue background: 100,72,00,18.5;

the red crosses: 00,100,81,4

the remaining part: 100% white;”;

(ii) in point 3, for “EU logo” substitute “UK flag”;

(iii) omit point 7.

8.—(1) In Commission Delegated Regulation (EU) No 811/2013 of 18 February 2013 supplementing [Directive 2010/30/EU](#) of the European Parliament and of the Council with regard to the energy labelling of space heaters, combination heaters, packages of space heater, temperature

Status: This is the original version (as it was originally made). This item of legislation is currently only available in its original format.

control and solar device and packages of combination heater, temperature control and solar device, Annex 3 (the labels) is amended as follows.

(2) In paragraph 1.2.1 (boiler space heaters in seasonal space heating energy efficiency classes A+++ to D), for the label image substitute the following image—

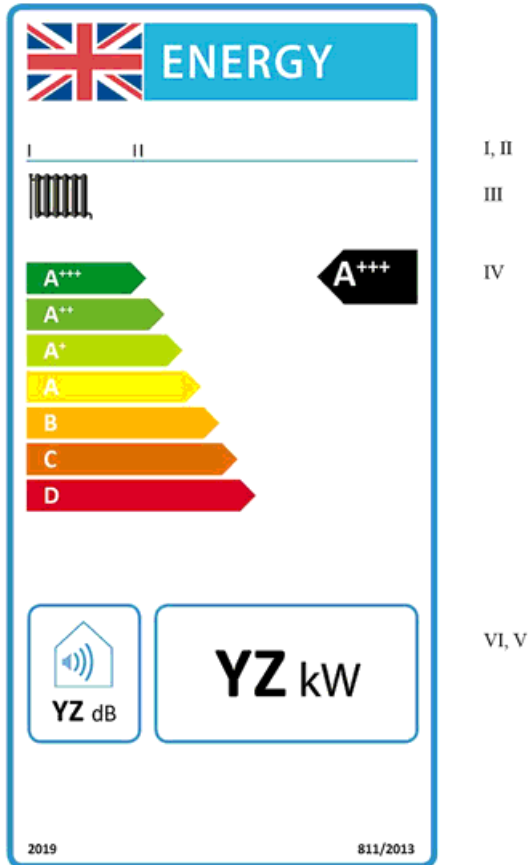

(3) In paragraph 1.2.2 (cogeneration space heaters in seasonal space heating energy efficiency classes A+++ to D), for the label image substitute the following image—

Status: This is the original version (as it was originally made). This item of legislation is currently only available in its original format.

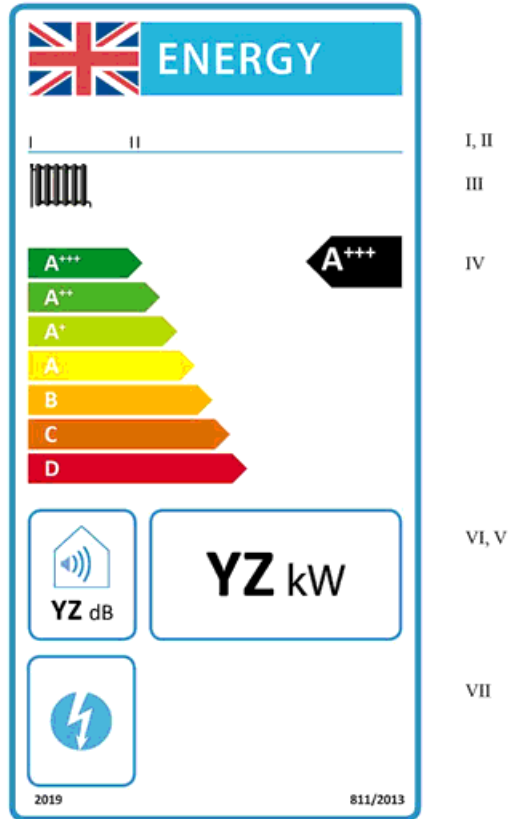

(4) In paragraph 1.2.3 (heat pump space heaters, except low-temperature heat pumps, in seasonal space heating energy efficiency classes A+++ to D), for the label image substitute the following image—

Status: This is the original version (as it was originally made). This item of legislation is currently only available in its original format.

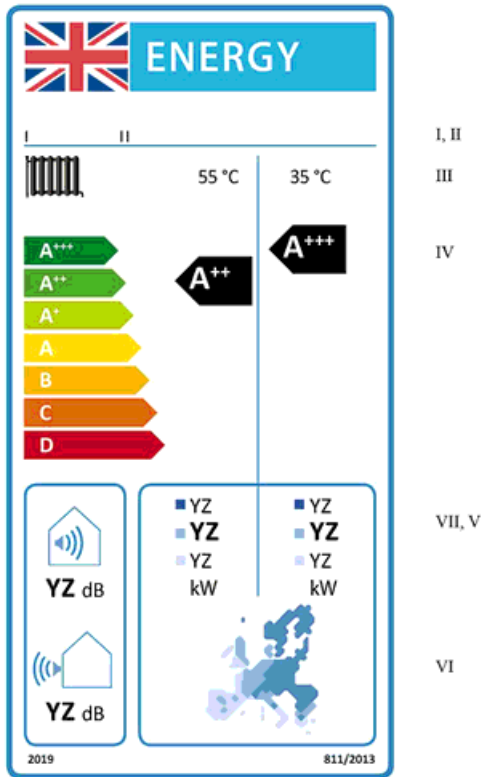

(5) In paragraph 1.2.4 (low-temperature heat pumps in seasonal space heating energy efficiency classes A+++ to D), for the label image substitute the following image—

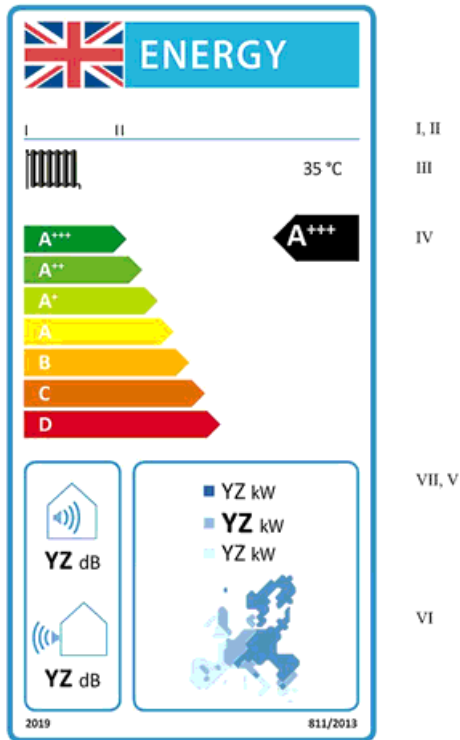

Status: This is the original version (as it was originally made). This item of legislation is currently only available in its original format.

(6) In paragraph 2.2.1 (boiler combination heaters in seasonal space heating energy efficiency classes A+++ to D and in water heating energy efficiency classes A+ to F), for the label image substitute the following image—

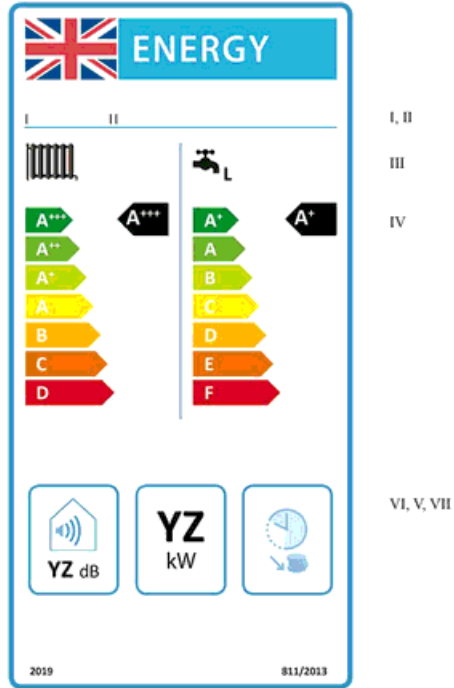

(7) In paragraph 2.2.2 (heat pump combination heaters in seasonal space heating energy efficiency classes A+++ to D and in water heating energy efficiency classes A+ to F), for the label image substitute the following image—

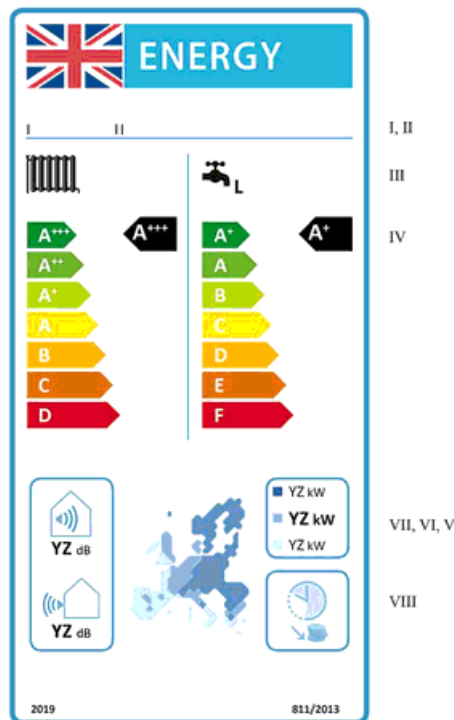

Status: This is the original version (as it was originally made). This item of legislation is currently only available in its original format.

(8) In paragraph 3 (packages of space heater, temperature control and solar device), for the label image substitute the following image—

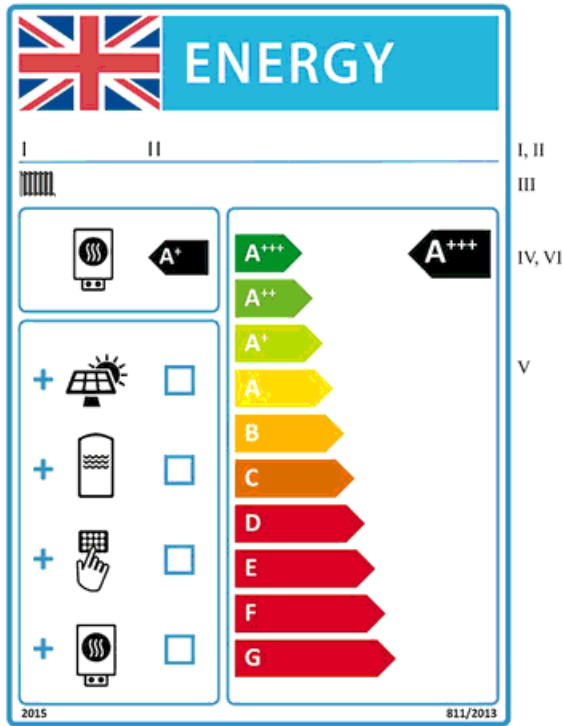

(9) In paragraph 4 (packages of combination heater, temperature control and solar device), for the label image substitute the following image—

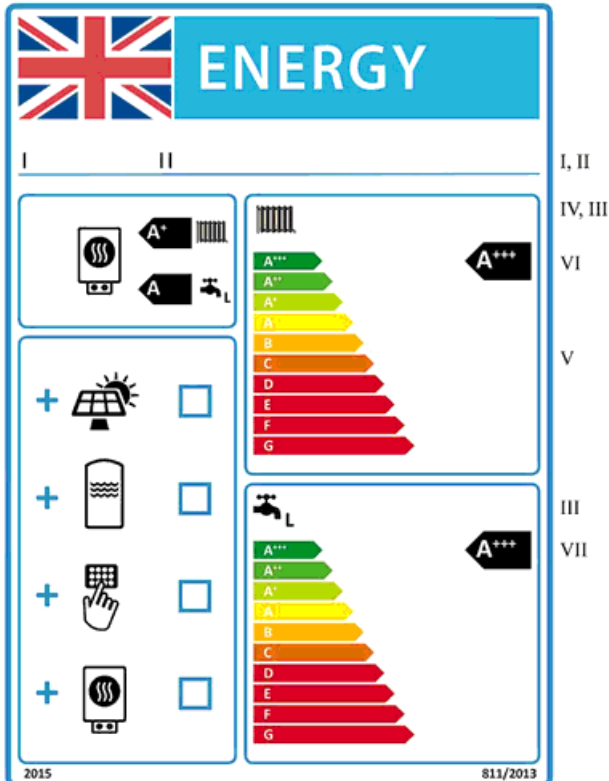

Status: This is the original version (as it was originally made). This item of legislation is currently only available in its original format.

(10) In paragraph 5 (label design for boiler space heaters), for the label image substitute the following image—

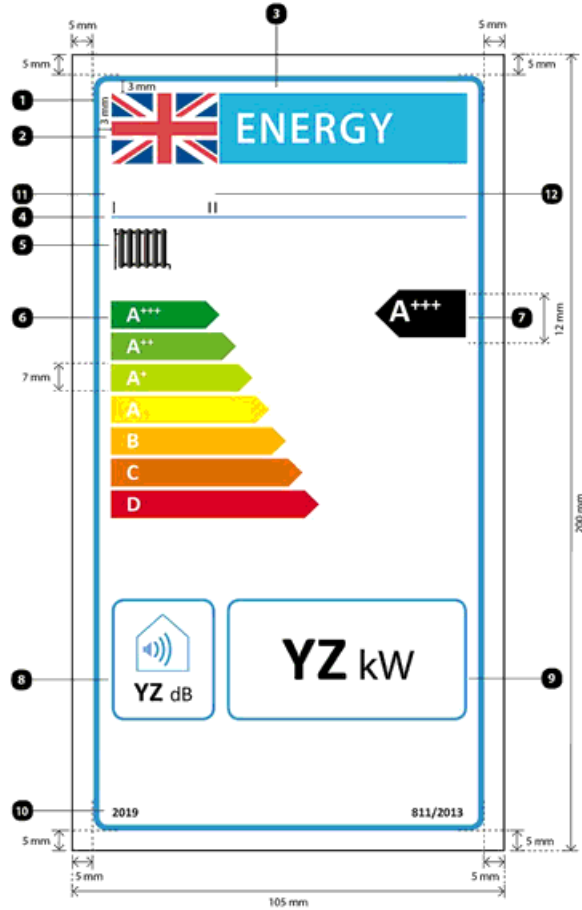

(11) In paragraph 6 (label design for cogeneration space heaters), for the label image substitute the following image—

Status: This is the original version (as it was originally made). This item of legislation is currently only available in its original format.

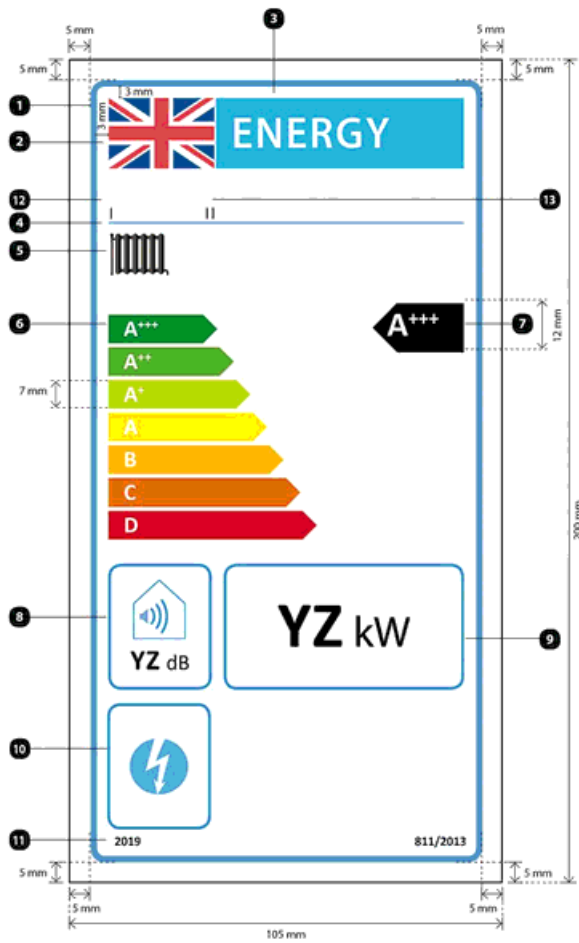

(12) In paragraph 7 (label design for heat pump space heaters), for the label image substitute the following image—

Status: This is the original version (as it was originally made). This item of legislation is currently only available in its original format.

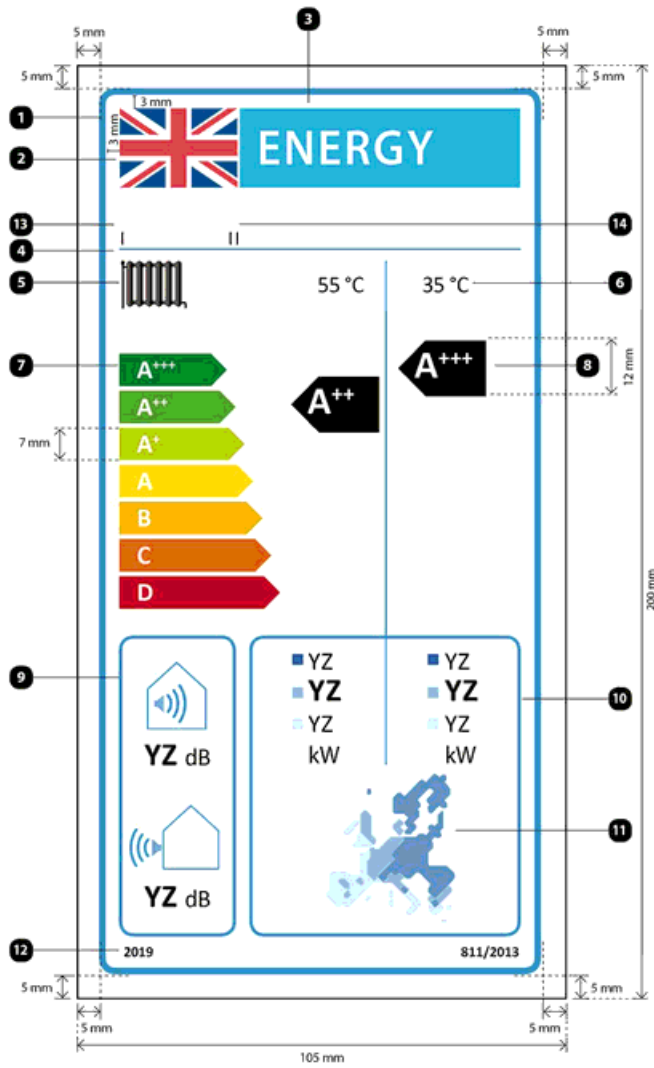

(13) In paragraph 8 (label design for low temperature heat pumps), for the label image substitute the following image—

Status: This is the original version (as it was originally made). This item of legislation is currently only available in its original format.

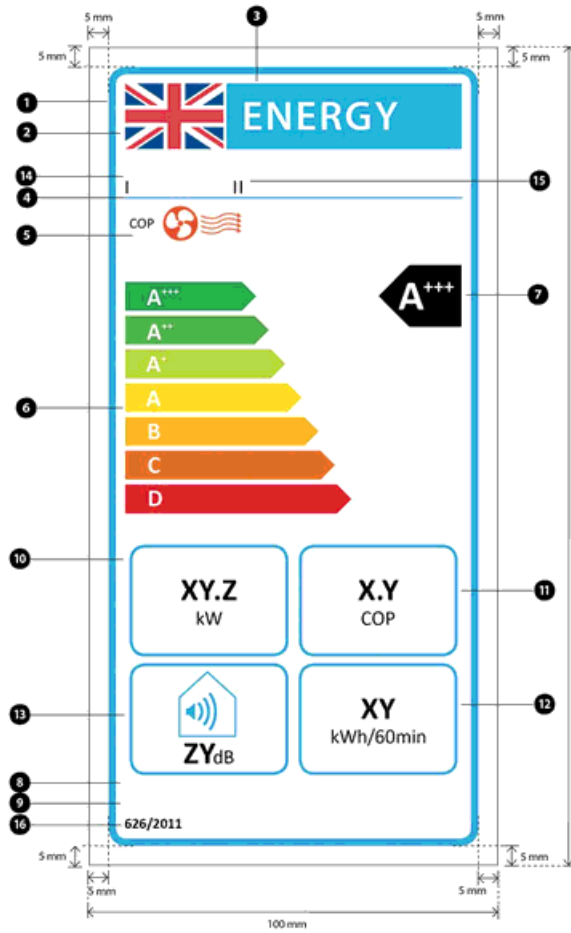

(14) In paragraph 9 (label design for boiler combination heaters), for the label image substitute the following image—

Status: This is the original version (as it was originally made). This item of legislation is currently only available in its original format.

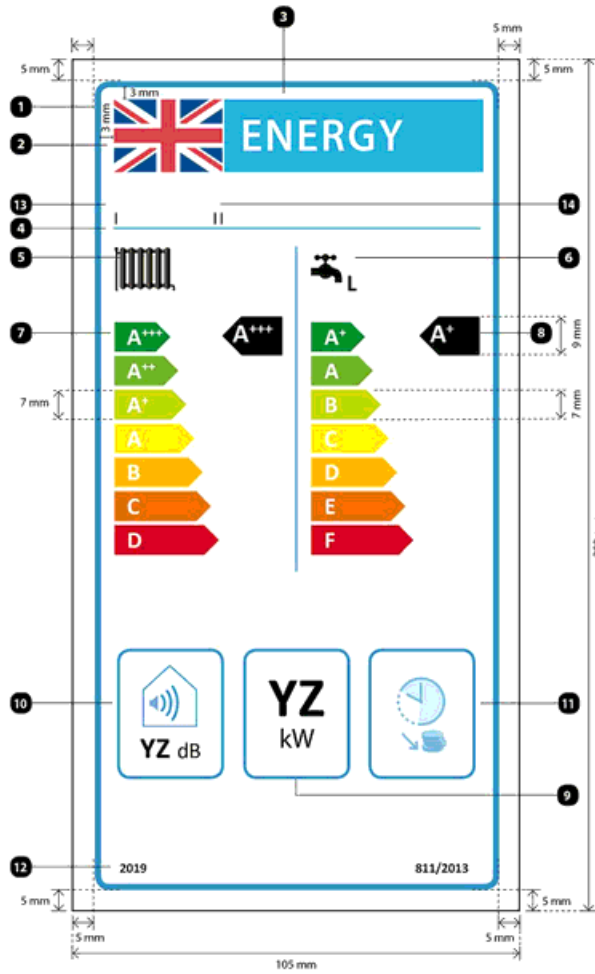

(15) In paragraph 10 (label design for heat pump combination heaters), for the label image substitute the following image—

Status: This is the original version (as it was originally made). This item of legislation is currently only available in its original format.

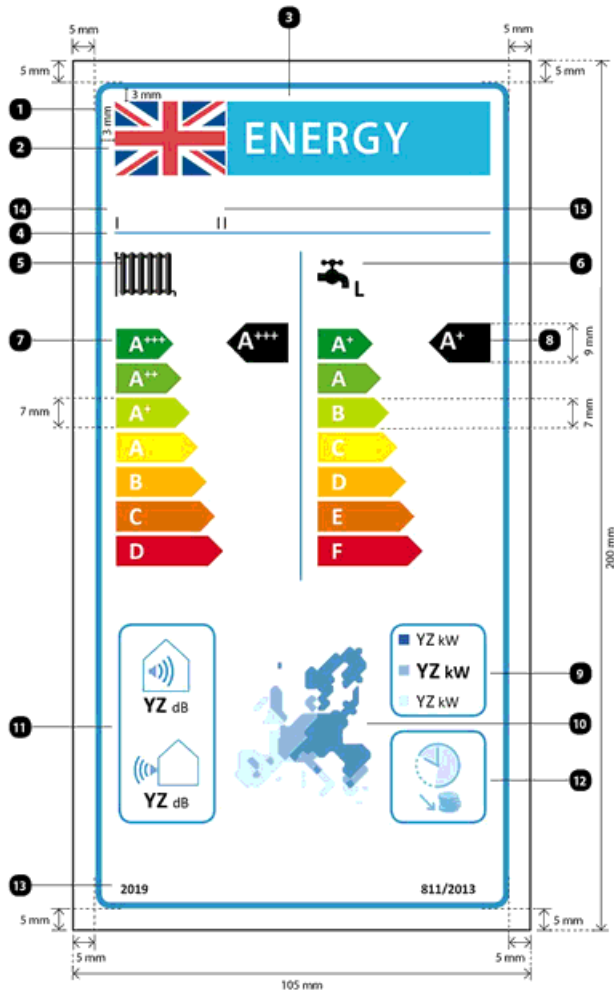

(16) In paragraph 11 (label design for packages of space heater, temperature control and solar device), for the label image substitute the following image—

Status: This is the original version (as it was originally made). This item of legislation is currently only available in its original format.

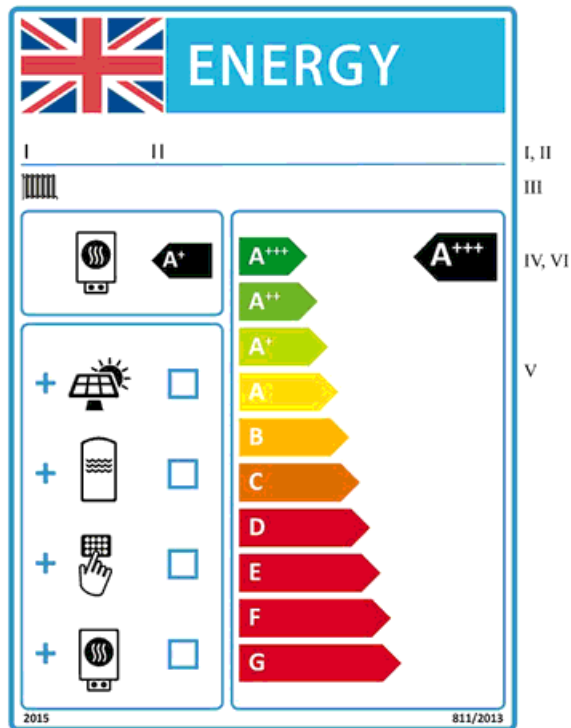

(17) In paragraph 12 (label design for packages of combination heater, temperature control and solar device), for the label image substitute the following image—

Status: This is the original version (as it was originally made). This item of legislation is currently only available in its original format.

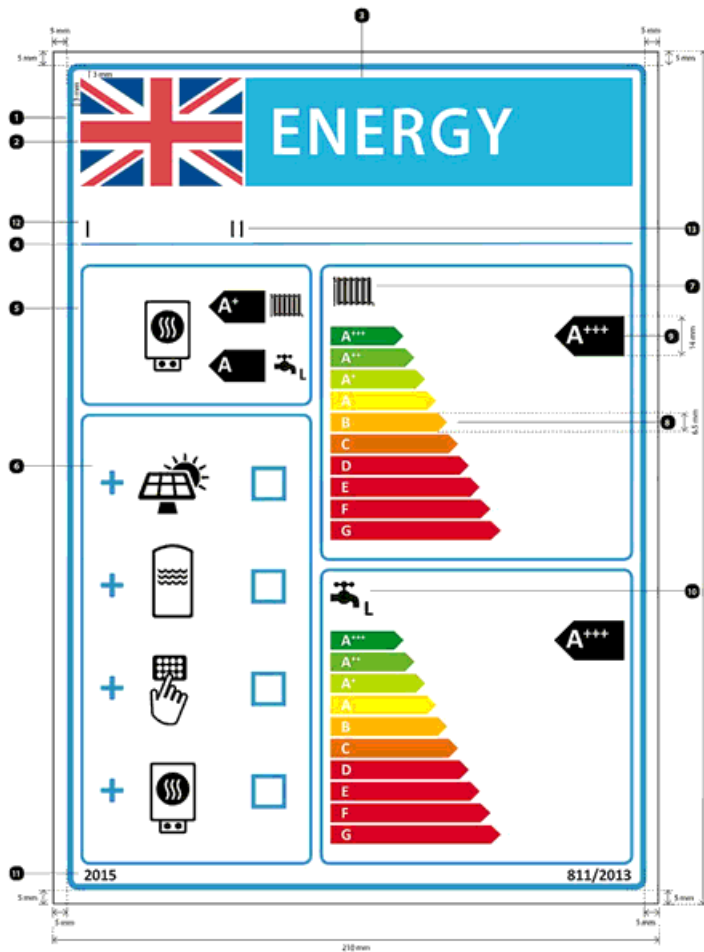

(18) In each of subparagraphs 5(d), 6(d), 7(d), 8(d), 9(d), 10(d), 11(d) and 12(d)—

(a) for point 2, substitute—

“UK flag: colours—

the blue background: 100,72,00,18.5;

the red crosses: 00,100,81,4

the remaining part: 100% white;”;

(b) in point 3, for “EU logo” substitute “UK flag”.

9.—(1) In Commission Delegated Regulation (EU) No 812/2013 of 18 February 2013 supplementing [Directive 2010/30/EU](#) of the European Parliament and of the Council with regard to the energy labelling of water heaters, hot water storage tanks and packages of water heater and solar device, Annex 3 (the labels) is amended as follows.

(2) In paragraph 1.2.1 (conventional water heaters in water heating energy efficiency classes A + to F), for the label image substitute the following image—

Status: This is the original version (as it was originally made). This item of legislation is currently only available in its original format.

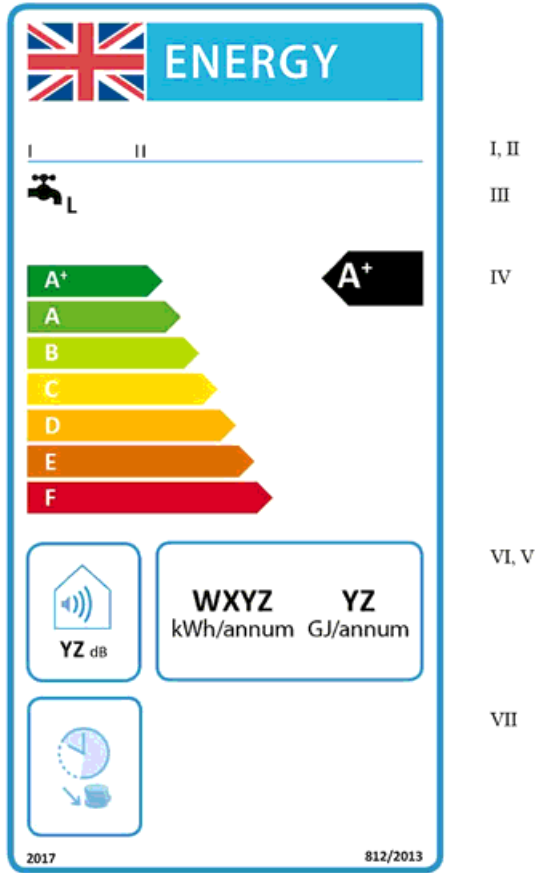

(3) In paragraph 1.2.2 (solar water heaters in water heating energy efficiency classes A+ to F), for the label image substitute the following image—

Status: This is the original version (as it was originally made). This item of legislation is currently only available in its original format.

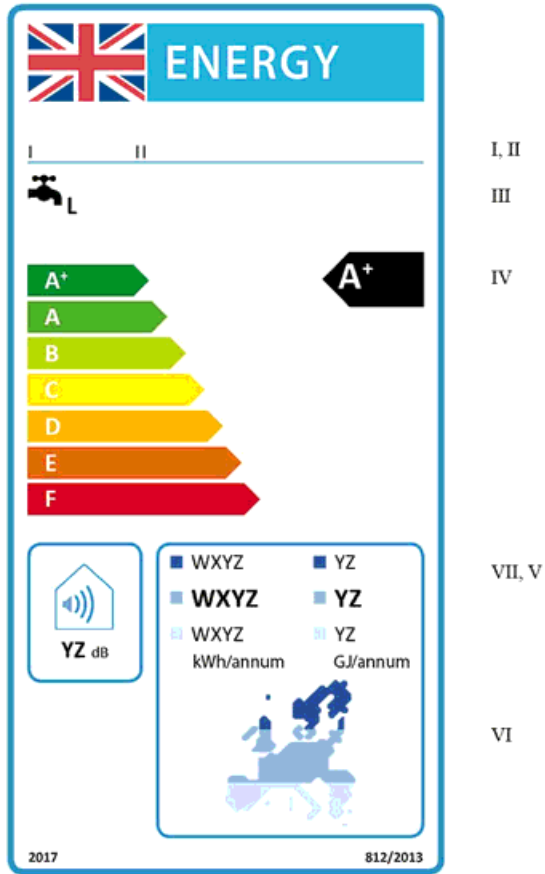

(4) In paragraph 1.2.3 (heat pump water heaters in water heating energy efficiency classes A+ to F), for the label image substitute the following image—

Status: This is the original version (as it was originally made). This item of legislation is currently only available in its original format.

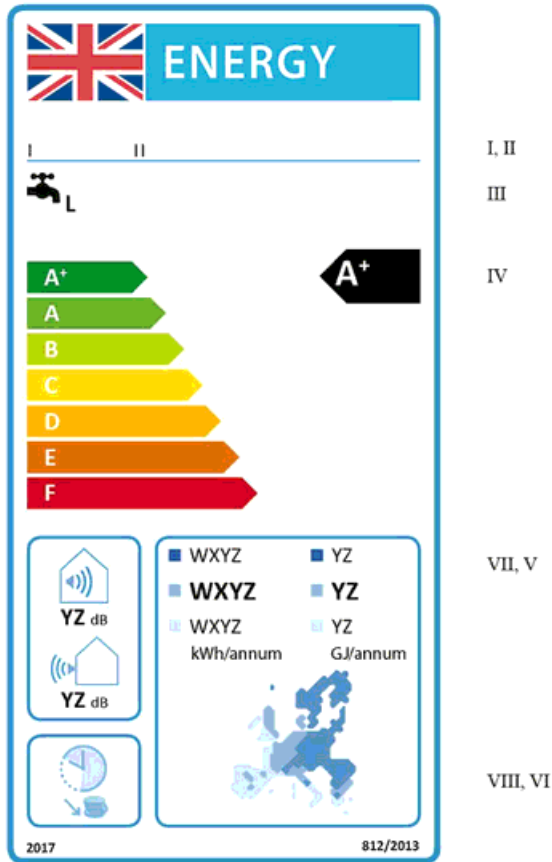

(5) In paragraph 2.2 (hot water storage tanks in energy efficiency classes A+ to F), for the label image substitute the following image—

Status: This is the original version (as it was originally made). This item of legislation is currently only available in its original format.

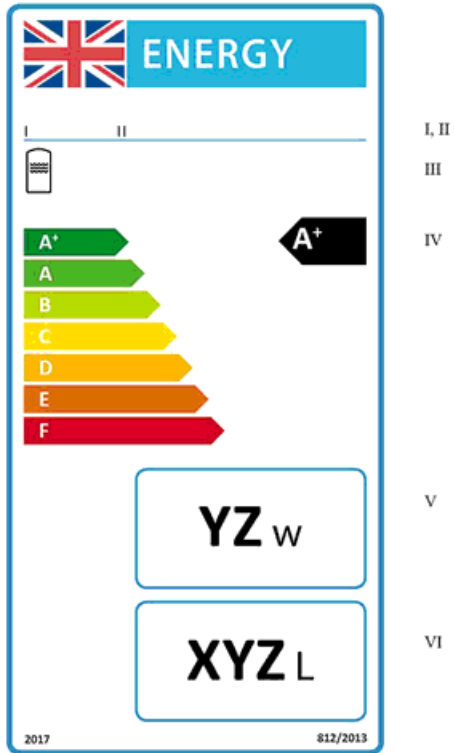

(6) In paragraph 3 (packages of water heater and solar device in energy efficiency classes A++ to G), for the label image substitute the following image—

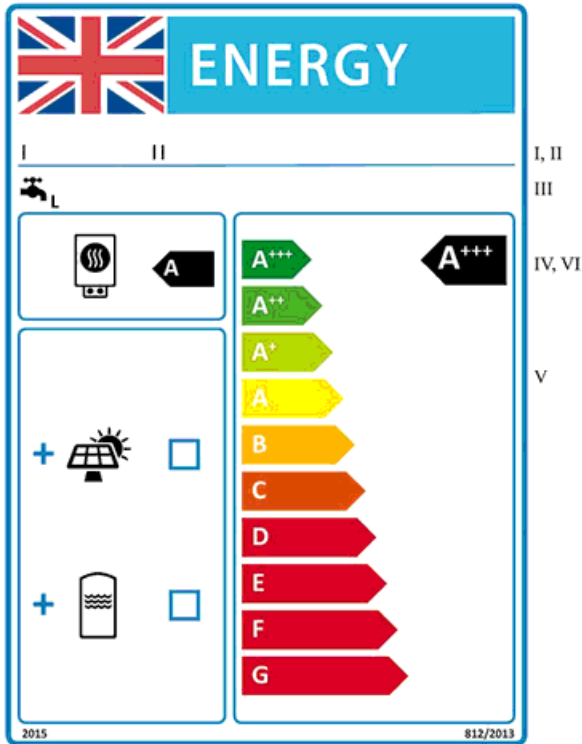

Status: This is the original version (as it was originally made). This item of legislation is currently only available in its original format.

(7) In paragraph 4 (label design for conventional water heaters), for the label image substitute the following image—

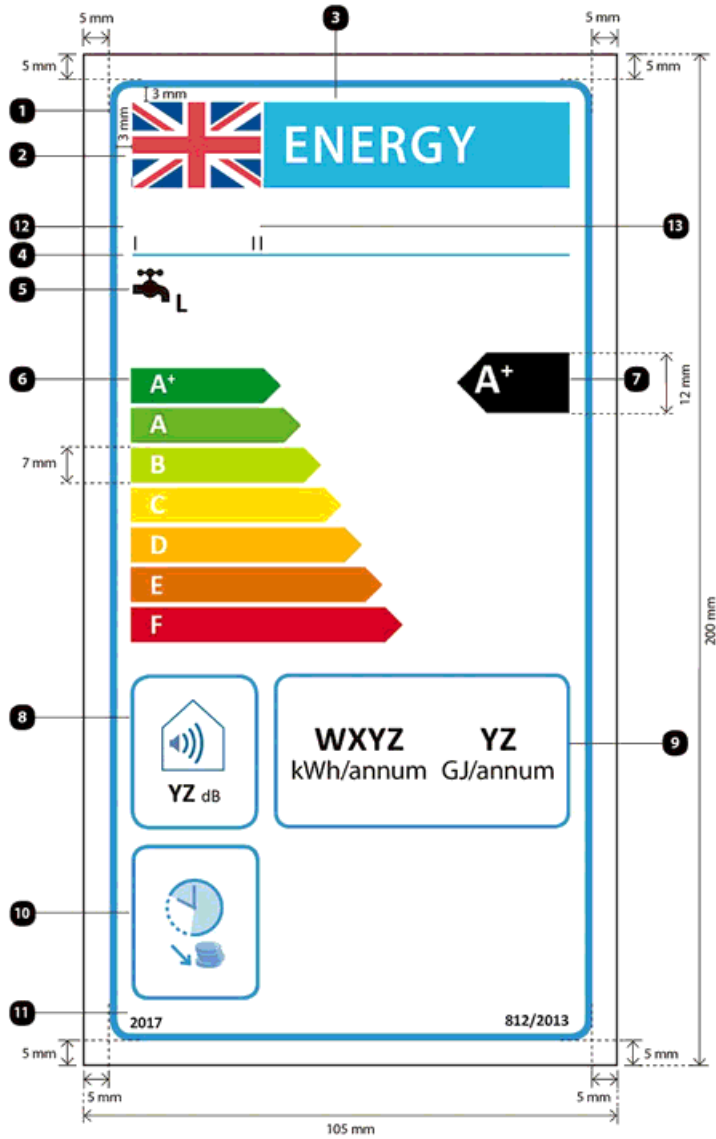

(8) In paragraph 5 (label design for solar water heaters), for the label image substitute the following image—

Status: This is the original version (as it was originally made). This item of legislation is currently only available in its original format.

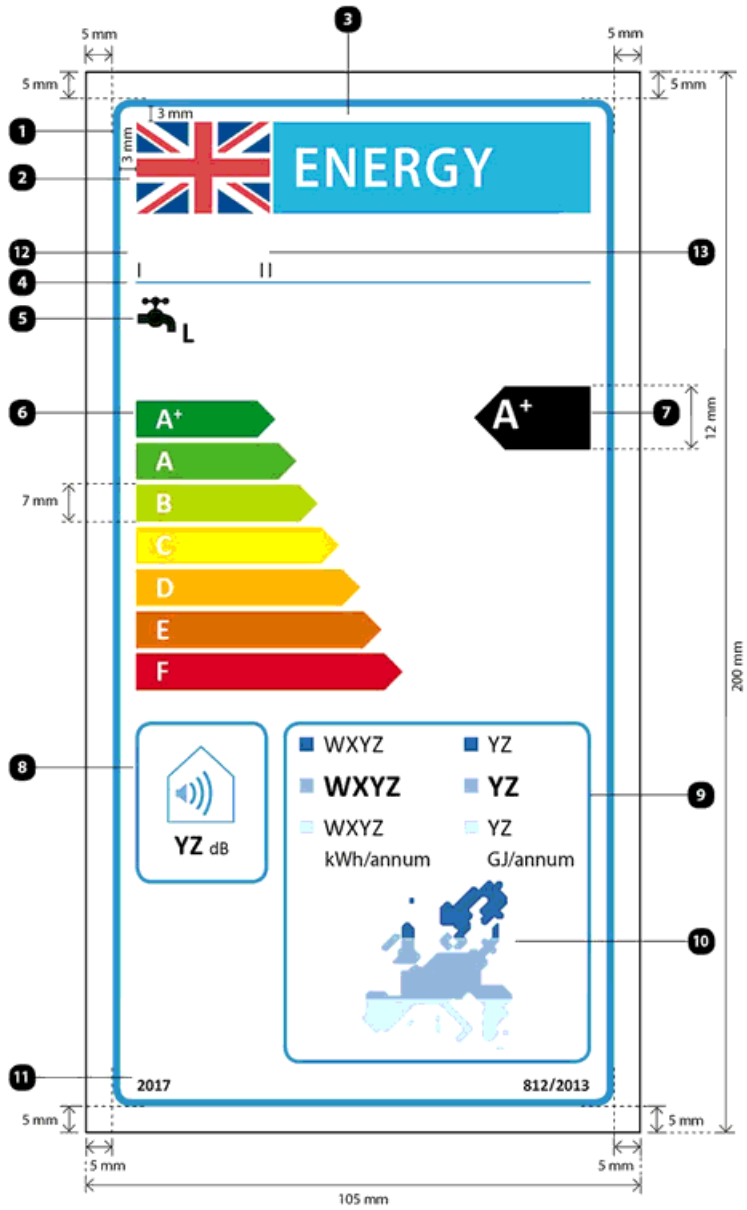

(9) In paragraph 6 (label design for heat pump water heaters), for the label image substitute the following image—

Status: This is the original version (as it was originally made). This item of legislation is currently only available in its original format.

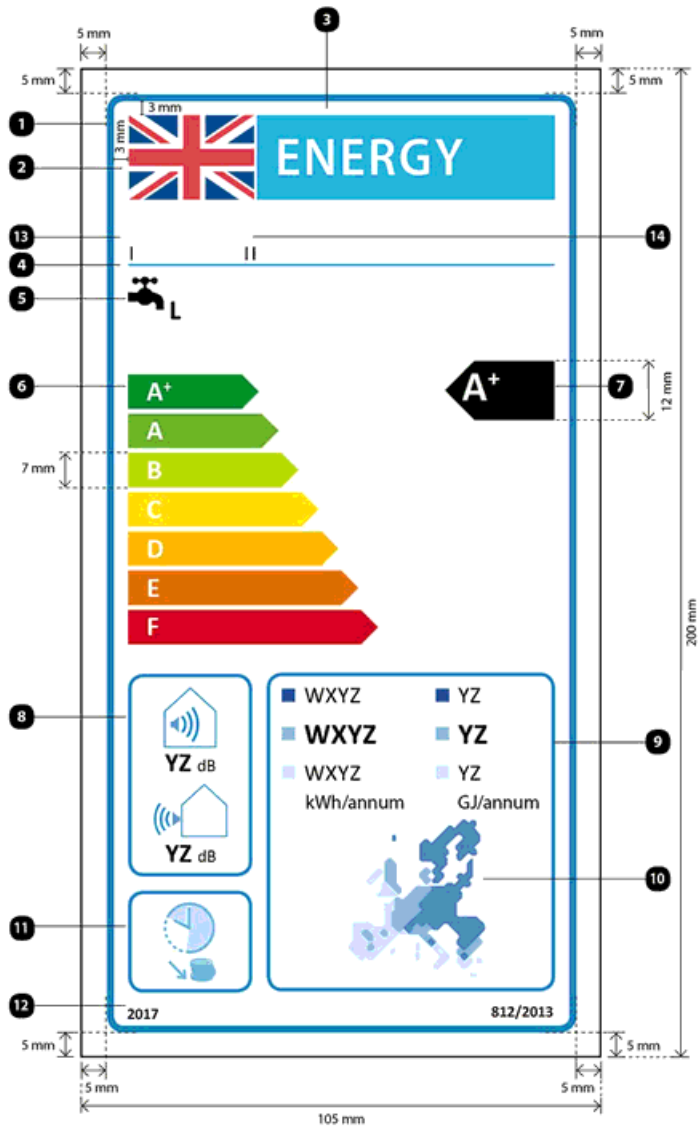

(10) In paragraph 7 (label design for hot water storage tanks), for the label image substitute the following image—

Status: This is the original version (as it was originally made). This item of legislation is currently only available in its original format.

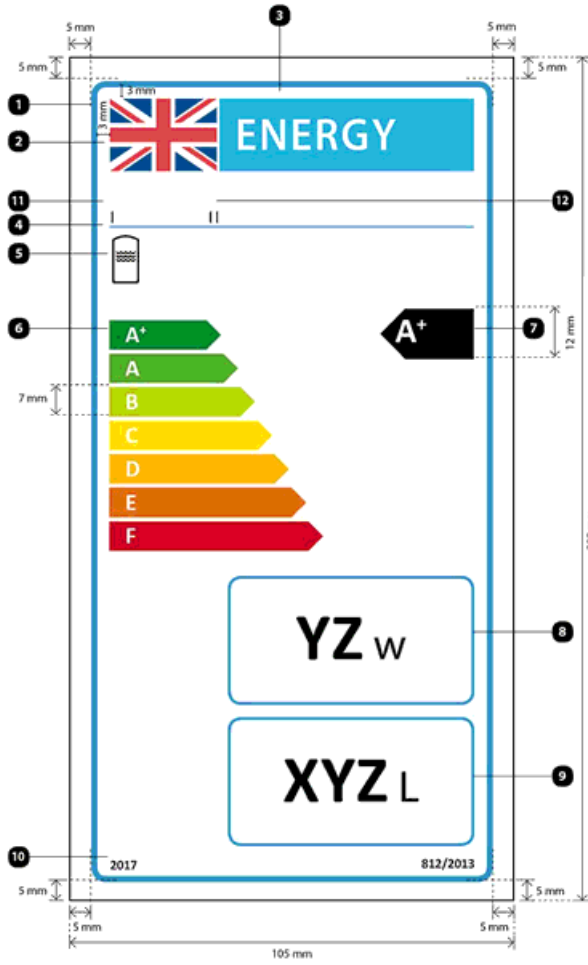

(11) In paragraph 8 (label design for packages of water heater and solar device), for the label image substitute the following image—

Status: This is the original version (as it was originally made). This item of legislation is currently only available in its original format.

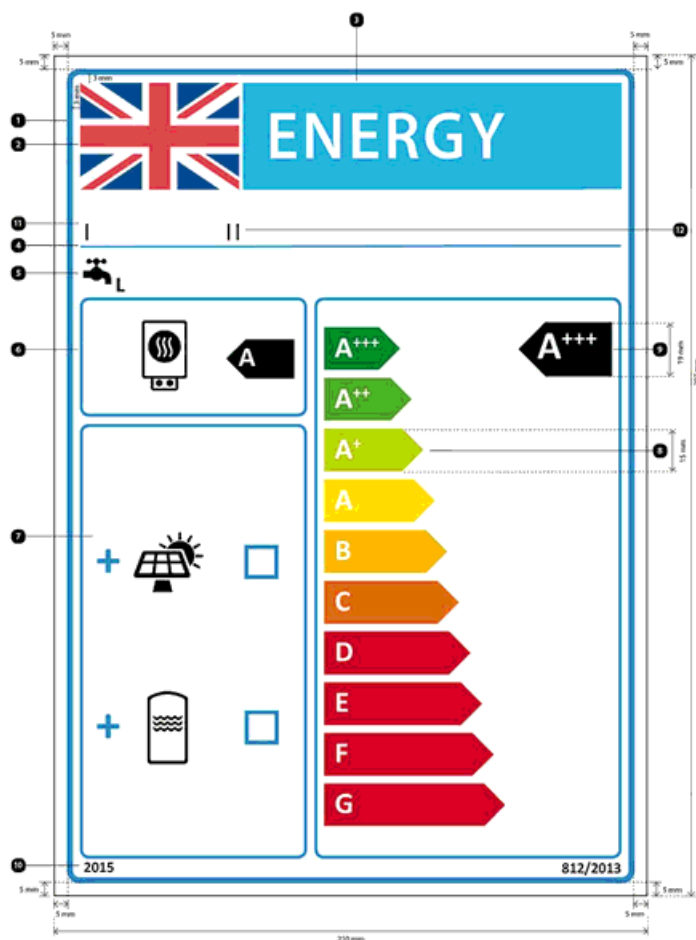

(12) In each of subparagraphs 4(d), 5(d), 6(d), 7(d) and 8(d)—

(a) for point 2, substitute—

“UK flag: colours—

the blue background: 100,72,00,18.5;

the red crosses: 00,100,81,4

the remaining part: 100% white;”;

(b) in point 3, for “EU logo” substitute “UK flag”.

10.—(1) In Commission Delegated Regulation (EU) No 874/2012 of 12 July 2012 supplementing [Directive 2010/30/EU](#) of the European Parliament and of the Council with regard to energy labelling of electrical lamps and luminaires, paragraph 1 of Annex 1 (label for electrical lamps presented at point of sale) is amended as follows.

(2) In subparagraph (1), for the label image, substitute the following image—

Status: This is the original version (as it was originally made). This item of legislation is currently only available in its original format.

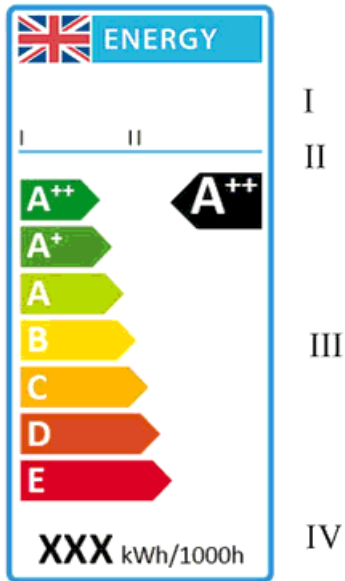

(3) In subparagraph (3), for the label images, substitute the following images—



Status: This is the original version (as it was originally made). This item of legislation is currently only available in its original format.

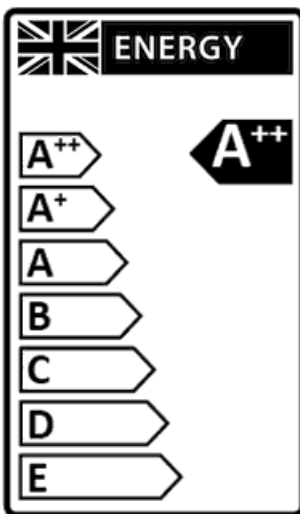
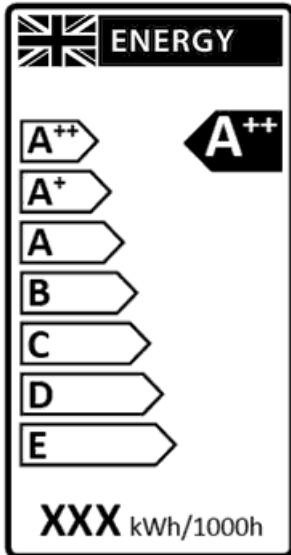
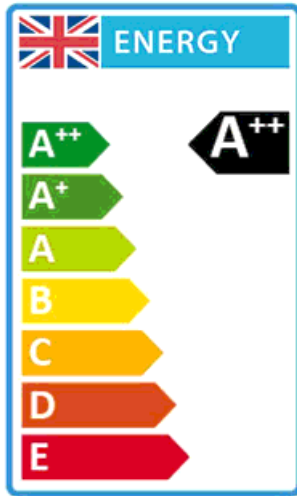

(4) In subparagraph (4)—

Status: This is the original version (as it was originally made). This item of legislation is currently only available in its original format.

(a) for the label image, substitute the following image—

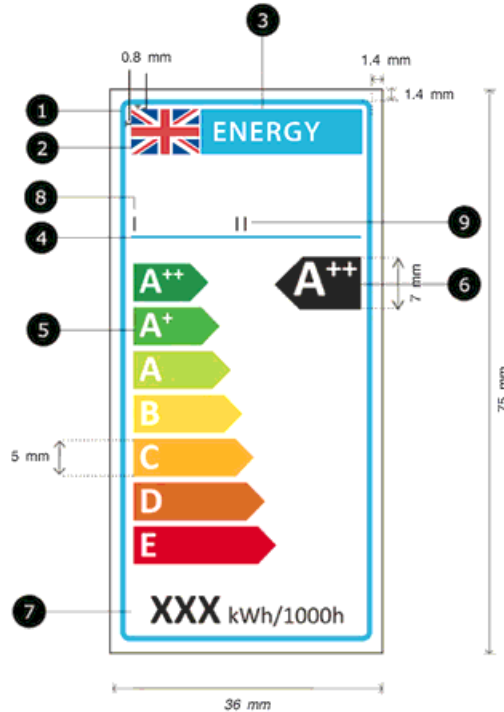

(b) in paragraph (d)—

(i) for point 2, substitute—

“UK flag: colours—

the blue background: 100,72,00,18.5;

the red crosses: 00,100,81,4

the remaining part: 100% white;”;

(ii) in point 3, for “EU logo” substitute “UK flag”.

11.—(1) In Commission Delegated Regulation (EU) No 65/2014 of 1 October 2013 supplementing [Directive 2010/30/EU](#) of the European Parliament and of the Council with regard to the energy labelling of domestic ovens and range hoods, Annex 3 (the label) is amended as follows.

(2) In subparagraph 1.1.1 (label presentation for each cavity of a domestic electric oven), for the label image, substitute the following image—

Status: This is the original version (as it was originally made). This item of legislation is currently only available in its original format.

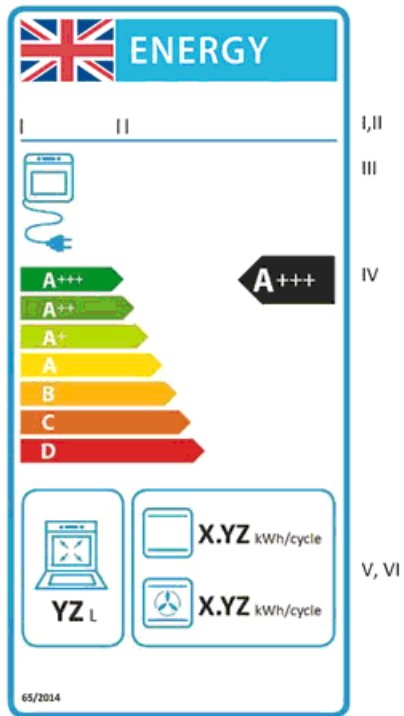

- (3) In subparagraph 1.1.3 (label design - domestic electric ovens)—
(a) for the label image, substitute the following image—

Status: This is the original version (as it was originally made). This item of legislation is currently only available in its original format.

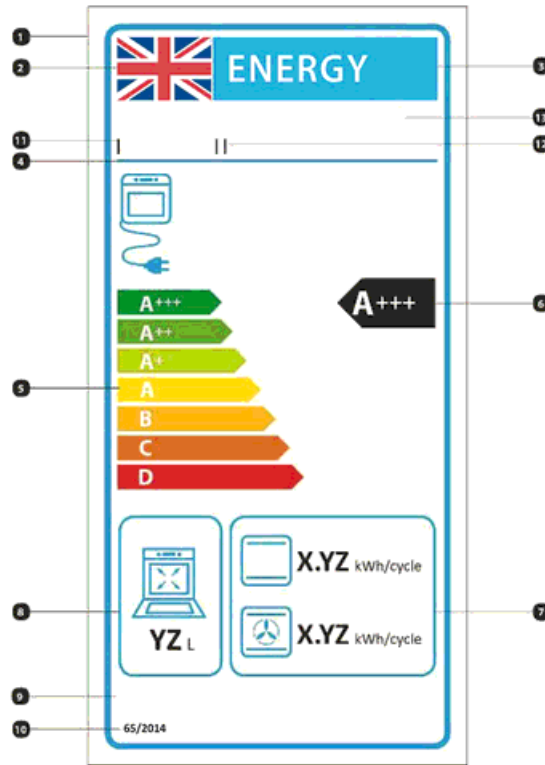

(b) in in subparagraph 1.1.3(iv)—

(i) for point 2, substitute—

“UK flag: colours—

the blue background: 100,72,00,18.5;

the red crosses: 00,100,81,4

the remaining part: 100% white;”;

(ii) in point 3, for “EU logo” substitute “UK flag”.

(4) In subparagraph 1.2.1 (label presentation for each cavity of a domestic gas oven), for the label image, substitute the following image—

Status: This is the original version (as it was originally made). This item of legislation is currently only available in its original format.

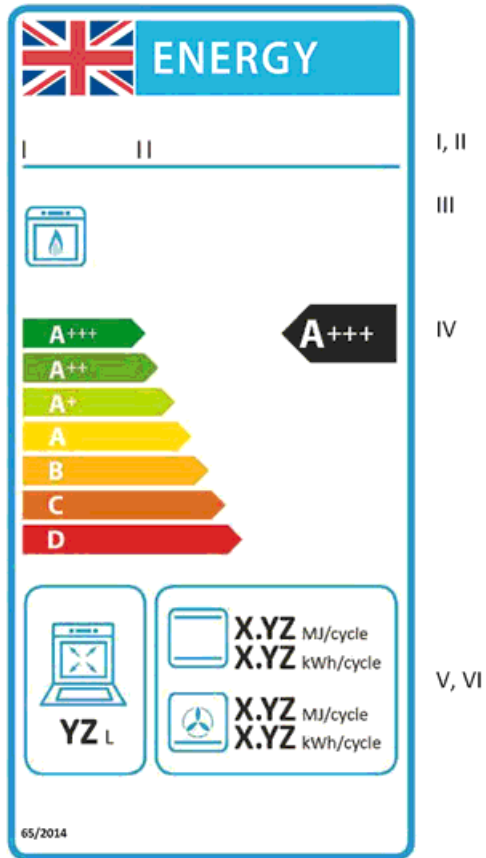

- (5) In subparagraph 1.2.3 (label design - domestic gas ovens)—
 - (a) for the label image, substitute the following image—

Status: This is the original version (as it was originally made). This item of legislation is currently only available in its original format.

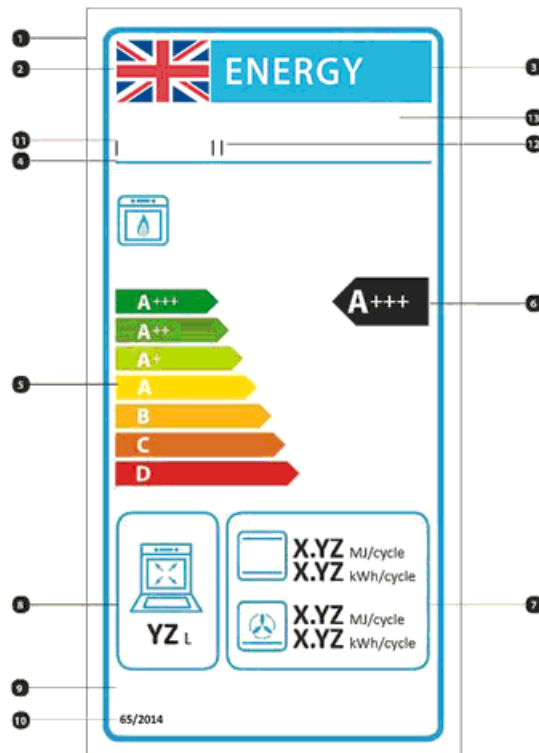

(b) in in subparagraph 1.2.3(iv)—

(i) for point 2, substitute—

“UK flag: colours—

the blue background: 100,72,00,18.5;

the red crosses: 00,100,81,4

the remaining part: 100% white;”;

(ii) in point 3, for “EU logo” substitute “UK flag”.

(6) In subparagraph 2.1.4 (label for domestic range hoods in energy efficiency classes A+++ to D (label 4)), for the label image, substitute the following image—

Status: This is the original version (as it was originally made). This item of legislation is currently only available in its original format.

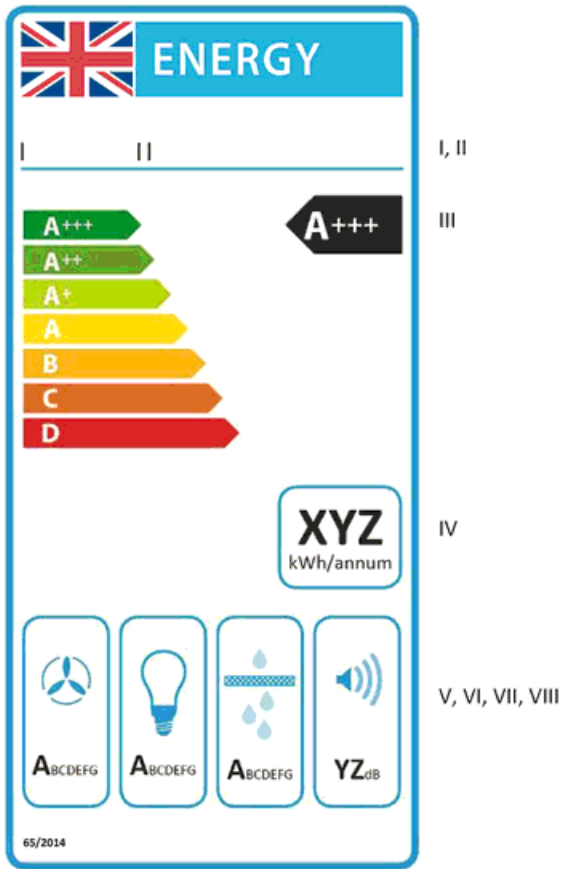

- (7) in subparagraph 2.3 (label design - domestic range hoods)—
 - (a) for the label image, substitute the following image—

Status: This is the original version (as it was originally made). This item of legislation is currently only available in its original format.

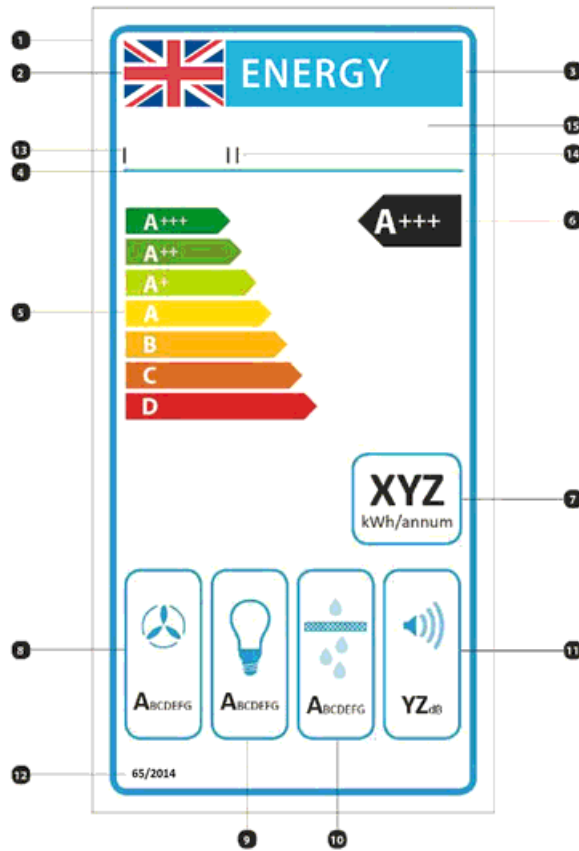

(b) in subparagraph 2.3(iv)—

(i) for point 2, substitute—

“UK flag: colours—

the blue background: 100,72,00,18.5;

the red crosses: 00,100,81,4

the remaining part: 100% white;”;

(ii) in point 3, for “EU logo” substitute “UK flag”.

12.—(1) In Commission Delegated Regulation (EU) No 1254/2014 of 11 July 2014 supplementing [Directive 2010/30/EU](#) of the European Parliament and of the Council with regard to energy labelling of residential ventilation units, Annex 3 (the label) is amended as follows.

(2) In paragraph 1 (label for UVUs marketed after 1 January 2016), for the label image, substitute the following image—

Status: This is the original version (as it was originally made). This item of legislation is currently only available in its original format.

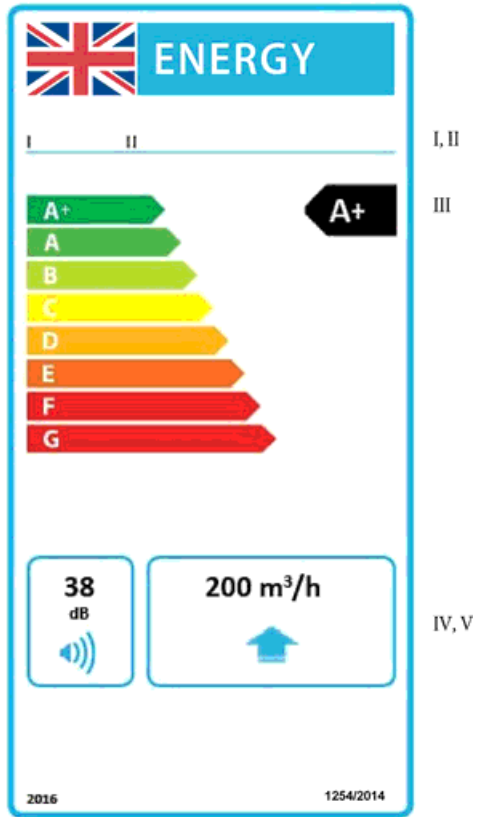

(3) In paragraph 2 (label for BVUs marketed after 1 January 2016), for the label image, substitute the following image—

Status: This is the original version (as it was originally made). This item of legislation is currently only available in its original format.

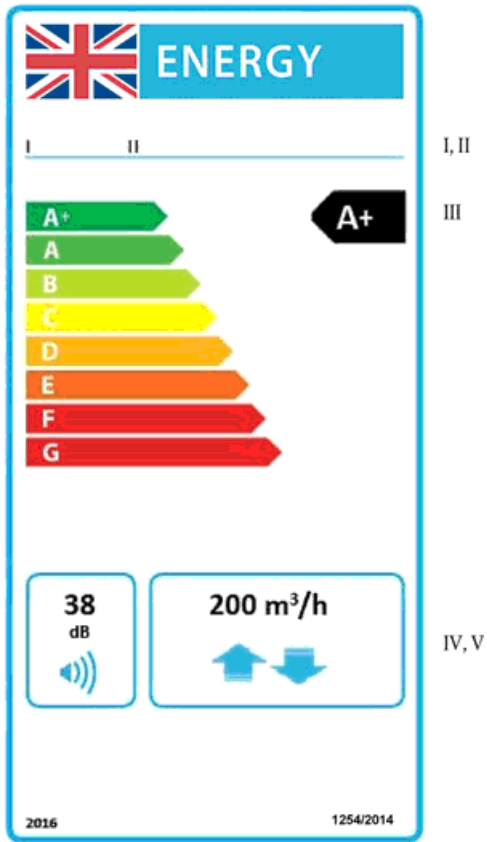

(4) In paragraph 3 (design of the labels)—

(a) for the label image, substitute the following image—

Status: This is the original version (as it was originally made). This item of legislation is currently only available in its original format.

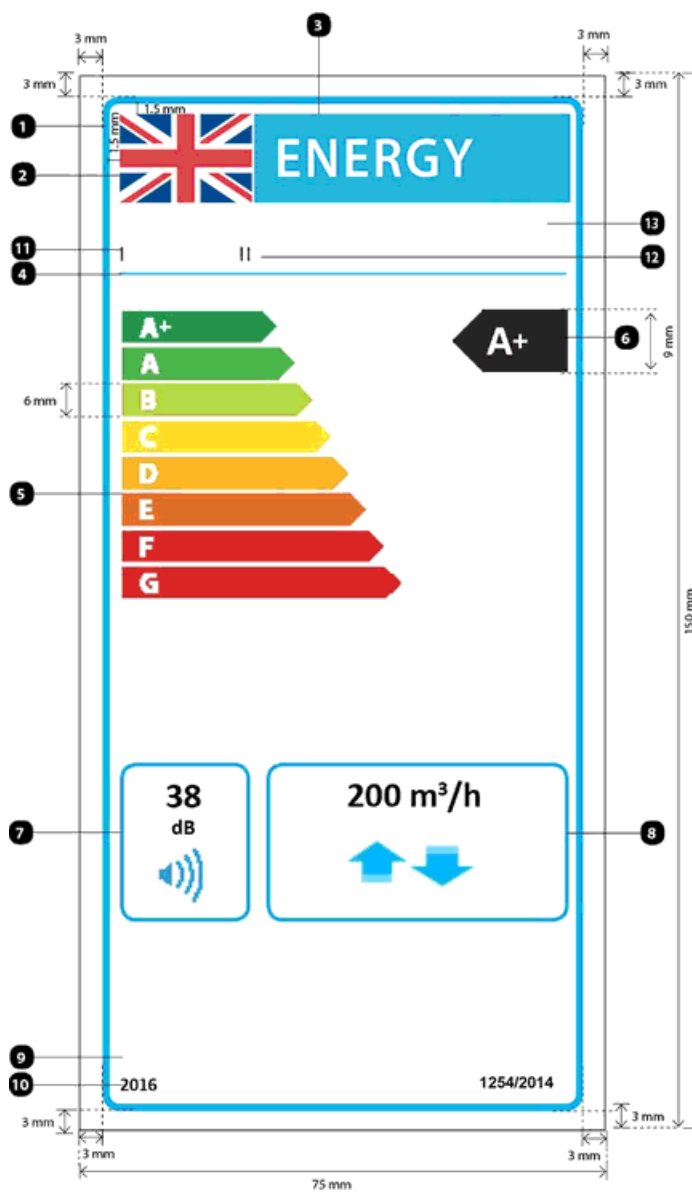

(b) in the final subparagraph—

(i) for point 2, substitute—

“UK flag: colours—

the blue background: 100,72,00,18.5;

the red crosses: 00,100,81,4

the remaining part: 100% white;”;

(ii) in point 3, for “EU logo” substitute “UK flag”.

13.—(1) In Commission Delegated Regulation (EU) No 2015/1094 of 5 May 2015 supplementing [Directive 2010/30/EU](#) of the European Parliament and of the Council with regard to the energy labelling of professional refrigerated storage cabinets, Annex 3 (labels) is amended as follows.

Status: This is the original version (as it was originally made). This item of legislation is currently only available in its original format.

(2) In paragraph 2 (professional refrigerated storage cabinets in energy efficiency classes A+++ to G), for the label image, substitute the following image—

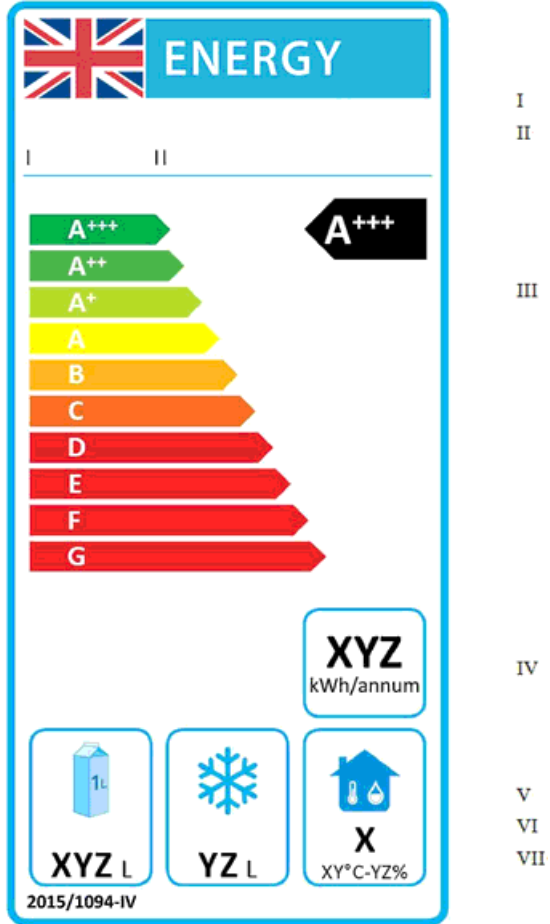

(3) In paragraph 3 (design of the label)—

(a) for the label image, substitute the following image—

Status: This is the original version (as it was originally made). This item of legislation is currently only available in its original format.

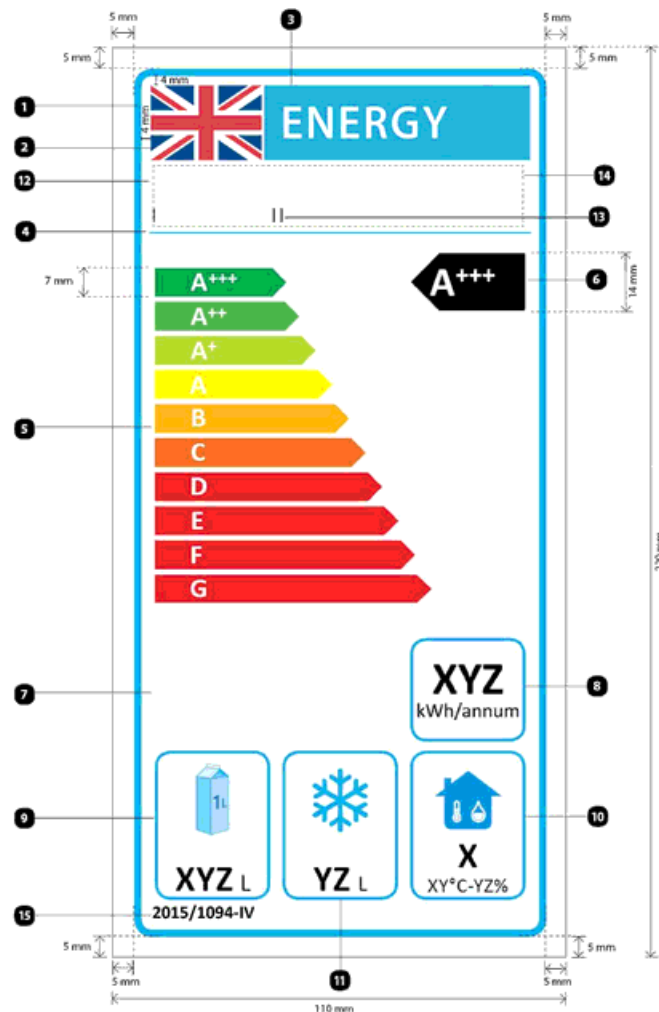

(b) in subparagraph (d)—

(i) for point 2, substitute—

“UK flag: colours—

the blue background: 100,72,00,18.5;

the red crosses: 00,100,81,4

the remaining part: 100% white;”;

(ii) in point 3, for “EU logo” substitute “UK flag”;

(iii) omit point 7.

14.—(1) In Commission Delegated Regulation (EU) No 2015/1186 of 24 April 2015 supplementing [Directive 2010/30/EU](#) of the European Parliament and of the Council with regard to the energy labelling of local space heaters, Annex 3 (the label) is amended as follows.

(2) In paragraph 1 (local space heaters), for the label image, substitute the following image—

Status: This is the original version (as it was originally made). This item of legislation is currently only available in its original format.

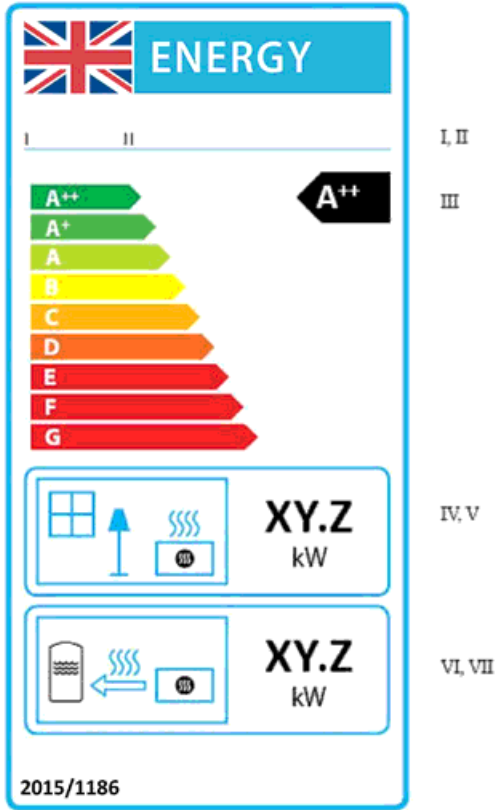

- (3) In paragraph 2 (the design of the label)—
 - (a) for the label image, substitute the following image—

Status: This is the original version (as it was originally made). This item of legislation is currently only available in its original format.

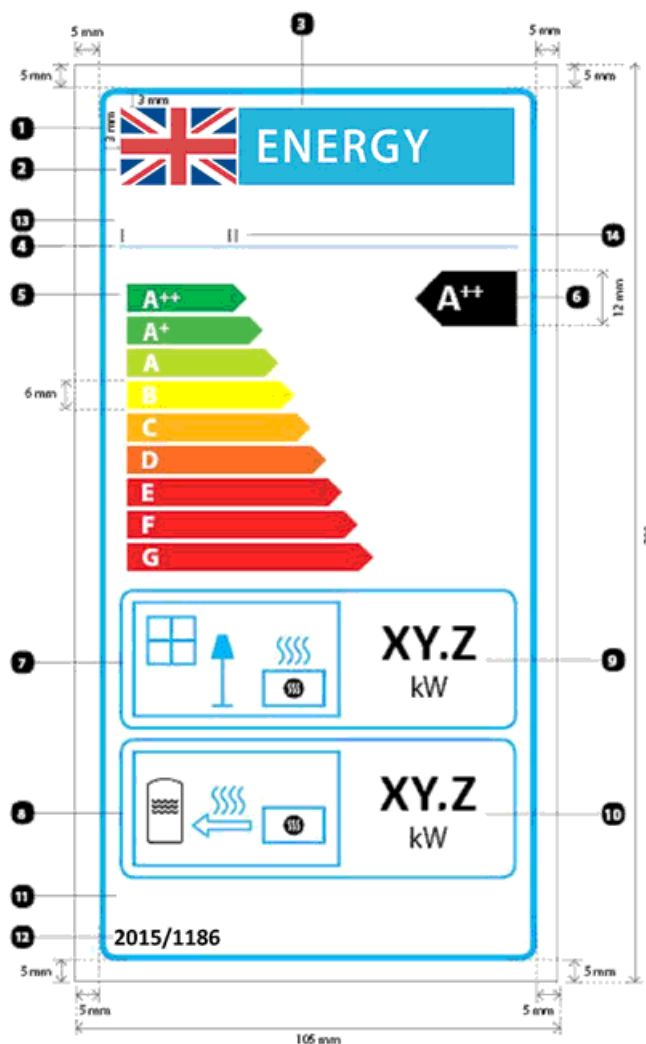

(b) in subparagraph (d)—

(i) for point 2, substitute—

“UK flag: colours—

the blue background: 100,72,00,18.5;

the red crosses: 00,100,81,4

the remaining part: 100% white;”;

(ii) in point 3, for “EU logo” substitute “UK flag”.

15.—(1) In Commission Delegated Regulation (EU) No 2015/1187 of 27 April 2015 supplementing [Directive 2010/30/EU](#) of the European Parliament and of the Council with regard to the energy labelling of solid fuel boilers and packages of a solid fuel boiler, Annex 3 (the labels) is amended as follows.

(2) In paragraph 1.2 (label 2), for the label image, substitute the following image—

Status: This is the original version (as it was originally made). This item of legislation is currently only available in its original format.

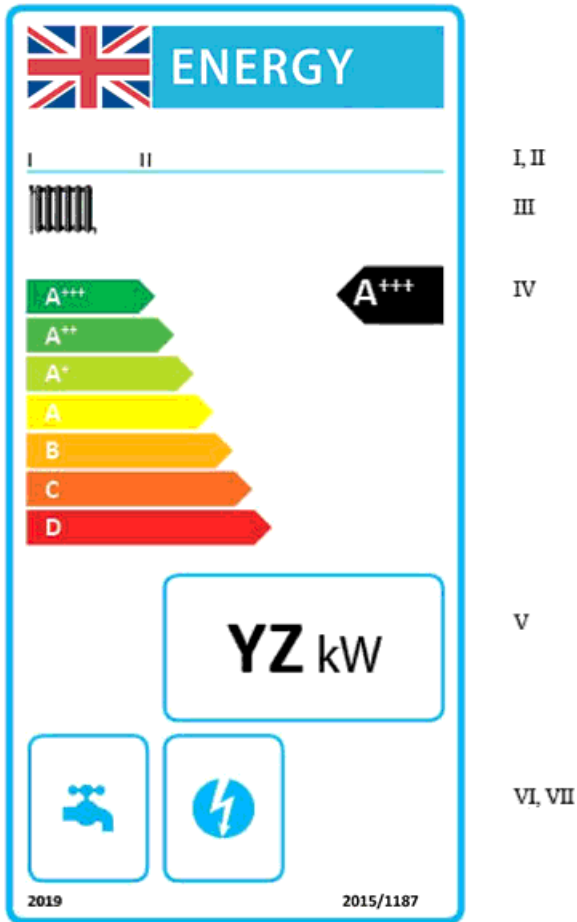

(3) In paragraph 2 (packages of a solid fuel boiler, etc.), for the label image, substitute the following image—

Status: This is the original version (as it was originally made). This item of legislation is currently only available in its original format.

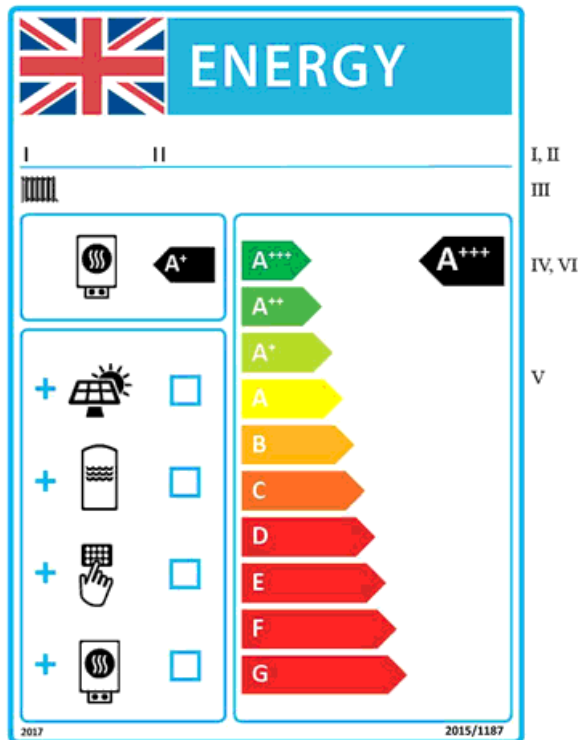

- (4) In paragraph 3 (design of the label for solid fuel boilers)—
(a) for the label image, substitute the following image—

Status: This is the original version (as it was originally made). This item of legislation is currently only available in its original format.

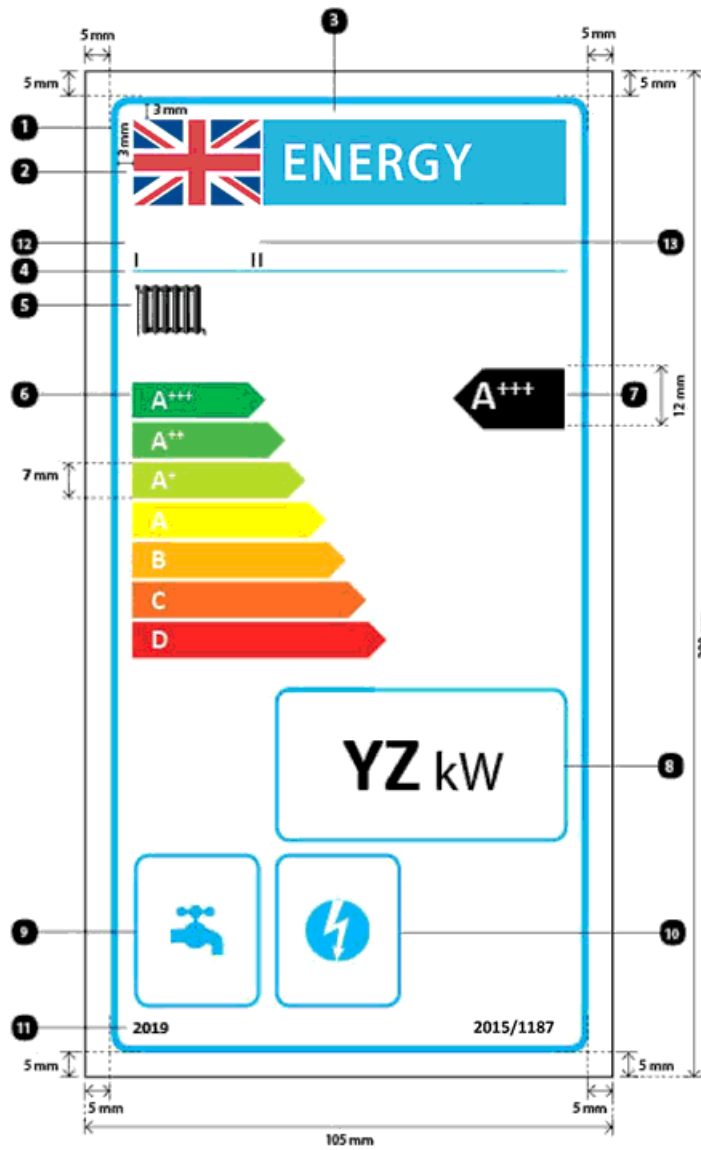

- (b) in subparagraph (d)—
 - (i) for point 2, substitute—
 - “UK flag: colours—
 - the blue background: 100,72,00,18.5;
 - the red crosses: 00,100,81,4
 - the remaining part: 100% white;”;
 - (ii) in point 3, for “EU logo” substitute “UK flag”.
- (5) In paragraph 4 (design of the label for packages of a solid fuel boiler)—
 - (a) for the label image, substitute the following image—

