

This Statutory Instrument has been made in consequence of defects in S.I. 2000/1970 and is being issued free of charge to all known recipients of that Statutory Instrument

STATUTORY INSTRUMENTS

2000 No. 3318

DISABLED PERSONS

**The Public Service Vehicles Accessibility
(Amendment) Regulations 2000**

<i>Made</i>	- - - -	<i>18th December 2000</i>
<i>Laid before Parliament</i>		<i>21st December 2000</i>
<i>Coming into force</i>	- -	<i>15th January 2001</i>

The Secretary of State, in exercise of the powers conferred on him by section 40(1) and (2) and 67 of the Disability Discrimination Act 1995(1), hereby makes the following Regulations:

Citation and commencement

1. These Regulations may be cited as the Public Service Vehicles Accessibility (Amendment) Regulations 2000 and shall come into force on 15th January 2001.

Amendments to the Public Service Vehicles Accessibility Regulations 2000

2. The Public Service Vehicles Accessibility Regulations 2000(2) shall be amended in accordance with the following provisions of these Regulations.

3. In Schedule 1—

(1) in Part I, for paragraph 10(2) (lighting) shall be substituted—

“(2) Any lighting fitted to a regulated public service vehicle in accordance with subparagraph (1) shall have a means of preventing its operation when the vehicle is in motion if its use is likely to affect adversely the driver’s vision.”

(2) in Part II, for the diagram entitled “Diagram A—Wheelchair Dimensions” shall be substituted the diagram shown in the Schedule to these Regulations.

4. In Schedule 2—

(1) 1995 c. 50.
(2) S.I. 2000/1970.

Status: This is the original version (as it was originally made). This item of legislation is currently only available in its original format.

(1) in paragraph 1 (definitions), in the definition of “total floor area” after the word “regulated” shall be inserted the word “public”;

(2) in paragraph 4(4)(a) (steps), for the word “is” in the second place where it occurs, shall be substituted the word “it”; and

(3) in paragraph 5(1)(a)(ii) (handrails and handholds), for the words “from the floor to the ceiling, or to” shall be substituted the words “from the floor or, where there is a wheel arch or similar structure, from the lowest height which is practicable to, in either case, the ceiling or”.

5. In Schedule 3, paragraph 1, for the word “kilometer(s)” in the definition of “km/h” shall be substituted the word “kilometre(s)”.

Signed by authority of the Secretary of State for the Environment, Transport and the Regions

Keith Hill
Parliamentary Under-Secretary of State,
Department of the Environment, Transport and
the Regions

18th December 2000

Status: This is the original version (as it was originally made). This item of legislation is currently only available in its original format.

SCHEDULE

Diagram A—Wheelchair Dimensions

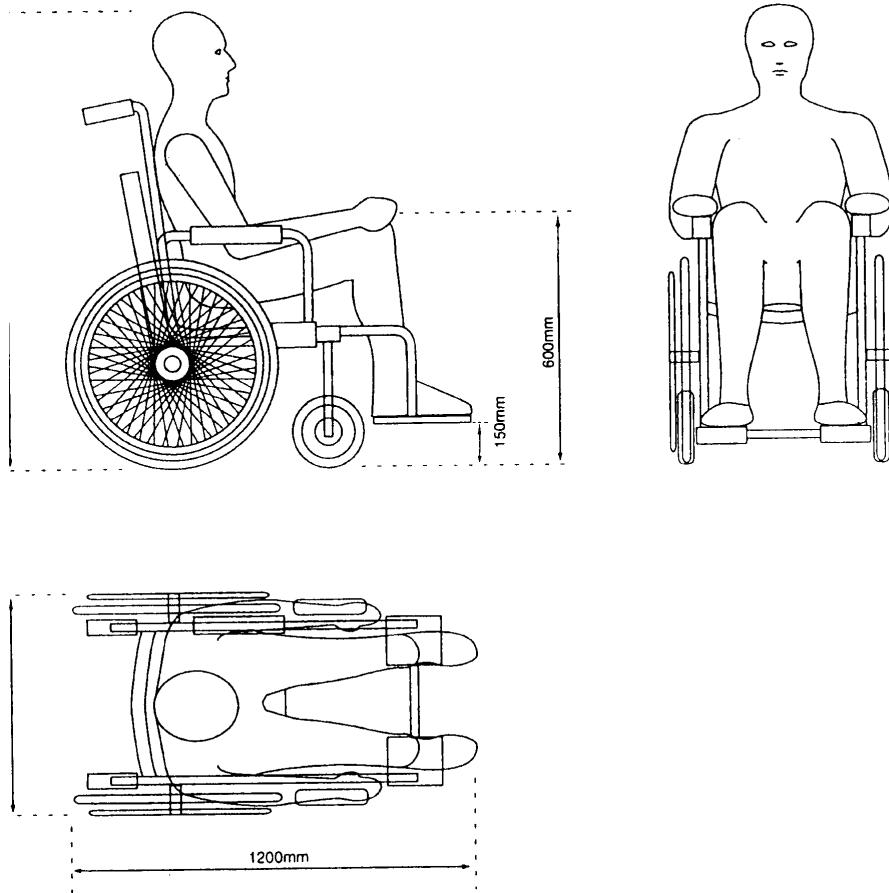

EXPLANATORY NOTE

(This note is not part of the Regulations)

These Regulations amend the Public Service Accessibility Regulations 2000 ([S.I. 2000/1970](#)) by correcting a number of errors and making two minor amendments. The principal changes are as follows.

In Schedule 1—

- (a) paragraph 10(2) (which relates to the interior and exterior illumination of regulated public service vehicles) is amended to permit the use of a manual, as well as an automatic, means of preventing the lighting adversely affecting the driver's vision; and

Status: This is the original version (as it was originally made). This item of legislation is currently only available in its original format.

- (b) in Part II, an error in Diagram A (which shows wheelchair dimensions) is corrected by the substitution of a new diagram which shows that the measurement of 150mm should be made from ground level to the bottom of the footrest on which the wheelchair user's foot is placed rather than from ground level to the top of the wheelchair user's foot.

In Schedule 2, the requirement in paragraph 5 that the height which a handrail is to extend be measured from the floor of the vehicle is altered so that, in cases where there is a wheel arch or similar structure, the measurement may be made from the lowest height that is practicable.

A copy of these Regulations will be available free of charge to past and present purchasers of the Public Service Vehicles Accessibility Regulations 2000.