

SCHEDULE 2

(Regulation 15)

“SCHEDULE 19

(Regulations 18 & 20)

PART I

REQUIREMENTS RELATING TO OBLIGATORY REAR MARKINGS AND
OPTIONAL REAR MARKINGS TO THE EXTENT SPECIFIED IN PART II

GENERAL REQUIREMENTS

1. Description—	A rear marking of a type shown in diagram 1, 2, 3 or 4 in Part IV of this Schedule
(a) A motor vehicle first used on or after 1 April 1996, the overall length of which—	
(i) does not exceed 13m:	
(ii) exceeds 13m:	A rear marking of a type shown in diagram 5, 6, 7 or 8 in Part IV of this Schedule
(b) A motor vehicle first used before 1 April 1996, the overall length of which—	A rear marking of a type shown in diagram 1, 2 or 3 in Part III of this Schedule or a rear marking of a type shown in diagram 1, 2, 3 or 4 in Part IV of this Schedule
(i) does not exceed 13m:	
(ii) exceeds 13m:	A rear marking of a type shown in diagram 4 or 5 in Part III of this Schedule or a rear marking of a type shown in diagram 5, 6, 7 or 8 in Part IV of this Schedule
(c) A trailer manufactured on or after 1 October 1995 if it forms part of a combination of vehicles the overall length of which—	A rear marking of a type shown in diagram 1, 2, 3 or 4 in Part IV of this Schedule
(i) does not exceed 11m:	
(ii) exceeds 11m but does not exceed 13m:	A rear marking of a type shown in Part IV of this Schedule
(iii) exceeds 13m:	A rear marking of a type shown in diagram 5, 6, 7 or 8 in Part IV of this Schedule
(d) A trailer manufactured before 1 October 1995 if it forms part of a combination of vehicles the overall length of which—	A rear marking of a type shown in diagram 1, 2 or 3 in Part III of this Schedule or a rear marking of a type shown in diagram 1, 2, 3 or 4 in Part IV of this Schedule
(i) does not exceed 11m:	
(ii) exceeds 11m but does not exceed 13m:	A rear marking of a type shown in Part III or Part IV of this Schedule
(iii) exceeds 13m:	A rear marking of a type shown in diagram 4 or 5 in Part III of this Schedule or a rear marking

Status: This is the original version (as it was originally made). This item of legislation is currently only available in its original format.

- of a type shown in diagram 5, 6, 7 or 8 in Part IV of this Schedule
2. Position—
- (a) Longitudinal: At or near the rear of the vehicle
- (b) Lateral—
- (i) A rear marking of a type shown in diagram 2, 3 or 5 in Part III of this Schedule and a rear marking of a type shown in diagram 2, 3, 4, 6, 7 or 8 in Part IV of this Schedule: Each part shall be fitted as near as practicable to the outermost edge of the vehicle on the side thereof on which it is fitted so that no part of the marking projects beyond the outermost part of the vehicle on either side
- (ii) A rear marking of a type shown in diagram 1 or 4 in Part III of this Schedule and a rear marking of a type shown in diagram 1 or 5 in Part IV of this Schedule: The marking shall be fitted so that the vertical centre-line of the marking lies on the vertical plane through the longitudinal axis of the vehicle and no part of the marking projects beyond the outermost part of the vehicle on either side
- (c) Vertical: The lower edge of every rear marking shall be at a height of not more than 1700mm nor less than 400mm above the ground whether the vehicle is laden or unladen
3. Visibility: Plainly visible to the rear
4. Alignment: The lower edge of every rear marking shall be fitted horizontally. Every part of a rear marking shall lie within 20° of a transverse vertical plane at right angles to the longitudinal axis of the vehicle and shall face to the rear
5. Markings—
- (a) A motor vehicle or trailer not covered by sub-paragraph (b): In respect of any rear marking of a type shown in Part III of this Schedule a British Standard mark or in respect of any rear marking of a type shown in Part IV of this Schedule an approval mark
- (b) A motor vehicle first used on or after 1 April 1996 and a trailer manufactured on or after 1 October 1995: An approval mark
6. Colour: Red fluorescent material in the stippled areas shown in any of the diagrams in Part III or IV of this Schedule and yellow retro reflective material in any of the areas so shown, being areas not stippled and not constituting a letter. All letters shall be coloured black
-
7. Other requirements—
- A rear marking of a type shown in a diagram in Part III of this Schedule shall comply with the requirements of that Part.

The two parts of every rear marking of a type shown in diagrams 2, 3 and 5 in Part III and diagrams 2, 3, 6 and 7 in Part IV of this Schedule shall form a pair and the four parts of every rear marking of a type shown in diagrams 4 and 8 in Part IV of this Schedule shall form two pairs.

8. Definitions—

In this Schedule—

- (a) “approval mark” means a marking designated as an approval mark by regulation 3 of the Designation of Approval Marks Regulations⁽¹⁾ and shown at item 70 of Schedule 2 to those Regulations; and
- (b) “British Standard mark” means the specification for rear markings for vehicles published by the British Standards Institution under the reference BS AU 152: 1970, namely “BS AU 152”.

PART II

REQUIREMENTS RELATING TO OPTIONAL REAR MARKINGS

Subject to regulation 11(2), any number of rear markings shown in Parts III and IV may be fitted to the rear of a vehicle.

(1) The Designation of Approval Marks Regulations is defined in Regulation 3(2) of the Road Vehicles Lighting Regulations 1989 as meaning the [Motor Vehicles \(Designation of Approval Marks\) Regulations 1979 \(S.I. 1979/ 1088\)](#). The relevant amendment to those regulations is [S.I. 1990/1838](#).

Status: This is the original version (as it was originally made). This item of legislation is currently only available in its original format.

PART III

REAR MARKINGS PRESCRIBED FOR MOTOR VEHICLES FIRST USED BEFORE 1 APRIL 1996 AND TRAILERS MANUFACTURED BEFORE 1 OCTOBER 1995

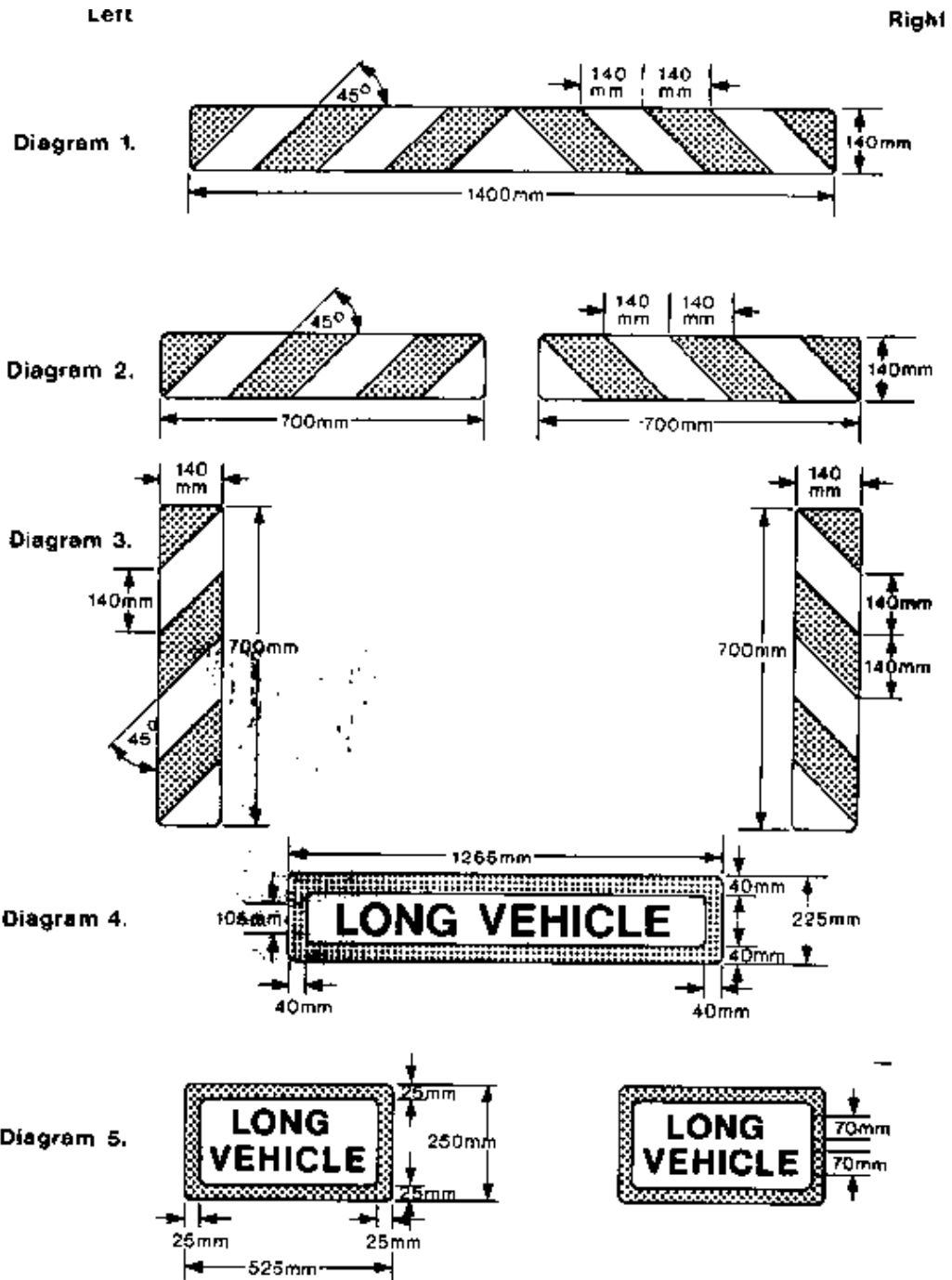

ADDITIONAL PROVISIONS RELATING TO THE ABOVE DIAGRAMS

1. A rear marking of a type shown in one of the above diagrams shall have the dimensions shown in relation to that diagram.

2. Any variation in a dimension (other than as to the height of a letter) specified in any of the above diagrams shall be treated as permitted for the purposes of this Schedule if the variation—
 - (a) in the case of a dimension so specified as 250mm or as over 250mm does not exceed 2.5 per cent of that dimension;
 - (b) in the case of a dimension so specified as 40mm or as over 40mm but as under 250mm does not exceed 5 per cent of that dimension; or
 - (c) in the case of a dimension so specified as under 40mm does not exceed 10 per cent of that dimension.
3. Any variation in a dimension as to the height of a letter specified in any of those diagrams shall be treated as permitted for the purposes of this Schedule if the variation—
 - (a) in the case of a dimension so specified as 105mm does not exceed 2.5 per cent of that dimension; or
 - (b) in the case of a dimension so specified as 70mm does not exceed 5 per cent of that dimension.
4. Any variation in a dimension as to the angle of hatching specified in any of those diagrams shall be treated as permitted for the purposes of this Schedule if the variation does not exceed 5 degrees.
5. A rear marking of a type shown in diagrams 1 or 4 above shall be constructed in the form of a single plate, and every rear marking shown in diagrams 2, 3 or 5 above shall be constructed in the form of two plates of equal size and shape.
6. The height of each half of the marking shown in diagram 3 above may be reduced to a minimum of 140mm provided the width is increased so that each half of the marking has a minimum area of 980cm².
7. All letters incorporated in a rear marking of a type shown in diagrams 4 or 5 above shall have the proportions and form of letters as shown in Part II of Schedule 13 of the Traffic Signs Regulations 1994(2).

Status: This is the original version (as it was originally made). This item of legislation is currently only available in its original format.

PART IV

REAR MARKINGS PRESCRIBED FOR MOTOR VEHICLES WHENEVER FIRST USED AND TRAILERS WHENEVER MANUFACTURED

MANUFACTURED

Left

Right

Diagram 1.



Diagram 2.



Diagram 3.



Diagram 4.

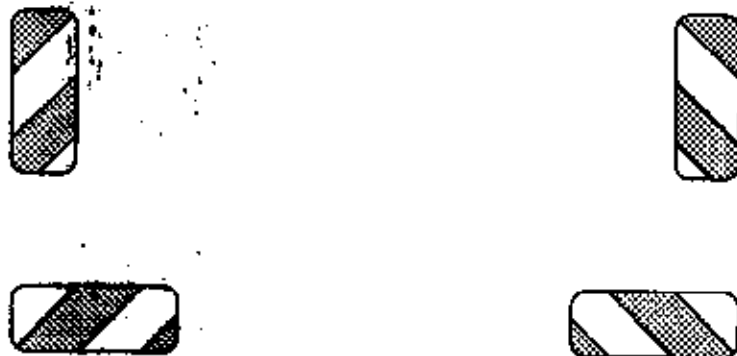

Status: This is the original version (as it was originally made). This item of legislation is currently only available in its original format.

PART IV—continued

Left

Right

Diagram 5.



Diagram 6.



Diagram 7.



Diagram 8.

