

## SCHEDULE 7

(Regulations 18 and 20)

### PART I

#### REQUIREMENTS RELATING TO OBLIGATORY DIRECTION INDICATORS AND TO OPTIONAL DIRECTION INDICATORS TO THE EXTENT SPECIFIED IN PART II

---

<b>1. Number (on each side of a vehicle)–</b>	One front indicator (Category 1, 1a or 1b), one rear indicator (Category 2, 2a or 2b) and one side repeater indicator [ <sup>F1</sup> (Category 5 or 6)] or, in the case of a motor vehicle having a maximum speed not exceeding 25 mph, one front indicator (Category 1, 1a or 1b) and one rear indicator (Category 2, 2a or 2b).
(a) A motor vehicle with three or more wheels, not being a motor bicycle combination, first used on or after 1st April 1986:	
(b) A trailer manufactured on or after 1st October 1985 drawn by a motor vehicle:	One rear indicator (Category 2, 2a or 2b) or, in the case of a trailer towed by a solo motor bicycle or a motor bicycle combination, one rear indicator (Category 12).
(c) A solo motor bicycle and a motor bicycle combination, in each case first used on or after 1st April 1986:	One front indicator (Category 1, 1a, 1b or 11) and one rear indicator (Category 2, 2a, 2b or 12).
(d) A motor vehicle first used on or after [ <sup>F2</sup> 1st April 1936] and before 1st April 1986, a trailer manufactured on or after [ <sup>F2</sup> 1st April 1936] and before 1st October 1985, a pedal cycle with or without a sidecar or a trailer, a horse-drawn vehicle and a vehicle drawn or propelled by hand:	Any arrangement of indicators so as to satisfy the requirements for angles of visibility in paragraph 3.
(e) A motor vehicle first used before 1st April 1936 and any trailer manufactured before that date:	Any arrangement of indicators so as to make the intention of the driver clear to other road users.
<b>2. Position–</b>	Within 2600 mm of the front of the vehicle
(a) Longitudinal–	
(i) A side repeater indicator which is required to be fitted in accordance with paragraph 1(a):	
(ii) (ii) Any other indicator:	No requirement
(b) Lateral–	400 mm
(i) Maximum distance from the side of the vehicle–	
(A) Any vehicle not covered by sub-paragraph (B):	
(B) A motor vehicle first used before 1st April 1986, a trailer manufactured before 1st October 1985, a solo motor bicycle, a	No requirement

*Changes to legislation: There are currently no known outstanding effects for the The Road Vehicles Lighting Regulations 1989, SCHEDULE 7. (See end of Document for details)*

pedal cycle, a horse-drawn vehicle and a vehicle drawn or propelled by hand:

- (ii) (ii) Minimum separation distance 500 mm or, if the overall width of the vehicle is between indicators on opposite sides less than 1400 mm, 400 mm of a vehicle—
  - (A) A motor vehicle (other than a solo motor bicycle or a motor bicycle combination or an invalid carriage having a maximum speed not exceeding 8 mph) first used on or after 1st April 1986, a trailer manufactured on or after 1st October 1985, a horse-drawn vehicle, a pedestrian-controlled vehicle and a vehicle drawn or propelled by hand:
    - (B) A solo motor bicycle having an engine exceeding 50 cc and first used on or after 1st April 1986—
      - (1) Front indicators: 300 mm
      - (2) Rear indicators: 240 mm
    - (C) A solo motor bicycle having an engine not exceeding 50 cc and first used on or after 1st April 1986 and a pedal cycle—
      - (1) Front indicators: 240 mm
      - (2) Rear indicators: 180 mm
    - (D) A motor bicycle combination first used on or after 1st April 1986: 400 mm
    - (E) An invalid carriage having a maximum speed not exceeding 8 mph—
      - (1) Front indicators: 240 mm
      - (2) Rear indicators: 300 mm
    - (F) A motor vehicle first used before 1st April 1986 and a trailer manufactured before 1st October 1985: No requirement
- (iii) (iii) Minimum separation distance between a front indicator and any dipped-beam headlamp or front fog lamp—
  - (a) in the case of a Category 1 indicator, 40 mm;
  - (b) in the case of a Category 1a indicator, 20 mm;
  - (c) in the case of a Category 1b indicator, no requirement
  - (A) Fitted to a motor vehicle, other than a solo motor bicycle or a motor bicycle combination, first used on or after [<sup>F3</sup>1st April 1995]:

- (B) Fitted to a solo motor bicycle or a motor bicycle combination in either case first used on or after 1st April 1986: 100 mm
- (C) Fitted to any other vehicle: No requirement
- (c) Vertical— 1500 mm or, if the structure of the vehicle makes this impracticable, 2300 mm.
- (i) Maximum height above the ground—
- (A) Any vehicle not covered by sub-paragraph (B) or (C):
- (B) A motor vehicle first used before 1st April 1986 and a trailer manufactured before 1st October 1985: No requirement
- (C) A motor vehicle having a maximum speed not exceeding 25 mph: No requirement
- (ii) (ii) Minimum height above the ground: 350 mm
- 3. Angles of visibility—** 80° outwards and 45° inwards
- (a) A motor vehicle first used on or after 1st April 1986 and a trailer manufactured on or after 1st October 1985—
- (i) Horizontal (see diagrams in Part III of this Schedule)—
- (A) A front or rear indicator fitted to a motor vehicle, other than a solo motor bicycle or a motor bicycle combination, having a maximum speed exceeding 25 mph and every rear indicator fitted to a trailer:
- (B) A front or rear indicator fitted to a solo motor bicycle or a motor bicycle combination: 80° outwards and 20° inwards
- (C) A front or rear indicator fitted to a motor vehicle, other than a solo motor bicycle or a motor bicycle combination, having a maximum speed not exceeding 25 mph: 80° outwards and 3° inwards
- (D) A side repeater indicator fitted to a motor vehicle or a trailer: Between rearward angles of 5° outboard and 60° outboard or, in the case of a motor vehicle having a maximum speed not exceeding 25 mph where it is impracticable to comply with the 5° angle, this may be replaced by 10°.
- (ii) (ii) Vertical— 15° above and below the horizontal
- (A) Except as provided by sub-paragraph [F<sup>4</sup>(B), (C) or (D)]:
- (B) Where the highest part of the illuminated area of the lamp is less than 1900 mm 15° above and 10° below the horizontal

**Changes to legislation:** There are currently no known outstanding effects for the *The Road Vehicles Lighting Regulations 1989, SCHEDULE 7.* (See end of Document for details)

above the ground and the vehicle is a motor vehicle having a maximum speed not exceeding 25 mph:	
(C) Where the highest part of the illuminated area of the lamp is less than 750 mm above the ground:	15° above and 5° below the horizontal
[ <sup>F5</sup> (D) But where the indicator is a category 6 indicator:	30° above and 5° below the horizontal]
(b) A motor vehicle first used before 1st April 1986, a trailer manufactured before 1st October 1985, a pedal cycle, a horse-drawn vehicle and a vehicle drawn or propelled by hand:	Such that at least one (but not necessarily the same) indicator on each side is plainly visible to the rear in the case of a trailer and both to the front and rear in the case of any other vehicle.
4. Alignment–	To the front
(a) A front indicator:	
(b) A rear indicator:	To the rear
(c) A side repeater indicator (Category 5 [ <sup>F6</sup> or 6]):	As shown in the first sketch in Part III of this Schedule
5. Markings–	An approval mark and, above such mark, the following numbers–
(a) A motor vehicle, other than a solo motor bicycle or a motor bicycle combination, first used on or after 1st April 1986 and a trailer, other than a trailer drawn by a solo motor bicycle or a motor bicycle combination, manufactured on or after 1st October 1985:	in the case of a front indicator, “1”, “1a” or “1b”; in the case of a rear indicator, “2”, “2a” or “2b”; in the case of a side repeater indicator, “5” [ <sup>F7</sup> or “6”].
(b) A solo motor bicycle and a motor bicycle combination in either case first used on or after 1st April 1986, a trailer, manufactured on or after 1st October 1985, drawn by such a solo motor bicycle or a motor bicycle combination, a pedal cycle, a horse-drawn vehicle and a vehicle drawn or propelled by hand:	An approval mark and, above such mark, the following numbers– in the case of a front indicator, “1”, “1a”, “1b” or “11”; in the case of a rear indicator, “2”, “2a”, “2b” or “12”; in the case of a side repeater indicator, “5”.
(c) A motor vehicle first used before 1st April 1986 and a trailer manufactured before 1st October 1985:	No requirement
6. Size of illuminated area:	No requirement
7. Colour–	Amber
(a) Any vehicle not covered by sub-paragraph (b):	
(b) An indicator fitted to a motor vehicle first used before 1st September 1965 and any trailer drawn thereby–	White or amber
(i) if it shows only the front:	
(ii) (ii) if it shows only the rear:	Red or amber

- (iii) (iii) if it shows both to the front and Amber  
to the rear:

**8. Wattage–** 15 to 36 watts

(a) Any front or rear indicator which emits  
a flashing light and does not bear an approval  
mark:

(b) Any other indicator: No requirement

**9. Intensity–** No requirement

(a) An indicator bearing an approval mark:

(b) An indicator not bearing an approval mark: Such that the light is plainly visible from a  
reasonable distance

#### Textual Amendments

- F1** Words in Sch. 7 Pt. 1 para. 1(a) substituted (4.1.2010) by [The Road Vehicles Lighting and Goods Vehicles \(Plating and Testing\) \(Amendment\) Regulations 2009 \(S.I. 2009/3220\)](#), regs. 1, **11(2)(a)**
- F2** Words in Sch. 7 Pt. 1 para. 1(d) substituted (1.10.1994) by [The Road Vehicles Lighting \(Amendment\) Regulations 1994 \(S.I. 1994/2280\)](#), regs. 1(2), **17(5)**
- F3** Words in Sch. 7 Pt. 1 para. 2(b)(iii)(A) substituted (1.10.1994) by [The Road Vehicles Lighting \(Amendment\) Regulations 1994 \(S.I. 1994/2280\)](#), regs. 1(2), **13**
- F4** Words in Sch. 7 Pt. 1 para. 3(a)(ii)(A) substituted (4.1.2010) by [The Road Vehicles Lighting and Goods Vehicles \(Plating and Testing\) \(Amendment\) Regulations 2009 \(S.I. 2009/3220\)](#), regs. 1, **11(2)(b)**
- F5** Sch. 7 Pt. 1 para. 3(a)(ii)(D) inserted (4.1.2010) by [The Road Vehicles Lighting and Goods Vehicles \(Plating and Testing\) \(Amendment\) Regulations 2009 \(S.I. 2009/3220\)](#), regs. 1, **11(2)(c)**
- F6** Words in Sch. 7 Pt. 1 para. 4(c) inserted (4.1.2010) by [The Road Vehicles Lighting and Goods Vehicles \(Plating and Testing\) \(Amendment\) Regulations 2009 \(S.I. 2009/3220\)](#), regs. 1, **11(2)(d)**
- F7** Words in Sch. 7 Pt. 1 para. 5(a) inserted (4.1.2010) by [The Road Vehicles Lighting and Goods Vehicles \(Plating and Testing\) \(Amendment\) Regulations 2009 \(S.I. 2009/3220\)](#), regs. 1, **11(2)(e)**

#### Commencement Information

- I1** Sch. 7 Pt. I para. 1 in force at 1.11.1989, see [reg. 1\(1\)](#)
- I2** Sch. 7 Pt. I para. 2 in force at 1.11.1989, see [reg. 1\(1\)](#)
- I3** Sch. 7 Pt. I para. 3 in force at 1.11.1989, see [reg. 1\(1\)](#)
- I4** Sch. 7 Pt. I para. 4 in force at 1.11.1989, see [reg. 1\(1\)](#)
- I5** Sch. 7 Pt. I para. 5 in force at 1.11.1989, see [reg. 1\(1\)](#)
- I6** Sch. 7 Pt. I para. 6 in force at 1.11.1989, see [reg. 1\(1\)](#)
- I7** Sch. 7 Pt. I para. 7 in force at 1.11.1989, see [reg. 1\(1\)](#)
- I8** Sch. 7 Pt. I para. 8 in force at 1.11.1989, see [reg. 1\(1\)](#)
- I9** Sch. 7 Pt. I para. 9 in force at 1.11.1989, see [reg. 1\(1\)](#)

**10. Electrical connections–**

(a) All indicators on one side of a vehicle together with all indicators on that side of any trailer drawn by the vehicle, while so drawn, shall be operated by one switch.

(b) All indicators on one side of a vehicle or combination of vehicles showing a flashing light shall flash in phase, except that in the case of a solo motor bicycle, a motor bicycle combination and a pedal cycle, the front and rear direction indicators on one side of the vehicle may flash alternately.

*Changes to legislation: There are currently no known outstanding effects for the The Road Vehicles Lighting Regulations 1989, SCHEDULE 7. (See end of Document for details)*

**Commencement Information**

**I10** Sch. 7 Pt. I para. 10 in force at 1.11.1989, see [reg. 1\(1\)](#)

**11. Tell-tale—**

(a) One or more indicators on each side of a vehicle to which indicators are fitted shall be so designed and fitted that the driver when in his seat can readily be aware when it is in operation; or

(b) The vehicle shall be equipped with an operational tell-tale for front and rear indicators (including any rear indicator on the rearmost of any trailers drawn by the vehicle).

**Commencement Information**

**I11** Sch. 7 Pt. I para. 11 in force at 1.11.1989, see [reg. 1\(1\)](#)

**12. Other requirements—**

(a) Every indicator (other than a semaphore arm, that is an indicator in the form of an illuminated sign which when in operation temporarily alters the outline of the vehicle to the extent of at least 150 mm measured horizontally and is visible from both the front and rear of the vehicle) shall when in operation show a light which flashes constantly at the rate of not less than 60 nor more than 120 flashes per minute. However, in the event of a failure, other than a short-circuit of an indicator, any other indicator on the same side of the vehicle or combination of vehicles may continue to flash, but the rate may be less than 60 or more than 120 flashes per minute. Every indicator shall when in operation perform efficiently regardless of the speed of the vehicle.

(b) Where two front or rear direction indicators are fitted to a motor vehicle first used on or after 1st April 1986, and two rear direction indicators are fitted to a trailer manufactured on or after 1st October 1985, in each case they shall be fitted so as to form a pair.

<sup>F8</sup>(c) .....

**Textual Amendments**

**F8** Sch. 7 Pt. I para. 12(c) omitted (1.10.1994) by virtue of [The Road Vehicles Lighting \(Amendment\) Regulations 1994 \(S.I. 1994/2280\)](#), regs. 1(2), [16\(1\)](#)

**Commencement Information**

**I12** Sch. 7 Pt. I para. 12 in force at 1.11.1989, see [reg. 1\(1\)](#)

**13. Definitions—**

In this Schedule “approval mark” means either—

(a) a marking designated as an approval mark by regulation 5 of the Designation of Approval Marks Regulations and shown at item 9 of Schedule 4 to those Regulations; or

(b) a marking designated as an approval mark by regulation 4 of the Designation of Approval Marks Regulations and shown at item 6 or, in the case of a solo motor bicycle or a motor bicycle combination, a pedal cycle, a horse-drawn vehicle or a vehicle drawn or propelled by hand, at item 50 of Schedule 2 to those Regulations.

**Commencement Information**

**I13** Sch. 7 Pt. I para. 13 in force at 1.11.1989, see [reg. 1\(1\)](#)

## PART II

### REQUIREMENTS RELATING TO OPTIONAL DIRECTION INDICATORS

1. No vehicle shall be fitted with a total of more than one front indicator nor more than two rear indicators, on each side.

.....  
**Commencement Information**

**I14** Sch. 7 Pt. II para. 1 in force at 1.11.1989, see [reg. 1\(1\)](#)

2. Any number of side indicators may be fitted to the side (excluding the front and rear) of a vehicle.

.....  
**Commencement Information**

**I15** Sch. 7 Pt. II para. 2 in force at 1.11.1989, see [reg. 1\(1\)](#)

3. The only other requirements prescribed by these Regulations in respect of any which are fitted are those specified in paragraphs 5, 7, 8, 9, 10, 11, 12(a) and 12(b) of Part I.

.....  
**Commencement Information**

**I16** Sch. 7 Pt. II para. 3 in force at 1.11.1989, see [reg. 1\(1\)](#)

## <sup>F9</sup>PART III

.....  
**Textual Amendments**

**F9** Sch. 7 Pt. 3: words “or 6” inserted in first diagram after “Category 5” (4.1.2010) by [The Road Vehicles Lighting and Goods Vehicles \(Plating and Testing\) \(Amendment\) Regulations 2009 \(S.I. 2009/3220\)](#), regs. 1, **11(3)**

.....  
**Commencement Information**

**I17** Sch. 7 Pt. III in force at 1.11.1989, see [reg. 1\(1\)](#)

**Changes to legislation:** There are currently no known outstanding effects for the The Road Vehicles Lighting Regulations 1989, SCHEDULE 7. (See end of Document for details)

### PART III

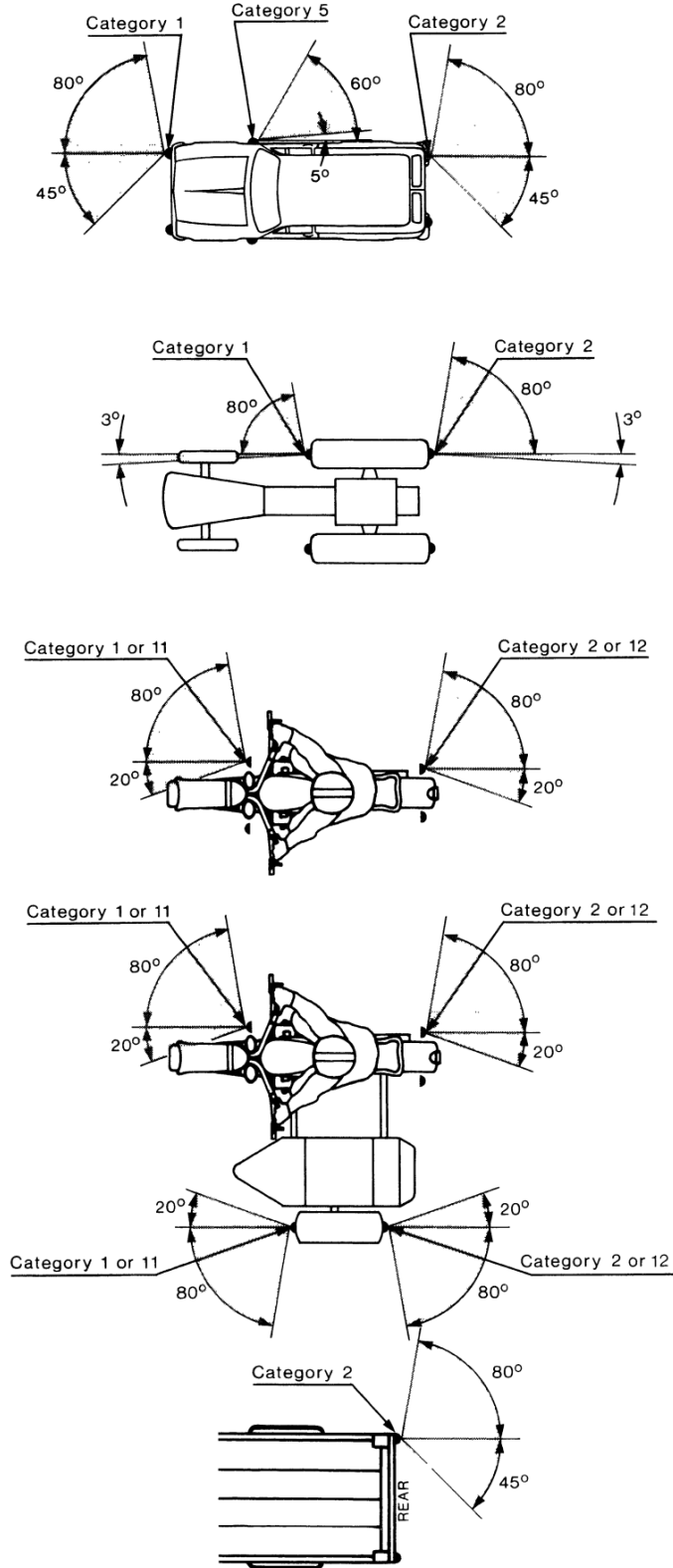



**Changes to legislation:**

There are currently no known outstanding effects for the The Road Vehicles Lighting Regulations 1989, SCHEDULE 7.