

SCHEDULE 13

Amendment of the Aerosol Dispensers Regulations 2009

Insertion of Schedule 1A

8. After the Schedule, insert—

“SCHEDULE 1A

Regulations 2 and 3

(Annex to the Directive)

1. DEFINITIONS

1.0. Regulation (EC) No 1272/2008

“Regulation (EC) No 1272/2008” means Regulation (EC) No 1272/2008 of the European Parliament and of the Council of 16 December 2008 on the classification, labelling and packaging of substances and mixtures, amending and repealing Directives 67/548/EEC and 1999/45/EC and amending Regulation (EC) No 1907/2006.

1.1. Pressures

“Pressures” means the internal pressures expressed in bars (relative pressures).

1.2. Test pressure

“Test pressure” means the pressure to which an unfilled aerosol dispenser container may be subjected for 25 seconds without any leakage being caused or, in the case of metal or plastic containers, any visible or permanent distortion except as allowed under 6.1.1.2.

1.3. Bursting pressure

“Bursting pressure” means the minimum pressure which causes the aerosol dispenser container to burst or rupture.

1.4. Total capacity of the container

“Total capacity of the container” means the volume in millilitres of an open container up to the rim of the opening.

1.5. Net capacity

“Net capacity” means the volume in millilitres of a filled and closed aerosol dispenser.

1.6. Volume of liquid phase

“Volume of liquid phase” means the volume of the non—gaseous phases in the filled and closed aerosol dispenser.

1.7. Test conditions

“Test conditions” means the values of test and bursting pressures exerted hydraulically at 20° C (\pm 5°C).

1.7a. Substance

“Substance” means substance as defined in Article 2(7) of Regulation (EC) No 1272/2008.

1.7b. Mixture

“Mixture” means mixture as defined in Article 2(8) of Regulation (EC) No 1272/2008.

1.8. Flammable contents

1.8. Contents of aerosols shall be considered as flammable if they contain any component which is classified as flammable:

- (a) flammable liquid means a liquid having a flashpoint of not more than 93°C.
- (b) flammable solid means a solid substance or mixture which is readily combustible or may cause or contribute to fire as a result of friction; readily combustible solids are powdered, granular, or pasty substances or mixtures which are dangerous if they can be easily ignited by brief contact with an ignition source, such as a burning match, and if the flame spreads rapidly.
- (c) flammable gas means a gas or gas mixture having a flammable range with air at 20°C and a standard pressure of 1.013 bar.

This definition does not cover pyrophoric, self—heating or water—reactive substances and mixtures, which shall never be components of aerosol contents.

1.9. Flammable aerosols

1.9. For the purpose of these Regulations, an aerosol is considered as “non—flammable”, “flammable” or “extremely flammable” according to its chemical heat of combustion and mass content of flammable components, as follows:

- (a) the aerosol is classified as “extremely flammable” if it contains 85% or more flammable components and the chemical heat of combustion exceeds or is equal to 30 kJ/g;
- (b) the aerosol is classified as “non—flammable” if it contains 1% or less flammable components and the chemical heat of combustion is less than 20 kJ/g;
- (c) all other aerosols will be submitted to the flammability classification procedures set out in 1.9.1. to 1.10. or shall be classified as “extremely flammable”. The ignition distance test, the enclosed space test and the foam flammability test shall comply with point 6.3.

1.9.1. Flammable spray aerosols

1.9.1. In the case of spray aerosols, the classification shall be made taking into account the chemical heat of combustion and on the basis of the results of the ignition distance test, as follows:

- (a) if the chemical heat of combustion is less than 20kJ/g:
 - (i) the aerosol is classified as “flammable” if ignition occurs at a distance equal or greater than 15 cm but less than 75 cm;
 - (ii) the aerosol is classified as “extremely flammable” if ignition occurs at a distance of 75 cm or more;
 - (iii) if no ignition occurs in the ignition distance test, the enclosed space test shall be performed and in this case, the aerosol is classified as “flammable” if the time equivalent is less than or equal to 300 s/m³ or the deflagration density is less than or equal to 300 g/m³; otherwise the aerosol is classified as “non—flammable”;

- (b) if the chemical heat of combustion is equal to or more than 20 kJ/g, the aerosol is classified as “extremely flammable” if ignition occurs at a distance of 75 cm or more; otherwise the aerosol is classified as “flammable”.

1.9.2. Flammable foam aerosols

1.9.2. In the case of foam aerosols, the classification shall be made on the basis of the results of the foam flammability test.

- (a) The aerosol product shall be classified as “extremely flammable” if:
 - (i) the flame height is 20 cm or more and the flame duration is two seconds or more;
 - or
 - (ii) the flame height is 4 cm or more and the flame duration is seven seconds or more.
- (b) The aerosol product which does not meet the criteria in (a) is classified as “flammable” if the flame height is 4 cm or more and the flame duration is two seconds or more.

1.10. Chemical Heat of Combustion

1.10. The chemical heat of combustion ΔH_c shall be either determined by:

- (a) acknowledged rules of technology, described e.g. in standards such as ASTM D 240, ISO 13943 86.1 to 86.3 and NFPA 30B, or found in the scientifically established literature; or
- (b) applying the following calculation method:

The chemical heat of combustion (ΔH_c), in kilojoules per gram (kJ/g), can be calculated as the product of the theoretical heat of combustion (ΔH_{comb}), and a combustion efficiency, usually less than 1,0 (a typical combustion efficiency is 0,95 or 95%).

For a composite aerosol formulation, the chemical heat of combustion is the summation of the weighted heats of combustion for the individual components, as follows:

$$\Delta H_c = \sum_i^n [w_i\% \times \Delta H_{c(i)}]$$

where:

ΔH_c = chemical heat of combustion (kJ/g) of the product;

$w_i\%$ = mass fraction of component i in the product;

$\Delta H_{c(i)}$ = specific heat of combustion (kJ/g) of component i in the product.

The person responsible for the marketing of the aerosol dispenser has to describe the method used for determining the chemical heat of combustion in a document to be made readily available in English at the address specified on the label in accordance with regulation 3(8)(a)(i), if the chemical heat of combustion is used as a parameter for assessing the flammability of aerosols, according to the provisions of these Regulations.

2. GENERAL PROVISIONS

2. Without prejudice to specific provisions of this Schedule on requirements related to the flammability and pressure hazard, the person responsible for the marketing of aerosol dispensers is under an obligation to analyse the hazards in order to identify those which apply to their aerosol dispensers. Where appropriate, this analysis shall include a consideration of the risks resulting from the inhalation of the spray ejected by the aerosol dispenser under normal and reasonably

foreseeable conditions of use, taking into account droplet size distribution in conjunction with physical and chemical properties of the contents. The person responsible for the marketing of the aerosol dispenser must then design, construct and test it and, if applicable, draft special statements concerning its use, taking account of this analysis.

2.1. Construction and equipment

2.1

2.1.1. The filled aerosol dispenser must be such that, under normal conditions of use and storage, it complies with the provisions of this Schedule.

2.1.2. The valve must enable the aerosol dispenser to be virtually hermetically sealed under normal conditions of storage or transport and must be protected, for example by means of a protective cap, against any unintentional opening and any deterioration.

2.1.3. There must be no possibility that the mechanical resistance of the aerosol dispenser can be impaired by the action of the substances contained in it, even during prolonged storage.

2.2. Labelling

2.2. Without prejudice to Regulation (EC) No 1272/2008, each aerosol dispenser must visibly bear the following and indelible marking:

- (a) where the aerosol is classified as “non—flammable” according to the criteria of point 1.9, the signal word “Warning” and the other label elements for Aerosols Category 3 provided for in Table 2.3.1 of Annex I to Regulation (EC) No 1272/2008;
- (b) where the aerosol is classified as “flammable” according to the criteria of point 1.9, the signal word “Warning” and the other label elements for Aerosols Category 2 provided for in Table 2.3.1 of Annex I to Regulation (EC) No 1272/2008;
- (c) where the aerosol is classified as “extremely flammable” according to the criteria of point 1.9, the signal word “Danger” and other label elements for Aerosols Category 1 provided for in Table 2.3.1 of Annex I to Regulation (EC) No 1272/2008;
- (d) where the aerosol dispenser is a consumer product, the precautionary statement P102 provided for in Part 1, Table 6.1 of Annex IV to Regulation (EC) No 1272/2008;
- (e) any additional operating precautions which alert consumers to the specific dangers of the product; if the aerosol dispenser is accompanied by separate instructions for use, the latter must also reflect such operating precautions.

2.3. Volume of the liquid phase

2.3. The volume of the liquid phase at 50°C must not exceed 90% of the net capacity.

3. SPECIAL PROVISIONS FOR METAL AEROSOL DISPENSERS

3

3.1. Capacity

3.1. The total capacity of these containers may not exceed 1000 ml.

3.1.1. Test pressure of the container

3.1.1

- (a) For containers filled at a pressure of less than 6.7 bars at 50°C, the test pressure must be equal to at least 10 bars.
- (b) For containers filled at a pressure equal to or greater than 6.7 bars at 50°C, the test pressure must be 50% higher than the internal pressure at 50° C.

3.1.2. The pressure at 50°C in the aerosol dispenser must not exceed the values provided for in the following table, depending upon the content of gases in the aerosol dispenser:

<i>Content of gases</i>	<i>Pressure at 50°C</i>
Liquified gas or mixture of gases having a flammable range with air at 20°C and a standard pressure of 1,013 bar	12 bar
Liquified gas or mixture of gases not having a flammable range with air at 20°C and a standard pressure of 1,013 bar	13.2 bar
Compressed gases or gases dissolved under pressure not having a flammable range with air at 20°C and a standard pressure of 1.013 bar	15 bar

4. SPECIAL PROVISIONS FOR GLASS AEROSOL DISPENSERS

4

4.1. Plastic coated or permanently protected containers

4.1. Containers of this type may be used for filling with compressed, liquefied or dissolved gas.

4.1.1. Capacity

4.1.1. The total capacity of these containers may not exceed 220 ml.

4.1.2. Coating

4.1.2. The coating must be a protective envelope of plastic or other suitable material, intended to prevent the risk of flying particles of glass if the container is accidentally broken, and must be so designed that there are no flying particles of glass if the filled aerosol dispenser, brought to a temperature of 20° C, is dropped from a height of 1.8 m onto a concrete floor.

4.1.3. Test pressure of the container

4.1.3

- (a) Containers used for filling with compressed or dissolved gas must resist a test pressure equal to at least 12 bars.
- (b) Containers used for filling with liquefied gas must resist a test pressure equal to at least 10 bars.

4.1.4. Filling

4.1.4

Draft Legislation: This is a draft item of legislation and has not yet been made as a UK Statutory Instrument. This draft has been replaced by a new draft, *The Product Safety and Metrology etc. (Amendment etc.) (EU Exit) Regulations 2019* ISBN 978-0-11-118040-2

- (a) Aerosol dispensers filled with compressed gas shall not be required to withstand a pressure of more than 9 bars at 50°C.
- (b) Aerosol dispensers filled with dissolved gas shall not be required to withstand a pressure of more than 8 bars at 50°C.
- (c) Aerosol dispensers containing liquefied gas or mixtures of liquefied gas shall not be required to withstand, at 20°C, pressures higher than those shown in the following table:

Total capacity	Percentage by weight of liquefied gas in the total mixture		
	20 %	50 %	80 %
50 to 80 ml	3.5 bars	2.8 bars	2.5 bars
< 80 to 160 ml	3.2 bars	2.5 bars	2.2 bars
< 160 to 220 ml	2.8 bars	2.1 bars	1.8 bars

This table shows the pressure limits permitted at 20°C in relation to the percentage of gas. Pressure limits for percentages of gas not shown in the table shall be extrapolated from it.

4.2. Unprotected glass containers

4.2. Aerosol dispensers using unprotected glass containers shall be filled exclusively with liquefied or dissolved gases.

4.2.1. Capacity

4.2.1. The total capacity of these containers may not exceed 150ml.

4.2.2. Test pressure of the container

4.2.2. The test pressure of the container must be equal to at least 12 bars.

4.2.3. Filling

4.2.3

- (a) Aerosol dispensers filled with dissolved gas shall not be required to withstand a pressure of more than 8 bars at 50°C.
- (b) Aerosol dispensers containing liquefied gas shall not be required to withstand, at 20° C, pressures in excess of those shown in the following table:

Total capacity	Percentage by weight of liquefied gas in the total mixture		
	20 %	50%	80%
50 to 70 ml	1.5 bar	1.5 bar	1.25 bar
< 70 to 150 ml	1.5 bar	1.5 bar	1 bar

This table shows the pressure limits permitted at 20°C in relation to the percentage of liquefied gas.

Pressure limits for percentages of gas not shown in the table shall be extrapolated from it.

5. SPECIAL PROVISIONS APPLYING TO PLASTIC AEROSOL DISPENSERS

5

5.1. Plastic aerosol dispensers which may splinter on bursting shall be treated in the same way as unprotected glass aerosol dispensers.

5.2. Plastic aerosol dispensers which cannot splinter on bursting shall be treated in the same way as glass aerosol dispensers with a protective coating.

6. TESTS

6

6.1. Test requirements to be guaranteed by the person responsible for marketing the aerosol dispenser

6.1

6.1.1.. Hydraulic test on empty containers

6.1.1.

6.1.1.1. Metal, glass or plastic aerosol dispensers must be able to withstand a hydraulic pressure test as laid down in 3.1.1, 4.1.3 and 4.2.2.

6.1.1.2. Metal containers showing assymetrical or major distortions or other similar faults shall be rejected. A slight symmetrical distortion of the base or one affecting the profile of the upper casing shall be allowed provided that the container passes the bursting test.

6.1.2. Bursting test for empty metal containers

6.1.2. The person responsible for marketing the aerosol dispenser must ensure that the bursting pressure of containers is at least 20% higher than the test pressure laid down.

6.1.3. Dropping test for protected glass containers

6.1.3. The manufacturer must ensure that the containers satisfy the test requirements laid down in 4.1.2.

6.1.4. Final inspection of filled aerosol dispensers

6.1.4

6.1.4.1. Aerosol dispensers shall be subject to one of the following final test methods.

(a) Hot water bath test

Each filled aerosol dispenser shall be immersed in a hot water bath.

(i) The temperature of the water bath and the duration of the test shall be such that the internal pressure reaches that which would be exerted by its contents at a uniform temperature of 50°C.

(ii) Any aerosol dispenser showing visible permanent distortion or a leak must be rejected.

(b) Hot final test methods

Other methods for heating the contents of aerosol dispensers may be used if they guarantee that the pressure and temperature in each filled aerosol dispenser reach the

values required for the hot water bath test and distortions and leaks are detected with same precision as in the case of the hot water bath test.

(c) Cold final test methods

An alternative cold final test method may be used if it is in accordance with the provisions of an alternative method to the hot water bath test for aerosol dispensers in paragraph 6.2.6.3.2 of Chapter 6.2 of Part 6 of Annex A to the European Agreement on the international carriage of dangerous goods by road⁽¹⁾.

6.1.4.2. For aerosol dispensers the contents of which undergo a physical or chemical transformation changing their pressure characteristics after filling and before first use, cold final test methods according to point 6.1.4.1(c) should be applied.

6.1.4.3. In case of test methods according to points 6.1.4.1(b) and 6.1.4.1(c):

- (a) the test method must be approved by the Secretary of State;
- (b) the person responsible for the marketing of aerosol dispensers must submit an application for approval to the Secretary of State. The application must be accompanied by the technical file describing the method;
- (c) the person responsible for the marketing of aerosol dispensers must, for surveillance purposes, keep the approval of the Secretary of State, the technical file describing the method and, if applicable, control reports readily available at the address specified on the label in accordance with regulation 3(8)(a)(i); and
- (d) the technical file must be in English.

6.2. Examples of inspection tests which may be carried out

6.2

6.2.1. Test on unfilled containers

6.2.1. The test pressure shall be applied for 25 seconds on five containers selected at random from a homogeneous batch of 2500 unfilled containers, that is, manufactured from the same materials by the same continuous batch manufacturing process, or from a batch constituting one hour's production.

If any one of these containers does not pass the test, ten additional containers shall be drawn at random from the same batch and put through the same test.

If any one of these aerosol containers does not pass the test, the whole batch shall be unsuitable for use.

6.2.2. Tests on filled aerosol dispensers

6.2.2. Air and water—tightness inspection tests shall be carried out by immersing a representative number of filled aerosol dispensers in a bath of water. The temperature of the bath and the period of immersion must be such as to enable the contents of the aerosol dispenser to attain a uniform temperature of 50°C during the time required to ensure that there is no bursting or rupture.

Any batch of aerosol dispensers which does not pass these tests must be considered unsuitable for use.

(1) ECE/TRANS/257 2017.

6.3. Tests on the flammability of aerosols

6.3

6.3.1. Ignition distance test for spray aerosols

6.3.1

6.3.1.1. Introduction

6.3.1.1

6.3.1.1.1. This test standard describes the method to determine the ignition distance of an aerosol spray in order to assess the associated flame risk. The aerosol is sprayed in the direction of an ignition source at intervals of 15cm to observe if ignition and sustained combustion of the spray takes place. Ignition and sustained combustion is defined as when a stable flame is maintained for at least five seconds. The ignition source is defined as a gas burner with a blue, non—luminous flame 4—5cm in height.

6.3.1.1.2. This test is applicable to aerosol products with a spray distance of 15 cm or more. Aerosol products with a spray distance of less than 15 cm such as dispensing foams, mousses, gels and pastes or fitted with a metering valve, are excluded from this test. Aerosol products that dispense foams, mousses, gels or pastes are subject to testing under the aerosol foam flammability test.

6.3.1.2. Apparatus and material

6.3.1.2

6.3.1.2.1. The following apparatus is required:

Water bath maintained at 20°C	accurate to $\pm 1^\circ\text{C}$
Calibrated laboratory scales (balance)	accurate to $\pm 0.1\text{ g}$
Chronometer (stopwatch)	accurate to $\pm 0.2\text{ s}$
Graduated scale, support and clamp	graduations in cm
Gas burner with support and clamp	
Thermometer	accurate to $\pm 1^\circ\text{C}$
Hygrometer	accurate to $\pm 5\%$
Pressure gauge	accurate to $\pm 0.1\text{ bar}$

6.3.1.3. Procedure

6.3.1.3

6.3.1.3.1. General requirements

6.3.1.3.1

6.3.1.3.1.1. Before testing, each aerosol dispenser shall be conditioned and then primed by discharging for approximately one second. The purpose of this action is to remove non—homogeneous material from the diptube.

6.3.1.3.1.2. The instructions of use shall be strictly followed, including whether the dispenser is intended to be used in the upright or inverted position. When shaking is required, shake immediately before testing.

6.3.1.3.1.3. The test shall be carried out in a draught—free environment capable of ventilation, with the temperature controlled at $20^{\circ}\text{C} \pm 5^{\circ}\text{C}$ and relative humidity in the range 30—80%.

6.3.1.3.1.4. Each aerosol dispenser is to be tested:

- (a) when full according to the complete procedure, with the gas burner in the range of 15—90cm distance from the actuator of the aerosol can;
- (b) when 10—12% full nominal (% by mass) only one test, either at 15cm distance from the actuator when the spray from a full can did not ignite at all, or at the flame ignition distance of the spray of a full can plus 15cm.

6.3.1.3.1.5. During the test, the can shall be positioned as indicated by label instructions. The ignition source shall be positioned accordingly.

6.3.1.3.1.6. The following procedure requires testing the spray at intervals of 15cm between the burner flame and the aerosol actuator, in the range of 15—90cm. It is efficient to start at 60cm distance between burner flame and aerosol actuator. The distance between burner flame and aerosol actuator shall be increased by 15cm in the case of an ignition of the spray at 60cm distance. The distance shall be decreased by 15cm in the case of no ignition at 60cm distance between burner flame and aerosol actuator. The aim of the procedure is to determine the maximum distance between aerosol actuator and burner flame that leads to sustained combustion of the spray or to determine that ignition could not be obtained at 15cm distance between the burner flame and the aerosol's actuator.

6.3.1.3.2. Test procedure

- (a) a minimum of 3 full aerosol dispensers per product shall be conditioned to $20^{\circ}\text{C} \pm 1^{\circ}\text{C}$ with at least 95 % of the dispenser immersed in the water for at least 30 minutes before each test (if the aerosol is fully immersed, 30 minutes conditioning is sufficient);
- (b) comply with general requirements; record the temperature and relative humidity of the environment;
- (c) weigh an aerosol dispenser and note its mass;
- (d) determine the internal pressure and initial discharge rate at $20^{\circ}\text{C} \pm 1^{\circ}\text{C}$ (to eliminate faulty or partly filled aerosol dispensers);
- (e) support the gas burner on a flat horizontal surface or fix the burner to a support by means of a clamp;
- (f) ignite the gas burner; the flame shall be non—luminous and approximately 4—5cm high;
- (g) place the actuator's exit orifice at the required distance from the flame; the aerosol shall be tested in the position it is designed to be used, e.g. upright or inverted;
- (h) level the actuator's orifice and burner flame, ensuring that the orifice is properly directed towards and aligned with the flame (see Figure below); the spray shall be expelled through the top half of the flame;

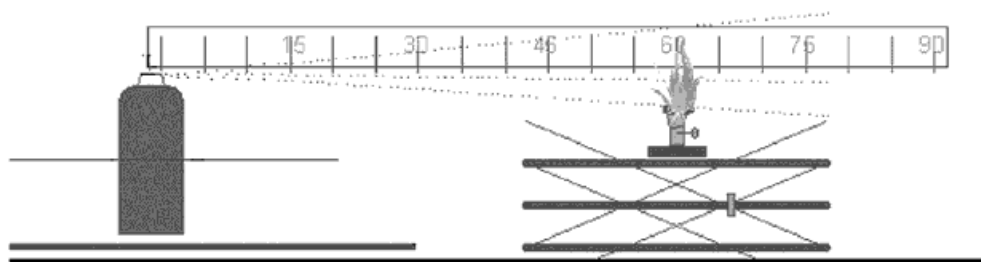

- (i) comply with the general requirements regarding shaking of the dispenser;
- (j) actuate the valve of the aerosol dispenser, to discharge its contents for five seconds, unless ignition occurs; if ignition occurs, continue discharging and time the duration of the flame for five seconds, from the start of ignition;
- (k) note the ignition results for the distance between the gas burner and the aerosol dispenser in the table provided;
- (l) if no ignition occurs during step (j), the aerosol shall be tested in alternative orientations, e.g. inverted for upright use products, to check if ignition is obtained;
- (m) repeat steps (g) to (l) twice more (a total of 3) for the same can at the same distance between the gas burner and the aerosol actuator;
- (n) repeat the test procedure for another two aerosol cans of the same product at the same distance between gas burner and aerosol actuator;
- (o) repeat steps (g) to (n) of the test procedure at a distance between 15 and 90 cm between the actuator of the aerosol can and the burner flame depending on the outcome of each test (see also 6.3.1.3.1.4 and 6.3.1.3.1.5);
- (p) if no ignition occurs at 15cm, the procedure is finished for initially full cans; the procedure is also finished when ignition and sustained combustion is obtained at a distance of 90cm; if ignition could not be obtained at 15cm distance, record that ignition did not occur; the maximum distance between burner flame and the aerosol's actuator for which an ignition and sustained combustion was observed is noted as the "ignition distance", in all other circumstances;
- (q) one test shall also be conducted on three cans of 10—12% nominal fill level; these cans shall be tested at a distance between the aerosol's actuator and the burner flame of the "flame ignition distance of full cans + 15cm";
- (r) discharge an aerosol can to a 10—12% nominal fill level (by mass) in bursts of 30 seconds maximum; observe a 300 seconds minimum time period between bursts; during this interim period dispensers shall be placed in the water bath for conditioning;
- (s) repeat steps (g) to (n) for 10—12% nominal fill aerosol cans, omitting steps (l) and (m); this test shall only be performed with the aerosol in one position, e.g. upright or inverted, corresponding with that which produced the ignition (if any) for filled cans;
- (t) record all results in the Table 6.3.1.1 as shown below.

6.3.1.3.2.1. All experiments shall be performed in a fume hood in a room that may be well ventilated. Ventilation of the fume hood and room can be applied for at least three minutes after each test. Take all necessary safety precautions to prevent the inhalation of combustion products.

6.3.1.3.2.2. The cans with a 10—12 % nominal fill level shall be tested only once. The result tables need only one result per can indicated.

Draft Legislation: This is a draft item of legislation and has not yet been made as a UK Statutory Instrument. This draft has been replaced by a new draft, *The Product Safety and Metrology etc. (Amendment etc.) (EU Exit) Regulations 2019* ISBN 978-0-11-118040-2

6.3.1.3.2.3. When the test in the position in which the dispenser is designed to be used gives a negative result, the test shall be repeated in the position of the dispenser most likely to result in a positive result.

6.3.1.4. Method of assessing results

6.3.1.4

6.3.1.4.1. All the results shall be recorded. Table 6.3.1.1 below shows the model of “result table” to be used.

Table 6.3.1.1

<i>Date</i>		<i>Temperature ... °C Relative humidity ... %</i>								
Name of product										
Net volume		Can 1			Can 2			Can 3		
Initial level of filling		%			%			%		
Dispenser distance	Test	1	2	3	1	2	3	1	2	3
15 cm	Ignition? Y or N									
30 cm	Ignition? Y or N									
45 cm	Ignition? Y or N									
60 cm	Ignition? Y or N									
75 cm	Ignition? Y or N									
90 cm	Ignition? Y or N									
Observations — including can position										

6.3.2. Enclosed space ignition test

6.3.2

6.3.2.1. Introduction

6.3.2.1. This test standard describes the method to assess the flammability of products emerging from aerosol dispensers due to their propensity to ignite in an enclosed or confined

space. The contents of an aerosol dispenser are sprayed into a cylindrical test vessel containing a burning candle. If an observable ignition occurs, the elapsed time and amount discharged is noted.

6.3.2.2. Apparatus and material

6.3.2.2

6.3.2.2.1. The following apparatus is required:

Chronometer (stopwatch)	accurate to $\pm 0,2$ s
Water bath maintained at 20 °C	accurate to ± 1 °C
Calibrated laboratory scales (balance)	accurate to $\pm 0,1$ g
Thermometer	accurate to ± 1 °C
Hygrometer	accurate to ± 5 %
Pressure gauge	accurate to ± 0.1 bar
Cylindrical test vessel	as detailed below

6.3.2.2.2. Preparation of test apparatus

6.3.2.2.2

6.3.2.2.2.1. A cylindrical vessel approximately 200 dm³ volume, approximately 600mm in diameter and approximately 720mm long and open at one end shall be modified as follows:

- (a) a closure system consisting of a hinged cover shall be matched to the open end of the receptacle; or
- (b) a plastic film 0.01 to 0.02 mm thick may be used as a closure system; if the test is carried out with a plastic film this must be used as described below: stretch the film over the open end of the drum and hold it in place with an elastic band; the strength of the band shall be such that when placed around the drum resting on its side, it stretches by only 25mm when a mass of 0.45 kg is attached to its lowest point; cut a 25 mm slit in the film, starting 50 mm from the edge of the drum. Ensure that the film is taut;
- (c) at the other end of the drum drill a 50mm diameter hole 100mm from the edge in such a way that the orifice is uppermost when the receptacle is laid down and ready for the test (Figure below);

Draft Legislation: This is a draft item of legislation and has not yet been made as a UK Statutory Instrument. This draft has been replaced by a new draft, The Product Safety and Metrology etc. (Amendment etc.) (EU Exit) Regulations 2019 ISBN 978-0-11-118040-2

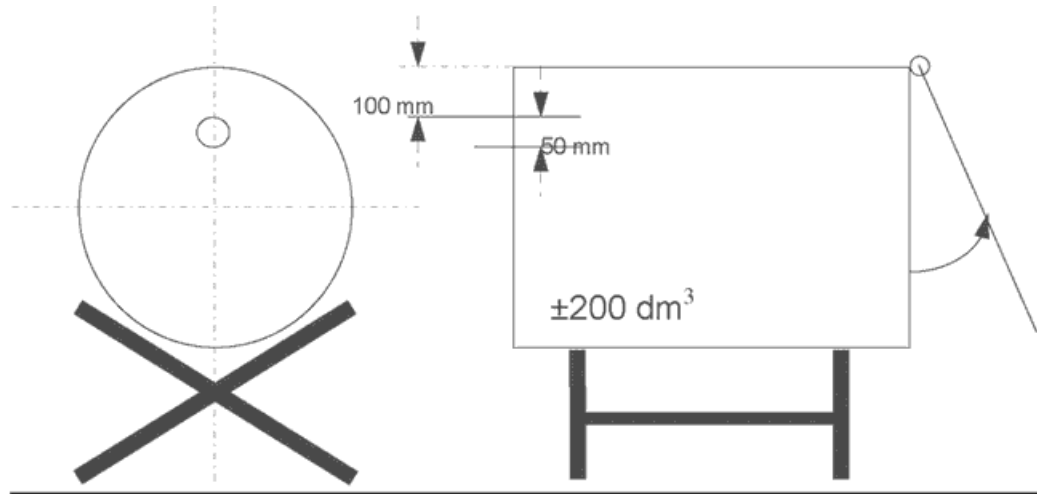

- (d) on a 200×200 mm metal support place a paraffin wax candle 20 to 40 mm in diameter and 100 mm high; the candle shall be replaced when having a height of less than 80 mm; the candle's flame is protected from the action of the spray by a 150 mm wide, 200 mm high deflector; this includes the plane inclined at 45° produced 150 mm from the base of the deflector (see Figure below);

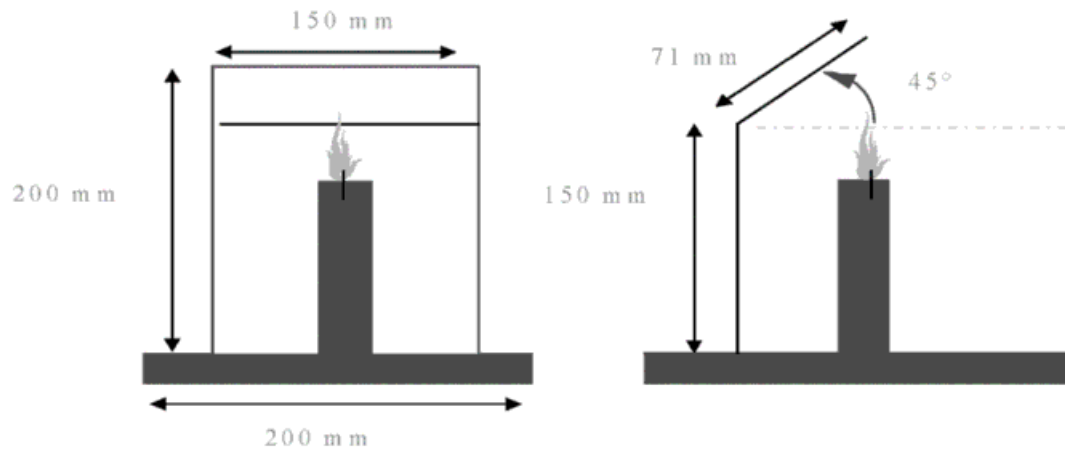

- (e) the candle placed on the metal support shall be positioned midway between the two ends of the drum (see Figure below);

- (c) comply with general requirements; record the temperature and relative humidity of the environment;
- (d) determine the internal pressure and initial discharge rate at $20\text{ }^{\circ}\text{C} \pm 1\text{ }^{\circ}\text{C}$ (to eliminate faulty or partly filled aerosol dispensers);
- (e) weigh one of the aerosol dispensers and note its mass;
- (f) light the candle and apply the closure system (cover or plastic film);
- (g) place the aerosol dispenser actuator orifice 35 mm or closer for a wide spray product, from the centre of the entrance hole in the drum; start the chronometer (stopwatch) and following the instructions for use of the product; direct the spray towards the centre of the opposite extremity (cover or plastic film); the aerosol shall be tested in the position it is designed to be used, e.g. upright or inverted;
- (h) spray until ignition occurs; stop the chronometer and note the time elapsed; re—weigh the aerosol dispenser and note its mass;
- (i) ventilate and clean the drum removing any residue likely to affect subsequent tests; allow the drum to cool if necessary;
- (j) repeat the test procedure steps (d) to (i) for another two aerosol dispensers of the same product (three in total, note: each dispenser is only tested once).

6.3.2.4. Method of assessing results

6.3.2.4

6.3.2.4.1. A test report containing the following information shall be drawn up:

- (a) the product tested and its references;
- (b) the internal pressure and discharge rate of the aerosol dispenser;
- (c) the temperature and relative air humidity of the room;
- (d) for each test, the discharge time (s) needed to achieve ignition (if the product does not ignite, state this);
- (e) the mass of the product sprayed during each test (in g);
- (f) the actual volume of the drum (in dm^3).

6.3.2.4.2. The time equivalent (t_{eq}) needed to achieve ignition in one cubic metre can be calculated as follows:

$$t_{\text{eq}} = \frac{1\ 000 \times \text{discharge time (s)}}{\text{Actual volume of drum (dm}^3\text{)}}$$

6.3.2.4.3. The deflagration density (D_{def}) needed to achieve ignition during the test may also be calculated as follows:

$$D_{\text{def}} = \frac{1\ 000 \times \text{Amount of product dispensed (g)}}{\text{Actual volume of drum (dm}^3\text{)}}$$

6.3.3. Aerosol foam flammability test

6.3.3

6.3.3.1. Introduction

6.3.3.1

6.3.3.1.1. This test standard describes the method to determine the flammability of an aerosol spray emitted in the form of a foam, mousse, gel or paste. An aerosol, which emits a foam, mousse, gel or paste is sprayed (approximately 5 g) on a watchglass and an ignition source (candle, wax taper, match or lighter) is placed at the base of the watchglass to observe if ignition and sustained combustion of the foam, mousse, gel or paste occurs. Ignition is defined as a stable flame maintained for at least two seconds and a minimum 4 cm in height.

6.3.3.2. Apparatus and material

6.3.3.2

6.3.3.2.1. The following apparatus is required:

Graduated scale, support and clamp	gradations in cm
Fire—resistant watchglass roughly 150 mm in diameter	
Chronometer (stopwatch)	accurate to $\pm 0,2$ s
Candle, wax taper, match or lighter	
Calibrated laboratory scales (balance)	accurate to $\pm 0,1$ g
Water bath maintained at 20°C	accurate to ± 1 °C
Thermometer	accurate to ± 1 °C
Hygrometer	accurate to ± 5 %
Pressure gauge	accurate to ± 0.1 bar

6.3.3.2.2. The watch—glass is placed on a fire—resistant surface within a draught—free area that may be ventilated after each test. The graduated scale is positioned exactly behind the watch—glass and held vertically by means of a support and clamp.

6.3.3.2.3. The scale is positioned in such a way that its origin is on a level with the watch—glass base in a horizontal plane.

6.3.3.3. Procedure

6.3.3.3

6.3.3.3.1. General requirements

6.3.3.3.1

6.3.3.3.1.1. Before testing, each aerosol dispenser shall be conditioned and then primed by discharging for approximately 1 second. The purpose of this action is to remove non—homogeneous material from the diptube.

6.3.3.3.1.2. The instructions of use shall be strictly followed, including whether the dispenser is intended to be used in the upright or inverted position. When shaking is required, shake immediately before testing.

6.3.3.3.1.3. The tests shall be carried out in a draught—free environment capable of ventilation, with the temperature controlled at $20^{\circ}\text{C} \pm 5^{\circ}\text{C}$ and relative humidity in the range of 30—80%.

6.3.3.3.2. Test procedure

6.3.3.3.2

- (a) a minimum of four full aerosol dispensers per product shall be conditioned to $20\text{ }^{\circ}\text{C} \pm 1\text{ }^{\circ}\text{C}$ with at least 95% of the dispenser immersed in the water for at least 30 min before each test (if the aerosol is fully immersed, 30 minutes conditioning is sufficient);
- (b) comply with general requirements. Record the temperature and relative humidity of the environment;
- (c) determine the internal pressure at $20\text{ }^{\circ}\text{C} \pm 1\text{ }^{\circ}\text{C}$ (to eliminate faulty or partly filled aerosol dispensers);
- (d) measure the discharge or flow rate of the aerosol product to be examined, so that the amount of test product dispensed can be more accurately gauged;
- (e) weigh one of the aerosol dispensers and note its mass;
- (f) on the basis of the measured discharge or flow rate and following the manufacturer's instructions, release approximately 5 g of the product onto the centre of the clean watch glass with the aim of producing a mound no higher than 25 mm;
- (g) within five seconds of completion of discharge, apply the source of ignition to the edge of the sample at its base and at the same time start the chronometer (stopwatch); if necessary, the ignition source shall be removed from the edge of the sample after approximately two seconds, in order to clearly observe if ignition has occurred; if no ignition of the sample is apparent, the ignition source shall be reapplied to the edge of the sample;
- (h) if ignition occurs note the following points:
 - (i) the maximum height of the flame in cm above the base of the watch—glass;
 - (ii) the flame duration in s;
 - (iii) dry and re—weigh the aerosol dispenser and calculate the mass of the released product;
- (i) ventilate the test area immediately after each test;
- (j) if ignition is not obtained and the released product remains in the form of a foam or paste throughout its period of use, steps (e) to (i) shall be repeated; allow the product to stand for 30 seconds, 1 minute, 2 minutes or 4 minutes before applying the ignition source;
- (k) repeat the test procedure steps (e) to (j) twice more (a total of 3) for the same can;
- (l) repeat the test procedure steps (e) to (k) for another two aerosol cans (3 cans in total) of the same product.

6.3.3.4. Method of assessing results

6.3.3.4

6.3.3.4.1. A test report containing the following information shall be drawn up:

- (a) whether the product ignites;
- (b) the maximum flame height in cm;
- (c) the duration of flame in seconds;
- (d) the mass of the product tested.”.