

## 1992 No. 133

## ROAD TRAFFIC AND VEHICLES

Traffic Signs (Amendment) Regulations  
(Northern Ireland) 1992

*Made* . . . . . 16th March 1992

*Coming into operation* . . . . . 29th April 1992

The Department of the Environment, in exercise of the powers conferred on it by Articles 2(2) and 27 of the Road Traffic (Northern Ireland) Order 1981(a) and of every other power enabling it in that behalf, makes the following regulations:

*Citation and commencement*

1. These regulations may be cited as the Traffic Signs (Amendment) Regulations (Northern Ireland) 1992 and shall come into operation on 29th April 1992.

*Amendment*

2. Schedule 1 to the Traffic Signs Regulations (Northern Ireland) 1979(b) is amended by—

(a) in Part I (warning signs)—

- (i) substituting below diagram 547.5 for the words from “co-incident” to the end the words “located in accordance with regulation 3(2) of the Road Humps Regulations (Northern Ireland) 1992(c)”; and
- (ii) inserting after diagram 547.5 the following diagram 547.6 and the words in and under it—

---

(a) S.I. 1981/154 (N.I. 1). Art. 2(2) is cited because it contains a definition of “Department”.  
(b) S.R. 1979 No. 386. Relevant amending rules are S.R. 1985 No. 24 and S.R. 1990 No. 122.  
(c) S.R. 1992 No. 132

**(Black on White)**

Plate for use with sign in diagram 543 in a case where a road hump is located in accordance with regulation 3(4) of the Road Humps Regulations (Northern Ireland) 1992 within the limits of a Pelican crossing as indicated in accordance with regulation 3(2) and Schedule 2 to the (Pelican) Pedestrian Crossings Regulations (Northern Ireland) 1989(a).

**547.6**

- (b) in Part II (regulatory signs), inserting under diagram 618.1 after the words "Permitted variants:" the words " "Except for access" may be omitted or"
- (c) in Part III (markings on the road)—
  - (i) substituting for diagram 1060 and the words under it the following diagram and the words under it—

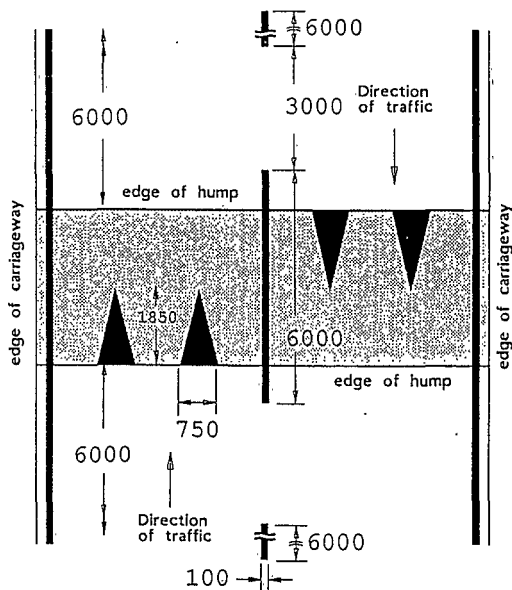

To indicate to vehicular traffic the presence of a round top road hump extending across the whole width of the carriageway.

Permitted variant:

the longitudinal line adjacent to the edge of the carriageway may be omitted when the longitudinal line in diagram 1017 or 1018 is placed in the position of that line.

**1060**

- (ii) adding after diagram 1060 the following diagrams 1060.1, 1061, and 1061.1 and the words under them—

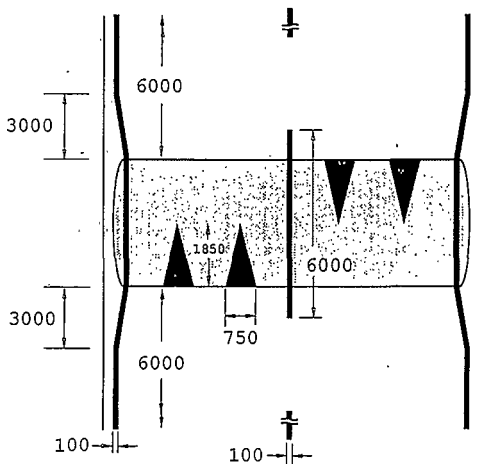

To indicate to vehicular traffic the presence of a round top road hump with tapered ends.

**1060.1**



Sealed with the Official Seal of the Department of the Environment on  
16th March 1992.

(L.S.)

E. J. Galway

Assistant Secretary

---

### EXPLANATORY NOTE

*(This note is not part of the Regulations.)*

These Regulations amend the Traffic Signs Regulations (Northern Ireland) 1979. The amendments—

- (a) insert a diagram illustrating a plate (“Humped Pelican Crossing”) to be used with the traffic sign shown in diagram 543 (traffic signals ahead) in a case where a road hump is located in accordance with the Road Humps Regulations (Northern Ireland) 1992 within the limits of a Pelican Crossing;
- (b) substitute for diagram 1060 a new diagram which illustrates a sign indicating a round top road hump extending across the whole width of a carriageway;
- (c) insert 3 new diagrams to illustrate signs indicating humps as follows—
  - (i) diagram 1060.1 to indicate a round top road hump with tapered ends;
  - (ii) diagram 1061 to indicate a flat top road hump extending across the whole width of a carriageway; and
  - (iii) diagram 1061.1 to indicate a flat top road hump with tapered ends.
- (d) provide for an additional permitted variant for diagram 618.1.