

Commission Regulation (EU) 2019/1892 of 31 October 2019 amending Regulation (EU) No 1230/2012 as regards type-approval requirements for certain motor vehicles fitted with elongated cabs and for aerodynamic devices and equipment for motor vehicles and their trailers (Text with EEA relevance)

COMMISSION REGULATION (EU) 2019/1892

of 31 October 2019

amending Regulation (EU) No 1230/2012 as regards type-approval requirements for certain motor vehicles fitted with elongated cabs and for aerodynamic devices and equipment for motor vehicles and their trailers

(Text with EEA relevance)

THE EUROPEAN COMMISSION,

Having regard to the Treaty on the Functioning of the European Union,

Having regard to Regulation (EC) No 661/2009 of the European Parliament and of the Council of 13 July 2009 concerning type-approval requirements for the general safety of motor vehicles, their trailers and systems, components and separate technical units intended therefor<sup>(1)</sup>, and in particular Article 14(1)(a) thereof,

Whereas:

- (1) Commission Regulation (EU) No 1230/2012<sup>(2)</sup> implements Regulation (EC) No 661/2009 through laying down requirements for the EC type-approval of motor vehicles and their trailers with regard to their masses and dimensions.
- (2) Aerodynamic devices and equipment, such as for instance retractable or foldable flaps attached to the rear of trucks and their trailers, as well as aerodynamic devices and equipment for cabs are currently available technology with a potential for improving the aerodynamic performance of vehicles. However, due to their design, those devices and equipment may project beyond the outermost part at the front, back or laterally of the vehicles on which they are fitted. Therefore, vehicles fitted with such devices and equipment should be exempted from the requirements relating to the standard dimensions.
- (3) Council Directive 96/53/EC<sup>(3)</sup> was amended by Directive (EU) 2015/719 of the European Parliament and of the Council<sup>(4)</sup> and by Regulation (EU) 2019/1242 of the European Parliament and of the Council<sup>(5)</sup> to provide for a derogation from the maximum length and weight restrictions in order to allow the use of motor vehicles with improved aerodynamic characteristics and alternatively fuelled or zero-emission motor vehicles, respectively, in cross-border traffic.
- (4) With a view to ensuring coherence between EC type-approval legislation and the harmonised rules for road vehicles circulating within the Union, it is necessary to lay down type-approval requirements for motor vehicles with elongated cabs and for

aerodynamic equipment or devices in order to ensure that they provide benefits in terms of energy performance, better visibility for drivers, safety to other road users as well as safety and comfort for drivers.

- (5) It is not possible for an approval authority to certify that a type of aerodynamic device and equipment satisfies the relevant technical requirements independently of a vehicle. Such aerodynamic devices and equipment should therefore be type-approved in relation to one or more specified types of vehicles or in relation to generic vehicles for which the precise dimensions and material specifications at the installation location are defined. For that reason, they should be type-approved as separate technical units and the specific requirements for their approval before being placed on the market should be set out. Elongated cabs should be subject to a vehicle type-approval, respectively, as required by Directive 96/53/EC.
- (6) Compliance with the upcoming CO<sub>2</sub> emission standards for heavy duty vehicles will require the application of various technologies to improve energy efficiency. One of the most efficient measures to improve energy efficiency is to reduce air drag of motor vehicles.
- (7) Retractable or foldable aerodynamic devices attached to the rear of trucks and their trailers and aerodynamic devices and equipment of cabs should be constructed in such a way to ensure that they do not impair the capability of the vehicle to be used for intermodal transport. Therefore, the maximum width of 2,60 m should apply to all vehicles, including the refrigerated ones. In addition, the aerodynamic devices should be able to resist the displacement of air generated by operational circumstances in intermodal transport.
- (8) Alternatively fuelled or zero-emission motor vehicles should benefit from extra weight allowance. The additional weight required for the alternative fuel or zero-emission technology should be clearly indicated on the manufacturer's statutory plate.
- (9) Regulation (EU) No 1230/2012 should therefore be amended accordingly.
- (10) The measures provided for in this Regulation are in accordance with the opinion of the Technical Committee – Motor Vehicles,

HAS ADOPTED THIS REGULATION:

*Article 1*

Regulation (EU) No 1230/2012 is amended as follows:

- (1) in Article 1, paragraph 1 is replaced by the following:
  1. This Regulation lays down the requirements for the EC type-approval of motor vehicles and their trailers with regard to their masses and dimensions as well as of certain separate technical units intended for those vehicles.;
- (2) Article 2 is amended as follows:
  - (a) points (25) and (26) are replaced by the following:
    - (25) “wheelbase” means the following:

- (a) for motor vehicles and drawbar trailers, the horizontal distance between the centre of the first and the last axle;
    - (b) for centre-axle trailers, semi-trailers and rigid drawbar trailers, the distance between the vertical axis of the coupling and the centre of the last axle;
  - (26) “axle spacing” means the distance between two consecutive axles; for centre axle trailers, semi-trailers and rigid drawbar trailers, the first axle spacing is the horizontal distance between the vertical axis of the front coupling and the centre of the first axle;
  - (b) point (33) is replaced by the following:
    - (33) “rear swing-out” means the distance between the initial point and the actual extreme point reached by the rear end of a vehicle when manoeuvring in the conditions specified in Section 8 of Part B of Annex I or in Section 7 of Part C of that Annex;
  - (c) the following point (41) is added:
    - (41) “aerodynamic devices and equipment” mean devices or equipment that are designed to reduce the aerodynamic drag of road vehicles, with the exception of elongated cabs.;
- (3) the following Articles 4a and 4b are inserted:

*Article 4a*

**EC separate technical unit type-approval  
of aerodynamic devices and equipment**

- 1 The manufacturer or his representative shall submit to the type-approval authority the application for EC type-approval of an aerodynamic device or equipment as a separate technical unit.  
  
The application shall be drawn up in accordance with the model of the information document set out in Part C of Annex V.
- 2 If the relevant requirements set out in this Regulation are met, the approval authority shall grant an EC separate technical unit type-approval and issue a type-approval number in accordance with the numbering system set out in Annex VII to Directive 2007/46/EC  
  
A Member State shall not assign the same number to another type of separate technical unit.
- 3 For the purposes of paragraph 2, the type-approval authority shall deliver an EC type-approval certificate established in accordance with the model set out in Part D of Annex V.

*Article 4b*

**EC separate technical unit type-approval mark**

Every separate technical unit conforming to a type in respect of which EC separate technical unit type-approval has been granted pursuant to this Regulation shall bear an EC separate technical unit type-approval mark as set out in Part E of Annex V;

- (4) Annex I is amended in accordance with Annex I to this Regulation;
- (5) Annex V is amended in accordance with Annex II to this Regulation.

*Article 2*

This Regulation shall enter into force on the twentieth day following that of its publication in the *Official Journal of the European Union*.

This Regulation shall be binding in its entirety and directly applicable in all Member States.

Done at Brussels, 31 October 2019.

*For the Commission*

*The President*

Jean-Claude JUNCKER

## ANNEX I

Annex I to Regulation (EU) No 1230/2012 is amended as follows:

- (1) in Part A, point 1.3 is replaced by the following:
  - 1.3. The devices and equipment referred to in Appendix 1 shall not be taken into account for the determination of the length, width and height.;
- (2) Part B is amended as follows:
  - (a) point 1.3 is replaced by the following:
    - 1.3. The devices and equipment referred to in Appendix 1 shall not be taken into account for the determination of the length, width and height.;
  - (b) the following points 1.3.1. to 1.3.1.3. are inserted:
    - 1.3.1. Additional requirements for aerodynamic devices referred to in Appendix 1
      - 1.3.1.1. Aerodynamic devices and equipment not exceeding 500 mm in length in the in-use position shall not increase the overall usable cargo space. They shall be constructed in such a way as to make it possible to lock them in the retracted or folded and the in-use positions. Such devices and equipment shall furthermore be constructed so as to be retractable or foldable when the vehicle is at stand-still in such a way that the maximum authorised width of the vehicle referred to in point 1.1.2. is not exceeded by more than 25 mm on each side of the vehicle and the maximum authorised length of the vehicle referred to in point 1.1.1. is not exceeded by more than 200 mm as permitted only from a height above the ground of at least 1 050 mm so that they do not impair the capability of the vehicle to be used for intermodal transport. In addition, the requirements set out in points 1.3.1.1.1 and 1.3.1.1.3. shall be met.
        - 1.3.1.1.1. The devices and equipment shall be type-approved in accordance with this Regulation.
        - 1.3.1.1.2. It shall be possible for the operator to vary the position of the aerodynamic device and equipment, and to retract or fold it, by applying a manual force not exceeding 40 daN. In addition, this may be done automatically as well.
        - 1.3.1.1.3. It is not required for devices and equipment to be retractable or foldable if the maximum dimensional requirements are fully complied with under all conditions.
      - 1.3.1.2. Aerodynamic devices and equipment exceeding 500 mm in length in the in-use position shall not increase the overall usable cargo space. They shall be constructed in such a way as to make it possible to lock them in both the retracted or folded and the in-use positions. Such devices shall furthermore be constructed so as to be retractable or foldable when the vehicle is at stand-still in such a way that the maximum authorised width of the vehicle referred to in point 1.1.2. is not exceeded by more than 25 mm on each side

---

**Status:** This is the original version (as it was originally adopted).

---

of the vehicle and the maximum authorised length of the vehicle referred to in point 1.1.1. is not exceeded by more than 200 mm as permitted only from a height above the ground of at least 1 050 mm so that they do not impair the capability of the vehicle to be used for intermodal transport. In addition, the requirements set out in points 1.3.1.2.1. to 1.3.1.2.4. shall be met.

- 1.3.1.2.1. The devices and equipment shall be type-approved in accordance with this Regulation.
- 1.3.1.2.2. It shall be possible for the operator to vary the position of the aerodynamic device and equipment, and to retract or fold it, by applying a manual force not exceeding 40 daN. In addition, this may be done automatically as well.
- 1.3.1.2.3. Each main vertical element or combination of elements and main horizontal element or combination of elements forming the devices and equipment shall, when installed on the vehicle and in the in-use position, withstand vertical and horizontal traction and push forces, applied sequentially in up, down, left and right direction, of 200 daN  $\pm$  10 % applied statically to the geometric centre of the relevant perpendicular projected surface, at a maximum pressure of 2,0 MPa. The devices and equipment may deform, but the system for adjustment and locking shall not release as a result of the applied forces. The deformation shall be limited to ensure that the maximum authorised width of the vehicle is not exceeded by more than 25 mm on each side of the vehicle, during and after the test.
- 1.3.1.2.4. Each main vertical element or combination of elements and main horizontal element or combination of elements forming the devices and equipment shall also, when in the retracted or folded position, withstand a horizontal traction force applied in longitudinal rearward direction, of 200 daN  $\pm$  10 % applied statically to the geometric centre of the relevant perpendicular projected surface, at a maximum pressure of 2,0 MPa. The devices and equipment may deform, but the system for adjustment and locking shall not release as a result of the applied forces. The deformation shall be limited to ensure that the maximum authorised width of the vehicle is not exceeded by more than 25 mm on each side of the vehicle and the maximum authorised length of the vehicle is not exceeded by more than 200 mm.
- 1.3.1.3. It shall be verified by the technical service, to the satisfaction of the type-approval authority that aerodynamic devices and equipment positioned in both, the in-use and the retracted or folded positions, do not significantly impair cooling and ventilation of the powertrain, exhaust system and passenger cabin. All other applicable requirements relating to the vehicle systems shall be fully complied with when the devices and equipment are placed in both their in-use and retracted or folded positions.

By way of derogation concerning the applicable requirements relating to rear underrun protection, the horizontal distances between the rear of the rear underrun protection device and the rear extremity of the vehicle as fitted with aerodynamic devices and equipment may be measured without taking

the devices and equipment into account on condition that they exceed 200 mm in length, they are in the in-use condition and the fundamental sections of the elements placed at a height  $\leq 2,0$  m above the ground measured in unladen condition are made of material having a hardness of  $< 60$  Shore (A). Narrow ribs, tubing and metal wire forming a frame or substrate to support the fundamental sections of the elements shall not be taken into account when determining the hardness. However, in order to eliminate the risk of injuries and penetration of other vehicles in the event of a collision, any ends of such ribs, tubing and metal wire shall not be directed rearward, with the device and equipment both in the retracted or folded and the in-use positions.

As alternative to the derogation referred to in the previous paragraph, the horizontal distances between the rear of the rear underrun protection device and the rear extremity of the vehicle as fitted with aerodynamic devices and equipment may be measured without taking the aerodynamic devices and equipment into account provided that they exceed 200 mm in length, they are in the in-use condition and those devices or equipment comply with the test provisions set out in Appendix 4.

The horizontal distances between the rear of the rear underrun protection device and the rear extremity of the vehicle shall however be measured with the aerodynamic devices and equipment positioned in the retracted or folded position or take into account the resulting projection length in accordance with point 1.6.1 of Appendix 4, if this length exceeds that of the retracted or folded position.;

(c) the following points 2.1.3., 2.1.3.1. and 2.1.3.2. are inserted:

2.1.3. In the case of alternatively fuelled or zero-emission motor vehicles:

2.1.3.1. The additional weight required for alternative fuel or zero-emission technology in accordance with points 2.3. and 2.4. of Annex I to Directive 96/53/EC shall be defined on the basis of the documentation provided by the manufacturer. The correctness of the declared information shall be verified by the Technical Service, to the satisfaction of the Type-Approval Authority.

2.1.3.2. The manufacturer shall indicate the following additional symbol as well as the value of the additional weight below or to the side of the mandatory inscriptions on the manufacturer's statutory plate, outside a clearly marked rectangle which shall enclose only the mandatory information.

"96/53/EC ARTICLE 10B COMPLIANT – XXXX KG"

The height of the symbol's characters and stated value shall not be less than 4 mm.

In addition, until the introduction of a dedicated entry in the Certificate of Conformity, the value of the additional weight shall be stated under "remarks" in the Certificate of Conformity as to allow inclusion of this information in on-board vehicle registration papers.;

(d) the following point 2.2.5.1. is inserted:

---

*Status: This is the original version (as it was originally adopted).*

---

- 2.2.5.1 In the case of an articulated vehicle with at least 4 axles of class I having two steered axles, the mass corresponding to the load on the front steering axle(s) shall in no case be less than 15 % of the technically permissible maximum laden mass “M”;
- (e) in point 6.1, the following sentence is added:
- The requirements in this point shall not apply to the electric-only driving mode of hybrid electric vehicles.;
- (f) point 6.2. is replaced by the following:
- 6.2. The engine power shall be measured in accordance with UNECE Regulation No 85<sup>(6)</sup>.;
- (g) in point 7.1.1., the following sentence is added:
- If the vehicle is equipped with aerodynamic devices or equipment referred to in points 1.3.1.1 and 1.3.1.2, the devices and equipment shall be in the deployed and in-use position;
- (h) the following point 7.4. is inserted:
- 7.4 With the agreement of the Technical Service and the Type-Approval Authority, the manoeuvrability requirements may be proved by numerical simulation in accordance with Annex XVI to Directive 2007/46/EC. In case of doubt, the Technical Service or Type-Approval Authority may require a physical full-scale test to be carried out.;
- (i) in point 8.1.1., the following sentence is added:
- If the vehicle is equipped with aerodynamic devices or equipment referred to in points 1.3.1.1 and 1.3.1.2, the devices and equipment shall be in the deployed and in-use position;
- (j) the following point 8.3. is added:
- 8.3. With the agreement of the Technical Service and the Type-Approval Authority, the maximum rear swing-out requirements may be proved by numerical simulation in accordance with Annex XVI to Directive 2007/46/EC. In case of doubt, the Technical Service or Type-Approval Authority may require a physical full-scale test to be carried out.;
- (3) Part C is amended as follows:
- (a) in point 1.1.2., letter (b) is replaced by the following:
- (b) 2,60 m for vehicles fitted with a bodywork with insulated walls of at least 45 mm thick, having bodywork code 04 or 05 of Appendix 2 to Annex II to Directive 2007/46/EC.;
- (b) point 1.3 is replaced by the following:
- 1.3. The devices and equipment referred to in Appendix 1 shall not be taken into account for the determination of the length, width and height.;



- (c) the following points 1.3.1. to 1.4.2. are inserted:
- 1.3.1. Additional requirements for aerodynamic devices referred to in Appendix 1
    - 1.3.1.1. Aerodynamic devices and equipment not exceeding 500 mm in length in the in-use position shall not increase the usable length of the loading area. They shall be constructed in such a way as to make it possible to lock them in both the retracted or folded and the in-use positions. Such devices and equipment shall furthermore be constructed so as to be retractable or foldable when the vehicle is at stand-still in such a way that the maximum authorised width of the vehicle is not exceeded by more than 25 mm on each side of the vehicle and the maximum authorised length of the vehicle is not exceeded by more than 200 mm as permitted only from a height above the ground of at least 1 050 mm so that they do not impair the capability of the vehicle to be used for intermodal transport. In addition, the requirements set out in points 1.3.1.1.1 and 1.3.1.1.3. shall be met.
      - 1.3.1.1.1. The devices and equipment shall be type-approved in accordance with this Regulation.
      - 1.3.1.1.2. It shall be possible for the operator to vary the position of the aerodynamic device and equipment, and to retract or fold it, by applying a manual force not exceeding 40 daN. In addition, this may be done automatically as well.
      - 1.3.1.1.3. It is not required for devices and equipment to be retractable or foldable if the maximum dimensional requirements are fully complied with under all conditions.
    - 1.3.1.2. Aerodynamic devices and equipment exceeding 500 mm in length in the in-use position shall not increase the usable length of the loading area. They shall be constructed in such a way as to make it possible to lock them in both the retracted or folded and in-use positions. Such devices shall furthermore be constructed so as to be retractable or foldable when the vehicle is at stand-still in such a way that the maximum authorised width of the vehicle is not exceeded by more than 25 mm on each side of the vehicle and the maximum authorised length of the vehicle is not exceeded by more than 200 mm as permitted only from a height above the ground of at least 1 050 mm so that they do not impair the capability of the vehicle to be used for intermodal transport. In addition, the requirements set out in points 1.3.1.2.1. to 1.3.1.2.4. below shall be met.
      - 1.3.1.2.1. The devices and equipment shall be type-approved in accordance with this Regulation.
      - 1.3.1.2.2. It shall be possible for the operator to vary the position of the aerodynamic device and equipment, and retract or fold it, by applying a manual force not exceeding 40 daN. In addition, this may be done automatically as well.

---

*Status: This is the original version (as it was originally adopted).*

---

- 1.3.1.2.3. Each main vertical element or combination of elements and main horizontal element or combination of elements forming the devices and equipment shall, when installed on the vehicle and in the in-use position, withstand vertical and horizontal traction and push forces, applied sequentially in up, down, left and right direction, of 200 daN  $\pm$  10 % applied statically to the geometric centre of the relevant perpendicular projected surface, at a maximum pressure of 2,0 MPa. The devices and equipment may deform, but the system for adjustment and locking shall not release as a result of the applied forces. The deformation shall be limited to ensure that the maximum authorised width of the vehicle is not exceeded by more than 25 mm on each side of the vehicle, during and after the test.
- 1.3.1.2.4. Each main vertical element or combination of elements and main horizontal element or combination of elements forming the devices and equipment shall also, when in the retracted or folded position, withstand a horizontal traction force applied in longitudinal rearward direction, of 200 daN  $\pm$  10 % applied statically to the geometric centre of the relevant perpendicular projected surface, at a maximum pressure of 2,0 MPa. The devices and equipment may deform, but the system for adjustment and locking shall not release as a result of the applied forces. The deformation shall be limited to ensure that the maximum authorised width of the vehicle is not exceeded by more than 25 mm on each side of the vehicle and the maximum authorised length of the vehicle is not exceeded by more than 200 mm.
- 1.3.1.3. Aerodynamic devices and equipment of cabs, both in the retracted or folded and in-use position, where applicable, shall be constructed in such a way that the maximum authorised width of the vehicle is not exceeded by more than 25 mm on each side of the vehicle and that they do not impair the capability of the vehicle to be used for intermodal transport. In addition, the requirements set out in points 1.3.1.3.1. to 1.3.1.3.4. below shall be met.
- 1.3.1.3.1. Aerodynamic devices and equipment for cabs shall be type-approved in accordance with this Regulation.
- 1.3.1.3.2. When installed on a vehicle and both in the retracted or folded and in-use positions, where applicable, no part of the device and equipment shall be above the lower windscreen edge, unless it is not directly visible to the driver due to the instrument panel or other standard interior fittings.
- 1.3.1.3.3. The device and equipment shall be covered with energy absorbing material. Alternatively, the device and equipment shall consist of material having a hardness of < 60 Shore (A) in accordance with point 1.3.1.4..
- 1.3.1.3.4. The device and equipment shall not be constructed of material that is prone to breakage into sharp fragments or jagged edges.
- 1.3.1.4. It shall be verified by the technical service, to the satisfaction of the type-approval authority that aerodynamic devices and equipment

referred to in points 1.3.1.1, 1.3.1.2 and 1.3.1.3 positioned in both, the in-use and retracted or folded positions, do not impair the driver's forward field of vision and the windscreen wash and wipe functions, as well as do not significantly impair the cooling and ventilation of the powertrain, exhaust system, braking system, occupant cabin and loading area. All other applicable requirements relating to the vehicle systems shall be fully complied with when the devices and equipment are placed in both their in-use and retracted or folded positions.

By way of derogation concerning the applicable requirements relating to front underrun protection, the horizontal distances between the foremost part of the vehicle as fitted with aerodynamic devices and equipment and its front underrun protective device as well as the rear of the rear underrun protection device and the rear extremity of the vehicle as fitted with aerodynamic devices and equipment may be measured without taking the devices and equipment into account on condition that at the rear they exceed 200 mm in length and they are in the in-use condition and that at the front and rear the fundamental sections of the elements placed at a height  $\leq 2,0$  m above the ground measured in unladen condition are made of material having a hardness of  $< 60$  Shore (A). Narrow ribs, tubing and metal wire forming a frame or substrate to support the fundamental sections of the elements shall not be taken into account when determining the hardness. However, in order to eliminate the risk of injuries and penetration of other vehicles in the event of a collision, any ends of such ribs, tubing and metal wire shall not be directed forward at the front and rearward at the rear of the vehicle, with the device and equipment both in the retracted or folded and the in-use positions.

As alternative to the derogation concerning the rear underrun protection device referred to in the previous paragraph, the horizontal distances between the rear of the rear underrun protection device and the rear extremity of the vehicle as fitted with aerodynamic devices and equipment may be measured without taking the aerodynamic devices and equipment into account provided that they exceed 200 mm in length, they are in the in-use condition and those devices or equipment comply with the test provisions set out in Appendix 4.

The horizontal distances between the rear of the rear underrun protection device and the rear extremity of the vehicle shall however be measured with the aerodynamic devices and equipment positioned in the retracted or folded position or take into account the resulting projection length in accordance with point 1.6.1 of Appendix 4, if this length exceeds that of the retracted or folded position.

#### 1.4. Elongated cabs

1.4.1. Where the front fascia of the motor vehicle's cab location, including all external projections of for example the chassis, bumper, wheel guards and wheels, fully conforms to parameters of the three-dimensional envelope as set out in Appendix 5 and the length of the loading area does not exceed 10,5 m, the vehicle may exceed the maximum authorised length set out in point 1.1.1.

1.4.2. In the case referred to in point 1.4.1, the manufacturer shall indicate the following additional symbol below or to the side of

---

*Status: This is the original version (as it was originally adopted).*

---

the mandatory inscriptions on the manufacturer's statutory plate, outside a clearly marked rectangle which shall enclose only the mandatory information.

"96/53/EC ARTICLE 9A COMPLIANT"

The height of the symbol's characters shall not be less than 4 mm. The text "96/53/EC ARTICLE 9A COMPLIANT" shall also be added to the "remarks" in the Certificate of Conformity as to allow inclusion of this information in on-board vehicle registration papers.;

(d) the following points 2.1.4., 2.1.4.1. and 2.1.4.2. are inserted:

2.1.4. In the case of alternatively fuelled or zero-emission motor vehicles:

2.1.4.1. The additional weight required for alternative fuel or zero-emission technology in accordance with point 2.3. of Annex I to Directive 96/53/EC shall be defined on the basis of the documentation provided by the manufacturer. The correctness of the declared information shall be verified by the Technical Service, to the satisfaction of the Type-Approval Authority.

2.1.4.2. The manufacturer shall indicate the following additional symbol as well as the value of the additional weight below or to the side of the mandatory inscriptions on the manufacturer's statutory plate, outside a clearly marked rectangle which shall enclose only the mandatory information.

"96/53/EC ARTICLE 10B COMPLIANT – XXXX KG"

The height of the symbol's characters and stated value shall not be less than 4 mm.

In addition, until the introduction of a dedicated entry in the Certificate of Conformity, the value of the additional weight shall be stated under "remarks" in the Certificate of Conformity as to allow inclusion of this information in on-board vehicle registration papers.;

(e) the following point 5.1.2. is inserted:

5.1.2. The requirements in points 5.1 and 5.1.1 shall not apply to the electric-only driving mode of hybrid electric vehicles.;

(f) point 5.2. is replaced by the following:

5.2. The engine power shall be measured in accordance with UNECE Regulation No 85.;

(g) in point 6.1.1., the following sentence is added:

If the vehicle is equipped with aerodynamic devices or equipment referred to in points 1.3.1.1, 1.3.1.2 and 1.3.1.3, the devices and equipment shall be in the deployed and in-use position or in the fixed in-use position where applicable for devices and equipment covered by point 1.3.1.3.;

(h) the following point 6.4. is inserted:

- 6.4 With the agreement of the Technical Service and the Type-Approval Authority, the manoeuvrability requirements may be proved by numerical simulation in accordance with Annex XVI to Directive 2007/46/EC. In case of doubt, the Technical Service or Type-Approval Authority may require a physical full-scale test to be carried out.;
- (i) in point 7.1. the following sentence is added:
- If the vehicle is equipped with aerodynamic devices or equipment referred to in points 1.3.1.1, 1.3.1.2 and 1.3.1.3, the devices and equipment shall be in the deployed and in-use position.;
- (j) the following point 7.3. is added:
- 7.3. With the agreement of the Technical Service and the Type-Approval Authority, the maximum rear swing-out requirements may be proved by numerical simulation in accordance with Annex XVI to Directive 2007/46/EC. In case of doubt, the Technical Service or Type-Approval Authority may require a physical full-scale test to be carried out.;
- (4) Part D is amended as follows:
- (a) in point 1.1.2., letter (b) is replaced by the following:
- (b) 2,60 m for vehicles fitted with a bodywork with insulated walls of at least 45 mm thick, having bodywork code 04 or 05 of Appendix 2 to Annex II to Directive 2007/46/EC.;
- (b) point 1.4. is replaced by the following:
- 1.4. The devices and equipment referred to in Appendix 1 shall not be taken into account for the determination of the length, width and height.;
- (c) the following points 1.4.1. to 1.4.1.3. are inserted:
- 1.4.1. Additional requirements for aerodynamic devices referred to in Appendix 1
- 1.4.1.1. Aerodynamic devices and equipment not exceeding 500 mm in length in the in-use position shall not increase the usable length of the loading area. They shall be constructed in such a way as to make it possible to lock them in both the retracted or folded and the in-use positions. Such devices and equipment shall furthermore be constructed so as to be retractable or foldable when the vehicle is at stand-still in such a way that the maximum authorised width of the vehicle is not exceeded by more than 25 mm on each side of the vehicle and the maximum authorised length of the vehicle is not exceeded by more than 200 mm as permitted only from a height above the ground of at least 1 050 mm so that they do not impair the capability of the vehicle to be used for intermodal transport. In addition, the requirements set out in points 1.4.1.1.1 to 1.4.1.1.3. shall be met.

---

*Status: This is the original version (as it was originally adopted).*

---

- 1.4.1.1.1. The devices and equipment shall be type-approved in accordance with this Regulation.
- 1.4.1.1.2. It shall be possible for the operator to vary the position of the aerodynamic device and equipment, and to retract and fold it, by applying a manual force not exceeding 40 daN. In addition, this may be done automatically as well.
- 1.4.1.1.3. It is not required for devices and equipment to be retractable or foldable if the maximum dimensional requirements are fully complied with under all conditions.
- 1.4.1.2. Aerodynamic devices and equipment exceeding 500 mm in length in the in-use position shall not increase the usable length of the loading area. They shall be constructed in such a way to make it possible to lock them in both the retracted or folded and the in-use positions. Such devices shall furthermore be constructed so as to be retractable or foldable when the vehicle is at stand-still in such a way that the maximum authorised width of the vehicle is not exceeded by more than 25 mm on each side of the vehicle and the maximum authorised length of the vehicle is not exceeded by more than 200 mm as permitted only from a height above the ground of at least 1 050 mm so that they do not impair the capability of the vehicle to be used for intermodal transport. In addition, the requirements set out in points 1.4.1.2.1. to 1.4.1.2.4. shall be met.
  - 1.4.1.2.1. The devices and equipment shall be type-approved in accordance with this Regulation.
  - 1.4.1.2.2. It shall be possible for the operator to vary the position of the aerodynamic device and equipment, and retract or fold it, by applying a manual force not exceeding 40 daN. In addition, this may be done automatically as well.
  - 1.4.1.2.3. Each main vertical element or combination of elements and main horizontal element or combination of elements forming the devices and equipment shall, when installed on the vehicle and in the in-use position, withstand vertical and horizontal traction and push forces, applied sequentially in up, down, left and right direction, of 200 daN  $\pm$  10 % applied statically to the geometric centre of the relevant perpendicular projected surface, at a maximum pressure of 2,0 MPa. The devices and equipment may deform, but the system for adjustment and locking shall not release as a result of the applied forces. The deformation shall be limited to ensure that the maximum authorised width of the vehicle is not exceeded by more than 25 mm on each side of the vehicle, during and after the test.
  - 1.4.1.2.4. Each main vertical element or combination of elements and main horizontal element or combination of elements forming the devices and equipment shall also, when in the retracted or folded position, withstand a horizontal traction force applied in longitudinal rearward direction, of 200 daN  $\pm$  10 % applied statically to the geometric centre of the relevant perpendicular projected surface, at a maximum pressure of 2,0 MPa. The devices and equipment

may deform, but the system for adjustment and locking shall not release as a result of the applied forces. The deformation shall be limited to ensure that the maximum authorised width of the vehicle is not exceeded by more than 25 mm on each side of the vehicle and the maximum authorised length of the vehicle is not exceeded by more than 200 mm.

- 1.4.1.3. It shall be verified by the technical service, to the satisfaction of the type-approval authority that aerodynamic devices and equipment positioned in both, the in-use and the retracted or folded positions, do not completely block the ventilation of the loading area. All other applicable requirements relating to the vehicle systems shall be fully complied with when the devices and equipment are placed in both their in-use and retracted or folded positions.

By way of derogation concerning the applicable requirements relating to rear underrun protection, the horizontal distances between the rear of the rear underrun protection device and the rear extremity of the vehicle as fitted with aerodynamic devices and equipment may be measured without taking the devices and equipment into account on condition that they exceed 200 mm in length, they are in the in-use condition and the fundamental sections of the elements placed at a height  $\leq 2,0$  m above the ground measured in unladen condition are made of material having a hardness of  $< 60$  Shore (A). Narrow ribs, tubing and metal wire forming a frame or substrate to support the fundamental sections of the elements shall not be taken into account when determining the hardness. However, in order to eliminate the risk of injuries and penetration of other vehicles in the event of a collision, any ends of such ribs, tubing and metal wire shall not be directed rearward at the rear of the vehicle, with the device and equipment both in the retractable or folded and the in-use positions.

As alternative to the derogation referred to in the previous paragraph, the horizontal distances between the rear of the rear underrun protection device and the rear extremity of the vehicle as fitted with aerodynamic devices and equipment may be measured without taking the aerodynamic devices and equipment into account provided that they exceed 200 mm in length, they are in the in-use condition and those devices or equipment comply with the test provisions set out in Appendix 4.

The horizontal distances between the rear of the rear underrun protection device and the rear extremity of the vehicle shall however be measured with the aerodynamic devices and equipment positioned in the retracted or folded position or take into account the resulting projection length in accordance with point 1.6.1 of Appendix 4, if this length exceeds that of the retracted or folded position.;

- (d) point 2.2.1. is replaced by the following:

2.2.1. The sum of the technically permissible maximum mass at the front coupling point plus the technically permissible maximum mass on the solo axles and/or group(s) of axles plus the technically permissible maximum mass at the rear coupling point shall be not less than the technically permissible maximum laden mass of the vehicle.

---

*Status: This is the original version (as it was originally adopted).*

---

$$M \leq \Sigma [m_0 + m_i + m_c] \text{ or } M \leq \Sigma [m_0 + \mu_j + m_c];$$

- (e) in point 3.1. the following sentence is added:

If the trailer or semi-trailer is equipped with aerodynamic devices or equipment referred to in points 1.4.1.1 or 1.4.1.2, the devices and equipment shall be in the in-use and deployed position.;

- (f) point 3.2 is replaced by the following:

3.2. A semi-trailer not equipped with aerodynamic devices or equipment referred to in points 1.4.1.1 or 1.4.1.2 shall be deemed to comply with the requirement set out in point 3.1. if its reference wheelbase “RWB” meets the following requirement:

$$RWB \leq [(12,50 - 2,04)^2 - (5,30 + \frac{1}{2} W)^2]^{1/2}$$

where:

“RWB” is the distance between the king-pin axis and the centre line of the non-steering axles.  
 “W” is the semi-trailer’s width;

- (5) Appendix 1 is amended as follows:

- (a) points 1 and 2 are replaced by the following:

1. Subject to the additional restrictions provided in the following tables, the devices and equipment listed in Tables I, II and III are not required to be taken into account for the determination and calculation of the outermost dimensions where the following requirements are fulfilled:

- (a) where devices are fitted at the front, with the exception of aerodynamic devices and equipment of cabs, the total protrusion of those devices shall not exceed 250 mm;
- (b) the total protrusion of devices and equipment added to the length of the vehicle, with the exception of aerodynamic devices and equipment, shall not exceed 750 mm;
- (c) the total protrusion of devices and equipment added to the width of the vehicle shall not exceed 100 mm.

2. The requirements set out in points (a), (b) and (c) of point 1 shall not apply to devices for indirect vision.;

- (b) Table I is amended as follows:

- (i) the row with item number 6 is replaced by the following:

6.	Mechanical couplings	X	X	X	X					
----	----------------------	---	---	---	---	--	--	--	--	--

- (ii) the row with item number 18 is replaced by the following:



18.	Aerodynamic devices and equipment	X	X		X	X			X	X
-----	-----------------------------------	---	---	--	---	---	--	--	---	---

(iii) the following row with item number 19 is added:

19.	Antennas used for vehicle to vehicle or vehicle-to-infrastructure communication	X	X	X	X	X	X	X	X	X
-----	---	---	---	---	---	---	---	---	---	---

(c) Table II is amended as follows:

(i) the row with item number 11 is replaced by the following:

11.	Aerodynamic devices and equipment. The vehicle width, including that of conditioned body with insulated walls, shall not exceed 2 600 mm including the measured projections, with the devices	X			X	X			X	X
-----	---	---	--	--	---	---	--	--	---	---

*Status: This is the original version (as it was originally adopted).*

and equipment fixed in both the retracted or folded and the in-use positions.											
---	--	--	--	--	--	--	--	--	--	--	--

(ii) the following row with item number 18 is added:

18.	Antennas used for vehicle-to-vehicle or vehicle-to-infrastructure communication	X	X	X	X	X	X	X	X	X	X
-----	---	---	---	---	---	---	---	---	---	---	---

(iii) the following row with item number 19 is added:

19.	Flexible hoses of tyre pressure monitoring systems provided that they do not protrude by more than 70 mm on each side					X			X	X	
-----	---	--	--	--	--	---	--	--	---	---	--

from the outermost width of the vehicle												
---	--	--	--	--	--	--	--	--	--	--	--	--

(d) Table III is replaced by the following:

TABLE III

**Vehicle height**

		M <sub>1</sub>	M <sub>2</sub>	M <sub>3</sub>	N <sub>1</sub>	N <sub>2</sub>	N <sub>3</sub>	O <sub>1</sub>	O <sub>2</sub>	O <sub>3</sub>	O <sub>4</sub>
1.	Antennas used for radio, navigation, vehicle-to-vehicle or vehicle-to-infrastructure communication	X	X	X	X	X	X	X	X	X	X
2.	Pantographs or trolley booms in their elevated position			X			X				

(6) the following Appendices 4 and 5 are added:

Appendix 4

**Aerodynamic device and equipment crash test**

1. Test conditions for aerodynamic devices and equipment
  - 1.1. At the request of the manufacturer the test shall be conducted on one of the following:
    - 1.1.1. on a vehicle of the type for which an aerodynamic device and equipment is intended;

---

*Status: This is the original version (as it was originally adopted).*

---

- 1.1.2. on a part of the body of the vehicle type for which the aerodynamic device and equipment is intended; that part shall be representative of the vehicle type(s) in question;
- 1.1.3. on a rigid wall.
- 1.2. Where the test is conducted as referred to in points 1.1.2. and 1.1.3., the parts used to connect the aerodynamic devices and equipment to a part of the vehicle body or to a rigid wall shall be equivalent to those which are used to secure the aerodynamic devices and equipment when it is installed on the vehicle. Every device shall be accompanied by installation and operating instructions giving sufficient information for any competent person to install it correctly.
- 1.3. At the request of the manufacturer the test procedure described in point 1.5. may be conducted by numerical simulation in accordance with Annex XVI to Directive 2007/46/EC.

The mathematical model shall be validated only if it is comparable with the physical test conditions. To that effect, a physical test shall be conducted for the purposes of comparing the results obtained when using the mathematical model with the results of a physical test. Comparability of the test results shall be proven. A validation report shall be drafted by the manufacturer.

Any change made to the mathematical model or to the software likely to invalidate the validation report shall require a new validation in accordance with the previous paragraph.

- 1.4. Conditions for the conduct of tests or simulations.
  - 1.4.1. The vehicle shall be at rest on a level, flat, rigid and smooth surface.
  - 1.4.2. Any front wheels shall be in the straight ahead position.
  - 1.4.3. The tyres shall be inflated to the pressure recommended by the vehicle manufacturer.
  - 1.4.4. The vehicle shall be unladen.
  - 1.4.5. The vehicle may, if necessary to achieve the test force required in point 1.5.1.2., be restrained by any method. This method shall be specified by the vehicle manufacturer.
  - 1.4.6. Vehicles equipped with hydropneumatic, hydraulic or pneumatic suspension or a device for automatic levelling according to load shall be tested with the suspension or device in the normal running condition specified by the manufacturer.
- 1.5. Test procedure
  - 1.5.1. The tests shall be carried out to assess that the aerodynamic device and equipment offer a specified level of deformation to forces applied parallel to the longitudinal axis of the vehicle as referred to in point 1.6.1. Alternatively, the device may also become folded or retracted under the influence of force. The fulfilment of the requirement referred to in point 1.6.2. shall be verified by means of suitable test mandrels for the purpose of the crash test. The device used to distribute the test force over the stated flat surface shall be

connected to the force actuator through a swivel joint. In cases of geometric incompatibilities an adaptor may be used instead of a device with a flat surface.

- 1.5.1.1. A force shall be applied parallel to the longitudinal axis of the vehicle via a surface or adaptor not more than 250 mm in height and 200 mm wide with a radius of curvature of  $5 \pm 1$  mm at the vertical edges. The surface shall not be rigidly fixed to the aerodynamic device and equipment and shall be articulated in all directions. When the test is carried out on a vehicle as referred to in point 1.1.1., the height of the lower edge of the surface or adaptor shall be specified by the manufacturer in an area between the lowest edge of the aerodynamic device and equipment and a point of the upper edge of the surface or adaptor that is no more than 2,0 m above the ground in vehicle-mounted condition (see figure 1). This point is to be specified on a laden vehicle with the technically permissible maximum laden mass.

Where the test is carried out on a part of the body of the vehicle type as referred to in point 1.1.2. or on a rigid wall as referred to in point 1.1.3., the height of the centre of the surface or adaptor shall be specified by the manufacturer in an area between the lowest edge of the aerodynamic device and equipment and the point that represents the height of no more than 2,0 m above the ground in vehicle-mounted condition on a laden vehicle with the technically permissible maximum laden mass (see figure 2).

The exact location of the centre of the surface or adaptor in the area of application of forces shall be specified by the manufacturer. Where the aerodynamic device and equipment have different degrees of stiffness in the area of application of the forces (e.g. due to reinforcements, different materials or thicknesses, etc.), the location of the centre of the surface or adaptor shall be located in the area with the highest resistance against external forces in longitudinal direction of the vehicle.

Figure 1 Test point height

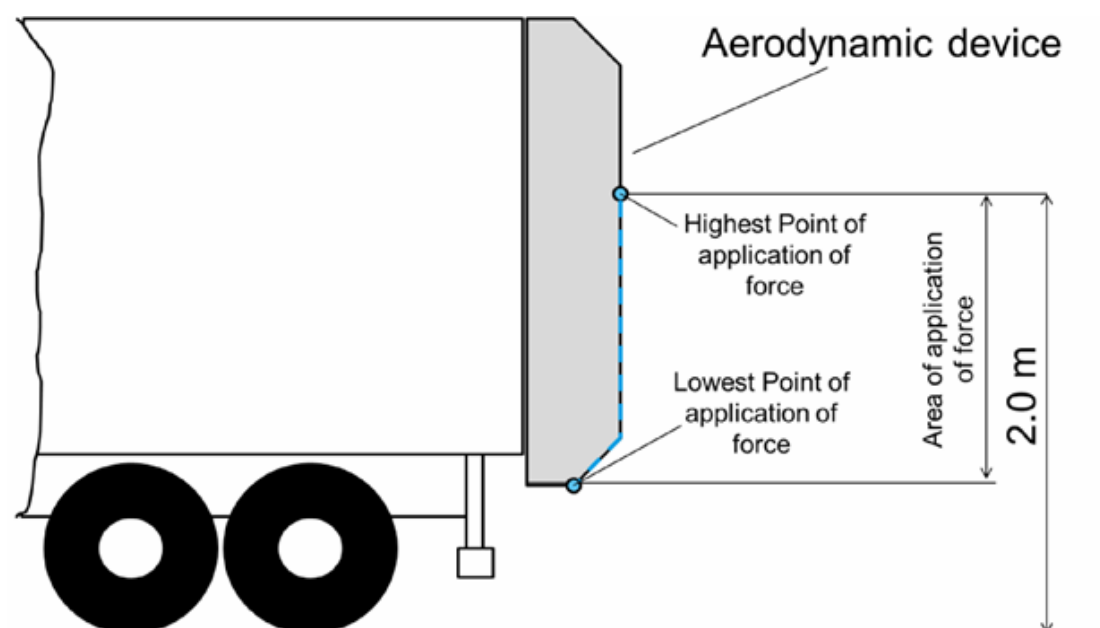
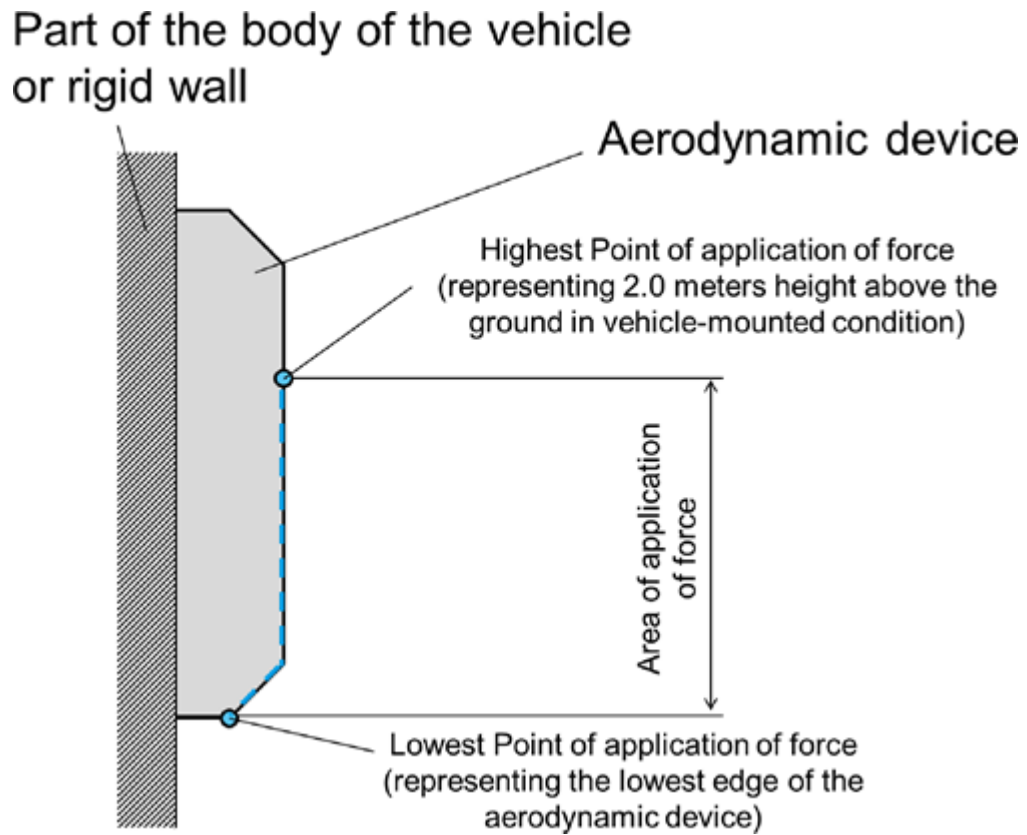

Figure 2 Example of test setup

Status: This is the original version (as it was originally adopted).



- 1.5.1.2. A horizontal force of maximum  $4\,000\text{ N} \pm 400\text{ N}$  shall be applied consecutively to two points situated symmetrically about the centre line of the vehicle or the centre line of the device on the rearmost outer edge of the aerodynamic device and equipment in completely unfolded or in-use position (see figure 3). The order in which the forces are applied may be specified by the manufacturer.

Figure 3 Force application

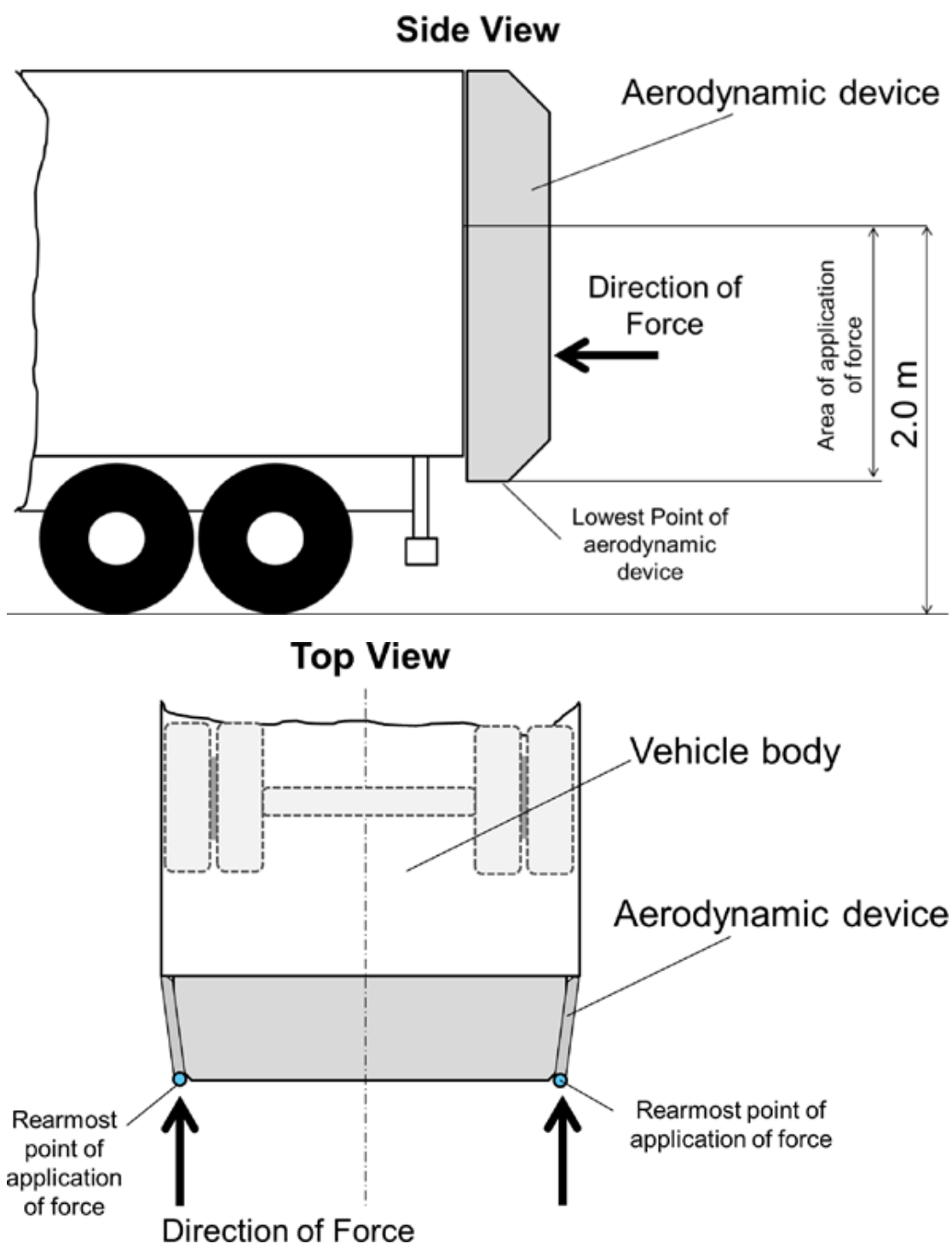

## 1.6. Requirements

- 1.6.1. The aerodynamic device and equipment shall be so fitted that, during the application of the test forces as specified in point 1.5.1.2., the device and equipment deforms, retracts or folds resulting in projection length of  $\leq 200$  mm measured in horizontal longitudinal direction at the points of application of the forces. The resulting projection length shall be recorded.

- 1.6.2. The aerodynamic device and equipment shall not endanger the occupants of other vehicles in a rear-end collision and shall not affect the operation of the rear underrun protection device.

## Appendix 5

### Three-dimensional cab envelope

1. General procedure for the checking of conformity of the motor vehicle with the parameters relating to the three-dimensional cab envelope
  - 1.1. Vertical boundaries of the motor vehicle cab assessment zone
    - 1.1.1. The maximum width of the vehicle at cab location  $W_c$  shall be taken forward of the vertical transverse plane located at the foremost axle of the motor vehicle. The items listed in Appendix 1 shall not be taken into account for the purposes of this measurement.
    - 1.1.2. The assessment zone of the motor vehicle's cab location shall be considered in such a way that it corresponds with the maximum width  $W_c$ . The zone shall be bounded by vertical longitudinal planes that are parallel to the longitudinal median plane of the motor vehicle and that are distance  $W_c$  apart.
    - 1.1.3. The horizontal longitudinal distance  $L_t$  shall be established from the most forward point of the motor vehicle's cab location taken at a height  $\leq 2\ 000$  mm from the ground measured in unladen condition.

The distance  $L_t$  shall be set at 200 mm for the purpose of this assessment (see figure 1).

The rear side of the assessment zone shall be bounded by a vertical transverse plane, perpendicular to the longitudinal median plane of the motor vehicle, that is located rearward of the abovementioned most forward point by distance  $L_t$ .

*Figure 1* 3D envelope



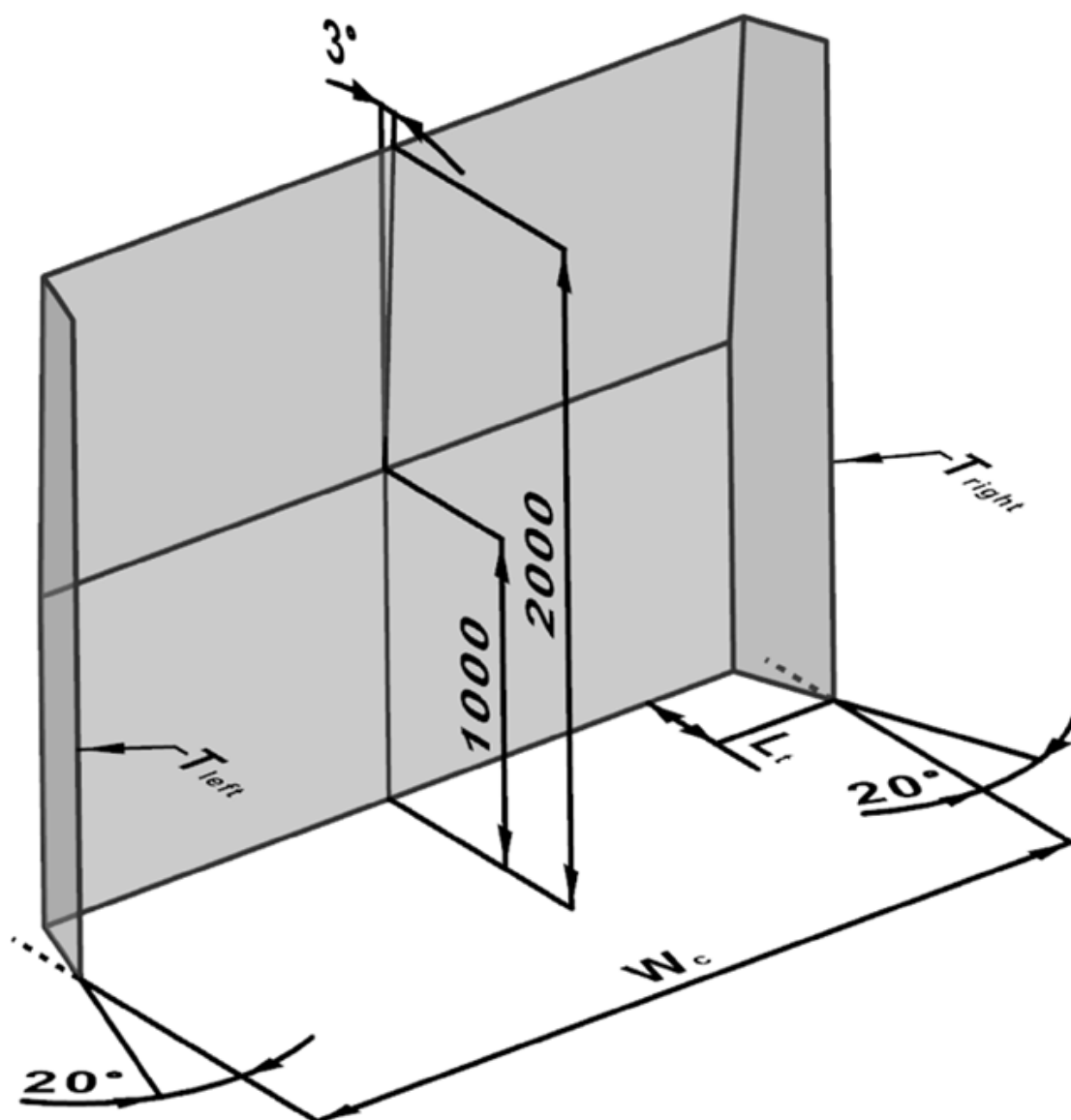

1.1.4. The intersections of the rear plane forming the side of the assessment zone with both angled outboard planes, lines  $T_{left}$  and  $T_{right}$ , shall be considered for the purpose of point 1.3.3.2. (see figure 2).

Figure 2 3D envelope

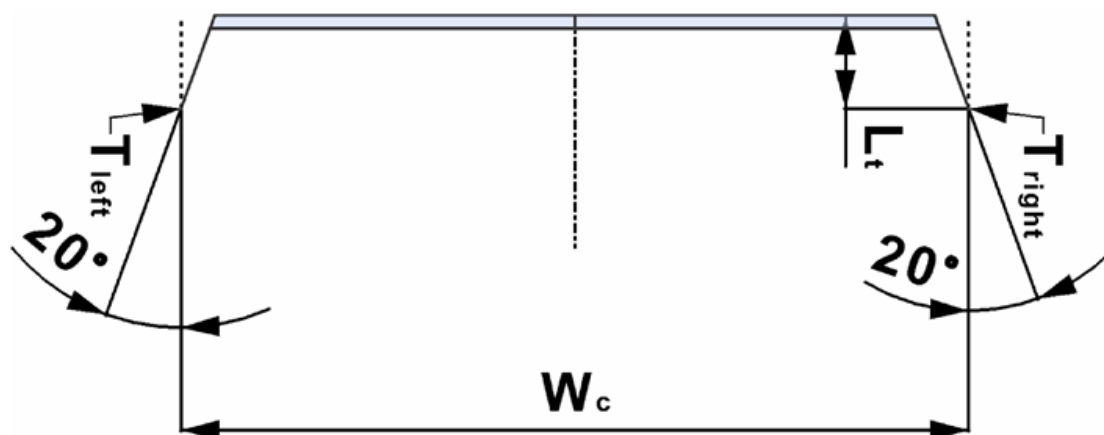

- 1.2. Horizontal boundaries of the motor vehicle cab assessment zone
  - 1.2.1. In the assessment zone, the lower front fascia boundary line shall be set at ground level and the upper front fascia boundary line shall be set at 2 000 mm above the ground as measured in unladen condition.
- 1.3. Specific provisions for the motor vehicle cab assessment zone
  - 1.3.1. For the purposes of this Appendix, the front fascia at the motor vehicle's cab location shall be considered, regardless of type of material. However, the items listed in Appendix 1 shall not be taken into account.
  - 1.3.2. Rake of the front of the cab
    - 1.3.2.1. For the purposes of this Appendix, "rake" shall be considered, meaning the rearward inclination of the motor vehicle's front fascia at the cab location from the vertical, where any point located above another point lies rearward of that other point.
    - 1.3.2.2. For the assessment zone of the rake, the most forward point of the motor vehicle's cab location as referred to in point 1.1.3. shall be considered.

The vertical transverse plane through the most forward point of the cab, taken at a height of  $\leq 2\,000$  mm from the ground measured in unladen condition, shall be considered as regards its intersection with the horizontal plane that is located at the height of 1 000 mm. The intersecting line shall then be taken as the base envelope line to assess the vehicle cab's rake in the given assessment zone.

- 1.3.2.3. A plane rotating around the base envelope line referred to in the second paragraph of point 1.3.2.2., inclined rearward from the vertical by  $3^\circ$ , shall be taken (see figure 3).

Figure 3 Rake

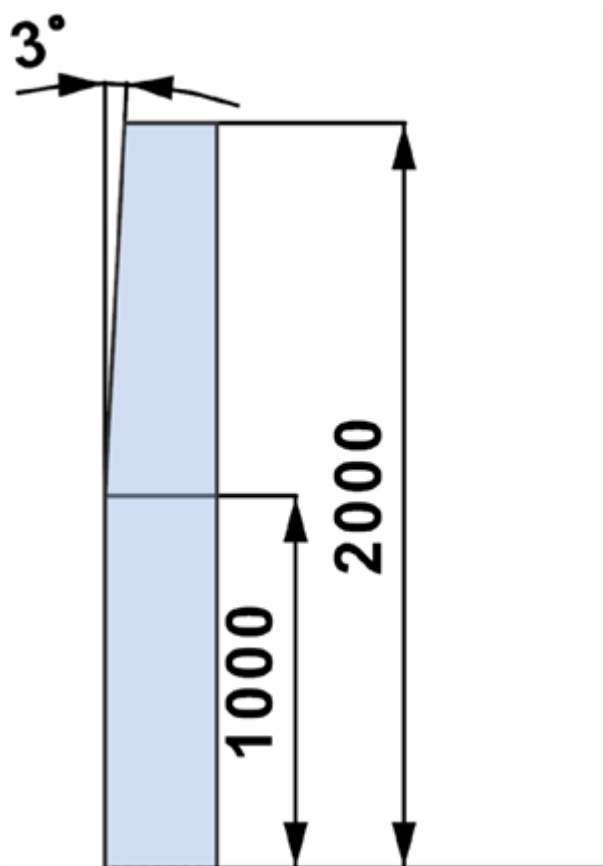

- 1.3.2.4. No point of the actual surface of the front fascia, as located in the assessment zone of the rake, shall lie forward of the rearward inclined plane referred to in point 1.3.2.3. when the most forward point of the motor vehicle's cab location touches the vertical transverse plane.
- 1.3.3. Tapering of the sides of the motor vehicle cab.
  - 1.3.3.1. In the assessment zone of the motor vehicle's cab location, the front fascia shall be tapered in such a way that the relevant nominal surfaces generally converge towards a common area that lies forward of the cab and in the longitudinal median plane of the motor vehicle.
  - 1.3.3.2. Two symmetrical vertical planes, one on the left side and one on the right side, shall be considered, both under a horizontal angle of  $20^\circ$  in relation to the longitudinal median plane and thus  $40^\circ$  apart. These planes are located in such a way that they also intersect with lines  $T_{left}$  and  $T_{right}$  referred to in point 1.1.3., respectively.
  - 1.3.3.3. No point of the actual surface of the front fascia, as located in the left and right outboard zone, shall lie outward of the respective vertical plane referred to in point 1.3.3.2. with the most forward point of the motor vehicle's cab location touching the vertical transverse plane referred to in point 1.3.2.4.
2. If any of the conditions set out in this Appendix are not met, it shall be considered that the motor vehicle cab does not conform to parameters of the

---

*Status: This is the original version (as it was originally adopted).*

---

three-dimensional envelope as referred to in point 1.4.1. of Part C of this Annex.

..

## ANNEX II

Annex V to Regulation (EU) No 1230/2012 is amended as follows:

- (1) Part A is amended as follows:
- (a) the title is replaced by the following:

### PART A

#### **EC type-approval of motor vehicles and their trailers with regard to the masses and dimensions of a vehicle**

#### **INFORMATION DOCUMENT**

#### **MODEL**

- (b) the following point 2.4.2.1.3. is inserted:
- 2.4.2.1.3. Elongated cab complying to Article 9a of Directive 96/53/EC: yes/  
no<sup>(1)</sup>
- (c) the following point 2.6.4. is inserted:
- 2.6.4. Additional mass for alternative propulsion: ... kg
- (d) the following point 3.9. is inserted:
- 3.9. List of equipment to for alternative propulsion (and indication of  
the mass of the parts): ...
- (e) the following points 9.25. to 9.27.3. are inserted:
- 9.25. Elongated Cabs complying to Article 9a of Directive 96/53/EC
- 9.25.1. Detailed technical description (including photographs and  
drawings, as well as description of the materials) of the vehicle  
parts relevant to Part C, point 1.4 of Annex I to Regulation (EU)  
No 1230/2012: ...
- 9.26. Aerodynamic device or equipment on the front of the vehicle
- 9.26.1. Vehicle equipped with aerodynamic device or equipment on the  
front: yes/no<sup>(1)</sup>
- 9.26.2. Type-approval number of the aerodynamic device or equipment, if  
available: ... or, if not available:

9.26.3. Detailed description (including photographs or drawings) of the aerodynamic device or equipment

9.26.3.1. Construction and materials: ...

9.26.3.2. Locking and adjustment system: ...

9.26.3.3. Attachment and mounting to the vehicle: ...

9.27. Aerodynamic device or equipment on the rear of the vehicle

9.27.1. Vehicle equipped with aerodynamic device or equipment on the rear: yes/no<sup>(1)</sup>

9.27.2. Type-approval number of the aerodynamic device or equipment, if available ... or, if not available:

9.27.3. Detailed description (including photographs or drawings) of the aerodynamic device or equipment

9.27.3.1. Construction and materials: ...

9.27.3.2. Locking and adjustment system: ...

9.27.3.3. Attachment and mounting to the vehicle: ...

(2) Part B is amended as follows:

(a) the title is replaced by the following:

## PART B

### **EC type-approval certificate of motor vehicles and their trailers with regard to the masses and dimensions of vehicles**

#### **MODEL**

**Format: A4 (210 × 297 mm)**

#### **EC TYPE-APPROVAL CERTIFICATE;**

(b) the words “with regard to Regulation (EU) No. .../...” are replaced by the words ‘with regard to Regulation (EU) No 1230/2012, as last amended by Regulation (EU) 2019/1892’;

(c) the Addendum is replaced by the following:

#### Addendum

#### **to EC type-approval certificate No ...**

1. Derogations

1.1. The vehicle has been type-approved in accordance with Article 6(1) of this Regulation (i.e. the outermost dimensions of the vehicle

---

*Status: This is the original version (as it was originally adopted).*

---

- exceeds the maximum dimensions mentioned in Part A, B, C or D of Annex I): yes/no<sup>(9)</sup>
- 1.2. The vehicle has been type-approved for the purposes of Article 8b of Directive 96/53/EC (i.e. aerodynamic devices or equipment at the rear of the vehicle): yes/no<sup>(9)</sup>
- 1.3. The vehicle has been type-approved for the purposes of with Article 9a of Directive 96/53/EC (i.e. an elongated cab or a cab fitted with aerodynamic devices or equipment): yes/no<sup>(9)</sup>
- 1.4. The vehicle has been type-approved for the purposes of Article 10b of Directive 96/53/EC:
- 1.4.1. Additional weight of alternatively fuelled vehicles: yes/no<sup>(9)</sup>
- 1.4.2. Additional weight of zero-emission vehicles: yes/no<sup>(9)</sup>
2. The vehicle is fitted with air-suspension: yes/no<sup>(9)</sup>
3. The vehicle is fitted with a suspension recognised to be equivalent to air-suspension: yes/no<sup>(9)</sup>
4. The vehicle fulfils the requirements for an off-road vehicle: yes/no<sup>(9)</sup>
5. Remarks: ...;
- (3) the following Parts C, D and E are added:

## PART C

### **EC type-approval of an aerodynamic device or equipment as a separate technical unit**

#### **Information document**

#### **MODEL**

Information document No ... relating to the EC type-approval of an aerodynamic device or equipment as a separate technical unit.

The following information shall be supplied in triplicate and include a list of contents. Any drawings shall be supplied in appropriate scale and in sufficient detail on size A4 or on a folder of A4 format. Photographs, if any, shall show sufficient detail.

If the separate technical units referred to in this information document have electronic controls, information concerning their performance shall also be supplied.

0. GENERAL
- 0.1. Make (trade name of manufacturer): ...
- 0.2. Type: ...

---

*Status: This is the original version (as it was originally adopted).*

---

- 0.3. Means of identification of type, if marked on the separate technical unit <sup>(b)</sup>:  
...
- 0.3.1. Location of that marking: ...
- 0.5. Name and address of manufacturer: ...
- 0.7. Location and method of affixing the EC type- approval mark: ...
- 0.8. Name(s) and address(es) of assembly plant(s): ...
- 0.9. Name and address of the manufacturer's representative (if any): ...
- 9.26. Aerodynamic device or equipment on the front of the vehicle
  - 9.26.1. Vehicle equipped with aerodynamic device or equipment on the front: yes/  
no <sup>(1)</sup>
  - 9.26.2. Type-approval number of the aerodynamic device or equipment, if available:  
... or, if not available:
  - 9.26.3. Detailed description (including photographs or drawings) of the  
aerodynamic device or equipment
    - 9.26.3.1. Construction and materials: ...
    - 9.26.3.2. Locking and adjustment system: ...
    - 9.26.3.3. Attachment and mounting to the vehicle: ...
- 9.27. Aerodynamic device or equipment on the rear of the vehicle
  - 9.27.1. Vehicle equipped with aerodynamic device or equipment on the rear: yes/  
no <sup>(1)</sup>
  - 9.27.2. Type-approval number of the aerodynamic device or equipment, if  
available ... or, if not available:
  - 9.27.3. Detailed description (including photographs or drawings) of the  
aerodynamic device or equipment
    - 9.27.3.1. Construction and materials: ...
    - 9.27.3.2. Locking and adjustment system: ...
    - 9.27.3.3. Attachment and mounting to the vehicle: ...

*Explanatory notes*

- <sup>(b)</sup> If the means of identification of type contains characters not relevant to describe the separate technical unit type covered by this information document, such characters shall be represented in the documentation by the symbol “?” (e.g. ABC??123??).
- <sup>(1)</sup> Delete where not applicable.

---

*Status: This is the original version (as it was originally adopted).*

---

## PART D

**EC type-approval certificate for an aerodynamic device or equipment as a separate technical unit**

## MODEL

Format: A4 (210 × 297 mm)

## EC TYPE-APPROVAL CERTIFICATE

Stamp of type-approval authority

Communication concerning:

<ul style="list-style-type: none"> <li>- EC type-approval <sup>(1)</sup></li> <li>- extension of EC type-approval <sup>(1)</sup></li> <li>- refusal of EC type-approval <sup>(1)</sup></li> <li>- withdrawal of EC type-approval <sup>(1)</sup></li> </ul>		of a type of aerodynamic device or equipment as a separate technical unit
--	--	---

with regard to Regulation (EU) No 1230/2012, as last amended by Regulation (EU) 2019/1892 <sup>(7)</sup>

EC type-approval number: ...

Reason for extension: ...

## SECTION 1.

I

Make (trade name of manufacturer): ...

0.2. Type: ...

0.3. Means of identification of type, if marked on the separate technical unit<sup>(8)</sup>: ...

0.3.1. Location of that marking: ...

0.5. Name and address of manufacturer: ...

0.7. Location and method of affixing of the EC type-approval mark: ...

0.8. Name(s) and address(es) of assembly plant(s): ...

0.9. Name and address of the manufacturer's representative (if any): ...

## SECTION 2.

II

Additional information: see Addendum.



---

*Status: This is the original version (as it was originally adopted).*

---

2. Technical service responsible for carrying out the tests: ...
3. Date of test report: ...
4. Number of test report: ...
5. Remarks (if any): see Addendum.
6. Place: ...
7. Date: ...
8. Signature: ...

Attachments: Information package

Test report

#### Addendum

##### **to EC type-approval certificate No ...**

1. Brief description of the type of separate technical unit: ...
2. Detailed description of the aerodynamic device or equipment:
  - 2.1. Number of separate elements: ...
  - 2.2. Description of construction and materials: ...
  - 2.3. Description of locking and adjustment system: ...
  - 2.4. Description of attachment and mounting to the vehicle: ...
  - 2.5. Separate technical unit: semi-universal/vehicle specific <sup>(1)</sup>
3. List of specific vehicle types for which the separate technical unit has been approved (if applicable): ...
4. Detailed description of the specific mounting area specifications on vehicles in case of semi-universal aerodynamic devices or equipment (if applicable):  
...
5. Remarks: ...
6. Type-approval mark and its location: ...

#### PART E

##### **EC separate technical unit type-approval mark**

1. The EC separate technical unit type-approval mark shall consist of:
  - 1.1. A rectangle surrounding the lower-case letter “e” followed by the distinguishing number of the Member State which has granted the EC separate technical unit type-approval:

---

*Status: This is the original version (as it was originally adopted).*

---

1	for Germany	19	for Romania
2	for France	20	for Poland
3	for Italy	21	for Portugal
4	for The Netherlands	23	for Greece
5	for Sweden	24	for Ireland
6	for Belgium	25	for Croatia
7	for Hungary	26	for Slovenia
8	for the Czech Republic	27	for Slovakia
9	for Spain	29	for Estonia
11	for the United Kingdom	32	for Latvia
12	for Austria	34	for Bulgaria
13	for Luxembourg	36	for Lithuania
17	for Finland	49	for Cyprus
18	for Denmark	50	for Malta

- 1.2. In the vicinity of the rectangle the “base approval number” contained in Section 4 of the type-approval number preceded by the two figures indicating the sequence number assigned to this Regulation or latest major technical amendment to this Regulation. The sequence number is “00” at present.
- 1.3. In case of an aerodynamic device or equipment of cabs, the sequence number shall be preceded by the symbol “96/53/EC ARTICLE 9A COMPLIANT”.
- 1.4. In case of an aerodynamic device or equipment to be located on the rear of a vehicle, the sequence number shall be preceded by the symbol “96/53/EC ARTICLE 8B COMPLIANT”.
2. The EC separate technical unit type-approval mark shall be affixed to a main part of the aerodynamic device or equipment in such a way as to be indelible as well as clearly and easily legible even if the device is fitted to a vehicle.
3. An example of an EC separate technical unit type-approval mark is shown in Figure 1.

**Figure 1 Example of EC separate technical unit type-approval mark**

96/53/EC ARTICLE 8B COMPLIANT 

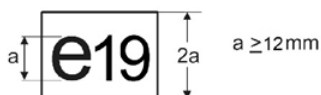

00 0046 

*Explanatory note*

The EC separate technical unit type-approval of an aerodynamic device or equipment to be installed at the rear of a vehicle (for the purpose of compliance with Article 8b of Directive 96/53/EC) was issued by Romania under number 0046. The first two digits “00” indicate that the separate technical unit was approved in accordance with this Regulation.

- (1) [OJ L 200, 31.7.2009, p. 1.](#)
- (2) Commission Regulation (EU) No 1230/2012 of 12 December 2012 implementing Regulation (EC) No 661/2009 of the European Parliament and of the Council with regard to type-approval requirements for masses and dimensions of motor vehicles and their trailers and amending Directive 2007/46/EC of the European Parliament and of the Council ([OJ L 353, 21.12.2012, p. 31](#)).
- (3) Council Directive 96/53/EC of 25 July 1996 laying down for certain road vehicles circulating within the Community the maximum authorised dimensions in national and international traffic and the maximum authorised weights in international traffic ([OJ L 235, 17.9.1996, p. 59](#)).
- (4) Directive (EU) 2015/719 of the European Parliament and of the Council of 29 April 2015 amending Council Directive 96/53/EC laying down for certain road vehicles circulating within the Community the maximum authorised dimensions in national and international traffic and the maximum authorised weights in international traffic ([OJ L 115, 6.5.2015, p. 1](#)).
- (5) Regulation (EU) 2019/1242 of the European Parliament and of the Council of 20 June 2019 setting CO<sub>2</sub> emission performance standards for new heavy-duty vehicles and amending Regulations (EC) No 595/2009 and (EU) 2018/956 of the European Parliament and of the Council and Council Directive 96/53/EC ([OJ L 198, 25.7.2019, p. 202](#)).
- (6) [OJ L 326, 24.11.2006, p. 55.](#)’;
- (7) Delete where not applicable.
- (8) If the means of identification of type contains characters not relevant to describe the separate technical unit type covered by this information document, such characters shall be represented in the documentation by the symbol “?” (e.g. ABC??123??).
- (9) Delete where not applicable.