

Regulation (EU) 2018/858 of the European Parliament and of the Council of 30 May 2018 on the approval and market surveillance of motor vehicles and their trailers, and of systems, components and separate technical units intended for such vehicles, amending Regulations (EC) No 715/2007 and (EC) No 595/2009 and repealing Directive 2007/46/EC (Text with EEA relevance)

Changes to legislation: There are currently no known outstanding effects for the Regulation (EU) 2018/858 of the European Parliament and of the Council, ANNEX I. (See end of Document for details)

ANNEX I

GENERAL DEFINITIONS, CRITERIA FOR VEHICLE CATEGORISATION, TYPES OF VEHICLE AND TYPES OF BODYWORK INTRODUCTORY PART *Definitions and general provisions*

1. Definitions

1.1. 'Seating position' means any location capable of accommodating one person seated who is at least as large as:

- (a) the manikin of the 50th percentile adult male in the case of the driver;
- (b) the manikin of the 5th percentile adult female in all other cases.

1.2. 'Seat' means a complete structure with trim, integral or not with the vehicle body structure, which is intended to seat one person.

It includes both an individual seat and a bench seat, as well as folding seats and removable seats.

1.3. 'Goods' means primarily any movable things.

It includes products in bulk, manufactured goods, liquids, living animals, crops, indivisible loads.

1.4. 'Maximum mass' means the 'technically permissible maximum laden mass'.

2. General provisions

2.1. Number of seating positions

2.1.1. The requirements regarding the number of seating positions apply to seats that are designed for use when the vehicle is travelling on the road.

2.1.2. They do not apply to seats that are designed for use when the vehicle is stationary and which are clearly identified to users either by means of a pictogram or a sign with an appropriate text.

2.1.3. The following requirements apply for the counting of the seating positions:

- (a) each individual seat shall be counted as one seating position;
- (b) in the case of a bench seat, any space having a width of at least 400 mm measured at the seat cushion level shall be counted as one seating position.

This condition shall not prevent the manufacturer from using the general provisions referred to in point 1.1;

(c) however, a space as referred to in point (b) shall not be counted as one seating position where:

- (i) the bench seat includes features that prevent the bottom of the manikin from sitting in a natural way - for example: the presence of a fixed console box, an unpadded area or an interior trim interrupting the nominal seating surface;
- (ii) the design of the floor pan located immediately in front of a presumed seating position (for example the presence of a tunnel) prevents the feet of the manikin from being positioned in a natural way.

Changes to legislation: There are currently no known outstanding effects for the Regulation (EU) 2018/858 of the European Parliament and of the Council, ANNEX I. (See end of Document for details)

- 2.1.4. With respect to vehicles covered by UN Regulations No 66 and No 107, the dimension referred to in point 2.1.3(b) shall be aligned with the minimum space required for one person in relation to the various classes of vehicles.
- 2.1.5. When seat anchors for a removable seat are present in a vehicle, the removable seat shall be counted in the determination of the number of the seating positions.
- 2.1.6. An area intended for an occupied wheelchair shall be regarded as one seating position.
- 2.1.6.1. This provision shall be without prejudice to the requirements of paragraphs 3.6.1 and 3.7 of Annex 8 to UN Regulation No 107.
- 2.2. Maximum mass
- 2.2.1. In the case of a tractor unit for semi-trailer, the maximum mass to be considered for classifying the vehicle shall include the maximum mass of the semi-trailer borne by the fifth wheel coupling.
- 2.2.2. In the case of a motor vehicle that can tow a centre-axle trailer or a rigid drawbar trailer, the maximum mass to be considered for classifying the motor vehicle shall include the maximum mass transferred to the towing vehicle by the coupling.
- 2.2.3. In the case of a semi-trailer, a centre-axle trailer and a rigid drawbar trailer, the maximum mass to be considered for classifying the vehicle shall correspond to the maximum mass transmitted to the ground by the wheels of an axle or group of axles when coupled to the towing vehicle.
- 2.2.4. In the case of a converter dolly, the maximum mass to be considered for classifying the vehicle shall include the maximum mass of the semi-trailer borne by the fifth wheel coupling.
- 2.3. Special equipment
- 2.3.1. Vehicles fitted primarily with fixed equipment such as machinery or apparatus shall be regarded as N or O category.
- 2.4. Units
- 2.4.1. Unless otherwise stated any unit of measurement and associated symbol shall conform to ^{F1}the Units of Measurement Regulations 1986].

Textual Amendments

F1 Words in Annex 1 point 2.4.1 substituted (31.12.2022 at 11.00 p.m.) by The Road Vehicles and Non-Road Mobile Machinery (Type-Approval) (Amendment and Transitional Provisions) (EU Exit) Regulations 2022 (S.I. 2022/1273), regs. 1(2), **40(2)**

3. Categorisation into vehicle categories
- 3.1. The manufacturer is responsible for the categorisation of a type of vehicle into a specific category.

For such purposes, all the relevant criteria described in this Annex shall be met.

Changes to legislation: There are currently no known outstanding effects for the Regulation (EU) 2018/858 of the European Parliament and of the Council, ANNEX I. (See end of Document for details)

- 3.2. The approval authority may request from the manufacturer appropriate additional information with the aim of demonstrating that a type of vehicle needs to be categorised as special purpose vehicle in the special group ('SG Code').

PART A

Criteria for vehicle categorisation

1. Vehicle categories

[^{F2}For the purposes of GB type-approval, including GB small series type-approval, and individual vehicle approval], vehicles shall be categorised in accordance with the classification referred to in Article 4.

Textual Amendments

- F2** Words in Annex 1 Pt. A point 1 substituted (31.12.2022 at 11.00 p.m.) by [The Road Vehicles and Non-Road Mobile Machinery \(Type-Approval\) \(Amendment and Transitional Provisions\) \(EU Exit\) Regulations 2022 \(S.I. 2022/1273\)](#), regs. 1(2), **40(3)(a)**

Approval can only be granted for the categories referred to in Article 4(1).

2. Vehicle subcategories

2.1. Off-road vehicles

'Off-road vehicle (ORV)' means a vehicle that belongs to category M or N, having specific technical features which permit its use off the normal roads.

For those categories of vehicles, the letter 'G' shall be added as suffix to the letter and numeral identifying the vehicle category.

The criteria for the subcategorisation of vehicles as ORV are specified in point 4 of this Part.

2.2. Special purpose vehicles (SPV)

- 2.2.1. For incomplete vehicles that are intended to fall into the SPV subcategory, the letter 'S' shall be added as suffix to the letter and numeral identifying the vehicle category.

The various types of special purpose vehicles are defined and listed in point 5.

2.3. Off road special purpose vehicle

- 2.3.1. 'Off road special purpose vehicle (ORV-SPV)' means a vehicle that belongs either to category M or N having the specific technical features referred to in points 2.1 and 2.2.

For those categories of vehicles, the letter 'G' shall be added as suffix to the letter and numeral identifying the vehicle category.

Moreover, for incomplete vehicles that are intended to fall into the SPV subcategory, the letter 'S' shall be added as second suffix.

3. Criteria for the categorisation of vehicles in category N

- 3.1. The categorisation of a type of vehicle in category N shall be based on the technical features of the vehicle as referred to in points 3.2 to 3.6.

- 3.2. As a matter of principle, the compartment(s) where all the seating positions are located, shall be completely separated from the loading area.
- 3.3. By way of derogation from the requirements of point 3.2, persons and goods may be transported in the same compartment under the condition that the loading area is provided with securing devices designed to protect persons transported against the displacement of the load during driving, including severe braking and cornering.
- 3.4. Securing devices - lashing devices - intended for securing the load as required in point 3.3 as well as partitioning systems, intended for vehicles up to 7,5 tonnes shall be designed in accordance with the provisions of sections 3 and 4 of international standard ISO 27956:2009 'Road vehicles – Securing of cargo in delivery vans – Requirements and test methods'.
- 3.4.1. The requirements referred to in point 3.4 may be verified by a statement of compliance provided by the manufacturer.
- 3.4.2. As an alternative to the requirements of point 3.4, the manufacturer may demonstrate to the satisfaction of the approval authority that the securing devices fitted show an equivalent level of protection as provided in the referred standard.
- 3.5. The number of seating positions excluding the driver's seating position shall not exceed:
- (a) 6 in the case of N_1 vehicles;
- (b) 8 in the case of N_2 or N_3 vehicles.
- 3.6. Vehicles shall show a goods-carrying capacity equal or higher than the person-carrying capacity expressed in kg.
- 3.6.1. For such purposes, the following equations shall be satisfied in all configurations, in particular when all seating positions are occupied:
- (a) when $N = 0$:
- $$P - M \geq 100 \text{ kg}$$
- (b) when $0 < N \leq 2$:
- $$P - (M + N \times 68) \geq 150 \text{ kg};$$
- (c) when $N > 2$:
- $$P - (M + N \times 68) \geq N \times 68;$$
- where the letters have the following meaning:
- ‘P’ is the technically permissible maximum laden mass;
- ‘M’ is the mass in running order;
- ‘N’ is the number of seating positions excluding the driver's seating position.
- 3.6.2. The mass of equipment that is fitted to the vehicle in order to accommodate goods (e.g. tank, bodywork, etc.), to handle goods (e.g. crane, lift, etc.) and to secure goods (e.g. cargo securing devices) shall be included in M.
- 3.6.3. The mass of equipment that is not used for the purposes referred to in point 3.6.2 (such as a compressor, a winch, an electric power generator, broadcasting equipment, etc.)

Changes to legislation: There are currently no known outstanding effects for the Regulation (EU) 2018/858 of the European Parliament and of the Council, ANNEX I. (See end of Document for details)

shall not be included in M for the purposes of the application of the formulae referred to in point 3.6.1.

3.7. The requirements referred to in points 3.2 to 3.6 shall be met for all variants and versions within the type of vehicle.

3.8. Criteria for the categorisation of vehicles as N₁.

3.8.1. A vehicle shall be categorised as N₁ when all the applicable criteria are met.

When one or more of the criteria are not met, the vehicle shall be categorised as M₁.

3.8.2. In addition to the general criteria referred to in points 3.2 to 3.6, the criteria specified in this point shall be met for the categorisation of vehicles for which the compartment where the driver is located and the load are within a single unit (i.e. bodywork 'BB').

3.8.2.1. The fact that a wall or a partition, complete or partial, is fitted between a seat row and the cargo area shall not rule out the obligation to meet the required criteria.

3.8.2.2. The criteria shall be as follows:

(a) the loading of the goods shall be possible by a rear door, a tailgate or a side-door designed and constructed for that purposes;

(b) in the case of a rear door or a tailgate, the loading aperture shall meet the following requirements:

(i) in the case the vehicle is fitted with only one row of seats or with only the driver seat, the minimum height of the loading aperture shall be at least 600 mm;

(ii) in the case the vehicle is fitted with two or more rows of seats, the minimum height of the loading aperture shall be at least 800 mm and the aperture shall show a surface of at least 12 800 cm²;

(c) The cargo area shall meet the following requirements:

'cargo area' means the part of the vehicle located behind the row(s) of seats or behind the driver seat when the vehicle is fitted with only one driver seat;

(i) the loading surface of the cargo area shall be generally flat;

(ii) where the vehicle is fitted with only one row of seats or with one seat, the minimum length of the cargo area shall be at least 40 % of the wheelbase;

(iii) where the vehicle is fitted with two or more rows of seats, the minimum length of the cargo area shall be at least 30 % of the wheelbase.

Where the seats of the last row of seats can be easily removed from the vehicle without the use of special tools, the requirements regarding the length of the cargo area shall be met with all the seats installed in the vehicle;

(iv) the requirements regarding the length of the cargo area shall be met when the seats of the first row or of the last row, as the case may be, are upright in their normal position for use by the vehicle occupants.

3.8.2.3. Specific conditions for measurement

3.8.2.3.1. Definitions

- (a) ‘Height of the loading aperture’, means the vertical distance between two horizontal planes tangent respectively to the highest point of the lower part of the doorway and the lowest point of the upper part of the doorway;
- (b) ‘Surface of the loading aperture’ means the greatest surface of the orthogonal projection on a vertical plane, perpendicular to the centreline of the vehicle, of the maximum aperture permitted when the rear door(s) or tailgate is (are) wide open;
- (c) ‘Wheelbase’, for the purposes of application of the formulae in points 3.8.2.2 and 3.8.3.1, means the distance between:
 - (i) the centreline of the front axle and the centreline of the second axle in the case of a two axle vehicle; or
 - (ii) the centreline of the front axle and the centreline of a virtual axle equally distant from the second and third axle in the case of a three axle vehicle.

3.8.2.3.2. Seat adjustments

- (a) The seats shall be adjusted at their rear outermost positions;
- (b) The seat back, if adjustable, shall be adjusted as to accommodate the three-dimensional H-point machine at a torso angle of 25 degrees;
- (c) The seat back, if not adjustable, shall be in the position designed by the vehicle manufacturer;
- (d) When the seat is adjustable in height, it shall be adjusted to its lowest position.

3.8.2.3.3. Vehicle conditions

- (a) The vehicle shall be in loaded conditions corresponding to its maximum mass;
- (b) The vehicle shall be with its wheels straight ahead.

3.8.2.3.4. The requirements of point 3.8.2.3.2 shall not apply when the vehicle is fitted with a wall or a partition.

3.8.2.3.5. Measurement of the length of the cargo area

- (a) When the vehicle is not fitted with a partition or a wall, the length shall be measured from a vertical plane tangent to the rear outermost point of the top of the seat back to the rear internal pane or door or tailgate, in closed position;
- (b) When the vehicle is fitted with a partition or a wall, the length shall be measured from a vertical plane tangent to the rear outermost point of the partition or the wall to the rear internal pane or door or tailgate, as the case may be, in closed position;
- (c) The requirements concerning the length shall be fulfilled at least along a horizontal line situated in the longitudinal vertical plane passing through the centreline of the vehicle, at the level of the load floor.

3.8.3. In addition to the general criteria referred to in points 3.2 to 3.6, the criteria specified in this point shall be met for the categorisation of vehicles for which the compartment where the driver is located and the load are not within a single unit (i.e. bodywork ‘BE’).

3.8.3.1. Where the vehicle is fitted with an enclosure type body, the following shall apply:

Changes to legislation: There are currently no known outstanding effects for the Regulation (EU) 2018/858 of the European Parliament and of the Council, ANNEX I. (See end of Document for details)

- (a) the loading of the goods shall be possible by a rear door, a tailgate or a panel or other means;
 - (b) the minimum height of the loading aperture shall be at least 800 mm and the aperture shall show a surface of at least 12 800 cm²;
 - (c) The minimum length of the cargo area shall be at least 40 % of the wheelbase.
- 3.8.3.2. Where the vehicle is fitted with an open type cargo area, only the provisions referred to in points 3.8.3.1(a) and (c) shall apply.
- 3.8.3.3. For the application of the provisions referred to in point 3.8.3, the definitions in point 3.8.2.3.1 shall apply.
- 3.8.3.4. However, the requirements concerning the length of the cargo area shall be fulfilled along a horizontal line situated in the longitudinal plane passing through the centreline of the vehicle at the level of the load floor.
4. Criteria for the sub-categorisation of vehicles as off-road vehicles
- 4.1. M₁ or N₁ vehicles shall be subcategorised as off-road vehicles if they satisfy at the same time the following conditions:
- (a) at least one front and at least one rear axle designed to be driven simultaneously irrespective of whether one powered axle can be disengaged;
 - (b) at least one differential locking mechanism or a mechanism having similar effect is fitted;
 - (c) they are able to climb at least a 25 % gradient as a solo vehicle;
 - (d) they satisfy five out of the following six requirements:
 - (i) the approach angle shall be at least 25 degrees;
 - (ii) the departure angle shall be at least 20 degrees;
 - (iii) the ramp angle shall be at least 20 degrees;
 - (iv) the ground clearance under the front axle shall be at least 180 mm;
 - (v) the ground clearance under the rear axle shall be at least 180 mm;
 - (vi) the ground clearance between the axles shall be at least 200 mm.
- 4.2. M₂, N₂ or M₃ vehicles the maximum mass of which does not exceed 12 tonnes shall be subcategorised as off-road vehicles if they satisfy either the condition set out in point (a) or the conditions set out in both points (b) and (c):
- (a) all their axles are driven simultaneously, irrespective of whether one or more powered axles can be disengaged;
 - (b)
 - (i) at least one front and at least one rear axle are designed to be driven simultaneously irrespective of whether one powered axle can be disengaged;
 - (ii) at least one differential locking mechanism or a mechanism having the same effect is fitted;
 - (iii) they are able to climb a 25 % gradient as a solo vehicle;

- (c) they satisfy at least five out of the following six requirements if their maximum mass does not exceed 7,5 tonnes and at least four if their maximum mass exceeds 7,5 tonnes:
- (i) the approach angle shall be at least 25 degrees;
 - (ii) the departure angle shall be at least 25 degrees;
 - (iii) the ramp angle shall be at least 25 degrees;
 - (iv) the ground clearance under the front axle shall be at least 250 mm;
 - (v) the ground clearance between axles shall be at least 300 mm;
 - (vi) the ground clearance under the rear axle shall be at least 250 mm.
- 4.3. M₃ or N₃ vehicles whose maximum mass exceeds 12 tonnes shall be subcategorised as off-road vehicles if they satisfy either the condition set out in point (a) or the conditions set out in both points (b) and (c):
- (a) all their axles are driven simultaneously, irrespective of whether one or more powered axles can be disengaged;
- (b)
- (i) at least half of the axles (or two axles out of the three in the case of a three axle vehicle and three axles in the case of a five axle vehicle) is designed to be driven simultaneously, irrespective of whether one powered axle can be disengaged;
 - (ii) there is at least one differential locking mechanism or a mechanism having similar effect;
 - (iii) they are able to climb a 25 % gradient as solo vehicle;
- (c) they satisfy at least four out of the following six requirements:
- (i) the approach angle shall be at least 25 degrees;
 - (ii) the departure angle shall be at least 25 degrees;
 - (iii) the ramp angle shall be at least 25 degrees;
 - (iv) the ground clearance under the front axle shall be at least 250 mm;
 - (v) the ground clearance between axles shall be at least 300 mm;
 - (vi) the ground clearance under the rear axle shall be at least 250 mm.
- 4.4. The procedure for checking compliance with the geometrical provisions referred to in this Part shall be set out in Appendix 1.
- 4.5. The requirements in points 4.1(a), 4.2(a), 4.2(b), 4.3(a), 4.3(b) on simultaneous driven axles are considered to have been fulfilled if one of the following conditions is fulfilled:
- (a) the transmission of the tractive power to all axles is performed by mechanical means only which provides traction in heavy off-road; or
- (b) each of the wheels of the axle in question is driven by an individual hydraulic or electric motor.

Changes to legislation: There are currently no known outstanding effects for the Regulation (EU) 2018/858 of the European Parliament and of the Council, ANNEX I. (See end of Document for details)

If the axles according to the requirements in points 4.1(a), 4.2(a), 4.2(b), 4.3(a), 4.3(b) on simultaneous driven axles are not powered by mechanical means only, the propulsion of the individual wheels shall be designed for heavy off-road operation. In such case it shall be ensured that at least 75 % of total tractive power can be transmitted to the wheel in question when the tractive conditions under the other wheels do not allow to transmit the tractive power properly via these wheels.

The auxiliary drive system according to point 4.5(b) shall not allow to disengage the tractive power automatically until the vehicle reaches 75 % of the maximum vehicle design speed or reaches 65 km/h.

5. Special purpose vehicles

	Name	Code	Definition
5.1.	Motor caravan	SA	A vehicle of category M with living accommodation space which contains the following equipment as a minimum: (a) seats and table; (b) sleeping accommodation which may be converted from the seats; (c) cooking facilities; (d) storage facilities. This equipment shall be rigidly fixed to the living compartment. However, the table may be designed to be easily removable.
5.2.	Armoured vehicle	SB	A vehicle intended for the protection of conveyed persons or goods with anti-bullet armour plating.
5.3.	Ambulance	SC	A vehicle of category M intended for the transport of sick or injured persons and having special equipment for such purpose.

Changes to legislation: There are currently no known outstanding effects for the Regulation (EU) 2018/858 of the European Parliament and of the Council, ANNEX I. (See end of Document for details)

5.4.	Hearse	SD	A vehicle of category M intended for the transport of deceased persons and having special equipment for such purpose.
5.5.	Wheelchair accessible vehicle	SH	A vehicle of category M ₁ constructed or converted specifically so that they accommodate one or more persons seated in their wheelchairs when travelling on the road.
5.6.	Trailer caravan	SE	A vehicle of category O as defined in term 3.2.1.3 of international standard ISO 3833:1977.
5.7.	Mobile crane	SF	A vehicle of category N ₃ , not fitted for the carriage of goods, provided with a crane whose lifting moment is equal to or higher than 400 kNm.
5.8.	Special group	SG	A special purpose vehicle that does not enter in any of the definitions mentioned in this Part.
5.9.	Converter dolly	SJ	A vehicle of category O equipped with a fifth-wheel coupling to support a semi-trailer with a view to converting the latter into a trailer.
5.10.	Exceptional load transport trailer	SK	A vehicle of category O ₄ intended for the transport of indivisible loads that is subject to speed and traffic restrictions because of its dimensions. Under this term are also included

Changes to legislation: There are currently no known outstanding effects for the Regulation (EU) 2018/858 of the European Parliament and of the Council, ANNEX I. (See end of Document for details)

			hydraulic modular trailers irrespective of the number of modules.
5.11.	Exceptional load transport motor vehicle	SL	<p>A road tractor or tractor unit for semi-trailer of category N₃ meeting all the following conditions:</p> <p>(a) having more than two axles and at least half of the axles (two axles out of three in the case of a three axle vehicle and three axles out of five in the case of a five axle vehicle) designed to be driven simultaneously, irrespective of whether one powered axle can be disengaged;</p> <p>(b) that is designed for towing and pushing exceptional load transport trailer of category O₄;</p> <p>(c) that has a minimum engine power of 350 kW; and</p> <p>(d) that can be equipped with an</p>

Changes to legislation: There are currently no known outstanding effects for the Regulation (EU) 2018/858 of the European Parliament and of the Council, ANNEX I. (See end of Document for details)

			additional front coupling device for heavy towable masses.
5.12.	Multi-equipment carrier	SM	<p>An off-road vehicle of category N (as defined in point 2.3) designed and constructed for pulling, pushing, carrying and actuating certain inter-changeable equipment:</p> <p>(a) with not less than two mounting areas for this equipment;</p> <p>(b) with standardised, mechanical, hydraulic and/or electrical interfaces (e.g. Power take off) for powering and actuating the inter-changeable equipment; and</p> <p>(c) that fulfils the definition of international standard ISO 3833-1977, paragraph 3.1.4 (special vehicle).</p> <p>If the vehicle is equipped with</p>

Changes to legislation: There are currently no known outstanding effects for the Regulation (EU) 2018/858 of the European Parliament and of the Council, ANNEX I. (See end of Document for details)

			<p>an auxiliary load platform, its maximum length shall not exceed:</p> <p>(a) 1,4 times of the front or rear track width of the vehicle, whichever is the larger in the case of two axle vehicles; or</p> <p>(b) 2,0 times of the front or rear track width of the vehicle, whichever is the larger in the case of vehicles having more than two axles.</p>
--	--	--	--

6. Remarks

6.1. Type-approval shall not be granted:

- (a) to converter dolly as defined in point 5.9 of this Part;
- (b) to rigid drawbar trailers as defined in point 5.4 of Part C;
- (c) to trailers in which persons may be carried when travelling on the road.

6.2. Point 6.1 is without prejudice to Article 42 on ^{F3}... small series type-approval.

Textual Amendments

F3 Word in Annex 1 Pt. A point 6.2 omitted (31.12.2022 at 11.00 p.m.) by virtue of [The Road Vehicles and Non-Road Mobile Machinery \(Type-Approval\) \(Amendment and Transitional Provisions\) \(EU Exit\) Regulations 2022 \(S.I. 2022/1273\)](#), regs. 1(2), **40(3)(b)**

PART B

Criteria for types of vehicle, variants and versions

1. Category M₁

1.1. Type of vehicle

1.1.1. A ‘type of vehicle’ shall consist of vehicles that have the following features in common:

(a) the manufacturer's company name.

A change in the legal form of ownership of the company does not require that a new approval has to be granted;

(b) the design and assembly of the essential parts of the body structure in the case of a self-supporting body.

The same shall apply to vehicles the bodywork of which is bolted on or welded to a separate frame;

1.1.2. By way of derogation from the requirements of point 1.1.1(b), when the manufacturer uses the floor portion of the body structure as well as the essential constituent elements forming the front part of the body structure located directly in front of the windscreen bay, in the construction of different kinds of bodywork (for example a saloon and a coupe), those vehicles may be considered as belonging to the same type. Evidence thereof shall be provided by the manufacturer.

1.1.3. A type shall consist of at least one variant and one version.

1.2. Variant

1.2.1. A ‘variant’ within a type of vehicle shall group the vehicles that have the following construction features in common:

(a) the number of lateral doors or the type of bodywork as defined in point 2 of Part C when the manufacturer uses the criterion of point 1.1.2;

(b) the power plant with regard to the following construction features:

(i) the type of energy supply (internal combustion engine, electric motor or other);

(ii) the working principle (positive ignition, compression ignition or other);

(iii) the number and arrangement of cylinders in the case of internal combustion engine (L4, V6 or other);

(c) the number of axles;

(d) the number, and interconnection of powered axles;

(e) the number of steered axles;

(f) the stage of completion (e.g. complete/incomplete);

(g) in the case of multi-stage built vehicles, the manufacturer and the type of the previous stage vehicle.

1.3. Version

1.3.1. A ‘version’ within a variant shall group the vehicles that have the following features in common:

(a) the technically permissible maximum laden mass;

Changes to legislation: There are currently no known outstanding effects for the Regulation (EU) 2018/858 of the European Parliament and of the Council, ANNEX I. (See end of Document for details)

- (b) the engine capacity in the case of internal combustion engine;
- (c) the maximum engine power output or the maximum continuous rated power (electric motor);
- (d) the nature of the fuel (petrol, gas oil, LPG, bi-fuel or other);
- (e) the maximum number of seating positions;
- (f) drive-by sound level;
- (g) exhaust emission level (for example Euro 5, Euro 6 or other);
- (h) combined or weighted, combined CO₂ emissions;
- (i) electric energy consumption (weighted, combined);
- (j) combined or weighted, combined fuel consumption;

As an alternative to the criteria in points (h), (i) and (j), the vehicles grouped into a version shall have in common all tests performed for the calculation of their CO₂ emissions, electric energy consumption and fuel consumption in accordance with sub-Annex 6 to Annex XXI to Commission Regulation (EU) 2017/1151⁽⁴⁾.

2. Categories M₂ and M₃

2.1. Type of vehicle

2.1.1. A 'type of vehicle' shall consist of vehicles that have the following features in common:

- (a) the manufacturer's company name.
A change in the legal form of ownership of the company does not require that a new approval has to be granted;
- (b) the category;
- (c) the following aspects of construction and design:
 - (i) the design and construction of the essential constituent elements forming the chassis;
 - (ii) the design and construction of the essential constituent elements forming the body structure in the case of a self-supporting body;
- (d) the number of decks (single or double);
- (e) the number of sections (rigid/articulated);
- (f) the number of axles;
- (g) the mode of energy supply (on-board or off-board);

2.1.2. A type of vehicle shall consist of at least one variant and one version.

2.2. Variant

2.2.1. A 'variant' within a type of vehicle shall group the vehicles that have all of the following construction features in common:

- (a) the type of bodywork as defined in point 3 of Part C;
- (b) the class or combination of classes of vehicles as defined in paragraph 2.1.1 of UN Regulation No 107 (only in the case of complete and completed vehicles);
- (c) the stage of completion (e.g. complete/incomplete/completed);
- (d) the power plant with regard to the following construction features:
 - (i) the type of energy supply (internal combustion engine, electric motor or other);
 - (ii) the working principle (positive ignition, compression ignition or other);
 - (iii) the number and arrangement of cylinders in the case of internal combustion engine (L6, V8 or other);
- (e) in the case of multi-stage built vehicles, the manufacturer and the type of the previous stage vehicle.

2.3. Version

2.3.1. A 'version' within a variant shall group the vehicles that have all the following features in common:

- (a) the technically permissible maximum laden mass;
- (b) the ability of the vehicle to tow a trailer or not;
- (c) the engine capacity in the case of internal combustion engine;
- (d) the maximum engine power output or the maximum continuous rated power (electric motor);
- (e) the nature of the fuel (petrol, gas oil, LPG, bi-fuel or other);
- (f) drive-by sound level;
- (g) exhaust emission level (for example Euro IV, Euro V or other).

3. Category N₁

3.1. Type of vehicle

3.1.1. A 'type of vehicle' shall consist of vehicles that have the following features in common:

- (a) the manufacturer's company name.

A change in the legal form of ownership of the company does not require that a new approval has to be granted;

- (b) the design and assembly of the essential parts of the body structure in the case of a self-supporting body;
- (c) the design and the construction of the essential constituent elements forming the chassis in the case of a non-self-supporting body.

3.1.2. By way of derogation from the requirements of point 3.1.1(b), when the manufacturer uses the floor portion of the body structure as well the essential constituent elements forming the front part of the body structure located directly in front of the windscreen

Changes to legislation: There are currently no known outstanding effects for the Regulation (EU) 2018/858 of the European Parliament and of the Council, ANNEX I. (See end of Document for details)

bay, in the construction of different kinds of bodywork (for example a van and a chassis-cab, different wheelbases and different roof heights), those vehicles may be considered as belonging to the same type. Evidence thereof shall be provided by the manufacturer.

3.1.3. A type of vehicle shall consist of at least one variant and one version.

3.2. Variant

3.2.1. A 'variant' within a type of vehicle shall group the vehicles that have the following construction features in common:

- (a) the number of lateral doors or the type of bodywork as defined in point 4 of Part C (for complete and completed vehicles) when the manufacturer uses the criterion of point 3.1.2;
- (b) the stage of completion (e.g. complete/incomplete/completed);
- (c) the power plant with regard to the following construction features:
 - (i) the type of energy supply (internal combustion engine, electric motor or other);
 - (ii) the working principle (positive ignition, compression ignition or other);
 - (iii) the number and arrangement of cylinders in the case of internal combustion engine (L6, V8 or other);
- (d) the number of axles;
- (e) the number and interconnection of powered axles;
- (f) the number of steered axles.
- (g) in the case of multi-stage built vehicles, the manufacturer and the type of the previous stage vehicle.

3.3. Version

3.3.1. A 'version' within a variant shall group the vehicles that have the following features in common:

- (a) the technically permissible maximum laden mass;
- (b) the engine capacity in the case of internal combustion engine;
- (c) the maximum engine power output or maximum continuous rated power (electric motor);
- (d) the nature of the fuel (petrol, gas oil, LPG, bi-fuel or other);
- (e) the maximum number of seating positions;
- (f) drive-by sound level;
- (g) exhaust emission level (for example Euro 5, Euro 6 or other);
- (h) combined or weighted, combined CO₂ emissions;
- (i) electric energy consumption (weighted, combined);

- (j) combined or weighted, combined fuel consumption;
- (k) the existence of a unique set of innovative technologies, as specified in Article 12 of Regulation (EU) No 510/2011 of the European Parliament and of the Council⁽²⁾.

As an alternative to the criteria in points (h), (i) and (j), the vehicles grouped into a version shall have in common all tests performed for the calculation of their CO₂ emissions, electric energy consumption and fuel consumption in accordance with sub-Annex 6 to Annex XXI of Regulation (EU) 2017/1151.

4. Categories N₂ and N₃

4.1. Type of vehicle

4.1.1. A 'type of vehicle' shall consist of vehicles that have the following features in common:

- (a) the manufacturer's company name.

A change in the legal form of ownership of the company does not require that a new approval has to be granted;

- (b) the category;
- (c) the design and construction of the chassis that are common to a single line of product;
- (d) the number of axles;

4.1.2. A type of vehicle shall consist of at least one variant and one version.

4.2. Variant

4.2.1. A 'variant' within a type of vehicle shall group the vehicles that have the following construction features in common:

- (a) the body structural concept or type of bodywork as defined in point 4 of Part C and in Appendix 2 (only for complete and completed vehicles);
- (b) the stage of completion (e.g. complete/incomplete/completed);
- (c) the power plant with regard to the following construction features:
 - (i) the type of energy supply (internal combustion engine, electric motor or other);
 - (ii) the working principle (positive ignition, compression ignition or other);
 - (iii) the number and arrangement of cylinders in the case of internal combustion engine (L6, V8 or other);

- (d) the number and interconnection of powered axles;
- (e) the number of steered axles;
- (f) in the case of multi-stage built vehicles, the manufacturer and the type of the previous stage vehicle.

4.3. Version

4.3.1. A 'version' within a variant shall group the vehicles that have the following features in common:

Changes to legislation: There are currently no known outstanding effects for the Regulation (EU) 2018/858 of the European Parliament and of the Council, ANNEX I. (See end of Document for details)

- (a) the technically permissible maximum laden mass;
 - (b) the ability or not to tow a trailer as follows:
 - (i) an unbraked trailer;
 - (ii) a trailer with an inertia (or overrun) braking system as defined in paragraph 2.12 of UN Regulation No 13;
 - (iii) a trailer with a continuous or semi-continuous braking system as defined in paragraphs 2.9 and 2.10 of UN Regulation No 13;
 - (iv) a trailer of category O₄ that results in a maximum mass of the combination not exceeding 44 tonnes;
 - (v) a trailer of category O₄ that results in a maximum mass of the combination exceeding 44 tonnes;
 - (c) the engine capacity;
 - (d) the maximum engine power output;
 - (e) the nature of the fuel (petrol, gas oil, LPG, bi-fuel or other);
 - (f) drive-by sound level;
 - (g) exhaust emission level (for example Euro IV, Euro V or other).
5. Categories O₁ and O₂
- 5.1. Type of vehicle
- 5.1.1. A 'type of vehicle' shall consist of vehicles that have the following features in common:
- (a) the manufacturer's company name.
A change in the legal form of ownership of the company does not require that a new approval has to be granted;
 - (b) the category;
 - (c) the concept as defined in point 5 of Part C;
 - (d) the following aspects of construction and design:
 - (i) the design and construction of the essential constituent elements forming the chassis;
 - (ii) the design and construction of the essential constituent elements forming the body structure in the case of a self-supporting body;
 - (e) the number of axles.
- 5.1.2. A type of vehicle shall consist of at least one variant and one version.
- 5.2. Variant
- 5.2.1. A 'variant' within a type of vehicle shall group the vehicles that have the following construction features in common:

- (a) the kind of bodywork as referred to in Appendix 2 (for complete and completed vehicles);
- (b) the stage of completion (e.g. complete/incomplete/completed);
- (c) the type of braking system (e.g. unbraked/inertia/power);
- (d) in the case of multi-stage built vehicles, the manufacturer and the type of the previous stage vehicle.

5.3. Version

5.3.1. A 'version' within a variant shall group the vehicles that have the following features in common:

- (a) the technically permissible maximum laden mass;
- (b) the concept of the suspension (air, steel or rubber suspension, torsion bar or other);
- (c) the concept of the drawbar (triangle, tube or other).

6. Categories O₃ and O₄

6.1. Type of vehicle

6.1.1. A 'type of vehicle' shall consist of vehicles that have the following features in common:

- (a) the manufacturer's company name.
A change in the legal form of ownership of the company does not require that a new approval has to be granted;
- (b) the category;
- (c) the concept of the trailer with relation to the definitions in point 5 of Part C;
- (d) the following aspects of construction and design:
 - (i) the design and construction of the essential constituent elements forming the chassis;
 - (ii) the design and construction of the essential constituent elements forming the body structure in the case of trailers with a self-supporting body;

(e) the number of axles.

6.1.2. A type of vehicle shall consist of at least one variant and one version.

6.2. Variants

6.2.1. A 'variant' within a type of vehicle shall group the vehicles that have the following construction and design features in common:

- (a) the kind of bodywork as referred to in Appendix 2 (for complete and completed vehicles);
- (b) the stage of completion (e.g. complete/incomplete/completed);
- (c) the concept of the suspensions (steel, air or hydraulic suspension);

Changes to legislation: There are currently no known outstanding effects for the Regulation (EU) 2018/858 of the European Parliament and of the Council, ANNEX I. (See end of Document for details)

- (d) the following technical features:
 - (i) the capability or not for the chassis to be extendible;
 - (ii) the deck height (normal, low loader, semi-low loader etc.);
- (e) in the case of multi-stage built vehicles, the manufacturer and the type of the previous stage vehicle.

6.3. Versions

6.3.1. A 'version' within a variant shall group the vehicles that have the following features in common:

- (a) the technically permissible maximum laden mass;
- (b) the subdivisions or combination of subdivisions referred to in [F⁴column 4 of table 6 in Schedule 3 to the Road Vehicles (Authorised Weight) Regulations 1998] into which the axle spacing between two consecutive axles forming a group belongs;
- (c) the definition of the axles in the following respects:
 - (i) lift axles (number and position);
 - (ii) loadable axles (number and position);
 - (iii) steered axle (number and position).

Textual Amendments

F4 Words in Annex 1 Pt. B point 6.3.1(b) substituted (31.12.2022 at 11.00 p.m.) by [The Road Vehicles and Non-Road Mobile Machinery \(Type-Approval\) \(Amendment and Transitional Provisions\) \(EU Exit\) Regulations 2022 \(S.I. 2022/1273\)](#), regs. 1(2), **40(4)**

7. Common requirements for all vehicle categories

7.1. When a vehicle falls into several categories because of its maximum mass or the number of seating positions or both, the manufacturer may select to use the criteria of one or the other vehicle category for the definition of the variants and the versions.

7.1.1. Examples:

- (a) a vehicle 'A' may be type-approved as N₁ (3,5 tonnes) and N₂ (4,2 tonnes) in relation to its maximum mass. In such a case, the parameters mentioned in category N₁ may be used also for the vehicle that falls into category N₂ (or vice-versa);
- (b) a vehicle 'B' may be type-approved as M₁ and M₂ in relation to the number of seating positions (7 + 1 or 10 + 1), the parameters mentioned in category M₁ may be used also for the vehicle that falls into category M₂ (or vice-versa).

7.2. A vehicle of category N may be type-approved against the provisions required for category M₁ or M₂, as the case may be, when it is intended to be converted into a vehicle of that category during the next step of a multi-stage type-approval procedure.

7.2.1. This option shall only be permitted for incomplete vehicles.

Such vehicles shall be identified by a specific variant code given by the manufacturer of the base vehicle.

7.3. Type-, variant- and version designations

- 7.3.1. The manufacturer shall allocate an alphanumeric code to each type of vehicle, variant and version, made up of Roman letters and/or Arabic numerals.

The use of brackets and hyphens is permitted provided they do not replace a letter or a numeral.

- 7.3.2. The whole code shall be designated: Type-Variant-Version or ‘TVV’.
- 7.3.3. The TVV shall clearly and unequivocally identify a unique combination of technical features in relation to the criteria defined in this Part.
- 7.3.4. The same manufacturer may use the same code in order to define a type of vehicle when the latter falls in two or more categories.
- 7.3.5. The same manufacturer shall not use the same code in order to define a type of vehicle for more than one type-approval within the same vehicle category.

7.4. Number of characters for the TVV

- 7.4.1. The number of characters shall not exceed:
- (a) 15 for the code of the type of vehicle;
 - (b) 25 for the code of one variant;
 - (c) 35 for the code of one version.
- 7.4.2. The complete alphanumeric ‘TVV’ shall not contain more than 75 characters.
- 7.4.3. When the TVV is used as a whole, a space shall be left between the type, the variant and the version.

Example of such TVV: 159AF[...space]0054[...space]977K(BE).

PART C

Definitions of types of bodywork

1. General

- 1.1. The type of bodywork as well as the code for bodywork shall be indicated by means of codes.

The list of codes shall apply primarily to complete and completed vehicles.

- 1.2. As regards vehicles of categories M, the type of bodywork shall consist of two letters as specified in points 2 and 3.
- 1.3. As regards vehicles of categories N and O, the type of bodywork shall consist of two letters as referred to in points 4 and 5.
- 1.4. Where necessary (especially for the types of bodywork referred to respectively in points 4.1 and 4.6 and in points 5.1 to 5.4), they shall be supplemented by two digits.
- 1.4.1. The list of digits shall be laid down in Appendix 2.

Changes to legislation: There are currently no known outstanding effects for the Regulation (EU) 2018/858 of the European Parliament and of the Council, ANNEX I. (See end of Document for details)

1.5. For special purpose vehicles, the type of bodywork to be used shall be linked to the category of the vehicle.

2. Vehicles belonging to category M₁

Ref.	Code	Name	Definition
2.1.	AA	Saloon	A vehicle defined in term 3.1.1.1 of international standard ISO 3833:1977, fitted with at least four side windows.
2.2.	AB	Hatchback	A saloon as defined in 2.1 with a hatch at the rear end of the vehicle.
2.3.	AC	Station wagon	A vehicle defined in term 3.1.1.4 of international standard ISO 3833:1977.
2.4.	AD	Coupé	A vehicle defined in term 3.1.1.5 of international standard ISO 3833:1977.
2.5.	AE	Convertible	A vehicle defined in terms No 3.1.1.6 of international standard ISO 3833:1977. However, a convertible may have no door.
2.6.	AF	Multi-purpose vehicle	A vehicle other than AG and those mentioned in AA to AE intended for carrying persons and their luggage or occasionally goods, in a single compartment.
2.7.	AG	Truck station wagon	A vehicle defined in term No 3.1.1.4.1 of international standard ISO 3833:1977. However, the luggage compartment must be completely separated from the passenger compartment.

Changes to legislation: There are currently no known outstanding effects for the Regulation (EU) 2018/858 of the European Parliament and of the Council, ANNEX I. (See end of Document for details)

			In addition, the reference point of the driver's seating position needs not to be at least at 750 mm above the surface supporting the vehicle.
--	--	--	--

3. Vehicles belonging to category M₂ or M₃

Ref.	Code	Name	Definition
3.1.	CA	Single-deck vehicle	A vehicle where the spaces provided for persons are arranged in a single level or in a way that they do not constitute two superimposed levels;
3.2.	CB	Double-deck vehicle	A vehicle defined in paragraph 2.1.6 of UN Regulation No 107;
3.3.	CC	Single-deck articulated vehicle	A vehicle defined in paragraph 2.1.3 of UN Regulation No 107 with a single deck;
3.4.	CD	Double-deck articulated vehicle	A vehicle defined in paragraph 2.1.3.1 of UN Regulation No 107;
3.5.	CE	Low-floor single-deck vehicle	A vehicle defined in paragraph 2.1.4 of UN Regulation No 107 with a single deck;
3.6.	CF	Low-floor double-deck vehicle	A vehicle defined in paragraph 2.1.4 of UN Regulation No 107 with a double deck;
3.7.	CG	Articulated low-floor single-deck vehicle	A vehicle that combines the technical features of points 3.3 and 3.5 of this table;

Changes to legislation: There are currently no known outstanding effects for the Regulation (EU) 2018/858 of the European Parliament and of the Council, ANNEX I. (See end of Document for details)

3.8.	CH	Articulated low-floor double-deck vehicle	A vehicle that combines the technical features of points 3.4 and 3.6 of this table;
3.9.	CI	Open top single deck vehicle	A vehicle with partial roof or without roof;
3.10.	CJ	Open top double deck vehicle	A vehicle without roof over all or part of its upper deck;
3.11.	CX	Bus chassis	An incomplete vehicle with just chassis rails or tube assembly, power train, axles, that is intended to be completed with bodywork, customised to the needs of the transport operator.

4. Motor vehicles of category N₁, N₂ or N₃

Ref.	Code	Name	Definition
4.1.	BA	Lorry	A vehicle that is designed and constructed exclusively or principally for conveying goods. It may also tow a trailer.
4.2.	BB	Van	A lorry with the compartment where the driver is located and cargo area within a single unit.
4.3.	BC	Tractor unit for semi-trailer	A towing vehicle that is designed and constructed exclusively or principally to tow semi-trailers.
4.4.	BD	Road tractor	A towing vehicle that is designed and constructed exclusively to tow

Changes to legislation: There are currently no known outstanding effects for the Regulation (EU) 2018/858 of the European Parliament and of the Council, ANNEX I. (See end of Document for details)

			trailers other than semi-trailers.
4.5.	BE	Pick-up truck	A vehicle of a maximum mass not exceeding 3 500 kg in which the seating positions and the cargo area are not located in a single compartment.
4.6.	BX	Chassis-cab or chassis-cowl	An incomplete vehicle with just a cabin (complete or partial), chassis rails, power train, axles, which is intended to be completed with bodywork, customised to the needs of the transport operator.

5. Vehicles of category O

Ref.	Code	Name	Definition
5.1.	DA	Semi-trailer	A trailer that is designed and constructed to be coupled to a tractor unit or to a converter dolly and to impose a substantial vertical load on the towing vehicle or on the converter dolly. The coupling to be used for a vehicle combination shall consist of a king pin and a fifth wheel.
5.2.	DB	Drawbar trailer	A trailer having at least two axles, of which at least one is a steered axle: (a) equipped with a towing device which can move

Changes to legislation: There are currently no known outstanding effects for the Regulation (EU) 2018/858 of the European Parliament and of the Council, ANNEX I. (See end of Document for details)

			<p>vertically (in relation to the trailer); and that transmits less than 100 daN as a static vertical load to the towing vehicle.</p> <p>(b)</p>
5.3.	DC	Centre-axle trailer	<p>A trailer where the axle(s) is (are) positioned close to the centre of gravity of the vehicle (when uniformly loaded) so that only a small static vertical load, not exceeding 10 % of that corresponding to the maximum mass of the trailer or a load of 1 000 daN (whichever is the lesser) is transmitted to the towing vehicle.</p>
5.4.	DE	Rigid drawbar trailer	<p>A trailer with one axle or one group of axles fitted with a drawbar which transmits a static load not exceeding 4 000 daN to the towing vehicle due to its construction and that does not meet the definition of a centre-axle trailer.</p> <p>The coupling to be used for a vehicle combination shall not consist of a king pin and a fifth wheel.</p>

Appendix 1

Procedure for checking whether a vehicle can be categorised as off-road vehicle

1. General

1.1. For the purposes of classification of a vehicle as off-road vehicle, the procedure described in this Appendix shall apply.

2. Test conditions for geometric measurements

2.1. Vehicles belonging to category M₁ or N₁ shall be in unloaded conditions with a manikin of the 50th percentile male installed on the driver's seat and fitted with coolant fluid, lubricants, fuel, tools, spare-wheel (if fitted as OEM equipment).

The manikin may be replaced by a similar device having the same mass.

2.2. Vehicles other than those referred to in point 2.1 shall be loaded to their technically permissible maximum laden mass.

The distribution of the mass on the axles shall be the one that represents the worst case with respect to compliance with the respective criteria.

2.3. A vehicle representative of the type shall be submitted to the technical service in the conditions specified in point 2.1 or 2.2. The vehicle shall be in a stationary position with its wheels set straight ahead.

The ground on which measurements are made shall be as flat and horizontal (maximum of inclination 0,5 %) as possible.

3. Measurement of approach, departure and ramp angles

3.1. The approach angle shall be measured in accordance with paragraph 6.10 of international standard ISO 612:1978.

3.2. The departure angle shall be measured in accordance with paragraph 6.11 of international standard ISO 612:1978.

3.3. The ramp angle shall be measured in accordance with paragraph 6.9 of international standard ISO 612:1978.

3.4. When measuring the departure angle rear underrun protection devices which are adjustable in height may be set in the upper position.

3.5. The prescription in point 3.4 shall not be construed as an obligation for the base vehicle to be fitted with a rear underrun protection as original equipment. However, the base vehicle manufacturer shall inform the next stage manufacturer that the vehicle has to comply with the requirements on departure angle when fitted with a rear underrun protection.

4. Measurement of ground clearance

4.1. Ground clearance between the axles

4.1.1. 'Ground clearance between the axles' means the shortest distance between the ground plane and the lowest fixed point of the vehicle.

Changes to legislation: There are currently no known outstanding effects for the Regulation (EU) 2018/858 of the European Parliament and of the Council, ANNEX I. (See end of Document for details)

For the application of the definition, the distance between the last axle of a front group of axle and the first axle of a rear group of axle shall be considered.

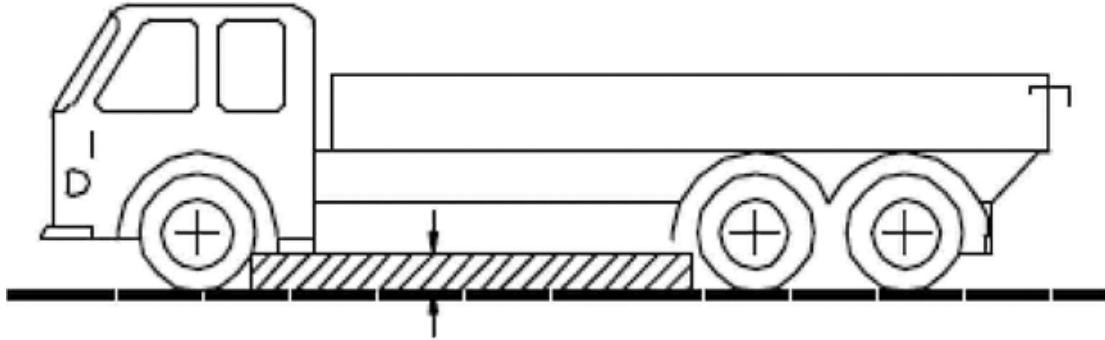

4.1.2. No rigid part of the vehicle may project into the shaded area shown on the figure.

4.2. Ground clearance beneath one axle

4.2.1. 'Ground clearance beneath one axle' means the distance beneath the highest point of the arc of a circle passing through the centre of the tyre footprint of the wheels on one axle (the inner wheels in the case of twin tyres) and touching the lowest fixed point of the vehicle between the wheels.

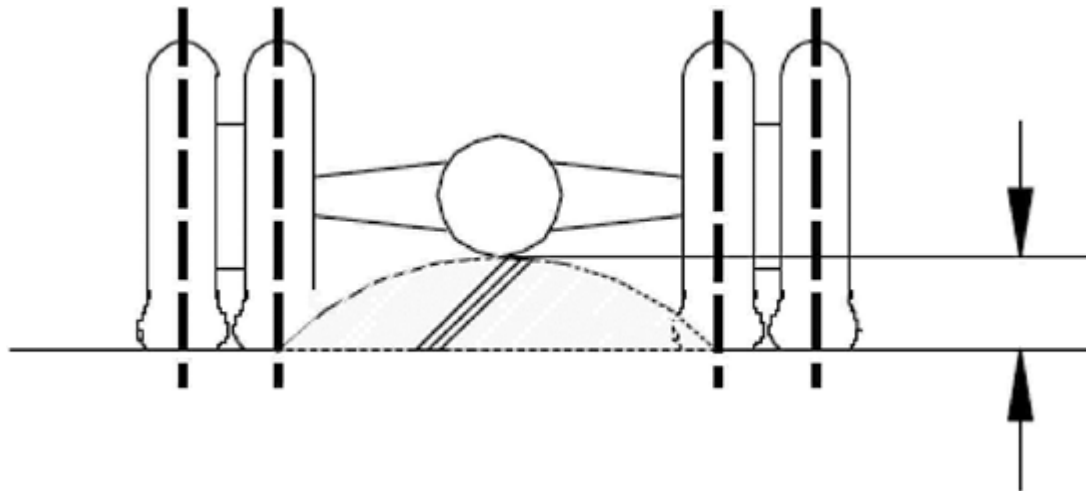

4.2.2. Where appropriate, the measurement of ground clearance shall be conducted on each of the several axles of a group of axles.

5. Gradeability

5.1. 'Gradeability' means the ability of a vehicle to negotiate a gradient.

5.2. To the effect of checking the gradeability of an incomplete and a complete vehicle of category M₂, M₃, N₂ and N₃, a test shall be performed.

5.3. The test shall be conducted by the technical service on a vehicle representative of the type to be tested.

5.4. At the request of the manufacturer and under the conditions specified in Annex VIII, the gradeability of a type of vehicle may be demonstrated by virtual testing.

Changes to legislation: There are currently no known outstanding effects for the Regulation (EU) 2018/858 of the European Parliament and of the Council, ANNEX I. (See end of Document for details)

6. Test conditions and pass-fail criterion
 - 6.1. The conditions set out in Annex II to Commission Regulation (EU) No 1230/2012⁽³⁾ shall apply.
 - 6.2. The vehicle shall climb the gradient at a steady speed without any wheel slipping, longitudinally or laterally.

Changes to legislation: There are currently no known outstanding effects for the Regulation (EU) 2018/858 of the European Parliament and of the Council, ANNEX I. (See end of Document for details)

Appendix 2

Digits used to supplement the codes to be used for various kinds of bodywork

01	Flat bed;
02	Drop-side;
03	Box body;
04	Conditioned body with insulated walls and equipment to maintain the interior temperature;
05	Conditioned body with insulated walls but without equipment to maintain the interior temperature;
06	Curtain-sided;
07	Swap body (interchangeable superstructure);
08	Container carrier;
09	Vehicles fitted with hook lift;
10	Tipper;
11	Tank;
12	Tank intended for transport of dangerous goods;
13	Livestock carrier;
14	Vehicle transporter;
15	Concrete mixer;
16	Concrete pump vehicle;
17	Timber;
18	Refuse collection vehicle;
19	Street sweeper, cleansing and drain clearing;
20	Compressor;
21	Boat carrier;
22	Glider carrier;
23	Vehicles for retail or display purposes;
24	Recovery vehicle;
25	Ladder vehicle;
26	Crane lorry (other than a mobile crane as defined in point 5.7 of Part A);
27	Aerial work platform vehicle;
28	Digger derrick vehicle;
29	Low floor trailer;
30	Glazing transporter;
31	Fire engine;
99	Bodywork that is not included in this list.

Changes to legislation: There are currently no known outstanding effects for the Regulation (EU) 2018/858 of the European Parliament and of the Council, ANNEX I. (See end of Document for details)

- (1) Commission Regulation (EU) 2017/1151 of 1 June 2017 supplementing Regulation (EC) No 715/2007 of the European Parliament and of the Council on type-approval of motor vehicles with respect to emissions from light passenger and commercial vehicles (Euro 5 and Euro 6) and on access to vehicle repair and maintenance information, amending Directive 2007/46/EC of the European Parliament and of the Council, Commission Regulation (EC) No 692/2008 and Commission Regulation (EU) No 1230/2012 and repealing Commission Regulation (EC) No 692/2008 (OJ L 175, 7.7.2017, p. 1).
- (2) Regulation (EU) No 510/2011 of the European Parliament and of the Council of 11 May 2011 setting emission performance standards for new light commercial vehicles as part of the Union's integrated approach to reduce CO₂ emissions from light-duty vehicles (OJ L 145, 31.5.2011, p. 1).
- (3) Commission Regulation (EU) No 1230/2012 of 12 December 2012 implementing Regulation (EC) No 661/2009 of the European Parliament and of the Council with regard to type-approval requirements for masses and dimensions of motor vehicles and their trailers and amending Directive 2007/46/EC of the European Parliament and of the Council (OJ L 353, 21.12.2012, p. 31).

Changes to legislation:

There are currently no known outstanding effects for the Regulation (EU) 2018/858 of the European Parliament and of the Council, ANNEX I.