

Regulation (EU) No 540/2014 of the European Parliament and of the Council of 16 April 2014 on the sound level of motor vehicles and of replacement silencing systems, and amending Directive 2007/46/EC and repealing Directive 70/157/EEC (Text with EEA relevance)

REGULATION (EU) No 540/2014 OF THE
EUROPEAN PARLIAMENT AND OF THE COUNCIL

of 16 April 2014

on the sound level of motor vehicles and of replacement silencing systems,
and amending Directive 2007/46/EC and repealing Directive 70/157/EEC

(Text with EEA relevance)

THE EUROPEAN PARLIAMENT AND THE COUNCIL OF THE EUROPEAN UNION,

Having regard to the Treaty on the Functioning of the European Union, and in particular Article 114 thereof,

Having regard to the proposal from the European Commission,

After transmission of the draft legislative act to the national parliaments,

Having regard to the opinion of the European Economic and Social Committee⁽¹⁾,

Acting in accordance with the ordinary legislative procedure⁽²⁾,

Whereas:

- (1) In accordance with Article 26(2) of the Treaty on the Functioning of the European Union (TFEU), the internal market comprises an area without internal frontiers in which the free movement of goods, persons, services and capital is to be ensured. To that end, a comprehensive EU type-approval system for motor vehicles is in place. The technical requirements for the EU type-approval of motor vehicles and their silencing systems with regard to permissible sound levels should be harmonised to avoid the adoption of requirements that differ from one Member State to another, and to ensure the proper functioning of the internal market while, at the same time, providing for a high level of environmental protection and public safety, a better quality of life and health, and taking account of road vehicles as a significant source of noise in the transport sector.
- (2) EU type-approval requirements already apply in the context of Union law regulating various aspects of the performance of motor vehicles, such as CO₂ emissions from cars and light commercial vehicles, pollutant emissions and safety standards. The technical requirements applicable pursuant to this Regulation should be developed in a way that ensures a consistent approach throughout that Union law, taking into account all relevant noise factors.
- (3) Traffic noise harms health in numerous ways. Protracted noise-related stress can exhaust human physical reserves, disrupt the regulatory capacity of organ functions and

hence limit their effectiveness. Traffic noise is a potential risk factor for the development of medical conditions and incidents such as high blood pressure and heart attacks. The effects of traffic noise should be further researched in the same manner as provided for in Directive 2002/49/EC of the European Parliament and of the Council⁽³⁾.

- (4) Council Directive 70/157/EEC⁽⁴⁾ harmonised the different technical requirements of Member States relating to the permissible sound level of motor vehicles and of their exhaust systems for the purpose of the establishment and operation of the internal market. For the purposes of the proper functioning of the internal market and in order to ensure a uniform and consistent application throughout the Union, it is appropriate to replace that Directive by this Regulation.
- (5) This Regulation constitutes a separate Regulation in the context of the type-approval procedure under Directive 2007/46/EC of the European Parliament and of the Council⁽⁵⁾. Accordingly, Annexes IV, VI and XI to that Directive should be amended.
- (6) Directive 70/157/EEC refers to Regulation No 51 of the United Nations Economic Commission for Europe (UNECE) on noise emissions⁽⁶⁾, which specifies the test method for noise emissions, and to UNECE Regulation No 59 on uniform provisions concerning the approval of replacement silencing systems⁽⁷⁾. As a Contracting Party to the Agreement of UNECE of 20 March 1958 concerning the adoption of uniform technical prescriptions for wheeled vehicles, equipment and parts which can be fitted to and/or be used on wheeled vehicles and the conditions for reciprocal recognition of approvals granted on the basis of these prescriptions⁽⁸⁾, the Union has decided to apply those Regulations.
- (7) Since its adoption, Directive 70/157/EEC has been substantially amended several times. The most recent reduction of sound level limits for motor vehicles, introduced in 1995, did not have the effects expected. Studies showed that the test method used under that Directive no longer reflected real life driving behaviour in urban traffic. In particular, as pointed out in the Green Paper on the Future Noise Policy of 4 November 1996, the contribution of tyre-rolling noise to total noise emissions was underestimated in the test method.
- (8) This Regulation should therefore introduce a different test method from that laid down in Directive 70/157/EEC. The new method should be based on the test method published by the UNECE Working Party on Noise (GRB) in 2007 which incorporated a 2007 version of the standard ISO 362. The results of monitoring of both the old and the new test methods were submitted to the Commission.
- (9) The new test method is considered to be representative for sound levels during normal traffic conditions, but it is less representative for sound levels under worst case conditions. Therefore, it is necessary to lay down in this Regulation additional sound emission provisions. Those provisions should establish preventive requirements intended to cover driving conditions of the vehicle in real traffic outside the type-approval driving cycle and to prevent cycle beating. Those driving conditions are environmentally relevant and it is important to ensure that the sound emission of a vehicle under street-driving conditions does not differ significantly from what can be expected from the type-approval test result for the specific vehicle.

- (10) This Regulation should also further reduce sound level limits. It should take account of the new stricter noise requirements for motor vehicle tyres laid down in Regulation (EC) No 661/2009 of the European Parliament and of the Council⁽⁹⁾. Studies highlighting the annoyance and adverse health effects resulting from road traffic noise and the associated costs and benefits should also be taken into account.
- (11) The overall limit values should be reduced with regard to all noise sources of motor vehicles including the air intake over the power train and the exhaust, taking into account the tyre contribution to noise reduction referred to in Regulation (EC) No 661/2009.
- (12) Chapter III of Regulation (EC) No 765/2008 of the European Parliament and of the Council⁽¹⁰⁾, in accordance with which Member States are required to carry out market surveillance and control products entering the Union market, applies to the products covered by this Regulation.
- (13) Noise is a multifaceted issue with multiple sources and factors that influence the sound perceived by people and the impact of that sound upon them. Vehicle sound levels are partially dependent on the environment in which the vehicles are used, in particular the quality of the road infrastructure, and therefore a more integrated approach is required. Directive 2002/49/EC requires strategic noise maps to be drawn up periodically as regards, inter alia, major roads. The information presented in those maps could form the basis of future research work regarding environmental noise in general, and road surface noise in particular, as well as best practice guides on technological road quality development and a classification of road surface types, if appropriate.
- (14) The Sixth Community Environment Action Programme⁽¹¹⁾ set out the framework for environmental policy-making in the Union for the period 2002-2012. That programme called for actions in the field of noise pollution to substantially reduce the number of people regularly affected by long-term average levels of noise, particularly from traffic.
- (15) Technical measures to reduce the sound level of motor vehicles have to comply with a set of competing requirements, such as those of reducing noise and pollutant emissions and improving safety whilst keeping the vehicle in question as cheap and efficient as possible. In attempting to comply with all those requirements equally and strike a balance between them, the vehicle industry all too often runs up against the limits of what is currently technically feasible. Vehicle designers have repeatedly managed to push those limits back by using new, innovative materials and methods. Union law should set a clear framework for innovation that can be achieved in a realistic timeframe. This Regulation establishes such a framework and thus provides an immediate incentive for innovation in keeping with the needs of society, whilst in no way restricting the economic freedom that is vital to the industry.
- (16) Noise pollution is primarily a local problem, but one which calls for a Union-wide solution. The first step in any sustainable noise emissions policy should be to devise measures to reduce sound levels at source. Since the target of this Regulation is the noise source that motor vehicles represent, and given that that noise source is by definition a mobile one, national measures alone are not sufficient.

- (17) The provision of information on sound emissions to consumers and public authorities has the potential to influence purchasing decisions and accelerate the transition to a quieter vehicle fleet. Accordingly, manufacturers should provide information on sound levels of vehicles at the point of sale and in technical promotional material. A label, comparable to the labels used for information on CO₂ emissions, fuel-consumption and tyre-noise, should inform consumers about the sound emissions of a vehicle. The Commission should undertake an impact assessment on the labelling conditions applicable to air and noise pollution levels and on consumer information. That impact assessment should take into account the different types of vehicles covered by this Regulation (including pure electric vehicles) as well as the effect that such labelling could have on the vehicle industry.
- (18) In order to reduce road traffic noise, public authorities should be able to put in place measures and incentives to encourage the use of quieter vehicles.
- (19) Environmental benefits from hybrid electric and pure electric vehicles have resulted in a substantial reduction of the noise emitted by such vehicles. That reduction has removed an important source of an audible signal that is relied upon by blind and visually impaired pedestrians and cyclists, amongst other road users, to become aware of the approach, presence or departure of those vehicles. As a consequence, industry is developing Acoustic Vehicle Alerting Systems (AVAS) to compensate for this lack of audible signal in hybrid electric and pure electric vehicles. The performance of such AVAS fitted to vehicles should be harmonised. In developing of those AVAS consideration should be given to the overall impact on noise in communities.
- (20) The Commission should examine the potential of active safety systems in more silent vehicles such as hybrid electric and pure electric vehicles in order to better serve the objective of improving the safety of vulnerable road users in urban areas, such as blind, visually impaired and aurally challenged pedestrians, cyclists and children.
- (21) Vehicle sound levels have a direct impact on the quality of life of Union citizens, in particular in urban areas in which there is little or no electric or underground public transport provision or cycling or walking infrastructure. The target of doubling the number of public transport users that the European Parliament set in its resolution of 15 December 2011 on the Roadmap to a Single European Transport Area - Towards a competitive and resource efficient transport system⁽¹²⁾ should also be taken into account. The Commission and the Member States should, in accordance with the subsidiarity principle, promote public transport, walking and cycling, with a view to reducing noise pollution in urban areas.
- (22) A vehicle's sound level is partially dependent on how it is used and how well it is maintained following its purchase. Therefore, steps should be taken to raise public awareness in the Union of the importance of adopting a smooth driving style and keeping within the speed limits in force in each Member State.
- (23) In order to simplify the type-approval legislation of the Union, in line with the 2007 recommendations of the CARS 21 Report, it is appropriate to base this Regulation on

UNECE Regulations No 51, with regard to the test method, and No 59 with regard to replacement silencing systems.

- (24) To enable the Commission to adapt certain requirements of Annexes I, IV, VIII and X to this Regulation to technical progress, the power to adopt acts in accordance with Article 290 TFEU should be delegated to the Commission in respect of the amendment of the provisions in those Annexes related to the test methods and sound levels. It is of particular importance that the Commission carry out appropriate consultations during its preparatory work, including at expert level. The Commission, when preparing and drawing up delegated acts, should ensure a simultaneous, timely and appropriate transmission of relevant documents to the European Parliament and to the Council.
- (25) Since the objective of this Regulation, namely to lay down administrative and technical requirements for the EU type-approval of all new vehicles with regard to their sound level and of replacement silencing systems and components thereof type-approved as separate technical units and intended for those vehicles, cannot be sufficiently achieved by the Member States but can rather, by reason of its scale and effects, be better achieved at Union level, the Union may adopt measures, in accordance with the principle of subsidiarity as set out in Article 5 of the Treaty on European Union. In accordance with the principle of proportionality as set out in that Article, this Regulation does not go beyond what is necessary in order to achieve that objective.
- (26) As a consequence of the application of the new regulatory framework laid down pursuant to this Regulation, Directive 70/157/EEC should be repealed,

HAVE ADOPTED THIS REGULATION:

Article 1

Subject matter

This Regulation establishes the administrative and technical requirements for the EU type-approval of all new vehicles of the categories referred to in Article 2 with regard to their sound level, and of replacement silencing systems and components thereof type-approved as separate technical units designed and constructed for vehicles of categories M₁ and N₁ with a view to facilitating their registration, sale and entry into service within the Union.

Article 2

Scope

This Regulation shall apply to vehicles of categories M₁, M₂, M₃, N₁, N₂ and N₃, as defined in Annex II to Directive 2007/46/EC, and to replacement silencing systems and components thereof type-approved as separate technical units designed and constructed for vehicles of categories M₁ and N₁.

Article 3

Definitions

For the purposes of this Regulation, the definitions laid down in Article 3 of Directive 2007/46/EC apply.

In addition, the following definitions also apply:

- (1) ‘type-approval of a vehicle’ means the procedure referred to in Article 3 of Directive 2007/46/EC with regard to sound levels;
 - (2) ‘vehicle type’ means a category of motor vehicles which do not differ in essential respects such as:
 - (a) for vehicles of categories M_1 , $M_2 \leq 3\,500$ kg, N_1 tested in accordance with point 4.1.2.1 of Annex II:
 - (i) the shape or materials of the bodywork (particularly the engine compartment and its soundproofing);
 - (ii) the type of engine (e.g. positive or compression ignition, two- or four-stroke, reciprocating or rotary piston), number and capacity of cylinders, number and type of carburettors or injection system, arrangement of valves, or the type of electric motor;
 - (iii) rated maximum net power and corresponding engine speed(s); however if the rated maximum power and the corresponding engine speed differs only due to different engine mappings, those vehicles may be regarded as of the same type;
 - (iv) the silencing system;
 - (b) for vehicles of categories $M_2 > 3\,500$ kg, M_3 , N_2 , N_3 tested in accordance with point 4.1.2.2 of Annex II:
 - (i) the shape or materials of the bodywork (particularly the engine compartment and its soundproofing);
 - (ii) the type of engine (e.g. positive or compression ignition, two- or four-stroke, reciprocating or rotary piston), number and capacity of cylinders, type of injection system, arrangement of valves, rated engine speed (S), or the type of electric motor;
 - (iii) vehicles having the same type of engine and/or different overall gear ratios may be regarded as vehicles of the same type.
- However, if the differences in point (b) provide for different target conditions, as described in point 4.1.2.2 of Annex II, those differences shall be regarded as a change of type;
- (3) ‘technically permissible maximum laden mass’ (M) means the maximum mass allocated to a vehicle on the basis of its construction features and its design performance; the technically permissible laden mass of a trailer or of a semi-trailer includes the static mass transferred to the towing vehicle when coupled;

- (4) ‘rated maximum net power’ (P_n) means the engine power expressed in kW and measured by the UNECE method pursuant to UNECE Regulation No 85⁽¹³⁾.
- If the rated maximum net power is reached at several engine speeds, the highest engine speed shall be used;
- (5) ‘standard equipment’ means the basic configuration of a vehicle including all features that are fitted without giving rise to any further specifications on configuration or equipment level but equipped with all the features required under the regulatory acts mentioned in Annex IV or Annex XI to Directive 2007/46/EC;
- (6) ‘mass of the driver’ means a mass rated at 75 kg located at the driver's seating reference point;
- (7) ‘mass of a vehicle in running order’ (m_{ro}) means
- (a) in the case of a motor vehicle:
the mass of the vehicle, with its fuel tank(s) filled to at least 90 % of its or their capacity/ies, including the mass of the driver, the fuel and liquids, fitted with the standard equipment in accordance with the manufacturer's specifications and, where they are fitted, the mass of the bodywork, the cabin, the coupling and the spare wheel(s) as well as the tools;
 - (b) in the case of a trailer:
the mass of the vehicle including the fuel and liquids, fitted with the standard equipment in accordance with the manufacturer's specifications, and, when they are fitted, the mass of the bodywork, additional coupling(s), the spare wheel(s) and the tools;
- (8) ‘rated engine speed’ (S) means the declared engine speed in min^{-1} (rpm) at which the engine develops its rated maximum net power pursuant to UNECE Regulation No 85 or, where the rated maximum net power is reached at several engine speeds, the highest one of those speeds;
- (9) ‘power to mass ratio index’ (PMR) means a numerical quantity calculated in accordance with the formula set out in point 4.1.2.1.1 of Annex II;
- (10) ‘reference point’ means one of the following points:
- (a) in the case of vehicles of categories M_1 and N_1 :
 - (i) for front engine vehicles, the front end of the vehicle;
 - (ii) for mid engine vehicles, the centre of the vehicle;
 - (iii) for rear engine vehicles, the rear end of the vehicle.
 - (b) in the case of vehicles of categories M_2 , M_3 , N_2 and N_3 , the border of the engine closest to the front of the vehicle.
- (11) ‘target acceleration’ means acceleration at a partial throttle condition in urban traffic as derived from statistical investigations;
- (12) ‘engine’ means the power source without detachable accessories;
- (13) ‘reference acceleration’ means the required acceleration during the acceleration test on the test track;

- (14) ‘gear ratio weighting factor’ (k) means a dimensionless numerical quantity used to combine the test results of two gear ratios for the acceleration test and the constant speed test;
- (15) ‘partial power factor’ (k_p) means a numerical quantity with no dimension used for the weighted combination of the test results of the acceleration test and the constant speed test for vehicles;
- (16) ‘pre-acceleration’ means the application of an acceleration control device prior to AA' for the purpose of achieving stable acceleration between AA' and BB' as referred to in Figure 1 of the Appendix to Annex II;
- (17) ‘locked gear ratios’ means the control of transmission such that the transmission gear cannot change during a test;
- (18) ‘silencing system’ means a complete set of components necessary for limiting the noise produced by an engine and its exhaust;
- (19) ‘silencing system of different types’ means silencing systems which significantly differ in respect of at least one of the following:
- (a) trade names or trade marks of their components;
 - (b) the characteristics of the materials constituting their components, except for the coating of those components;
 - (c) the shape or size of their components;
 - (d) the operating principles of at least one of their components;
 - (e) the assembly of their components;
 - (f) the number of exhaust silencing systems or components;
- (20) ‘design family of silencing system or silencing system components’ means a group of silencing systems, or components thereof, in which all of the following characteristics are the same:
- (a) the presence of net gas flow of the exhaust gases through the absorbing fibrous material when in contact with that material;
 - (b) the type of the fibres;
 - (c) where applicable, binder material specifications;
 - (d) average fibre dimensions;
 - (e) minimum bulk material packing density in kg/m^3 ;
 - (f) maximum contact surface between the gas flow and the absorbing material;
- (21) ‘replacement silencing system’ means any part of the silencing system, or components thereof, intended for use on a vehicle, other than a part of the type fitted to the vehicle when submitted for EU type-approval pursuant to this Regulation;
- (22) ‘Acoustic Vehicle Alerting System’ (AVAS) means a system for hybrid electric and pure electric vehicles which provides sound to signal the vehicle's presence to pedestrians and other road users;

- (23) ‘point of sale’ means a location where vehicles are stored and offered for sale to consumers;
- (24) ‘technical promotional material’ means technical manuals, brochures, leaflets and catalogues, whether they appear in printed, electronic or online form, as well as websites, and the purpose of which is to promote vehicles to the general public.

Article 4

General obligations of Member States

1 Subject to the dates of phases of application set out in Annex III to this Regulation and without prejudice to Article 23 of Directive 2007/46/EC, Member States shall refuse, on grounds relating to the permissible sound level, to grant EU type-approval in respect of a type of motor vehicle which does not comply with the requirements of this Regulation.

2 From 1 July 2016, Member States shall refuse, on grounds relating to the permissible sound level, to grant EU type-approval in respect of a type of replacement silencing system, or components thereof, as a separate technical unit which does not comply with the requirements of this Regulation.

Member States shall continue to grant EU type-approval, under the terms of Directive 70/157/EEC, to a replacement silencing system, or components thereof, as a separate technical unit intended for vehicles type-approved before the dates of phases of application set out in Annex III to this Regulation.

3 Subject to the dates of phases of application set out in Annex III to this Regulation, Member States shall, on grounds relating to the permissible sound level, consider certificates of conformity for new vehicles to be no longer valid for the purposes of Article 26 of Directive 2007/46/EC, and shall prohibit the registration, sale and entry into service of such vehicles where such vehicles do not comply with this Regulation.

4 Member States shall permit, on grounds relating to the permissible sound level, the sale and entry into service of a replacement silencing system, or components thereof, as a separate technical unit, if it conforms to a type in respect of which a EU type-approval has been granted in accordance with this Regulation.

Member States shall permit the sale and entry into service of replacement silencing systems, or components thereof, holding an EU type-approval as a separate technical unit under the terms of Directive 70/157/EEC intended for vehicles type-approved before the dates of phases of application set out in Annex III to this Regulation.

Article 5

General obligations of manufacturers

1 Manufacturers shall ensure that vehicles, their engine and their silencing system are designed, constructed and assembled so as to enable such vehicles, when in normal use, to comply with this Regulation, despite the vibration to which such vehicles are inherently subjected.

2 Manufacturers shall ensure that silencing systems are designed, constructed and assembled so as to be able to reasonably resist the corrosive phenomena to which they

are exposed having regard to the conditions of use of vehicles, including regional climate differences.

3 The manufacturer shall be responsible to the approval authority for all aspects of the approval process and for ensuring conformity of production, whether or not the manufacturer is directly involved in all stages of the construction of a vehicle, system, component or separate technical unit.

Article 6

Additional sound emission provisions (ASEP)

1 This Article shall apply to vehicles of categories M₁ and N₁ equipped with an internal combustion engine fitted with original equipment manufacturer silencing systems, as well as to replacement silencing systems intended for such categories of vehicles in accordance with Annex IX.

2 Vehicles and replacement silencing systems shall meet the requirements of Annex VII.

3 Vehicles and replacement silencing systems shall be deemed to comply with the requirements of Annex VII, without further testing, if the manufacturer provides technical documents to the approval authority showing that the difference between the maximum and minimum engine speed of the vehicles at BB' as referred to in Figure 1 of the Appendix to Annex II, for any test condition inside the ASEP control range defined in point 2.3 of Annex VII, with respect to conditions set out in Annex II, does not exceed 0,15 x S.

4 The sound emission of the vehicle or replacement silencing system under typical on-road driving conditions, which are different from those under which the type-approval test set out in Annex II and Annex VII was carried out, shall not deviate from the test result in a significant manner.

5 The manufacturer shall not intentionally alter, adjust, or introduce any mechanical, electrical, thermal, or other device or procedure which is not operational during typical on-road driving conditions solely for the purpose of complying with the sound emission requirements under this Regulation.

6 In the application for type-approval, the manufacturer shall provide a statement, established in accordance with the model set out in the Appendix to Annex VII, that the vehicle type or replacement silencing system to be approved complies with the requirements of this Article.

7 Paragraphs 1 to 6 shall not apply to vehicles of category N₁ if one of the following conditions is met:

- a the engine capacity does not exceed 660 cm³ and the power-to-mass ratio calculated by using the technically permissible maximum laden mass does not exceed 35;
- b the payload is at least 850 kg and the power-to-mass ratio calculated by using the technically permissible maximum laden mass does not exceed 40.

Article 7

Consumer information and labelling

Vehicle manufacturers and distributors shall endeavour to ensure that the sound level of each vehicle in decibels (dB(a)), measured in accordance with this Regulation, is

displayed in a prominent position at the point of sale and in technical promotional material.

In the light of the experience gained in the application of this Regulation, the Commission shall, by 1 July 2018 carry out a comprehensive impact assessment on labelling conditions applicable to air and noise pollution levels and on consumer information. The Commission shall report on the findings of that assessment to the European Parliament and to the Council and, if appropriate, submit a legislative proposal.

Article 8

Acoustic Vehicle Alerting System (AVAS)

Manufacturers shall install AVAS meeting the requirements set out in Annex VIII in new types of hybrid electric and pure electric vehicles by 1 July 2019. Manufacturers shall install AVAS in all new hybrid electric and pure electric vehicles by 1 July 2021. Before those dates, where manufacturers choose to install AVAS in vehicles, they shall ensure that those AVAS comply with the requirements set out in Annex VIII.

The Commission shall be empowered to adopt delegated acts in accordance with Article 10 in order to review Annex VIII and to include more detailed requirements on the performance of AVAS or of active safety systems, taking into account the UNECE work on that issue, by 1 July 2017.

Article 9

Amendment of the annexes

The Commission shall be empowered to adopt delegated acts in accordance with Article 10 to amend Annexes I, IV, VIII and X to adapt them to technical progress.

Article 10

Exercise of the delegation

1 The power to adopt delegated acts is conferred on the Commission subject to the conditions laid down in this Article.

2 The power to adopt delegated acts referred to in the second paragraph of Article 8 and in Article 9 shall be conferred on the Commission for a period of five years from 16 June 2014.

3 The delegation of power referred to in the second paragraph of Article 8 and in Article 9 may be revoked at any time by the European Parliament or by the Council. A decision to revoke shall put an end to the delegation of the power specified in that decision. It shall take effect the day following the publication of the decision in the *Official Journal of the European Union* or at a later date specified therein. It shall not affect the validity of any delegated acts already in force.

4 As soon as it adopts a delegated act, the Commission shall notify it simultaneously to the European Parliament and to the Council.

5 A delegated act adopted pursuant to the second paragraph of Article 8 or to Article 9 shall enter into force only if no objection has been expressed either by the European Parliament or by the Council within a period of two months of notification of that act to the European Parliament and the Council or if, before the expiry of that period, the European Parliament and the Council have both informed the Commission that they will not object. That period shall be extended by two months at the initiative of the European Parliament or of the Council.

Article 11

Revision clause

The Commission shall carry out and publish a detailed study on sound level limits by 1 July 2021. The study shall be based on vehicles meeting the latest regulatory requirements. On the basis of the conclusions of that study, the Commission shall, where appropriate, submit a legislative proposal.

Article 12

Amendments to Directive 2007/46/EC

Annexes IV, VI and XI to Directive 2007/46/EC shall be amended in accordance with Annex XI to this Regulation.

Article 13

Transitional provisions

1 In order to check compliance of the test track as described in point 3.1.1 of Annex II, ISO 10844:1994 may be applied as an alternative to ISO 10844:2011 until 30 June 2019.

2 Vehicles with a serial hybrid drive train, which have a combustion engine with no mechanical coupling to the power train, shall be exempted from the requirements of Article 6 until 30 June 2019.

Article 14

Repeal

1 Without prejudice to the second subparagraph of Article 4(2) and the second subparagraph of Article 4(4), Directive 70/157/EEC is repealed with effect from 1 July 2027.

2 References to the repealed Directive shall be construed as references to this Regulation and shall be read in accordance with the correlation table set out in Annex XII to this Regulation.

Article 15

Entry into force

1 This Regulation shall enter into force on the twentieth day following that of its publication in the *Official Journal of the European Union*.

- 2 It shall apply from 1 July 2016.
- 3 Point 3.1.1 of Annex II shall apply from 1 July 2019.
- 4 Part B of Annex XI shall apply from 1 July 2027.

This Regulation shall be binding in its entirety and directly applicable in all Member States.

Done at Strasbourg, 16 April 2014.

For the European Parliament

The President

M. SCHULZ

For the Council

The President

D. KOURKOULAS

Status: This is the original version (as it was originally adopted).

LIST OF ANNEXES

Annex I	EU type-approval in respect of the sound level of a vehicle type	
	Appendix 1:	Information document
	Appendix 2:	Model EU type-approval certificate
Annex II	Methods and instruments for measuring the noise made by motor vehicles	
	Appendix:	Figures
Annex III	Limit values	
Annex IV	Silencing systems containing acoustically absorbing fibrous materials	
	Appendix:	Figure 1 — Test apparatus for conditioning by pulsation
Annex V	Compressed air noise	
	Appendix:	Figure 1 — Microphone positions for measurement of compressed air noise
Annex VI	Checks on conformity of production for vehicles	
Annex VII	Measuring method to evaluate compliance with the Additional Sound Emission Provisions	
	Appendix:	Model statement of compliance with the Additional Sound Emission Provisions
Annex VIII	Measures concerning the Acoustic Vehicle Alerting System (AVAS)	
Annex IX	EU type-approval in respect of the sound level of silencing systems as separate technical units (replacement silencing systems)	
	Appendix 1:	Information document
	Appendix 2:	Model EU type-approval certificate
	Appendix 3:	Model for the EU type-approval mark
	Appendix 4:	Test apparatus
	Appendix 5:	Measuring points — back pressure
Annex X	Checks on conformity of production for replacement silencing system as a separate technical unit	

Annex XI	Amendments to Directive 2007/46/EC
Annex XII	Correlation table

ANNEX I

EU TYPE-APPROVAL IN RESPECT OF THE SOUND LEVEL OF A VEHICLE TYPE

1. APPLICATION FOR EU TYPE-APPROVAL OF A VEHICLE TYPE
 - 1.1. The application for EU type-approval pursuant to Article 7(1) and (2) of Directive 2007/46/EC of a vehicle type with regard to its sound level shall be submitted by the vehicle manufacturer.
 - 1.2. A model for the information document is contained in Appendix 1.
 - 1.3. A vehicle representative of the type in respect of which type-approval is sought shall be submitted by the vehicle manufacturer to the technical service responsible for the tests. In selecting the vehicle representative of the type, the technical service responsible for the tests shall do so to the satisfaction of the approval authority. Virtual testing methods may be used to aid decision-making during the selection process.
 - 1.4. At the request of the technical service, a specimen of the silencing system and an engine of at least the same cylinder capacity and rated maximum power as that fitted to the vehicle in respect of which type-approval is sought shall also be submitted.
2. MARKINGS
 - 2.1. The exhaust and intake system components, excluding fixing hardware and pipes, shall bear the following markings:
 - 2.1.1. the trade mark or name of the manufacturer of the systems and their components;
 - 2.1.2. the manufacturer's trade description.
 - 2.2. The markings referred to in points 2.1.1 and 2.1.2 shall be clearly legible and indelible, even when the system is fitted to the vehicle.
3. GRANTING OF EU TYPE-APPROVAL OF A VEHICLE TYPE
 - 3.1. If the relevant requirements are satisfied, EU type-approval pursuant to Article 9(3) and, if applicable, Article 10(4) of Directive 2007/46/EC shall be granted.
 - 3.2. A model for the EU type-approval certificate is contained in Appendix 2.
 - 3.3. An approval number in accordance with Annex VII to Directive 2007/46/EC shall be assigned to each vehicle type approved. The same Member State shall not assign the same number to another vehicle type.
 - 3.3.1. If the vehicle type complies with the limit values of Phase 1 in Annex III, Section 3 of the type-approval number shall be followed by the character 'A'. If the vehicle type complies with the limit values of Phase 2 in Annex III, Section 3 of the type-approval number shall be followed by the character 'B'. If the vehicle type complies with the limit values of Phase 3 in Annex III, Section 3 of the type-approval number shall be followed by the character 'C'.

4. AMENDMENTS TO EU TYPE-APPROVALS

In the case of amendments to the type approved pursuant to this Regulation, Articles 13, 14, 15, 16 and Article 17(4) of Directive 2007/46/EC shall apply.

5. CONFORMITY OF PRODUCTION ARRANGEMENTS

5.1. Measures to ensure the conformity of production arrangements shall be taken in accordance with the requirements laid down in Article 12 of Directive 2007/46/EC.

5.2. Special provisions:

5.2.1. The tests laid down in Annex VI to this Regulation shall correspond to those referred to in point 2.3.5 of Annex X to Directive 2007/46/EC.

5.2.2. The frequency of inspections referred to in point 3 of Annex X to Directive 2007/46/EC shall normally be once every two years.

Appendix 1

Information document No ... pursuant to Annex I of Directive 2007/46/EC relating to EU type-approval of a vehicle with respect to the permissible sound level

The following information, if applicable, shall be supplied in triplicate and include a list of contents. Any drawings shall be supplied in appropriate scale and in sufficient detail on size A4 or on a folder of A4 format. Photographs, if any, shall show sufficient detail.

If the systems, components or separate technical units have electronic controls, information concerning their performance shall be supplied.

0. GENERAL
 - 0.1. Make (trade name of manufacturer):
 - 0.2. Type:
 - 0.3. Means of identification of type, if marked on the vehicle ^(b):
 - 0.3.1. Location of that marking:
 - 0.4. Category of vehicle ^(c):
 - 0.5. Company name and address of manufacturer:
 - 0.8. Name(s) and address(es) of assembly plant(s):
 - 0.9. Name and address of the manufacturer's representative (if any):
1. GENERAL CONSTRUCTION CHARACTERISTICS OF THE VEHICLE
 - 1.1. Photographs and/or drawings of a representative vehicle:
 - 1.3. Number of axles and wheels ⁽⁴⁾:
 - 1.3.3. Powered axles (number, position, interconnection):
 - 1.6. Position and arrangement of the engine:
2. MASSES AND DIMENSIONS ^(f) ^(g) ⁽⁷⁾ (IN KG AND MM) (REFER TO DRAWING WHERE APPLICABLE)
 - 2.4. Range of vehicle dimensions (overall):
 - 2.4.1. For chassis without bodywork:
 - 2.4.1.1. Length ^(g5):
 - 2.4.1.2. Width ^(g7):
 - 2.4.2. For chassis with bodywork:
 - 2.4.2.1. Length ^(g5):
 - 2.4.2.2. Width ^(g7):
 - 2.6. Mass in running order ^(h)

- (a) minimum and maximum for each variant:
- (b) mass of each version (a matrix shall be provided):
- 2.8. Technically permissible maximum laden mass stated by the manufacturer ⁽¹⁾ ⁽³⁾:
- 3. POWER PLANT ⁽⁴⁾
 - 3.1. Manufacturer of the engine:
 - 3.1.1. Manufacturer's engine code (as marked on the engine, or other means of identification):
 - 3.2. Internal combustion engine
 - 3.2.1.1. Working principle: positive ignition/compression ignition, cycle four-stroke/two-stroke/rotary ⁽¹⁾
 - 3.2.1.2. Number and arrangement of cylinders:
 - 3.2.1.2.3. Firing order:
 - 3.2.1.3. Engine capacity ^(m): ... cm³
 - 3.2.1.8. Maximum net power ⁽ⁿ⁾: ... kW at ... min⁻¹ (manufacturer's declared value)
 - 3.2.4. Fuel feed
 - 3.2.4.2. By fuel injection (compression ignition only): yes/no ⁽¹⁾
 - 3.2.4.2.2. Working principle: Direct injection/pre-chamber/swirl chamber ⁽¹⁾
 - 3.2.4.2.4. Governor
 - 3.2.4.2.4. Type:
 - 3.2.4.2.4.3. Speed at which cut-off starts under load: ... min⁻¹
 - 3.2.4.3. By fuel injection (positive ignition only): yes/no ⁽¹⁾
 - 3.2.4.3.1. Working principle: Intake manifold (single-/multi-point ⁽¹⁾)/direct injection/other (specify) ⁽¹⁾
 - 3.2.8. Intake system
 - 3.2.8.1. Pressure charger: yes/no ⁽¹⁾
 - 3.2.8.4.2. Air filter, drawings: or
 - 3.2.8.4.2. Make(s):
 - 3.2.8.4.2. Type(s):
 - 3.2.8.4.3. Intake silencer, drawings: or
 - 3.2.8.4.3. Make(s):
 - 3.2.8.4.3. Type(s):
 - 3.2.9. Silencing system

3.2.9.2. Description and/or drawing of the silencing system:

3.2.9.4. Exhaust silencer(s):

Type, marking of exhaust silencer(s):

Where relevant for exterior noise, reducing measures in the engine compartment and on the engine:

3.2.9.5. Location of the exhaust outlet:

3.2.9.6. Exhaust silencer containing fibrous materials:

3.2.12.2.1. Catalytic convertor: yes/no ⁽¹⁾

3.2.12.2.2. Number of catalytic convertors and elements (provide the information below for each separate unit):

3.2.12.2.6. Particulate trap: yes/no ⁽¹⁾

3.3. Electric motor

3.3.1. Type (winding, excitation):

3.3.1.1. Maximum hourly output: ... kW

3.3.1.2. Operating voltage: ... V

3.4. Engines or motors or combinations thereof

3.4.1. Hybrid electric vehicle: yes/no ⁽¹⁾

3.4.2. Category of hybrid electric vehicle: off-vehicle charging/non off-vehicle charging ⁽¹⁾

3.4.3. Operating mode switch: with/without ⁽¹⁾

3.4.3.1. Selectable modes

3.4.3.1.1. Pure electric: yes/no ⁽¹⁾

3.4.3.1.2. Pure fuel consuming: yes/no ⁽¹⁾

3.4.3.1.3. Hybrid modes: yes/no ⁽¹⁾ (if yes, short description):

3.4.5. Electric motor (describe each type of electric motor separately)

3.4.5.1. Make:

3.4.5.2. Type:

3.4.5.4. Maximum power: ... kW

4. TRANSMISSION ^(P)

4.2. Type (mechanical, hydraulic, electric, etc.):

4.6. Gear ratios

Status: This is the original version (as it was originally adopted).

Gear	Internal gearbox ratios(ratios of engine to gearbox output shaft revolutions)	Final drive ratio(s) (ratio of gearbox output shaft to driven wheel revolutions)	Total gear ratios
Maximum for CVT ^a 1 2 3 ... Minimum for CVT ^a Reverse			
a Continuously variable transmission			

4.7. Maximum vehicle design speed (in km/h) ⁽⁴⁾:

6. SUSPENSION

6.6. Tyres and wheels

6.6.1. Tyre/wheel combination(s)

(a) for tyres indicate size designation, load-capacity index and speed category symbol,

(b) for wheels indicate rim size(s) and off-set(s).

6.6.2. Upper and lower limits of rolling radii

6.6.2.1. Axle 1:

6.6.2.2. Axle 2:

6.6.2.3. Axle 3:

6.6.2.4. Axle 4:

etc.

9. BODYWORK

9.1. Type of bodywork using the codes defined in Part C of Annex II to Directive 2007/46/EC:

9.2. Materials used and method of construction:

12. MISCELLANEOUS

12.5. Details of any non-engine devices designed to reduce noise (if not covered by other items):

Date:

Signed:

Position in company:

Appendix 2

Model EU type-approval certificate

(Maximum Format: A4 (210 × 297 mm))

Stamp of approval authority

Communication concerning the

type-approval⁽¹⁴⁾

extension of type-approval⁽¹⁴⁾

refusal of type-approval⁽¹⁴⁾

withdrawal of type-approval⁽¹⁴⁾

of a type of a vehicle with regard to the sound level (Regulation (EU) No 540/2014).

Type-approval number:

Reason for extension:

SECTION I

- 0.1. Make (trade name of manufacturer):
- 0.2. Type:
- 0.3. Means of identification of type if marked on the vehicle⁽¹⁵⁾:
 - 0.3.1. Location of that marking:
- 0.4. Category of vehicle⁽¹⁶⁾:
- 0.5. Company name and address of manufacturer:
- 0.8. Name(s) and address(es) of assembly plant(s):
- 0.9. Name and address of the manufacturer's representative (if any):

SECTION II

1. Additional information (where applicable): See Addendum
2. Technical service responsible for carrying out the tests:
3. Date of test report:
4. Number of test report:
5. Remarks (if any): See Addendum
6. Place:
7. Date:

Status: This is the original version (as it was originally adopted).

8. Signature:

Attachments:	Information package
	Test report (for systems)/Test results (for whole vehicles)

Addendum

to EU type-approval certificate No ...

1. Additional information
 - 1.1. Power plant
 - 1.1.1. Manufacturer of the engine:
 - 1.1.2. Manufacturer's engine code:
 - 1.1.3. Maximum net power (g): ... kW at ... min⁻¹ or maximum continuous rated power (electric motor) ... kW⁽¹⁷⁾
 - 1.1.4. Pressure charger(s), make and type:
 - 1.1.5. Air filter, make and type:
 - 1.1.6. Intake silencer(s), make and type:
 - 1.1.7. Exhaust silencer(s), make and type:
 - 1.1.8. Catalyst(s), make and type:
 - 1.1.9. Particulate trap(s), make and type:
 - 1.2. Transmission
 - 1.2.1. Type (mechanical, hydraulic, electric, etc.):
 - 1.3. Non-engine devices designed to reduce noise:
2. Test results
 - 2.1. Sound level of moving vehicle: ... dB(A)
 - 2.2. Sound level of stationary vehicle: ... dB(A) at ... min⁻¹
 - 2.2.1. Sound level of compressed air, service brake: ... dB(A)
 - 2.2.1. Sound level of compressed air, parking brake: ... dB(A)
 - 2.2.1. Sound level of compressed air, during the pressure regulator actuation: ... dB(A)
 - 2.3. Data to facilitate in-use compliance test of hybrid electric vehicles, where an internal combustion engine cannot operate when the vehicle is stationary
 - 2.3.1. Gear (i) or position of the gear selector chosen for the test:
 - 2.3.2. Position of the operating switch during measurement $L_{wot,(i)}$ (if switch is fitted)
 - 2.3.3. Pre-acceleration length l_{pA} ... m
 - 2.3.4. Vehicle speed at the beginning of the acceleration ... km/h
 - 2.3.5. Sound pressure level $L_{wot,(i)}$... dB(A)
3. Remarks:

ANNEX II

METHODS AND INSTRUMENTS FOR MEASURING THE NOISE MADE BY MOTOR VEHICLES

1. METHODS OF MEASUREMENT

- 1.1. The noise made by the vehicle type submitted for EU type-approval shall be measured by the two methods described in this Annex for the vehicle in motion and for the vehicle when stationary. In the case of a hybrid electric vehicle where an internal combustion engine cannot operate when the vehicle is stationary, the emitted noise shall only be measured in motion.

Vehicles having a technically permissible maximum laden mass exceeding 2800 kg shall be subjected to an additional measurement of the compressed air noise with the vehicle stationary in accordance with the specifications of Annex V, if the corresponding brake equipment is part of the vehicle.

- 1.2. The values measured in accordance with the tests set out in point 1.1 of this Annex shall be entered in the test report and on a form conforming to the model contained in Appendix 2 to Annex I.

2. MEASURING INSTRUMENTS

2.1. Acoustic measurements

The apparatus used for measuring the sound level shall be a precision sound-level meter or equivalent measurement system meeting the requirements of class 1 instruments (inclusive of the recommended windscreen, if used). Those requirements are described in 'IEC 61672-1:2002: Precision sound level meters', second edition, of the International Electrotechnical Commission (IEC).

Measurements shall be carried out using the 'fast' response of the acoustic measurement instrument and the 'A' weighting curve also described in 'IEC 61672-1:2002'. When using a system that includes a periodic monitoring of the A-weighted sound pressure level, a reading shall be made at a time interval not greater than 30 ms (milliseconds).

The instruments shall be maintained and calibrated in accordance with the instructions of the instrument manufacturer.

2.2. Compliance with requirements

Compliance of the acoustic measurement instrumentation shall be verified by the existence of a valid certificate of compliance. A certificate of compliance shall be deemed to be valid if certification of compliance with the standards was conducted within the previous 12-month period for the sound calibration device and within the previous 24-month period for the instrumentation system. All compliance testing shall be conducted by a laboratory, which is authorised to perform calibrations traceable to the appropriate standards.

2.3. Calibration of the entire Acoustic Measurement System for measurement session

At the beginning and at the end of every measurement session, the entire acoustic measurement system shall be checked by means of a sound calibrator that complies with the requirements for sound calibrators of precision class 1 as set out in IEC 60942: 2003. Without any further adjustment the difference between the readings shall be less than or equal to 0,5 dB. If that value is exceeded, the results of the measurements obtained after the previous satisfactory check shall be discarded.

2.4. Instrumentation for speed measurements

The engine speed shall be measured with instrumentation having an accuracy of $\pm 2\%$ or better at the engine speeds required for the measurements being performed.

The road speed of the vehicle shall be measured with instrumentation having an accuracy of at least $\pm 0,5$ km/h, when using continuous measurement devices.

If testing uses independent measurements of speed, this instrumentation shall meet specification limits of at least $\pm 0,2$ km/h.

2.5. Meteorological instrumentation

The meteorological instrumentation used to monitor the environmental conditions during the test shall include the following devices, which meet at least the accuracies listed below:

- temperature measuring device, ± 1 °C;
- wind speed-measuring device, $\pm 1,0$ m/s;
- barometric pressure measuring device, ± 5 hPa;
- a relative humidity measuring device, $\pm 5\%$.

3. CONDITIONS OF MEASUREMENT

3.1. Test Site and ambient conditions

3.1.1. The surface of the test track and the dimensions of the test site shall be in accordance with ISO 10844:2011. The surface of the site shall be free of powdery snow, tall grass, loose soil or cinders. There shall be no obstacle which could affect the sound field within the vicinity of the microphone and the sound source. The observer carrying out the measurements shall so position himself as not to affect the readings of the measuring instrument.

3.1.2. Measurements shall not be made under adverse weather conditions. It shall be ensured that the results are not affected by gusts of wind.

The meteorological instrumentation shall be positioned adjacent to the test area at a height of $1,2\text{ m} \pm 0,02\text{ m}$. The measurements shall be made when the ambient air temperature is between $+5$ °C and $+40$ °C.

The tests shall not be carried out if the wind speed, including gusts, at microphone height exceeds 5 m/s, during the noise measurement interval.

A value representative of temperature, wind speed and direction, relative humidity, and barometric pressure shall be recorded during the noise measurement interval.

Any noise peak which appears to be unrelated to the characteristics of the general sound level of the vehicle shall be ignored in taking the readings.

The background noise shall be measured for a duration of 10 seconds immediately before and after a series of vehicle tests. The measurements shall be made with the same microphones and microphone locations used during the test. The A-weighted maximum noise pressure level shall be reported.

The background noise (including any wind noise) shall be at least 10 dB below the A-weighted noise pressure level produced by the vehicle under test. If the difference between the ambient noise and the measured noise is between 10 and 15 dB(A), the appropriate correction shall be

subtracted from the readings on the noise-level meter in order to calculate the test results, as in the following table:

Difference between ambient noise and noise to be measured dB(A)	10	11	12	13	14	15
Correction dB(A)	0,5	0,4	0,3	0,2	0,1	0,0

3.2. Vehicle

3.2.1. The vehicle tested shall be representative of vehicles to be put on the market and selected by the manufacturer in agreement with the technical service, to comply with the requirements of this Regulation. Measurements shall be made without any trailer, except in the case of non-separable vehicles. At the request of the manufacturer, measurements may be made on vehicles with lift axle(s) in a raised position.

Measurements shall be made on vehicles at the test mass m_t specified in accordance with the following table:

Vehicle Category	Vehicle test mass (m_t)
M ₁	$m_t = m_{r0}$
N ₁	$m_t = m_{r0}$
N ₂ , N ₃	<p>$m_t = 50$ kg per kW rated engine power</p> <p>Extra loading to reach the test mass of the vehicle shall be placed above the driven rear axle(s). The extra loading is limited to 75 % of the technically permissible maximum laden mass allowed for the rear axle. The test mass shall be achieved with a tolerance of ± 5 %.</p> <p>If the centre of gravity of the extra loading cannot be aligned with the centre of the rear axle, the test mass of the vehicle shall not exceed the sum of the front axle and the rear axle load in unladen condition plus the extra loading.</p> <p>The test mass for vehicles with more than two axles shall be the same as for a two-axle vehicle.</p>
M ₂ , M ₃	<p>$m_t = m_{r0}$ — mass of the crew member (if applicable)</p> <p>or, if the tests are carried out on an incomplete vehicle not having bodywork,</p>

$m_t = 50$ kg per kW rated engine power
respectively in compliance with conditions
above (see category N₂, N₃).

- 3.2.2. At the applicant's request, the vehicle of a category M₂, M₃, N₂ or N₃ shall be deemed representative of its completed type if the tests are carried out on an incomplete vehicle not having bodywork. In the test of an incomplete vehicle, all relevant soundproofing materials, panels and noise reduction components and systems shall be fitted on the vehicle as designed by the manufacturer except a part of bodywork which is built at a later stage.

No new test shall be required due to the fitting of a supplement fuel tank or re-location of the original fuel tank on the condition that other parts or structures of the vehicle apparently affecting sound emissions have not been altered.

- 3.2.3. Tyre rolling sound emissions are laid down in Regulation (EC) No 661/2009. The tyres to be used for the test shall be representative for the vehicle and shall be selected by the vehicle manufacturer and recorded in Addendum to Appendix 2 to Annex I to this Regulation. They shall correspond to one of the tyre sizes designated for the vehicle as original equipment. The tyre is or will be commercially available on the market at the same time as the vehicle⁽¹⁸⁾. The tyres shall be inflated to the pressure recommended by the vehicle manufacturer for the test mass of the vehicle. The tyres shall have at least 1,6 mm tread depth.
- 3.2.4. Before the measurements are started, the engine shall be brought to its normal operating conditions.
- 3.2.5. If the vehicle is fitted with more than two-wheel drive, it shall be tested in the drive which is intended for normal road use.
- 3.2.6. If the vehicle is fitted with one or more fans having an automatic actuating mechanism, this system shall not be interfered with during the measurements.
- 3.2.7. If the vehicle is equipped with a silencing system containing fibrous materials, the exhaust system is to be conditioned before the test in accordance with Annex IV.

4. METHODS OF TESTING

4.1. Measurement of noise of vehicles in motion

4.1.1. General test conditions

Two lines, AA' and BB', parallel to line PP' and situated respectively 10 m forward and 10 m rearward of line PP' shall be marked out on the test runway.

At least four measurements shall be made on each side of the vehicle and for each gear. Preliminary measurements may be made for adjustment purposes, but shall be disregarded.

The microphone shall be located at a distance of $7,5 \text{ m} \pm 0,05 \text{ m}$ from the reference line CC' of the track and $1,2 \text{ m} \pm 0,02 \text{ m}$ above the ground.

The reference axis for free field conditions (see IEC 61672-1:2002) shall be horizontal and directed perpendicularly towards the path of the vehicle line CC'.

4.1.2. Specific test conditions for vehicles

4.1.2.1. Vehicles of category M₁, M₂ ≤ 3 500 kg, N₁

The path of the centreline of the vehicle shall follow line CC' as closely as possible throughout the entire test, from the approach to line AA' until the rear of the vehicle passes line BB'. If the vehicle is fitted with more than two-wheel drive, it shall be tested in the drive selection which is intended for normal road use.

If the vehicle is fitted with an auxiliary manual transmission or a multi-gear axle, the position used for normal urban driving shall be used. In all cases, the gear ratios for slow movements, parking or braking shall be excluded.

The test mass of the vehicle shall be that set out in the Table in point 3.2.1.

The test speed v_{test} is 50 km/h ± 1 km/h. The test speed shall be reached when the reference point is at line PP'.

4.1.2.1.1. Power to mass ratio index (PMR)

PMR is calculated using the following formula:

$PMR = (P_n/m_t) \times 1\,000$ where P_n is measured in kW and m_t is measured in kg in accordance with point 3.2.1 of this Annex.

PMR, with no dimension, is used for the calculation of acceleration.

4.1.2.1.2. Calculation of acceleration

Acceleration calculations are applicable to M₁, N₁ and M₂ ≤ 3 500 kg categories only.

All accelerations are calculated using different speeds of the vehicle on the test track. The formulae given are used for the calculation of $a_{\text{wot } i}$, $a_{\text{wot } i+1}$ and $a_{\text{wot test}}$. The speed either at AA' or PP' is defined as the vehicle speed when the reference point passes AA' ($v_{AA'}$) or PP' ($v_{PP'}$). The speed at BB' is defined when the rear of the vehicle passes BB' ($v_{BB'}$). The method used for calculating the acceleration shall be indicated in the test report.

Due to the definition of the reference point for the vehicle, the length of the vehicle (l_{veh}) is considered differently in the formula below. If the reference point is in the front of the vehicle, then $l = l_{\text{veh}}$, mid: $l = 1/2 l_{\text{veh}}$ and rear: $l = 0$.

4.1.2.1.2. The calculation procedure for vehicles with manual transmission, automatic transmission, adaptive transmissions and continuous variable transmissions (CVTs) tested with locked gear ratios is as follows:

$$a_{\text{wot test}} = ((v_{BB'}/3,6)^2 - (v_{AA'}/3,6)^2)/(2*(20+l))$$

$a_{\text{wot test}}$ used in the determination of gear selection shall be the average of the four $a_{\text{wot test}, i}$ during each valid measurement run.

Pre-acceleration may be used. The point of depressing the accelerator before line AA' shall be reported in the test report.

4.1.2.1.2. The calculation procedure for vehicles with automatic transmissions, adaptive transmissions and CVTs tested with non-locked gear ratios is as follows:

$a_{\text{wot test}}$ used in the determination of gear selection shall be the average of the four $a_{\text{wot test}, i}$ during each valid measurement run.

Where devices or measures described in point 4.1.2.1.4.2 can be used to control transmission operation for the purpose of achieving test requirements, $a_{\text{wot test}}$ shall be calculated using the following formula:

$$a_{\text{wot test}} = ((v_{\text{BB}}/3,6)^2 - (v_{\text{AA}}/3,6)^2)/(2*(20+1))$$

Pre-acceleration may be used:

Where devices or measures described in point 4.1.2.1.4.2 are not used, $a_{\text{wot test}}$ shall be calculated using the following formula:

$$a_{\text{wot test PP-BB}} = ((v_{\text{BB}}/3,6)^2 - (v_{\text{PP}}/3,6)^2)/(2*(10+1))$$

$a_{\text{wot test PP-BB}}$: acceleration between point PP and BB

Pre-acceleration shall not be used.

The location of depressing the accelerator shall be where the reference point of the vehicle passes line AA'.

4.1.2.1.2. Target acceleration

The target acceleration a_{urban} defines the typical acceleration in urban traffic and is derived from statistical investigations. It is a function depending on the PMR of a vehicle.

The target acceleration a_{urban} shall be calculated using the following formula:

$$a_{\text{urban}} = 0,63 * \log_{10} (\text{PMR}) - 0,09$$

4.1.2.1.2. Reference acceleration

The reference acceleration $a_{\text{wot ref}}$ defines the required acceleration during the acceleration test on the test track. It is a function depending on the PMR of a vehicle. That function is different for specific vehicle categories.

The reference acceleration $a_{\text{wot ref}}$ shall be calculated using the following formula:

$$a_{\text{wot ref}} = 1,59 * \log_{10} (\text{PMR}) - 1,41 \text{ for } \text{PMR} \geq 25$$

$$a_{\text{wot ref}} = a_{\text{urban}} = 0,63 * \log_{10} (\text{PMR}) - 0,09 \text{ for } \text{PMR} < 25$$

4.1.2.1.3. Partial power factor k_p

The partial power factor k_p (see point 4.1.3.1) is used for the weighted combination of the test results of the acceleration test and the constant speed test for vehicles of category M₁ and N₁.

In cases other than a single gear test, $a_{\text{wot ref}}$ shall be used instead of $a_{\text{wot test}}$ (see point 4.1.3.1).

4.1.2.1.4. Gear ratio selection

The selection of gear ratios for the test depends on their specific acceleration potential a_{wot} under full throttle condition, in accordance with the reference acceleration $a_{\text{wot ref}}$ required for the full throttle acceleration test.

Some vehicles may have different software programs or modes for the transmission (e.g. sporty, winter, adaptive). Where the vehicle has different modes leading to valid accelerations, the vehicle manufacturer shall prove to the satisfaction of the technical service, that the vehicle is tested in the mode which achieves an acceleration closest to $a_{\text{wot ref}}$.

4.1.2.1.4. Vehicles with manual transmissions, automatic transmissions, adaptive transmissions or CVTs tested with locked gear ratios

The following conditions for selection of gear ratios are possible:

- (a) if one specific gear ratio gives an acceleration in a tolerance band of $\pm 5\%$ of the reference acceleration $a_{\text{wot ref}}$, not exceeding $2,0 \text{ m/s}^2$, test with that gear ratio.
- (b) if none of the gear ratios give the required acceleration, then choose a gear ratio i , with an acceleration higher and a gear ratio $i + 1$, with an acceleration lower than the reference acceleration. If the acceleration value in gear ratio i does not exceed $2,0 \text{ m/s}^2$, use both gear ratios for the test. The weighting ratio in relation to the reference acceleration $a_{\text{wot ref}}$ is calculated by:

$$k = (a_{\text{wot ref}} - a_{\text{wot (i+1)}}) / (a_{\text{wot (i)}} - a_{\text{wot (i+1)}})$$

- (c) if the acceleration value of gear ratio i exceeds $2,0 \text{ m/s}^2$, the first gear ratio that gives an acceleration below $2,0 \text{ m/s}^2$ shall be used unless gear ratio $i + 1$ provides an acceleration less than a_{urban} . In this case, two gears, i and $i + 1$ shall be used, including the gear i with the acceleration exceeding $2,0 \text{ m/s}^2$. In other cases, no other gear shall be used. The achieved acceleration $a_{\text{wot test}}$ during the test shall be used for the calculation of the partial power factor k_p instead of $a_{\text{wot ref}}$.
- (d) if the vehicle has a transmission in which there is only one selection for the gear ratio, the acceleration test shall be carried out in this vehicle gear selection. The achieved acceleration is then used for the calculation of the partial power factor k_p instead of $a_{\text{wot ref}}$.
- (e) if rated engine speed is exceeded in a gear ratio before the vehicle passes BB' the next higher gear shall be used.

4.1.2.1.4. Vehicles with automatic transmission, adaptive transmissions and CVTs tested with non-locked gear ratios

The gear selector position for full automatic operation shall be used.

The acceleration value $a_{\text{wot test}}$ shall be calculated as defined in point 4.1.2.1.2.2.

The test may then include a gear change to a lower range and a higher acceleration. A gear change to a higher range and a lower acceleration is not allowed. A gear shifting to a gear ratio which is not used in urban traffic shall be avoided.

Therefore, it shall be permitted to establish and use electronic or mechanical devices, including alternate gear selector positions, to prevent a downshift to a gear ratio which is typically not used at the specified test condition in urban traffic.

The achieved acceleration $a_{\text{wot test}}$ shall be greater or equal to a_{urban} .

If possible, the manufacturer shall take measures to avoid an acceleration value $a_{\text{wot test}}$ greater than $2,0 \text{ m/s}^2$.

The achieved acceleration $a_{\text{wot test}}$ shall then be used for the calculation of the partial power factor k_p (see point 4.1.2.1.3) instead $a_{\text{wot ref}}$.

4.1.2.1.5. Acceleration test

The manufacturer shall define the position of the reference point in front of line AA' of fully depressing the accelerator. The accelerator shall be fully depressed (as rapidly as is practicable) when the reference point of the vehicle reaches the defined point. The accelerator shall be kept in this depressed condition until the rear of the vehicle reaches line BB'. The accelerator shall then be released as rapidly as possible. The point of fully depressing the accelerator shall be reported in the test report. The technical service shall have the possibility of pre-testing.

In the case of articulated vehicles consisting of two non-separable units regarded as a single vehicle, the semi-trailer shall be disregarded in determining when line BB' is crossed.

4.1.2.1.6. Constant speed test

The constant speed test shall be carried out with the same gear(s) specified for the acceleration test and a constant speed of 50 km/h with a tolerance of ± 1 km/h between AA' and BB'. During the constant speed test, the acceleration control shall be positioned to maintain a constant speed between AA' and BB' as specified. If the gear is locked for the acceleration test, the same gear shall be locked for the constant speed test.

The constant speed test is not required for vehicles with a PMR < 25.

4.1.2.2. Vehicles of categories $M_2 > 3\,500$ kg, M_3 , N_2 , N_3

The path of the centreline of the vehicle shall follow line CC' as closely as possible throughout the entire test, from the approach to line AA' until the rear of the vehicle passes line BB'. The test shall be conducted without a trailer or semi-trailer. If a trailer is not readily separable from the towing vehicle, the trailer shall not be taken into consideration when assessing the crossing of line BB'. If the vehicle incorporates equipment such as a concrete mixer, a compressor, etc., this equipment shall not be in operation during the test. The test mass of the vehicle shall be set out in the table set out in point 3.2.1.

Target conditions of category $M_2 > 3\,500$ kg, N_2

When the reference point passes line BB', the engine speed $n_{BB'}$ shall be between 70 % and 74 % of speed S, at which the engine develops its rated maximum power, and the vehicle speed shall be 35 km/h \pm 5 km/h. Between line AA' and line BB' a stable acceleration condition shall be ensured.

Target conditions of category M_3 , N_3 :

When the reference point passes line BB', the engine speed $n_{BB'}$ shall be between 85 % and 89 % of speed S, at which the engine develops its rated maximum power, and the vehicle speed shall be 35 km/h \pm 5 km/h. Between line AA' and line BB' a stable acceleration condition shall be ensured.

4.1.2.2.1. Gear ratio selection

4.1.2.2.1.1. Vehicles with manual transmissions

Stable acceleration conditions shall be ensured. The gear choice shall be determined by the target conditions. If the difference in speed exceeds the given tolerance, then two gears shall be tested, one above and one below the target speed.

If more than one gear fulfils the target conditions, the gear which is closest to 35 km/h shall be used. If no gear fulfils the target condition for v_{test} , two gears shall be tested, one above and one below v_{test} . The target engine speed shall be reached under all conditions.

A stable acceleration condition shall be ensured. If a stable acceleration cannot be ensured in a gear, that gear shall be disregarded.

4.1.2.2.1. Vehicles with automatic transmissions, adaptive transmissions and CVTs

The gear selector position for full automatic operation shall be used. The test may then include a gear change to a lower range and a higher acceleration. A gear change to a higher range and a lower acceleration shall not be permitted. A gear shifting to a gear ratio which is not used in urban traffic, at the specified test condition, shall be avoided. Therefore, it shall be permitted to establish and use electronic or mechanical devices to prevent a downshift to a gear ratio which is typically not used at the specified test condition in urban traffic.

If the vehicle includes a transmission design, which provides only a single gear selection (drive), which limits engine speed during the test, the vehicle shall be tested using only a target vehicle speed. If the vehicle uses an engine and transmission combination that does not comply with the requirements set out in point 4.1.2.2.1.1, the vehicle shall be tested using only the target vehicle speed. The target vehicle speed ($v_{BB'}$) for the test is $= 35 \text{ km/h} \pm 5 \text{ km/h}$. A gear change to a higher range and a lower acceleration is allowed after the reference point of the vehicle passes line PP'. Two tests shall be performed, one with the end speed of $v_{\text{test}} = v_{BB'} + 5 \text{ km/h}$, and one with the end speed of $v_{\text{test}} = v_{BB'} - 5 \text{ km/h}$. The reported sound level shall be the result of the test with the highest engine speed obtained during the test from AA' to BB'.

4.1.2.2.2. Acceleration test

When the reference point of the vehicle reaches the line AA' the accelerator control shall be fully depressed (without operating the automatic downshift to a lower range than normally used in urban driving) and held fully depressed until the rear of the vehicle passes BB', but the reference point shall be at least 5 m behind BB'. The accelerator control shall then be released.

In the case of articulated vehicles consisting of two non-separable units regarded as a single vehicle, the semi-trailer shall be disregarded in determining when line BB' is crossed.

4.1.3. Interpretation of results

The maximum A-weighted sound pressure level indicated during each passage of the vehicle between the two lines AA' and BB' shall be noted. If a noise peak obviously out of character with the general sound pressure level is observed, the measurement shall be discarded. At least four measurements for each test condition shall be made on each side of the vehicle and for each gear ratio. Left and right side may be measured simultaneously or sequentially. The first four valid consecutive measurement results, within 2 dB(A), allowing for the deletion of non valid results (see point 3.1), shall be used for the calculation of the final result for the given side of the vehicle. The results of each side shall be averaged separately. The intermediate result is the higher value of the two averages mathematically rounded to the first decimal place.

The speed measurements at AA', BB', and PP' shall be noted and used in calculations to the first significant digit after the decimal place.

The calculated acceleration $a_{\text{wot test}}$ shall be noted to the second digit after the decimal place.

4.1.3.1. Vehicles of categories M₁, N₁ and M₂ ≤ 3 500 kg

The calculated values for the acceleration test and the constant speed test are given by:

$$L_{\text{wot rep}} = L_{\text{wot}(i+1)} + k * (L_{\text{wot}(i)} - L_{\text{wot}(i+1)})$$

$$L_{\text{crs rep}} = L_{\text{crs}(i+1)} + k * (L_{\text{crs}(i)} - L_{\text{crs}(i+1)})$$

Where $k = (a_{\text{wot ref}} - a_{\text{wot}(i+1)}) / (a_{\text{wot}(i)} - a_{\text{wot}(i+1)})$

In the case of a single gear ratio test, the values are the test result of each test.

The final result is calculated by combining $L_{\text{wot rep}}$ and $L_{\text{crs rep}}$. The equation is:

$$L_{\text{urban}} = L_{\text{wot rep}} - k_p * (L_{\text{wot rep}} - L_{\text{crs rep}})$$

The weighting factor k_p gives the partial power factor for urban driving. In cases other than a single gear test k_p is calculated by:

$$k_p = 1 - (a_{\text{urban}}/a_{\text{wot ref}})$$

If only one gear was specified for the test k_p is given by:

$$k_p = 1 - (a_{\text{urban}}/a_{\text{wot test}})$$

In cases where $a_{\text{wot test}}$ is less than a_{urban} :

$$k_p = 0$$

4.1.3.2. Vehicles of categories $M_2 > 3\,500$ kg, M_3 , N_2 , N_3

When one gear is tested, the final result shall be equal to the intermediate result. When two gears are tested the arithmetic mean of the intermediate results shall be calculated.

4.2. Measurement of noise emitted by stationary vehicles

4.2.1. Sound level in the vicinity of vehicles

The measurement results shall be entered into the test report referred to in the Addendum to Appendix 2 to Annex I.

4.2.2. Acoustic measurements

A precision sound level meter, or equivalent measuring system, as defined in point 2.1 shall be used for the measurements

4.2.3. Test site — local conditions as referred to in Figures 2 and 3a to 3d of the Appendix.

4.2.3.1. In the vicinity of the microphone, there shall be no obstacle that could influence the acoustical field and no person shall remain between the microphone and the noise source. The meter observer shall be positioned so as not to influence the meter reading.

4.2.4. Disturbance sound and wind interference

Readings on the measuring instruments produced by ambient noise and wind shall be at least 10 dB(A) below the sound level to be measured. A suitable windscreen may be fitted to the microphone provided that account is taken of its effect on the sensitivity of the microphone (see point 2.1).

4.2.5. Measuring method

4.2.5.1. Nature and number of measurements

The maximum sound level expressed in A-weighted decibels (dB(A)) shall be measured during the operating period referred to in point 4.2.5.3.2.1.

At least three measurements shall be taken at each measuring point.

4.2.5.2. Positioning and preparation of the vehicle

The vehicle shall be located in the centre part of the test area with the gear selector in the neutral position and the clutch engaged. If the design of the vehicle does not allow this, the vehicle shall be tested in conformity with the manufacturer's prescriptions for stationary engine testing. Before each series of measurements, the engine shall be brought to its normal operating condition, as specified by the manufacturer.

If the vehicle is fitted with a fan or fans having an automatic actuating mechanism, this system shall not be interfered with during the sound level measurements.

The engine hood or compartment cover, if so fitted, shall be closed.

4.2.5.3. Measuring of noise in proximity to the exhaust as referred to in Figure 2 and Figures 3a to 3d of the Appendix.

4.2.5.3.1. Positions of the microphone

4.2.5.3.1.1. The microphone shall be located at a distance of $0,5 \text{ m} \pm 0,01 \text{ m}$ from the reference point of the exhaust pipe defined in Figure 2 and Figures 3a to 3d of the Appendix, and at an angle of $45^\circ (\pm 5^\circ)$ to the flow axis of the pipe termination. The microphone shall be at the height of the reference point, but not less than $0,2 \text{ m}$ from the ground surface. The reference axis of the microphone shall lie in a plane parallel to the ground surface and shall be directed toward the reference point on the exhaust outlet. If two microphone positions are possible, the location farthest laterally from the vehicle longitudinal centreline shall be used. If the flow axis of the exhaust outlet pipe is at 90° to the vehicle longitudinal centreline, the microphone shall be located at the point, which is farthest from the engine.

4.2.5.3.1.1. For vehicles having an exhaust provided with outlets spaced more than $0,3 \text{ m}$ apart, measurements shall be made for each outlet. The highest level shall be recorded.

4.2.5.3.1.1. In the case of an exhaust provided with two or more outlets spaced less than $0,3 \text{ m}$ apart and which are connected to the same silencer, only one measurement shall be made; the microphone position is related to the outlet nearest to one extreme edge of the vehicle or, when such outlet does not exist, to the outlet which is the highest above the ground.

4.2.5.3.1.1. For vehicles with a vertical exhaust (e.g. commercial vehicles) the microphone shall be placed at the height of the exhaust outlet. Its axis shall be vertical and oriented upwards. It shall be placed at a distance of $0,5 \text{ m} \pm 0,01 \text{ m}$ from the exhaust pipe reference point, but never less than $0,2 \text{ m}$ from the side of the vehicle nearest to the exhaust.

4.2.5.3.1.1. For exhaust outlets located under the vehicle body, the microphone shall be located a minimum of $0,2 \text{ m}$ from the nearest part of the vehicle, at a point closest to, but never less than $0,5 \text{ m}$ from the exhaust pipe reference point, and at a height of $0,2 \text{ m}$ above the ground, and not in line with the exhaust flow. If it is not physically possible, the angularity requirement in point 4.2.5.3.1.1 need not be met.

4.2.5.3.1.1. Examples of the position of the microphone, depending on the location of the exhaust pipe, are given in Figures 3a-3d of the Appendix.

4.2.5.3.2. Operating conditions of the engine

4.2.5.3.2.1. Target engine speed

— 75 % of the engine speed S for vehicles with a rated engine speed $\leq 5\,000 \text{ min}^{-1}$

- 3 750 min⁻¹ for vehicles with a rated engine speed above 5 000 min⁻¹ and below 7 500 min⁻¹
- 50 % of the engine speed S for vehicles with a rated engine speed $\geq 7\,500$ min⁻¹.

If the vehicle cannot reach such engine speed, the target engine speed shall be 5 % below the maximum possible engine speed for that stationary test.

4.2.5.3.2. Test procedure

The engine speed shall be gradually increased from idle to the target engine speed, not exceeding a tolerance band of ± 3 % of the target engine speed, and held constant. Then the throttle control shall be rapidly released and the engine speed shall return to idle. The sound level shall be measured during a period of operation consisting of maintaining constant engine speed of 1 second and throughout the entire deceleration period. The maximum sound level meter reading during this period of operation, mathematically rounded to the first decimal place, shall be taken as the test value.

4.2.5.3.2. Test validation

The measurement shall be regarded as valid if the test engine speed does not deviate from the target engine speed by more than ± 3 % for at least 1 second.

4.2.6. Results

At least three measurements for each test position shall be made. The maximum A-weighted sound pressure level indicated during each of the three measurements shall be recorded. The first three valid consecutive measurement results, within 2 dB(A), allowing for the deletion of non valid results (taking into account the specifications of the test site as referred to in point 3.1), shall be used for the determination of the final result for the given measurement position. The maximum sound level, for all measurement positions, and of the three measurement results, shall constitute the final result.

5. Noise from hybrid electric vehicles of categories M₁ in motion, where an internal combustion engine cannot operate when the vehicle is stationary (data reported to facilitate testing of the vehicle in use).
 - 5.1. In order to facilitate in-use compliance testing of hybrid electric vehicles — where an internal combustion engine cannot operate when the vehicle is stationary — the following information relating to the sound-pressure level measurements carried out in accordance with point 4.1 of Annex II for the motor vehicles in motion is referred to as in-use compliance reference data:
 - (a) gear (i) or, for vehicles tested with non-locked gear ratios, the position of the gear selector chosen for the test;
 - (b) position of the operating switch during measurement of the sound pressure level $L_{wot,(i)}$ (if switch is fitted).
 - (c) pre-acceleration length l_{PA} in m;
 - (d) average vehicle speed in km/h at the beginning of the full throttle acceleration for tests in gear (i); and
 - (e) sound pressure level $L_{wot,(i)}$ in dB(A) of the wide-open-throttle tests in gear (i), defined as the maximum of the two values resulting from averaging the individual measurement results at each microphone position separately.

Status: This is the original version (as it was originally adopted).

- 5.2. The in-use compliance reference data shall be entered in the EU type-approval certificate as specified in point 2.3 of the Addendum to Appendix 2 to Annex I.

Appendix

Figures

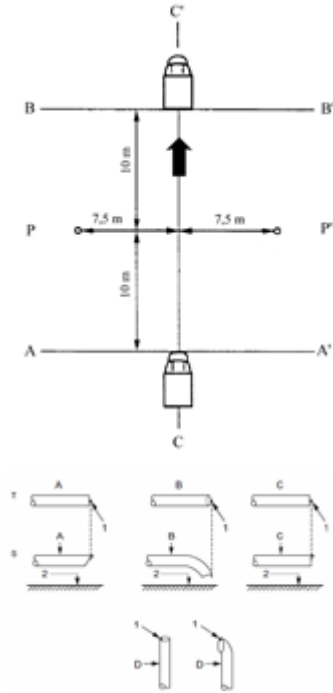

- | | |
|---|-------------------|
| T | = top view |
| S | = side view |
| A | = metered pipe |
| B | = bent down pipe |
| C | = straight pipe |
| D | = vertical pipe |
| 1 | = reference point |
| 2 | = road surface |

Status: This is the original version (as it was originally adopted).

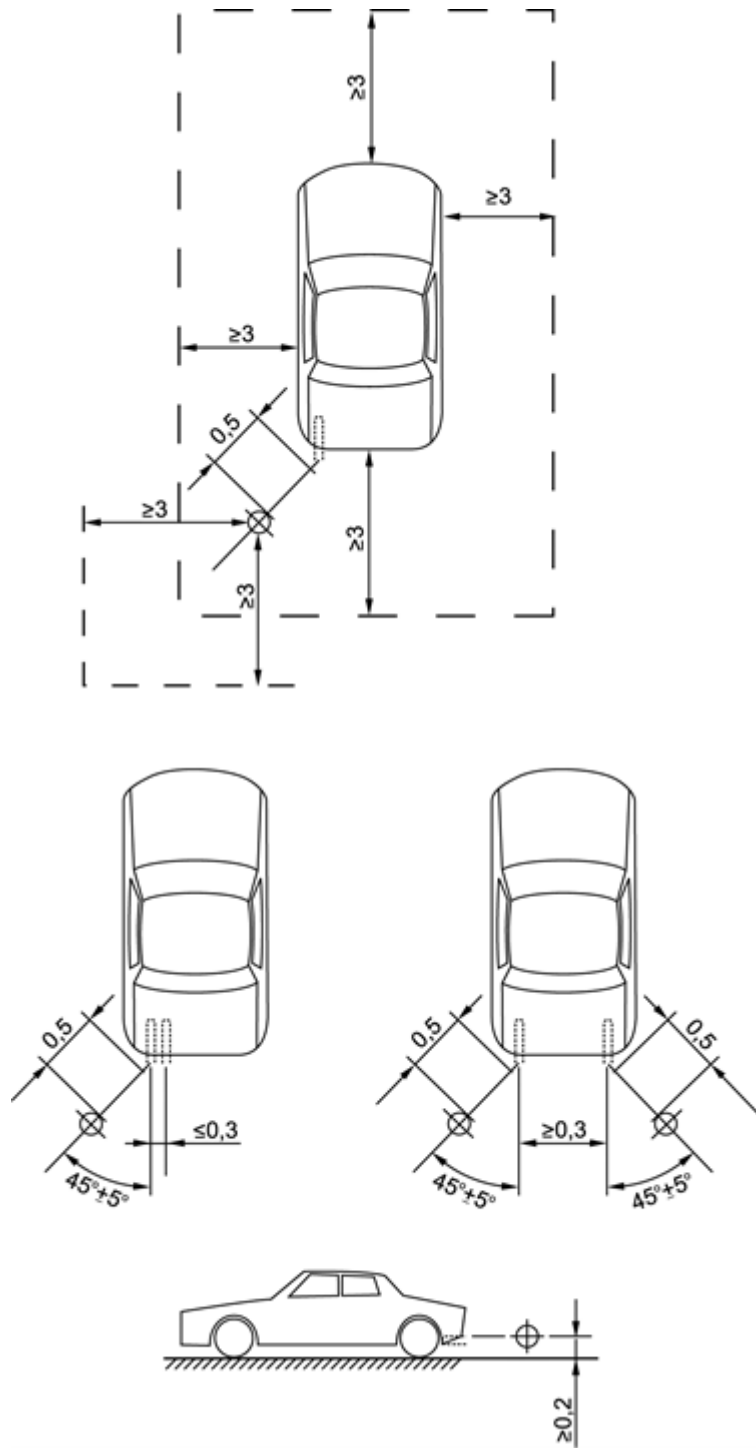

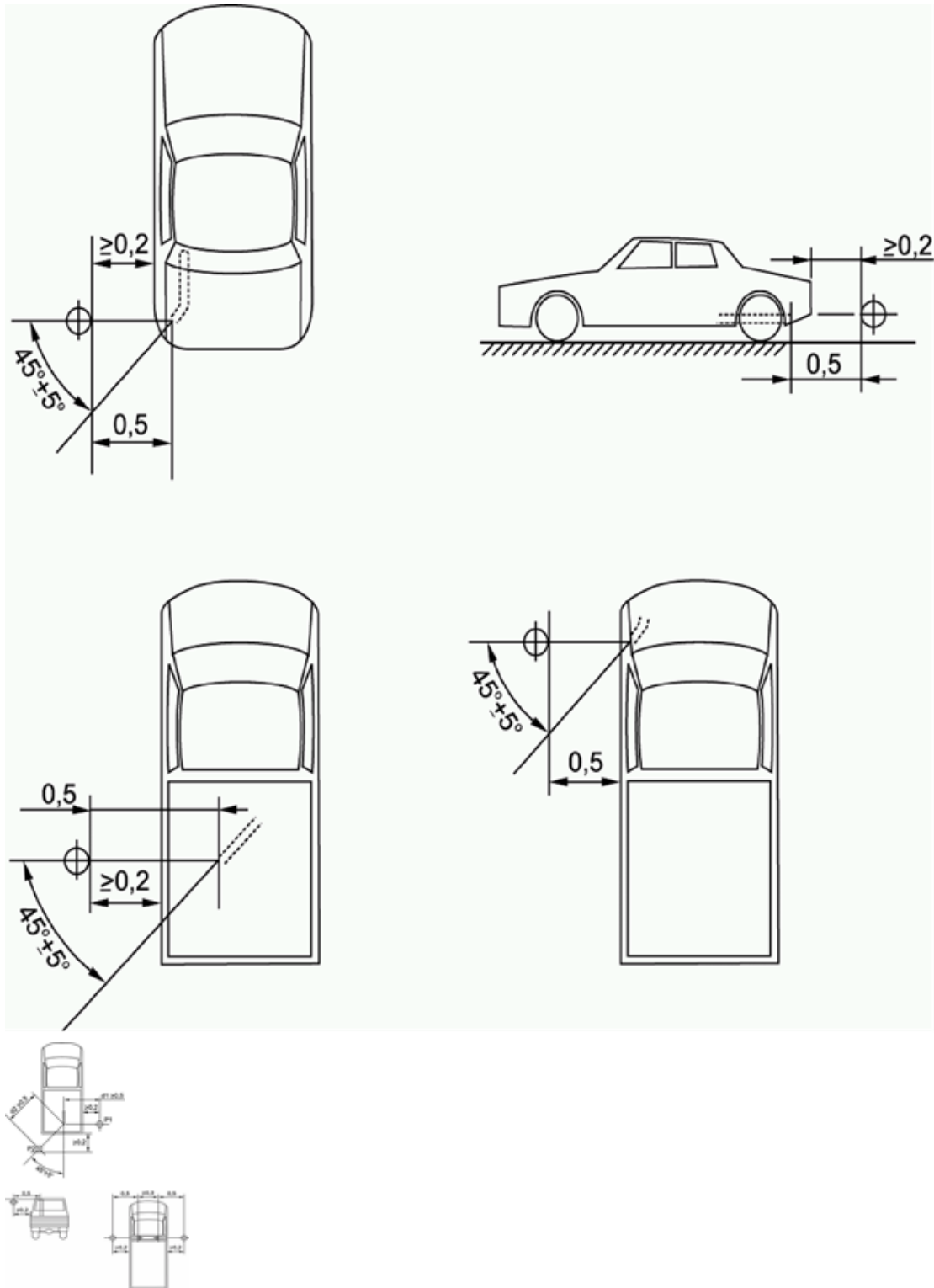

Figures 3 a — d : Examples of the position of the microphone, depending on the location of the exhaust pipe

Status: This is the original version (as it was originally adopted).

ANNEX III

LIMIT VALUES

The sound level measured in accordance with the provisions of Annex II, mathematically rounded to the nearest integer value, shall not exceed the following limits:

Vehicle category	Description of vehicle category	Limit values expressed in dB(A)[decibels (A)]		
		Phase 1 applicable for new vehicle types from 1 July 2016	Phase 2 applicable for new vehicle type from 1 July 2020 and for first registration from 1 July 2022	Phase 3 applicable for new vehicle type from 1 July 2024 and for first registration from 1 July 2026
M	Vehicles used for the carriage of passengers			
M ₁	power to mass ratio ≤ 120 kW/1 000 kg	72 ^a	70 ^a	68 ^a
M ₁	120 kW/1 000 kg < power to mass ratio ≤ 160 kW/1 000 kg	73	71	69
M ₁	160 kW/1 000 kg < power to mass ratio	75	73	71
M ₁	power to mass ratio > 200 kW/1 000 kg number of seats ≤ 4	75	74	72

a M₁ vehicles derived from N₁ vehicles:
M₁ vehicles with an R point > 850 mm from the ground and a total permissible laden mass more than 2 500 kg have to fulfil the limit values of N₁ (2 500 kg < mass ≤ 3 500 kg).

b + two years for new vehicle type and + one year for new vehicles registration.

Limit values shall be increased by 1dB (2 dB(A) for N₃ and M₃ categories) for vehicles that meet the relevant definition for off-road vehicles set out in point 4 of Part A of Annex II to Directive 2007/46/EC.

For M₁ vehicles the increased limit values for off-road vehicles are only valid if the technically permissible maximum laden mass > 2 tonnes.

Limit values shall be increased by 2 db(A) for wheelchair accessible vehicles and armoured vehicles, as defined in Annex II to Directive 2007/46/EC.

Status: This is the original version (as it was originally adopted).

	R point of driver seat \leq 450 mm from the ground			
M ₂	mass \leq 2 500 kg	72	70	69
M ₂	2500 kg < mass \leq 3 500 kg	74	72	71
M ₂	3500 kg < mass \leq 5 000 kg; rated engine power \leq 135 kW	75	73	72
M ₂	3500 kg < mass \leq 5 000 kg; rated engine power > 135 kW	75	74	72
M ₃	rated engine power \leq 150 kW	76	74	73 ^b
M ₃	150 kW < rated engine power \leq 250 kW	78	77	76 ^b
M ₃	rated engine power > 250 kW	80	78	77 ^b
N	Vehicles used for the carriage of goods			
N ₁	mass \leq 2 500 kg	72	71	69
N ₁	2 500 kg < mass \leq 3 500 kg	74	73	71
N ₂	rated engine power \leq 135 kW	77	75 ^b	74 ^b
N ₂	rated engine power > 135 kW	78	76 ^b	75 ^b
N ₃	rated engine power \leq 150 kW	79	77	76 ^b

a M₁ vehicles derived from N₁ vehicles:
M₁ vehicles with an R point > 850 mm from the ground and a total permissible laden mass more than 2 500 kg have to fulfil the limit values of N₁ (2 500 kg < mass \leq 3 500 kg).

b + two years for new vehicle type and + one year for new vehicles registration.

Limit values shall be increased by 1dB (2 dB(A) for N₃ and M₃ categories) for vehicles that meet the relevant definition for off-road vehicles set out in point 4 of Part A of Annex II to Directive 2007/46/EC.

For M₁ vehicles the increased limit values for off-road vehicles are only valid if the technically permissible maximum laden mass > 2 tonnes.

Limit values shall be increased by 2 dB(A) for wheelchair accessible vehicles and armoured vehicles, as defined in Annex II to Directive 2007/46/EC.

Status: This is the original version (as it was originally adopted).

N ₃	150 kW < rated engine power ≤ 250 kW	81	79	77 ^b
N ₃	rated engine power > 250 kW	82	81	79 ^b

a M₁ vehicles derived from N₁ vehicles:
M₁ vehicles with an R point > 850 mm from the ground and a total permissible laden mass more than 2 500 kg have to fulfil the limit values of N₁ (2 500 kg < mass ≤ 3 500 kg).

b + two years for new vehicle type and + one year for new vehicles registration.

Limit values shall be increased by 1dB (2 dB(A) for N₃ and M₃ categories) for vehicles that meet the relevant definition for off-road vehicles set out in point 4 of Part A of Annex II to Directive 2007/46/EC.

For M₁ vehicles the increased limit values for off-road vehicles are only valid if the technically permissible maximum laden mass > 2 tonnes.

Limit values shall be increased by 2 db(A) for wheelchair accessible vehicles and armoured vehicles, as defined in Annex II to Directive 2007/46/EC.

ANNEX IV

SILENCING SYSTEMS CONTAINING ACOUSTICALLY ABSORBING FIBROUS MATERIALS

1. GENERAL

Sound absorbing fibrous materials may be used in silencing systems, or components thereof, where either of the following conditions are fulfilled:

- (a) the exhaust gas is not in contact with the fibrous materials; or
- (b) the silencing system, or components thereof, are of the same design family as systems or components for which it has been proven, in the course of EU type-approval process in accordance with the requirements of this Regulation for another vehicle-type, that they are not subject to deterioration.

Where neither the condition in point (a) nor in point (b) of the first subparagraph is fulfilled, the complete silencing system, or components thereof, shall be submitted to a conventional conditioning using one of three installations and procedures described in points 1.1, 1.2 and 1.3.

For the purposes of point (b) of the first subparagraph, a group of silencing system, or components thereof, shall be considered as being of the same design family when all of the following characteristics are the same:

- (a) the presence of net gas flow of the exhaust gases through the absorbing fibrous material when in contact with that material;
- (b) the type of the fibres;
- (c) where applicable, binder material specifications;
- (d) average fibre dimensions;
- (e) minimum bulk material packing density in kg/m³;
- (f) maximum contact surface between the gas flow and the absorbing material.

- 1.1. Continuous road operation for 10 000 km.
 - 1.1.1. 50 ± 20 % of this operation shall consist of urban driving and the remaining operation shall be long-distance runs at high speed; continuous road operation may be replaced by a corresponding test-track programme.
 - 1.1.2. The two speed regimes shall be alternated at least twice.
 - 1.1.3. The complete test programme shall include a minimum of 10 breaks of at least three hours duration in order to reproduce the effects of cooling and any condensation which may occur.
- 1.2. Conditioning on a test bench
 - 1.2.1. Using standard parts and observing the vehicle manufacturer's instructions, the silencing system, or components thereof, shall be fitted to the vehicle referred to in point 1.3 of Annex I or the engine referred to in point 1.4 of Annex I. In the case of the vehicle referred to in point 1.3 of Annex I, the vehicle shall be mounted on a roller dynamometer. In the case of an engine referred to in point 1.4 of Annex I, the engine shall be coupled to a dynamometer.
 - 1.2.2. The test shall be conducted in six six-hour periods with a break of at least 12 hours between each period in order to reproduce the effects of cooling and any condensation which may occur.
 - 1.2.3. During each six-hour period, the engine shall be run, under the following conditions in turn:
 - (a) five minutes at idling speed;
 - (b) one-hour sequence under 1/4 load at 3/4 of rated maximum speed (S);
 - (c) one-hour sequence under 1/2 load at 3/4 of rated maximum speed (S);
 - (d) 10-minute sequence under full load at 3/4 of rated maximum speed (S);
 - (e) 15-minute sequence under 1/2 load at rated maximum speed (S);
 - (f) 30-minute sequence under 1/4 load at rated maximum speed (S).

Total duration of the six sequences: three hours.

Each period shall comprise two sequenced sets of those conditions in consecutive order from (a) to (f).

- 1.2.4. During the test, the silencing system, or components thereof, shall not be cooled by a forced draught simulating normal airflow around the vehicle. Nevertheless, at the request of the manufacturer, the silencing system or components thereof may be cooled in order not to exceed the temperature recorded at its inlet when the vehicle is running at maximum speed.
- 1.3. Conditioning by pulsation
 - 1.3.1. The silencing system or components thereof shall be fitted to the vehicle referred to in point 1.3 of Annex I or the engine referred to in point 1.4 of Annex I. In the former case the vehicle shall be mounted on a roller dynamometer.

In the second case, the engine shall be mounted on a dynamometer. The test apparatus, a detailed diagram of which is shown in Figure 1 of the Appendix to this Annex shall be fitted at the outlet of the silencing system. Any other apparatus providing equivalent results shall be acceptable.

- 1.3.2. The test apparatus shall be adjusted in such a way that the exhaust-gas flow is alternatively interrupted and re-established by the quick-action valve for 2 500 cycles.
- 1.3.3. The valve shall open when the exhaust-gas back pressure, measured at least 100 mm downstream of the intake flange, reaches a value of between 0,35 and 0,40 kPa. It shall close when this pressure does not differ by more than 10 % from its stabilized value with the valve open.
- 1.3.4. The time-delay switch shall be set for the duration of gas exhaust resulting from the provisions laid down in point 1.3.3.
- 1.3.5. Engine speed shall be 75 % of the speed (S) at which the engine develops maximum power.
- 1.3.6. The power indicated by the dynamometer shall be 50 % of the full-throttle power measured at 75 % of engine speed (S).
- 1.3.7. Any drain holes shall be closed off during the test.
- 1.3.8. The entire test shall be completed within 48 hours.

If necessary, one cooling period shall be observed after each hour.

Appendix

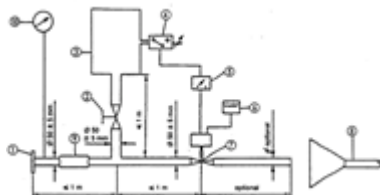

ANNEX V

COMPRESSED AIR NOISE

1. METHOD OF MEASUREMENT

The measurement is performed at microphone positions 2 and 6 as shown in Figure 1 of the Appendix, with the vehicle stationary. The highest A-weighted sound level shall be registered during venting the pressure regulator and during ventilating after the use of both the service and parking brakes.

The noise during venting the pressure regulator is measured with the engine at idling speed. The ventilating noise is registered while operating the service and parking brakes; before each measurement, the air-compressor unit has to be brought up to the highest permissible operating pressure, and then the engine switched off.

2. EVALUATION OF THE RESULTS

For all microphone positions two measurements are taken. In order to compensate for inaccuracies of the measuring equipment, the metre reading is reduced by 1 dB(A), and the reduced value is taken as the result of measurement. The results are taken as valid if the difference between the measurements at one microphone position does not exceed 2 dB(A). The highest value measured is taken as the result. If this value exceeds the sound level limit by 1 dB(A), two additional measurements are to be taken at the corresponding microphone position. In this case, three out of the four results of measurement obtained at this position have to comply with the sound level limit.

3. LIMITING VALUE

The sound level shall not exceed the limit of 72 dB(A).

Appendix

Figure 1: Microphone positions for measurement of compressed air noise

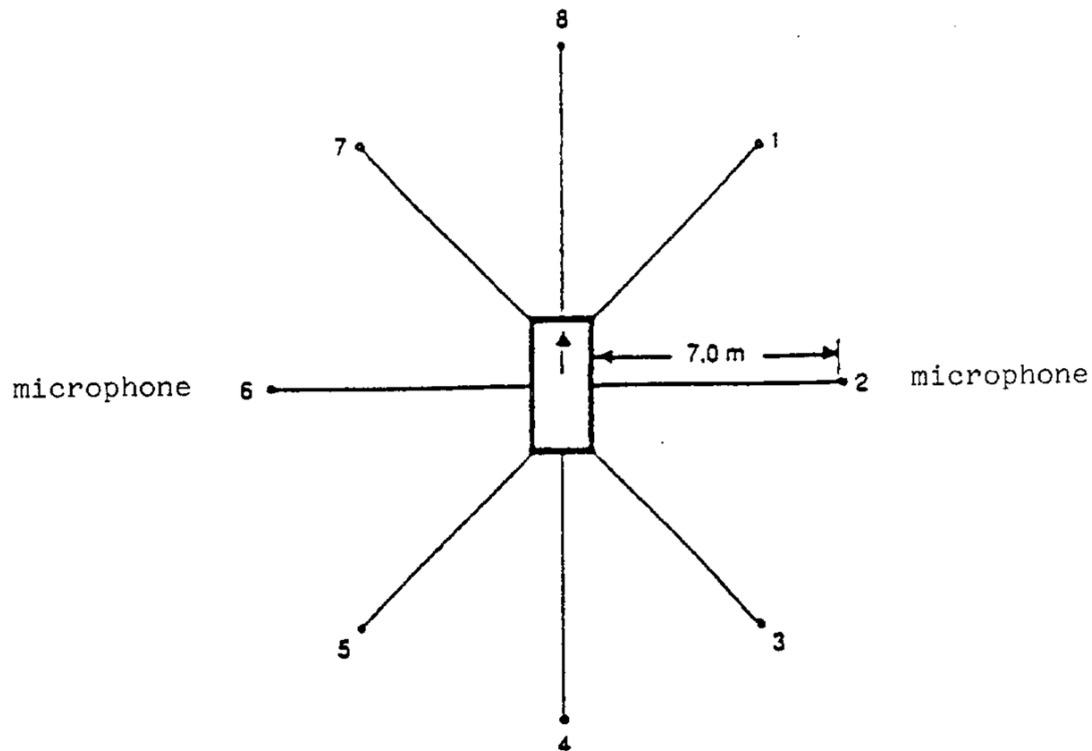

The measurement is performed at the stationary vehicle in accordance with Figure 1, using two microphone positions at a distance of 7 m from the contour of the vehicles and at 1,2 m above ground.

ANNEX VI

CHECKS ON CONFORMITY OF PRODUCTION FOR VEHICLES

1. GENERAL

The requirements of this Annex are consistent with the test to be held to check conformity of production (COP) in accordance with point 5 of Annex I.

2. TESTING PROCEDURE

The test site and measuring instruments shall be those described in Annex II.

2.1. The vehicle(s) under test shall be subjected to the test for measurement of sound of vehicle in motion set out in point 4.1 of Annex II.

2.2. Compressed air noise

Vehicles having a technically permissible maximum laden mass exceeding 2800 kg and equipped with compressed air systems shall be subjected to the additional test for measurement of the compressed air noise set out in point 1 of Annex V.

2.3. Additional sound emission provisions

The vehicle manufacturer shall assess the compliance with ASEP by an appropriate evaluation or may perform the test described in Annex VII.

3. SAMPLING AND EVALUATION OF THE RESULTS

One vehicle has to be chosen and subjected to the tests set out in point 2 of this Annex. If the sound level of the vehicle tested does not exceed by more than 1 dB(A) the limit value set out in Annex III, and, where appropriate, point 3 of Annex V, the vehicle type shall be considered to conform to the requirements of this Regulation.

If one of the test results does not comply with the COP requirements of Annex X to Directive 2007/46/EC, two more vehicles of the same type shall be tested pursuant to point 2 of this Annex.

If the test results for the second and the third vehicle comply with the COP requirements of Annex X to Directive 2007/46/EC, the vehicle is considered in compliance with the COP.

If one of the test results of the second or third vehicle does not comply with the COP requirements of Annex X to Directive 2007/46/EC, the vehicle type shall be considered not to conform to the requirements of this Regulation and the manufacturer shall take the necessary measures to re-establish the conformity.

ANNEX VII

MEASURING METHOD TO EVALUATE COMPLIANCE WITH THE ADDITIONAL SOUND EMISSION PROVISIONS

1. GENERAL

This Annex describes a measuring method to evaluate compliance of the vehicle with the additional sound emission provisions (ASEP) set out in Article 7.

It is not mandatory to perform actual tests when applying for EU type-approval. The manufacturer shall sign the declaration of compliance set out in the Appendix. The approval authority may ask for additional information about the declaration of compliance and carry out the tests described below.

The procedure set out in this Annex requires the performance of a test in accordance with Annex II. The test specified in Annex II shall be carried out on the same test track under conditions similar to those required in the tests prescribed in this Annex.

2. MEASURING METHOD

2.1 Measuring instruments and condition of measurements

Unless otherwise specified, the measuring instruments, the conditions of the measurements and the condition of the vehicle are equivalent to those specified in points 2 and 3 of Annex II.

If the vehicle has different modes that affect sound emission, all modes shall comply with the requirements of this Annex. In the case where the manufacturer has performed tests to prove to

the approval authority compliance with those requirements, the modes used during those tests shall be reported in a test report.

2.2. Method of testing

Unless otherwise specified, the conditions and procedures of points 4.1 to 4.1.2.1.2.2 of Annex II shall be used. For the purpose of this Annex, single test runs shall be measured and evaluated.

2.3. Control range

Operation conditions are as follows:

Vehicle speed V_{AA} $v_{AA} \geq 20$ km/h

ASEP:

Vehicle acceleration a_{wot} $a_{wot} \leq 5,0$ m/s²

ASEP

Engine speed n_{BB} $n_{BB} \leq 2,0 * PMR^{-0,222} * s$ or

ASEP

$n_{BB} \leq 0,9 * s$, whichever is the lowest

Vehicle speed V_{BB} ASEP:

if n_{BB} ASEP is reached in one gear $v_{BB} \leq 70$ km/h

in all other cases $v_{BB} \leq 80$ km/h

gears $K \leq$ gear ratio i as determined in Annex II

If the vehicle, in the lowest valid gear, does not achieve the maximum engine speed below 70 km/h, the vehicle speed limit is 80 km/h.

2.4. Gear ratios

The ASEP requirements apply to every gear ratio K that leads to test results within the control range as defined in point 2.3 of this Annex.

In case of vehicles with automatic transmissions, adaptive transmissions and CVTs tested with non-locked gear ratios, the test may include a gear ratio change to a lower range and a higher acceleration. A gear change to a higher range and a lower acceleration is not allowed. A gear shift which leads to a condition that is not in compliance with the boundary conditions shall be avoided. In such a case, it is permitted to establish and use electronic or mechanical devices, including alternate gear selector positions. In order for the ASEP test to be representative and repeatable (to the approval authority), the vehicles shall be tested using production gearbox calibration.

2.5. Target conditions

The sound emission shall be measured in each valid gear ratio at the four test points as specified below.

The first test point P_1 is defined by using an entry speed v_{AA} of 20 km/h. If a stable acceleration condition cannot be achieved, the speed shall be increased in steps of 5 km/h until a stable acceleration is reached.

The fourth test point P_4 is defined by the maximum vehicle speed at BB' in that gear ratio within the boundary conditions in accordance with point 2.3.

The other two test points are calculated using the following formula:

Test Point P_j: $v_{BB_j} = v_{BB_1} + ((j - 1)/3) * (v_{BB_4} - v_{BB_1})$ for $j = 2$ and 3

Where:

v_{BB_1} = vehicle speed at BB' of test point P₁
 v_{BB_4} = vehicle speed at BB' of test point P₄

Tolerance for v_{BB_j} : ± 3 km/h

For all test points the boundary conditions as specified in point 2.3 shall be met.

2.6. Test of the vehicle

The path of the centreline of the vehicle shall follow line CC' as closely as possible throughout the entire test, starting from the approach to line AA' until the rear of the vehicle passes line BB'.

At line AA' the accelerator shall be fully depressed. To achieve a more stable acceleration or to avoid a down shift between line AA' and BB' pre-acceleration before line AA' may be used. The accelerator shall be kept in depressed condition until the rear of the vehicle reaches line BB'.

For every separate test run, the following parameters shall be determined and noted:

The maximum A-weighted sound pressure level of both sides of the vehicle, indicated during each passage of the vehicle between the two lines AA' and BB', shall be mathematically rounded to the first decimal place ($L_{wot,kj}$). If a sound peak obviously out of character with the general sound pressure level is observed, the measurement shall be discarded. Left and right side may be measured simultaneously or separately.

The vehicle speed readings at AA' and BB' shall be reported with the first significant digit after the decimal place ($v_{AA,kj}$; $v_{BB,kj}$).

If applicable, the engine speed readings at AA' and BB' shall be reported as a full integer value ($n_{AA,kj}$; $n_{BB,kj}$).

The calculated acceleration shall be determined in accordance to the formula in point 4.1.2.1.2 of Annex II and reported to the second digit after the decimal place ($a_{wot,test,kj}$).

3. ANALYSIS OF RESULTS

3.1. Determination of the anchor point for each gear ratio

For measurements in gear i and lower, the anchor point consists of the maximum sound level L_{woti} , the reported engine speed n_{woti} and vehicle speed v_{woti} at BB' of gear ratio i of the acceleration test in Annex II.

$L_{anchor,i}$ = $L_{woti,Annex II}$
 $n_{anchor,i}$ = $n_{BB,woti,Annex II}$
 $v_{anchor,i}$ = $v_{BB,woti,Annex II}$

For measurements in gear $i+1$ the anchor point consists of the maximum sound level L_{woti+1} , the reported engine speed n_{woti+1} and vehicle speed v_{woti+1} at BB' of gear ratio $i+1$ of the acceleration test in Annex II.

$L_{anchor,i+1}$ = $L_{woti+1,Annex II}$
 $n_{anchor,i+1}$ = $n_{BB,woti+1,Annex II}$
 $v_{anchor,i+1}$ = $v_{BB,woti+1,Annex II}$

3.2. Slope of the regression line for each gear

The sound measurements shall be evaluated as a function of engine speed in accordance with point 3.2.1.

3.2.1. Calculation of the slope of the regression line for each gear

The linear regression line is calculated using the anchor point and the four correlated additional measurements.

$$\text{Slope}_k = \frac{\sum_{j=1}^5 (n_j - \bar{n})(L_j - \bar{L})}{\sum_{j=1}^5 (n_j - \bar{n})^2}$$

(in dB/1 000 min⁻¹)

With

$$\bar{L} = \frac{1}{5} \sum_{j=1}^5 L_j$$

and

$$\bar{n} = \bar{n}_1 \frac{1}{5} \sum_{j=1}^5 n_j$$

where n_j = engine speed measured at line BB'

3.2.2. Slope of the regression line for each gear

The Slope_k of a particular gear for the further calculation is the derived result of the calculation in point 3.2.1 rounded to the first decimal place, but not higher than 5 dB/1 000 min⁻¹.

3.3. Calculation of the linear sound level increase expected for each measurement

The sound level $L_{\text{ASEP},kj}$ for measurement point j and gear k shall be calculated using the engine speeds measured for each measurement point, using the slope specified in point 3.2 to the specific anchor point for each gear ratio.

For $n_{\text{BB}_k,j} \leq n_{\text{anchor},k}$:

$$L_{\text{ASEP}_k,j} = L_{\text{anchor}_k} + (\text{Slope}_k - Y) * (n_{\text{BB}_k,j} - n_{\text{anchor},k})/1\ 000$$

For $n_{\text{BB}_k,j} > n_{\text{anchor},k}$:

$$L_{\text{ASEP}_k,j} = L_{\text{anchor}_k} + (\text{Slope}_k + Y) * (n_{\text{BB}_k,j} - n_{\text{anchor},k})/1\ 000$$

Where $Y = 1$

3.4. Samples

On request of the approval authority two additional runs within the boundary conditions in accordance with point 2.3 shall be carried out.

4. INTERPRETATION OF RESULTS

Every individual noise measurement shall be evaluated.

The sound level of every specified measurement point shall not exceed the limits given below:

$$L_{kj} \leq L_{\text{ASEP}_k,j} + X$$

With:

- x = 3 dB(A) for vehicle with a non-lockable automatic transmission or non-lockable CVT
- x = 2 dB(A) + limit value – L_{urban} of Annex II for all other vehicles

If the measured sound level at a point exceeds the limit, two additional measurements at the same point shall be carried out to verify the measurement uncertainty. The vehicle is still in compliance with ASEP, if the average of the three valid measurements at this specific point fulfils the specification.

5. REFERENCE SOUND ASSESSMENT

The reference sound is assessed at a single point in one discrete gear, simulating an acceleration condition starting with an entry speed at v_{aa} equal to 50 km/h and assuming an exit speed at v_{bb} equal to 61 km/h. The sound compliance at this point can either be calculated using the results of point 3.2.2 and the specification below or be evaluated by direct measurement using the gear as specified below.

5.1 The determination of gear K is as follows:

- K = 3 for all manual transmission and for automatic transmission with up to 5 gears;
- K = 4 for automatic transmission with 6 or more gears

If no discrete gears are available, e.g. for non-lockable automatic transmissions or non-lockable CVTs, the gear ratio for further calculation shall be determined from the acceleration test result in Annex II using the reported engine speed and vehicle speed at line BB'.

5.2. Determination of reference engine speed n_{ref_K}

The reference engine speed, n_{ref_K} , shall be calculated using the gear ratio of gear K at the reference speed of $v_{\text{ref}} = 61$ km/h.

5.3. Calculation of L_{ref}

$$L_{\text{ref}} = L_{\text{anchor}_K} + \text{Slope}_K * (n_{\text{ref}_K} - n_{\text{anchor}_K}) / 1000$$

L_{ref} shall be less than or equal to 76 dB(A).

For vehicles fitted with a manual gear box having more than four forward gears and equipped with an engine developing a rated maximum net power greater than 140 kW and having a rated maximum net power/maximum-mass ratio greater than 75 kW/t, L_{ref} shall be less than or equal to 79 dB(A).

For vehicles fitted with an automatic gear box having more than four forward gears and equipped with an engine developing a rated maximum net power greater than 140 kW and having a rated maximum net power/maximum-mass ratio greater than 75 kW/t, L_{ref} shall be less than or equal to 78 dB(A).

6. EVALUATION OF ASEP USING THE PRINCIPLE OF L_{urban}

6.1 General

This evaluation procedure is an alternative selected by the manufacturer to the procedure described in point 3 of this Annex and is applicable to all vehicle technologies. The manufacturer shall be responsible for determining the correct manner of testing. Unless otherwise specified, all testing and calculation shall be as specified in Annex II.

6.2. Calculation of $L_{\text{urban ASEP}}$

From any $L_{\text{wot ASEP}}$ as measured in accordance with this Annex, $L_{\text{urban ASEP}}$ shall be calculated as follows:

- (a) calculate $a_{\text{wot test ASEP}}$ as specified in point 4.1.2.1.2.1 or point 4.1.2.1.2.2 of Annex II, as applicable;
- (b) determine the vehicle speed ($V_{\text{BB ASEP}}$) at BB' during the $L_{\text{wot ASEP}}$ test;
- (c) calculate $k_{\text{P ASEP}}$ as follows:

$$k_{\text{P ASEP}} = 1 - (a_{\text{urban}}/a_{\text{wot test ASEP}})$$

Test results where $a_{\text{wot test ASEP}}$ are less than a_{urban} shall be disregarded.

- (d) calculate $L_{\text{urban measured ASEP}}$ as follows:

$$L_{\text{urban measured ASEP}} =$$

$$L_{\text{wot ASEP}} - k_{\text{P ASEP}} * (L_{\text{wot ASEP}} - L_{\text{crs}})$$

For further calculation, use the L_{urban} from Annex II without rounding, including the digit after the decimal (xx.x).

- (e) calculate $L_{\text{urban normalized}}$ as follows:

$$L_{\text{urban normalized}} = L_{\text{urban measured ASEP}} - L_{\text{urban}}$$

- (f) calculate $L_{\text{urban ASEP}}$ as follows:

$$L_{\text{urban ASEP}} =$$

$$L_{\text{urban normalized}} - (0,15 * (V_{\text{BB ASEP}} - 50))$$

- (g) compliance with sound level limits:

$L_{\text{urban ASEP}}$ shall be less than or equal to 3,0 dB.

Appendix

Model statement of compliance with the Additional Sound Emission Provisions

(Maximum format: A4 (210 × 297 mm))

(Name of manufacturer) attests that vehicles of this type (type with regard to its sound emission pursuant to Regulation (EU) No 540/2014) comply with the requirements of Article 7 of Regulation (EU) No 540/2014.

(Name of manufacturer) makes this statement in good faith, after having performed an appropriate evaluation of the sound emission performance of the vehicles.

Date:

Name of authorized representative:

Signature of authorized representative:

ANNEX VIII

MEASURES CONCERNING THE ACOUSTIC VEHICLE ALERTING SYSTEM (AVAS)

This Annex sets out measures concerning the Acoustic Vehicle Alerting System (AVAS) for hybrid electric and pure electric vehicles.

AVAS

1. System performance

If AVAS is installed on a vehicle, it shall comply with the requirements referred to below.

2. Operation conditions

(a) Sound generation method

The AVAS shall automatically generate a sound in the minimum range of vehicle speed from start up to approximately 20 km/h and during reversing. Where the vehicle is equipped with an internal combustion engine that is in operation within the vehicle speed range defined above, the AVAS shall not generate a sound.

For vehicles having a reversing sound warning device, it is not necessary for the AVAS to generate a sound whilst reversing.

(b) Switch

The AVAS shall be fitted with a switch which is easily accessible by the vehicle driver in order to allow engaging and disengaging. Upon restarting the vehicle, AVAS shall default to the switched on position.

(c) Attenuation

The AVAS sound level may be attenuated during periods of vehicle operation.

3. Sound type and volume

- (a) The sound to be generated by the AVAS shall be a continuous sound that provides information to the pedestrians and other road users of a vehicle in operation. The sound should be easily indicative of vehicle behaviour and should sound similar to the sound of a vehicle of the same category equipped with an internal combustion engine.
- (b) The sound to be generated by the AVAS shall be easily indicative of vehicle behaviour, for example, through the automatic variation of sound level or characteristics in synchronization with vehicle speed.
- (c) The sound level generated by the AVAS shall not exceed the approximate sound level of a vehicle of the M₁ category equipped with an internal combustion engine and operating under the same conditions.

ANNEX IX

EU TYPE-APPROVAL IN RESPECT OF THE SOUND LEVEL OF SILENCING SYSTEMS AS SEPARATE TECHNICAL UNITS (REPLACEMENT SILENCING SYSTEMS)

1. APPLICATION FOR EU TYPE-APPROVAL

- 1.1. The application of EU type-approval pursuant to Article 7(1) and (2) of Directive 2007/46/EC in respect of a replacement silencing system, or components thereof, as a separate technical unit intended for vehicles of categories M₁ and N₁ shall be submitted by the vehicle manufacturer or the manufacturer of the separate technical unit in question.
- 1.2. A model for the information document is contained in Appendix 1.
- 1.3. At the request of the technical service concerned, the applicant shall submit:
 - 1.3.1 two examples of the system in respect of which application for EU type-approval has been made,
 - 1.3.2 a silencing system of the type originally fitted to the vehicle when EU type-approval was granted,
 - 1.3.3 a vehicle representative of the type to which the system is to be fitted, which meets the requirements of point 2.1 of Annex VI,
 - 1.3.4 a separate engine corresponding to the type of vehicle described.

2. MARKINGS

- 2.4.1. The replacement silencing system, or components thereof, excluding fixing hardware and pipes shall bear:
 - 2.4.1.1. the trade mark or trade name of the manufacturer of the replacement silencing system and its components,
 - 2.4.1.2. the manufacturer's trade description.
- 2.4.2. These marks shall be clearly legible and indelible, even when the system is fitted to the vehicle.

3. GRANTING OF EU TYPE-APPROVAL

- 3.1. If the relevant requirements are satisfied, EU type-approval pursuant to Article 9(3) and, if applicable, Article 10(4) of Directive 2007/46/EC shall be granted.
- 3.2. A model for the EU type-approval certificate is contained in Appendix 2.
- 3.3. A type-approval number in accordance with Annex VII to Directive 2007/46/EC shall be assigned to each type of replacement silencing system, or components thereof, approved as a separate technical unit; section 3 of the type-approval number shall indicate the number of this Regulation. Furthermore, if the replacement silencing system is intended to be fitted on vehicle types complying with the limit values of Phase 1 in Annex III only, section 3 of the type-approval number shall be followed by the character 'A'. If the replacement silencing system is intended to be fitted on vehicle types complying with the limit values of Phase 2 in Annex III only, section 3 of the type-approval number shall be followed by the character 'B'. If the replacement silencing system is intended to be fitted on vehicle types complying with the limit values of Phase 3 in Annex III, section 3 of the type-approval number shall be followed by the character 'C'. The same Member State shall not assign the same number to another type of replacement silencing system, or components thereof.

4. EU TYPE-APPROVAL MARK

- 4.1. Every replacement silencing system, or components thereof, excluding fixing hardware and pipes, conforming to a type approved under this Regulation shall bear an EU type-approval mark.
- 4.2. The EU type-approval mark shall consist of a rectangle surrounding the lower case letter 'e' followed by the distinguishing letter(s) or number of the Member State which has granted the approval:
 - '1' for Germany
 - '2' for France
 - '3' for Italy
 - '4' for the Netherlands
 - '5' for Sweden
 - '6' for Belgium
 - '7' for Hungary
 - '8' for the Czech Republic
 - '9' for Spain
 - '11' for the United Kingdom
 - '12' for Austria
 - '13' for Luxembourg
 - '17' for Finland
 - '18' for Denmark
 - '19' for Romania
 - '20' for Poland
 - '21' for Portugal
 - '23' for Greece
 - '24' for Ireland
 - '25' for Croatia
 - '26' for Slovenia

- '27' for Slovakia
- '29' for Estonia
- '32' for Latvia
- '34' for Bulgaria
- '36' for Lithuania
- '49' for Cyprus
- '50' for Malta

It shall also include in the vicinity of the rectangle the 'base approval number' contained in section 4 of the type-approval number referred to in Annex VII to Directive 2007/46/EC, preceded by the two figures indicating the sequence number assigned to the most recent major technical amendment to this Regulation which was applicable at the time of the vehicle type-approval. For this Regulation in its original form, the sequence number is 00. Furthermore, that sequence number shall be preceded by the character 'A' if the replacement silencing system is intended to be fitted on vehicle types complying with the limit values of Phase 1 in Annex III only, or the character 'B' if the replacement silencing system is intended to be fitted on vehicle types complying with the limit values of Phase 2 in Annex III only, or the character 'C' if the replacement silencing system is intended to be fitted on vehicle types complying with the limit values of Phase 3 in Annex III.

- 4.3. The mark shall be clearly legible and indelible even when the replacement silencing system, or components thereof, is fitted to the vehicle.
- 4.4. A model for the EU type-approval mark is contained in Appendix 3.
5. SPECIFICATIONS
 - 5.1. General specifications
 - 5.1.1. The replacement silencing system, or components thereof, shall be designed, constructed and capable of being mounted so as to ensure that the vehicle complies with this Regulation under normal conditions of use, notwithstanding any vibrations to which it may be subject.
 - 5.1.2. The silencing system, or components thereof, shall be designed, constructed and capable of being mounted so that reasonable resistance to the corrosion phenomenon to which it is exposed is obtained having regard to the conditions of use of the vehicle.
 - 5.1.3. Additional prescriptions related to tamperability and manually adjustable multi-mode exhaust or silencing systems
 - 5.1.3.1. All exhaust or silencing systems shall be constructed in a way that does not easily permit removal of baffles, exit-cones and other parts whose primary function is as part of the silencing/expansion chambers. Where incorporation of such a part is unavoidable, its method of attachment shall be such that removal is not facilitated easily (e.g. with conventional threaded fixings) and shall also be attached such that removal causes permanent/irrecoverable damage to the assembly.
 - 5.1.3.2. Exhaust or silencing systems with multiple, manually adjustable operating modes shall meet all requirements in all operating modes. The reported sound levels shall be those resulting from the mode with the highest sound levels.
 - 5.2. Specifications regarding sound levels
 - 5.2.1. Conditions of measurement

5.2.1.1. The noise test of the silencing system and the replacement silencing system has to be executed with the same normal tyres, as defined in paragraph 2 of UNECE Regulation No 117. At the request of the manufacturer, the tests shall not be done with traction tyres, special use tyres or snow tyres, as defined in paragraph 2 of UNECE Regulation No 117. Such tyres could increase the sound level of the vehicle or would have a masking effect on the noise reduction performance comparison. The tyres may be of used condition but shall satisfy legal requirements for in-traffic use.

5.2.2. The noise reduction performance of the replacement silencing system, or components thereof, shall be verified by means of the methods described in point 1 of Annex II. In particular, for the application of this point, reference shall be made to the amendment level of this Regulation which was in force at the time of type-approval of the new vehicle.

(a) Measurement with running vehicle

When the replacement silencing system, or components thereof, is mounted on the vehicle described in point 1.3.3, the sound levels obtained shall satisfy one of the following conditions:

- (i) the value measured (rounded to the nearest integer) shall not exceed by more than 1 dB(A) the type-approval value obtained under this Regulation with the type of vehicle concerned;
- (ii) the value measured (before any rounding to the nearest integer) shall not exceed by more than 1 dB(A) the noise value measured (before any rounding to the nearest integer) on the vehicle described in point 1.3.3., when this is fitted with a silencing system corresponding to the type fitted to the vehicle when submitted for type-approval under this Regulation.

Where back-to-back comparison of the replacement silencing system with the original system is chosen, for the application of point 4.1.2.1.4.2 and/or point 4.1.2.2.1.2 of Annex II, it is allowed to have a gear change to higher accelerations and the use of electronic or mechanical devices to prevent this downshift is not mandatory. If under these conditions the sound level of the test vehicle becomes higher than the COP values, the technical service will decide on the representativeness of the test vehicle.

(b) Measurement with stationary vehicle

When the replacement silencing system, or components thereof, is mounted on the vehicle described in point 1.3.3, the sound levels obtained shall satisfy one of the following conditions:

- (i) the value measured (rounded to the nearest integer) shall not exceed by more than 2 dB(A) the type-approval value obtained under this Regulation with the type of vehicle concerned;
- (ii) the value measured (before any rounding to the nearest integer) shall not exceed by more than 2 dB(A) the noise value measured (before any rounding to the nearest integer) on the vehicle described in point 1.3.3, when this is fitted with a silencing system corresponding to the type fitted to the vehicle when submitted for type-approval under this Regulation.

5.2.3. Further to the requirements of Annex II, any replacement silencing system, or components thereof, has to fulfil the applicable specifications of Annex VII. For

replacement silencing systems intended for vehicles type approved in accordance with Directive 70/157/EEC the requirements of Annex VII as well as the specifications of points 5.2.3.1 to 5.2.3.3 of this Annex do not apply.

- 5.2.3.1. Where the replacement silencing system, or components thereof, is a system or components with variable geometry, in the application for type-approval the manufacturer shall provide a statement in conformity with the Appendix to Annex VII that the silencing system type to be approved complies with the requirements of point 5.2.3 of this Annex. The approval authority may require any relevant test to verify the compliance of the silencing system type to the additional sound emission provisions.
- 5.2.3.2. Where the replacement silencing system, or components thereof, is not a system with variable geometry, it is sufficient in the application for type-approval that the manufacturer provides a statement in conformity with the Appendix to Annex VII that the silencing system type to be approved complies with the requirements of point 5.2.3 of this Annex.
- 5.2.3.3. The compliance statement shall read as follows: ‘(Name of the manufacturer) attests that the silencing system of this type complies with the requirements of point 5.2.3 of Annex IX to Regulation (EU) No 540/2014. (Name of the manufacturer) makes this statement in good faith, after having performed an appropriate engineering evaluation of the sound emission performance over the applicable range of operating conditions.’
- 5.3. Measurement of the vehicle performances
 - 5.3.1. The replacement silencing system, or components thereof, shall be such as to ensure that vehicle performance is comparable with that achieved with the original equipment silencing system or components thereof.
 - 5.3.2. The replacement silencing system or, depending on the manufacturer's choice, the components of that system shall be compared with an original silencing system, or components thereof, which are also in new condition, successively mounted on the vehicle mentioned in point 1.3.3.
 - 5.3.3. The verification shall be carried out by measuring the back pressure pursuant to point 5.3.4.

The value measured with the replacement silencing system shall not exceed the value measured with the original silencing system by more than 25 % under the conditions mentioned below.

5.3.4. Test method

5.3.4.1. Test method with engine

The measurements shall be conducted on the engine referred to in point 1.3.4 coupled to a dynamometer. With the throttle completely open, the bench shall be adjusted so as to obtain the engine speed (S) corresponding to the rated maximum power of the engine.

For the measurement of back pressure, the distance at which the pressure tap shall be placed from the exhaust manifold is indicated in Appendix 5.

5.3.4.2. Test method with vehicle

The measurements shall be carried out on the vehicle referred to point 1.3.3. The test shall be conducted either on the road or on a roller dynamometer.

With the throttle completely open, the engine shall be loaded so as to obtain the engine speed corresponding to the rated maximum power of the engine (engine speed S).

For the measurement of back pressure, the distance at which the pressure tap shall be placed from the exhaust manifold is indicated in Appendix 5.

5.4. Additional specifications regarding replacement silencing systems, or components thereof, containing acoustically absorbing fibrous materials

5.4.1. General

Sound absorbing fibrous materials may only be used in silencing systems, or components thereof, where any of the following conditions are fulfilled:

- (a) the exhaust gas is not in contact with the fibrous materials;
- (b) the silencing system, or the components thereof, are of the same design family as systems, or components thereof, for which it has been proven, in the course of the type-approval process in accordance with the requirements of this Regulation, that they are not subject to deterioration.

Unless one of those conditions is fulfilled, the complete silencing system, or components thereof, shall be submitted to conventional conditioning using one of the three installations and procedures described below.

For the purposes of point (b) of the first subparagraph, a group of silencing system or silencing system components thereof shall be considered as being of the same design family when all of the following characteristics are the same:

- (a) the presence of net gas flow of the exhaust gases through the absorbing fibrous material when in contact with that material;
- (b) the type of the fibres;
- (c) where applicable, binder material specifications;
- (d) average fibre dimensions;
- (e) minimum bulk material packing density in kg/m^3 ;
- (f) maximum contact surface between the gas flow and the absorbing material;

5.4.1.1. Continuous road operation for 10 000 km

5.4.1.1.1. 50 ± 20 % of this operation shall consist of urban driving and the remaining operation shall be long-distance runs at high speed; continuous road operation may be replaced by a corresponding test-track programme.

The two speed regimes shall be alternated at least twice.

The complete test program shall include a minimum of 10 breaks of at least three-hour duration in order to reproduce the effects of cooling and any condensation which may occur.

5.4.1.2. Conditioning on a test bench

5.4.1.2.1. Using standard parts and observing the manufacturer's instructions, the silencing system, or components thereof, shall be fitted to the vehicle referred to in point 1.3.3 or the engine referred to in point 1.3.4. In the first case the vehicle shall be mounted on a roller dynamometer. In the second case, the engine shall be coupled to a dynamometer.

5.4.1.2.2. The test shall be conducted in six six-hour periods with a break of at least 12 hours between each period in order to reproduce the effects of cooling and any condensation which may occur.

5.4.1.2.3. During each six-hour period, the engine shall be run under the following conditions in turn:

- (a) five minutes at idling speed;
- (b) one-hour sequence under 1/4 load at 3/4 of rated maximum speed (S);
- (c) one-hour sequence under 1/2 load at 3/4 of rated maximum speed (S);
- (d) 10-minute sequence under full load at 3/4 of rated maximum speed (S);
- (e) 15-minute sequence under 1/2 load at rated maximum speed (S);
- (f) 30-minute sequence under 1/4 load at rated maximum speed (S).

Each period shall comprise two sequenced sets of those conditions in consecutive order from (a) to (f).

5.4.1.2.4. During the test, the silencing system, or components thereof, shall not be cooled by a forced draught simulation normal airflow around the vehicle.

Nevertheless, at the request of the manufacturer, the silencing system, or components thereof, may be cooled in order not to exceed the temperature recorded at its inlet when the vehicle is running at maximum speed.

5.4.1.3. Conditioning by pulsation

5.4.1.3.1. The silencing system, or components thereof, shall be fitted to the vehicle referred to in point 1.3.3 or to the engine referred to in point 1.3.4. In the first case, the vehicle shall be mounted on a roller dynamometer, and, in the second case, the engine shall be mounted on a dynamometer.

5.4.1.3.2. The test apparatus, a detailed diagram of which is shown in Figure 1 of the Appendix to Annex IV shall be fitted at the outlet of the silencing system. Any other apparatus providing equivalent results is acceptable.

5.4.1.3.3. The test apparatus shall be adjusted in such a way that the exhaust gas flow is alternately interrupted and re-established by the quick action valve for 2 500 cycles.

5.4.1.3.4. The valve shall open when the exhaust gas back pressure, measured at least 100 mm downstream of the intake flange, reaches a value of between 35 and 40 kPa. It shall close when this pressure does not differ by more than 10 % from its stabilized value with the valve opened.

5.4.1.3.5. The time-delay switch shall be set for the duration of gas exhaust resulting from the provisions laid down in point 5.4.1.3.4.

5.4.1.3.6. Engine speed shall be 75 % of the speed (S) at which the engine develops maximum power.

5.4.1.3.7. The power indicated by the dynamometer shall be 50 % of the full-throttle power measured at 75 % of engine speed (S).

5.4.1.3.8. Any drain holes shall be closed off during the test.

5.4.1.3.9. The entire test shall be completed within 48 hours. If necessary, one cooling period will be observed after each hour.

5.4.1.3.10 After conditioning, the sound level is checked pursuant to point 5.2.

6. EXTENSION OF EU TYPE-APPROVAL

The silencing system manufacturer or his representative may ask the administrative department which has granted the EU type-approval of the silencing system for one or several types of vehicles, for an extension of the approval to other types of vehicles.

The procedure is that set out in point 1. Notice of the extension of the EU type-approval (or refusal of extension) shall be communicated to the Member States in accordance with the procedure specified in Directive 2007/46/EC.

7. MODIFICATION OF THE TYPE OF SILENCING SYSTEM

In the case of modifications of the type approved pursuant to this Regulation, Articles 13 to 16 and Article 17(4) of Directive 2007/46/EC shall apply.

8. COP

8.1. Measures to ensure the conformity of production shall be taken in accordance with the requirements laid down in Article 12 of Directive 2007/46/EC.

8.2. Special provisions:

8.2.1. The tests referred to point 2.3.5 of Annex X to Directive 2007/46/EC are those prescribed in Annex XI to this Regulation.

8.2.2. The frequency of inspections referred to in point 3 of Annex X to Directive 2007/46/EC is normally once every two years.

9. INFORMATION INTENDED FOR USERS AND TECHNICAL INSPECTION

9.1. Each replacement silencing system shall be accompanied by a paper document issued by the manufacturer of the replacement silencing system or his representative. That paper document shall at least bear the following information:

- (a) EU type-approval number of the replacement silencing system (the 5th section indicating the number of the extension of the type-approval can be omitted);
- (b) EU type-approval mark;
- (c) make (trade name of manufacturer);
- (d) type and commercial description and/or part number;
- (e) company name and address of manufacturer;
- (f) name and address of the manufacturer's representative (if any);
- (g) data of the vehicles for which the replacement silencing system is intended:
 - (i) make,
 - (ii) type,
 - (iii) type-approval number,

Status: This is the original version (as it was originally adopted).

- (iv) engine code,
 - (v) maximum engine power
 - (vi) kind of transmission
 - (vii) any restriction concerning the vehicles where the system can be mounted
 - (viii) sound level for the vehicle in motion in dB(A) and stationary sound level in dB(A) at min^{-1} (if deviating to the values of the vehicle type-approval);
- (h) mounting instructions.
- 9.2. If the paper document referred to in point 9.1 consists of more than of sheet of paper all sheets shall bear at least a reference to the EU type-approval number.
- 9.3. The information concerning point 9.1(g) and (h) may be provided on the website of the manufacturer if the website address is indicated on the paper document.

Appendix 1

Information document No ... relating to EU type-approval as separate technical unit of replacement silencing systems for motor vehicles (Regulation (EU) No 540/2014)

The following information, if applicable, shall be supplied in triplicate and include a list of contents. Any drawings shall be supplied in appropriate scale and in sufficient detail on size A4 or on a folder of A4 format. Photographs, if any, shall show sufficient detail.

If the systems, components or separate technical units have electronic controls, information concerning their performance shall be supplied.

0. General
 - 0.1. Make (trade name of manufacturer):
 - 0.2. Type and general commercial description(s):
 - 0.3. Means of identification of type, if marked on the separate technical unit⁽¹⁹⁾:
 - 0.3.1. Location of that marking:
 - 0.5. Company name and address of manufacturer:
 - 0.7. In the case of components and separate technical units, location and method of affixing of the EU type-approval mark:
 - 0.8. Address(es) of assembly plant(s):
 - 0.9. Name and address of the manufacturer's representative (if any):
1. Description of the vehicle for which the device is intended (if the device is intended to be fitted to more than one vehicle type, the information requested under this point shall be supplied for each type concerned)
 - 1.1. Make (trade name of manufacturer):
 - 1.2. Type and general commercial description(s):
 - 1.3. Means of identification of type, if marked on the vehicle:
 - 1.4. Category of vehicle:
 - 1.5. EU whole-vehicle type-approval number:
 - 1.6. Power plant:
 - 1.6.1. Manufacturer of the engine:
 - 1.6.2. Manufacturer's engine code:
 - 1.6.3. Maximum net power (g): ... kW at ... min⁻¹ or maximum continuous rated power (electric motor): ... kW
 - 1.6.4. Pressure charger(s): original part or make and marking⁽²⁰⁾:
 - 1.6.5. Air filter: original part or make and marking⁽²⁰⁾:
 - 1.6.6. Intake silencer(s): original part or make and marking⁽²⁰⁾:

- 1.6.7. Exhaust silencer(s): original part or make and marking⁽²⁰⁾:
- 1.6.8. Catalyst: original part or make and marking⁽²⁰⁾:
- 1.6.9. Particulate Trap(s): original part or make and marking⁽²⁰⁾:
- 1.7. Transmission
 - 1.7.1. Type (mechanical, hydraulic, electric, etc.):
- 1.8. Non-engine devices designed to reduce noise: original part or description⁽²⁰⁾:
- 1.9. Sound-level values:
 - moving vehicle: ... dB(A), speed stabilised before acceleration at ... km/h;
 - stationary vehicle dB(A), at ... min⁻¹
- 1.10. Value of the back pressure: ... Pa
- 1.11. Any restrictions in respect of use and mounting requirements:
- 2. Remarks:
- 3. Description of the device
 - 3.1. A description of the replacement silencing system indicating the relative position of each system component, together with mounting instructions
 - 3.2. Detailed drawings of each component, so that they can be easily located and identified, and reference to the materials used. These drawings shall indicate the place provided for the compulsory affixing of the EU type-approval mark

Date:

Signed:

Position in company:

Appendix 2

MODEL EU type-approval certificate
(Maximum Format: A4 (210 × 297 mm))

Stamp of approval authority

Communication concerning the

- type-approval⁽²¹⁾
- extension of type-approval⁽²¹⁾
- refusal of type-approval⁽²¹⁾
- withdrawal of type-approval⁽²¹⁾

of a type of a separate technical unit of silencing systems with regard to Regulation (EU) No 540/2014

Type-approval number:

Reason for extension:

SECTION I.

1. Make (trade name of manufacturer):
- 0.2. Type and general commercial description(s):
- 0.3. Means of identification of type if marked on the separate technical unit⁽²²⁾:
 - 0.3.1. Location of that marking:
- 0.4. Category of vehicle⁽²³⁾:
- 0.5. Company name and address of manufacturer:
- 0.7. In the case of components and separate technical units, location and method of affixing of the EU type-approval mark:
- 0.8. Address(es) of assembly plant(s):
- 0.9. Name and address of the manufacturer's representative (if any):

SECTION II.

- II Additional information (where applicable): See Addendum
2. Technical service responsible for carrying out the tests:
3. Date of test report:
4. Number of test report:
5. Remarks (if any): See Addendum
6. Place:
7. Date:
8. Signature:

Status: This is the original version (as it was originally adopted).

9. The index to the information package lodged with the approval authority, which may be obtained on request, is attached.

Attachments:	Information package
	Test report

Addendum

to EU type-approval certificate No ...

1. Additional information
 - 1.1. Description of the vehicle for which the device is intended (if the device is intended to be fitted to more than one vehicle type, the information requested under this point shall be supplied for each type concerned)
 - 1.1.1. Make (trade name of manufacturer):
 - 1.1.2. Type and general commercial description(s):
 - 1.1.3. Means of identification of type, if marked on the vehicle:
 - 1.1.4. Category of vehicle:
 - 1.1.5. EU whole vehicle type-approval number:
 - 1.2. Power plant:
 - 1.2.1. Manufacturer of the engine:
 - 1.2.2. Manufacturer's engine code:
 - 1.2.3. Maximum net power (g): ... kW at ... min⁻¹ or maximum continuous rated power (electric motor) ... kW
2. Test results
 - 2.1. Sound level of moving vehicle: ... dB(A)
 - 2.2. Sound level of stationary vehicle: ... dB(A) at ... min⁻¹
 - 2.3. Value of the back pressure: ... Pa
3. Remarks:

Appendix 3

Model for the EU type-approval mark

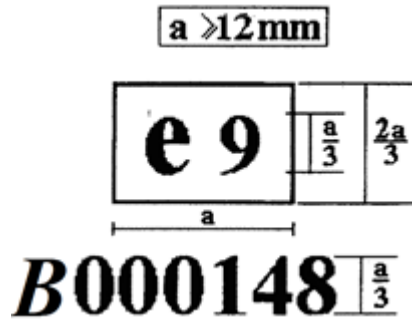

The silencing system, or components thereof, bearing the above EU type-approval mark is a device which has been approved in Spain (e 9) pursuant to Regulation (EU) No 540/2014 under the base approval number 0148, complying with the limit values of Phase 2 in Annex III to that Regulation.

The figures used are only indicative.

Appendix 4

Test apparatus

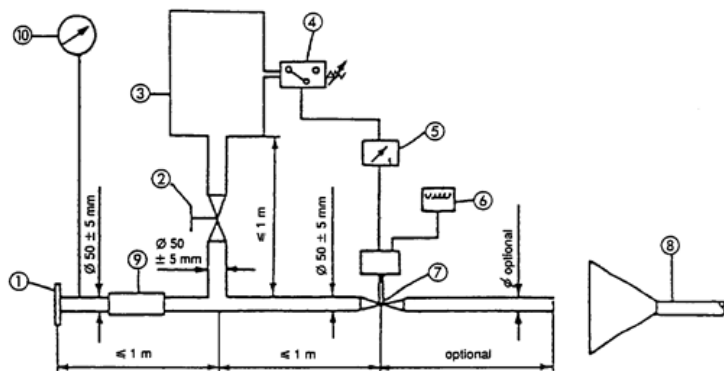

Appendix 5

Measuring points — back pressure

Examples of possible measuring points for loss-of-pressure tests. The exact measuring point shall be specified in the test report. It shall be in an area where gas flow is regular.

1. Figure 1
Single pipe



2. Figure 2
Partly twin pipe 1



3. Figure 3
Twin pipe

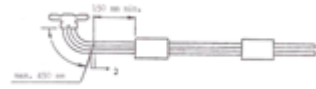

ANNEX X

CHECKS ON CONFORMITY OF PRODUCTION FOR REPLACEMENT SILENCING SYSTEM AS A SEPARATE TECHNICAL UNIT

1. GENERAL

These requirements are consistent with the test to be held to check COP in accordance with point 8 of Annex IX.

2. TESTING AND PROCEDURES

The methods of testing, measuring instruments and interpretation of results shall be those described in point 5 of Annex IX. The replacement silencing system, or components thereof, under test shall be subjected to the test as described in points 5.2, 5.3 and 5.4 of Annex IX.

3. SAMPLING AND EVALUATION OF THE RESULTS

3.1. One silencing system or components thereof shall be chosen and subjected to the tests of point 2. If the test results fulfil the COP requirements of point 8.1 of Annex IX, the type of silencing system or component shall be considered to be in compliance with COP.

3.2. If one of the test results does not comply with the COP requirements of point 8.1 of Annex IX, two more silencing systems, or components thereof, of the same type shall be tested pursuant to point 2 of this Annex.

Status: This is the original version (as it was originally adopted).

- 3.3. If the test results for the second and the third silencing system, or components thereof, comply with the conformity of production requirements of point 8.1 of Annex IX, the type of silencing system, or components thereof, shall be considered to be in compliance with the conformity of production.
- 3.4. If one of the test results for the second or third silencing system, or components thereof, does not comply with the COP requirements of point 8.1 of Annex IX, the type of silencing system, or components thereof, shall be considered not to comply with the requirements of this Regulation and the manufacturer shall take the necessary measures to re-establish the conformity.

ANNEX XI

AMENDMENTS TO DIRECTIVE 2007/46/EC

Directive 2007/46/EC is hereby amended as follows:

Part A

1. Annex IV shall be amended as follows:

(a) the following row shall be inserted in the table in Part I:

Item	Subject	Regulatory act	Applicability									
			M ₁	M ₂	M ₃	N ₁	N ₂	N ₃	O ₁	O ₂	O ₃	O ₄
'1A	Sound level	Regulation (EU) No 540/2014	X	X	X	X	X	X				

(b) the following row shall be inserted in Table 1 of Appendix 1 of Part I:

Item	Subject	Regulatory act	Specific issues	Applicability and specific requirements
'1A	Sound level	Regulation (EU) No 540/2014		A'

(c) the following row shall be inserted in Table 2 of Appendix 1 of Part I:

Item	Subject	Regulatory act	Specific issues	Applicability and specific requirements
'1A	Sound level	Regulation (EU) No 540/2014		A'

Status: This is the original version (as it was originally adopted).

2. In Annex VI, the following row shall be inserted in the table in the Appendix to Model A:

Item	Subject	Regulatory act reference	As amended by	Applicable to versions
'1A	Sound Level	Regulation (EU) No 540/2014'		

3. Annex XI shall be amended as follows:

- (a) in Appendix 1, the following row shall be inserted in the table:

Item	Subject	Regulatory act reference	M ₁ ≤ 2 500 (l) kg	M ₁ > 2 500 (l) kg	M ₂	M ₃
'1A	Sound level	Regulation (EU) No 540/2014	H	G+H	G+H	G+H'

- (b) in Appendix 2, the following row shall be inserted in the table:

Item	Subject	Regulatory act reference	M ₁	M ₂	M ₃	N ₁	N ₂	N ₃	O ₁	O ₂	O ₃	O ₄
'1A	Sound level	Regulation (EU) No 540/2014	X	X	X	X	X	X'				

- (c) in Appendix 3, the following row shall be inserted in the table:

Item	Subject	Regulatory act reference	M ₁
'1A	Sound level	Regulation (EU) No 540/2014	X'

- (d) in Appendix 4, the following row shall be inserted in the table:

Item	Subject	Regulatory act reference	M ₁	M ₂	M ₃	N ₁	N ₂	N ₃	O ₁	O ₂	O ₃	O ₄
'1A	Sound level	Regulation (EU) No 540/2014	H	H	H	H	H	H'				

- (e) in Appendix 5, the following row shall be inserted in the table:

Status: This is the original version (as it was originally adopted).

Item	Subject	Regulatory act reference	Mobile crane of category N 3
'1A	Sound level	Regulation (EU) No 540/2014	T'

Part B

1. Annex IV shall be amended as follows:
 - (a) Item 1 in the table in Part I shall be deleted;
 - (b) Item 1 in Table 1 of Appendix 1 to Part I shall be deleted;
 - (c) Item 1 in Table 2 of Appendix 1 to Part I shall be deleted;
 - (d) Item 1 of the table in Part II shall be deleted.
2. In Annex VI, in the table in the Appendix to Model A, Item 1 shall be deleted.
3. Annex XI shall be amended as follows:
 - (a) Item 1 in the table in Appendix 1 shall be deleted;
 - (b) Item 1 in the table in Appendix 2 shall be deleted;
 - (c) Item 1 in the table in Appendix 3 shall be deleted;
 - (d) Item 1 in the table in Appendix 4 shall be deleted;
 - (e) Item 1 in the table in Appendix 5 shall be deleted.

ANNEX XII

CORRELATION TABLE

Directive 70/157/EEC	This Regulation
Article 1	—
Article 2	Article 4(1) and (2)
Article 2a	Article 4(3) and (4)
Article 3	—
Article 4	—
Article 5	—
Annex I, point 1	Annex I, point 1
Annex I, point 3	Annex I, point 2
Annex I, point 4	Annex I, point 3
Annex I, point 5	Annex I, point 4

Status: This is the original version (as it was originally adopted).

Annex I, point 6	Annex I, point 5
Annex I, Appendix 1	Annex I, Appendix 1
Annex I, Appendix 2	Annex I, Appendix 2
Annex I, point 2	Annex III
Annex II, points 1, 2, 3 and 4	Annex IX, points 1, 2, 3 and 4
Annex II, points 5 and 6	Annex IX, points 7 and 8
Annex II, Appendix 1	Annex IX, Appendix 1
Annex II, Appendix 2	Annex IX, Appendix 2
Annex II, Appendix 3	Annex IX, Appendix 3
Annex III	—

- (1) [OJ C 191, 29.6.2012, p. 76.](#)
- (2) Position of the European Parliament of 6 February 2013 (not yet published in the Official Journal) and position of the Council at first reading of 20 February 2014 (not yet published in the Official Journal). Position of the European Parliament of 2 April 2014 (not yet published in the Official Journal).
- (3) Directive 2002/49/EC of the European Parliament and of the Council of 25 June 2002 relating to the assessment and management of environmental noise ([OJ L 189, 18.7.2002, p. 12](#)).
- (4) Council Directive 70/157/EEC of 6 February 1970 on the approximation of the laws of the Member States relating to the permissible sound level and the exhaust system of motor vehicles ([OJ L 42, 23.2.1970, p. 16](#)).
- (5) Directive 2007/46/EC of the European Parliament and of the Council of 5 September 2007 establishing a framework for the approval of motor vehicles and their trailers, and of systems, components and separate technical units intended for such vehicles (Framework Directive) ([OJ L 263, 9.10.2007, p. 1](#)).
- (6) Regulation No 51 of the Economic Commission for Europe of the United Nations (UN/ECE) — Uniform provisions concerning the approval of motor vehicles having at least four wheels with regard to their noise emissions ([OJ L 137, 30.5.2007, p. 68](#)).
- (7) Regulation No 59 of the Economic Commission for Europe of the United Nations (UN/ECE) — Uniform provisions concerning the approval of replacement silencing systems ([OJ L 326, 24.11.2006, p. 43](#)).
- (8) Council Decision 97/836/EC of 27 November 1997 with a view to accession by the European Community to the Agreement of the United Nations Economic Commission for Europe concerning the adoption of uniform technical prescriptions for wheeled vehicles, equipment and parts which can be fitted to and/or be used on wheeled vehicles and the conditions for reciprocal recognition of approvals granted on the basis of these prescriptions ('Revised 1958 Agreement') ([OJ L 346, 17.12.1997, p. 78](#)).
- (9) Regulation (EC) No 661/2009 of the European Parliament and of the Council of 13 July 2009 concerning type-approval requirements for the general safety of motor vehicles, their trailers and systems, components and separate technical units intended therefor ([OJ L 200, 31.7.2009, p. 1](#)).
- (10) Regulation (EC) No 765/2008 of the European Parliament and of the Council of 9 July 2008 setting out the requirements for accreditation and market surveillance relating to the marketing of products and repealing Regulation (EEC) No 339/93 ([OJ L 218, 13.8.2008, p. 30](#)).
- (11) Decision No 1600/2002/EC of the European Parliament and of the Council of 22 July 2002 laying down the Sixth Community Environment Action Programme ([OJ L 242, 10.9.2002, p. 1](#)).
- (12) [OJ C 168 E, 14.6.2013, p. 72.](#)
- (13) Regulation No 85 of the Economic Commission for Europe of the United Nations (UN/ECE) — Uniform provisions concerning the approval of internal combustion engines or electric drive trains intended for the propulsion of motor vehicles of categories M and N with regard to the measurement of net power and the maximum 30 minutes power of electric drive trains ([OJ L 326, 24.11.2006, p. 55](#)).
- (14) Delete where not applicable.
- (15) If the means of identification of type contains characters not relevant to describe the vehicle types covered by the type-approval certificate such characters shall be represented in the documentation by the symbol: '?' (e.g. ABC??123??).
- (16) As defined in Annex IIA to Directive 2007/46/EC.
- (17) Delete where not applicable.
- (18) Given that the tyre contribution for overall sound emission is significant, regard must be had for existing regulatory provisions concerning tyre/road sound emissions. Traction tyres, snow tyres and special-use tyres as defined in paragraph 2 of UNECE Regulation No 117 shall be excluded during type-approval and conformity of production measurements at the request of the manufacturer in accordance with UNECE Regulation No 117 ([OJ L 307, 23.11.2011, p. 3](#)).

Status: This is the original version (as it was originally adopted).

- (19) If the means of identification of type contains characters not relevant to describe the vehicle types covered by the type-approval certificate such characters shall be represented in the documentation by the symbol: '?' (e.g. ABC??123??).
- (20) Delete where not applicable.
- (21) Delete where not applicable.
- (22) If the means of identification of type contains characters not relevant to describe the vehicle types covered by the type-approval certificate such characters shall be represented in the documentation by the symbol: '?' (e.g. ABC??123??).
- (23) As defined in Annex IIA to Directive 2007/46/EC.