



▼B**COMMISSION REGULATION (EEC) No 2568/91****of 11 July 1991****on the characteristics of olive oil and olive-residue oil and on the relevant methods of analysis**

THE COMMISSION OF THE EUROPEAN COMMUNITIES,

Having regard to the Treaty establishing the European Economic Community,

Having regard to Council Regulation No 136/66/EEC of 22 September 1966 on the establishment of a common organization of the market in oils and fats<sup>(1)</sup>, as last amended by Regulation (EEC) No 3577/90<sup>(2)</sup>, and in particular Article 35a thereof,

Whereas the Annex to Regulation No 136/66/EEC contains the descriptions and definitions of olive oil and olive-residue oil marketed within each Member State, in intra-Community trade and in trade with third countries;

Whereas, for the purpose of differentiating between the various types of oil, the physical and chemical characteristics of each of them and the organoleptic characteristics of virgin oil should be defined, in order to guarantee the purity and quality of the products concerned, without prejudice to other existing provisions;

Whereas the presence of the characteristics of the different types of oil should be determined uniformly throughout the Community; whereas, to that end, Community methods of chemical analysis and organoleptic evaluation should be established; whereas the use should be permitted, for a transitional period, of other methods of analysis applied in the Member States provided that where there is a difference in the results, those obtained using the common method will be decisive;

Whereas the definition of the physical and chemical characteristics of olive oil and of the methods of analysis entails the amendment of the additional notes to Chapter 15 of the combined nomenclature;

Whereas the method of evaluating the organoleptic characteristics of virgin oil includes the setting up of panels of selected and trained tasters; whereas the period necessary for establishing such a structure should therefore be fixed; whereas in view of the difficulties that some Member States will encounter in setting up panels of tasters, the use of panels in other Member States should be authorized;

Whereas, in order to ensure that the system of levies applicable to imports of olive residues functions correctly, a single method for the determination of the oil content of these products should be laid down;

Whereas, in order not to harm trade, provision should be made for oil packaged prior to the entry into force of this Regulation to be disposed of during a limited period;

Whereas it is necessary to repeal Commission Regulation (EEC) No 1058/77<sup>(3)</sup>, as last amended by Regulation (EEC) No 1858/88<sup>(4)</sup>;

Whereas the Management Committee for Oils and Fats has not delivered an opinion within the time limit set by its chairman,

HAS ADOPTED THIS REGULATION:

*Article 1*

1. Oils, the characteristics of which comply with those set out in points 1, 2 and 3 of Annex I to this Regulation, shall be deemed to be

<sup>(1)</sup> OJ No 172, 30. 9. 1966, p. 3025/66.

<sup>(2)</sup> OJ No L 353, 17. 12. 1990, p. 23.

<sup>(3)</sup> OJ No L 128, 24. 5. 1977, p. 6.

<sup>(4)</sup> OJ No L 166, 1. 7. 1988, p. 10.

**▼B**

virgin olive oil within the meaning of point 1 (a), (b) and (c) of the Annex to Regulation No 136/66/EEC.

2. Oil, the characteristics of which comply with those set out in point 4 of Annex I to this Regulation, shall be deemed to be lampante virgin olive oil within the meaning of point 1 (d) of the Annex to Regulation No 136/66/EEC.

3. Oil, the characteristics of which comply with those set out in point 5 of Annex I to this Regulation, shall be deemed to be refined olive oil within the meaning of point 2 of the Annex to Regulation No 136/66/EEC.

4. Oil, the characteristics of which comply with those set out in point 6 of Annex I to this Regulation, shall be deemed to be pure olive oil within the meaning of point 3 of the Annex to Regulation No 136/66/EEC.

5. Oil, the characteristics of which comply with those set out in point 7 of Annex I to this Regulation, shall be deemed to be olive-residue oil within the meaning of point 4 of the Annex to Regulation No 136/66/EEC.

6. Oil, the characteristics of which comply with those set out in point 8 of Annex I to this Regulation, shall be deemed to be refined olive-residue oil within the meaning of point 5 of the Annex to Regulation No 136/66/EEC.

7. Oil, the characteristics of which comply with those set out in point 9 of Annex I to this Regulation, shall be deemed to be olive-residue oil within the meaning of point 6 of the Annex to Regulation No 136/66/EEC.

*Article 2*

1. The characteristics of the oils laid down in Annex I shall be determined in accordance with the methods of analysis set out below:

- for the determination of the free fatty acids, expressed as the percentage of oleic acid, the method set out in Annex II,
- for the determination of the peroxide index, the method set out in Annex III,
- for the determination of aliphatic alcohols, the method set out in Annex IV,
- for the determination of the sterol content, the method set out in Annex V,
- for the determination of erythrodiol and uvaol, the method set out in Annex VI,
- for the determination of the saturated fatty acids in position 2 of the triglyceride, the method set out in Annex VII,
- for the determination of the trilinolein content, the method set out in Annex VIII,
- for spectrophotometric analysis, the method set out in Annex IX,
- for the determination of the fatty acid composition, the method set out in Annex X A and X B,
- for the determination of the volatile halogenated solvents, the method set out in Annex XI,
- for the evaluation of the organoleptic characteristics of virgin olive oil, the method set out in Annex XII,
- for proof that refining has taken place, the method set out in Annex XIII.

2. Evaluation of the organoleptic characteristics shall be carried out by ► **M3** an analyst specializing in sensory analysis or assisted by specialists ◀, according to the procedure described in the tasting notes referred to in Annex XII. Where analysis shows different characteristics to those resulting from the description of the product, the sample must be examined by a panel of tasters in accordance with the provisions of Annex XII.

**▼B**

Any second analysis shall be carried out by the panel according to the said provisions.

In order to ascertain the organoleptic characteristics in connection with operations relating to the intervention system, the panel of tasters will carry out this evaluation in accordance with the provisions of Annex XII.

*Article 3*

Until ►**M6** 28 February 1993 ◀, the introduction of the analysis methods provided for in Article 2 shall not impede the use by the Member States of other tested and scientifically valid methods, provided that products recognized as complying with the rules in force governing Community methods shall be allowed to move freely. Before using other methods, the Member States concerned shall notify them to the Commission.

Where one of the other methods produces a result different from that produced by the common method, the result obtained by the latter method shall be determinant.

**▼M5***Article 3a*

Where a dispute arises over the organoleptic characteristics of an oil being traded, the parties concerned may refer the matter to an approved tasting panel of their choice.

*Article 3b*

Where it is found that the organoleptic characteristics of an oil do not correspond to its description, the Member State concerned shall, without prejudice to any other penalties, apply administrative financial penalties, to be determined in the light of the seriousness of the irregularity detected.

In assessing the irregularity, attention shall be paid in particular to natural changes in the characteristics of an oil kept under normal conditions.

At the beginning of each half-year, the Member States shall inform the Commission of the number and type of irregularities detected and the penalties applied during the previous half-year.

*Article 4*

1. For the purpose of assessing organoleptic characteristics, the Member States shall set up panels of tasters responsible for official checks on these characteristics. The panels shall comply with the following conditions:

- they shall consist of tasters selected and trained in accordance with the rules laid down for the method set out in Annex XII,
- they shall possess the facilities and equipment required to carry out organoleptic assessments in accordance with the rules laid down for that method,
- they shall use the vocabulary specific to the sensory analysis of olive oil, the profile sheet and the grading table laid down for that method,
- they shall undertake to carry out the organoleptic assessments required at Community or international level at the time of periodic tests and at sessions for harmonizing criteria,
- they shall undertake to provide the Commission annually with all information on changes in the membership of panels and the number of assessments carried out as approved panels.

Each Member State shall approve panels meeting the above criteria and set up on its territory. It shall designate one of those panels to conduct revisions of analyses.

**▼M5**

Panels set up by the Member States prior to 1 November 1992 in accordance with the rules laid down for the method set out in Annex XII shall be considered as approved within the meaning of this Article.

Each Member State shall notify the Commission and the other Member States of the list of approved panels.

2. Where Member States encounter difficulties in setting up tasting panels in their territory, they may call on a tasting panel approved in another Member State.

3. Each Member State draw up a list of tasting panels set up by professional or inter-branch organizations in accordance with the conditions laid down in paragraph 1 and shall ensure that those conditions are complied with.

**▼M6***Article 5*

Additional notes 2, 3 and 4 to Chapter 15 of the combined nomenclature set out in Annex I to Council Regulation (EEC) No 2658/87<sup>(1)</sup> are replaced by the text set out in Annex XIV to this Regulation.

**▼B***Article 6*

1. The oil content of oil cake and other residues resulting from the extraction of olive oil (CN codes 2306 90 11 and 2306 90 19) shall be determined using the method set out in Annex XV.

2. The oil content referred to in paragraph 1 shall be expressed as a percentage of the weight of oil to the weight of dry matter.

*Article 7*

The Community provisions concerning the presence of undesirable substances, other than those referred to in Annex XI, shall apply.

*Article 8*

1. Member States shall notify the Commission of the measures taken to implement this Regulation.

2. Member States shall send the Commission, at the beginning of each half-year, a statement of the analytical data relating to the tests carried out during the previous half-year.

The results shall be considered by the Management Committee for Oils and Fats in accordance with the procedure laid down in Article 39 of Regulation No 136/66/EEC.

*Article 9*

Regulation (EEC) No 1058/77 is hereby repealed.

*Article 10*

1. This Regulation shall enter into force on the third day following its publication in the *Official Journal of the European Communities*.

However, the method set out in Annex XII shall apply from ►**M1** 1 November 1992 ◀, *except in so far as operations relating to the intervention system are concerned*.

**▼M5**

That method shall not apply to virgin olive oil prepared for the market prior to 1 November 1992.

<sup>(1)</sup> OJ No L 256, 7. 9. 1987, p. 1.

**▼B**

2. This Regulation shall not apply to olive oil and olive-residue oil packaged before the entry into force of this Regulation and marketed up to 31 October 1992.

This Regulation shall be binding in its entirety and directly applicable in all Member States.

**▼B***ANNEXES***Summary**

- Annex I: Characteristics of olive oil ...
- Annex II: Determination of the free fatty acids ...
- Annex III: Determination of the peroxide value ...
- Annex IV: ►**M6** Determination of wax content by capillary column gas-liquid chromatography ◀ ...
- Annex V: Determination of the composition and content of sterols by capillary-column gas chromatography ...
- Annex VI: Determination of erythrodiol and uvaol ...
- Annex VII: Determination of the saturated fatty acids in position 2 of the triglyceride ...
- Annex VIII: Determination of composition of trilinolein ...
- Annex IX: Spectrophotometric investigation in the ultraviolet ...
- Annex XA: Analysis by gas chromatography of methyl esters of fatty acids ...
- Annex XB: Preparation of methyl esters of fatty acids ...
- Annex XI: Determination of the volatile halogenated solvents of olive oil ...
- Annex XII: Organoleptic assessment of virgin olive oil ...
- Annex XIII: ►**M6** Neutralization and decolorization of olive oil in the laboratory ◀ ...
- Annex XIV: Additional Notes 2, 3 and 4 to Chapter 15 of the combined nomenclature ...
- Annex XV: Oil content of olive residue ...
- Annex XVI: Determination of iodine value ...

## ANNEX I

## CHARACTERISTICS OF OLIVE OIL

Type	Acidity % meq	Peroxide value meq O <sub>2</sub> /kg	Haloge- mated solvents mg/kg (1)	Waxes mg/ kg	Saturated fatty acids in position 2 of trigly- ceride %	Erythriol + Uvaol %	Trilinolein %	Cholesterol %	Brassicas- terol %	Campes- terol %	Stigmas- terol %	Betasitos- terol % (2)	Delta-7- stigmas- terol %	Total sterols mg/ kg
1. Extra virgin olive oil	M 1,0	M 20	M 0,20	▲C2 M 350 ▼	M 1,3	M 4,5	M 0,5AX:M 0,5		M 0,2	M 4,0	< Camp.	m 93,0	M 0,5	m 1 000
2. Virgin olive oil	M 2,0	M 20	M 0,20	M 250	M 1,3	M 4,5	M 0,5	M 0,5	M 0,2	M 4,0	< Camp.	m 93,0	M 0,5	m 1 000
3. Ordinary virgin olive oil	M 3,3	M 20	M 0,20	M 250	M 1,3	M 4,5	M 0,5	M 0,5	M 0,2	M 4,0	< Camp.	m 93,0	M 0,5	m 1 000
4. Virgin lampante olive oil	> 3,3	> 20	> 0,20	M 250	M 1,3	M 4,5	M 0,5	M 0,5	M 0,2	M 4,0	—	m 93,0	M 0,5	m 1 000
5. Refined olive oil	M 0,5	M 10	M 0,20	M 350	M 1,5	M 4,5	M 0,5	M 0,5	M 0,2	M 4,0	< Camp.	m 93,0	M 0,5	m 1 000
6. Olive oil	M 1,5	M 15	M 0,20	M 350	M 1,5	M 4,5	M 0,5	M 0,5	M 0,2	M 4,0	< Camp.	m 93,0	M 0,5	m 1 000
7. Crude olive residue oil	m 2,0	—	—	—	M 1,8	m 12	M 0,5	M 0,5	M 0,2	M 4,0	—	m 93,0	M 0,5	m 2 500
8. Refined olive residue oil	M 0,5	M 10	M 0,20	—	M 2,0	m 12	M 0,5	M 0,5	M 0,2	M 4,0	< Camp.	m 93,0	M 0,5	m 1 800
9. Olive residue oil	M 1,5	M 15	M 0,20	> 350	M 2,0	> 4,5	M 0,5	M 0,5	M 0,2	M 4,0	< Camp.	m 93,0	M 0,5	m 1 800

M = maximum, m = minimum.

(1) Overall upper limit for compounds detected by electron capture detector. For components detected individually the upper limit is 0,10 mg/kg.

(2) Delta-5,23-stigmastadianol + clerosterol + sitosterol + sitosterol + sitosterol + delta-5-avamesterol + delta-5-24 stigmastadienol.

Notes: An oil is to be rejected if any one of its characteristics lies outside the limit laid down.



## ▼ M2

Type	Acid composition						Sum (of the transoleic and translinolenic isomers %)	Sum (of the transoleic isomers %)	Sum (of the translinolenic isomers %)	$k_{232}$	$k_{270}$	$k_{270}$ with aluminium oxide +	Delta K	Panel test
	Myristic %	Linolenic %	Arachidic %	Eicosanoic %	Behenic %	Lignoceric %								
1. Extra virgin olive oil	M 0,1	M 0,9	M 0,7	M 0,5	M 0,3	M 0,5	< 0,03	< 0,03	< 0,03	M 2,40	M 0,20	M 0,10	M 0,01	≥ 6,5
2. Virgin olive oil	M 0,1	M 0,9	M 0,7	M 0,5	M 0,3	M 0,5	< 0,03	< 0,03	< 0,03	M 2,50	M 0,25	M 0,10	M 0,01	≥ 5,5
3. Ordinary virgin olive oil	M 0,1	M 0,9	M 0,7	M 0,5	M 0,3	M 0,5	< 0,03	< 0,03	< 0,03	M 2,50	M 0,25	M 0,10	M 0,01	≥ 3,5
4. Virgin lampante olive oil	M 0,1	M 0,9	M 0,7	M 0,5	M 0,3	M 0,5	< 0,10	< 0,10	< 0,10	M 3,70	> 0,25	M 0,11	—	< 3,5
5. Refined olive oil	M 0,1	M 0,9	M 0,7	M 0,5	M 0,3	M 0,5	< 0,20	< 0,20	< 0,30	M 3,40	M 1,20	—	M 0,16	—
6. Olive oil	M 0,1	M 0,9	M 0,7	M 0,5	M 0,3	M 0,5	< 0,20	< 0,20	< 0,30	M 3,30	M 1,00	—	M 0,13	—
7. Crude oil residue oil	M 0,1	M 0,9	M 0,7	M 0,5	M 0,3	M 0,5	< 0,20	< 0,20	< 0,10	—	—	—	—	—
8. Refined olive residue oil	M 0,1	M 0,9	M 0,7	M 0,5	M 0,3	M 0,5	< 0,40	< 0,40	< 0,35	M 5,50	M 2,50	—	M 0,25	—
9. Olive residue oil	M 0,1	M 0,9	M 0,7	M 0,5	M 0,3	M 0,5	< 0,40	< 0,40	< 0,35	M 5,30	M 2,00	—	M 0,20	—

## ▼ M6

For the purpose of establishing purity, where  $K_{270}$  exceeds the limit for the category concerned, it shall be determined again after passage over alumina.

▼**B**

## ANNEX II

**DETERMINATION OF THE FREE FATTY ACIDS**

## 1. DETERMINATION OF ACIDITY

The determination of free fatty acids in olive oils. The content of free fatty acids is expressed as acidity calculated conventionally.

1.1. **Principle**

A sample is dissolved in a mixture of solvents and the free fatty acids present titrated using an ethanolic solution of potassium hydroxide.

1.2. **Reagents**

All the reagents should be of recognized analytical quality and the water used either distilled or of equivalent purity.

1.2.1. ►**C1** Diethyl ether ◀; 95 % ethanol (v/v), mixture of equal parts by volume.

*Note:* ►**C1** Diethyl ether ◀ is highly inflammable and may form explosive peroxides. Special care should be taken in its use.

Neutralize precisely at the moment of use with the potassium hydroxide solution (1.2.2), with the addition of 0,3 ml of the phenolphthalein solution (1.2.3) per 100 ml of mixture.

*Note:* If it is not possible to use ►**C1** diethyl ether ◀, a mixture of solvents containing ethanol and toluene may be used. If necessary, ethanol may be replaced by propanol-2.

## 1.2.2. Potassium hydroxide, titrated ethanolic solution, c(KOH) about 0,1 mol/l or, if necessary, c(KOH) about 0,5 mol/l.

The exact concentration of the ethanolic solution of potassium hydroxide must be known and checked immediately prior to use. Use a solution prepared at least five days before use and decanted into a brown glass bottle with a rubber stopper. The solution should be colourless or straw coloured.

*Note:* A stable colourless solution of potassium hydroxide may be prepared as follows. Bring to the boil 1 000 ml of ethanol with 8 g of potassium hydroxide and 0,5 g of aluminium shavings and continue boiling under reflux for one hour. Distill immediately. Dissolve in the distillate the required quantity of potassium hydroxide. Leave for several days and decant the clear supernatant liquid from the precipitate of potassium carbonate.

The solution may also be prepared without distillation as follows: to 1 000 ml of ethanol add 4 ml of aluminium butylate and leave the mixture for several days. Decant the supernatant liquid and dissolve the required quantity of potassium hydroxide. The solution is ready for use.

## 1.2.3. Phenolphthalein, 10 g/l solution in 95 to 96 % ethanol (v/v) or alkaline blue, (in the case of strongly coloured fats) 20 g/l solution in 95 to 96 % ethanol (v/v).

1.3. **Apparatus**

Usual laboratory equipment including:

## 1.3.1. analytical balance;

## 1.3.2. 250 ml conical flask;

## 1.3.3. 10 ml burette, graduated in 0,05 ml.

1.4. **Procedure**

## 1.4.1. Preparation of the specimen for testing

(Carry out the test on the filtered sample. Where moisture and impurities together are less than 1 %, use the specimen without further treatment; where they exceed 1 %, it should be filtered.)

## 1.4.2. Taking the sample

**▼B**

Take a sample depending on the presumed acid number in accordance with the following table:

Expected acid value	Mass of sample (g)	Weighing accuracy (g)
< 1	20	0,05
1 to 4	10	0,02
4 to 15	2,5	0,01
15 to 75	0,5	0,001
> 75	0,1	0,0002

Weigh the sample in the conical flask (1.3.2).

## 1.4.3. Determination

Dissolve the sample (1.4.2) in 50 to 150 ml of the previously neutralized mixture of diethyl ►**C1** ether ◀ and ethanol (1.2.1).

Titrate while stirring with the 0,1 mol/l solution of potassium hydroxide (1.2.2) (see Note 2) until the indicator changes (the pink colour of the phenolphthalein persists for at least 10 seconds).

*Note 1.* The titrated ethanolic solution of potassium hydroxide (1.2.2) may be replaced by an aqueous solution of potassium or sodium hydroxide provided that the volume of water introduced does not induce phase separation.

*Note 2.* If the quantity of 0,1 mol/l potassium hydroxide solution required exceeds 10 ml, use the 0,5 mol/l solution.

*Note 3.* If the solution becomes cloudy during titration, add enough of the solvents (1.2.1) to give a clear solution.

1.5. **Acidity: expressed as percentage of oleic acid**

Acidity as a percentage by weight is equal to:

$$V \times c \times \frac{M}{1000} \times \frac{100}{m} = \frac{V \times c \times M}{10 \times m}$$

where:

V = the volume of titrated potassium hydroxide solution used, in millilitres;

c = the exact concentration in moles per litre of the titrated solution of potassium hydroxide used;

M = the molar weight in grams per mole of the acid used to express the result (= 282);

m = the weight in grams of the sample.

**▼C1**

Take as the result, the arithmetic mean ►**M6** of two calculations ◀ carried out.

**▼B***ANNEX III***DETERMINATION OF PEROXIDE VALUE**

## 1. SCOPE

This Standard describes a method for the determination of the peroxide value of oils and fats.

## 2. FIELD OF APPLICATION

This Standard is applicable to animal and vegetable oils and fats.

## 3. DEFINITION

The peroxide value is the quantity of those substances in the sample, expressed in terms of milliequivalents of active oxygen per kilogram, which oxidize potassium iodide under the operating conditions described.

## 4. PRINCIPLE

Treatment of the test portion, in solution in acetic acid and chloroform, by a solution of potassium iodide. Titration of the liberated iodine with standardized sodium thiosulphate solution.

## 5. APPARATUS

All the equipment used shall be free from reducing or oxidizing substances.

*Note:* Do not grease ground surfaces.

## 5.1. 3 ml glass scoop.

## 5.2. Flasks, with ground necks and stoppers, of about 250 ml capacity, dried beforehand and filled with a pure, dry inert gas (nitrogen or, preferably, carbon dioxide).

## 5.3. 25- or 50-ml burette, graduated in 0,1 ml.

## 6. REAGENTS

## 6.1. Chloroform, analytical reagent quality, freed from oxygen by bubbling a current of pure, dry inert gas through it.

## 6.2. Glacial acetic acid, analytical reagent quality, freed from oxygen by bubbling a current of pure, ►C1 dry inert gas ◀ through it.

## 6.3. Potassium iodide, saturated aqueous solution, recently prepared, free from iodine and iodates.

## 6.4. Sodium thiosulphate, 0,01 or 0,002 ►C1 Mol/L accurately ◀ standardized aqueous solution, standardized just before use.

## 6.5. Starch solution, 10 g/l aqueous dispersion, recently prepared from natural soluble starch.

## 7. SAMPLE

Take care that the sample is taken and stored away from the light, kept cold and contained in completely filled glass containers, hermetically sealed with ground-glass or cork stoppers.

## 8. PROCEDURE

The test shall be carried out in diffuse daylight or in artificial light. Weigh in a glass scoop (5.1) or, failing this, in a flask (5.2), to the nearest 0,001 g, a mass of the sample in accordance with the following table, according to the expected peroxide value:

**▼B**

Expected peroxide value (meq)	Weight of test portion (g)
0 to 12	5,0 to 2,0
12 to 20	2,0 to 1,2
20 to 30	1,2 to 0,8
30 to 50	0,8 to 0,5
50 to 90	0,5 to 0,3

Unstopper a flask (5.2) and introduce the glass scoop containing the test portion. Add 10 ml of chloroform (6.1). Dissolve the test portion rapidly by stirring. Add 15 ml of acetic acid (6.2), then 1 ml of potassium iodide solution (6.3). Insert the stopper quickly, shake for one minute, and leave for exactly five minutes away from the light at a temperature from 15 to 25 °C.

Add about 75 ml of distilled water. Titrate the liberated iodine with the sodium thiosulphate solution ►C1 (6.4) (0,002 Mol/L solution for expected values less than 12, and 0,01 Mol/L solution ◀ for expected values above 12) shaking vigorously, using starch solution (6.5) as indicator.

Carry out two determinations on the same test sample.

Carry out simultaneously a blank test. If the result of the blank exceeds 0,05 ml of ►C1 0,01 mol/L sodium ◀ thiosulphate solution (6.4), replace the impure reagents.

#### 9. EXPRESSION OF RESULTS

The peroxide value (PV), expressed in milliequivalents of active oxygen per kilogram, is given by the formula:

$$PV = \frac{V \times T \times 1000}{m}$$

where:

V = the number of ml of the standardized sodium thiosulphate solution (6.4) used for the test, corrected to take into account the blank test;

T = ►C1 the exact molarity ◀ of the sodium thiosulphate solution (6.4) used;

m = the weight in g, of the test portion.

Take as the result the arithmetic mean of the two determinations carried out.

▼B

## ANNEX IV

DETERMINATION OF ALIPHATIC ALCOHOLS CONTENT BY  
CAPILLARY GAS CHROMATOGRAPHY

## 1. OBJECT

The procedure describes a method for the determination ►C1 of aliphatic ◀ alcohols content in oils and fats.

## 2. PRINCIPLE OF THE METHOD

The fatty substance, with 1-eicosanol added as internal ►C1 standard, is saponified with ethanolic potassium hydroxide and then the unsaponifiable matter extracted with diethyl ether. ◀

The alcoholic fraction is separated from the unsaponifiable matter by chromatography on a layer of potassium hydroxide impregnated silica gel; the alcohols recovered from the silica gel are transformed into trimethylsilyl ethers and analyzed by capillary gas chromatography.

## 3. APPARATUS

- 3.1. 250 ml round-bottom flask with reflux condenser and ground glass joints.
- 3.2. Separating funnels of 500 ml capacity.
- 3.3. Flasks of 250 ml capacity.
- 3.4. Chromatographic tank for thin-layer chromatographic analysis, for glass plates of dimensions 20 × 20 cm.
- 3.5. UV light ►C1 of wavelength ◀ 366 or 254 nm, for examination of TLC plates.
- 3.6. Microsyringe to deliver 100 µl and 500 µl.
- 3.7. Sintered glass filtering funnel with porous frit G 3 ►C1 (porosity 15 to 40 µm) ◀ of approximate diameter 2 cm and approximate height 5 cm suitable for filtering under vacuum and 12/21 ground male joint.
- 3.8. Vacuum flask of 50 ml capacity with 12/21 ground glass female joint for use with filter funnel (3.7).
- 3.9. Test tube of 10 ml capacity with conical bottom and plug.
- 3.10. Gas chromatograph for use with a capillary column, and provided with a splitting system composed of:
  - 3.10.1. thermostatic chamber for columns (column oven) to hold the temperature desired with a precision of ± 1 °C;
  - 3.10.2. thermostatic vaporization assembly (injection port) with ►C1 silanized ◀ coated glass;
  - 3.10.3. flame ionization detector, and converter amplifier;
  - 3.10.4. recorder-integrator for operation with the converter-amplifier (3.10.3), with response time not exceeding one second and with variable paper-speed.
- 3.11. Glass or fused silica capillary column, of length 20 to 30 m, internal diameter 0,25 to 0,32 mm, with SE-52 or SE-54 liquid phase or equivalent, with a film thickness between 0,10 and 0,30 µm.
- 3.12. Microsyringe for gas chromatography, of 10 µl capacity with hardened needle.

## 4. REAGENTS

- 4.1. Potassium hydroxide, approximately ►C1 2 mol/L ethanolic solution ◀: 130 g potassium hydroxide (minimum concentration 85 %) is dissolved, with cooling, in 200 ml distilled water and then made up to one litre with ethanol. The solution should be stored in a well-stoppered dark coloured glass bottle.
- 4.2. ►C1 Diethyl ether ◀, pure for analysis.
- 4.3. Anhydrous sodium sulphate, pure for analysis.

**▼B**

- 4.4. Silica gel TLC glass plates, ►C1 without fluorescence ◀ indicator, of thickness 0,25 mm (may be obtained commercially prepared).
- 4.5. Potassium hydroxide, approximately ►C1 0,2 mol/L ethanolic solution ◀; 13 g of potassium hydroxide are dissolved in 20 ml of distilled water and made up to one litre with ethanol.
- 4.6. Benzene, for chromatography. (see 5.2.2).
- 4.7. Acetone, for chromatography. (see 5.2.2).
- 4.8. Hexane, for chromatography. (see 5.2.2).
- 4.9. ►C1 Diethyl ether ◀, for chromatography. (see 5.2.2).
- 4.10. Chloroform, for chromatography.
- 4.11. Reference solution for thin layer chromatography: mixture of 5 % C<sub>20</sub> to C<sub>28</sub> alcohols in chloroform.
- 4.12. 0,2 % solution of 2,7-dichlorofluorescein in ethanol. This is made slightly basic by adding a few drops of ►C1 2 mol/L potassium hydroxide ◀ solution.
- 4.13. Anhydrous pyridine, for chromatography.
- 4.14. Hexamethyldisilazane.
- 4.15. Trimethylchlorosilane.
- 4.16. Standard solutions of trimethylsilyl ethers of aliphatic alcohols from C<sub>20</sub> to C<sub>28</sub>. They may be prepared from mixtures of pure alcohols at the time they are required for use.
- 4.17. A 0,1 % (m/v) solution of 1-eicosanol in CHCl<sub>3</sub> (internal standard).
- 4.18. Carrier gases: hydrogen and helium, pure for gas chromatography.
- 4.19. Auxiliary gases:
  - hydrogen, pure for gas chromatography,
  - air, pure for gas chromatography.

## 5. PROCEDURE

- 5.1. Preparation of unsaponifiable matter.
  - 5.1.1. Using a 500 µl microsyringe place, into a 250 ml round-bottom flask, a volume of 0,1 % 1-eicosanol ►C1 (1-heneicosanol ◀ may also be used) solution (4.17) containing a quantity of 1-eicosanol approximately equal to 10 % of the aliphatic alcohol content in that portion of sample to be taken for analysis. For example, to 5 g of sample add 250 µl of the 0,1 % 1-eicosanol solution if olive oil ►M6 ◀ ►C1 is being analysed, 1 500 µl if the sample is olive residue oil. Evaporate the internal standard solution to dryness under N<sub>2</sub>. ◀  
  
Quantitatively weigh into the flask approximately 5 g of dry, filtered sample.
    - 5.1.2. 50 ml of ►C1 mol/L potassium hydroxide ◀ ethanolic solution are added, reflux condenser is fitted and the apparatus ►C1 heated to gently boiling ◀ on steam bath and stirred continuously throughout the heating process until saponification has taken place (the solution becomes clear). Heating is continued for a further 20 minutes and then 50 ml of distilled water are added through the condenser, the condenser is ►C1 then disconnected ◀ and the flask is cooled to approximately 30 °C.
    - 5.1.3. The contents of the flask are quantitatively transferred to a separating funnel of ►C1 500 ml capacity, and the flask rinsed with 2 x 25 ml distilled water. Approximately 80 ml of diethyl ether are added, the whole shaken vigorously for 30 seconds and the two phases left to separate (Note 1). ◀

**▼C1**

The lower aqueous phase is transferred to a second funnel. Two further extractions are effected on the aqueous phase, in the same manner, using 60 to 70 ml diethyl ether each time.

**▼B**

*Note 1.* Emulsions may be eliminated by adding, using as a spray, small quantities of ethyl alcohol or methyl alcohol.

▼B

5.1.4. ►C1 The diethyl ether ◀ extracts are combined in a separating funnel and washed with distilled water (50 ml at a time) until the washing water gives a neutral reaction.

►C1 Discard the aqueous phase, dry the ether phase with ◀ anhydrous sodium sulphate and filter, into a flask of 250 ml capacity which has been weighed beforehand, the funnel and filter being washed with small quantities of ►C1 diethyl ether ◀ which are added to the total.

5.1.5. The ether is evaporated with ►C1 gentle heating ◀ to a few ml and then dried under a slight vacuum or under a current of nitrogen; drying is finished in an oven at 100 °C for approximately 15 minutes and the residue weighed after cooling in ►C1 a desiccator. ◀

5.2. Separation of alcoholic fractions.

5.2.1. Preparation of basic ►C1 TLC plates (4.4). The plates are immersed completely, in 0,2 mol/L potassium hydroxide solution (4.5) for 10 seconds, and then left to dry under a hood for two hours, and finally placed ◀ in an oven at 100 °C for one hour.

The plates are taken from the oven and stored in a ►C1 calcium chloride desiccator ◀ until required for use. The plates thus treated must be used within two weeks.

*Note 2.* When basic silica gel plates are used for separation of the alcoholic fraction, there is no need for the unsaponifiable substances to be treated ►C1 with  $Al_2O_3$  ◀. It follows that all acid compounds (fatty acids and others) are retained at the origin thereby obtaining both aliphatic alcohol and terpenic alcohol bands which are both separated distinctly from the sterol band.

5.2.2. ►M6 A solution of 65:35 by volume of hexane and ethyl ether is introduced into the development chamber to an approximate depth of 1 cm. (1). ◀ The tank is closed and left for not less than half an hour to allow equilibration between vapour and liquid. Strips of filter paper dipping into the eluent may be affixed to the inside surfaces of the tank to reduce the development time by approximately one-third and obtain more uniform, regular elution of the components.

*Note 3.* The developing solution must be replaced for each analysis in order to obtain reproducible developing conditions.

5.2.3. An approximately 5 % solution of unsaponifiable matter (5.1.5) in chloroform is prepared ►C1 and 300 µl of the solution is streaked as a uniform strip of minimum thickness, by means of the microsyringe of 100 µl capacity, on a TLC plate approximately 2 cm from the bottom of the TLC plate. Aligend with the strip, 2 to 3 µl of the aliphatic alcohol reference solution (4.11) are spotted ◀ for the identification of the aliphatic alcohol band after development has been completed.

5.2.4. The plate is placed inside the development tank as stated in 5.2.2. The temperature shall be kept between 15 and 20 °C. The tank is closed immediately, and the sample is left to elute until the front of the solvent has reached a distance 1 cm from the top of the plate. The plate is then removed from the development tank and the solvent evaporated under a hot air current or the plate is left for a while under the hood.

5.2.5. The plate is sprayed lightly and evenly with the solution of 2,7-dichloro-fluorescein when the plate is observed under ultra violet light, the aliphatic alcohol band is identified by comparison to the aliphatic alcohols in the band immediately above that, which is the triterpenic alcohol band, are outlined together.

*Note 4.* The requirement ►C1 for the removal of the ◀ aliphatic alcohol band and the triterpenic alcohol band together is determined by the possible migration of some aliphatic alcohols into the triterpenic alcohol band.

5.2.6. The silica gel enclosed ►C1 in the area outlined is scraped off with a metal spatula. The material removed is broken into fine fragments, and introduced into a filter funnel (3.7), 10 ml of hot chloroform are added. The contents are mixed ◀ thoroughly with the metal spatula and filtered under vacuum, the filtrate being collected in the flask (3.8) which is connected to the filter funnel.

(1) In these special cases, a 95:5 by volume eluent mixture of benzene and acetone will have to be used to obtain good band separation



▼B

The residue inside the funnel is washed  $3 \times 10$  ml with ethyl ether collecting the filtrate in the same flask fitted to the funnel. The filtrate is evaporated to a volume of approximately 4 to 5 ml and the residual ►C1 solution is transferred into a test tube of 10 ml capacity (3.9) which has been weighed beforehand; the test tube is dried by light heating under a gentle nitrogen current. The residue is redissolved with a few drops of acetone, dried again, the placed in an oven at 105 °C for 10 minutes, removed and cooled in the desiccator and weighed. ◀

The residue inside the test tube is composed of the alcoholic fraction.

- 5.3. Preparation of ►C1 trimethylsilyl ◀ ethers.
- 5.3.1. The reagent for silylation, consisting of a mixture of 9:3:1 by volume (Note 5) of pyridine-hexamethyldisilazane-trimethylchlorosilane in the proportion of 50 µl for each milligram of alcohols, is added to the test tube containing the alcoholic fraction, avoiding all absorption of moisture (Note 6).

*Note 5.* Solutions ready for use are commercially available; silanizing reagents such as N, 0-bis (trimethylsilyl) trifluoroacetamide + 1 % trimethylchlorosilane for mixing with the same volume of anhydrous pyridine.

- 5.3.2. The test tube is stoppered and shaken carefully without overturning until the alcohols have been ►C1 dissolved ◀. It is then left for at least 15 minutes at room temperature and subsequently centrifuged for some minutes; the clear solution is ready for gas chromatographic analysis.

*Note 6.* Any formation of slight opalescence is normal and causes no interference. The formation of a white flocculate or the appearance of a pink colouring are signs of the presence of moisture or the deterioration of the reagent. In this case the test shall be repeated.

- 5.4. Gas chromatography analysis.
- 5.4.1. Preliminary operations and conditioning of the capillary column.
- 5.4.1.1. The capillary column is fitted inside the gas chromatograph by connecting the beginning of the column to the evaporator which is connected to the splitting system and the end of the column to the detector.

General checking of the gas chromatography assembly is performed (tightness of gas fittings, efficiency of the detector, efficiency of the splitting system and of the recording system, etc.).

- 5.4.1.2. Capillary columns being used for the first time should be conditioned. A little carrier gas is caused to flow through the capillary column and then the gas chromatography assembly is switched on and ►C1 heated gradually until ◀ a temperature not less than 20 °C above the operating temperature (see Note 7) is attained. That temperature is held for not less than two hours and then the assembly is brought to the operating conditions (regulation of gas flow, split flame ignition, connection to the electronic recorder, adjustment of the temperature of the capillary column oven, the detector and the injector, etc.) and the signal is adjusted to a sensitivity not less than twice the highest level contemplated for the execution of the analysis. The base line tracing shall be linear, devoid of spikes of whatever nature and shall show no signs of drift.

Negative rectilinear drift is indicative of imperfect tightness of column connections whereas a positive drift is indicative of insufficient conditioning of the column.

*Note 7.* The temperature of conditioning shall be at least 20 °C less than the maximum temperature contemplated for the liquid phase employed.

- 5.4.2. Selection of operating conditions.
- 5.4.2.1. General operating conditions are as follows:
- column temperature: the initial isotherm is set at 180 °C for eight minutes and then programmed at 5 °C/minute to 260 °C and a further 15 minutes at 260 °C,
  - temperature of evaporator: 280 °C,
  - temperature of detector: 290 °C,

▼**B**

- linear velocity of carrier gas: helium 20 to 35 cm/s, hydrogen 30 to 50 cm/s,
- splitting ratio: 1:50 at 1:100,
- sensitivity of instrument: 4 to 16 times the minimum attenuation,
- sensitivity of recording: 1 to 2 mV fs,
- paper speed: 30 to 60 cm/h,
- quantity of substance injected: 0,5 to 1 µl of TMSE solution.

The above conditions may be modified according to the characteristics of the column and of the gas chromatograph in order that chromatograms satisfying the following conditions be obtained:

- alcohol retention time  $C_{26}$  shall be  $18 \pm 5$  minutes,
- the alcohol  $C_{22}$  peak shall be  $80 \pm 20$  % of the full scale value for olive oil and  $40 \pm 20$  % of the full scale value for seed oil.

5.4.2.2. The aforesaid requirements are checked by repeated injection of the standard TMSE mixture of alcohols and the operating conditions are adjusted to yield the best possible results.

5.4.2.3. The parameters for the integration of peaks shall be set so that a correct appraisal of the areas of the peaks considered is obtained.

5.4.3. Execution of analysis.

5.4.3.1. Using the microsyringe of 10 µl capacity draw in 1 µl of hexane followed by 0,5 µl of air and subsequently 0,5 to 1 µl of the sample solution; the plunger of the microsyringe is raised to empty the needle.

The needle is introduced through the septum of the injection assembly and after one to two seconds the solution is injected rapidly and the needle extracted slowly after approximately five seconds.

5.4.3.2. Recording is effected until the TMSE of the alcohols present have been eluted completely. The base line shall always correspond to the requirements of 5.4.1.2.

5.4.4. Identification of peaks.

The identification of individual peaks is effected according to the retention times and by comparison with the standard TMSE mixture, analyzed under the same conditions.

A chromatogram of the alcoholic fraction of a virgin olive oil is shown in Figure 1.

5.4.5. Quantitative appraisal.

5.4.5.1. The peak areas of 1-eicosanol and of the aliphatic alcohols  $C_{22}$  to  $C_{28}$  are calculated by electronic integration.

5.4.5.2. The contents of each alcohol, expressed in mg/ ►**M6** 1 000 ◀ g fatty substance are calculated as follows:

$$\text{alcohol } x = \frac{A_x \cdot m_s \cdot \text{►M6 1 000 ◀}}{A_s \cdot m}$$

where:

$A_x$  = area of the alcohol peak x ►**M6** ————— ◀;

$A_s$  = area of 1-eicosanol ►**M6** ————— ◀;

$m_s$  = mass of 1-eicosanol in milligrams;

$m$  = mass of sample drawn for determination, in grams.

## 6. EXPRESSION OF RESULTS

The contents of the individual aliphatic alcohols in mg/ ►**M6** ►**C2** 1 000 ◀ ◀ g of fatty substance and the sum of the 'total aliphatic alcohols' are reported.

**▼B**

## APPENDIX

*Determination of the linear velocity of the gas*

1 to 3  $\mu\text{l}$  of methane or propane are injected into the gas chromatograph set at normal operating conditions and the time taken for the methane or propane to flow through the column from the instant of injection to the instant the peak elutes ( $t_M$ ) is measured using a stop clock.

The linear velocity, in cm/s is given by  $L/t_M$ , where L is the length of the column, in centimetres, and  $t_M$  is the time, in seconds, measured by the stop clock.

**▼M6**  
**▼C2**

Figure 1 — Chromatogram of the alcoholic fraction of a virgin olive oil

- |                  |                  |
|------------------|------------------|
| 1 = Eicosanol    | 5 = Pentacosanol |
| 2 = Decosanol    | 6 = Hexacosanol  |
| 3 = Tricosanol   | 7 = Heptacosanol |
| 4 = Tetracosanol | 8 = Octacosanol. |

▼**B**

## ANNEX V

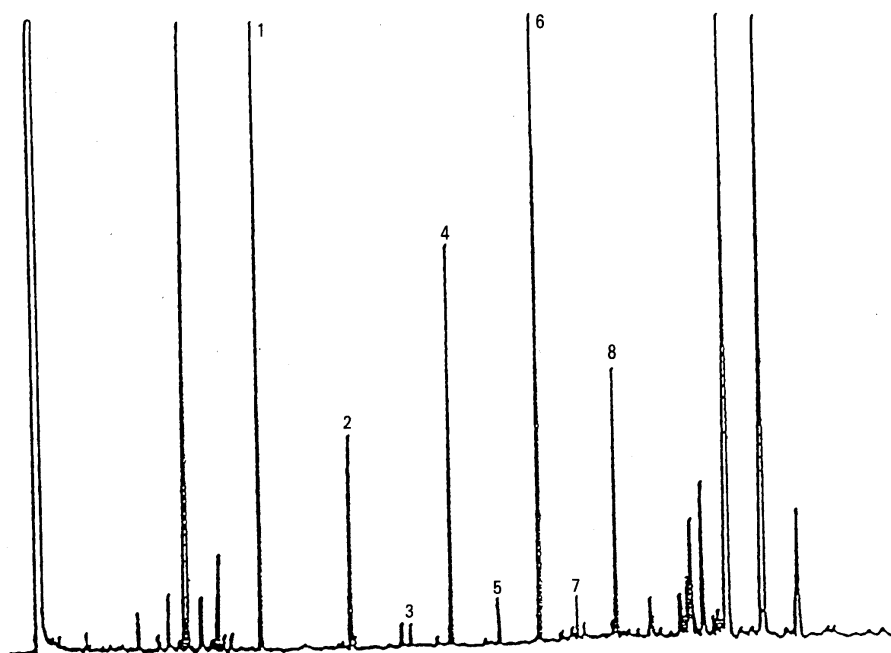
**DETERMINATION OF THE COMPOSITION AND CONTENT OF STEROLS BY CAPILLARY-COLUMN GAS CHROMATOGRAPHY**

## 1. SCOPE

The method describes a procedure for determining the individual and total sterols content of fatty substances.

## 2. PRINCIPLE OF THE METHOD

The fatty substance, with added  $\alpha$ -cholestanol as an internal standard, is saponified with potassium hydroxide in ethanolic solution and the unsaponifiables are then extracted with ►**C1** diethyl ether ◀.

The sterol fraction is separated from the unsaponifiable extract by chromatography on a basic silica gel plate. The sterols recovered from the silica gel are transformed into trimethyl-silyl ethers and are analysed by capillary-column gas chromatography.

## 3. APPARATUS

- 3.1. 250 ml flask fitted with a reflux condenser having ground-glass joints.
- 3.2. 500 ml separating funnels.
- 3.3. 250 ml flasks.
- 3.4. Complete apparatus for analysis by thin-layer chromatography using 20 × 20 cm glass plates.
- 3.5. Ultraviolet lamp having a wavelength of 366 or 254 nm.
- 3.6. 100  $\mu$ l and 500  $\mu$ l microsyringes.
- 3.7. A cylindrical filter funnel with a G3 porous septum (porosity 15 to 40  $\mu$ m) of diameter approximately 2 cm and a depth of some 5 cm, with an attachment suitable for filtration under vacuum and a 12/21 male ground glass joint.
- 3.8. 50 ml vacuum conical flask with a 12/21 ground-glass female joint which can be fitted to the filter funnel (3.7).
- 3.9. A 10 ml test tube with a tapering bottom and a sealing stopper.
- 3.10. Gas chromatograph suitable for use with a capillary column, provided with a splitting system consisting of:
  - 3.10.1. a thermostatic chamber for columns capable of maintaining the desired temperature with an accuracy of  $\pm 1$  °C;
  - 3.10.2. a temperature-adjustable vaporization unit with a persilanized glass vapourizing element;
  - 3.10.3. a flame ionization detector and converter-amplifier;
  - 3.10.4. an integrator-recorder suitable for use with the converter-amplifier (3.10.3) having a response time of not more than one second and a variable paper speed.
- 3.11. A glass or fused-silica capillary column of length 20 to 30 m, internal diameter 0,25 to 0,32 mm, entirely coated with SE-52 or SE-54 liquid or equivalent in a uniform thickness between 0,10 and 0,30  $\mu$ m.
- 3.12. A 10  $\mu$ l gas chromatography microsyringe with a hardened needle.

## 4. REAGENTS

- 4.1. Potassium hydroxide, ►**C1** approximately 2 mol/L ethanolic solution. ◀ Dissolve 130 g of potassium hydroxide ►**C1** (minimum concentration 85 %) ◀ with cooling in 200 ml of distilled water and then make up to one litre with ethanol. Keep the solution in well-stoppered dark glass bottles.
- 4.2. ►**C1** Diethyl ether ◀, analytical purity.
- 4.3. Anhydrous sodium sulphate, analytical purity.
- 4.4. Glass plates coated with silica gel, without fluorescence indicator, thickness 0,25 mm (commercially available ready for use).

▼**B**

- 4.5. Potassium hydroxide, ►**C1** 0,2 mol/L ◀ ethanolic solution. Dissolve 13 g of potassium hydroxide in 20 ml of distilled water and make up to one litre with ethanol.
- 4.6. Benzene, for chromatography. (See 5.2.2)
- 4.7. Acetone, for chromatography. (See 5.2.2)
- 4.8. Hexane, for chromatography. (See 5.2.2)
- 4.9. ►**C1** Diethyl ether ◀, for chromatography. (See 5.2.2)
- 4.10. Chloroform, analytical purity. (See 5.2.2)
- 4.11. Reference solution for thin-layer chromatography: cholesterol or phytosterols, ►**M6** 2 % ◀ solution in chloroform.
- 4.12. 2,7-dichlorofluorescein, 0,2 % ethanolic solution. Make slightly basic by adding a few drops of ►**C1** 2 mol/L ◀ alcoholic potassium hydroxide solution.
- 4.13. Anhydrous pyridine, for chromatography.
- 4.14. Hexamethyl disilazane.
- 4.15. Trimethylchlorosilane.
- 4.16. Reference solutions of sterol trimethylsilyl ethers. To be prepared at the time of use from pure sterols or mixtures of sterols obtained from oils containing them.
- 4.17. ►**C1**  $\beta$ -cholestanol ◀, 0,2 % solution (m/V) in chloroform (internal standard).
- 4.18. Carrier gas: hydrogen or helium, gas-chromatographic purity.
- 4.19. Auxiliary gases:
  - hydrogen, gas-chromatographic purity,
  - air, gas-chromatographic purity.

## 5. PROCEDURE

- 5.1. Preparation of the unsaponifiables.
  - 5.1.1. Using the 500  $\mu$ l microsyringe ►**C1** introduce, into a 250 ml flask a volume of 0,2 %  $\beta$ -cholestanol solution in chloroform (4.17) containing an amount of cholestanol corresponding to approximately 10 % of the sterol content of the sample aliquot to be taken for the determination. ◀ For example, for 5 g of sample add 500  $\mu$ l of the 0,2 %  $\alpha$ -cholestanol solution in the case of an olive oil and 1 500  $\mu$ l for ►**M6** ◀ olive-pomaca oil.

Evaporate to ►**C1** dryness in a current ◀ of nitrogen and then weigh accurately 5 g of the dry filtered sample into the same flask.

►**M6** Oils ◀ and fats containing appreciable quantities of cholesterol may show a peak having a retention time identical to cholestanol. If this occurs the sterol fraction will have to be analyzed in duplicate with and without internal standard ►**M6** or betulinol will have to be used instead of cholestanol ◀.

- 5.1.2. Add 50 ml of ►**C1** 2 mol/L ◀ ethanolic potassium hydroxide solution, fit the reflux condenser and heat to gentle boiling on a water bath with continuous vigorous stirring until saponification takes place (the solution becomes clear). Continue heating for a further 20 minutes, then add 50 ml of ►**C1** distilled water to the ◀ top of the condenser, detach the condenser and cool the flask to approximately 30 °C.
- 5.1.3. Transfer the contents of the flask quantitatively into a 500 ml separating funnel using several rinses of distilled water, amounting in all to about 50 ml. Add approximately 80 ml of ►**C1** diethyl ether ◀, shake vigorously for approximately 30 seconds and allow to settle (Note 1).

Separate off the lower aqueous phase collecting it in a second separating funnel. Perform two further extractions on the aqueous phase in the same way using 60 to 70 ml of ethyl ether on each occasion.

*Note 1.* Any emulsion can be destroyed by adding small quantities of ethyl or methyl alcohol by means of a spray.

- 5.1.4. Pool the ether extracts into a single separating funnel and wash with distilled water (50 ml at a time) until the wash water gives a neutral reaction.

## ▼B

When the wash water has been removed, dry with anhydrous sodium sulphate and ►C1 filter through anhydrous ◀ sodium sulphate into a previously weighed 250 ml flask, washing the funnel and filter with small quantities of ►C1 diethyl ether. ◀

- 5.1.5. Distil the ether down to a few ml, then bring to dryness under a slight vacuum or in a current of nitrogen, completing drying in a stove at 100 °C for approximately a quarter of an hour, and then weigh after cooling in a desiccator.

5.2. Separation of the sterol fraction.

- 5.2.1. Preparation of the basic plates. Immerse the silica gel plates (4.4) completely in the ►C1 0,2 mol/L ◀ ethanolic potassium hydroxide solution (4.5) for 10 seconds, then allow to dry in a fume cupboard for two hours and finally place ►C1 in an oven at ◀ 100 °C for one hour.

Remove from the stove and keep in a calcium chloride desiccator until required for use (plates treated in this way must be used within 15 days).

*Note 2.* When basic silica gel plates are used to separate the sterol fraction there is no need to treat the unsaponifiables with alumina. In this way all compounds of an acid nature (fatty acids and others) are retained on the spotting line and the sterols band is clearly separated from the aliphatic and triterpene alcohols band.

- 5.2.2. Place a 95:5 (v/v) benzene/acetone ►C1 mixture into the ◀ plate-developing chamber to a depth of approximately 1 cm. As an alternative a 65:35 (v/v) hexane/ethyl ether mixture may be used. Close the chamber with the appropriate cover and leave thus for approximately half an hour so that liquid-vapour equilibrium is established. Strips of filter paper dipping into the eluent may be placed on the internal surfaces of the chamber. This reduces developing time by approximately one-third and brings about more uniform and regular elution of the components.

*Note 3.* The developing mixture should be replaced for every test in order to achieve perfectly reproducible elution conditions.

- 5.2.3. Prepare an approximately 5 % solution of the unsaponifiables (5.1.5) in chloroform and, using the 100 µl microsyringe, streak a chromatographic plate ►C1 (5.2.1) with 300 µl ◀ approximately 2 cm from one end in a streak which is as thin and as uniform as possible. In line with the streak place 2 to 3 µl of the sterol reference solution (4.11) at one end of the plate so that the sterol band can be identified after developing.
- 5.2.4. Place the plate in the developing chamber prepared as specified in 5.2.2. The ambient temperature should be maintained between 15 and 20 °C. Immediately close the chamber with the cover and allow to elute until the solvent front reaches approximately 1 cm from the upper edge of the plate. Remove the plate from the developing chamber and evaporate the solvent in a flow of hot air or by leaving the plate for a short while under a hood.
- 5.2.5. Spray the plate lightly and uniformly with the 2,7-dichlorofluorescein solution. When the plate is observed under ultraviolet light the sterol band can be identified through being aligned with the stain obtained from the reference solution. Mark the limits of the band along the edges of the fluorescence with a black pencil.
- 5.2.6. Using a metal spatula scrape off the silica gel in the marked area. Place the finely comminuted material removed into the filter funnel (3.7). Add 10 ml of hot chloroform, mix carefully with the metal spatula and filter under vacuum, collecting the filtrate in the conical flask (3.8) attached to the filter funnel.

Wash the residue ►C1 in the funnel three times with diethyl ether ◀ (approximately 10 ml each time) collecting the filtrate in the same flask attached to the funnel. Evaporate the filtrate to a volume of 4 to 5 ml, transfer the residual solution to the previously weighed 10 ml test tube (3.9), evaporate to dryness by mild heating in a gentle flow of nitrogen, make up again using a few drops of acetone, evaporate again to dryness, place in a stove at 105 °C for approximately 10 minutes and then allow to cool in a desiccator and weigh.

The residue contained in the test tube consists of the sterol fraction.

- 5.3. Preparation of the trimethylsilyl ethers.

▼**B**

- 5.3.1. Add the silylation reagent, consisting of a 9:3:1 (v/v/v) mixture of pyridine/hexamethyl disilazane/trimethyl chlorosilane (Note 4) in the ratio of 50 µl for every milligram of sterols to the test tube containing the sterol fraction, avoiding any uptake of moisture (Note 5).

*Note 4.* Solutions which are ready for use are available commercially. Other silanizing reagents such as, for example, bis-trimethylsilyl, trifluor acetamide + 1 % trimethyl chlorosilane, which has to be diluted with an equal volume of anhydrous pyridine, are also available.

- 5.3.2. Stopper the test tube, shake carefully (without overturning) until the sterols are completely dissolved. Stand for at least 15 minutes at ambient temperature and then centrifuge for a few minutes. The clear solution is ready for gas chromatographic analysis.

*Note 5.* The slight opalescence which may form is normal and does not cause any interference. The formation of a white floc or the appearance of a pink colour are indicative of the presence of moisture or deterioration of the reagent. If these occur the test must be repeated.

- 5.4. Gas chromatographic analysis.

- 5.4.1. Preliminary operations, column packing.

- 5.4.1.1. Fit the column in the gas chromatograph, attaching the inlet end to the evaporator connected to the splitting system and the outlet end to the detector.

Carry out general checks on the gas chromatograph unit (leaks from the gas circuits, detector efficiency, efficiency of the splitting system and recording system, etc.).

- 5.4.1.2. If the column is being used for the first time it is recommended that it should be subjected to conditioning. Pass a gentle flow of gas through the column and then switch on the gas chromatography unit and begin gradual heating up to a temperature of at least 20 °C above the operating temperature (Note 6). Hold this temperature for at least two hours, then place the entire unit in operating mode (adjustment of gas flows and splitting, ignition of the flame, connection with the electronic recorder, adjustment of the column chamber, detector and injector temperature, etc.) and then record the signal with a sensitivity at least two times greater than that intended for the analysis. The course of the base line must be linear, without peaks of any kind, and must not drift.

A negative straight-line drift indicates leakage from the column connections; a positive drift indicates inadequate conditioning of the column.

*Note 6.* The conditioning temperature must always be at least 20 °C less than the maximum temperature specified for the stationary phase used.

- 5.4.2. Choice of operating conditions.

- 5.4.2.1. The guideline operating conditions are as follows:

- column temperature: 260 ± 5 °C,
- evaporator temperature: 280 °C,
- detector temperature: 290 °C,
- linear velocity of the carrier gas: helium 20 to 35 cm/s, hydrogen 30 to 50 cm/s,
- splitting ratio: from 1:50 to 1:100,
- instrument sensitivity: from 4 to 16 times the minimum attenuation,
- recording sensitivity: 1 to 2 mV f.s.,
- paper speed: 30 to 60 cm/hour,
- amount of substance injected: 0,5 to 1 µl of TMSE solution.

These conditions may be varied in the light of column and gas-chromatograph characteristics so as to obtain chromatograms which meet the following requirements:

- the retention time for β-sitosterol should be 20 ± 5 minutes,
- the campesterol peak should be: for olive oil (mean content 3 %) 15 ± 5 % of full scale; for soya oil (mean content 20 %) 80 ± 10 % of full scale,
- all the sterols present must be separated. In addition to being separated the peaks must also be completely resolved, i.e. the peak trace should return to the base line before leaving for the next peak. Incomplete resolution is however tolerated provided that the peak at TRR 1,02 can be quantified using the perpendicular.

▼B

## 5.4.3. Analytical procedure.

5.4.3.1. Using the 10 µl microsyringe take 1 µl of hexane, draw in 0,5 µl of air and then 0,5 to 1 µl of the sample solution. Raise the plunger of the syringe further so the needle is emptied. Push the needle through the membrane of the injection unit and after one to two seconds inject rapidly, then slowly remove the needle after some five seconds.

5.4.3.2. Continue recording until the TMSE of the sterols present are completely eluted

The base line must continue to meet the requirements (5.4.1.2).

## 5.4.4. Peak identification.

Identify individual peaks on the basis of retention times and by comparison with mixtures of sterol TMSE analysed under the same conditions.

The sterols are eluted in the following order: cholesterol, brassicasterol, 24-methylene cholesterol, campesterol, campestanol, stigmasterol, Δ 7-campesterol, Δ 5,23-stigmastadienol, ►C1 chlerosterol ◄, β-sitosterol, sitostanol, Δ 5-avenasterol, Δ 5,24-stigmastadienol ►C1, Δ 7-stigmasterol, ◄ Δ 7-avenasterol.

The retention times for sitosterol for SE-52 and SE-54 columns are shown in Table 1.

Figures 1 and 2 illustrate typical chromatograms for some oils.

## 5.4.5. Quantitative evaluation.

5.4.5.1. Calculate the areas of the ►C1 β-cholestanol ◄ and the sterol peaks using the integrator. Ignore peaks for any compounds which are not included among those listed in Table 1. The response coefficient for ►C1 β-cholestanol ◄ is to be equal to 1.

5.4.5.2. Calculate the concentration of each individual sterol in mg/100 g of fatty material as follows:

$$\text{sterol } x = \frac{A_x \cdot m_s \cdot 100}{A_s \cdot m}$$

where:

$A_x$  = peak area for sterol x ►M6 ————— ◄;

$A_s$  = area of the ►C1 β-cholestanol ◄ peak  
►M6 ————— ◄;

$m_s$  = mass of ►C1 β-cholestanol ◄ added, in milligrams;

$m$  = mass of the sample used for determination, in grams.

## 6. EXPRESSION OF THE RESULTS

6.1 Record individual sterol concentrations as mg/100 g of fatty material and their sum as 'total sterols'.

6.2 Calculate the percentage of each individual sterol from the ratio of the relevant peak area to the total peak area for sterols.

$$\% \text{ of sterol } x = \frac{A_x}{\Sigma A} \cdot 100$$

where:

$A_x$  = peak area for x;

$\Sigma A$  = total peak area for sterols.



▼**B**

## APPENDIX

*Determination of the linear velocity of the gas*

With the gas chromatograph set to normal operating conditions inject 1 to 3  $\mu\text{l}$  of methane (or propane) and measure the time taken by the gas to pass through the column from the time of injection to the time at which the peak appears ( $t_M$ ).

The linear velocity in cm/s is given by  $L/t_M$ , where L is the length of the column in centimetres and  $t_M$  is the measured time in seconds.

**Table I**

Relative retention times for sterols

Peak	Identification		Relative retention time	
			SE 54 column	SE 52 column
1	cholesterol	$\Delta$ -5-cholesten-3 $\beta$ -ol	0,67	0,63
2	cholestanol	5 $\alpha$ -cholestan-3 $\beta$ -ol	0,68	0,64
3	brassicasterol	[24S]-24-methyl- $\Delta$ -5,22-cholestadien-3 $\beta$ -ol	0,73	0,71
4	24-methylene-cholesterol	24-methylene- $\Delta$ -5,24-cholesten-3 $\beta$ -ol	0,82	0,80
5	campesterol	[24R]-24-methyl- $\Delta$ -5-cholesten-3 $\beta$ -ol	0,83	0,81
6	campestanol	[24R]-24-methyl-cholestan-3 $\beta$ -ol	0,85	0,82
7	stigmasterol	[24R]-24-ethyl- $\Delta$ -5,22-cholestadien-3 $\beta$ -ol	0,88	0,87
8	$\Delta$ -7-campesterol	[24R]-24-methyl- $\Delta$ -7-cholesten-3 $\beta$ -ol	0,93	0,92
9	$\Delta$ -5,23-stigmastadienol	[24R,S]-24-ethyl- $\Delta$ -5,23-cholestadien-3 $\beta$ -ol	0,95	0,95
10	chlrosterol	[24S]-24-ethyl- $\Delta$ -5,25-cholestadien-3 $\beta$ -ol	0,96	0,96
11	$\beta$ -sitosterol	[24R]-24-ethyl- $\Delta$ -5-cholestan-3 $\beta$ -ol	1,00	1,00
12	sitostanol	24-ethyl-cholestan-3 $\beta$ -ol	1,02	1,02
13	$\Delta$ -5-avenasterol	[24Z]-24-ethylidene-5-cholesten-3 $\beta$ -ol	1,03	1,03
14	$\Delta$ -5,24-stigmastadienol	[24R,S]-24-ethyl- $\Delta$ -5,24-cholestadien-3 $\beta$ -ol	1,08	1,08
15	$\Delta$ -7-stigmastenol	[24R,S]-24-Ethyl- $\Delta$ -7,24-cholestadien-3 $\beta$ -ol	1,12	1,12
16	$\Delta$ -7-avenasterol	[24Z]-24-ethyliden- $\Delta$ -7-cholesten-3 $\beta$ -ol	1,16	1,16

▼B

Figure 1

*Gas chromatogram of the sterol fraction of an unrefined olive oil*

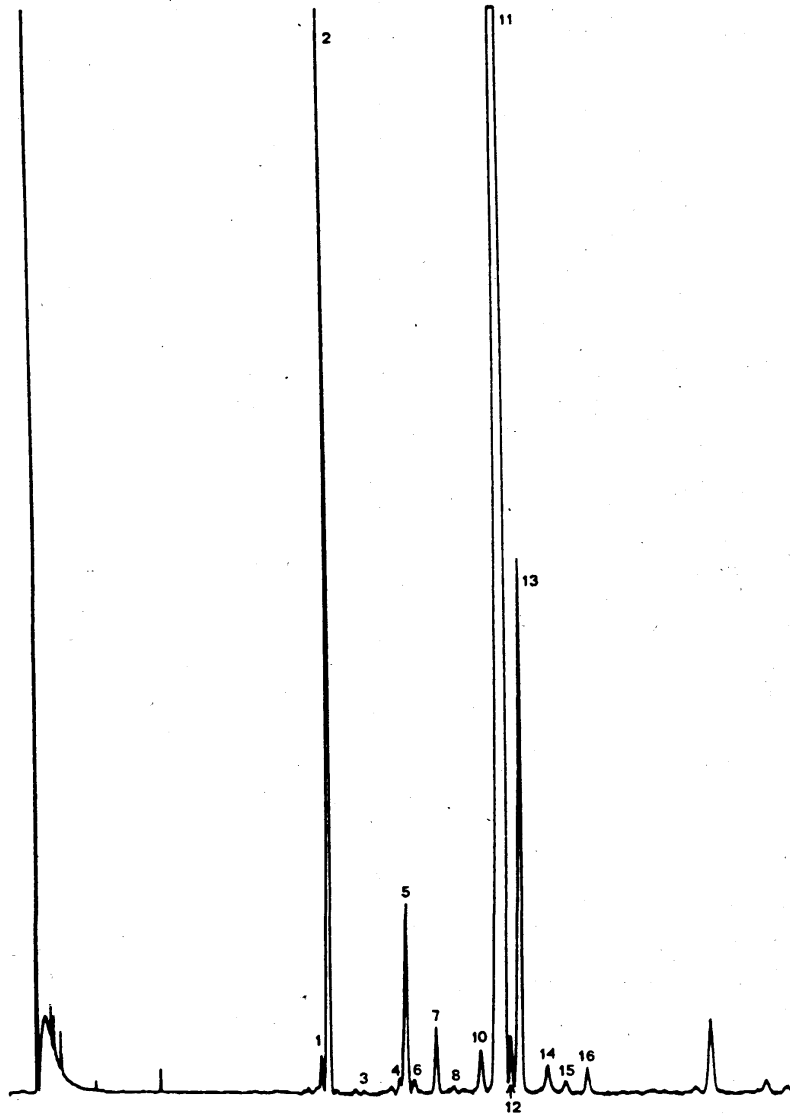

▼B

Figure 2

*Gas chromatogram of the sterol fraction of a refined olive oil*

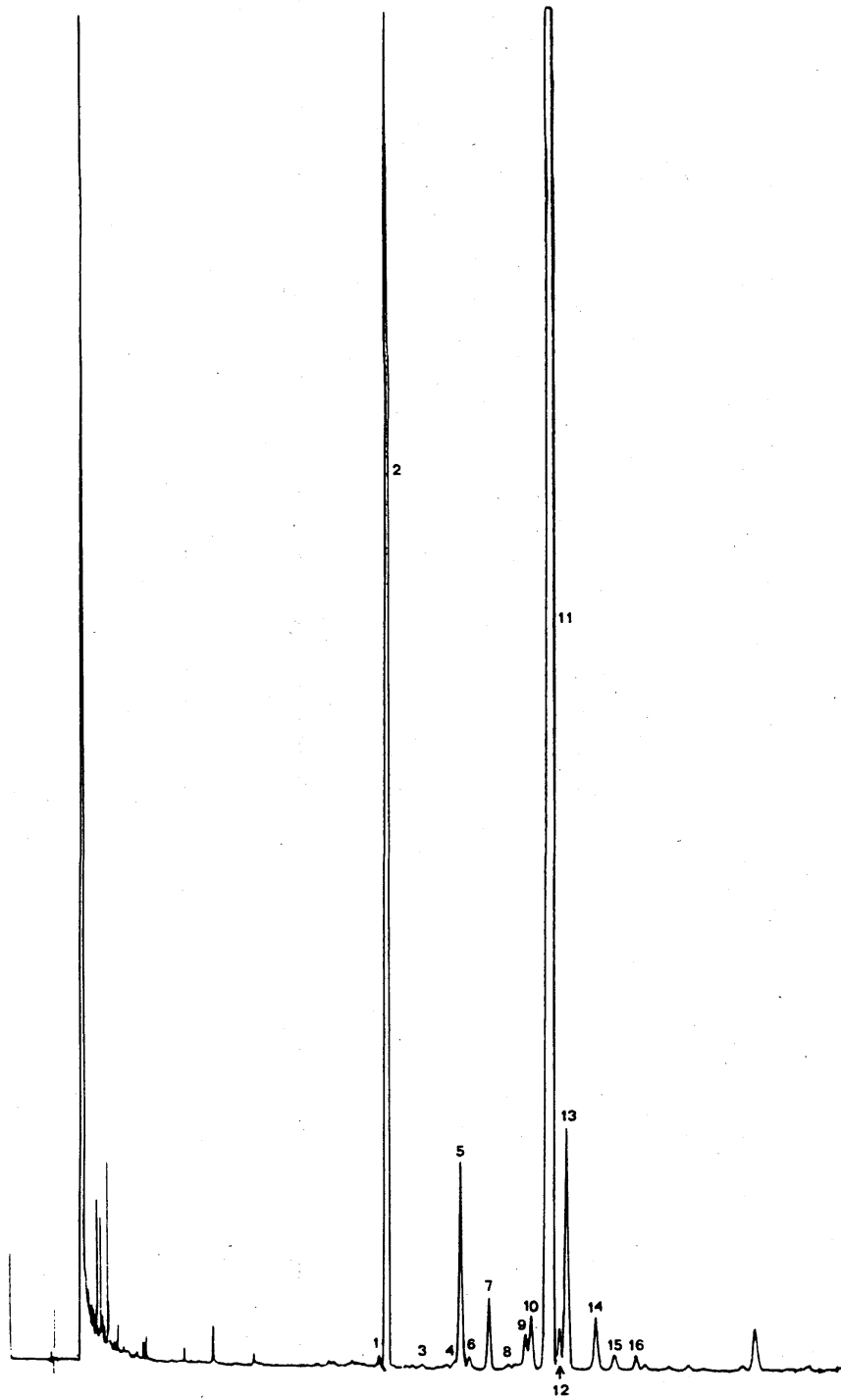



ANNEX VI

**DETERMINATION OF ERYTHRODIOL AND UVAOL**

INTRODUCTION

Erythrodiol (commonly understood as the glycols erythrodiol and uvaol together) is a constituent of the unsaponifiable fraction, characteristic of some types of fatty substances. It is found at considerably higher concentrations in solvent-extracted olive oil than in other oils, such as pressed olive oil and grape pip oil, which also contain it, and so its presence may demonstrate the presence of solvent-extract olive oil.

1. SCOPE

The method describes a procedure for detecting erythrodiol in fatty substances.

2. PRINCIPLE OF THE METHOD

The fatty substance is saponified with potassium ►C1 hydroxide in ethanolic solution. The unsaponifiable fraction is then extracted with diethyl ether ◀ and purified by passage over a column of alumina.

The unsaponifiables are subjected to thin-layer chromatography on a silica gel plate until the bands corresponding to the sterol and erythrodiol fractions are separated. The sterols and the erythrodiol recovered from the plate are transformed into trimethylsilyl ethers and the mixture is analysed by gas chromatography.

The result is expressed as the percentage of erythrodiol in the mixture of erythrodiol and sterols.

3. APPARATUS

- 3.1. The apparatus described in Annex V (determination of the content of sterols).

4. REAGENTS

- 4.1. The reagents described in Annex V (determination of the content of sterols).
- 4.2. Reference solution of erythrodiol, 0,5 % solution in chloroform.

5. PROCEDURE

5.1. **Preparation of the unsaponifiables.**

As described at paragraph 5.1.2 of Annex V.

5.2. **Separation of erythrodiol and the sterols.**

- 5.2.1. See paragraph 5.2.1 of Annex V.

- 5.2.2. See paragraph 5.2.2 of Annex V.

- 5.2.3. Prepare a 5 % solution of the unsaponifiables in chloroform.

Using the 0,1 ml microsyringe, streak a chromatographic plate with 0,3 ml of solution approximately 1,5 cm from the lower edge in a streak which is as thin and uniform as possible.

At one end of the plate place a few microlitres of the solutions of cholesterol and erythrodiol to serve as a reference.

- 5.2.4. Place the plate in the developing chamber prepared as specified in 5.2.1. The ambient temperature should be about 20 °C. Immediately close the chamber with the cover and allow to elute until the solvent front reaches approximately 1 cm from the upper edge of the plate. Remove the plate from the developing chamber and evaporate the solvent in a flow of hot air.
- 5.2.5. Spray the plate lightly and uniformly with the alcoholic 2,7-dichlorofluorescein solution. When the plate is observed under ultraviolet light the sterol and erythrodiol bands can be identified through being aligned with the references. Mark with a spot just outside the edges of the fluorescence.

**▼B**

5.2.6. Using a metal spatula scrape off the silica gel in the marked areas. Place the material from the plate in a 50 ml flask. Add 15 ml of hot chloroform, shake well and filter through a funnel with a sintered glass disc so that the silica gel is transferred to the filter. Wash three times with hot chloroform (10 ml each time) collecting the filtrate in a 100 ml flask. Evaporate the filtrate to a volume of 4 to 5 ml, transfer to a calibrated 10 ml conical-bottomed centrifuge tube, dry by gently heating in a current of nitrogen and weigh.

5.3. **Preparation of the trimethylsilyl esters**

As described in paragraph 5.3 of Annex V.

5.4. **Gas chromatographic analysis**

As described in paragraph 5.4 of the above method. The operating conditions of the gas chromatograph in analysis must be such as to perform the sterol analysis and separate the TMSE from the erythrodiol and uvaol.

Once the sample has been injected, continue recording until the sterols present, the erythrodiol and the uvaol have been eluted. Then identify the peaks (the retention times for erythrodiol and uvaol relative to  $\beta$ -sitosterol are about 1,45 and 1,55 respectively) and calculate the areas as for the sterols.

6. EXPRESSION OF THE RESULTS

$$\text{Erythrodiol \%} = \frac{A_1 + A_2}{A_1 + A_2 + \Sigma A_{\text{sterols}}} \times 100$$

where:

$A_1$  = peak area for erythrodiol ► **M6** ————— ◄;

$A_2$  = peak area for uvaol ► **M6** ————— ◄;

$\Sigma A_{\text{sterols}}$  = total peak area for sterols ► **M6** ————— ◄.

The result is expressed to one decimal place.

▼**B**

## ANNEX VII

**DETERMINATION OF FATTY ACIDS IN THE 2-POSITION IN THE TRIGLYCERIDES OF OILS AND FATS**

## 1. SCOPE

This Standard describes a method for the determination of the composition of that fraction of the fatty acids of an oil or fat which is esterified at the 2-position (or internal position) of the glycerol.

## 2. FIELD OF APPLICATION

This Standard is applicable to oils and fats having a melting point below 45 °C, owing to the peculiarities of the action of pancreatic lipase.

It is not applicable unreservedly to oils and fats containing substantial amounts of: fatty acids with 12 or fewer carbon atoms (coconut and palm-kernel oils, butterfat), or highly unsaturated fatty acids (with more than four double bonds) containing 20 or more carbon atoms (fish and marine animals oils), or fatty acids containing oxygenated groups, other than the acid group.

## 3. PRINCIPLE

Possible neutralization of acid oils and fats in a solvent. Purification by passing onto an alumina column. Partial hydrolysis of triglycerides by pancreatic lipase during a determined time. Separation of the formed monoglycerides by thin-layer chromatography and methanolysis of these monoglycerides. Analysis of these methyl esters by gas-liquid chromatography.

## 4. APPARATUS

- 4.1. 100 ml round-bottomed flask.
- 4.2. 25 ml round bottomed flask, with ground joint.
- 4.3. 1 m-long air condenser, to fit the flask 4.2.
- 4.4. 250 ml conical flask.
- 4.5. 50 ml beaker.
- 4.6. 500 ml separating funnel.
- 4.7. Chromatographic glass column, 13 mm internal diameter, 400 mm in length, fitted with a fritted glass disc and a tap.
- 4.8. 10 ml centrifuge tube, with ground glass stopper.
- 4.9. 5 ml burette, graduated in 0,05 ml.
- 4.10. 1 ml hypodermic syringe, fitted with a thin needle.
- 4.11. Microsyringe, to deliver drops of 3 to 4  $\mu$ l.
- 4.12. Spreader for thin-layer chromatography.
- 4.13. Glass plates for thin-layer chromatography, 20 × 20 cm.
- 4.14. Glass developing tank for thin-layer chromatography, with ground-glass lid, suitable for the 20 × 20 plates.
- 4.15. Spray for thin-layer chromatography.
- 4.16. Oven regulated at 103 ± 2 °C.
- 4.17. Thermostat regulatable between 30 and 45 °C to within 0,5 °C.
- 4.18. Rotary evaporator.
- 4.19. Vibrating electric shaker, allowing vigorous agitation of the centrifuge tube.
- 4.20. Ultraviolet lamp for the examination of the thin-layer plates.

*For the control of the lipase activity:*

- 4.21. pH meter.
- 4.22. Spiral stirrer.

**▼B**

- 4.23. 5 ml burette.
- 4.24. Stop-watch.

*For the possible preparation of the lipase:*

- 4.25. Laboratory stirrer, suitable for the dispersion and mixture of heterogeneous materials.

## 5. REAGENTS

- 5.1. *n*-hexane, or, failing this, light petroleum (bp 30 to 50 °C), chromatographic quality.
- 5.2. 2-propanol, or ethanol, 95 % (v/v), analytical reagent quality.
- 5.3. 2-propanol, or ethanol, 1/1 aqueous solution.
- 5.4. Diethyl ether, free from peroxides.
- 5.5. Acetone.
- 5.6. Formic acid, at least 98 % (m/m).
- 5.7. Developing solvent: mixture of *n*-hexane (5.1), diethyl ether (5.4) and formic acid (5.6) in proportions 70/30/1 (v/v/v).
- 5.8. Activated alumina for chromatography, neutral, grade Brockmann I.
- 5.9. Silica powder, with binder, of suitable quality for thin-layer chromatography.
- 5.10. Pancreatic lipase of suitable quality (Notes 1 and 2).
- 5.11. Sodium hydroxide, 120 g/l aqueous solution.
- 5.12. Hydrochloric acid, aqueous ► **C1** solution 6 Mol/l. ◀
- 5.13. Calcium chloride (CaCl<sub>2</sub>), 220 g/l aqueous solution.
- 5.14. Sodium cholate (enzymatic quality), 1 g/l aqueous solution.
- 5.15. Buffer solution: 1 M aqueous solution of *tris*-hydroxymethylamino-methane bring to pH 8 by addition of hydrochloric acid (5.12) (check by potentiometer).
- 5.16. Phenolphthalein, 10 g/l solution in 95 % (v/v) ethanol.
- 5.17. 2',7' -dichlorofluorescein, 2 g/l solution in 95 % (v/v) ethanol, rendered slightly alkaline by the addition of one drop of 1 N sodium hydroxide solution per 100 ml.

*For the control of the lipase activity:*

- 5.18. Neutralized oil.
- 5.19. Sodium ► **C1** hydroxide, 0,1 M ◀ aqueous solution.
- 5.20. Sodium cholate (enzymatic quality), 200 g/l aqueous solution.
- 5.21. Gum arabic, 100 g/l aqueous solution.

## 6. PREPARATION OF THE SAMPLE

If the sample has an acidity below 3 %, determined according to Annex II, purify directly over alumina according to 6.2.

If the sample has an acidity over 3 %, determined according to Annex II, neutralize by alkali in the presence of a solvent according to 6.1, then pass over alumina according to 6.2.

- 6.1. Neutralization by alkali in the presence of solvent

Into a separating funnel (4.6) introduce about 10 g of the crude oil and add 100 ml of hexane (5.1), 50 ml of 2-propanol (5.2), a few drops of phenolphthalein solution (5.16), and an amount of the sodium hydroxide solution (5.11) corresponding to the free acidity of the oil plus 0,3 % excess. Shake vigorously for one minute, add 50 ml of distilled water, shake again and leave to settle.

After separation, remove the bottom soap layer. Also remove any intermediate layers (mucilage, insoluble matter). Wash the hexane solution of the neutralized oil with successive 25 to 30 ml portions of the 2-propanol solution (5.3) until the pink colour of the phenolphthalein disappears.

**▼B**

Remove most of the hexane by distillation under vacuum in the rotary evaporator (4.18), dry the oil at 30 to 40 °C under vacuum with the help of a current of pure nitrogen until the hexane has been removed completely.

## 6.2. Purification through alumina

Prepare a suspension of 15 g of activated alumina (5.8) in 50 ml hexane (5.1) and pour it, while stirring, onto the chromatographic column (4.7). Let the alumina settle evenly, and allow the solvent level to fall to within 1 to 2 mm above the absorbent. Carefully pour onto the column a solution of 5 g of oil in 25 ml of hexane (5.1); collect the whole of the effluent from the column in a round-bottomed flask (4.1).

## 7. Preparation of the chromatographic plates

Thoroughly clean the glass plates (4.13) with ethanol, light petroleum and acetone to eliminate any trace of fatty matter.

In a conical flask (4.4) place 30 g of silica powder (5.9). Add 60 ml of distilled water. Stopper and shake vigorously for one minute. Transfer the slurry immediately to the spreader (4.12) and coat the clean plates with a layer 0,25 mm thick.

Dry the plates in the air for 15 minutes and then for an hour in the oven (4.16) at  $103 \pm 2$  °C. Cool the plates in a desiccator to room temperature before use.

Prepared plates are available in commerce.

## 8. PROCEDURE

## 8.1. Hydrolysis with pancreatic lipase.

Into the centrifuge tube (4.8) weigh about 0,1 g of the prepared sample, if the sample is a liquid oil proceed directly as below.

Add 20 mg of lipase (5.10) and 2 ml of the buffer solution (5.15). Shake well, but carefully, and then add 0,5 ml of the sodium cholate solution (5.14) and 0,2 ml of the calcium chloride solution (5.13). Close the tube with the ground stopper, shake cautiously (avoid wetting the stopper) and put the tube immediately in the thermostat (4.17) maintained at  $40 \pm 0,5$  °C and shake by hand for exactly one minute.

Remove the tube from the thermostat, and agitate vigorously by means of the electric shaker (4.19) for exactly two minutes.

Cool immediately in running water; add 1 ml of hydrochloric acid (5.12) and 1 ml of diethyl ether (5.4). Stopper and mix vigorously by means of the electric shaker. Allow to stand and remove the organic layer by means of the syringe (4.10), if necessary after centrifuging.

## 8.2. Separation of the monoglycerides by thin-layer chromatography

Apply the extract to the chromatographic plate with the microsyringe (4.11), about 1,5 cm from the bottom edge, in a thin, uniform line, as narrow as possible. Set the plate in the well-saturated developing tank (4.14) and develop with the developing solvent (5.7) at about 20 °C, up to about 1 cm from the top edge of the plate.

Dry the plate in the air at the temperature of the tank, and spray it with the 2',7'-dichlorofluorescein solution (5.17). Identify the monoglyceride band ( $R_f$  about 0,035) under ultraviolet light (4.20).

## 8.3. Analysis of the monoglycerides by gas-liquid chromatography

Remove the band obtained in 8.2 with the help of a spatula (avoid removing components remaining on the base line) and transfer in the methylation flask (4.2).

Treat the collected silica directly by the methods described in Annex X B alternative so as to convert the monoglycerides into methyl esters, and then examine the esters by gas chromatography as described in Annex X A.

## 9. EXPRESSION OF RESULTS

Calculate the fatty acid composition in the 2-position to one decimal place (Note 3).

## 10. NOTES

*Note 1:* Checking the activity of the lipase



**▼B**

Prepare an oil emulsion by shaking a mixture of 165 ml of the solution of gum arabic (5.21), 15 g of crushed ice and 20 ml of a neutralized oil (5.18) in a suitable agitator.

In a beaker (4.5) place 10 ml of this emulsion, followed successively by 0,3 ml of the sodium cholate solution (5.20) and 20 ml of distilled water.

Put the beaker into a thermostat maintained at  $37 \pm 0,5$  °C (Note 4); insert the electrodes of a pH meter (4.21) and a spiral stirrer (4.22).

By means of a burette (4.23) add dropwise the sodium hydroxide solution (5.19) until the pH reaches 8,5.

Add sufficient of an aqueous suspension of the lipase (see below).  
**►C1** As soon as **◄** the pH meter indicates a pH of 8,3, start the stop-watch (4.24) and drip in the sodium hydroxide solution (5.19) at such a rate as to maintain the pH at 8,3. Read off the volume of alkali solution consumed every minute.

Record the observations in the form of a graph, using the time readings as abscissae and the ml of alkali solution required to maintain the pH constant as ordinates. A linear graph should be obtained.

The lipase suspension mentioned above is a 1 per thousand (m/m) suspension in water. For each test sufficient of this suspension should be used so that about 1 ml of the alkali solution is consumed in four to five minutes. Usually about 1 to 5 mg of the powder is required.

The lipase unit is defined as the amount of enzyme which will liberate 10 µ-equivalents of acid per minute. Then the activity A of the powder used, measured in lipase units per mg, is given by the formula:

$$A = \frac{V \times 10}{m}$$

where V is the number of the sodium hydroxide solution (5.19) consumed per minute, calculated from the graph, m is the mass in mg, of the test portion of the powder.

*Note 2:* Preparation of the lipase

Lipases having satisfactory lipase activity are available commercially. But it is also possible to prepare them in the laboratory as follows:

Chill 5 kg of fresh pig pancreas to 0 °C; remove the surrounding solid fat and connective tissue and triturate in a blender so as to obtain a pasty fluid. Stir this paste with the stirrer (4.25) for four to six hours with 2,5 l of anhydrous acetone and centrifuge. Extract the residue thrice more with the same volume of acetone, then twice with 1/1 (V/V) mixture of acetone and diethyl ether, and twice with diethyl ether.

Dry the residue *in vacuo* for 48 hours to obtain a stable powder, which should be stored in a refrigerator.

*Note 3:* In every case it is advisable to determine the composition of the total fatty acids of the same sample, since the comparison with that of the acids in the 2-position will help in the interpretation of the figures obtained.

*Note 4:* The temperature of hydrolysis is set at 37 °C, as a liquid oil is being used. However, it is set at 40 °C for the test sample, so as to allow the examination of fats with melting points up to 45 °C.

▼B

## ANNEX VIII

▼C1

## DETERMINATION OF TRILINOLEIN CONTENT

▼B

## 1. SCOPE

Determination of composition of triglyceride in olive oils ►C1 in terms of their equivalent ◀ carbon number by high-performance liquid chromatography.

►C1 The present method ◀ describes a method of separation and quantitative determination of the triglyceride composition of vegetable oils in terms of their molecular weight and degree of unsaturation as a function of their equivalent carbon number (see Note 1).

## 2. FIELD OF APPLICATION

►C1 This method is ◀ applicable to all vegetable oils containing triglycerides of long-chain fatty acids. The method is especially applicable to the detection of the presence of small quantities of semi-drying oils (rich in linoleic acid) in vegetable oils containing oleic acid as the predominant unsaturated fatty acid, such as olive oil.

## 3. PRINCIPLE

Separation of triglycerides according to their equivalent carbon number by high-performance liquid chromatography (reversed phase polarity) and interpretation of the chromatograms.

## 4. APPARATUS

- 4.1. High-performance liquid chromatograph, allowing thermostatic control of column temperature.
- 4.2. Injection unit for 10 µl delivery.
- 4.3. Detector: differential refractometer. The full-scale sensitivity should be at least  $10^{-4}$  unit of refractive index.
- 4.4. Column: stainless steel tube 250 mm in length and of internal diameter 4,5 mm, packed with 5 µm diameter particles of silica with 22 to 23 % carbon in the form of octadecylsilane (Note 2).
- 4.5. Recorder and/or integrator.

## 5. REAGENTS

The reagents should be of analytical purity. Elution solvents should be degassed, and may be recycled several times without effect on the separations.

- 5.1. Chloroform.
- 5.2. Acetone.
- 5.3. Acetonitrile.
- 5.4. Elution solvent: acetonitrile + acetone (proportions to be adjusted to obtain the desired separation; begin with 50:50 mixture).
- 5.5. Solubilization solvent: acetone or 1:1 acetone-chloroform mixture.
- 5.6. Reference triglycerides: either commercial triglycerides (tripalmitin, triolein, etc.) may be used and the retention times thence plotted in accordance with the equivalent carbon number, or alternatively a reference chromatogram obtained from soya oil (see Notes 3 and 4 and Figures 1 and 2).

## 6. PREPARATION OF SAMPLES

A 5 % solution of the samples to be analysed is prepared by weighing  $0,5 \pm 0,001$  g of the sample into a 10 ml graduated flask and making up to 10 ml with the solubilization solvent (5.5).

**▼B**

## 7. PROCEDURE

- 7.1. Set up the chromatographic system. Pump elution solvent (5.4) at a rate of 1,5 ml/mm to purge the entire system. Wait until a stable base line is obtained.

Inject 10 µl of the sample prepared as in 6.

## 8. CALCULATION AND EXPRESSION OF RESULTS

Use the internal standardization method, i.e. assume that the sum of the areas of the peaks corresponding to the various triglycerides is equal to 100 %. Calculate the relative percentage of each triglyceride using the formula:

$$\% \text{ triglyceride} = \frac{\text{area of peak}}{\text{sum of peak areas}} \times 100$$

The result to be given to one decimal place.

*Note 1.* The elution order can be determined by calculating the equivalent carbon numbers, often defined by the relation  $ECN = CN - 2n$ , where CN is the carbon number and n is the number of double bonds; it can be calculated much more precisely by taking into account the origin of the double bond. If  $n_o$ ,  $n_i$  and  $n_{in}$  are the numbers of double bonds attributable to oleic, linoleic and linolenic acids respectively, the equivalent carbon number can be calculated by means of a relation of the formula:

$$ECN = CN - d_o n_o - d_i n_i - d_{in} n_{in}$$

where the coefficients  $d_o$ ,  $d_i$  and  $d_{in}$  can be calculated by means of the reference triglycerides. Under the conditions specified in this method the relation obtained will be close to:

$$ECN = CN - [2,60 n_o] - [2,35 n_i] - [2,17 n_{in}]$$

*Note 2.* Examples: Lichrosorb (Merck) RP18 Art 50333;

Lichrosphere or equivalent (Merck) 100 CH18 Art 50377.

*Note 3.* With several reference triglycerides it is also possible to calculate the resolution with respect to triolein,

$$\alpha = RT'/RT'_{\text{olein}}$$

by use of the reduced retention time  $RT' = RT - RT_{\text{solvent}}$ .

The graph of  $\log \alpha$  against f (number of double bonds) enables the retention values to be determined for all the triglycerides of fatty acids contained in the reference triglycerides — see Figure 2.

*Note 4.* The efficiency of the column should permit clear separation of the peak of trilinolein from the peaks of the triglycerides with an adjacent RT.

**▼M4**

*Note 5:* In order to permit clear separation of the peak of trillinolein from the adjacent peaks, crude olive-residue oil should be purified beforehand in accordance with point 6.2 of Annex VII or, alternatively:

200 µl of undiluted oil are absorbed in a silica column for liquid-solid extraction (type SEP PAC silica cartridge-waters port. No 51900).

The triglycerides are eluted with 20 ml anhydrous hexane for HPLC.

The eluted product is dried in a nitrogen flow and placed in Isopropanol or acetone (5 ml). 10-20 µl are injected into HPLC. For these two purification methods, the fatty acid composition of the oil must be checked to ensure that it is the same before and after purification. If it is not the same, the absorbent quality used should be progressively reduced.

▼B

**Figure 1**  
*Chromatogram of a sample of soya oil*

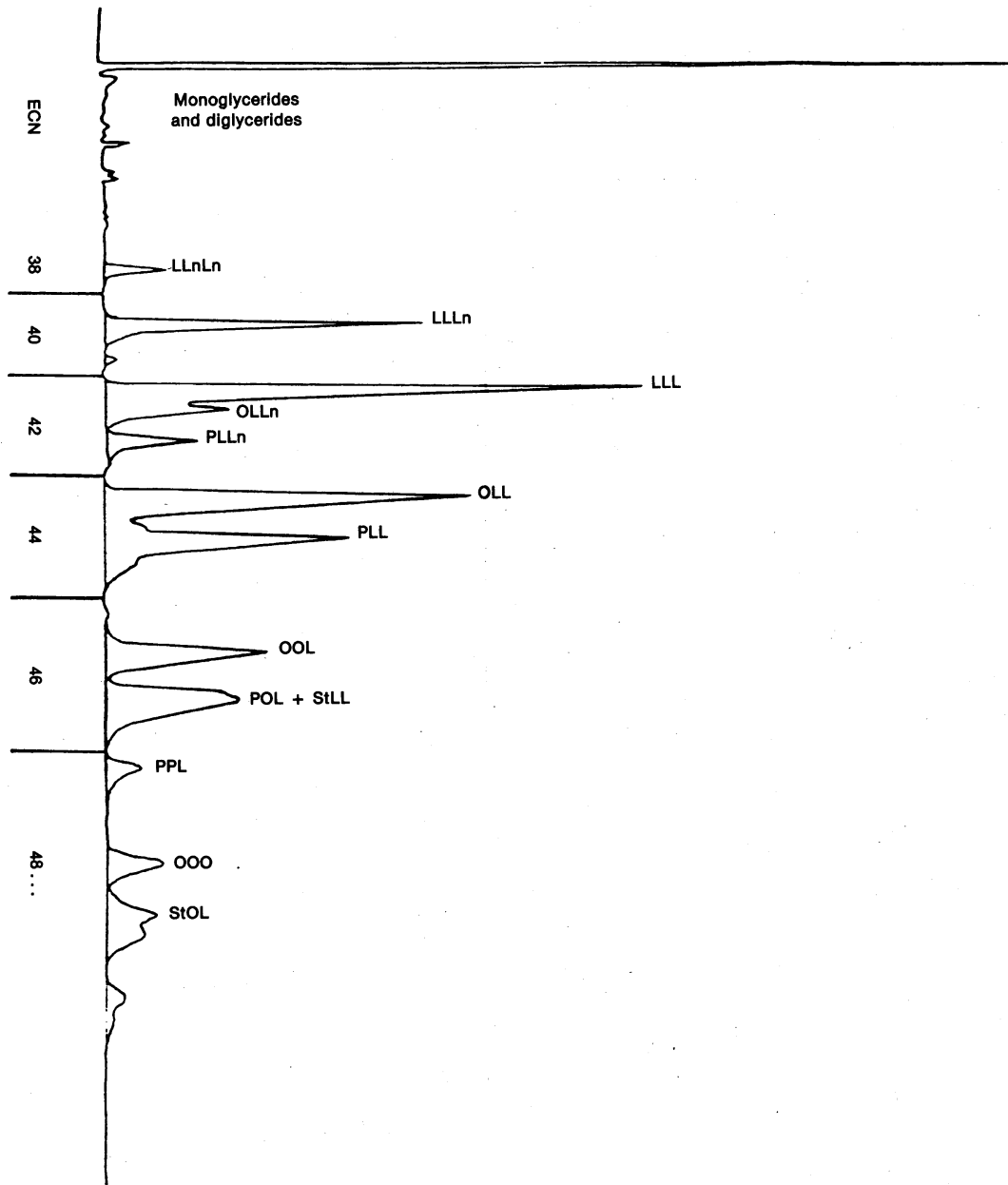

P = palmitic acid  
 L = linoleic acid  
 St = stearic acid  
 ln = linolenic acid  
 O = oleic acid

▼B

Figure 2

Graph of  $\log a$  against  $f$  (number of double bonds)

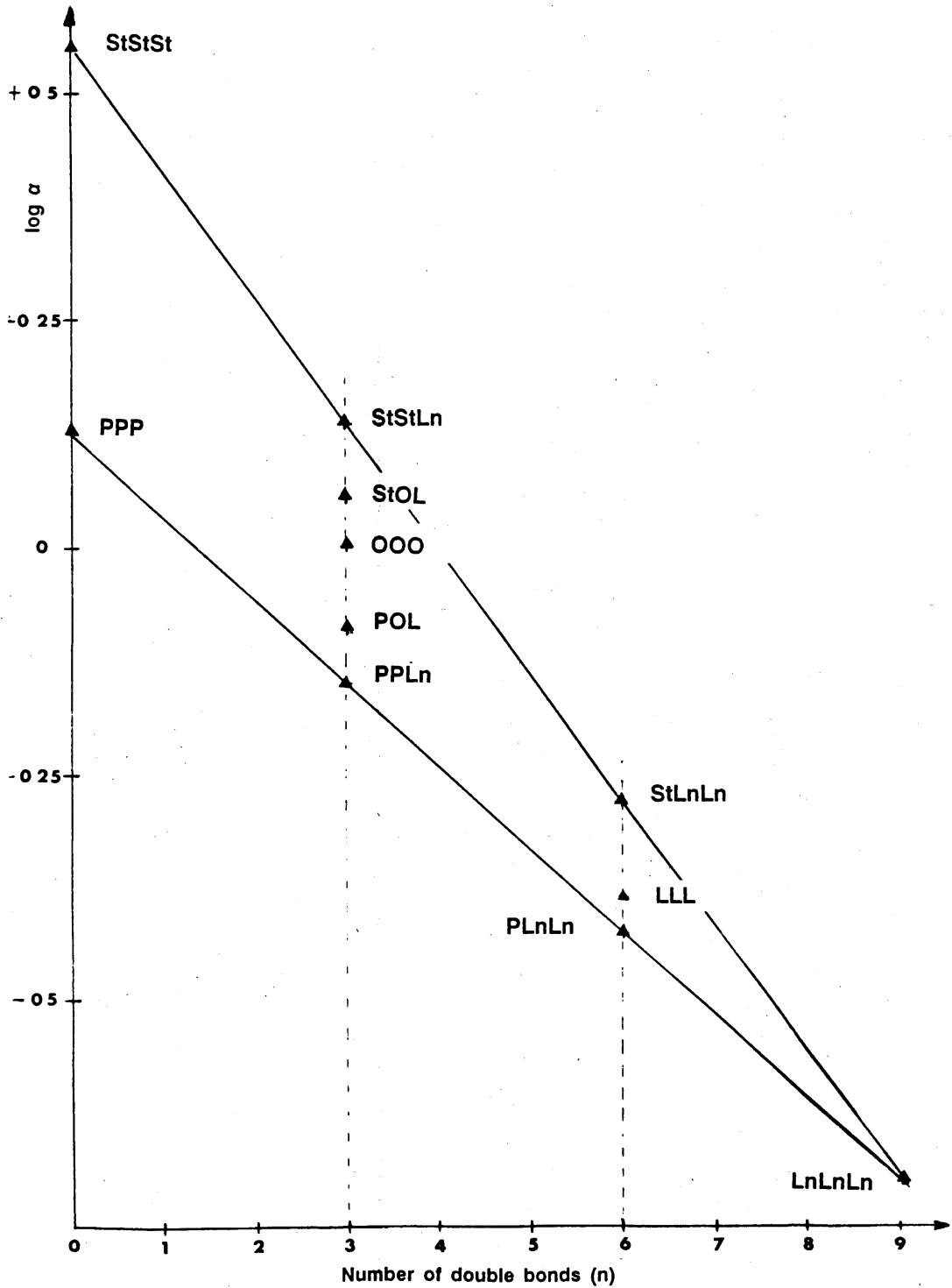

- La = lauric acid
- St = stearic acid
- Ln = linoleic acid
- My = myristic acid
- O = oleic acid
- P = palmitic acid
- L = linoleic acid

**▼B**

## ANNEX IX

**SPECTROPHOTOMETRIC INVESTIGATION IN THE ULTRAVIOLET**

## FOREWORD

Spectrophotometric examination in the ultraviolet can provide information on the quality of a fat, its state of preservation and changes brought about in it by technological processes.

The absorption at the wavelengths specified in the method is due to the presence of conjugated diene and triene systems. These absorptions are expressed as specific extinctions  $E^{1\%}_{1\text{cm}}$  (the extinction of 1 % solution of the fat in the specified solvent, in a thickness of 1 cm) conventionally indicated by K (also referred to as 'extinction coefficient').

## 1. SCOPE

The method describes the procedure for performing a spectrophotometric examination ► **C1** of olive oil in ◀ the ultraviolet.

## 2. PRINCIPLE OF THE METHOD

The fat in question is dissolved in the required solvent and the extinction of the solution is then determined at the specified wavelengths with reference to pure solvent. Specific extinctions are calculated from the spectrophotometer readings.

## 3. EQUIPMENT

- 3.1. A spectrophotometer for measuring extinction in the ultraviolet between 220 and 360 nm, with the possibility of reading individual nanometric units.
- 3.2. Rectangular quartz cuvettes, with covers, having an optical length of 1 cm. When filled with water or other suitable solvent the cuvettes should not show differences between them of more than 0,01 extinction units.
- 3.3. 25 ml graduated flasks.

**▼M6**

- 3.4. Chromatography column having an upper part 270 mm in length and a diameter of 35 mm and a lower part 270 mm in length and a diameter of approximately 10mm.

**▼B**

## 4. REAGENTS

- 4.1. Spectrophotometrically pure iso-octane (2,2,4-trimethylpentane). With reference to distilled water this should have a transmittance of not less than 60 % at 220 nm and not less than 95 % at 250 nm, or
  - spectrophotometrically pure cyclohexane: with reference to distilled water this should have a transmittance of not less than 40 % at 220 nm and not less than 95 % at 250 nm.

**▼M6****▼B**

- 4.2. Basic alumina for column chromatography prepared and checked as described in Appendix I.
- 4.3. n-hexane, for chromatography.

## 5. PROCEDURE

- 5.1. The sample in question must be perfectly homogeneous and without suspected impurities. Oils which are liquid at ambient temperature are to be filtered through paper at a temperature of approximately 30 °C, hard fats are to be homogenized and filtered at a temperature of not more than 10 °C above the melting point.
- 5.2. Weigh accurately approximately 0,25 g of the sample so prepared into a 25 ml graduated flask, make up to the mark with the solvent specified and homogenize. The resulting solution must be perfectly clear. If opalescence or turbidity is present filter quickly through paper.

**▼B**

- 5.3. Fill a cuvette with the solution obtained and measure the extinctions at an appropriate wavelength between 232 and 276 nm, using the solvent used as a reference.

The extinction values recorded must lie within the range 0,1 to 0,8. If not the measurements must be repeated using more concentrated or more dilute solutions as appropriate.

- 5.4. When a determination of specific extinction is required after passage over alumina, proceed as follows. Place 30 g of basic alumina in suspension in hexane in the chromatography column. After the adsorbent has settled remove the excess hexane down to approximately 1 cm above the top of the alumina.

Dissolve 10 g of the fat, homogenized and filtered as described in 5.1, in 100 ml of hexane and pour the solution into the column. Collect the eluate and evaporate off all the solvent under vacuum at a temperature below 25 °C.

Proceed immediately as specified in 5.2 using the fat so obtained.

## 6. EXPRESSION OF THE RESULTS

- 6.1. Record the specific extinctions (extinction coefficients) at the various wavelengths calculated as follows:

$$K_{\lambda} = \frac{E_{\lambda}}{c \cdot s}$$

where:

$K_{\lambda}$  = specific extinction at wavelength  $\lambda$ ;

$E_{\lambda}$  = extinction measured at wavelength  $\lambda$ ;

$c$  = concentration of the solution in g/100 ml;

$s$  = thickness of the cuvette in cm.

The results are to be expressed to two decimal places.

- 6.2. Spectrophotometric analysis of olive oil in accordance with the official method in the EEC regulations specifies determination of the specific extinction in iso-octane solution at wavelengths of 232 and 270 nm and the determination  $K$ , which is given by:

$$\Delta K = K_m - \frac{K_{m-4} + K_{m+4}}{2}$$

where  $K_m$  is the specific extinction at wavelength  $m$ , the wavelength for maximum absorption around 270 nm.

**▼B***APPENDIX I**Preparation of the alumina and testing its activity*

## A.1.1. Preparation of the alumina

Place alumina which has been previously desiccated in a furnace at 380 to 400 °C for three hours into a hermetically sealed container, add distilled water in the ratio of 5 ml per 100 g of alumina, immediately close the container, shake repeatedly, and then allow to rest for at least 12 hours before use.

## A.1.2. Checking the activity of the alumina

Prepare a chromatographic column with 30 g of alumina. Working as described in paragraph 5.4 pass a mixture consisting of:

- 95 % virgin olive oil having a specific extinction of less than 0,18 at 268 nm,
- 5 % ground-nut oil treated with earth in the refining process, having a specific extinction of not less than 4 at 268 nm

through the column.

If after passage through the column the mixture has a specific extinction of more than 0,11 at 268 nm the alumina is acceptable, if not the level of dehydration must be increased.



**▼B***APPENDIX II**Calibration of the spectrophotometer*

- A.2. The equipment must be checked at intervals (at least every six months) for both wavelength response and the accuracy of the response.
- A.2.1. The wavelength may be checked using a mercury vapour lamp or by means of suitable filters.
- A.2.2. In order to check the response of the photocell and the photomultiplier proceed as follows: weigh 0,2000 g of pure potassium chromate for spectrophotometry and dissolve in 0,05 N potassium hydroxide solution in a 1 000 ml graduated flask and make up to the mark. Take precisely 25 ml of the solution obtained, transfer to a 500 ml graduated flask and dilute up to the mark using the same potassium hydroxide solution.

Measure the extinction of the solution so obtained at 275 nm, using the potassium hydroxide solution as a reference. The extinction measured using a 1 cm cuvette should be  $0,200 \pm 0,005$ .

▼**B**

## ANNEX X A

**ANALYSIS BY GAS CHROMATOGRAPHY OF METHYL ESTERS OF FATTY ACIDS**

## 1. SCOPE

This method gives general guidance for the application of gas chromatography, using packed or capillary columns, to determine the qualitative and quantitative composition of a mixture of fatty acid methyl esters obtained in accordance with the method specified in Annex X B.

The method is not applicable to polymerized fatty acids.

## 2. REAGENTS

2.1. **Carrier gas**

Inert gas (nitrogen, helium, argon, hydrogen, etc.), thoroughly dried and with an oxygen content of less than 10 mg/kg.

*Note 1.* Hydrogen, which is used as a carrier gas only with capillary columns, can double the speed of analysis but is hazardous. Safety devices are available.

2.2. **Auxiliary gases**

2.2.1. Hydrogen (purity  $\geq 99,9\%$ ), free from organic impurities.

2.2.2. Air or oxygen, free from organic impurities.

2.3. **Reference standard**

A mixture of methyl esters of pure fatty acids, or the methyl esters of a fat of known composition, preferably similar to that of the fatty matter to be analyzed.

Care shall be taken to prevent the oxidation of polyunsaturated fatty acids.

## 3. APPARATUS

The instructions given relate to the usual equipment used for gas chromatography, employing packed and/or capillary columns and a flame-ionization detector. Any apparatus giving the efficiency and resolution specified in 4.1.2 is suitable.

3.1. **Gas chromatograph**

The gas chromatograph shall comprise the following elements.

## 3.1.1. Injection system

Use an injection system either:

(a) with packed columns, having the least deadspace possible (in this case the injection system shall be capable of being heated to a temperature 20 to 50 °C higher than that of the column); or

(b) with capillary columns, in which case the injection system shall be specially designed for use with such columns. It may be of the split type or it may be of the splitless or column injector type.

*Note 2.* In the absence of fatty acids with less than 16 carbon atoms, a moving needle injector may be used.

## 3.1.2. Oven

The oven shall be capable of heating the column to a temperature of at least 260 °C and of maintaining the desired temperature to within 1 °C with a packed column and within 0,1 °C with a capillary column. The last requirement is particularly important when a fused silica tube is used.

The use of temperature-programmed heating is recommended in all cases, and in particular for fatty acids with less than 16 carbon atoms.

**▼B**

## 3.1.3. Packed column

3.1.3.1. Column, constructed of a material inert to the substances to be analyzed (i.e. glass or stainless steel) having the following dimensions:

- (a) length: 1 to 3 m. A relatively short column should be used when long-chain fatty acids (above C<sub>20</sub>) are present. When analyzing acids with 4 or 6 carbon atoms, it is recommended that a column 2 m in length is used;
- (b) internal diameter: 2 to 4 mm.

*Note 3.* If polyunsaturated components with more than three double bonds are present, they may be decomposed in a stainless steel column.

*Note 4.* A system with packed twin columns may be used.

3.1.3.2. Packing, comprising the following elements:

- (a) *support*: acid-washed and silanized diatomaceous earth, or other suitable inert support with a narrow range of grain size (25 µm range between the limits 125 to 200 µm) the average grain size being related to the internal diameter and length of the column;
- (b) *stationary phase*: polyester type of polar liquid (e.g. diethylene glycol polysuccinate, butanediol polysuccinate, ethyleneglycol polyadipate, etc.) cyanosilicones or any other liquid permitting the chromatographic separation required (see clause 4). The stationary phase should amount to 5 to 20 % (m/m) of the packing. A non-polar stationary phase can be used for certain separations.

3.1.3.3. Conditioning of the column

With the column disconnected, if possible, from the detector, gradually heat the oven to 185 °C and pass a current of inert gas through the freshly prepared column at a rate of 20 to 60 ml/min for at least 16 hours at this temperature, and for a further 2 hours at 195 °C.

## 3.1.4. Capillary column

3.1.4.1. Tube, made of a material inert to the substances to be analysed (usually glass or fused silica). The internal diameter shall be between 0,2 and 0,8 mm. The internal surface shall undergo an appropriate treatment (e.g. surface preparation, inactivation) before receiving the stationary phase coating. A length of 25 mm is sufficient in most cases.

3.1.4.2. Stationary phase, usually of the type polyglycol (poly(ethylene glycol) 20 000), polyester (butanediol polysuccinate) or polar polysiloxane (cyanosilicones). Bonded (cross-linked) columns are suitable.

*Note 5.* There is a risk of polar polysiloxanes giving rise to difficulties in the identification and separation of linolenic acid and C<sub>20</sub> acids.

The coatings shall be thin, i.e. 0,1 to 0,2 µm.

3.1.4.3. Assembly and conditioning of the column

Observe the normal precautions for assembling capillary columns, i.e. arrangement of the column in the oven (support), choice and assembly of joints (leak tightness), positioning of the ends of the column in the injector and the detector (reduction of dead-spaces). Place the column under a flow of carrier gas (e.g. 0,3 bar (30 kPa) for a column of length 25 mm and internal diameter 0,3 mm).

Condition the column by temperature programming of the oven at 3 °C/min from ambient temperature to a temperature 10 °C below the decompose limit of the stationary phase. Maintain the oven at this temperature for one hour until stabilization of the baseline. Return it to 180 °C to work under isothermal conditions.

*Note 6.* Suitably pre-conditioned columns are available commercially.

3.1.5. Detector, preferably capable of being heated to a temperature above that of the column.

## 3.2. Syringe

The syringe shall have a maximum capacity of 10 µl, and be graduated in 0,1 µl divisions.

**▼B****3.3. Recorder**

If the recorder curve is to be used to calculate the composition of the mixture analysed, an electronic recorder of high precision, compatible with the apparatus used, is required. The recorder shall have the following characteristics:

- (a) rate of response, below 1,5 s, preferably 1 s (the rate of response is the time taken for the recording pen to pass from 0 to 90 % following the sudden introduction of a 100 % signal);
- (b) width of the paper, 20 cm minimum;
- (c) paper speed, adjustable to values between 0,4 and 2,5 cm/min.

**3.4. Integrator**

Rapid and accurate calculation can be performed with the help of an electronic integrator. This shall give a linear response with adequate sensitivity, and the correction for deviation of the base-line shall be satisfactory.

**4. PROCEDURE**

The operations described in 4.1 to 4.3 relate to the use of a flame-ionization detector.

As an alternative a gas chromatograph employing a catharometer detector (working on the principle of thermal conductivity changes) may be used. The operating conditions are then modified as described in clause 6.

**4.1. Test conditions****4.1.1. Selection of optimum operating conditions****4.1.1.1. Packed column**

In the selection of the test conditions, the following variables should be taken into account:

- (a) the length and diameter of the column;
- (b) the nature and amount of the stationary phase;
- (c) the temperature of the column;
- (d) the carrier gas flow;
- (e) the resolution required;
- (f) the size of the test portion, selected in such a way that the assembly of the detector and electrometer gives a linear response;
- (g) the duration of analysis.

In general, the values given in Table 1 and Table 2 will lead to the desired results, i.e. at least 2 000 theoretical plates per metre of column length for methyl stearate and its elution within about 15 minutes.

Where the apparatus allows it, the injector should be at a temperature of about 200 °C and the detector at a temperature equal to or higher than that of the column.

As a rule, the ratio of the flow-rate of the hydrogen supplied to the flame-ionization detector to that of the carrier gas varies from 1:2 to 1:1 depending on the diameter of the column. The flow of oxygen is about 5 to 10 times that of the hydrogen.

*Table 1*

Internal diameter of column mm	Carrier gas flow ml/min
2	15 to 25
3	20 to 40
4	40 to 60

▼ B

Table 2

Concentration of stationary phase % (m/m)	Column temperature °C
5	175
10	180
15	185
20	185

## 4.1.1.2. Capillary column

The properties of efficiency and permeability of capillary columns mean that the separation between constituents and the duration of the analysis are largely dependent on the flow-rate of the carrier-gas in the column. It will therefore be necessary to optimize the operating conditions by acting on this parameter (or more simply on the headloss of the column), according to whether one wishes to improve the separations or to make a rapid analysis.

## 4.1.2. Determination of the number of theoretical plates (efficiency) and resolution (See Figure 1)

Carry out the analysis of a mixture of methyl stearate and methyl oleate in about equivalent proportions (for example, methyl esters from cocoa butter).

Choose the temperature of the column and the carrier gas flow so that the maximum of the methyl stearate peak is recorded about 15 minutes after the solvent peak. Use a sufficient quantity of the mixture of methyl esters that the methyl stearate peak occupies about three-quarters of the full scale.

Calculate the number of theoretical plates,  $n$  (efficiency), using the formula:

$$n = 16 \left[ \frac{dr_1}{\omega_1} \right]^2$$

and the resolution,  $R$ , using the formula:

$$R = \frac{2\Delta}{\omega_1 + \omega_2}$$

where:

$dr_1$  is the retention distance, in millimetres, from the start of the chromatogram to the maximum of the peak for methyl stearate;

$\omega_1$  and  $\omega_2$  are the widths, in millimetres, of the peaks for methyl stearate and methyl oleate respectively, measured between the points of intersection of the tangents at the points of inflection of the curve with the base-line;

$\Delta$  is the distance, in millimetres, between the peak maxima for methyl stearate and methyl oleate;

▼ M2

and the resolution index,  $lr$ , using the formula

$$\frac{a}{b}$$

where:

$a$  = the height of the smallest peak, measured from the base line;

$b$  = the height of the lowest point of the valley between the two adjacent peaks, measured from the base line.

▼B

Figure 1

Chromatogram for determining the number of theoretical plates (efficiency) and resolution

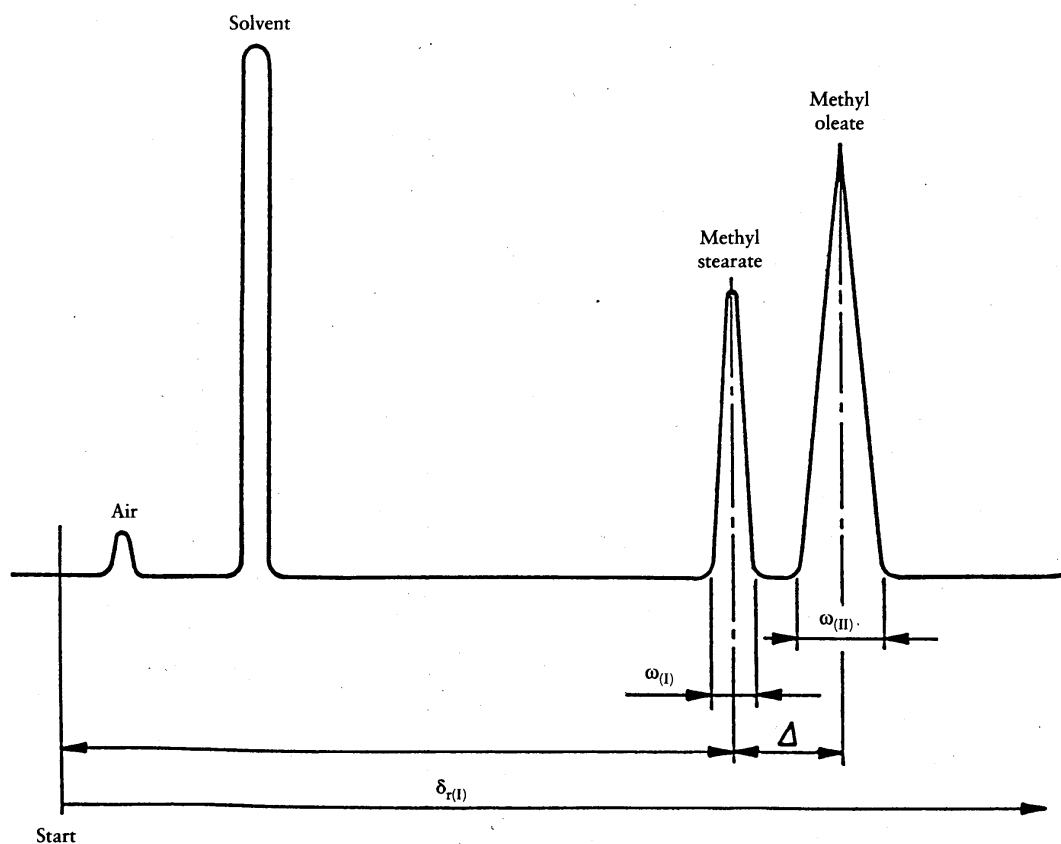

The operating conditions to be selected are those which will afford at least 2 000 theoretical plates per metre of column length for methyl stearate and a resolution of at least 1,25.

#### 4.2. Test portion

Using the syringe (3.2) take 0,1 to 2  $\mu$ l of the solution of methyl esters prepared according to Annex X B and inject them into the column.

In the case of esters not in solution, prepare a solution of approximately 100 mg/ml in heptane of chromatographic quality, and inject 0,1 to 1 ml of this solution.

If the analysis is for constituents present only in trace amounts, the size of the test portion may be increased (up to 10-fold).

#### 4.3. Analysis

Generally, the operating conditions shall be those defined in 4.1.1.

Nevertheless, it is possible to work with a lower column temperature when the determination of fatty acids with fewer than 12 carbon atoms is required, or at a higher temperature when determining fatty acids with more than 20 carbon atoms. On occasion, it is possible to employ temperature programming in both these cases. For example, if the sample contains the methyl esters of fatty acids with fewer than 12 carbon atoms, inject the sample at 100 °C (or at 50 to 60 °C if butyric acid is present) and immediately raise the temperature at a rate of 4 to 8 °C/min to the optimum. In certain cases, the two procedures can be combined.

After the programmed heating, continue the elution at a constant temperature until all the components have been eluted. If the instrument does not have programmed heating, use it at two fixed temperatures between 100 and 195 °C.

**▼B**

If necessary, it is recommended that an analysis be carried out on two fixed phases with different polarities to verify the absence of masked peaks, for example in the case of the simultaneous presence of C<sub>18:3</sub> and C<sub>20:0</sub>, or C<sub>18:3</sub> and C<sub>18:2</sub> conjugated.

#### 4.4. Preparation of the reference chromatogram and reference graphs

Analyze the reference standard mixture (2.3) using the same operating conditions as those employed for the sample, and measure the retention times or retention distances for the constituent fatty acids. Construct on semi-logarithmic paper, for any degree of unsaturation, the graphs showing the logarithm of retention time or distance as a function of the number of carbon atoms. In isothermal conditions, the graphs for straight-chain acids of the same degree of unsaturation should be straight lines. These lines should be approximately parallel.

It is necessary to avoid conditions such that 'masked peaks' exist, i.e. where the resolution is insufficient to separate two constituents.

### 5. EXPRESSION OF RESULTS

#### 5.1. Qualitative analysis

Identify the methyl ester peaks for the sample from the graphs prepared in 4.4, if necessary by interpolation.

#### 5.2. Quantitative analysis

##### 5.2.1. Determination of the composition

Apart from exceptional cases, use the internal normalization method, i.e. assume that the whole of the components of the sample are represented on the chromatogram, so that the total of the areas under the peaks represents 100 % of the constituents (total elution).

If the equipment includes an integrator, use the figures obtained therefrom. If not, determine the area under each peak by multiplying the height of the peak by its width at mid-height, and where necessary take into account the various attenuations used during the recording.

##### 5.2.2. Method of calculation

###### 5.2.2.1. General case

Calculate the content of a given component *i*, expressed as a percentage by mass of methyl esters, by determining the percentage represented by the area of the corresponding peak relative to the sum of the areas of all the peaks, using the following formula:

$$\frac{A_i}{\Sigma A} \times 100$$

where:

*A<sub>i</sub>* is the area under the peak corresponding to component *i*;

$\Sigma A$  is the sum of the areas under all the peaks.

Give the result to one decimal place.

*Note 7:* In this general case, the result of the calculation based on relative areas is considered to represent a percentage by mass. For the cases in which this assumption is not allowed, see 5.2.2.2.

###### 5.2.2.2. Use of correction factors

In certain cases, for example in the presence of fatty acids with fewer than eight carbon atoms or of acids with secondary groups, when using thermal conductivity detectors or where the highest degree of accuracy is particularly required, correction factors should be used to convert the percentages of peak areas into mass percentages of the components.

Determine the correction factors with the help of a chromatogram derived from the analysis of a reference mixture of methyl esters of known composition, carried out under operating conditions identical with those used for the sample.

For this reference mixture, the percentage by mass of component *i* is given by the formula:

**▼B**

$$\frac{m_i}{\Sigma m} \times 100$$

where:

$m_i$  is the mass of component  $i$  in the reference mixture;

$\Sigma m$  is the total of the masses of the various components of the reference mixture.

From the chromatogram of the reference mixture (4.4) calculate the percentage (area/area) for component  $i$  as follows:

$$\frac{A_i}{\Sigma A} \times 100$$

where:

$A_i$  is the area under the peak corresponding to component  $i$ ;

$\Sigma A$  is the sum of the areas under all the peaks.

The correction factor is then calculated as:

$$K_i = \frac{m_i \times \Sigma A}{A_i \times \Sigma m}$$

Commonly, the correction factors are expressed relative to  $K_{C_{16}}$ , so that the relative factors become:

$$K'_i = \frac{K_i}{K_{C_{16}}}$$

For the sample, the content of each component  $i$ , expressed as a percentage by mass of methyl esters, is:

$$\frac{K'_i \times A_i}{\Sigma (K'_i \times A_i)} \times 100$$

Give the results to one decimal place.

## 5.2.2.3. Use of an internal standard

In certain analyses (for example where not all of the fatty acids are quantified, such as when acids with four and six carbons are present alongside acids with 16 and 18 carbons, or when it is necessary to determine the absolute amount of a fatty acid in a sample) it is necessary to use an Internal Standard. Fatty acids with five, 15 or 17 carbons are frequently used. The correction factor (if any) for the Internal Standard should be determined.

The percentage by mass of component  $i$ , expressed as methyl esters, is then given by the formula:

$$\frac{m_s \times K'_i \times A_i}{m \times K'_s \times A_s} \times 100$$

where:

$A_i$  is the area under the peak corresponding to component  $i$ ;

$A_s$  is the area under the peak corresponding to the Internal Standard;

$K'_i$  is the correction factor for component  $i$  (relative to  $K_{C_{11}}$ );

$K'_s$  is the correction factor for the Internal Standard (relative to  $K_{C_{16}}$ );

$m$  is the mass, in milligrams, of the test portion;

$m_s$  is the mass, in milligrams, of the Internal Standard.

Give the results to one decimal place.

**▼M2**

## 6. SPECIAL CASE — DETERMINATION OF TRANS-ISOMERS

It is possible to determine the content of trans-isomers in fatty acids with a number of carbon atoms between 10 and 24 by separating the methyl esters using gas chromatography capillary columns having a specific polarity.



## ▼ M2

- 6.1. A capillary column made of silica having an internal diameter of between 0,25 mm and 0,32 mm and a length of 50 m, coated with cyanopropylsilicon, the thickness of the coating being between 0,1 and 0,3  $\mu\text{m}$  (type SP 2380, C.P. sil 88, silor 10 and similar types).
- 6.2. The methyl esters are prepared using the procedure set out in Annex X B. As a precaution, fatty substances having a free acidity over 3 % must be neutralized in accordance with 6.1 of Annex VII.
- 6.3. The operating conditions for gas chromatography are overall as follows:
  - column temperature set between 150 °C and 230 °C (for example 165 °C for 15 minutes then increasing by 5 °C a minute to 200 °C);
  - injector temperature: 250 °C if the splitting system is used or the initial temperature of the column if the on-column system is used;
  - detector temperature: 260 °C;
  - flow rate of the carrier gas (helium and hydrogen): 1,2 ml a minute.
 The quantity injected must be such that in the conditions of sensitivity employed the height of the peak corresponding to the methyl ester of the arachidic acid is equal to or greater than 20 % of the bottom of the scale.
- 6.4. Identification of the various methyl esters is effected on the basis of the retention times which are compared with those for the reference mixtures (as indicated at point 2.3).

The esters of trans fatty acids are eluted before the corresponding cis-isomers. An example of a chromatogram is given in figure 2.

**Figure 2:**

Gas chromatogram of the trans-isomers of fatty acid using capillary column.

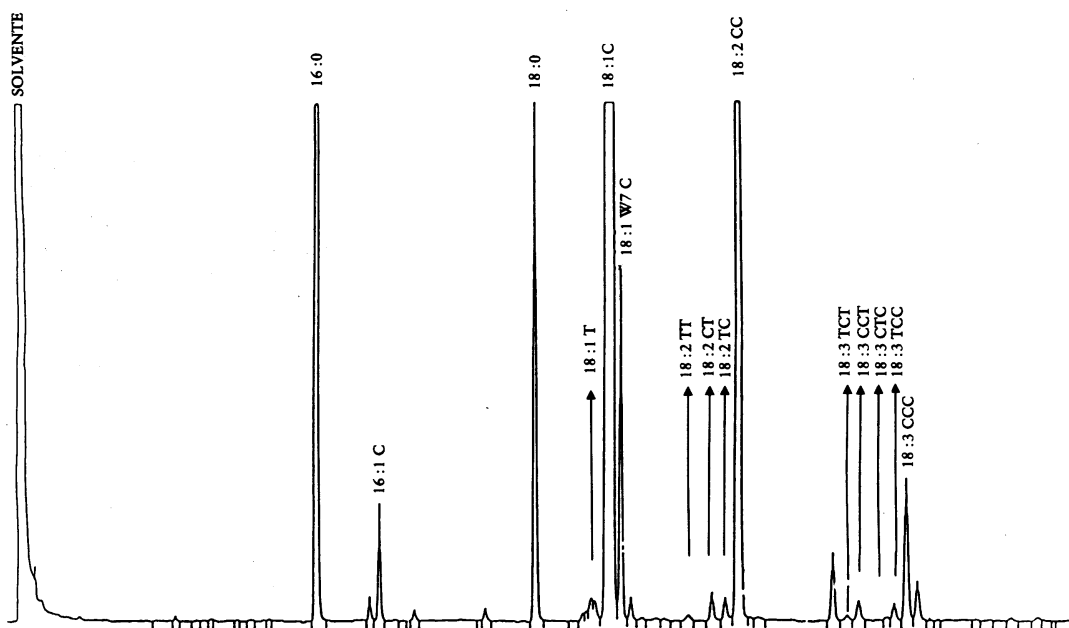

- 6.5. The efficiency of the column determined in accordance with point 4.1.2 must be such as to allow separation of certain critical couples, for example the couple formed by the massif of the transoleic acids and the oleic acid peak, trans C18:1/cis C18:1, with a resolution index greater than 2.
- 6.6. The percentage of the various trans fatty acids is calculated on the basis of the relationship between the surface of the relevant peak and the sum of the surfaces of all the peaks present.

The percentages of:

- the trans octadecenoic acids (T 18: 1) indicated in Annex I to this Regulation as the sum of the transoleic isomers;
- the cis-trans and trans-cis octadecadienoic acids [(CT/TC) 18: 2] indicated in Annex I to this Regulation as the sum of the translinoleic isomers;

**▼ M2**

— the trans-cis-trans, cis-cis-trans, cis-trans-cis, trans-cis-cis, octadeca-trienoic acids [(TCT + CCT + CTC + TCC) 18: 3], indicated in Annex I of this Regulation as the sum of the translinolenic isomers are taken into account.

*Note 8:* Taking into account the particular characteristics of this method, please give the results with 2 decimals.

**▼ B**

**► M2 7. ◀ SPECIAL CASE — USE OF A CATHAROMETER DETECTOR (WORKING ON THE PRINCIPLE OF THERMAL CONDUCTIVITY CHANGES)**

A gas chromatograph employing a detector working on the principle of thermal conductivity changes (a catharometer) may also be used for the determination of the qualitative and quantitative composition of a mixture of fatty acid methyl esters. If it is used, the conditions specified in clause 3 and clause 4 should be modified as shown in Table 3.

For quantitative analysis, use the correction factors defined in 5.2.2.2.

*Table 3*

Variable	Value/condition
Column	Length: 2 to 4 m Internal diameter: 4 mm
Support	Grain size between 160 and 200 µm
Concentration of stationary phase	15 to 25 % (m/m)
Carrier gas	Helium or, failing this, hydrogen, with as low an oxygen content as possible
Auxiliary gases	None
Injector temperature	From 40 to 60 °C above that of the column
Column temperature	180 to 200 °C
Flow of carrier gas	Usually between 60 and 80 ml/min
Size of test portion injected	Usually between 0,5 and 2 µl

**► M2 8. ◀ TEST REPORT**

The test report shall specify the methods used for the preparation of the methyl esters and for the gas chromatographic analysis, and the results obtained. It shall also mention all operating details not specified in this International Standard, or regarded as optional, together with details of any incidents which may have influenced the results.

The test report shall include all information necessary for the complete identification of the sample.



## ANNEX X B

**PREPARATION OF METHYL ESTERS OF FATTY ACIDS IN ACCORDANCE WITH TITLES I AND II OF ANNEX VI TO REGULATION (EEC) No 72/77 OR THE METHOD DESCRIBED BELOW**

## FOREWORD

The choice of process will be dictated by the acid composition and acidity of the fatty substance under examination and the gas chromatography analysis to be carried out.

More specifically:

- only sealed phial processes or processes using dimethyl sulphate can be used for fatty substances containing fatty acids with fewer than 12 carbon atoms,
- only the methanol-hydrochloric acid or methyl sulphate processes can be used for fatty substances with acidity of over 3 %,
- only processes using sodium methylate or dimethyl sulphate can be used for gas chromatography measurements of trans-Isomers,
- the methanol-hexane-sulphuric acid process must be used for the preparation of the methyl esters of small quantities of fatty substances from separation by thin layer chromatography.

The presence of unsaponifiables can be discounted, provided it does not exceed 3 %, otherwise the methyl esters will have to be prepared from the fatty acids.

## 1. SCOPE AND FIELD OF APPLICATION

A description is given of five processes for the preparation of methyl esters from fatty substances:

- (a) with sodium methylate;
- (b) with sodium methylate in a sealed phial;
- (c) with methanol-hydrochloric acid in a sealed phial;
- (d) with dimethyl sulphate;
- (e) with methanol-hexane-sulphuric acid.

**Process A**

## 2. PRINCIPLE

The fatty substance which is being subjected to analysis is heated under reflux with methyl alcohol and sodium methylate. The methyl esters obtained are extracted with ethyl ether.

## 3. APPARATUS

- 3.1. 100 ml flask with a reflux condenser with a soda lime tube fitted to the top, with ground glass joints.
- 3.2. 50 ml measuring glasses.
- 3.3. 5 ml measuring pipette marked off in 0,1 ml.
- 3.4. 250 ml separating funnels.
- 3.5. 200 ml flask.

## 4. REAGENTS

- 4.1. Anhydrous methanol.
- 4.2. Solution of approximately 1 % sodium methylate in methanol; this is prepared by dissolving 0,34 g of metallic sodium in 100 ml of anhydrous methanol.
- 4.3. Ethyl ether.
- 4.4. 10 % sodium chloride solution.
- 4.5. 40 to 60 °C petroleum ether.

**▼B****5. PROCEDURE**

- 5.1. Place in the 100 ml flask 2 g of the fatty substance which has previously been dried out on sodium sulphate and filtered. Add 35 ml of methanol, fit the condenser and boil under reflux a few minutes.
- 5.2. Stop the heating process, remove the condenser and add rapidly 3,5 ml of sodium methylate solution; refit the condenser and boil under reflux for at least 3 hours. Methylation is complete when all the fatty substance has liquified and the reagent mixture is perfectly clear at room temperature.
- 5.3. Cool and pour the reagent mixture into a 250 ml separating funnel, add 35 to 40 ml of ethyl ether, 100 ml of water and 5 to 6 ml of 10 % sodium chloride solution. Shake and allow the layers to separate. Transfer the aqueous phase to a second separating funnel and extract once again with 25 ml of ethyl ether.

Add 50 ml of 40 to 60 °C petroleum ether to the combined ether extracts. Water will be separated and can be eliminated.

Wash the ether phase three times with 10 to 15 ml of water, dry on sodium sulphate and filter through paper, collecting the filtrate in the 200 ml flask.

Evaporate the solvent to 20 ml, completing the process over a water bath in a current of pure nitrogen.

**Process B****2. PRINCIPLE**

The fatty substance which is being subjected to analysis is treated with sodium methylate in a methanol solution, in a sealed phial, at 85 to 90 °C.

**3. APPARATUS**

- 3.1. Strong glass phial with a capacity of approximately 5 ml (height 40 to 45 mm, diameter 14 to 16 mm).
- 3.2. 1 ml measuring pipette marked off in 0,1 ml.

**4. REAGENTS**

- 4.1. Solution of approximately 1,5 % sodium methylate in methanol. This is prepared by dissolving 0,50 g of metallic sodium in 100 ml of anhydrous methanol.

**5. PROCEDURE**

- 5.1. Place in the glass phial 2 g of the fatty substance, which has previously been dried out on sodium sulphate and filtered. Add 0,3 g (approximately 0,4 ml) of sodium methylate solution and heat seal the phial.
- 5.2. Immerse the phial for 2 hours at 85 °C to 90 °C, shaking from time to time. The esterification process is complete when the contents of the phial are clear after sedimentation of the glycerine and the residue of the reagents.
- 5.3. Cool at room temperature. Open the phial when the methyl esters are to be used. These do not require any further treatment before being placed in the gas chromatography apparatus.

**Process C****2. PRINCIPLE**

The fatty substance which is being subjected to analysis is treated with methanol-hydrochloric acid, in a sealed phial, at 100 °C.

**3. APPARATUS**

- 3.1. Strong glass phial with a capacity of approximately 5 ml (height 40 to 45 mm, diameter 14 to 16 mm).
- 3.2. 1 and 2 ml calibrated pipettes.

**4. REAGENTS**

- 4.1. Solution of hydrochloric acid in 2 % methanol. This is prepared from gaseous hydrochloric acid and anhydrous methanol (Note 1).
- 4.2. Hexane for gas chromatography.

**▼B**

## 5. PROCEDURE

- 5.1. Place in the glass phial 0,2 g of the fatty substance, which has previously been dried out on sodium sulphate and filtered, and 2 ml of hydrochloric acid-methanol solution. Heat seal the phial.
- 5.2. Immerse the phial at 100 °C for 40 minutes.
- 5.3. Cool the phial under running water, open, add 2 ml of distilled water and 1 ml of hexane. Centrifuge and remove the hexane phase which is ready for use.

**Process D**

## 2. PRINCIPLE

The fatty substance which is being subjected to analysis is saponified with a methyl alcohol solution of potassium hydroxide, and then treated with dimethyl sulphate. When hydrochloric acid is added, the methyl esters which have formed are automatically separated. Very pure methyl esters are obtained by subsequent treatment with alumina.

## 3. APPARATUS

- 3.1. Strong test tube with a capacity of approximately 20 ml, with 10/19 ground glass stopper and safety clips.
- 3.2. Reflux condensers, with 10/19 ground glass attachment.
- 3.3. Glass filters with sintered disc, G 2 size, 20 mm diameter.
- 3.4. Glass test tubes with a capacity of approximately 10 ml and a conical base.
- 3.5. 1 ml and 5 ml syringes.

## 4. REAGENTS

- 4.1. Potassium hydroxide, 10 % solution in methyl alcohol for gas chromatography.
- 4.2. Green bromocresol indicator: 0,05 % solution in methyl alcohol.
- 4.3. Dimethyl sulphate ( $p = 1,335$  at 15 °C).
- 4.4. Concentrated hydrochloric acid ( $p = 1,19$ ) diluted in equal parts with methyl alcohol for gas chromatography.
- 4.5. Brockmann aluminium oxide for adsorption chromatography.

## 5. PROCEDURE

- 5.1. Place in the 20 ml test-tube 2,2 ml of the fatty substance, which has previously been dried out on sodium sulphate and filtered. Add 5 ml of the potassium hydroxide solution and a few quartz granules to control boiling. Attach the reflux condenser and heat over a low flame for five minutes, shaking. Saponification will be complete when the solution is clear. Finally, cool with running water and remove the condenser.
- 5.2. Add two drops of the indicator and, using a syringe, 1 ml of dimethyl sulphate, slowly. Seal the test tube hermetically and shake for two to three minutes, immersing the bottom of the test tube in a boiling water bath at frequent intervals. The reaction is complete when the indicator changes from blue to yellow. Finally, cool the test tube under running water, then open and add 5 ml of the hydrochloric acid methanol solution.
- 5.3. After shaking for a few seconds, lay the test tube at an angle and then tap it lightly. This will help the methyl esters to rise to the surface in the form of an oily mass (Note A).

Remove the methyl esters with a syringe, place in a test tube with a conical base, add a volume of alumina equal to approximately  $\frac{1}{4}$  of the volume of the methyl esters, shake and filter with filter paper.

*Note A.* If the methyl esters do not separate spontaneously, add 5 ml of water to the test tube and shake.

**▼B****Process E****2. PRINCIPLE**

The fatty substance which is being subjected to analysis is heated under reflux with methanol-hexane-sulphuric acid. The methyl esters obtained are extracted with petroleum ether.

**3. APPARATUS**

- 3.1. Test tube of a capacity of approximately 20 ml, fitted with an air reflux condenser approximately 1 m in length, with ground glass joints.
- 3.2. 5 ml calibrated pipette.
- 3.3. 50 ml separating funnel.
- 3.4. 10 ml and 25 ml measuring glasses.
- 3.5. 15 ml test tube with conical base.

**4. REAGENTS**

- 4.1. Methylation reagent: anhydrous methanol-hexane-concentrated sulphuric acid ( $p = 1,84$ ) in the ratio 75:25:1 (V/V/V).
- 4.2. 40 to 60 °C petroleum ether.
- 4.3. Anhydrous sodium sulphate.

**5. PROCEDURE**

- 5.1. Place the matter taken from the plate in the 20 ml test tube and add 5 ml of methylation reagent.
- 5.2. Fit the reflux condenser and heat for 30 minutes in a boiling water bath (Note 2).
- 5.3. Transfer quantitatively the mixture into a 50 ml separating funnel, with the aid of 10 ml distilled water and 10 ml petroleum ether. Shake vigorously, and allow the phases to separate, remove the aqueous phase and wash the ether layer twice with 20 ml distilled water. Add to the separating funnel a small quantity of anhydrous sodium sulphate, shake, allow to settle for a few minutes and filter, collecting the filtrate in a 15 ml test tube with a conical base.

Evaporate the solvent over a water bath in a current of nitrogen.

*Note 1.* Small amounts of gaseous hydrochloric acid can easily be prepared in the laboratory by simple displacement from the commercial solution ( $p = 1,18$ ) by dripping concentrated sulphuric acid ( $p = 1,84$ ). The liberated gas is easily dried by bubbling through conc. sulphuric acid. Since hydrochloric acid is very rapidly absorbed by methanol, it is advisable to take the usual precautions in dissolving it, e.g. introduce the gas through a small inverted funnel with the rim just touching the surface of the liquid. Large quantities of methanolic hydrochloric acid solution can be prepared in advance, as it keeps perfectly in glass-stoppered bottles stored in the dark.

*Note 2.* To control the boiling point insert a glass rod into the test tube and limit the temperature of the water bath to 90 °C.



## ANNEX XI

**DETERMINATION OF VOLATILE HALOGENATED SOLVENTS  
CONTENT OF OLIVE OIL**

## 1. METHOD

Analysis by gas chromatography using the head space technique.

## 2. EQUIPMENT

- 2.1. Gas chromatography apparatus fitted with an electron capture detector (ECD).
- 2.2. Head space apparatus.
- 2.3. Gas chromatography column, of glass, 2 m long and 2 mm in diameter, stationary phase. OV101 10 % or equivalent, impregnating a calcined diatomaceous earth, acid washed and silanised and of a particle size of 80 to 100 mesh.
- 2.4. Carrier and auxiliary gas: nitrogen for gas chromatography, suitable for detection by electron capture.
- 2.5. Glass flasks, 10 to 15 ml, with teflon coating and aluminium stopper with fitment for entry of syringe.
- 2.6. Hermetically sealing clamps.
- 2.7. Gas syringe 0,5 to 2 ml.

## 3. REAGENTS

Standard: halogenated solvents of a degree of purity suitable for gas chromatography.

## 4. PROCEDURE

- 4.1. Exactly weigh around 3 g of oil in a glass flask (not to be reused); hermetically seal it. Place it in a thermostat at 70 °C for one hour. Using a syringe carefully remove 0,2 to 0,5 ml of the head space. Inject this into the column of the gas chromatography apparatus regulated as follows:
  - injector temperature: 150 °C,
  - column temperature: 70 to 80 °C,
  - detector temperature: 200 to 250 °C.Other temperatures may also be used provided the results remain equivalent.
- 4.2. Reference solutions: prepare standard solutions using refined olive oil with no trace of solvents with concentrations ranging from 0,05 to 1 ppm (mg/kg) and corresponding to the presumed content of the sample. The halogenated solvents may be diluted using pentane.
- 4.3. Quantitative assessment: correlate the surfaces or the elevations of the peaks of the sample and of the standard solution of the concentration presumed closest. If the deviation is greater than 10 % the analysis must be repeated in comparison with another standard solution until the deviation is within 10 %. The content is determined on the basis of the average of the elementary injections.
- 4.4. Expression of results: in ppm (mg/kg). The detection limit for the method is 0,01 mg/kg.

**▼B**

## ANNEX XII

**ORGANOLEPTIC ASSESSMENT OF VIRGIN OLIVE OIL**

## 1. SCOPE

The purpose of this method is to determine the criteria needed to assess the flavour characteristics of virgin olive oil and to develop the methodology required to do so.

## 2. FIELD OF APPLICATION

The method described is only applicable to the organoleptic assessment and classification of virgin olive oil that can be used for direct consumption. It confines itself to grading the virgin oil on a numerical scale related to the perception of its flavour stimuli, according to the judgement of a group of selected tasters working as a panel.

## 3. GENERAL BASIC VOCABULARY FOR SENSORY ANALYSIS

See the Chapter entitled 'Sensory analysis: general basic vocabulary'.

**▼M3**

## 4. SPECIFIC VOCABULARY FOR OLIVE OIL

## 4.1. Pleasant sensations, produced by the attributes and characteristics of quality in olive oils:

*Fruity*: flavour which is reminiscent of both the odour and taste of sound, fresh fruit picked as its optimum stage of ripeness.

*Ripely fruity*: flavour of olive oil obtained from ripe fruit, generally having a somewhat flat odour and a sweet taste.

*Green fruity*: flavour of oil obtained from fruit that is still unripe.

## 4.2. Sensations that may be pleasant to varying degrees, depending on the intensity with which they are perceived, and which cannot be considered defects although they do affect the fruity wholeness of the oil:

*Apple*: flavour of olive oil which is reminiscent of this fruit.

*Sweet*: pleasant taste, not exactly sugary, but found in oil in which the bitter, stringent and pungent attributes do not predominate.

*Grass*: characteristic flavour of certain oils reminiscent of recently mown grass.

*Green leaves (bitter)*: flavour of oil obtained from excessively green olives or olives that have been crushed with leaves and twigs.

*Bitter*: characteristic taste of oils obtained from green olives or olives turning colour. It can be more or less pleasant depending on its intensity.

*Harsh*: characteristic sensation of certain oils which when tasted produce a mouthfeel reaction of astringency.

*Pungent*: biting taste sensation characteristic of oils produced at the start of the crop year, primarily from olives that are still unripe. It is caused by the action of phenolic substances on the tips of the trigeminal nerve that are spread over the entire mouth cavity.

*Almond*: this flavour may appear in two forms: that typical of the fresh almond or that peculiar to dried, sound almonds which can be confused with incipient rancidity. A distinctive taste is perceived as an aftertaste when the oil remains in contact with the tongue and the palate. Associated with sweet oils which have a flat odour.

*Flat or smooth*: flavour of olive oil whose organoleptic characteristics are very weak owing to the loss of their aromatic components.

*Hay*: characteristic flavour of certain oils reminiscent of more or less dried grass.

## 4.3. Sensations that are always unpleasant, even when their intensity is barely perceptible, and which have to be considered organoleptic defects:

*Esparto*: characteristic flavour of oil obtained from olives pressed in new esparto mats. The flavour may differ depending on whether the mats are made of green esparto or dried esparto.



▼ **M3**

*Earthy*: characteristic flavour of oil obtained from olives which have been collected with earth or mud on them and not washed. This flavour may sometimes be accompanied by a musty-humid flavour.

*Old*: characteristic flavour of oil that has been kept too long in storage containers. May also appear in oils which have been packed for an excessively long period.

*Grubby*: characteristic flavour of oil obtained from olives which have been heavily attacked by the grubs of the olive fly (*Dacus oleae*).

*Metallic*: flavour that is reminiscent of metal. Characteristic of oils which have been in prolonged contact, under unsuitable conditions, with food-stuffs or metallic surfaces during crushing, mixing, pressing or storage.

*Mustiness-humidity*: characteristic flavour of oils obtained from fruit in which large numbers of fungi and yeasts have developed, as a result of its being stored in piles, in humid conditions, for several days.

*Rancid*: characteristic flavour common to all oils and fats that have undergone a process of auto-oxidation caused by prolonged contact with the air. This flavour is unpleasant and cannot be corrected.

*'Atrojado' (fusty)*: characteristic flavour of oil obtained from olives stored in piles which have undergone an advance stage of fermentation.

*Brine*: flavour of oil extracted from olives which have been preserved in saline solutions.

*Pomace*: characteristic flavour that is reminiscent of the flavour of olive pomace.

*Soapy*: flavour producing an olfactory-gustatory sensation reminiscent of that produced by green soap.

*Vegetable water*: characteristic flavour acquired by the oil as a result of poor decantation and prolonged contact with vegetable water.

*Winey-vinegary*: characteristic flavour of certain oils reminiscent of wine or vinegar. Due mainly to the formation of acetic acid, ethyl acetate and ethanol in larger amounts than is usual in the aroma of olive oil.

*Cucumber*: flavour produced when an oil is hermetically packed for too long, particularly in tin containers, and which is attributed to the formation of 2,6 nonadienal.

*Heated or burnt*: characteristic flavour of oils caused by excessive and/or prolonged heating during processing, particularly when the paste is thermally mixed, if this is done under unsuitable conditions.

*Muddy sediment*: characteristic flavour of oil recovered from the decanted sediment in vats and underground tanks.

*Pressing mat*: characteristic flavour of oil obtained from olives that have been pressed in dirty pressing mats in which fermented residues have been left.

*Greasy*: odour of olive oil extracted in a plant where residues of petroleum, grease or mineral oil have not been properly removed from the machinery.

*Rough*: characteristic perception in certain oils which, when tasted, produce a thick, pasty mouthfeel sensation.

▼ **B**

## 5. GLASS FOR OIL TASTING

See the Chapter entitled 'Glass for oil tasting'.

## 6. TEST ROOM

See the Chapter entitled 'Guide for the installation of a test room'.

## 7. APPARATUS

The following apparatus, which is required by the taster to perform his task properly, shall be supplied in each booth and shall be within easy reach:

- glasses (standardized) containing the samples marked with a legend consisting of two randomly-picked figures or of two figures and letters. The marks shall be made with an indelible, odourless pencil,
- watch-glasses with identical marks, to cover the glasses,

**▼B**

- grading sheet (see Figure 2) containing the instructions for its use,
- pencil or pen,
- small trays of sliced apple,
- glass of water at ambient temperature.

**8. METHODOLOGY**

This section stipulates the prior knowledge required to perform the sensory analysis of virgin olive oils and attempts to standardize the conduct and procedure of the tasters participating in such tests who must be aware of both the general and specific recommendations for olive oil tasting.

**8.1. Duties of the panel organizer or supervisor (or panel)**

The panel organizer shall be a suitably trained, knowledgeable person who is an expert on the kinds of oils which he will come across in the course of his work. He is the key figure in the panel and is responsible for its organization and running. He shall summon the tasters sufficiently in advance and shall clarify any doubts they may have as regards the performance of the tests, but shall refrain from suggesting any opinion to them on the sample.

He shall be responsible for inventorying the apparatus and for ensuring that it is properly cleaned, for preparing and coding the samples and presenting them to the taster in accordance with the appropriate experimental design, as well as for assembling and statistically processing the data obtained, so that the best results are obtained with the minimum of effort.

The work of the panel supervisor calls for sensory skill, meticulousness in the preparation of the tests and their rigorous arrangement, as well as for skill and patience in the planning and execution of the tests. It is the duty of the panel supervisor to stimulate the morale of the panel members by encouraging interests, curiosity and a competitive spirit among them. He shall ensure that his opinion is not known and shall prevent possible leaders from asserting their criteria over the other tasters. He shall also be responsible for training, selecting and monitoring the tasters in order to ascertain whether they are keeping up to an adequate level of aptitude.

**8.2. Test conditions****8.2.1. Sample size**

Each glass shall contain 15 ml of oil.

**8.2.2. Test temperature**

The oil samples to be tested shall be kept in the glasses at  $28\text{ °C} \pm 2\text{ °C}$ . This temperature has been chosen because it is the best for easily observing organoleptic differences, at normal temperature, when oils are used as a condiment. Another factor that tends to weigh in favour of this value is that at higher or lower temperatures either the aromatic components scarcely volatilize or volatile components are produced that are peculiar to heated oils.

**8.2.3. Test times**

The morning is the best time for testing oils. It has been proved that there are optimum perception periods as regards taste and smell during the day.

Meals are preceded by a period in which olfactory-gustatory sensitivity increases, whereas afterwards this perception decreases.

However, this criterion should not be taken to the extreme where hunger may distract the tasters, thus decreasing their discriminatory capacity and, in particular, their preference and acceptance criteria.

**9. TASTERS**

The people acting as tasters in the organoleptic tests carried out on edible olive oils shall be trained and selected in accordance with their skills in distinguishing between similar samples; it should be borne in mind that their accuracy will improve with training (see appropriate section).

Eight to 12 tasters are required for the test, although it is wise to keep some extra tasters in reserve to cover possible absences.

**▼B****9.1. General recommendations for candidates and tasters**

These recommendations apply to the conduct of the candidates and tasters during their work.

When called by the panel supervisor to participate in an organoleptic test, the taster should be able to attend at the time set beforehand and shall observe the following:

- 9.1.1. He shall not smoke at least 30 minutes before the time set for the test.
- 9.1.2. He shall not use any perfume, cosmetic or soap whose smell could linger until the time of the test. He shall use an unperfumed or slightly perfumed soap to wash his hands which he shall then rinse and dry as often as necessary to eliminate any smell.
- 9.1.3. He shall fast at least one hour before the tasting is carried out.
- 9.1.4. Should he feel physically unwell, and in particular if his sense of smell or taste is affected, or if he is under any psychological effect that prevents him from concentrating on his work, the taster shall inform the panel supervisor accordingly with a view to being withdrawn from the test or to the appropriate decisions being taken, bearing in mind the possible deviation in the mean values for the rest of the panel.
- 9.1.5. When he has complied with the above, the taster shall take up his place in the booth allotted to him in as orderly and quiet a manner as possible.
- 9.1.6. When seated, he shall check that he has the correct apparatus and that it is properly arranged, and shall ensure that the legend on the glass matches the legend on the watch-glass.
- 9.1.7. He shall carefully read the instructions given on the grading sheet and shall not begin to examine the sample until absolutely sure about the task he has to perform. If any doubts should arise, he shall discuss the difficulties encountered privately with the panel supervisor.
- 9.1.8. The taster shall pick up the glass, keeping it covered with the watch-glass, and shall bend it gently; he shall then rotate the glass fully in this position so as to wet the inside as much as possible. Once this stage is completed, he shall remove the watch-glass and smell the sample taking even, slow deep breaths until he has formed a criterion on the oil under assessment. Smelling shall not exceed 30 seconds. If no conclusion has been reached during this time, he shall take a short rest before trying again. When the olfactory test has been performed, the taster shall then judge the flavour (overall olfactory-gustatory-tactile sensation). To do so, he shall take a small sip of approximately 3 ml of oil. It is very important to distribute the oil throughout the whole of the mouth cavity, from the front part of the mouth and tongue along the sides to the back part and to the palate support, since it is a known fact that the perception of the four primary tastes, sweet, salty, acid and bitter varies in intensity depending on the area of the tongue and palate.

It should be stressed that it is essential for a sufficient amount of the oil to be spread very slowly over the back of the tongue towards the throat while the taster concentrates on the order in which the bitter and pungent stimuli appear; if this is not done, both of these stimuli may escape notice in some oils or else the bitter stimulus may be obscured by the pungent stimulus.

Taking short, successive breaths, drawing in air through the mouth, enables the taster not only to spread the sample extensively over the whole of the mouth but also to perceive the volatile aromatic components via the back of the nose.

Tactile sensation shall also be taken into consideration. Consequently, fluidity, stickiness and sharpness or sting shall be noted down when detected, and if so required for the test, their intensity shall be quantified.

- 9.1.9. When organoleptically assessing a virgin olive oil, only one sample shall be evaluated in each session to avoid the contrast effect that could be produced by immediately tasting other samples.

As successive tastings produce fatigue or loss of sensitivity, it is important to use a product that can eliminate the remains of the oil from the preceding tasting from the mouth.

The use of a small slice of apple (about 15 g) is recommended which, after being chewed, can be spat out into the spittoon. Then rinse out the mouth with a little water at ambient temperature. At least 15 minutes shall lapse between the end of one tasting and the start of the next.

**▼B****9.2. Screening of candidates.**

This stage shall be completed by the panel organizer who shall personally interview the candidates to familiarize himself with their personality and surrounding environment. The physio-psychological conditions that have to be met are not very rigorous since, theoretically, any normal person should be able to participate. Factors such as sex, age, specific habits (smoking), etc. have been superseded nowadays by others such as health, personal interest and having time available for the work.

During the interview, the panel organizer shall explain the characteristics of his task to the candidate and approximately how much time it will take up. He shall then obtain information from the candidate allowing him to assess his interest and motivation and how much real time he has available. The following questionnaire could help as a reference.

**QUESTIONNAIRE**

Please answer the following questions:

- |   | Yes                      | No                       |
|---|--------------------------|--------------------------|
| 1. Would you like to be involved in the work on this topic?   | <input type="checkbox"/> | <input type="checkbox"/> |
| 2. Do you think this work could contribute to the quality improvement of foodstuffs on the domestic and international fronts?   | <input type="checkbox"/> | <input type="checkbox"/> |
| 3. If so, why <sup>(1)</sup> .....  |                          |                          |
| .....   |                          |                          |
| .....   |                          |                          |
| 4. You should be aware of the fact that you will have to taste oils when called upon to do so. Would you be prepared to do this?  | <input type="checkbox"/> | <input type="checkbox"/> |
| 5. Would you like to compare your olfactory-gustatory skill with that of your colleagues?   | <input type="checkbox"/> | <input type="checkbox"/> |
| 6. Are you available time-wise? Are you independent enough to organize your daily work as you wish?   | <input type="checkbox"/> | <input type="checkbox"/> |
| 7. If you are dependent upon a superior, do you think that if you had to absent yourself from your usual job for anything up to half an hour, on several occasions over a successive number of days, you would be allowed to do so? | <input type="checkbox"/> | <input type="checkbox"/> |
| 8. Would you be able to make up for any time lost in your job due to your participation in the sensory analyses?  | <input type="checkbox"/> | <input type="checkbox"/> |
| 9. Do you think you should be remunerated for this work?  | <input type="checkbox"/> | <input type="checkbox"/> |
| 10. In what way?  | <input type="checkbox"/> | <input type="checkbox"/> |

(<sup>1</sup>)

The organiser shall use this information to screen the candidates and shall reject those who show little interest in this kind of work, are not readily available or who are incapable of expressing themselves clearly.

**9.3. Determination of the 'mean threshold' of the group for 'characteristic attributes'**

Carefully choose four oils, each one of which is considered representative of one of the following attributes: 'atrojado' (fusty), winey, rancid and bitter, and has as great and clear an intensity as possible.

Take an aliquot part of each oil and prepare samples, each of whose concentrations differs by a ratio of 2, comprising successive dilutions with the appropriate support until no difference can be detected between the glass containing the support only and the last two or three dilutions. The last pair shall be two glasses of the support.

(<sup>1</sup>) Describe what could be gained from the organoleptic assessment of any foodstuff, or, if you wish, of olive oil.

**▼B**

Complete the series with glasses containing higher concentrations, until a total of eight is reached.

Prepare sufficient amounts of the samples prepared at different concentrations so that complete series of each attribute can be given to each candidate.

To establish the 'mean threshold' of the candidates for each attribute, give each of them one glass containing 15 ml of any one of the prepared concentrations, and another glass containing 15 ml of the support solely. After performing the test, the candidate shall indicate whether they are the same or different.

Repeat the same test for the remaining concentrations of the attribute under consideration.

Note down the number of correct answers obtained for each concentration by all the tasters and give this figure as a percentage of the number of tests performed.

Then plot as abscissae, in ascending order, the concentrations tested and as ordinates the % of correct identifications for each concentration.

Figure 1 is a practical example of these instructions. The detection threshold is determined by extrapolating the ordinate point representing 75 % correct appraisals from the curve onto the abscissae.

This 'threshold' concentration, which may be different for each initial oil because it depends on the intensity of the attribute present, should be similar for the different groups of candidates to various panels; it is not linked to any habit or tendentious preference. Consequently, it is a point of reference common to any normal human group and may be used to homogenize the various panels by their olfactory-gustatory sensitivity alone.

On the basis of the threshold concentration obtained for the group, proceed as follows:

Prepare a series of increasing and decreasing concentrations in such a way that the 'threshold concentration' holds the 10th place in this scale. Naturally, the 11th and 12th concentrations will be more diluted, as a result of which it will be more difficult to detect the presence of the oil possessing the selected attribute.

Taking the  $C_{10}$  concentration as the basis, remaining samples can be prepared in accordance with the following formula:

$C_{10} \times a^n$ , where 'a' is a constant, the dilution factor, which is equal to 1,5, and 'n' is the exponent which varies between 9 and - 2.

Example: assuming that the threshold obtained for rancid oil is 0,32;  $C_{10} = 0,32$ , on the basis of which, since 'a' = 1,5, the series of samples would have the following concentrations:

Example	1	2	3	4	5	6	7	8	9	10	11	12
Concentration	12,30	8,20	5,47	3,65	2,43	1,62	1,08	0,72	0,48	0,32	0,21	0,14

If the above procedure is repeated for the three remaining attributes on the basis of their respective thresholds which are also calculated as indicated above, scales with similar aromatic intensities for each stimulus will be obtained for all the laboratories, even though the defects of the initial oils may be perceptible at different intensities.

#### 9.4. Selection of tasters by the intensity rating method

In the selection procedure, there should be two to three times more candidates than those required for the panel so that the people with the best sensitivity or powers of discrimination can be picked out. It is always advisable to use the same product as the one that is to be subsequently analysed (consequently, olive oil will always be used).

▼B

Figure 1

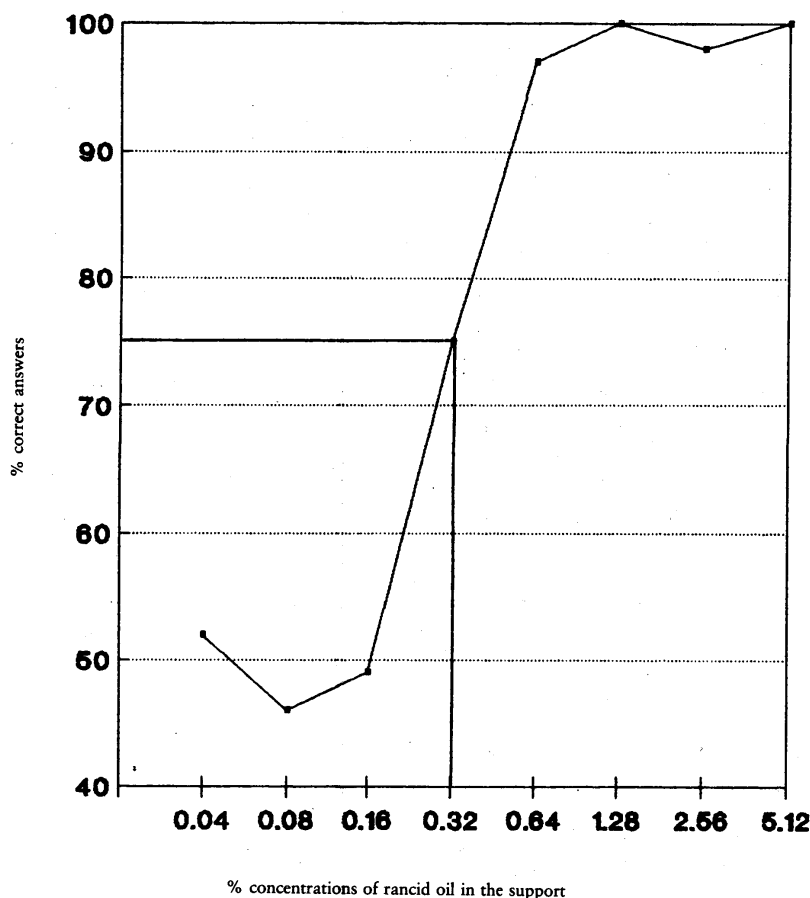

When selecting the method, it should not be overlooked that, apart from being effective, the procedure adopted should be as economical as possible as regards the quantity of oil, the number of samples to be sent and the time spent on selection. The effectiveness of a selection procedure lies in the choice of the optimum levels of the following three dependent variables: (a) 'cost' determined by the number of tests; (b) 'proportion' of potentially suitable candidates who by chance have been unfortunately eliminated during screening; and (c) 'proportion' of candidates who by chance have got through the selection process although unsuitable material.

Four points of the selection procedure chosen, the intensity rating test, which is described in the ASTM (American Society for Testing and Materials), STP (Special Technical Publication) No 440, page 53, have been modified by:

1. decreasing the number of samples in the series;
2. broadening the range of stimuli with a view to increasing the number of olfactory-gustatory notes on which selection is based, so as to adapt them to the most common defects perceived in olive oil;
3. varying the concentration ratios in the series; and
4. statistically processing the results.

*Apparatus required*

- 1 500 ml bottles or glass flasks,
- dark-coloured tasting glasses,
- graduated 10, 15, 1 000 and 1 500 ml test tubes.

*Products required*

- Merck paraffin (reference 7 160, DAB 8, USP XX) or oily support without taste or odour (recently refined olive oil or another similar oil),
- oils: 'atrojado' (fusty), winy, rancid and bitter.

**▼B**

9.4.1. Procedure

After preparing the dilutions, go on the selection stage beginning with 25 candidates, in accordance with the methodology described hereafter for each stimulus:

1. Prepare series of 12 tasting glasses marked with a code (one series per candidate). Pour 15 ml of each of the various concentrations prepared according to the formula  $C_{10} \times a^n$ , into each respective tasting glass.
2. When the tasting glasses have been filled up, they should be left covered with a watch-glass in the tasting room at a temperature of 20 to 22 °C for at least an hour before starting the tests so as to homogenize their temperature with the ambient temperature.
3. The organizer shall then arrange the 12 tasting glasses of each series in a row in descending order of concentration.

The next step is to ask each candidate to do the test on his own, in accordance with the following instructions:

9.4.2. Instructions for candidates

The 12 tasting glasses lined up in front of the candidates contain dilutions of any one of the 'atrojado' (fusty), winey, rancid or bitter stimuli. The distinguishing factor between the contents of the tasting glasses is the intensity of the odour. The glass with the most intense odour is on the far left-hand side and the rest of the glasses are placed in descending order of intensity towards the right. The last tasting glass on the right may have such a weak odour that it will perhaps be impossible to detect.

Proceed as follows: become familiar with the odour of each of the tasting glasses in the series. To do so, begin at the right hand side (No 12) and try to retain the intensity of all the odours, without becoming overtired.

When you feel that you have got used to the scale of concentrations of the odours, leave the room.

Meanwhile, the organizer shall remove one of the tasting glasses from the series and shall place it on a level with the last one on the right-hand side, moving all the others together so as to fill in the space left. Then return to the room and carry on with the test.

The test involves the following:

The tasting glass withdrawn from the series has to be put back in its exact place. To do so, smell it and compare it with the others as often as wished, bearing in mind that if it is to be replaced correctly it must smell stronger than the sample on its immediate right and weaker than that on its left. This test will be repeated with three other glasses.

Each candidate shall be issued a form, in addition to the instructions just described, so as to make the test and the collection of the replies easier.

*SELECTION OF CANDIDATES*

Test No ..... Attribute .....

The glass taken out belongs to position No .....

Date ..... Name .....

9.4.3. Obtaining the results

The panel organizer shall record the data for each of the candidates in the following manner to facilitate their arrangement:

Name of candidate	Attribute studied	No of order given (K')	Exact No of order (K)	Grading $(K' - K)^2$
.....	.....	.....	.....	.....
.....	.....	.....	.....	.....

▼**B**

## 9.4.4. Statistical grading procedure

In this particular selection case, the tasting glasses that have to be replaced in their exact position shall be the same for all the candidates. According to the statistical calculations done for this purpose, they shall correspond to the following positions in the order of the series as regards each attribute:

‘Atrojado’ — Fusty (Fy)	Winey (W)	Rancid (Rd)	Bitter (Bt)
Glass No (10, 5, 7, 2)	Glass No (11, 3, 8, 6)	Glass No (7, 4, 10, 2)	Glass No (6, 3, 11, 9)

The number corresponding to the position of the glasses in the order of the series may not vary since the statistical calculations for this test have been done with an eye to the probability of the glasses being randomly put back into their exact position.

In order to make it extremely difficult for any information to be passed on from one candidate to another, the panel organizer shall ensure that:

1. there is no possible means of contact between the candidates. Different legends shall be used for each candidate;
2. there is no way in which the candidates can find out the position of the glasses which have been withdrawn;
3. even though all the candidates shall be presented with the same glasses indicated earlier on, the order in which they are handed over to each candidate shall vary.

Each candidate shall then be given a grading, depending on his performance in the following manner:

Let  $e_1^i, e_2^i, \dots, e_{12}^i$  be the 12 glasses with the 12 corresponding concentrations of attribute ‘i’ (i may be any one of the four attributes: ‘atrojado’ — fusty, winey, rancid and bitter) arranged in descending order of intensity.

Let  $e_k^i$  be one of the glasses picked and  $K'$  the position it is allocated by the candidate when replaced in the series. Therefore, the values of  $K$  and  $K'$  are whole numbers between 1 and 12 inclusive, corresponding to the real place number of the glass chosen and that allocated by the candidate respectively.

Let  $T$  (maximum permitted deviation) be a value set beforehand, which in our case is equal to 3, so that if  $K' - K > T$ , the candidate is automatically rejected<sup>(1)</sup>.

If, on the contrary,  $K' - K \leq T$ , theoretically the candidate is accepted and may go on with the test since he or she is able to put the stimulus back into its exact position or at least very near it.

In this case, the grading awarded a candidate who has assessed a set stimulus (concentration), for instance in the ‘atrojado’ — fusty series (Fy), shall be equal to the square of the difference between the exact number of the glass in the order of the series and the position in which the candidate has replaced it. That is to say

$$P_h^{(Fy)} = (K' - K)^2.$$

Since this operation will be conducted by each candidate on four stimuli (concentrations) of each attribute, the partial grading for the attribute (e.g. Fy) would be:

$$Z^{Fy} = P_h^{Fy} + P_j^{Fy} + P_l^{Fy} + P_m^{Fy}$$

Some examples are given below to facilitate comprehension of this operation.

Example 1:

Let us assume that the answers given by candidate A for the four stimuli withdrawn from the series for attribute (i) are as follows:

<sup>(1)</sup> The panel organizer should press the candidate to proceed reasonably, that is to say without losing any sensitivity through olfactory fatigue.



▼B

Exact position of the glass in the series (K)	Position in which it was replaced by the candidate (K')	Deviation from the exact position (K'-K)
7	7	7 - 7 = 0
4	5	4 - 5 = - 1
10	6	10 - 6 = 4 ( <sup>1</sup> )
2	4	2 - 4 = - 2

(<sup>1</sup>) This candidate is rejected because he has obtained  $T > 3$  in the test.

Example 2:

Let us assume that a candidate rearranges the glasses for an attribute as follows:

Exact position of the glass in the series (K)	Position in which it was replaced by the candidate (K')	Deviation from the exact position (K'-K)
7	7	7 - 7 = 0
4	4	4 - 4 = 0
10	7	10 - 7 = 3
2	3	2 - 3 = - 1

This candidate is not rejected. He has obtained a grading of:

$$Z^i = 0^2 + 0^2 + 3^2 + (-1)^2 = 10$$

The candidate's final grading, sealing his acceptance or rejection or selection as a taster, depending on his responses to the four attributes under consideration, would be as follows:

$$\begin{aligned} P_h^{Fy} + P_j^{Fy} + P_l^{Fy} + P_m^{Fy} &= Z^{Fy} \\ P_h^W + P_j^W + P_l^W + P_m^W &= Z^W \\ P_h^{Rd} + P_j^{Rd} + P_l^{Rd} + P_m^{Rd} &= Z^{Rd} \\ P_h^{Bt} + P_j^{Bt} + P_l^{Bt} + P_m^{Bt} &= Z^{Bt} \end{aligned}$$

$$Z \text{ final} = Z^{Fy} \dots Z^{Bt}$$

Where:

Fy = 'Atrojado' — fusty

W = Winey

Rd = Rancid

Bt = Bitter

It is now a question of determining up to what maximum value for Z the candidate can be considered to have good levels of perception, olfactory retention and intellectual organization to give the correct answer for the four stimuli considered. Obviously, Z always has a non negative value and  $Z = 0$  means that the candidate has recognized and correctly quantified the whole of the 16 intensities presented (four for each attribute). Values of Z other than zero indicate that the candidate has recognized the scale areas from which the selected intensities have been picked, but within these areas has been unable to locate the exact position because his ability to discriminate the scale of intensity presented to him for one or more of the stimuli is not satisfactory.

Therefore, a critical value ( $Z_c$ ) will have to be determined such that should the candidate randomly replace all the glasses inside the areas he had recognized beforehand, the probability of a final grading Z, less than  $Z_c$ , is a sufficiently small quantity ( $\alpha$ ) which can be set beforehand. In other words, it must be ensured that the probability, using this procedure, of selecting a taster for the panel who does not show sufficient discriminatory power for the intensities of the stimuli used in the selection process is less than  $\alpha$ .

**▼B**

When the value for  $\alpha$  is set (in our case at 0,05),  $Z_c$  is obtained from the probability distribution of the variable  $Z$ , which in turn depends on the probability distributions of the  $P$  variables ( $K'$ ).

Following the relevant statistical calculations, the value for  $Z_c$  comes to 34.

When the  $Z$  grading for all the candidates has been obtained, any candidates whose grading lies above 34 shall be eliminated.

See the gradings for candidates A and B for an example:

Attribute	Candidate A	Candidate B
'Atrojado' — Fusty (Fy)	$Z^{Fy} = 10$	$Z^{Fy} = 12$
Winey (W)	$Z^W = 10$	$Z^W = 11$
Rancid (Rd)	$Z^{Rd} = 10$	$Z^{Rd} = 15$
Bitter (Bt)	$Z^{Bt} = 4$	$Z^{Bt} = 0$
	$\Sigma = 34$	$\Sigma = 38$

Given that the two candidates considered have respective  $Z$  values of 34 and 38, candidate A will be retained whereas candidate B will be rejected. When all the candidates with a grading above 34 have been eliminated, the remainder shall be classified according to their  $Z$  values until the 12 best candidates have been chosen.

#### 9.5. Training

The chief aims of the training stage are:

- (a) to familiarize the tasters with the multiple olfactory-gustatory-tactile variants found in virgin olive oils;
- (b) to familiarize the tasters with the specific sensory methodology;
- (c) to heighten individual skill in recognizing, identifying and quantifying the sensory attributes; and
- (d) to improve sensitivity and memory as regards the various attributes considered, so that the end result is precise and consistent assessments.

The training stage normally entails a number of sessions, depending on the possibilities open to the panel and the study, during which, after individually analysing the oils, the tasters discuss the difficulties they have encountered with the panel organizer and comment on the marks given so as to unify criteria and opinions.

The standard reached in training after a set number of sessions is assessed in terms of the percentage increase in the exact replies — should discriminatory trials be used — or by analysing the variance in the average individual marks of the panel when tests using a scale are implemented.

The practical utility of this training period has been discussed at great length but at present it is considered very effective and even essential if exact, accurate, sensory data are to be obtained.

#### 9.6. Performance checks

Panels of veteran tasters normally carry out tastings on a regular and continuous basis, involving sensory tests which require a great effort on their part. Decisions of great technological and commercial importance depend in a large majority of cases on their judgement. For this reason, after their selection and training, the tasters' performance should be checked to ensure that their results are precise.

After the panels have been set up and have gone through the routine trials, it would obviously be necessary to regularly check their performance at suitable intervals.

**▼B****10. PROCEDURE FOR THE ORGANOLEPTIC ASSESSMENT OF VIRGIN OLIVE OIL**

When the conditions indicated in the above standards are met, the necessary facilities are available and the panel has been selected, each taster shall smell and taste<sup>(1)</sup> the sample of oil up for analysis contained in the tasting glass. He shall analyse the olfactory, gustatory, tactile and kinaesthetic perceptions with the aid of the sheet shown under Figure 2 in which he shall record the 'notes' present and their degree of intensity. His next step shall be to grade the quality of the oil.

**10.1. Use of the sheet in Figure 2 (flavour description and quality grading).**

Some of the most characteristic sensory perceptions more frequently found in olive oils which describe their flavour are listed on the left-hand side of the page. Should the taster encounter any other stimuli that do not correspond to the descriptors listed, he shall note them down under 'others', using the descriptor (s) which define them as accurately as possible.

Perceptible stimuli shall be assessed in proportion to their intensity which shall be indicated by a cross (+) in the appropriate box, in accordance with the following criteria:

- 1: barely perceptible,
- 2: slight,
- 3: average,
- 4: great,
- 5: extreme.

On the right-hand side of the sheet, a scale from 1 to 9 points is shown (9 for exceptional quality, 1 for the worst) which the tasters shall use to give a single, overall grading for the characteristics of the oil being examined. This grading shall be consistent with the good points and defects of the oil already noted down on the left-hand side of the sheet.

The first column (defects) of the grading table is divided up into five sections. Consequently, the classification of the oils shall be based primarily on the total absence or presence of defective flavours, as well as on how serious or intense such flavours are. However, since the grading scale goes up to 9 points, certain nuances or aspects should be taken into account that help reach a conclusive decision on the total quality grading and that are described in the second column headed 'characteristics'.

**10.2. Final grading**

The panel supervisor shall collect the forms filled in by each taster and shall check that the sensory attributes and the intensities with which such attributes were perceived and recorded in the profile sheet agree with the assessment of the oil entered in the grading sheet. If there is a noticeable difference the supervisor shall ask the taster to check his grading sheet.

If necessary, the taster should repeat the test.

Finally, the panel supervisor should make up a table with the gradings for the whole group and calculate the arithmetic mean and the degree of error (of the mean).

Only in the case of revision analyses the group shall repeat the tests with a view to obtaining an assessment in triplicate of the sample; the final grade, with a decimal figure, will be the mean of the three gradings given.

If the mean intensity rating for bitterness and/or pungency is greater than 2,5, the oil should be marked accordingly and it should be recorded that it is bitter and/or pungent.

**▼M5**

*Expression of results:* on the basis of the average grading, the panel supervisor shall determine the category in which the sample is to be classified, in accordance with the limits laid down in Annex I. To that end

<sup>(1)</sup> He may refrain when he finds any extremely or intensely unpleasant attribute in the odour, recording this on the grading sheet as an exceptional occurrence.

**▼M5**

and save as otherwise provided in the second-to-last paragraph, the supervisor shall allow:

- a tolerance of + 1,5 during the 1992/93 marketing year,
- a tolerance of + 1 during the 1993/94 marketing year,
- a tolerance of + 0,5 during the 1994/95 marketing year,

if the average grading is 5 points or more.

However, in the case of oil which is the subject of intervention operations, the maximum tolerance during those marketing years shall be + 0,5.

The statistical difference in repeatability and reproducibility values between the analysis finding and the tolerance laid down by regulation shall fall within the tolerances specified in the preceding paragraphs.

Where, during the marketing years referred to above, the party concerned classifies oil without applying the tolerance laid down, he may state on the immediate packing the minimum organoleptic grading of the product verifiable during the marketing period.

The panel supervisor shall state in the analysis report only the category in which the sample is classified. An analyst who undertakes an examination in accordance with the first subparagraph of Article 2 (2) shall apply the same procedure for the determination of category.

**▼B**

*Note:* The samples should be kept sealed in the refrigerator until they are analysed and should be returned to the refrigerator after each analysis until the test has been done in triplicate.

▼ **M3**

**Figure 2**  
**Virgin olive oil**

Profile sheet  
Olfactory-gustatory-tactile notes

	Perception (1)					
	0	1	2	3	4	5
Olive fruity (ripe and green) (2)						
Apple .....						
Other ripe fruit .....						
Green (leaves, grass) .....						
Bitter .....						
Pungent .....						
Sweet .....						
Other allowable attribute(s) (Specify) .....						
.....						
Sour/winey/vinegary/acid (2) .....						
Rough .....						
Metallic .....						
Mustiness(2) .....						
Muddy sediment .....						
Fusty ("Atrojado") .....						
Rancid .....						
Other unallowable attribute(s) (Specify) .....						
.....						

(1) Perception :  
 0 = total absence (1)  
 1 = barely perceptible  
 2 = slight  
 3 = average  
 4 = great  
 5 = extreme

(2) Delete where not applicable.

(3) The absence of sensory perception must be indicated by putting a cross in the corresponding box.

Grading table

Defects	Characteristics	Overall marks points
None	Olive fruity	9
	Olive fruity and fruitiness of other fresh fruit	8
		7
Barely perceived	Weak fruitiness of any type	6
Perceived slightly	Rather imperfect fruitiness, anomalous odours and tastes	5
Perceived with average intensity	Clearly imperfect, unpleasant odours and tastes	4
Perceived with extreme intensity	Totally inadmissible odours and tastes for consumption	3
		2
		1

Remarks : .....

Name of taster : .....

Sample code : .....

Date : .....

▼ **B**

**SENSORY ANALYSIS: GENERAL BASIC VOCABULARY**

1. SCOPE

The purpose of this standard is to assemble the general terms used in sensory analysis and to give their definitions.

2. VOCABULARY

2.1. General terminology

*Sensory analysis* (noun):

examination of the organoleptic attributes of a product by the sense organs.

**▼B***Perception* (noun):

sensory awareness of external objects or events.

*Organoleptic* (adjective) (attribute):

describes an attribute of a product, perceptible by the sense organs.

*Expert* (noun):

(with regard to the examination of organoleptic attributes)

taster who is specialized in the sensory analysis of a specific product and has a basic understanding of the preparation of the product and market preferences.

*Taster* (noun):

perspicacious, sensitive, trained person selected to evaluate the organoleptic attributes of a food with the sense organs.

*Panel*:

group of assessors who have been specially selected and trained and who assemble to perform the sensory analysis of the product under controlled conditions.

*Sensation* (noun):

subjective phenomenon resulting from the stimulation of a sensory system. This phenomenon can be subjectively discriminated or objectively defined by the sense organ involved, depending on the nature or kind of stimulus, and its intensity.

*Sensitivity* (noun):

ability to perceive quantitatively and qualitatively a stimulus of little intensity or small differences between stimuli by means of the sense organs.

*Tasting* (noun):

operation which involves perceiving, analysing and judging the organoleptic attributes of a product, particularly the olfactory, gustatory, tactile and kinaesthetic attributes of a food product.

*Acceptance* (noun):

the act of an individual or population of favourably accepting a product.

*Harmony* (noun):

attribute of a product which gives rise to an overall pleasant sensation. This sensation is produced by the perception of the product components as olfactory, gustatory, tactile and kinaesthetic stimuli because they are present in suitable concentration ratios.

*Acceptability* (noun):

state of a product favourably received by an individual or population in terms of its organoleptic attributes.

*Discrimination* (noun):

the act of qualitative and/or quantitative differentiation between two or more stimuli.

*Compensation* (noun):

result of the interaction of a combination of stimuli in such a way that each one is perceived with less intensity than if it acted alone.

*Aspect* (noun):

combination of organoleptic attributes perceived visually: size, shape, colour, conformation, turbidness, cleanness, fluidness, foam and effervescence. This term is to be preferred to the term appearance.

*Attribute* (noun):

a perceptible characteristic.

## 2.2. Physiological terms

*Stimulus* (noun):

▼B

physical or chemical agent which specifically produces the response of the external or internal sensory receptors.

*Taste* (noun):

(sense of taste)

sense whose receptors are located in the mouth, particularly on the tongue, and which are activated by various compounds in solution.

*Gustatory* (adjective):

describes the attribute of a product which can stimulate the gustatory apparatus by-awakening the sensations pertaining to one or more of the four primary tastes: sweet, salty, acid and bitter.

*Receptor* (noun):

specific structure of a sense organ that can be excited and is capable of receiving a stimulus and converting it into a nervous discharge.

*Note:* Receptors are classified in terms of the type of energy associated with the stimulus (light, heat, sound, etc.).

*Olfaction* (noun):

function of the olfactory apparatus to perceive and discriminate between the molecules that reach it, in gas form from an external environment, directly or indirectly via the nose.

*Intensity* (noun):

magnitude of the energy of an attribute that can be measured in terms of a quantitative scale of values above the threshold.

*Adaptation* (noun):

temporary modification of sensitivity in perceiving sensory stimuli due to continuous, repeated exposure to a given stimulus or one similar to it.

*Inhibition* (noun):

lack of response by a sense organ or a part thereof, despite being subjected to the action of a suitable stimulus whose intensity is above the threshold.

*Response* (noun):

action whereby the sensory cells respond to the action of one or more stimuli related to a given sense organ.

*Body* (noun):

tactile sensation perceived in the mouth which gives a degree of density, viscosity, consistency or compactness to a product.

*Fragrance* (noun):

fresh, pleasant, delicious odour.

*To smell* (verb):

(active sense applied to smell)

describes the act of perceiving an odour.

*Objective* (adjective):

- (a) describes that which gives a true, verifiable representation of the object by minimizing the human factors (for instance, preference, habit, inclination);
- (b) describes the technique which, either by means of sensory or instrumental methods, minimizes self-induced errors.

*Note:* Use of the term 'instrumental' as a synonym is not advised.

*Subjective* (adjective):

describes that which produces a perception that is influenced not only by the stimulus but also by our way of thinking and feeling.

*Kinaesthesia:*

sensations resulting from pressure on the sample produced by a movement in the oral cavity or with the fingers (for example: pressing cheese with fingers)

*Threshold* (noun)

▼B*Absolute threshold:*

minimum value of a sensory stimulus which gives rise to:

- the appearance of a sensation (stimulus threshold or detection threshold), or
- the identification of the sensation (recognition threshold).

*Difference threshold:*

minimum value of a sensory stimulus which gives rise to a perceptible difference in the intensity of the sensation.

*Terminal threshold:*

maximum value of a stimulus above which an increase in intensity is not perceived.

*Preference threshold:*

minimum quantitative value of a stimulus or critical supra-threshold value of that stimulus at which an attraction or rejection response appears in relation to a neutral stimulus, for example, in the choice between a sugared solution and water.

*Note:* A distinction should be drawn between an absolute preference threshold and a differential preference threshold.

*Sub-threshold* (adjective):

below the absolute threshold.

*Supra-threshold* (adjective):

above the absolute threshold.

*Sensory fatigue:*

specific form of sensory adaptation in which a decrease in sensitivity occurs.

*Compensation* (noun):

result of the interaction of a combination of stimuli in such a way that each one is perceived with less intensity than if it acted alone.

*Synergic* (adjective):

joint effect or action of given substances in which the intensity of the organoleptic attributes resulting from the combination is in excess of the sum of the intensities of each attribute taken separately.

*Contrast effect:*

increase in response to differences between two simultaneous or consecutive stimuli.

Opposite of the convergence effect.

*Convergence effect:*

decrease in response to differences between two simultaneous or consecutive stimuli; opposite of contrast effect.

### 2.3. Terminology related to organoleptic attributes

*Acid* (adjective):

- (a) describes the primary taste produced by dilute aqueous solutions of most acid substances (for example, citric acid, lactic acid, tartaric acid);
- (b) describes the attribute of pure substances or mixtures which produces this taste.

The corresponding noun is acidity.

*Sour* (adjective):

describes the olfactory-gustatory sensation in which acids generally produced by fermentation are predominant, as well as the foodstuffs that produce this sensation.

Some factors that contribute to this sensation are related to the fermentation, for example the lactic or acetic fermentation, of a food product.

*Bitter* (adjective):



▼B

- (a) describes the primary taste produced by dilute aqueous solutions of various substances such as quinine, caffeine and given alkaloids.
- (b) describes the attribute of pure substances or mixtures which produces this taste.

The corresponding noun is bitterness.

*Salty* (adjective):

- (a) characteristic sensation perceived by the sense of taste, the most typical example of which is produced by a sodium chloride solution;
- (b) describes the attribute of pure substances or mixtures which produces this taste.

The corresponding noun is saltiness.

*Sweet* (adjective):

- (a) describes the primary taste produced by aqueous solutions of various substances such as sucrose;
- (b) describes the attribute of pure substances or mixtures which produces this taste.

The corresponding noun is sweetness.

*Astringent* (adjective):

- (a) describes the complex sensation produced in the mouth by a dilute aqueous solution of products such as some tannins (for example, kaki tannins and sloe tannins).
- (b) describes the attribute of pure substances or mixtures which produces this sensation.

(The corresponding noun is astringency).

*Flavour* (noun):

flavour means the combination of olfactory-gustatory-tactile and kinaesthetic sensations which enable an assessor to identify and establish a multi-level, favourable or unfavourable criterion.

*Taste* (noun):

- (a) sensations perceived when the gustatory papillae are stimulated by some soluble substances.
- (b) attribute of the specific sensation produced by such substances.

*Primary taste* (noun):

any one of the distinctive tastes of which there are held to be four: sweet, salty, acid, bitter.

*Odour* (noun):

- (a) combination of sensations perceived by the olfactory organ on sniffing given volatile substances;
- (b) attribute of the specific sensation produced by any one of the above substances.

*Aroma* (noun):

- (a) pleasant sensations perceived indirectly by the olfactory organ when tasting a food.
- (b) in perfumery and non-specialized language, this term is also applied to the same sensations perceived directly through the nose.

*After-taste; residual taste* (noun):

combination of sensations perceived after the stimulus has disappeared from the mouth and which differs from the sensations perceived beforehand.

*Aromatic* (adjective):

- (a) describes the attribute of pure substances or mixtures which when tasted produce the sensations known as aroma;
- (b) describes the products which when examined directly via the nose produce sensations of fragrance and freshness.

*Texture* (noun):

**▼B**

characteristics of the solid or rheological state of a product, the combination of which can stimulate the mechanical receptors during tasting, particularly those located in the mouth.

*Note:* This term refers solely to the objective attributes, not to the sensations produced which are designated by general terms such as consistency, fibrousness, greasiness, etc.

*Mouthwash:*

action whereby a food present in the mouth comes into contact with all the sensitive areas of the mouth so that the buccal sensations it produces can be perceived.

*Note:* This vocabulary may be enlarged by consulting ISO standards 5492, Parts I to V and other publications such as that by J. L. Magnen entitled *Les cahiers techniques du Centre National de Coordination des Etudes et Recherches sur la Nutrition et l'Alimentation*, etc.

## GLASS FOR OIL TASTING

### 1. SCOPE

The purpose of this standard is to describe the characteristics of the glass intended for use in the organoleptic analysis of edible oils (odour, taste, flavour).

In addition, it describes the adapted heating unit needed to reach and maintain the right temperature for this analysis.

### 2. DESCRIPTION OF THE GLASS

The drawing in Figure 1 attempts to establish the optimum characteristics desirable in a piece of apparatus of this kind, which can be specified as follows:

- (a) maximum steadiness, to prevent the glass from tilting and the oil from being spilled;
- (b) a base which easily fits the indentations of the heating unit so that the bottom of the glass is evenly heated;
- (c) a shape that is broadest at the base so that the volatile components of the oil are readily released but narrowed at the mouth so that the same components are easily concentrated, thus ensuring that they are better perceived and identified by the nose;
- (d) made of dark-coloured glass to prevent the taster from perceiving the colour of the oil, thus eliminating any prejudices and impeding the possible formation of biases or tendencies.

#### 2.1. Dimensions

The glass is sketched in Figure 1, and has the following dimensions:

— total capacity .....	130 ml ± 10 ml,
— total height .....	60 mm ± 1 mm,
— diameter of mouth .....	50 mm ± 1 mm,
— diameter of glass at its widest .....	70 mm ± 1 mm,
— base diameter .....	35 mm ± 1 mm,
— thickness of glass on sides .....	1,5 mm ± 0,2 mm,
— thickness of glass base .....	5 mm ± 1 mm.

Each glass shall be equipped with a watch-glass, the diameter of which shall be 10 mm larger than the mouth of the glass. This watch-glass shall be used as a cover to prevent the loss of aroma and the entry of dust.

#### 2.2. Manufacturing characteristics

The glass shall be made of resistant glass; it shall be dark-coloured so that the colour of its contents cannot be discerned, and shall be free from scratches or bubbles.

The rim shall be even, smooth and flanged.

The glass shall be annealed so that it stands the temperature changes it has to undergo in the tests.

▼B

## 2.3. Instructions for use

The glasses shall be cleaned using unperfumed soap or detergent and shall then be rinsed repeatedly until the cleaning agent has been totally eliminated. The final rinse shall be with distilled water, after which the glasses shall be left to drain and then dried in a desiccation stove.

Neither concentrated acids nor chromic acid mixtures shall be used.

The glasses shall be kept in the stove until required for use or shall be kept in a cupboard in which they shall be protected from contamination from any extraneous odours.

Before use, each glass shall be smelled to ensure that no extraneous odour is present. When the test is being prepared care shall be taken to record the legend of each glass and the oil it contains. The test organizer shall be the only person to know this legend/oil relation.

## 3. DEVICE FOR HEATING SAMPLES

The samples shall be organoleptically examined at a set temperature which, in the case of oils, shall be  $28 \pm 2^\circ \text{C}$ . For this purpose, a heating device (see Figure 2) shall be installed in each booth within the taster's reach. It comprises an aluminium block immersed in a thermostatically-controlled water bath so as to keep a constant temperature. This block has a series of indentations into which fit the bottoms of the glasses. The temperature difference between the heating device and the oil contained in the glasses inserted in the indentations of the various blocks shall not be more than  $\pm 2^\circ \text{C}$ .

Figure 1 — Tasting glass

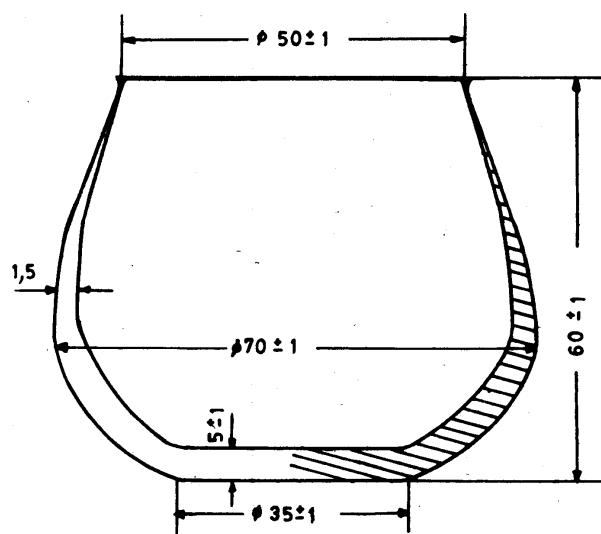

Dimensions (in mm)

▼B

Figure 2 — Device for heating samples (dimensions in millimetres)

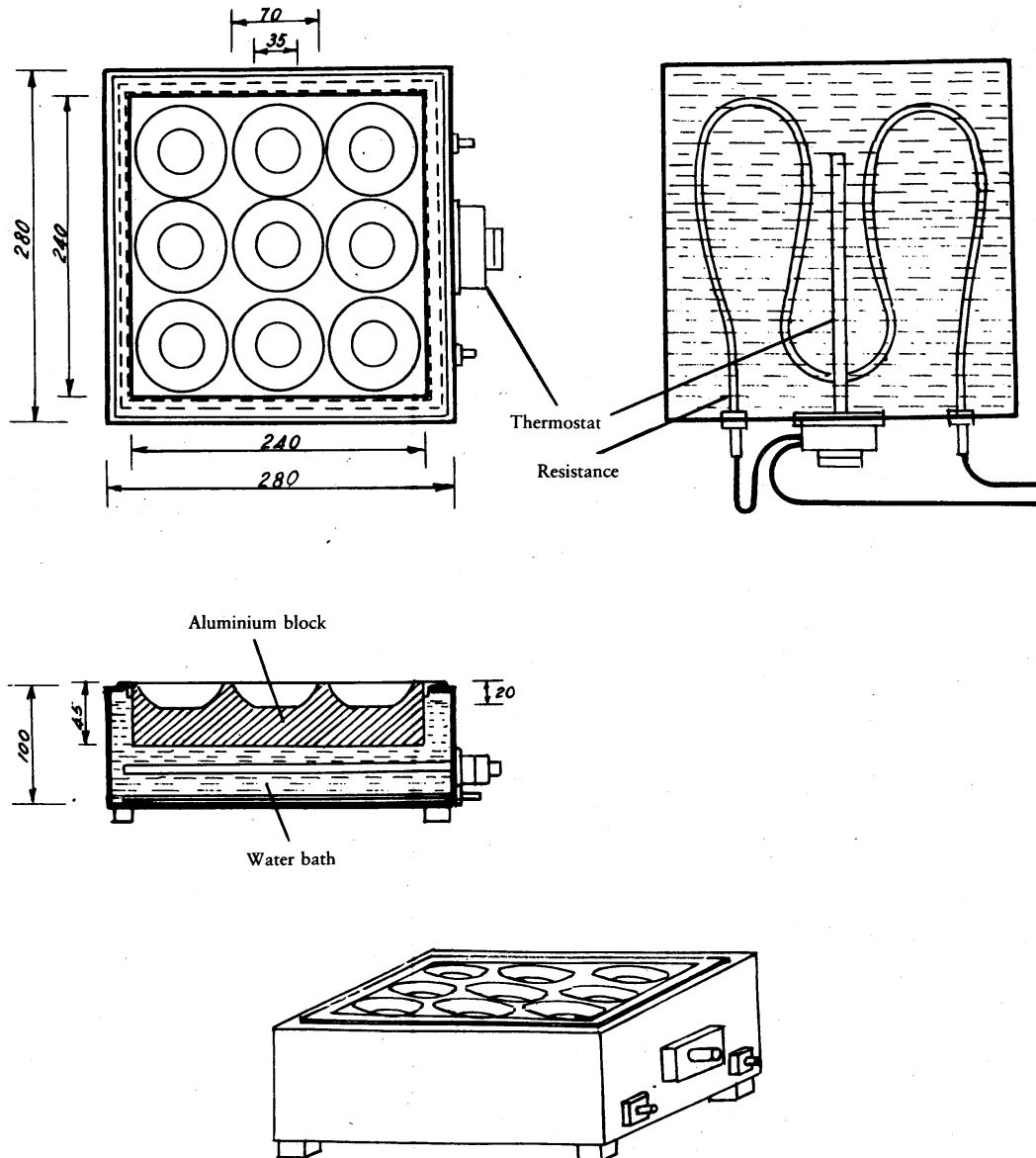

## GUIDE FOR THE INSTALLATION OF A TEST ROOM

### 1. INTRODUCTION

The test room is designed to provide the panel participating in the sensory tests with a suitable, comfortable, standardized environment which facilitates work and helps to improve the repeatability and reproducibility of the results.

### 2. SCOPE

The purpose of this standard is to specify the basic conditions that have to be met when installing a test room.

**▼B****3. GENERAL SPECIFICATIONS FOR INSTALLATION**

The premises, however large they are (see 3.1), shall meet the following specifications:

They shall be pleasant and suitably lighted (see 3.2) but neutral in style. For this purpose, a soothing, plain, light colour is recommended for the walls so that a relaxed atmosphere is created<sup>(1)</sup>.

The premises shall be such that they are easily cleaned and shall be separated from any source of noise; consequently, they shall preferably be soundproofed. They shall also be kept free from extraneous odours for which purpose, if possible, they shall be fitted with an effective ventilation device. If the fluctuations in ambient temperature so warrant, the test room shall be equipped with air conditioning to keep the atmosphere close to 20 to 22° C.

**3.1. Dimensions**

The dimensions of the premises often depend upon the possibilities of the laboratories or companies. Generally, they should be sufficiently spacious to permit the installation of 10 booths and an area for preparing the samples.

However, it is obvious that the larger the area set aside for the installations, the better, since auxiliary areas can then be provided, for instance, for cleaning apparatus, arranging culinary preparations and assembling open panels.

**3.2. Lighting**

General lighting, whether from sunlight or lamps (for instance, strip lighting) shall be uniform, controllable and diffuse.

**3.3. Temperature and hygrometric conditions**

The premises shall be kept constantly at a pleasant temperature and under agreeable hygrometric conditions. Except in special circumstances, a temperature of 20° to 22° C and hygrometric conditions of 60 to 70 % relative humidity are recommended.

**4. DESCRIPTION OF BOOTHS****4.1. General characteristics**

The sensory analysis booths shall be placed alongside each other in the premises. They shall be identical and shall be separated by partitions which shall be sufficiently high and wide as to isolate the tasters when seated.

The booths may be made of any appropriate material which is easily cleaned and looked after (for instance, wood, vitrified plywood, laminated panelling, etc.). If paint is used it must be completely odour-free when dry.

The seats provided in the booths shall be comfortable and shall have an adjustable height device.

Each booth shall also be provided with individual lighting, the direction and intensity of which may be adjusted.

It is highly recommended that the booths be equipped with a button connected to an outside light which enables the taster to make known to the attendant outside that he has finished the test, requires further samples, is missing a piece of apparatus, has noticed some irregularity, or wishes information, etc. without distracting the other tasters.

**4.2. Dimensions**

The booths shall be sufficiently large and comfortable. In general, they shall have the following dimensions:

- width:
  - 0,75 m (without sink)
  - 0,85 (with sink);

<sup>(1)</sup> The colour scheme of the room and its lighting can affect the results of the sensory analysis.

**▼B**

- length:
  - 0,50 m (table)
  - 0,20 m excess for partition;
- height of partitions:
  - 0,60 m minimum from table;
- height of table:
  - 0,75 m.

**4.3. Arrangement**

The table surface shall be such that it is easily cleaned.

Part of this surface shall be used for a sink provided with running drinking water. However, if this is not practicable, this space may be used for a tray, spittoon or similar piece of equipment.

When the samples have to be kept during the test at a constant temperature that is above or below ambient temperature, it is advisable to have a suitable device for this purpose (bain-marie, hot plate, etc.).

A shelf may also be set up at a height of approximately 1,10 metres from the floor for placing various accessories (glasses, small apparatus, etc.).

If the arrangement of the booths in the test room so permits, it is worthwhile installing a device to facilitate the presentations of the samples. This may be in the form of a sliding hatch (Figure 1), a revolving vertical device (Figure 2) suitable for glasses or cups (tall containers), or a horizontally-opening hatch when the containers in which the samples are kept are small (Figure 3). It is simply a question of ensuring that the opening is large enough for the trays and glasses containing the samples to pass through.

See Figure 4 for an example of a test room and additional premises.

**5. ADDITIONAL PREMISES**

If there is sufficient space, it is advisable to provide separate premises for preparing the samples (culinary or otherwise), arranging glasses or apparatus and holding discussions prior to or after the tests. If available, such premises shall be kept clean; in no way shall any smells, noise or conversations from these premises disturb the work of the assessors in the test room.

*Notes:* Ideal conditions are described. However, if it were not possible to have such an installation solely for sensory analyses, the tests could be performed in premises that meet the minimum conditions described (lighting, temperature, noise, odours) by setting up mobile booths made up of folding elements in such a way that, at the very least, they isolate the tasters from each other.

▼B

ARRANGEMENT OF THE BOOTH

Figure 1

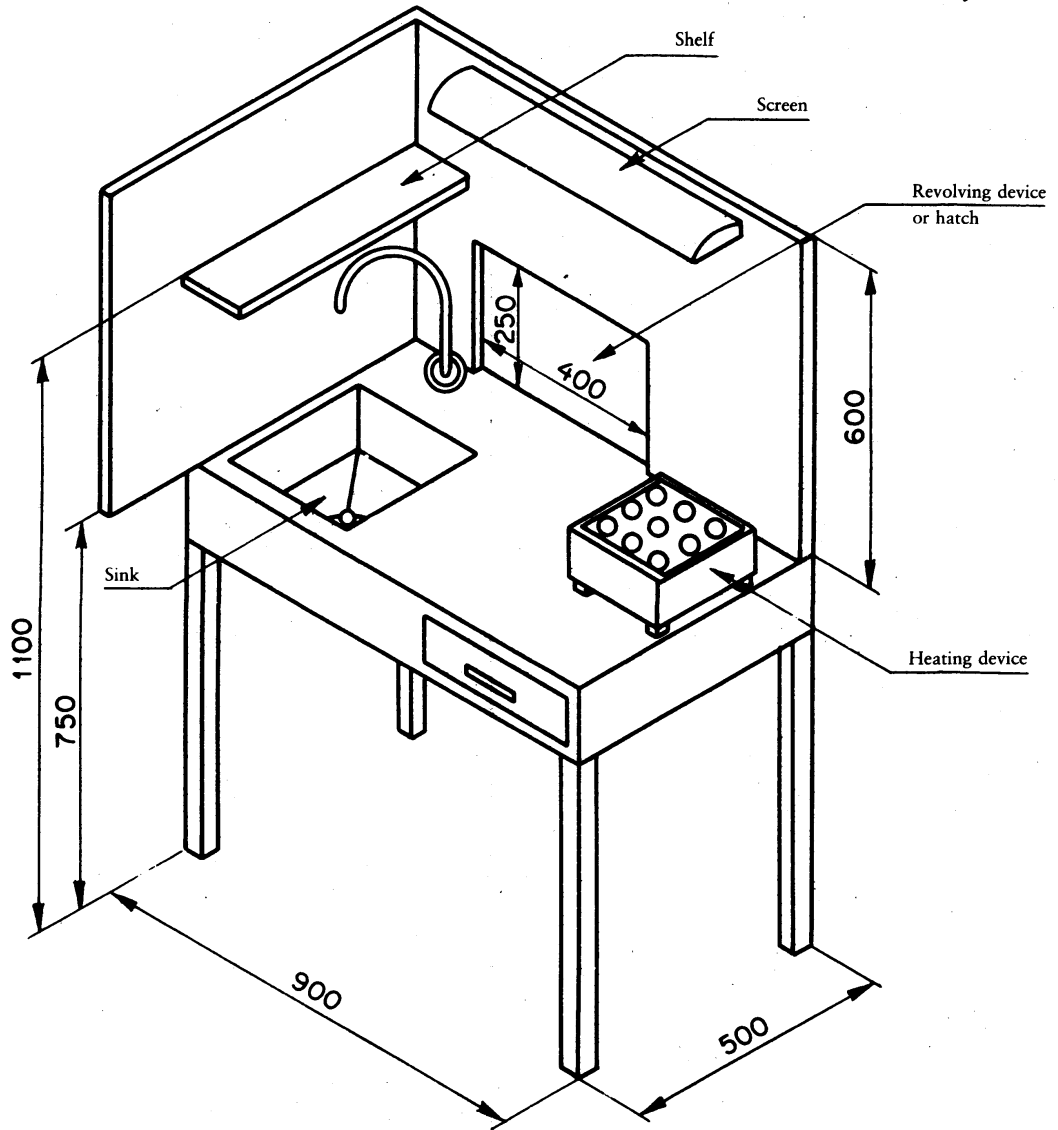

▼B

REVOLVING DEVICE FOR PRESENTING SAMPLES

Figure 2

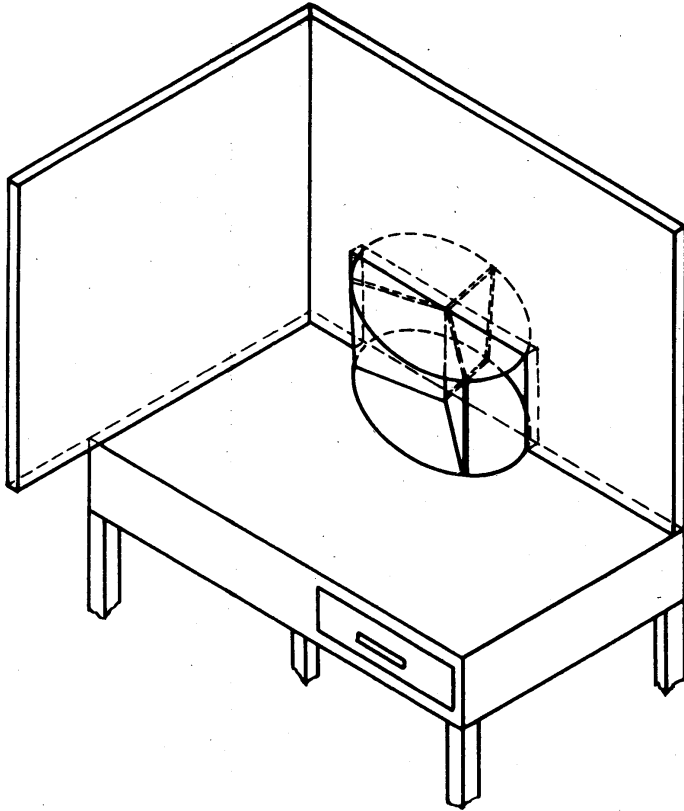



▼B

HATCH FOR PRESENTING SAMPLES

Figure 3

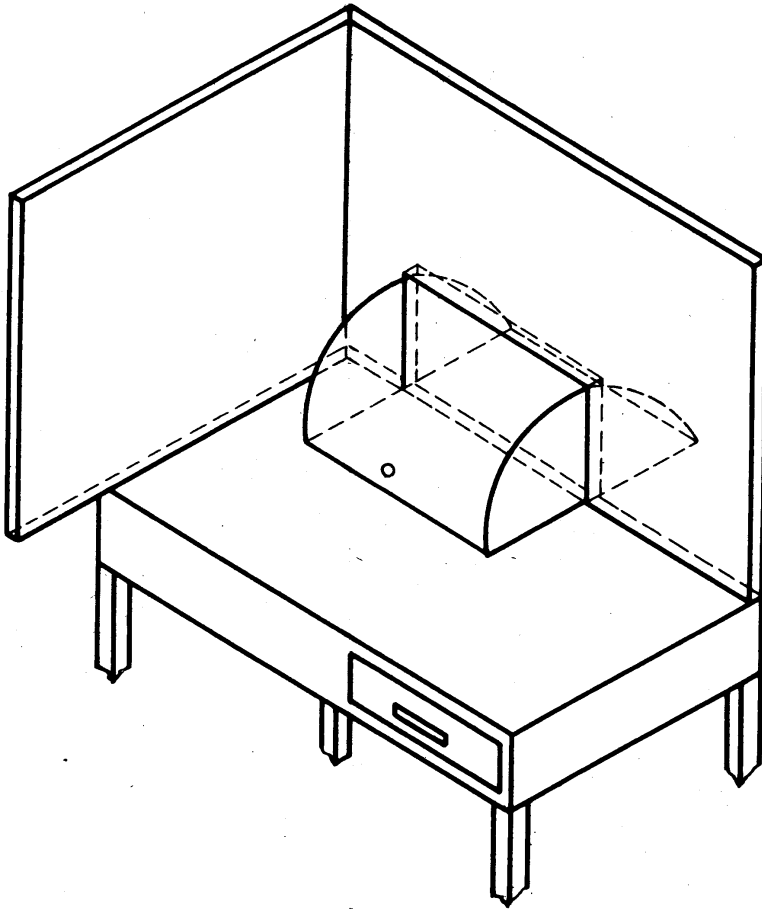

▼B

SENSORY ANALYSIS LABORATORY (Example)

Figure 4 — Example of a test room

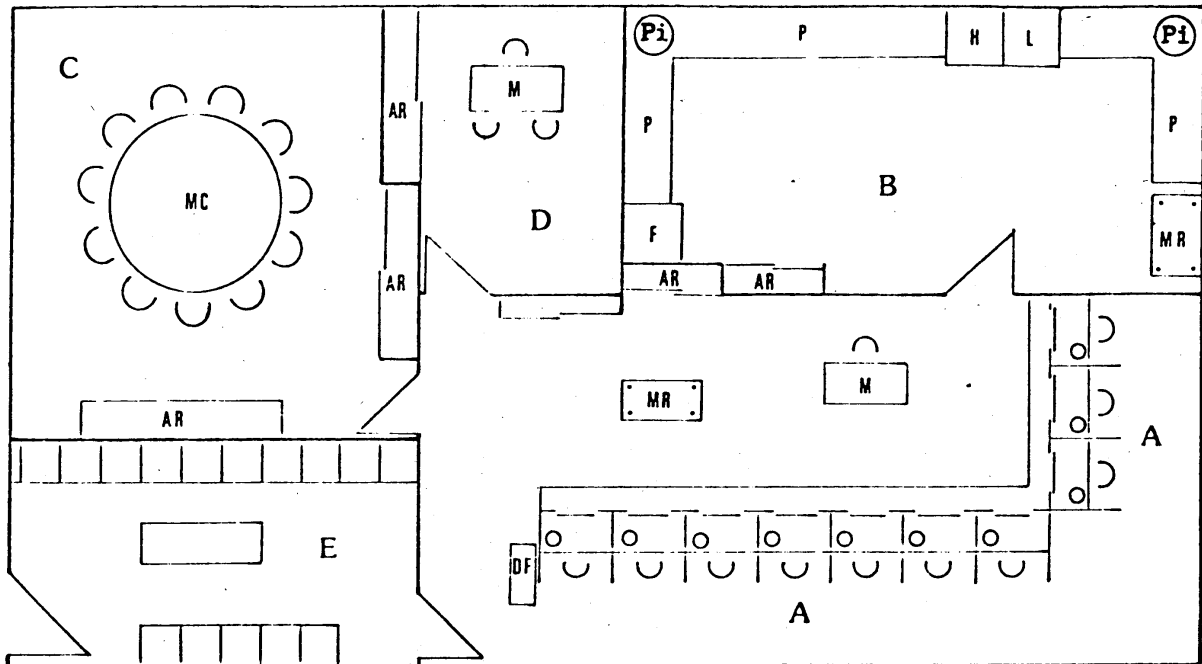

- A: tasting booths,
- B: room for cleaning apparatus and preparing samples,
- C: open panel,
- D: office,
- E: waiting room,
- F: refrigerator,
- H: oven,
- L: dishwasher,
- Pi: sink,
- AR: cupboard,
- MR: trolley,
- DF: distribution of forms,
- MC: round table,
- P: work surface.

▼B

## ANNEX XIII

▼M6

## NEUTRALIZATION AND DECOLORIZATION OF OLIVE OIL IN THE LABORATORY

▼B

## 1. NEUTRALIZATION AND DECOLORIZATION OF OLIVE OIL IN THE LABORATORY

## 1.1. Neutralization of the oil

## 1.1.1. Apparatus

- beaker, 300 ml, tall,
- laboratory centrifuge with 100 ml tubes,
- beaker, 250 ml,
- round-bottomed flasks, 100 ml,
- separating funnel, 1 litre.

## 1.1.2. Reagents

- aqueous solution of 12 % sodium hydroxide,
- ethyl alcohol solution of 1 % phenolphthalein,
- pure hexane, AR,
- pure propan-2-ol of AR.

## 1.1.3. Procedure

- (a) *Oils with a free fatty acid content, expressed as oleic acid, of less than 30 %*

Place 50 g of crude oil in a tall 300 ml beaker and heat to 65° C in a water bath. Add a quantity of 12 % solution of sodium hydroxide corresponding to the free acid of the oil, with an excess of 5 %, stirring gently all the time. Continue to stir for five minutes, keeping the temperature at 65° C.

Transfer the mixture into 100 ml centrifuge tubes and separate the soapy paste by centrifugation. Pour the decanted oil into a 250 ml beaker and wash with 50 to 60 ml of boiling distilled water, removing the water by means of a siphon. Repeat the washings until all traces of residual soap are removed (disappearance of the pink colouring in the phenolphthalein).

Centrifuge the oil to eliminate any small quantities of residual water.

- (b) *Oils with a free fatty acid content expressed as oleic acid exceeding 30 %.*

In a 1 litre separating funnel place 50 g of crude oil, 200 ml of hexane, 100 ml of propan-2-ol and a quantity of 12 % solution of sodium hydroxide corresponding to the free acid of the oil, with an excess of 0,3 %.

Stir vigorously for one minute. Add 100 ml of distilled water, stir again and allow to stand.

After separation of the layers, allow the lower layer containing soaps to drain off. Between the two layers (oily on top and aqueous underneath) an intermediary layer often forms made up of mucilages and insoluble substances which must also be eliminated.

## 1.2. Decolorization of neutralized oil

## 1.2.1. Apparatus

- round-bottomed flask, 250 ml, with three ground glass necks for the insertion of:
  - (a) a thermometer graduated in degrees and allowing readings to be taken at 90° C;
  - (b) a mechanical stirrer operating at 250 to 300 revolutions per minute, equipped to operate in a vacuum;
  - (c) a vacuum pump connection,
- vacuum pump, with a manometer, capable of giving residual pressure of 15 to 30 millibars.

**▼B**

## 1.2.2. Procedure

Weigh about 100 g of neutralized oil in the three-necked flask. Insert the thermometer and the stirrer, connect the vacuum pump and heat to 90° C, stirring all the time. Maintain that temperature, continuing to stir, until the oil to be analysed is entirely free from water (about 30 minutes). Then break the vacuum and add 2 to 3 g of activated earth.

Re-establish the vacuum until a residual pressure of 15 to 30 millibars is obtained and, maintaining a temperature of 90° C, stir for 30 minutes at about 250 revolutions per minute.

Filter while still hot in a thermostatic oven (50 to 60° C).

## ▼M6

## ANNEX XIV

## ADDITIONAL NOTES 2, 3 AND 4 TO CHAPTER 15 OF THE COMBINED NOMENCLATURE

2. A. Nos 1509 and 1510 cover only oils derived solely from the treatment of lives, the analytical characteristics of the acidic and sterol composition of which are as follows:

Table I: Fatty acid composition as percentage of total fatty acids		Table II: Sterol composition as percentage of total sterols	
Myristic acid	M 0,1	Cholesterol	M 0,5
Linolenic acid	M 0,9	Brassicasterol	M 0,2
Arachidic	M 0,7	Campesterol	M 4,0
Eicosanoic acid	M 0,5	Stigmasterol <sup>(1)</sup>	< Campesterol
Behenic acid	M 0,3	Betasitosterol <sup>(2)</sup>	m 93,0
Lignoceric acid	M 0,5	Delta-7-stigmastzerol	M 0,5

m = minimum  
M = Maximum

- (1) Condition not valid for virgin lampante oil (subheading 1509 10 10) and for olive-residue oil (subheading 1510 00 10).  
(2) Delta-5,23-Stigmastadienol + Cholesterol + Beta-Sitosterol + Sitostanol + Delta-5-Avenasterol + Delta-5,24-Stigmastadienol.

Nos 1509 and 1510 do not cover chemically altered olive oil (in particular re-esterified olive oil) and mixtures of olive oil with other oils. The presence of re-esterified olive oil or other oils is ascertained using the methods set out in Annexes V, VIII, X A and X B to Regulation (EEC) No 2568/91.

- B. Subheading 1509 10 covers only olive oils defined in Sections I and II below obtained solely using mechanical or other physical means under conditions, and particularly thermal conditions, that do not lead to deterioration of the oil, and which have undergone no treatment other than washing, decantation, centrifugation or filtration. Oils derived from olives using solvents fall under heading 1510.
- I. For the purposes of subheading 1509 10 10, 'virgin lampante olive oil', whatever its acidity, means olive oil with:
- an aliphatic alcohols content not exceeding 400 mg/kg;
  - an erythrodiol and uvaol content not exceeding 4,5 %;
  - a content in saturated fatty acids at the 2-position in the triglycerides not exceeding 1,3 %  
and/or
  - the sum of transoleic isomers lower than 0,10 % and the sum of translinoleic + translinolenic isomers lower than 0,10 %;
  - one or more of the following characteristics:
    - a peroxide number exceeding 20 meq O<sub>2</sub>/kg;
    - a content in volatile halogenated solvents exceeding 0,1 mg/kg for any one solvent;
    - a K<sub>270</sub> (100) extinction coefficient higher than 0,250 and, after treatment of the oil with activated alumina, not higher than 0,11. In point of fact some oils having a free fatty acid content, expressed as oleic acid, of more than 3,3 g per 100 g may, after passage through activated alumina, in accordance with the method set out in Annex IX to Regulation (EEC) No 2568/91, may have a K<sub>270</sub> extinction coefficient higher than 0,10. If so, after neutralization and decolorization in the laboratory, in accordance with the method set out in Annex XIII to the aforementioned Regulation, they must have the following characteristics:
      - aK<sub>270</sub> extinction coefficient not higher than 1,20,
      - an extinction coefficient variation (Delta K), in the 270 nm region, higher than 0,01 but not higher than 0,16, i.e.:

$$\text{Delta K} = K_m - 0,5 (K_{m-4} + K_{m+4})$$

▼ **M6**

$K_m$  = the extinction coefficient at the wavelength of the peak of the absorption curve in the 270 nm region,

$K_{m-4}$  en  $K_{m+4}$  = the extinction coefficients at wavelengths 4 nm lower and higher than the  $K_m$  wavelength;

(iv) organoleptic characteristics which include detectable defects exceeding the limits of acceptability and a panel test score lower than 3,5 in accordance with Annex XII to Regulation (EEC) No 2568/91.

II. For the purposes of subheading 1509 10 90, 'virgin oil' means olive oil having the following characteristics:

- (a) an acid content, expressed as oleic acid, not exceeding 3,3 g per 100 g;
- (b) a peroxide number not exceeding 20 meq active  $O_2$ /kg;
- (c) an aliphatic alcohols content not exceeding 300 mg/kg;
- (d) a content in volatile halogenated solvents not exceeding 0,2 mg/kg overall and not exceeding 0,1 mg/kg for each solvent;
- (e) a  $K_{270}$  extinction coefficient not higher than 0,250 and, after treatment of the oil with activated alumina, not higher than 0,10;
- (f) an extinction coefficient variation ( $\Delta K$ ), in the 270 nm region, not higher than 0,01;
- (g) organoleptic characteristics which may include detectable defects within the limits of acceptability and a panel test score higher than 3,5 in accordance with Annex XII to Regulation (EEC) No 2568/91;
- (h) an erythrodiol and uvaol content not exceeding 4,5 %;
- (i) a content in saturated fatty acids at the 2-position in the triglycerides not exceeding;
- (j) the sum of transoleic isomers lower than 0,03 % and the sum of translinoleic + translinolenic isomers lower than 0,03 %.

C. Subheading 1509 90 00 covers olive oil obtained by the treatment of olive oils falling within subheading 1509 10 10 or 1509 10 90, whether or not blended with virgin olive oil, having the following characteristics:

- (a) an acid content, expressed as oleic acid, not exceeding 3,3 g per 100 g;
- (b) an aliphatic alcohols content not exceeding 350 mg/kg;
- (c) A  $K_{270}$  extinction coefficient (100) higher than 0,250 and not higher than 1,20 and, after treatment of the sample with activated alumina, higher than 0,10;
- (d) an extinction coefficient variation ( $\Delta K$ ), in the 270 nm region, higher than 0,01 and not higher than 0,16;
- (e) an erythrodiol and uvaol content not exceeding 4,5 %;
- (f) a content in saturated fatty acids at the 2-position in the triglycerides not exceeding 1,5 %;
- (g) the sum of transoleic isomeres lower than 0,20 % and the sum of translinoleic + translinolenic isomeres lower than 0,30 %.

D. For the purposes of subheading 1510 00 10, 'crude oils' means oils, particularly olive residue oils, with the following characteristics:

- (a) an acid content, expressed as oleic acid, greater than 2 g per 100 g;
- (b) an erythrodiol and uvaol content exceeding 12 %;
- (c) a content in saturated fatty acids at the 2-position in the triglycerides not exceeding 1,8 %;
- (d) the sum of transoleic isomers lower than 0,20 % and the sum of translinoleic + translinolenic isomers lower than 0,10 %.

E. Subheading 1510 00 90 covers oils obtained by the treatment of oils falling within subheading 1510 00 10, whether or not blended with virgin olive oil, and oils not having the characteristics of the oils referred to in additional notes 2B, 2C and 2D. The oils falling within this subheading must have a content in saturated fatty acids at the 2-position in the triglycerides not exceeding 2 %, the sum of transoleic isomers lower than 0,4 % and the sum of translinoleic + translinolenic isomers lower than 0,35 %.

**▼M6**

3. Subheadings 1522 00 31 and 1522 00 39 do not cover:
  - (a) residues resulting from the treatment of fatty substances containing oil having in iodine index, determined in accordance with the method laid down in Annex XVI to Regulation (EEC) No 2568/91, lower than 70 or higher than 100;
  - (b) residues resulting from the treatment of fatty substances containing oil having an iodine index lower than 70 or higher than 100, of which the peak area representing the retention volume of Beta-Sitosterol<sup>(1)</sup>, determined in accordance with Annex V to Regulation (EEC) No 2568/91, is less than 93 % of the total sterol peak areas.
4. The analytical methods for the determination of the characteristics of the products referred to above are those laid down in the Annexes to Regulation (EEC) No 2568/91.

<sup>(1)</sup> Delta-5,23-Stigmastadienol + Cholesterol + Beta-Sitosterol + Sitostanol + Delta-5-Avenasterol + Delta-5,24-Stigmastadienol.

**▼B***ANNEX XV***1. OIL CONTENT OF OLIVE RESIDUE****1.1. Apparatus**

- suitable extraction apparatus fitted with a 200 to 250 ml round-bottomed flask,
- electrically heated bath (e.g., sand bath, water bath) or hotplate,
- analytical balance,
- oven regulated to a maximum of 80° C,
- electrically heated oven fitted with a thermostatic device regulated to  $103 \pm 2^\circ$  C and one that can be swept with a stream of air or operated at reduced pressure,
- mechanical mill, easy to clean, and one that allows the olive residues to be ground without a rise in their temperature or any appreciable alteration in their content of moisture, volatile matter or substances extractable with hexane,
- extraction thimble and cotton wool or filter paper from which substances extractable with hexane have already been removed,
- dessicator,
- sieve with 1 mm diameter apertures,
- small particles of previously dried pumice stone.

**1.2. Reagent**

Normal hexane, technical grade, which must leave a residue of less than 0,002 g per 100 ml, on complete evaporation.

**2. PROCEDURE****2.1. Preparation of the test sample**

If necessary, use the mechanical mill, which has previously been properly cleaned, to grind the laboratory sample in order to reduce it to particles that can pass completely through the sieve.

Use about one twentieth of the sample to complete the process of cleaning the mill, discard the ground material, grind the remainder and collect, mix carefully and analyze without delay.

**2.2. Test portion**

As soon as the grinding operation has been completed, weigh out about 10 g of the sample to the nearest 0,01 g for testing.

**2.3. Preparation of the extraction thimble**

Place the test portion in the thimble and plug with cotton wool. If a filter paper is used, envelope the test portion in it.

**2.4. Preliminary drying**

If the olive residues are very moist (i.e., moisture and volatile matter content more than 10 %), carry out preliminary drying by placing the loaded thimble (or filter paper) in the oven heated for an appropriate time at not more than 80° C in order to reduce the moisture and volatile matter content to less than 10 %.

**2.5. Preparation of the round-bottomed flask**

Weigh to the nearest 1 mg the flask containing one or two particles of pumice stone, previously dried in the stove at  $103 \pm 2^\circ$  C and then cooled in a dessicator for not less than one hour.

**2.6. Initial extraction**

Into the extraction apparatus insert the thimble (or filter paper) containing the test portion. Pour into the flask the requisite quantity of hexane. Fit the flask to the extraction apparatus and place the whole on the electrically heated bath. Adjust the rate of heating in such a way that the reflux rate is not less than three drops per second (moderate, not violent boiling). After four hours extraction, allow to cool. Remove the thimble from the extrac-



**▼B**

tion apparatus and place it in a stream of air in order to drive off most of the impregnating solvent.

**2.7. Second extraction**

Tip the contents of the thimble into the micro-grinder and grind as finely as possible. Return the ground mixture to the thimble without loss and place it back in the extraction apparatus.

Continue the extraction for a further two hours using the same round-bottomed flask containing the initial extract.

The resultant solution in the extraction flask must be clear. If not, filter it through a filter paper and wash the original flask and the filter paper several times with hexane. Collect the filtrate and the washing solvent in a second round-bottomed flask which has been dried and tared to the nearest 1 mg.

**2.8. Removal of solvent and weighing of extract**

Remove the greater part of the solvent by distillation on an electrically heated bath. Remove the last traces of solvent by heating the flask in the oven at  $103 \pm 2^\circ \text{C}$  for 20 minutes. Assist the elimination process either by blowing in air, or preferably an inert gas, at intervals or by using reduced pressure.

Leave the flask in a dessicator to cool for at least one hour and weigh to the nearest 1 mg.

Heat again for 10 minutes under the same conditions, cool in a dessicator and reweigh.

The difference between the two weighings shall not exceed 10 mg. If it does, heat again for periods of 10 minutes followed by cooling and weighing until the weight difference is 10 mg or less. Note the last weight of the flask.

Carry out duplicate determinations on the test sample.

**3. EXPRESSION OF RESULTS****3.1. Method of calculation and formula**

- (a) The extract expressed as a percentage by mass of the product as received is equal to:

$$S = m_1 \times \frac{100}{m_0}$$

where: S is the percentage by mass of extract of the product as received,

$m_0$  = is the mass, in grams, of the test portion,

$m_1$  = is the mass, in grams, of the extract after drying.

Take as the result the arithmetic mean of the duplicate determinations, providing the repeatability conditions are satisfied.

Express the result to the first decimal place.

- (b) The extract is expressed on a dry matter basis by using the formula:

$$S \times \frac{100}{100 - U} = \text{oil percentage of extract on a dry basis}$$

where:

S = is the percentage of extract by means of the product as received (see (a)),

U = is its moisture and volatile matter content.

**3.2. Repeatability**

The difference between the duplicate determinations carried out simultaneously or in rapid succession by the same analyst shall not exceed 0,2 g of hexane extract per 100 g of sample.

**▼B**

If this condition is not satisfied, repeat the analysis on two other test portions. If, in this case too, the difference exceeds 0,2 g, take as the result the arithmetic mean of the four determinations.



## ANNEX XVI

## DETERMINATION OF IODINE VALUE

## 1. SCOPE

This International Standard specifies a method for the determination of the iodine value of animal and vegetable fats and oils, referred to hereafter as fats.

## 2. DEFINITION

For the purposes of this International Standard, the following definition applies:

- 2.1. *iodine value*. The mass of iodine absorbed by the sample under the operating conditions specified in this International Standard.

The iodine value is expressed as grams of iodine per 100 g of sample.

## 3. PRINCIPLE

Dissolution of a test portion in solvent and addition of Wijs reagent. After a specified time, addition of potassium iodide solution and water, and titration of the liberated iodine with sodium thiosulfate solution.

## 4. REAGENTS

All reagents shall be of recognized analytical grade:

- 4.1. *water*, complying with the requirements of ISO 3696, Grade 3.
- 4.2. *potassium iodide*, 100 g/l solution, not containing iodate or free iodine.
- 4.3. *starch*, solution.
- Mix 5 g of soluble starch in 30 ml of water, add this mixture to 1 000 ml of boiling water, boil for three minutes and allow to cool.
- 4.4. *sodium thiosulfate*, standard volumetric solution  $c(\text{Na}_2\text{S}_2\text{O}_3 \cdot 5\text{H}_2\text{O}) = 0,1 \text{ mol/l}$ , standardized not more than seven days before use.
- 4.5. *solvent*, prepared by mixing equal volumes of cyclohexane and acetic acid.
- 4.6. *Wijs reagent*, containing iodine monochloride in acetic acid. Commercially available Wijs reagent shall be used.

## 5. APPARATUS

Usual laboratory apparatus and, in particular, the following:

- 5.1. *glass weighing scoops*, suitable for the test portion and for inserting into the flasks (6.2).
- 5.2. *conical flasks*, of 500 ml capacity, fitted with ground glass stoppers and completely dry.

## 6. PREPARATION OF THE TEST SAMPLE

The homogenized sample is dried over sodium sulphate and filtered.

## 7. PROCEDURE

## 7.1. Test portion

The mass of the test portion varies according to its expected iodine value as shown in Table 1.

▼**B**

Table 1

Expected iodine value	Mass of test portion (g)
less than 5	3,00
5 to 20	1,00
21 to 50	0,40
51 to 100	0,20
101 to 150	0,13
151 to 200	0,10

Weigh the test portion to the nearest 0,1 mg in a glass weighing scoop (5.1).

## 7.2. Determination

Place the test portion in a 500 ml flask (6.2). Add 20 ml of the solvent (4.5) to dissolve the fat. Add exactly 25 ml of the Wijs reagent (4.6), insert the stopper, swirl the contents and place the flask in the dark. Do not use a mouth pipette for the Wijs reagent.

Similarly, prepare a blank with the solvent and the reagent but omitting the test portion.

For samples having an iodine value below 150, leave the flasks in the dark for one hour; for those with an iodine value above 150 and for polymerized products or products oxidized to a considerable extent, leave for two hours.

At the end of the time, add 20 ml of the potassium iodide solution (4.2) and 150 ml of water (4.1) to each of the flasks.

Titrate with the standard volumetric sodium thiosulfate solution (4.4) until the yellow colour due to iodine has almost disappeared. Add a few drops of the starch solution (4.3) and continue the titration until the blue colour just disappears after very vigorous shaking.

*Note:* Potentiometric determination of the end point is permissible.

## 7.3. Number of determinations

Carry out two determinations on the same test sample.

## 8. EXPRESSION OF RESULTS

The iodine value is given by the expression

$$\frac{12,69 c (V_1 - V_2)}{m}$$

where:

$c$  = is the numerical value of the exact concentration, in moles per litre, of the standard volumetric sodium thiosulfate solution (4.4) used;

$V_1$  = is the numerical value of the volume, in millilitres, of the standard volumetric sodium thiosulfate solution (4.4) used for the blank test;

$V_2$  = is the numerical value of the volume, in millilitres, of the standard volumetric sodium thiosulfate solution (4.4) used for the determination;

$m$  = is the numerical value of the mass, in grams, of the test portion (7.1).

Take as the result the arithmetic mean of the two determinations, provided that the requirement for repeatability (9.2) is satisfied.