

Directive 2005/55/EC of the European Parliament and of the Council of 28 September 2005 on the approximation of the laws of the Member States relating to the measures to be taken against the emission of gaseous and particulate pollutants from compression-ignition engines for use in vehicles, and the emission of gaseous pollutants from positive-ignition engines fuelled with natural gas or liquefied petroleum gas for use in vehicles (Text with EEA relevance) (repealed)

ANNEX V

ANALYTICAL AND SAMPLING SYSTEMS

1. DETERMINATION OF THE GASEOUS EMISSIONS

1.1. Introduction

Section 1.2 and Figures 7 and 8 contain detailed descriptions of the recommended sampling and analysing systems. Since various configurations can produce equivalent results, exact conformance with Figures 7 and 8 is not required. Additional components such as instruments, valves, solenoids, pumps, and switches may be used to provide additional information and coordinate the functions of the component systems. Other components which are not needed to maintain the accuracy on some systems, may be excluded if their exclusion is based upon good engineering judgement.

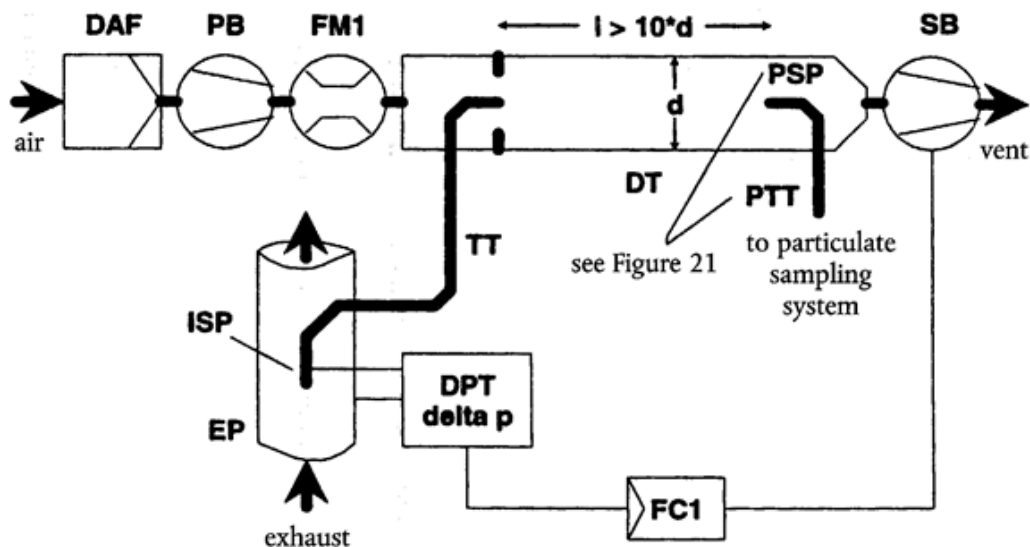

1.2. Description of the analytical system

An analytical system for the determination of the gaseous emissions in the raw (Figure 7, ESC only) or diluted (Figure 8, ETC and ESC) exhaust gas is described based on the use of:

- HFID analyser for the measurement of hydrocarbons;
- NDIR analysers for the measurement of carbon monoxide and carbon dioxide;
- HCLD or equivalent analyser for the measurement of the oxides of nitrogen.

The sample for all components may be taken with one sampling probe or with two sampling probes located in close proximity and internally split to the different analysers. Care must be taken that no condensation of exhaust components (including water and sulphuric acid) occurs at any point of the analytical system.

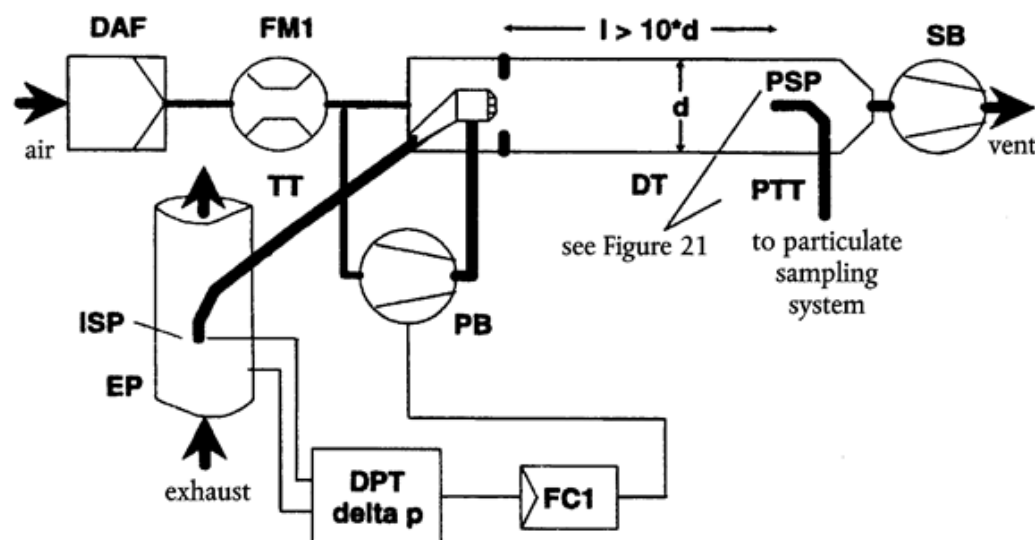

1.2.1. Components of Figures 7 and 8

EP Exhaust pipe

Exhaust gas sampling probe (Figure 7 only)

A stainless steel straight closed end multi-hole probe is recommended. The inside diameter shall not be greater than the inside diameter of the sampling line. The wall thickness of the probe shall not be greater than 1 mm. There shall be a minimum of three holes in three different radial planes sized to sample approximately the same flow. The probe must extend across at least 80 % of the diameter of the exhaust pipe. One or two sampling probes may be used.

SP2 Diluted exhaust gas HC sampling probe (Figure 8 only)

The probe shall:

- be defined as the first 254 mm to 762 mm of the heated sampling line HSL1;
- have a 5 mm minimum inside diameter;
- be installed in the dilution tunnel DT (see Section 2.3, Figure 20) at a point where the dilution air and exhaust gas are well mixed (i.e. approximately 10 tunnel diameters downstream of the point where the exhaust enters the dilution tunnel);
- be sufficiently distant (radially) from other probes and the tunnel wall so as to be free from the influence of any wakes or eddies;
- be heated so as to increase the gas stream temperature to $463 \text{ K} \pm 10 \text{ K}$ ($190 \text{ }^\circ\text{C} \pm 10 \text{ }^\circ\text{C}$) at the exit of the probe.

SP3 Diluted exhaust gas CO, CO₂, NO_x sampling probe (Figure 8 only)

The probe shall:

- be in the same plane as SP2;
- be sufficiently distant (radially) from other probes and the tunnel wall so as to be free from the influence of any wakes or eddies;
- be heated and insulated over its entire length to a minimum temperature of 328 K (55 °C) to prevent water condensation.

HSL1 Heated sampling line

The sampling line provides a gas sample from a single probe to the split point(s) and the HC analyser.

The sampling line shall:

Status: This is the original version (as it was originally adopted).

- have a 5 mm minimum and a 13,5 mm maximum inside diameter;
- be made of stainless steel or PTFE;
- maintain a wall temperature of 463 K \pm 10 K (190 °C \pm 10 °C) as measured at every separately controlled heated section, if the temperature of the exhaust gas at the sampling probe is equal to or below 463 K (190 °C);
- maintain a wall temperature greater than 453 K (180 °C), if the temperature of the exhaust gas at the sampling probe is above 463 K (190 °C);
- maintain a gas temperature of 463 K \pm 10 K (190 °C \pm 10 °C) immediately before the heated filter F2 and the HFID.

HSL2 Heated NO_x sampling line

The sampling line shall:

- maintain a wall temperature of 328 K to 473 K (55 °C to 200 °C), up to the converter C when using a cooling bath B, and up to the analyser when a cooling bath B is not used,
- be made of stainless steel or PTFE.

SL Sampling line for CO and CO₂

The line shall be made of PTFE or stainless steel. It may be heated or unheated.

BK Background bag (optional; Figure 8 only)

For the sampling of the background concentrations.

BG Sample bag (optional; Figure 8 CO and CO₂ only)

For the sampling of the sample concentrations.

F1 Heated pre-filter (optional)

The temperature shall be the same as HSL1.

F2 Heated filter

The filter shall extract any solid particles from the gas sample prior to the analyser. The temperature shall be the same as HSL1. The filter shall be changed as needed.

P Heated sampling pump

The pump shall be heated to the temperature of HSL1.

HC

Heated flame ionisation detector (HFID) for the determination of the hydrocarbons. The temperature shall be kept at 453 K to 473 K (180 °C to 200 °C).

CO, CO₂

NDIR analysers for the determination of carbon monoxide and carbon dioxide (optional for the determination of the dilution ratio for PT measurement).

NO

CLD or HCLD analyser for the determination of the oxides of nitrogen. If a HCLD is used it shall be kept at a temperature of 328 K to 473 K (55 °C to 200 °C).

C Converter

A converter shall be used for the catalytic reduction of NO₂ to NO prior to analysis in the CLD or HCLD.

B Cooling bath (optional)

To cool and condense water from the exhaust sample. The bath shall be maintained at a temperature of 273 K to 277 K (0 °C to 4 °C) by ice or refrigeration. It is optional if the analyser is free from water vapour interference as determined in Annex III, Appendix 5, Sections 1.9.1

and 1.9.2. If water is removed by condensation, the sample gas temperature or dew point shall be monitored either within the water trap or downstream. The sample gas temperature or dew point must not exceed 280 K (7 °C). Chemical dryers are not allowed for removing water from the sample.

T1, T2, T3 Temperature sensor

To monitor the temperature of the gas stream.

T4 Temperature sensor

To monitor the temperature of the NO₂-NO converter.

T5 Temperature sensor

To monitor the temperature of the cooling bath.

G1, G2, G3 Pressure gauge

To measure the pressure in the sampling lines.

R1, R2 Pressure regulator

To control the pressure of the air and the fuel, respectively, for the HFID.

R3, R4, R5 Pressure regulator

To control the pressure in the sampling lines and the flow to the analysers.

FL1, FL2, FL3 Flowmeter

To monitor the sample by-pass flow rate.

FL4 to FL6 Flowmeter (optional)

To monitor the flow rate through the analysers.

V1 to V5 Selector valve

Suitable valving for selecting sample, span gas or zero gas flow to the analysers.

V6, V7 Solenoid valve

To by-pass the NO₂-NO converter.

V8 Needle valve

To balance the flow through the NO₂-NO converter C and the by-pass.

V9, V10 Needle valve

To regulate the flows to the analysers.

V11, V12 Toggle valve (optional)

To drain the condensate from the bath B.

1.3. NMHC analysis (NG fuelled gas engines only)

1.3.1. Gas chromatographic method (GC, Figure 9)

When using the GC method, a small measured volume of a sample is injected onto an analytical column through which it is swept by an inert carrier gas. The column separates various components according to their boiling points so that they elute from the column at different times. They then pass through a detector which gives an electrical signal that depends on their concentration. Since it is not a continuous analysis technique, it can only be used in conjunction with the bag sampling method as described in Annex III, Appendix 4, Section 3.4.2.

For NMHC an automated GC with a FID shall be used. The exhaust gas shall be sampled into a sampling bag from which a part shall be taken and injected into the GC. The sample is separated into two parts (CH₄/Air/CO and NMHC/CO₂/H₂O) on the Porapak column. The molecular sieve

column separates CH_4 from the air and CO before passing it to the FID where its concentration is measured. A complete cycle from injection of one sample to injection of a second can be made in 30 s. To determine NMHC, the CH_4 concentration shall be subtracted from the total HC concentration (see Annex III, Appendix 2, Section 4.3.1).

Figure 9 shows a typical GC assembled to routinely determine CH_4 . Other GC methods can also be used based on good engineering judgement.

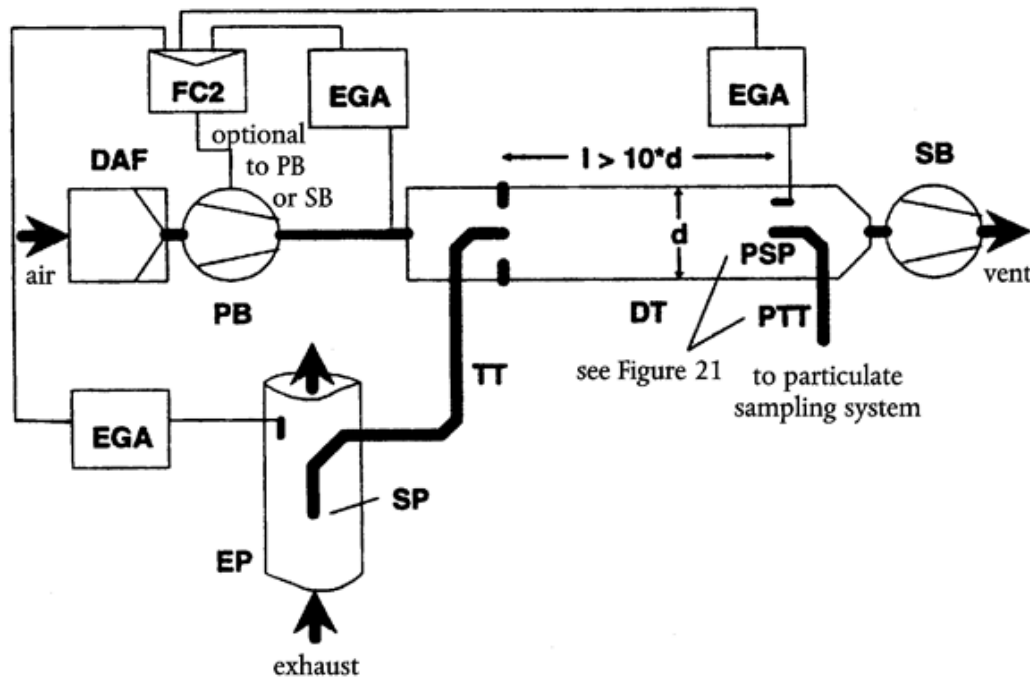

Components of Figure 9

PC Porapak column

Porapak N, 180/300 μm (50/80 mesh), 610 mm length \times 2,16 mm ID shall be used and conditioned at least 12 h at 423 K (150 $^{\circ}\text{C}$) with carrier gas prior to initial use.

MSC Molecular sieve column

Type 13X, 250/350 μm (45/60 mesh), 1 220 mm length \times 2,16 mm ID shall be used and conditioned at least 12 h at 423 K (150 $^{\circ}\text{C}$) with carrier gas prior to initial use.

OV Oven

To maintain columns and valves at stable temperature for analyser operation, and to condition the columns at 423 K (150 $^{\circ}\text{C}$).

SLP Sample loop

A sufficient length of stainless steel tubing to obtain approximately 1 cm^3 volume.

P Pump

To bring the sample to the gas chromatograph.

D Dryer

A dryer containing a molecular sieve shall be used to remove water and other contaminants which might be present in the carrier gas.

HC

Flame ionisation detector (FID) to measure the concentration of methane.

V1 Sample injection valve

To inject the sample taken from the sampling bag via SL of Figure 8. It shall be low dead volume, gas tight, and heatable to 423 K (150 C).

V3 Selector valve

To select span gas, sample, or no flow.

V2, V4, V5, V6, V7, V8 Needle valve

To set the flows in the system.

R1, R2, R3 Pressure regulator

To control the flows of the fuel (= carrier gas), the sample, and the air, respectively.

FC Flow capillary

To control the rate of air flow to the FID.

G1, G2, G3 Pressure gauge

To control the flows of the fuel (= carrier gas), the sample, and the air, respectively.

F1, F2, F3, F4, F5 Filter

Sintered metal filters to prevent grit from entering the pump or the instrument.

FL1

To measure the sample by-pass flow rate.

1.3.2. Non-methane cutter method (NMC, Figure 10)

The cutter oxidises all hydrocarbons except CH₄ to CO₂ and H₂O, so that by passing the sample through the NMC only CH₄ is detected by the FID. If bag sampling is used, a flow diverter system shall be installed at SL (see Section 1.2, Figure 8) with which the flow can be alternatively passed through or around the cutter according to the upper part of Figure 10. For NMHC measurement, both values (HC and CH₄) shall be observed on the FID and recorded. If the integration method is used, an NMC in line with a second FID shall be installed parallel to the regular FID into HSL1 (see Section 1.2, Figure 8) according to the lower part of Figure 10. For NMHC measurement, the values of the two FID's (HC and CH₄) shall be observed and recorded.

The cutter shall be characterised at or above 600 K (327 °C) prior to test work with respect to its catalytic effect on CH₄ and C₂H₆ at H₂O values representative of exhaust stream conditions. The dewpoint and O₂ level of the sampled exhaust stream must be known. The relative response of the FID to CH₄ must be recorded (see Annex III, Appendix 5, Section 1.8.2).

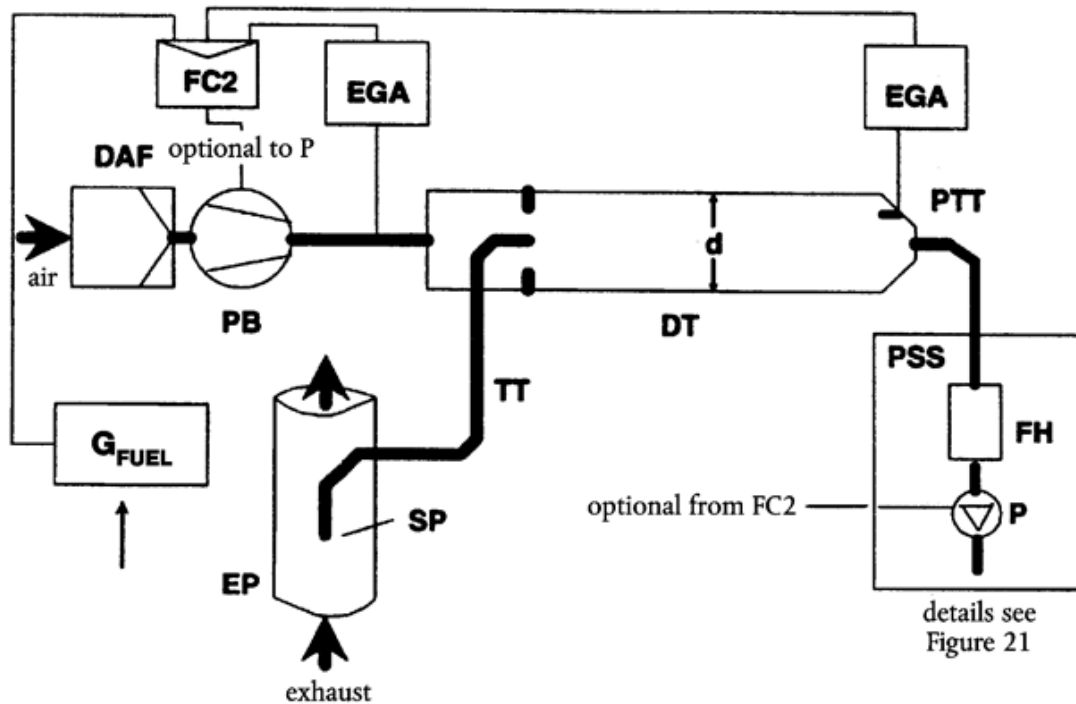

Components of Figure 10
NMC Non-methane cutter

To oxidise all hydrocarbons except methane.
HC

Heated flame ionisation detector (HFID) to measure the HC and CH₄ concentrations. The temperature shall be kept at 453 K to 473 K (180 °C to 200 °C).
V1 Selector valve

To select sample, zero and span gas. V1 is identical with V2 of Figure 8.
V2, V3 Solenoid valve

To by-pass the NMC.
V4 Needle valve

To balance the flow through the NMC and the by-pass.
R1 Pressure regulator

To control the pressure in the sampling line and the flow to the HFID. R1 is identical with R3 of Figure 8.
FL1 Flowmeter

To measure the sample by-pass flow rate. FL1 is identical with FL1 of Figure 8.

2. EXHAUST GAS DILUTION AND DETERMINATION OF THE PARTICULATES

2.1. Introduction

Sections 2.2, 2.3 and 2.4 and Figures 11 to 22 contain detailed descriptions of the recommended dilution and sampling systems. Since various configurations can produce equivalent results, exact conformance with these figures is not required. Additional components such as

instruments, valves, solenoids, pumps, and switches may be used to provide additional information and coordinate the functions of the component systems. Other components which are not needed to maintain the accuracy on some systems, may be excluded if their exclusion is based upon good engineering judgement.

2.2. Partial flow dilution system

A dilution system is described in Figures 11 to 19 based upon the dilution of a part of the exhaust stream. Splitting of the exhaust stream and the following dilution process may be done by different dilution system types. For subsequent collection of the particulates, the entire dilute exhaust gas or only a portion of the dilute exhaust gas is passed to the particulate sampling system (Section 2.4, Figure 21). The first method is referred to as total sampling type, the second method as fractional sampling type.

The calculation of the dilution ratio depends upon the type of system used. The following types are recommended:

Isokinetic systems (Figures 11, 12)

With these systems, the flow into the transfer tube is matched to the bulk exhaust flow in terms of gas velocity and/or pressure, thus requiring an undisturbed and uniform exhaust flow at the sampling probe. This is usually achieved by using a resonator and a straight approach tube upstream of the sampling point. The split ratio is then calculated from easily measurable values like tube diameters. It should be noted that isokinetic is only used for matching the flow conditions and not for matching the size distribution. The latter is typically not necessary, as the particles are sufficiently small as to follow the fluid streamlines.

Flow controlled systems with concentration measurement (Figures 13 to 17)

With these systems, a sample is taken from the bulk exhaust stream by adjusting the dilution air flow and the total dilute exhaust flow. The dilution ratio is determined from the concentrations of tracer gases, such as CO₂ or NO_x naturally occurring in the engine exhaust. The concentrations in the dilute exhaust gas and in the dilution air are measured, whereas the concentration in the raw exhaust gas can be either measured directly or determined from fuel flow and the carbon balance equation, if the fuel composition is known. The systems may be controlled by the calculated dilution ratio (Figures 13, 14) or by the flow into the transfer tube (Figures 12, 13, 14).

Flow controlled systems with flow measurement (Figures 18, 19)

With these systems, a sample is taken from the bulk exhaust stream by setting the dilution air flow and the total dilute exhaust flow. The dilution ratio is determined from the difference of the two flows rates. Accurate calibration of the flow meters relative to one another is required, since the relative magnitude of the two flow rates can lead to significant errors at higher dilution ratios (of 15 and above). Flow control is very straight forward by keeping the dilute exhaust flow rate constant and varying the dilution air flow rate, if needed.

When using partial flow dilution systems, attention must be paid to avoiding the potential problems of loss of particulates in the transfer tube, ensuring that a representative sample is taken from the engine exhaust, and determination of the split ratio. The systems described pay attention to these critical areas.

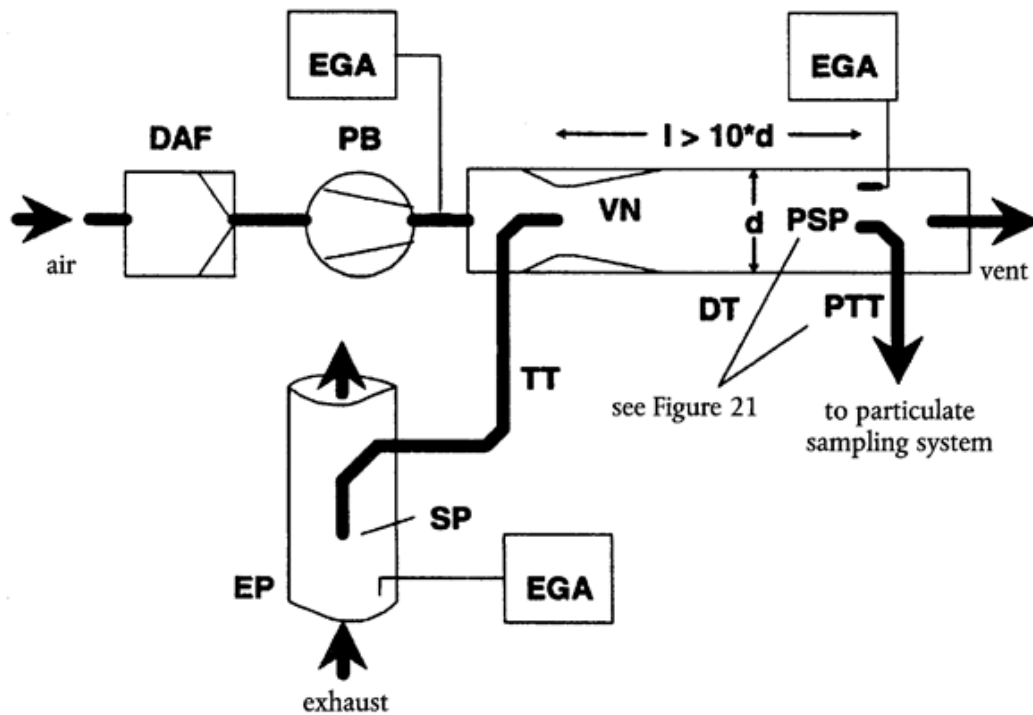

Raw exhaust gas is transferred from the exhaust pipe EP to the dilution tunnel DT through the transfer tube TT by the isokinetic sampling probe ISP. The differential pressure of the exhaust gas between exhaust pipe and inlet to the probe is measured with the pressure transducer DPT. This signal is transmitted to the flow controller FC1 that controls the suction blower SB to maintain a differential pressure of zero at the tip of the probe. Under these conditions, exhaust gas velocities in EP and ISP are identical, and the flow through ISP and TT is a constant fraction (split) of the exhaust gas flow. The split ratio is determined from the cross-sectional areas of EP and ISP. The dilution air flow rate is measured with the flow measurement device FM1. The dilution ratio is calculated from the dilution air flow rate and the split ratio.

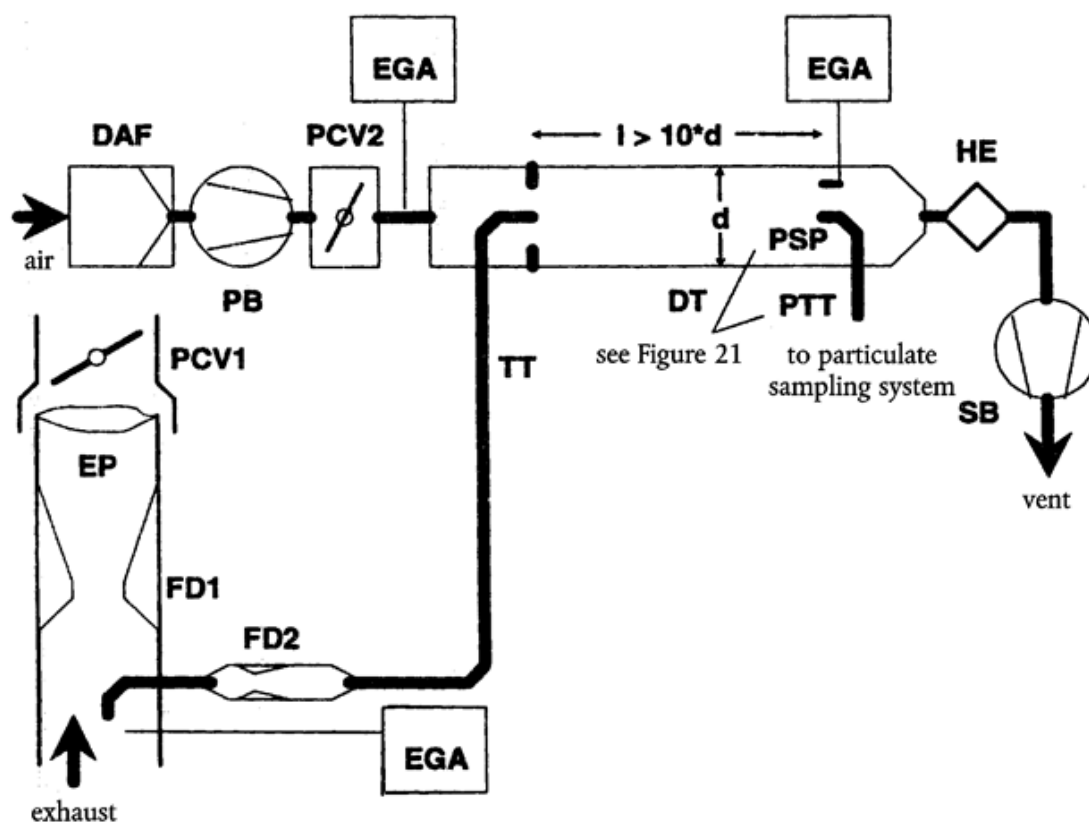

Raw exhaust gas is transferred from the exhaust pipe EP to the dilution tunnel DT through the transfer tube TT by the isokinetic sampling probe ISP. The differential pressure of the exhaust gas between exhaust pipe and inlet to the probe is measured with the pressure transducer DPT. This signal is transmitted to the flow controller FC1 that controls the pressure blower PB to maintain a differential pressure of zero at the tip of the probe. This is done by taking a small fraction of the dilution air whose flow rate has already been measured with the flow measurement device FM1, and feeding it to TT by means of a pneumatic orifice. Under these conditions, exhaust gas velocities in EP and ISP are identical, and the flow through ISP and TT is a constant fraction (split) of the exhaust gas flow. The split ratio is determined from the cross sectional areas of EP and ISP. The dilution air is sucked through DT by the suction blower SB, and the flow rate is measured with FM1 at the inlet to DT. The dilution ratio is calculated from the dilution air flow rate and the split ratio.

Status: This is the original version (as it was originally adopted).

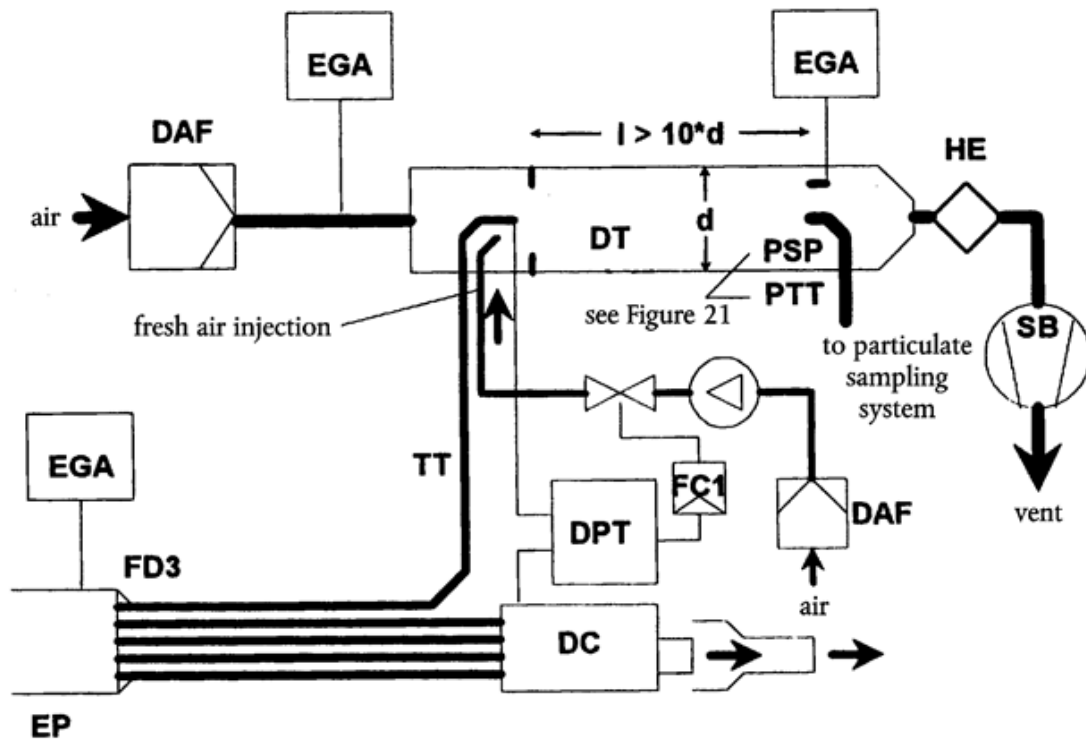

Raw exhaust gas is transferred from the exhaust pipe EP to the dilution tunnel DT through the sampling probe SP and the transfer tube TT. The concentrations of a tracer gas (CO_2 or NO_x) are measured in the raw and diluted exhaust gas as well as in the dilution air with the exhaust gas analyser(s) EGA. These signals are transmitted to the flow controller FC2 that controls either the pressure blower PB or the suction blower SB to maintain the desired exhaust split and dilution ratio in DT. The dilution ratio is calculated from the tracer gas concentrations in the raw exhaust gas, the diluted exhaust gas, and the dilution air.

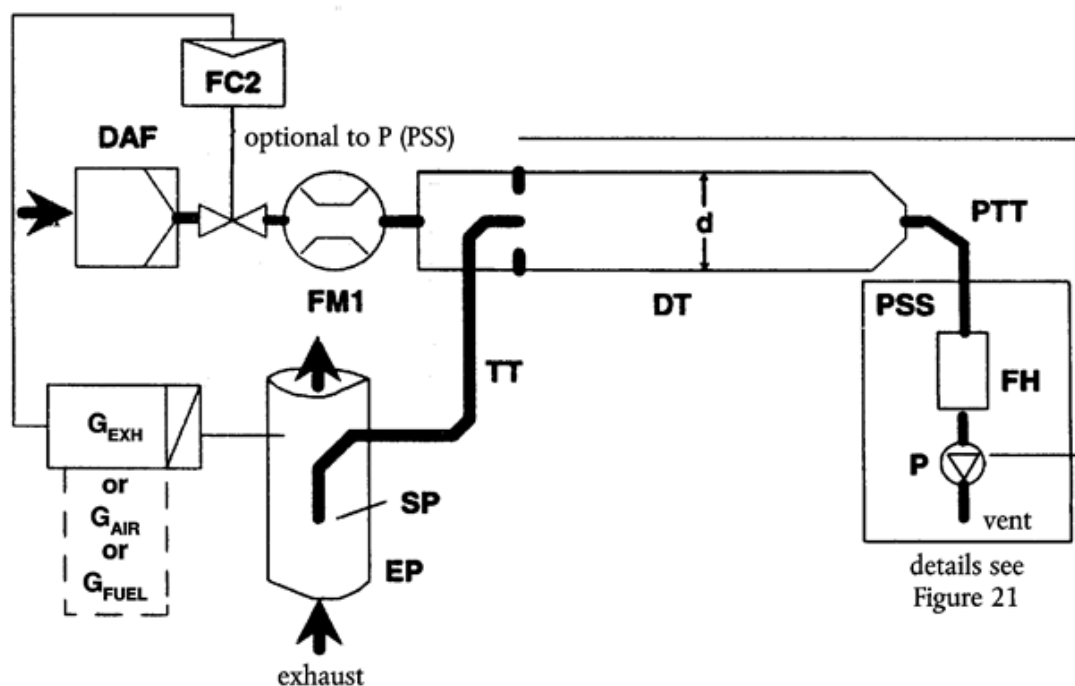

Raw exhaust gas is transferred from the exhaust pipe EP to the dilution tunnel DT through the sampling probe SP and the transfer tube TT. The CO₂ concentrations are measured in the diluted exhaust gas and in the dilution air with the exhaust gas analyser(s) EGA. The CO₂ and fuel flow G_{FUEL} signals are transmitted either to the flow controller FC2, or to the flow controller FC3 of the particulate sampling system (see Figure 21). FC2 controls the pressure blower PB, FC3 the sampling pump P (see Figure 21), thereby adjusting the flows into and out of the system so as to maintain the desired exhaust split and dilution ratio in DT. The dilution ratio is calculated from the CO₂ concentrations and G_{FUEL} using the carbon balance assumption.

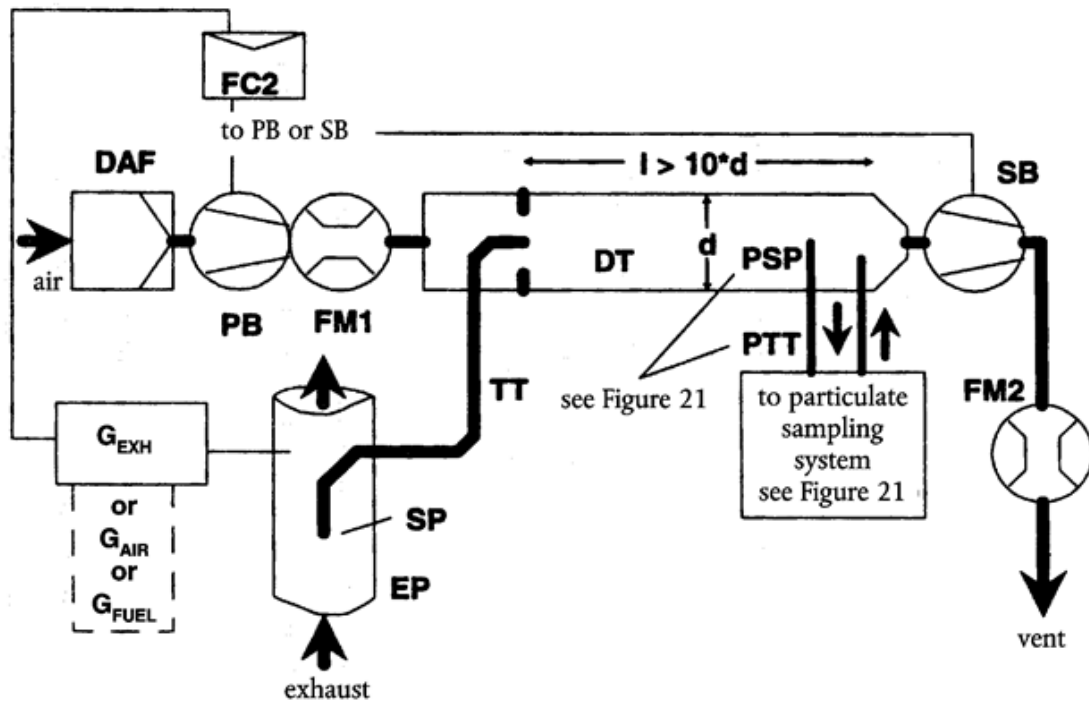

Raw exhaust gas is transferred from the exhaust pipe EP to the dilution tunnel DT through the sampling probe SP and the transfer tube TT due to the negative pressure created by the venturi VN in DT. The gas flow rate through TT depends on the momentum exchange at the venturi zone, and is therefore affected by the absolute temperature of the gas at the exit of TT. Consequently, the exhaust split for a given tunnel flow rate is not constant, and the dilution ratio at low load is slightly lower than at high load. The tracer gas concentrations (CO_2 or NO_x) are measured in the raw exhaust gas, the diluted exhaust gas, and the dilution air with the exhaust gas analyser(s) EGA, and the dilution ratio is calculated from the values so measured.

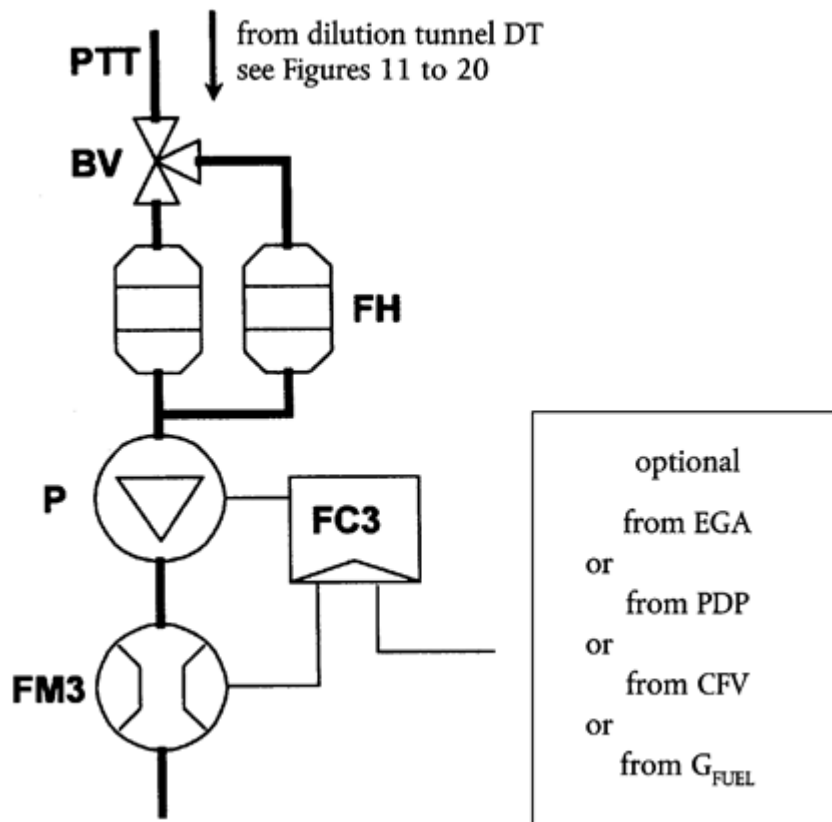

Raw exhaust gas is transferred from the exhaust pipe EP to the dilution tunnel DT through the transfer tube TT by the flow divider FD3 that consists of a number of tubes of the same dimensions (same diameter, length and bend radius) installed in EP. The exhaust gas through one of these tubes is lead to DT, and the exhaust gas through the rest of the tubes is passed through the damping chamber DC. Thus, the exhaust split is determined by the total number of tubes. A constant split control requires a differential pressure of zero between DC and the outlet of TT, which is measured with the differential pressure transducer DPT. A differential pressure of zero is achieved by injecting fresh air into DT at the outlet of TT. The tracer gas concentrations (CO_2 or NO_x) are measured in the raw exhaust gas, the diluted exhaust gas, and the dilution air with the exhaust gas analyser(s) EGA. They are necessary for checking the exhaust split and may be used to control the injection air flow rate for precise split control. The dilution ratio is calculated from the tracer gas concentrations.

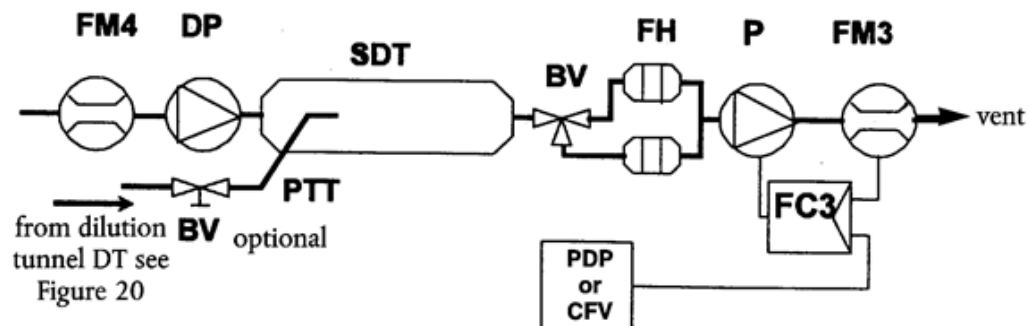

Raw exhaust gas is transferred from the exhaust pipe EP to the dilution tunnel DT through the sampling probe SP and the transfer tube TT. The total flow through the tunnel is adjusted with the flow controller FC3 and the sampling pump P of the particulate sampling system (see Figure 18). The dilution air flow is controlled by the flow controller FC2, which may use G_{EXHW} , G_{AIRW} , or G_{FUEL} as command signals, for the desired exhaust split. The sample flow into DT is the difference of the total flow and the dilution air flow. The dilution air flow rate is measured with the flow measurement device FM1, the total flow rate with the flow measurement device FM3 of the particulate sampling system (see Figure 21). The dilution ratio is calculated from these two flow rates.

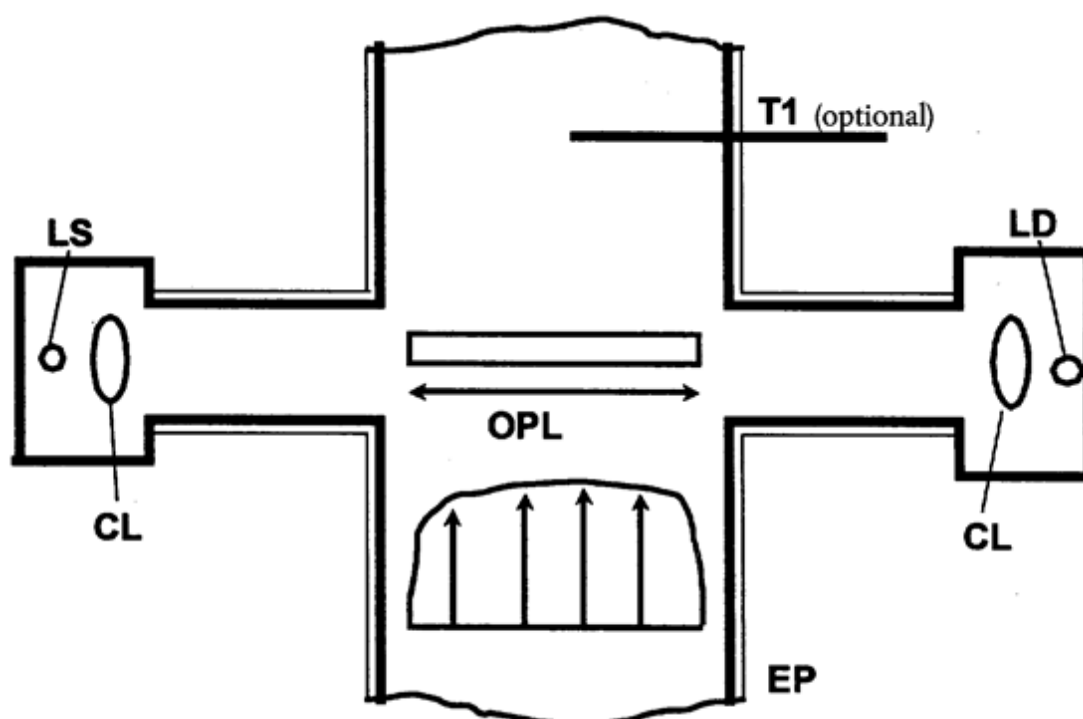

Raw exhaust gas is transferred from the exhaust pipe EP to the dilution tunnel DT through the sampling probe SP and the transfer tube TT. The exhaust split and the flow into DT is controlled by the flow controller FC2 that adjusts the flows (or speeds) of the pressure blower PB and the suction blower SB, accordingly. This is possible since the sample taken with the particulate sampling system is returned into DT. G_{EXHW} , G_{AIRW} , or G_{FUEL} may be used as command signals for FC2. The dilution air flow rate is measured with the flow measurement device FM1, the total flow with the flow measurement device FM2. The dilution ratio is calculated from these two flow rates.

2.2.1. Components of Figures 11 to 19 EP Exhaust pipe

The exhaust pipe may be insulated. To reduce the thermal inertia of the exhaust pipe a thickness to diameter ratio of 0,015 or less is recommended. The use of flexible sections shall be limited to a length to diameter ratio of 12 or less. Bends shall be minimised to reduce inertial deposition. If the system includes a test bed silencer the silencer may also be insulated.

For an isokinetic system, the exhaust pipe must be free of elbows, bends and sudden diameter changes for at least 6 pipe diameters upstream and 3 pipe diameters downstream of the tip of the probe. The gas velocity at the sampling zone must be higher than 10 m/s except at idle

mode. Pressure oscillations of the exhaust gas must not exceed ± 500 Pa on the average. Any steps to reduce pressure oscillations beyond using a chassis-type exhaust system (including silencer and aftertreatment devices) must not alter engine performance nor cause the deposition of particulates.

For systems without isokinetic probe, it is recommended to have a straight pipe of 6 pipe diameters upstream and 3 pipe diameters downstream of the tip of the probe.

SP Sampling probe (Figures 10, 14, 15, 16, 18, 19)

The minimum inside diameter shall be 4 mm. The minimum diameter ratio between exhaust pipe and probe shall be 4. The probe shall be an open tube facing upstream on the exhaust pipe centreline, or a multiple hole probe as described under SP1 in Section 1.2.1, Figure 5.

ISP Isokinetic sampling probe (Figures 11, 12)

The isokinetic sampling probe must be installed facing upstream on the exhaust pipe centreline where the flow conditions in section EP are met, and designed to provide a proportional sample of the raw exhaust gas. The minimum inside diameter shall be 12 mm.

A control system is necessary for isokinetic exhaust splitting by maintaining a differential pressure of zero between EP and ISP. Under these conditions exhaust gas velocities in EP and ISP are identical and the mass flow through ISP is a constant fraction of the exhaust gas flow. ISP has to be connected to a differential pressure transducer DPT. The control to provide a differential pressure of zero between EP and ISP is done with the flow controller FC1.

FD1, FD2 Flow divider (Figure 16)

A set of venturis or orifices is installed in the exhaust pipe EP and in the transfer tube TT, respectively, to provide a proportional sample of the raw exhaust gas. A control system consisting of two pressure control valves PCV1 and PCV2 is necessary for proportional splitting by controlling the pressures in EP and DT.

FD3 Flow divider (Figure 17)

A set of tubes (multiple tube unit) is installed in the exhaust pipe EP to provide a proportional sample of the raw exhaust gas. One of the tubes feeds exhaust gas to the dilution tunnel DT, whereas the other tubes exit exhaust gas to a damping chamber DC. The tubes must have the same dimensions (same diameter, length, bend radius), so that the exhaust split depends on the total number of tubes. A control system is necessary for proportional splitting by maintaining a differential pressure of zero between the exit of the multiple tube unit into DC and the exit of TT. Under these conditions, exhaust gas velocities in EP and FD3 are proportional, and the flow TT is a constant fraction of the exhaust gas flow. The two points have to be connected to a differential pressure transducer DPT. The control to provide a differential pressure of zero is done with the flow controller FC1.

EGA Exhaust gas analyser (Figures 13, 14, 15, 16, 17)

CO₂ or NO_x analysers may be used (with carbon balance method CO₂ only). The analysers shall be calibrated like the analysers for the measurement of the gaseous emissions. One or several analysers may be used to determine the concentration differences. The accuracy of the measuring systems has to be such that the accuracy of $G_{EDFW,i}$ is within ± 4 %.

TT Transfer tube (Figures 11 to 19)

The transfer tube shall be:

- as short as possible, but not more than 5 m in length,
- equal to or greater than the probe diameter, but not more than 25 mm in diameter,
- exiting on the centreline of the dilution tunnel and pointing downstream.

If the tube is 1 meter or less in length, it shall be insulated with material with a maximum thermal conductivity of 0,05 W/m*K with a radial insulation thickness corresponding to the diameter of the probe. If the tube is longer than 1 meter, it must be insulated and heated to a minimum wall temperature of 523 K (250 °C).

DPT Differential pressure transducer (Figures 11, 12, 17)

The differential pressure transducer shall have a range of ± 500 Pa or less.

FC1 Flow controller (Figures 11, 12, 17)

For isokinetic systems (Figures 11,12), a flow controller is necessary to maintain a differential pressure of zero between EP and ISP. The adjustment can be done by:

- (a) controlling the speed or flow of the suction blower SB and keeping the speed or flow of the pressure blower PB constant during each mode (Figure 11); or
- (b) adjusting the suction blower SB to a constant mass flow of the diluted exhaust gas and controlling the flow of the pressure blower PB, and therefore the exhaust sample flow in a region at the end of the transfer tube TT (Figure 12).

In the case of a pressure controlled system the remaining error in the control loop must not exceed ± 3 Pa. The pressure oscillations in the dilution tunnel must not exceed ± 250 Pa on the average.

For a multi-tube system (Figure 17), a flow controller is necessary for proportional exhaust splitting to maintain a differential pressure of zero between the exit of the multi-tube unit and the exit of TT. The adjustment is done by controlling the injection air flow rate into DT at the exit of TT.

PCV1, PCV2 Pressure control valve (Figure 16)

Two pressure control valves are necessary for the twin venturi/twin orifice system for proportional flow splitting by controlling the backpressure of EP and the pressure in DT. The valves shall be located downstream of SP in EP and between PB and DT.

DC Damping chamber (Figure 17)

A damping chamber shall be installed at the exit of the multiple tube unit to minimise the pressure oscillations in the exhaust pipe EP.

VN Venturi (Figure 15)

A venturi is installed in the dilution tunnel DT to create a negative pressure in the region of the exit of the transfer tube TT. The gas flow rate through TT is determined by the momentum exchange at the venturi zone, and is basically proportional to the flow rate of the pressure blower PB leading to a constant dilution ratio. Since the momentum exchange is affected by the temperature at the exit of TT and the pressure difference between EP and DT, the actual dilution ratio is slightly lower at low load than at high load.

FC2 Flow controller (Figures 13, 14, 18, 19, optional)

A flow controller may be used to control the flow of the pressure blower PB and/or the suction blower SB. It may be connected to the exhaust, intake air, or fuel flow signals and/or to the CO₂ or NO_x differential signals. When using a pressurised air supply (Figure 18), FC2 directly controls the air flow.

FM1 Flow measurement device (Figures 11, 12, 18, 19)

Gas meter or other flow instrumentation to measure the dilution air flow. FM1 is optional if the pressure blower PB is calibrated to measure the flow.

FM2 Flow measurement device (Figure 19)

Gas meter or other flow instrumentation to measure the diluted exhaust gas flow. FM2 is optional if the suction blower SB is calibrated to measure the flow.

PB Pressures blower (Figures 11, 12, 13, 14, 15, 16, 19)

To control the dilution air flow rate, PB may be connected to the flow controllers FC1 or FC2. PB is not required when using a butterfly valve. PB may be used to measure the dilution air flow, if calibrated.

SB Suction blower (Figures 11, 12, 13, 16, 17, 19)

For fractional sampling systems only. SB may be used to measure the diluted exhaust gas flow, if calibrated.

DAF Dilution air filter (Figures 11 to 19)

It is recommended that the dilution air be filtered and charcoal scrubbed to eliminate background hydrocarbons. At the engine manufacturers request the dilution air shall be sampled according to good engineering practice to determine the background particulate levels, which can then be subtracted from the values measured in the diluted exhaust.

DT Dilution tunnel (Figures 11 to 19)

The dilution tunnel:

- shall be of a sufficient length to cause complete mixing of the exhaust and dilution air under turbulent flow conditions;
- shall be constructed of stainless steel with:
 - thickness/diameter ratio of 0,025 or less for dilution tunnels with inside diameters greater than 75 mm;
 - a nominal thickness of no less than 1,5 mm for dilution tunnels with inside diameters of equal to or less than 75 mm;
- shall be at least 75 mm in diameter for the fractional sampling type;
- is recommended to be at least 25 mm in diameter for the total sampling type;
- may be heated to no greater than 325 K (52 °C) wall temperature by direct heating or by dilution air pre-heating, provided the air temperature does not exceed 325 K (52 °C) prior to the introduction of the exhaust in the dilution tunnel;
- may be insulated.

The engine exhaust shall be thoroughly mixed with the dilution air. For fractional sampling systems, the mixing quality shall be checked after introduction into service by means of a CO₂-profile of the tunnel with the engine running (at least four equally spaced measuring points). If necessary, a mixing orifice may be used.

Note: If the ambient temperature in the vicinity of the dilution tunnel (DT) is below 293K (20 °C), precautions should be taken to avoid particle losses onto the cool walls of the dilution tunnel. Therefore, heating and/or insulating the tunnel within the limits given above is recommended.

At high engine loads, the tunnel may be cooled by a non-aggressive means such as a circulating fan, as long as the temperature of the cooling medium is not below 293K (20 °C).

HE Heat exchanger (Figures 16, 17)

The heat exchanger shall be of sufficient capacity to maintain the temperature at the inlet to the suction blower SB within $\pm 11\text{K}$ of the average operating temperature observed during the test.

2.3. Full flow dilution system

A dilution system is described in Figure 20 based upon the dilution of the total exhaust using the CVS (Constant Volume Sampling) concept. The total volume of the mixture of exhaust and dilution air must be measured. Either a PDP or a CFV system may be used.

For subsequent collection of the particulates, a sample of the dilute exhaust gas is passed to the particulate sampling system (section 2.4, figures 21 and 22). If this is done directly, it is referred to as single dilution. If the sample is diluted once more in the secondary dilution tunnel, it is referred to as double dilution. This is useful, if the filter face temperature requirement cannot be met with single dilution. Although partly a dilution system, the double dilution system is described as a modification of a particulate sampling system in section 2.4, Figure 22, since it shares most of the parts with a typical particulate sampling system.

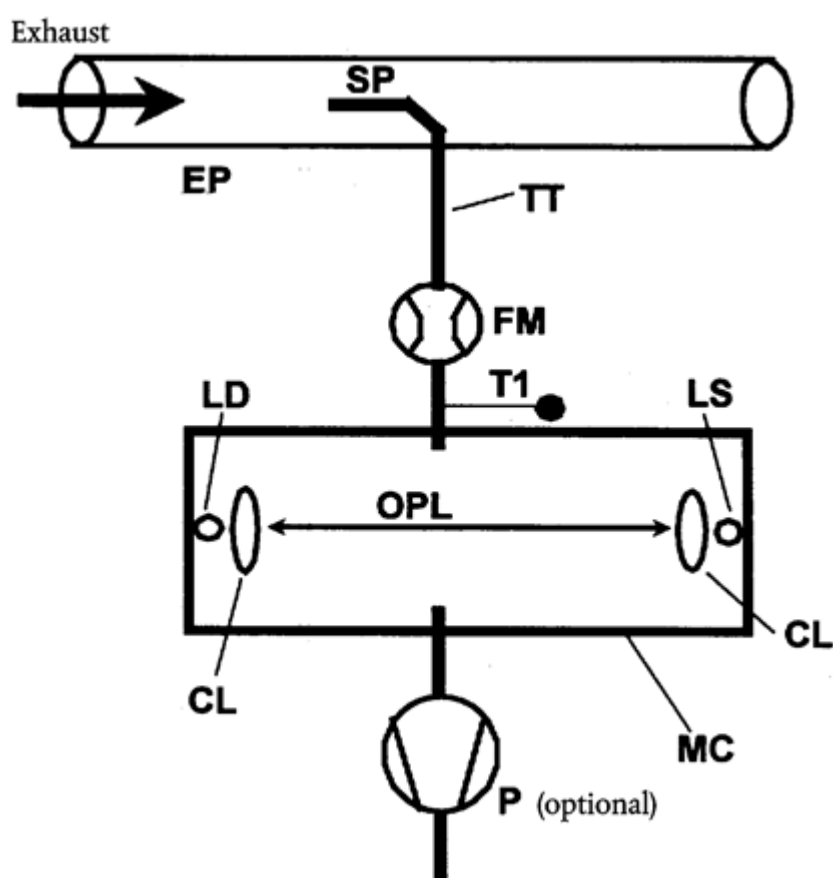

The total amount of raw exhaust gas is mixed in the dilution tunnel DT with the dilution air. The diluted exhaust gas flow rate is measured either with a Positive Displacement Pump PDP or with a Critical Flow Venturi CFV. A heat exchanger HE or electronic flow compensation EFC may be used for proportional particulate sampling and for flow determination. Since particulate mass determination is based on the total diluted exhaust gas flow, the dilution ratio is not required to be calculated.

2.3.1. Components of Figure 20

EP Exhaust pipe

The exhaust pipe length from the exit of the engine exhaust manifold, turbocharger outlet or aftertreatment device to the dilution tunnel shall not exceed 10 m. If the exhaust pipe downstream of the engine exhaust manifold, turbocharger outlet or aftertreatment device

exceeds 4 m in length, then all tubing in excess of 4 m shall be insulated, except for an in-line smokemeter, if used. The radial thickness of the insulation must be at least 25 mm. The thermal conductivity of the insulating material must have a value no greater than 0,1 W/mK measured at 673 K (400 °C). To reduce the thermal inertia of the exhaust pipe a thickness to diameter ratio of 0,015 or less is recommended. The use of flexible sections shall be limited to a length to diameter ratio of 12 or less.

PDP Positive displacement pump

The PDP meters total diluted exhaust flow from the number of the pump revolutions and the pump displacement. The exhaust system backpressure must not be artificially lowered by the PDP or dilution air inlet system. Static exhaust backpressure measured with the PDP system operating shall remain within $\pm 1,5$ kPa of the static pressure measured without connection to the PDP at identical engine speed and load. The gas mixture temperature immediately ahead of the PDP shall be within ± 6 K of the average operating temperature observed during the test, when no flow compensation is used. Flow compensation may only be used if the temperature at the inlet to the PDP does not exceed 323K (50 °C).

CFV Critical Flow Venturi

CFV measures total diluted exhaust flow by maintaining the flow at choked conditions (critical flow). Static exhaust backpressure measured with the CFV system operating shall remain within $\pm 1,5$ kPa of the static pressure measured without connection to the CFV at identical engine speed and load. The gas mixture temperature immediately ahead of the CFV shall be within ± 11 K of the average operating temperature observed during the test, when no flow compensation is used.

HE Heat exchanger (optional, if EFC is used)

The heat exchanger shall be of sufficient capacity to maintain the temperature within the limits required above.

EFC Electronic flow compensation (optional, if HE is used)

If the temperature at the inlet to either the PDP or CFV is not kept within the limits stated above, a flow compensation system is required for continuous measurement of the flow rate and control of the proportional sampling in the particulate system. To that purpose, the continuously measured flow rate signals are used to correct the sample flow rate through the particulate filters of the particulate sampling system (see Section 2.4, Figures 21, 22), accordingly.

DT Dilution tunnel

The dilution tunnel:

- shall be small enough in diameter to cause turbulent flow (Reynolds Number greater than 4 000) and of sufficient length to cause complete mixing of the exhaust and dilution air; a mixing orifice may be used;
- shall be at least 460 mm in diameter with a single dilution system;
- shall be at least 210 mm in diameter with a double dilution system;
- may be insulated.

The engine exhaust shall be directed downstream at the point where it is introduced into the dilution tunnel, and thoroughly mixed.

When using single dilution, a sample from the dilution tunnel is transferred to the particulate sampling system (Section 2.4, Figure 21). The flow capacity of the PDP or CFV must be sufficient to maintain the diluted exhaust at a temperature of less than or equal to 325 K (52 °C) immediately before the primary particulate filter.

When using double dilution, a sample from the dilution tunnel is transferred to the secondary dilution tunnel where it is further diluted, and then passed through the sampling filters (Section

2.4, Figure 22). The flow capacity of the PDP or CFV must be sufficient to maintain the diluted exhaust stream in the DT at a temperature of less than or equal to 464 K (191 °C) at the sampling zone. The secondary dilution system must provide sufficient secondary dilution air to maintain the doubly-diluted exhaust stream at a temperature of less than or equal to 325 K (52 °C) immediately before the primary particulate filter.

DAF Dilution air filter

It is recommended that the dilution air be filtered and charcoal scrubbed to eliminate background hydrocarbons. At the engine manufacturers request the dilution air shall be sampled according to good engineering practice to determine the background particulate levels, which can then be subtracted from the values measured in the diluted exhaust.

PSP Particulate sampling probe

The probe is the leading section of PTT and:

- shall be installed facing upstream at a point where the dilution air and exhaust gas are well mixed, i.e. on the dilution tunnel (DT) centreline approximately 10 tunnel diameters downstream of the point where the exhaust enters the dilution tunnel;
- shall be of 12 mm minimum inside diameter;
- may be heated to no greater than 325 K (52 °C) wall temperature by direct heating or by dilution air pre-heating, provided the air temperature does not exceed 325 K (52 °C) prior to the introduction of the exhaust in the dilution tunnel;
- may be insulated.

2.4. Particulate sampling system

The particulate sampling system is required for collecting the particulates on the particulate filter. In the case of total sampling partial flow dilution, which consists of passing the entire diluted exhaust sample through the filters, dilution (Section 2.2, Figures 14, 18) and sampling system usually form an integral unit. In the case of fractional sampling partial flow dilution or full flow dilution, which consists of passing through the filters only a portion of the diluted exhaust, the dilution (Section 2.2, Figures 11, 12, 13, 15, 16, 17, 19; Section 2.3, Figure 20) and sampling systems usually form different units.

In this Directive, the double dilution system (Figure 22) of a full flow dilution system is considered as a specific modification of a typical particulate sampling system as shown in Figure 21. The double dilution system includes all important parts of the particulate sampling system, like filter holders and sampling pump.

In order to avoid any impact on the control loops, it is recommended that the sample pump be running throughout the complete test procedure. For the single filter method, a bypass system shall be used for passing the sample through the sampling filters at the desired times. Interference of the switching procedure on the control loops must be minimised.

Status: This is the original version (as it was originally adopted).

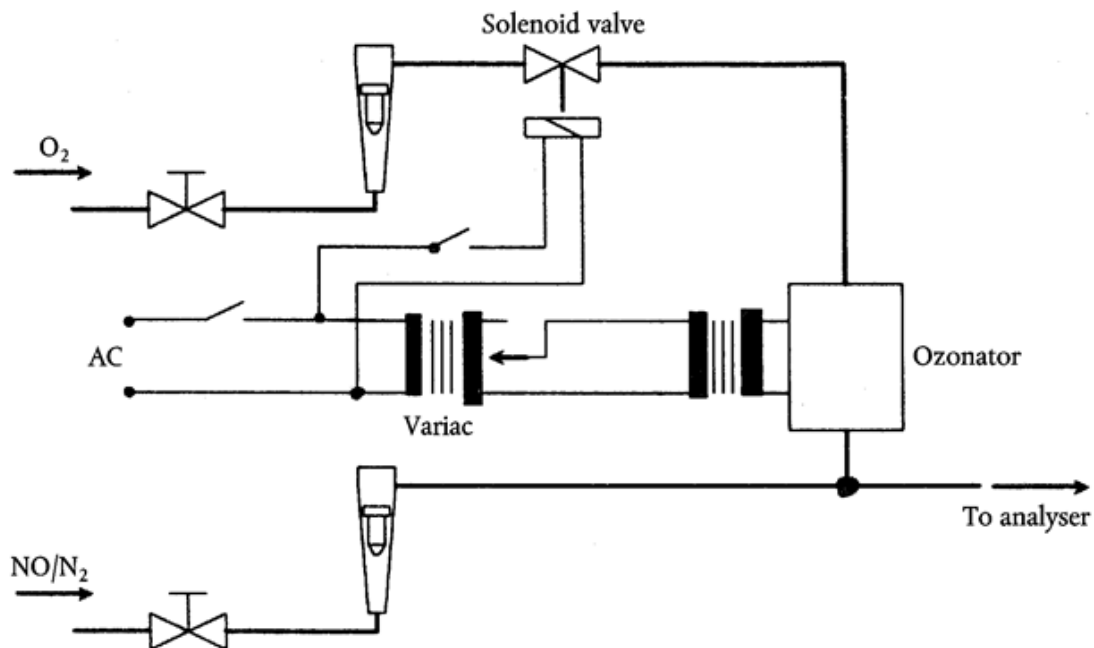

A sample of the diluted exhaust gas is taken from the dilution tunnel DT of a partial flow or full flow dilution system through the particulate sampling probe PSP and the particulate transfer tube PTT by means of the sampling pump P. The sample is passed through the filter holder(s) FH that contain the particulate sampling filters. The sample flow rate is controlled by the flow controller FC3. If electronic flow compensation EFC (see Figure 20) is used, the diluted exhaust gas flow is used as command signal for FC3.

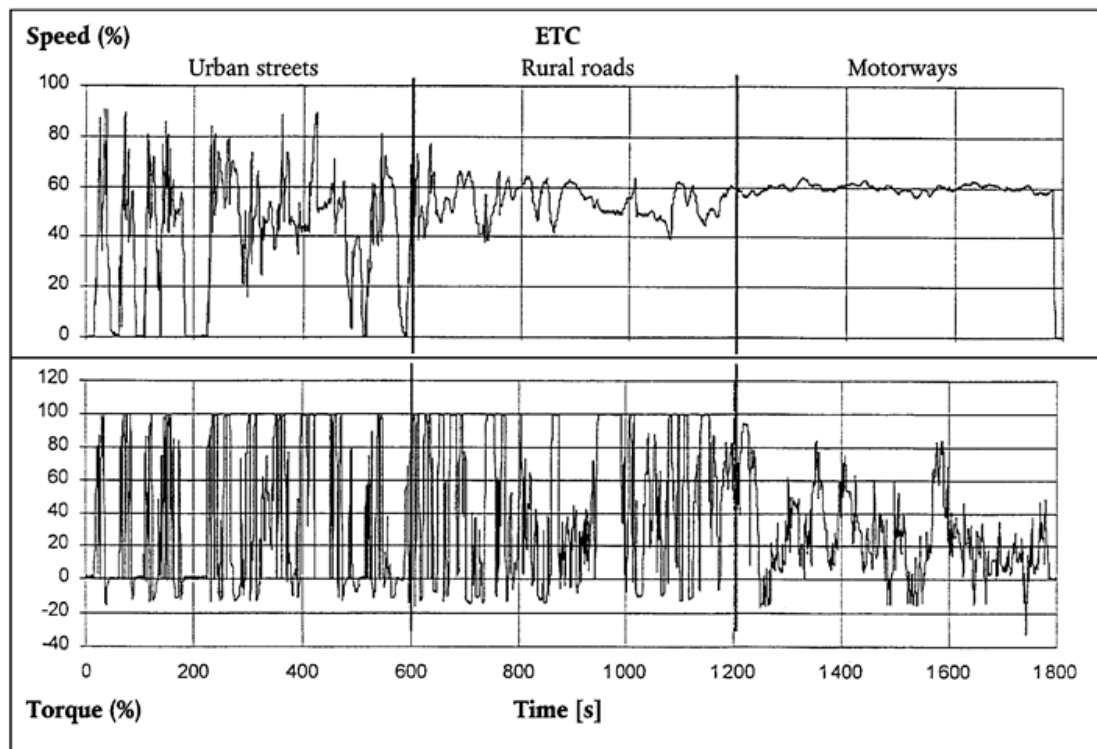

A sample of the diluted exhaust gas is transferred from the dilution tunnel DT of a full flow dilution system through the particulate sampling probe PSP and the particulate transfer tube PTT to the secondary dilution tunnel SDT, where it is diluted once more. The sample is then passed through the filter holder(s) FH that contain the particulate sampling filters. The dilution air flow rate is usually constant whereas the sample flow rate is controlled by the flow controller FC3. If electronic flow compensation EFC (see Figure 20) is used, the total diluted exhaust gas flow is used as command signal for FC3.

2.4.1. Components of Figures 21 and 22

PTT Particulate transfer tube (Figures 21, 22)

The particulate transfer tube must not exceed 1 020 mm in length, and must be minimised in length whenever possible. Where applicable (i.e. for partial flow dilution fractional sampling systems and for full flow dilution systems), the length of the sampling probes (SP, ISP, PSP, respectively, see Sections 2.2 and 2.3) shall be included.

The dimensions are valid for:

- the partial flow dilution fractional sampling type and the full flow single dilution system from the tip of the probe (SP, ISP, PSP, respectively) to the filter holder;
- the partial flow dilution total sampling type from the end of the dilution tunnel to the filter holder;
- the full flow double dilution system from the tip of the probe (PSP) to the secondary dilution tunnel.

The transfer tube:

- may be heated to no greater than 325 K (52 °C) wall temperature by direct heating or by dilution air pre-heating, provided the air temperature does not exceed 325 K (52 °C) prior to the introduction of the exhaust in the dilution tunnel;
- may be insulated.

SDT Secondary dilution tunnel (Figure 22)

The secondary dilution tunnel should have a minimum diameter of 75 mm, and should be of sufficient length so as to provide a residence time of at least 0,25 seconds for the doubly-diluted sample. The primary filter holder FH shall be located within 300 mm of the exit of the SDT.

The secondary dilution tunnel:

- may be heated to no greater than 325 K (52 °C) wall temperature by direct heating or by dilution air pre-heating, provided the air temperature does not exceed 325 K (52 °C) prior to the introduction of the exhaust in the dilution tunnel;
- may be insulated.

FH Filter holder(s) (Figures 21, 22)

For primary and back-up filters one filter housing or separate filter housings may be used. The requirements of Annex III, Appendix 4, Section 4.1.3 shall be met.

The filter holder(s):

- may be heated to no greater than 325 K (52 °C) wall temperature by direct heating or by dilution air pre-heating, provided the air temperature does not exceed 325 K (52 °C) prior to the introduction of the exhaust in the dilution tunnel;
- may be insulated.

P Sampling pump (Figures 21, 22)

The particulate sampling pump shall be located sufficiently distant from the tunnel so that the inlet gas temperature is maintained constant (± 3 K), if flow correction by FC3 is not used.

DP Dilution air pump (Figure 22)

The dilution air pump shall be located so that the secondary dilution air is supplied at a temperature of $298\text{ K} \pm 5\text{ K}$ ($25\text{ °C} \pm 5\text{ °C}$), if the dilution air is not preheated.

FC3 Flow controller (Figures 21, 22)

A flow controller shall be used to compensate the particulate sample flow rate for temperature and backpressure variations in the sample path, if no other means are available. The flow controller is required if electronic flow compensation EFC (see Figure 20) is used.

FM3 Flow measurement device (Figures 21, 22)

The gas meter or flow instrumentation for the particulate sample flow shall be located sufficiently distant from the sampling pump P so that the inlet gas temperature remains constant ($\pm 3\text{ K}$), if flow correction by FC3 is not used.

FM4 Flow measurement device (Figure 22)

The gas meter or flow instrumentation for the dilution air flow shall be located so that the inlet gas temperature remains at $298\text{ K} \pm 5\text{ K}$ ($25\text{ °C} \pm 5\text{ °C}$).

BV Ball valve (optional)

The ball valve shall have an inside diameter not less than the inside diameter of the particulate transfer tube PTT, and a switching time of less than 0,5 seconds.

Note: If the ambient temperature in the vicinity of PSP, PTT, SDT, and FH is below 293 K (20 °C), precautions should be taken to avoid particle losses onto the cool wall of these parts. Therefore, heating and/or insulating these parts within the limits given in the respective descriptions is recommended. It is also recommended that the filter face temperature during sampling be not below 293 K (20 °C).

At high engine loads, the above parts may be cooled by a non-aggressive means such as a circulating fan, as long as the temperature of the cooling medium is not below 293 K (20 °C).

3. DETERMINATION OF SMOKE

3.1. Introduction

Sections 3.2 and 3.3 and Figures 23 and 24 contain detailed descriptions of the recommended opacimeter systems. Since various configurations can produce equivalent results, exact conformance with Figures 23 and 24 is not required. Additional components such as instruments, valves, solenoids, pumps, and switches may be used to provide additional information and coordinate the functions of the component systems. Other components which are not needed to maintain the accuracy on some systems, may be excluded if their exclusion is based upon good engineering judgement.

The principle of measurement is that light is transmitted through a specific length of the smoke to be measured and that proportion of the incident light which reaches a receiver is used to assess the light obscuration properties of the medium. The smoke measurement depends upon the design of the apparatus, and may be done in the exhaust pipe (full flow in-line opacimeter), at the end of the exhaust pipe (full flow end-of-line opacimeter) or by taking a sample from the exhaust pipe (partial flow opacimeter). For the determination of the light absorption coefficient from the opacity signal, the optical path length of the instrument shall be supplied by the instrument manufacturer.

3.2. Full flow opacimeter

Two general types of full flow opacimeters may be used (Figure 23). With the in-line opacimeter, the opacity of the full exhaust plume within the exhaust pipe is measured. With this type of opacimeter, the effective optical path length is a function of the opacimeter design.

With the end-of-line opacimeter, the opacity of the full exhaust plume is measured as it exits the exhaust pipe. With this type of opacimeter, the effective optical path length is a function of the exhaust pipe design and the distance between the end of the exhaust pipe and the opacimeter.

Status: This is the original version (as it was originally adopted).

INFORMATION DOCUMENT No ...

IN ACCORDANCE WITH ANNEX I TO COUNCIL DIRECTIVE 70/156/EEC RELATING TO EC TYPE APPROVAL

and referring to measures to be taken against the emission of gaseous and particulate pollutants from compression-ignition engines for use in vehicles, and the emission of gaseous pollutants from positive-ignition engines fuelled with natural gas or liquefied petroleum gas for use in vehicles

(Directive 2005/55/EC)

Vehicle type/parent engine/engine type ⁽¹⁾

- 0. GENERAL
- 0.1. Make (name of undertaking):
- 0.2. Type and commercial description (mention any variants):
- 0.3. Means and location of identification of type, if marked on the vehicle:
- 0.4. Category of vehicle (if applicable):
- 0.5. Category of engine: diesel/NG fuelled/LPG fuelled/ethanol fuelled ⁽¹⁾
- 0.6. Name and address of manufacturer:
- 0.7. Location of statutory plates and inscriptions and method of affixing:
- 0.8. In the case of components and separate technical units, location and method of affixing of the EC approval mark:
- 0.9. Address(es) of assembly plant(s):

Attachments

- 1. Essential characteristics of the (parent) engine and information concerning the conduct of test.
- 2. Essential characteristics of the engine family.
- 3. Essential characteristics of the engine types within the family.
- 4. Characteristics of the engine-related vehicle parts (if applicable).
- 5. Photographs and/or drawings of the parent engine type and, if applicable, of the engine compartment.
- 6. List further attachments if any.

Date, File

⁽¹⁾ Delete as appropriate.

3.2.1. Components of Figure 23

EP Exhaust Pipe

With an in-line opacimeter, there shall be no change in the exhaust pipe diameter within 3 exhaust pipe diameters before or after the measuring zone. If the diameter of the measuring zone is greater than the diameter of the exhaust pipe, a pipe gradually convergent before the measuring zone is recommended.

With an end-of-line opacimeter, the terminal 0,6 m of the exhaust pipe shall be of circular cross section and be free from elbows and bends. The end of the exhaust pipe shall be cut off squarely. The opacimeter shall be mounted centrally to the plume within 25 ± 5 mm of the end of the exhaust pipe.

OPL Optical Path Length

The length of the smoke obscured optical path between the opacimeter light source and the receiver, corrected as necessary for non-uniformity due to density gradients and fringe effect. The optical path length shall be submitted by the instrument manufacturer taking into account any measures against sooting (e.g. purge air). If the optical path length is not available, it shall be determined in accordance with ISO IDS 11614, Section 11.6.5. For the correct determination of the optical path length, a minimum exhaust gas velocity of 20 m/s is required.

LS Light source

The light source shall be an incandescent lamp with a colour temperature in the range of 2 800 to 3 250 K or a green light emitting diode (LED) with a spectral peak between 550 and 570 nm. The light source shall be protected against sooting by means that do not influence the optical path length beyond the manufacturers specifications.

LD Light detector

The detector shall be a photocell or a photodiode (with a filter, if necessary). In the case of an incandescent light source, the receiver shall have a peak spectral response similar to the photopic curve of the human eye (maximum response) in the range of 550 to 570 nm, to less than 4 % of that maximum response below 430 nm and above 680 nm. The light detector shall be protected against sooting by means that do not influence the optical path length beyond the manufacturers specifications.

CL Collimating lens

The light output shall be collimated to a beam with a maximum diameter of 30 mm. The rays of the light beam shall be parallel within a tolerance of 3° of the optical axis.

T1 Temperature sensor (optional)

The exhaust gas temperature may be monitored over the test.

3.3. Partial flow opacimeter

With the partial flow opacimeter (Figure 24), a representative exhaust sample is taken from the exhaust pipe and passed through a transfer line to the measuring chamber. With this type of opacimeter, the effective optical path length is a function of the opacimeter design. The response times referred to in the following section apply to the minimum flow rate of the opacimeter, as specified by the instrument manufacturer.

Status: This is the original version (as it was originally adopted).

1. Intake system depression at rated engine speed and at 100 % load: kPa
2. Exhaust system back pressure at rated engine speed and at 100 % load: kPa
3. Volume of exhaust system: cm³
4. Power absorbed by the auxiliaries needed for operating the engine as specified in and under the operation conditions of Directive 80/1269/EEC, Annex I, Section 5.1.1.

Equipment	Power absorbed (kW) at various engine speeds						
	Idle	Low speed	High speed	Speed A ⁽¹⁾	Speed B ⁽¹⁾	Speed C ⁽¹⁾	Ref. speed ⁽²⁾
P(a) Auxiliaries needed for operating the engine (to be subtracted from measured engine power) See Appendix 1, Section 6.1.							

⁽¹⁾ ESC test.
⁽²⁾ ETC test only.

3.3.1. Components of Figure 24

EP Exhaust pipe

The exhaust pipe shall be a straight pipe of at least 6 pipe diameters upstream and 3 pipe diameters downstream of the tip of the probe.

SP Sampling probe

The sampling probe shall be an open tube facing upstream on or about the exhaust pipe centreline. The clearance with the wall of the tailpipe shall be at least 5 mm. The probe diameter shall ensure a representative sampling and a sufficient flow through the opacimeter.

TT Transfer tube

The transfer tube shall:

- Be as short as possible and ensure an exhaust gas temperature of 373 ± 30 K ($100 \text{ °C} \pm 30 \text{ °C}$) at the entrance to the measuring chamber.
- Have a wall temperature sufficiently above the dew point of the exhaust gas to prevent condensation.
- Be equal to the diameter of the sampling probe over the entire length.
- Have a response time of less than 0,05 s at minimum instrument flow, as determined according to Annex III, Appendix 4, Section 5.2.4.
- Have no significant effect on the smoke peak.

FM Flow measurement device

Flow instrumentation to detect the correct flow into the measuring chamber. The minimum and maximum flow rates shall be specified by the instrument manufacturer, and shall be such that the response time requirement of TT and the optical path length specifications are met. The flow measurement device may be close to the sampling pump, P, if used.

MC Measuring chamber

The measuring chamber shall have a non-reflective internal surface, or equivalent optical environment. The impingement of stray light on the detector due to internal reflections of diffusion effects shall be reduced to a minimum.

The pressure of the gas in the measuring chamber shall not differ from the atmospheric pressure by more than 0,75 kPa. Where this is not possible by design, the opacimeter reading shall be converted to atmospheric pressure.

The wall temperature of the measuring chamber shall be set to within ± 5 K between 343 K (70 °C) and 373 K (100 °C), but in any case sufficiently above the dew point of the exhaust gas to prevent condensation. The measuring chamber shall be equipped with appropriate devices for measuring the temperature.

OPL Optical path length

The length of the smoke obscured optical path between the opacimeter light source and the receiver, corrected as necessary for non-uniformity due to density gradients and fringe effect. The optical path length shall be submitted by the instrument manufacturer taking into account any measures against sooting (e.g. purge air). If the optical path length is not available, it shall be determined in accordance with ISO IDS 11614, Section 11.6.5.

LS Light source

The light source shall be an incandescent lamp with a colour temperature in the range of 2 800 to 3 250 K or a green light emitting diode (LED) with a spectral peak between 550 and 570 nm. The light source shall be protected against sooting by means that do not influence the optical path length beyond the manufacturers specifications.

LD Light detector

The detector shall be a photocell or a photodiode (with a filter, if necessary). In the case of an incandescent light source, the receiver shall have a peak spectral response similar to the photopic curve of the human eye (maximum response) in the range of 550 to 570 nm, to less than 4 % of that maximum response below 430 nm and above 680 nm. The light detector shall be protected against sooting by means that do not influence the optical path length beyond the manufacturers specifications.

CL Collimating lens

The light output shall be collimated to a beam with a maximum diameter of 30 mm. The rays of the light beam shall be parallel within a tolerance of 3° of the optical axis.

T1 Temperature sensor

To monitor the exhaust gas temperature at the entrance to the measuring chamber.

P Sampling pump (optional)

A sampling pump downstream of the measuring chamber may be used to transfer the sample gas through the measuring chamber.