

Directive 2005/55/EC of the European Parliament and of the Council of 28 September 2005 on the approximation of the laws of the Member States relating to the measures to be taken against the emission of gaseous and particulate pollutants from compression-ignition engines for use in vehicles, and the emission of gaseous pollutants from positive-ignition engines fuelled with natural gas or liquefied petroleum gas for use in vehicles (Text with EEA relevance) (repealed)

DIRECTIVE 2005/55/EC OF THE EUROPEAN
PARLIAMENT AND OF THE COUNCIL

of 28 September 2005

on the approximation of the laws of the Member States relating to the measures to be taken against the emission of gaseous and particulate pollutants from compression-ignition engines for use in vehicles, and the emission of gaseous pollutants from positive-ignition engines fuelled with natural gas or liquefied petroleum gas for use in vehicles

(Text with EEA relevance) (repealed)

THE EUROPEAN PARLIAMENT AND THE COUNCIL OF THE EUROPEAN UNION,

Having regard to the Treaty establishing the European Community, and in particular Article 95 thereof,

Having regard to the proposal from the Commission,

Having regard to the opinion of the European Economic and Social Committee⁽¹⁾,

Acting in accordance with the procedure laid down in Article 251 of the Treaty⁽²⁾,

Whereas:

- (1) Council Directive 88/77/EEC of 3 December 1987 on the approximation of the laws of the Member States relating to the measures to be taken against the emission of gaseous and particulate pollutants from compression ignition engines for use in vehicles, and the emission of gaseous pollutants from positive ignition engines fuelled with natural gas or liquefied petroleum gas for use in vehicles⁽³⁾ is one of the separate Directives under the type-approval procedure laid down by Council Directive 70/156/EEC of 6 February 1970 on the approximation of the laws of the Member States relating to the type-approval of motor vehicles and their trailers⁽⁴⁾. Directive 88/77/EEC has been substantially amended several times to introduce successively more stringent pollutant emission limits. Since further amendments are to be made, it should be recast in the interests of clarity.
- (2) Council Directive 91/542/EEC⁽⁵⁾ amending Directive 88/77/EEC, Directive 1999/96/EC of the European Parliament and of the Council of 13 December 1999 on the approximation of the laws of the Member States relating to measures to be taken against the emission of gaseous and particulate pollutants from compression ignition engines for use in vehicles, and the emission of gaseous pollutants from positive ignition engines

fuelled with natural gas or liquefied petroleum gas for use in vehicles and amending Council Directive 88/77/EEC⁽⁶⁾, and Commission Directive 2001/27/EC⁽⁷⁾ adapting to technical progress Council Directive 88/77/EEC have introduced provisions which, while being autonomous, are closely linked to the scheme established under Directive 88/77/EEC. Those autonomous provisions should be fully integrated into the recast of Directive 88/77/EEC in the interests of clarity and legal certainty.

- (3) It is necessary that all the Member States adopt the same requirements, in order, in particular, to permit the implementation, for each vehicle type, of the EC type-approval system which is the subject of Directive 70/156/EEC.
- (4) The Commission's programme on air quality, road transport emissions, fuels and emission abatement technologies, hereinafter 'the first Auto-Oil programme', showed that further reductions in pollutant emissions from heavy-duty vehicles were necessary with a view to achieving future air quality standards.
- (5) Reductions in emission limits applicable from the year 2000, corresponding to abatements of 30 % in emissions of carbon monoxide, total hydrocarbons, oxides of nitrogen and particulate matter were identified by the first Auto-Oil programme as key measures for the achievement of medium-term air quality. A reduction of 30 % in exhaust smoke opacity should additionally contribute to the reduction of particulate matter. Additional reductions in emission limits applicable from the year 2005, corresponding to additional abatements of 30 % in carbon monoxide, total hydrocarbons and oxides of nitrogen and 80 % in particulate matter should greatly contribute to air quality improvement in the medium to longer term. The additional limit for oxides of nitrogen applicable in the year 2008 should result in a further 43 % reduction in the emission limit for this pollutant.
- (6) Type-approval tests for gaseous and particulate pollutants and smoke opacity are applicable to allow for a more representative evaluation of the emissions performance of engines under test conditions that more closely resemble those encountered by vehicles in-service. Since 2000 conventional compression-ignition engines and those compression-ignition engines fitted with certain types of emission control equipment have been tested over a steady-state test cycle and using a new load response test for smoke opacity. Compression-ignition engines fitted with advanced emission control systems have, in addition, been tested over a new transient test cycle. From 2005, all compression-ignition engines should be tested on all those test cycles. Gas fuelled engines are only tested on the new transient test cycle.
- (7) Under all randomly selected load conditions within a defined operating range, the limit values may not be exceeded by more than an appropriate percentage.
- (8) In laying down new standards and test procedures, it is necessary to take account of the impact on air quality of future traffic growth in the Community. The work undertaken by the Commission in this sphere has shown that the motor industry in the Community has made great strides in the perfection of the technology allowing a considerable reduction in emissions of gaseous and particulate pollutants. However, it is still necessary to press for further improvements in emission limits and other technical requirements in the interests of environmental protection and public health. In particular, the results of

ongoing research into the characteristics of ultra-fine particulates should be taken into account in any future measures.

- (9) It is necessary that further improvements be made to the quality of motor fuels to enable the efficient and durable performance of emission control systems in service.
- (10) New provisions for on-board diagnostics (OBD) should be introduced from 2005 with a view to facilitating the immediate detection of the deterioration or failure of engine emission control equipment. This should enhance diagnostic and repair capability, significantly improving the sustainable emission performance of in-service heavy-duty vehicles. Since, on the worldwide stage, OBD for heavy-duty diesel engines is in its infancy, it should be introduced in the Community in two stages to allow for system development so that the OBD system does not give false indications. In order to assist the Member States in ensuring that the owners and operators of heavy-duty vehicles meet their obligation to repair faults indicated by the OBD system, the distance covered or the time that has elapsed after a fault has been indicated to the driver should be recorded.
- (11) Compression-ignition engines are inherently durable and have demonstrated that, with proper and effective maintenance, they can retain a high level of emissions performance over the significantly high distances travelled by heavy-duty vehicles in the course of commercial operations. However, future emission standards will push the introduction of emission control systems downstream of the engine, such as deNO_x systems, diesel particulate filters and systems that are a combination of both and, perhaps, other systems yet to be defined. It is therefore necessary to establish a useful life requirement on which to base procedures for ensuring the compliance of an engine's emission control system throughout that reference period. In establishing such a requirement, due account should be taken of the considerable distances covered by heavy-duty vehicles, of the need to incorporate appropriate and timely maintenance and of the possibility of type-approving category N₁ vehicles in accordance with either this Directive or Council Directive 70/220/EEC of 20 March 1970 on the approximation of the laws of the Member States on measures to be taken against air pollution by emissions from motor vehicles⁽⁸⁾.
- (12) Member States should be allowed, by means of tax incentives, to expedite the placing on the market of vehicles that satisfy the requirements adopted at Community level, provided that such incentives comply with the provisions of the Treaty and satisfy certain conditions intended to prevent distortion of the internal market. This Directive does not affect the right of the Member States to include emissions of pollutants and other substances in the basis for calculating road traffic taxes on motor vehicles.
- (13) Since some of those tax incentives are State aids under Article 87(1) of the Treaty, they would have to be notified to the Commission under Article 88(3) of the Treaty for evaluation in accordance with the relevant criteria of compatibility. The notification of such measures in accordance with this Directive should be without prejudice to the obligation to notify under Article 88(3) of the Treaty.
- (14) With the aim of simplifying and accelerating the procedure, the Commission should be entrusted with the task of adopting measures implementing the fundamental provisions

laid down in this Directive as well as the measures for adapting the annexes of this Directive to scientific and technical progress.

- (15) The measures necessary for the implementation of this Directive and its adaptation to scientific and technical progress should be adopted in accordance with Council Decision 1999/468/EC of 28 June 1999 laying down the procedures for the exercise of implementing powers conferred on the Commission⁽⁹⁾.
- (16) The Commission should keep under review the need to introduce emission limits for pollutants which are as yet unregulated and which arise as a consequence of the wider use of new alternative fuels and new exhaust emission control systems.
- (17) The Commission should submit proposals it may deem appropriate for a further stage for limit values for NO_x and particulate emissions as soon as possible.
- (18) Since the objective of this Directive, namely the realisation of the internal market through the introduction of common technical requirements concerning gaseous and particulate emissions for all types of vehicles, cannot be sufficiently achieved by the Member States and can therefore, by reason of the scale of the action, be better achieved at Community level, the Community may adopt measures, in accordance with the principle of subsidiarity, as set out in Article 5 of the Treaty. In accordance with the principle of proportionality, as set out in that Article, this Directive does not go beyond what is necessary in order to achieve this objective.
- (19) The obligation to transpose this Directive into national law should be confined to those provisions which represent a substantive change as compared with the earlier Directives. The obligation to transpose the provisions which are unchanged arises under the earlier Directives.
- (20) This Directive should be without prejudice to the obligations of the Member States relating to the time limits for transposition into national law and application of the Directives set out in Annex IX, Part B.

HAVE ADOPTED THIS DIRECTIVE:

Article 1

Definitions

For the purposes of this Directive the following definitions shall apply:

- (a) 'vehicle' means any vehicle as defined in Article 2 of Directive 70/156/EEC and propelled by a compression-ignition or gas engine, with the exception of vehicles of category M₁ with a technically permissible maximum laden mass less than or equal to 3,5 tonnes;
- (b) 'compression-ignition or gas engine' means the motive propulsion source of a vehicle for which type-approval as a separate technical unit, as defined in Article 2 of Directive 70/156/EEC, may be granted;

- (c) ‘enhanced environment-friendly vehicle (EEV)’ means a vehicle propelled by an engine which complies with the permissive emission limit values set out in row C of the tables in Section 6.2.1 of Annex I.

Article 2

Obligations of the Member States

1 For types of compression-ignition or gas engines and types of vehicle propelled by compression-ignition or gas engines, where the requirements set out in Annexes I to VIII are not met and in particular where the emissions of gaseous and particulate pollutants and opacity of smoke from the engine do not comply with the limit values set out in row A of the tables in Section 6.2.1 of Annex I, Member States:

- a shall refuse to grant EC type-approval pursuant to Article 4(1) of Directive 70/156/EEC; and
- b shall refuse national type-approval.

2 Except in the case of vehicles and engines intended for export to third countries or replacement engines for in-service vehicles, Member States shall, where the requirements set out in Annexes I to VIII are not met and in particular where the emissions of gaseous and particulate pollutants and opacity of smoke from the engine do not comply with the limit values set out in row A of the tables in Section 6.2.1 of Annex I:

- a consider certificates of conformity which accompany new vehicles or new engines pursuant to Directive 70/156/EEC as no longer valid for the purposes of Article 7(1) of that Directive; and
- b prohibit the registration, sale, entry into service or use of new vehicles propelled by a compression-ignition or gas engine and the sale or use of new compression-ignition or gas engines.

3 Without prejudice to paragraphs 1 and 2, with effect from 1 October 2003 and except in the case of vehicles and engines intended for export to third countries or replacement engines for in-service vehicles, Member States shall, for types of gas engines and types of vehicles propelled by a gas engine which do not comply with the requirements set out in Annexes I to VIII:

- a consider certificates of conformity which accompany new vehicles or new engines pursuant to Directive 70/156/EEC as no longer valid for the purposes of Article 7(1) of that Directive; and
- b prohibit the registration, sale, entry into service or use of new vehicles and the sale or use of new engines.

4 If the requirements set out in Annexes I to VIII and in Articles 3 and 4 are satisfied, in particular where the emissions of gaseous and particulate pollutants and opacity of smoke from the engine comply with the limit values set out in row B1 or row B2 or with the permissive limit values set out in row C of the tables in Section 6.2.1 of Annex I, no Member State may, on grounds relating to the gaseous and particulate pollutants and opacity of smoke emissions from an engine:

- a refuse to grant EC type-approval pursuant to Article 4(1) of Directive 70/156/EEC or to grant national type-approval for a type of vehicle propelled by a compression-ignition or gas engine;
- b prohibit the registration, sale, entry into service or use of new vehicles propelled by a compression-ignition or gas engine;
- c refuse to grant EC type-approval for a type of compression-ignition or gas engine;

- d prohibit the sale or use of new compression-ignition or gas engines.

5 With effect from 1 October 2005, for types of compression-ignition or gas engines and types of vehicle propelled by compression-ignition or gas engines which do not meet the requirements set out in Annexes I to VIII and in Articles 3 and 4 and in particular where the emissions of gaseous and particulate pollutants and opacity of smoke from the engine do not comply with the limit values set out in row B1 of the tables in Section 6.2.1 of Annex I, Member States:

- a shall refuse to grant EC type-approval pursuant to Article 4(1) of Directive 70/156/EEC; and
- b shall refuse national type-approval.

6 With effect from 1 October 2006 and except in the case of vehicles and engines intended for export to third countries or replacement engines for in-service vehicles, Member States shall, where the requirements set out in Annexes I to VIII and in Articles 3 and 4 are not met and in particular where the emissions of gaseous and particulate pollutants and opacity of smoke from the engine do not comply with the limit values set out in row B1 of the tables in Section 6.2.1 of Annex I:

- a consider certificates of conformity which accompany new vehicles or new engines pursuant to Directive 70/156/EEC as no longer valid for the purposes of Article 7(1) of that Directive; and
- b prohibit the registration, sale, entry into service or use of new vehicles propelled by a compression-ignition or gas engine and the sale or use of new compression-ignition or gas engines.

7 With effect from 1 October 2008, for types of compression-ignition or gas engines and types of vehicle propelled by compression-ignition or gas engines which do not meet the requirements set out in Annexes I to VIII and in Articles 3 and 4 and in particular where the emissions of gaseous and particulate pollutants and opacity of smoke from the engine do not comply with the limit values set out in row B2 of the tables in Section 6.2.1 of Annex I, Member States:

- a shall refuse to grant EC type-approval pursuant to Article 4(1) of Directive 70/156/EEC; and
- b shall refuse national type-approval.

8 With effect from 1 October 2009 and except in the case of vehicles and engines intended for export to third countries or replacement engines for in-service vehicles, Member States shall, where the requirements set out in Annexes I to VIII and in Articles 3 and 4 are not met and in particular where the emissions of gaseous and particulate pollutants and opacity of smoke from the engine do not comply with the limit values set out in row B2 of the tables in Section 6.2.1 of Annex I:

- a consider certificates of conformity which accompany new vehicles or new engines pursuant to Directive 70/156/EEC as no longer valid for the purposes of Article 7(1) of that Directive; and
- b prohibit the registration, sale, entry into service or use of new vehicles propelled by a compression-ignition or gas engine and the sale or use of new compression-ignition or gas engines.

9 In accordance with paragraph 4 an engine that satisfies the requirements set out in Annexes I to VIII, and, in particular, complies with the limit values set out in row C of the tables in Section 6.2.1 of Annex I shall be considered as complying with the requirements set out in paragraphs 1, 2 and 3.

In accordance with paragraph 4 an engine that satisfies the requirements set out in Annexes I to VIII and in Articles 3 and 4 and, in particular, complies with the limit values set out in row C of the tables in Section 6.2.1 of Annex I shall be considered as complying with the requirements set out in paragraphs 1 to 3 and 5 to 8.

10 For compression-ignition or gas engines that must comply with the limit values set out in Section 6.2.1 of Annex I under the type-approval system, the following shall apply:

under all randomly selected load conditions, belonging to a definite control area and with the exception of specified engine operating conditions which are not subject to such a provision, the emissions sampled during a time duration as small as 30 seconds shall not exceed by more than 100 % the limit values in rows B2 and C of the tables in Section 6.2.1 of Annex I. The control area to which the percentage not to be exceeded shall apply, the excluded engine operating conditions and other appropriate conditions shall be defined in accordance with the procedure referred to in Article 7(1).

Article 3

Durability of emission control systems

1 From 1 October 2005 for new type-approvals and from 1 October 2006 for all type-approvals, the manufacturer shall demonstrate that a compression-ignition or gas engine type-approved by reference to the limit values set out in row B1 or row B2 or row C of the tables in Section 6.2.1 of Annex I will comply with those limit values for a useful life of:

- a 100 000 km or five years, whichever is the sooner, in the case of engines to be fitted to vehicles of category N₁ and M₂;
- b 200 000 km or six years, whichever is the sooner, in the case of engines to be fitted to vehicles of category N₂, N₃ with a maximum technically permissible mass not exceeding 16 tonnes and M₃ Class I, Class II and Class A, and Class B with a maximum technically permissible mass not exceeding 7,5 tonnes;
- c 500 000 km or seven years, whichever is the sooner, in the case of engines to be fitted to vehicles of category N₃ with a maximum technically permissible mass exceeding 16 tonnes and M₃, Class III and Class B with a maximum technically permissible mass exceeding 7,5 tonnes.

From 1 October 2005, for new types, and from 1 October 2006, for all types, type-approvals granted to vehicles shall also require confirmation of the correct operation of the emission control devices during the normal life of the vehicle under normal conditions of use (conformity of in-service vehicles properly maintained and used).

2 The measures for the implementation of paragraph 1 shall be adopted by 28 December 2005 at the latest.

Article 4

On-board diagnostic systems

1 From 1 October 2005 for new type-approvals of vehicles and from 1 October 2006 for all type-approvals, a compression-ignition engine type-approved by reference to the emission limit values set out in row B1 or row C of the tables in Section 6.2.1 of Annex I or a vehicle propelled by such an engine shall be fitted with an on-board diagnostic (OBD) system that signals the presence of a fault to the driver if the OBD threshold limits set out in row B1 or row C of the table in paragraph 3 are exceeded.

In the case of exhaust after-treatment systems, the OBD system may monitor for major functional failure any of the following:

- a a catalyst, where fitted as a separate unit, whether or not it is part of a deNO_x system or a diesel particulate filter;
- b a deNO_x system, where fitted;
- c a diesel particulate filter, where fitted;
- d a combined deNO_x-diesel particulate filter system.

2 From 1 October 2008 for new type-approvals and from 1 October 2009 for all type-approvals, a compression-ignition or a gas engine type-approved by reference to the emission limit values set out in row B2 or row C of the tables in Section 6.2.1 of Annex I, or a vehicle propelled by such an engine shall be fitted with an OBD system that signals the presence of a fault to the driver if the OBD threshold limits set out in row B2 or row C of the table in paragraph 3 are exceeded.

The OBD system shall also include an interface between the engine electronic control unit (EECU) and any other engine or vehicle electrical or electronic systems that provide an input to or receive an output from the EECU and which affect the correct functioning of the emission control system, such as the interface between the EECU and a transmission electronic control unit.

3 The OBD threshold limits shall be as follows:

Row	Compression-ignition engines	
	Mass of oxides of nitrogen(NO _x) g/kWh	Mass of particulate(PT) g/kWh
B1 (2005)	7,0	0,1
B2 (2008)	7,0	0,1
C (EEV)	7,0	0,1

4 Full and uniform access to OBD information must be provided for the purposes of testing, diagnosis, servicing and repair in keeping with the relevant provisions of Directive 70/220/EEC and provisions regarding replacement components ensuring compatibility with OBD systems.

5 The measures for the implementation of paragraphs 1, 2 and 3 shall be adopted by 28 December 2005 at the latest.

Article 5

Emission control systems using consumable reagents

In defining the measures necessary to implement Article 4, as provided for by Article 7(1), the Commission shall, if appropriate, include technical measures to minimise the risk of emission control systems using consumable reagents being inadequately maintained in service. In addition, and if appropriate, measures shall be included to ensure that emissions of ammonia due to the use of consumable reagents are minimised.

Article 6

Tax incentives

1 Member States may make provision for tax incentives only in respect of vehicles which comply with this Directive. Such incentives shall comply with the provisions of the Treaty, as well as with either paragraph 2 or paragraph 3 of this Article.

2 The incentives shall apply to all new vehicles offered for sale on the market of a Member State which comply in advance with the limit values set out in row B1 or B2 of the tables in Section 6.2.1 of Annex I.

They shall be terminated with effect from the mandatory application of the limit values in row B1, as laid down in Article 2(6), or from the mandatory application of the limit values in row B2, as laid down in Article 2(8).

3 The incentives shall apply to all new vehicles offered for sale on the market of a Member State which comply with the permissive limit values set out in row C of the tables in Section 6.2.1 of Annex I.

4 In addition to the conditions referred to in paragraph 1, for each type of vehicle, the incentives shall not exceed the additional cost of the technical solutions introduced to ensure compliance with the limit values set out in row B1 or row B2 or with the permissive limit values set out in row C of the tables in Section 6.2.1 of Annex I, and of their installation on the vehicle.

5 Member States shall inform the Commission in sufficient time of plans to institute or change the tax incentives referred to in this Article, so that it can submit its observations.

Article 7

Implementation measures and amendments

1 The measures necessary for the implementation of Articles 2(10), 3 and 4 of this Directive shall be adopted by the Commission, assisted by the Committee established by Article 13(1) of Directive 70/156/EEC, in accordance with the procedure referred to in Article 13(3) of that Directive.

2 Amendments to this Directive which are necessary to adapt it to scientific and technical progress shall be adopted by the Commission, assisted by the committee established by Article 13(1) of Directive 70/156/EEC, in accordance with the procedure referred to in Article 13(3) of that Directive.

Article 8

Review and reports

1 The Commission shall review the need to introduce new emission limits applicable to heavy-duty vehicles and engines in respect of pollutants that are as yet unregulated. The review shall be based on the wider market introduction of new alternative fuels and on the introduction of new additive-enabled exhaust emission control systems to meet future standards laid down in this Directive. Where appropriate, the Commission shall submit a proposal to the European Parliament and the Council.

2 The Commission should submit to the European Parliament and the Council legislative proposals on further limits on NO_x and particulate emissions for heavy-duty vehicles.

If appropriate, it shall investigate whether setting an additional limit for particulate levels and size is necessary, and, if so, include it in the proposals.

3 The Commission shall report to the European Parliament and to the Council on the progress in negotiations for a worldwide harmonised duty cycle (WHDC).

4 The Commission shall submit a report to the European Parliament and to the Council on requirements for the operation of an on-board measurement (OBM) system. On the basis of that report, the Commission shall, where appropriate, submit a proposal for measures to include the technical specifications and corresponding annexes in order to provide for the type-approval of OBM systems which ensure at least equivalent levels of monitoring to OBD systems and which are compatible therewith.

Article 9

Transposition

1 Member States shall adopt and publish, before 9 November 2006 at the latest, the laws, regulations and administrative provisions necessary to comply with this Directive. If the adoption of the implementing measures referred to in Article 7 is delayed beyond 28 December 2005, Member States shall comply with this obligation by the transposition date provided in the Directive containing these implementing measures. They shall forthwith communicate to the Commission the text of those provisions and a correlation table between those provisions and this Directive.

They shall apply those provisions from 9 November 2006 or, if the adoption of the implementing measures referred to in Article 7 is delayed beyond 28 December 2005, from the transposition date specified in the Directive containing these implementing measures.

When Member States adopt those provisions, they shall contain a reference to this Directive or be accompanied by such a reference on the occasion of their official publication. They shall also include a statement that references in existing laws, regulations and administrative provisions to the Directives repealed by this Directive shall be construed as references to this Directive. Member States shall determine how such reference is to be made and how that statement is to be formulated.

2 Member States shall communicate to the Commission the text of the main provisions of national law which they adopt in the field covered by this Directive.

Article 10

Repeal

The Directives listed in Annex IX, Part A, are repealed with effect from 9 November 2006 without prejudice to the obligations of the Member States relating to the time limits for transposition into national law and application of the Directives set out in Annex IX, Part B.

References to the repealed Directives shall be construed as references to this Directive and shall be read in accordance with the correlation table in Annex X.

Article 11

Entry into force

This Directive shall enter into force on the 20th day following its publication in the *Official Journal of the European Union*.

Article 12

Addressees

This Directive is addressed to the Member States.

Done at Strasbourg, 28 September 2005.

For the European Parliament

The President

J. BORRELL FONTELLES

For the Council

The President

D. ALEXANDER

ANNEX I

SCOPE, DEFINITIONS AND ABBREVIATIONS, APPLICATION FOR EC TYPE-APPROVAL, SPECIFICATIONS AND TESTS AND CONFORMITY OF PRODUCTION

1. SCOPE

This Directive applies to the gaseous and particulate pollutants from all motor vehicles equipped with compression-ignition engines and to the gaseous pollutants from all motor vehicles equipped with positive ignition engines fuelled with natural gas or LPG, and to compression-ignition and positive ignition engines as specified in Article 1 with the exception of those vehicles of category N₁, N₂ and M₂ for which type-approval has been granted under Council Directive 70/220/EEC of 20 March 1970 on the approximation of the laws of the Member States on measures to be taken against air pollution by emissions from motor vehicles⁽¹⁰⁾.

2. DEFINITIONS AND ABBREVIATIONS

For the purposes of this Directive:

- 2.1. *'test cycle'* means a sequence of test points each with a defined speed and torque to be followed by the engine under steady state (ESC test) or transient operating conditions (ETC, ELR test);
- 2.2. *'approval of an engine (engine family)'* means the approval of an engine type (engine family) with regard to the level of the emission of gaseous and particulate pollutants;
- 2.3. *'diesel engine'* means an engine which works on the compression-ignition principle;
- 2.4. *'gas engine'* means an engine which is fuelled with natural gas (NG) or liquid petroleum gas (LPG);
- 2.5. *'engine type'* means a category of engines which do not differ in such essential respects as engine characteristics as defined in Annex II to this Directive;
- 2.6. *'engine family'* means a manufacturers grouping of engines which, through their design as defined in Annex II, Appendix 2 to this Directive, have similar exhaust emission characteristics; all members of the family must comply with the applicable emission limit values;
- 2.7. *'parent engine'* means an engine selected from an engine family in such a way that its emissions characteristics will be representative for that engine family;
- 2.8. *'gaseous pollutants'* means carbon monoxide, hydrocarbons (assuming a ratio of CH_{1,85} for diesel, CH_{2,525} for LPG and CH_{2,93} for NG (NMHC), and an assumed molecule CH₃O_{0,5} for ethanol-fuelled diesel engines), methane (assuming a ratio of CH₄ for NG) and oxides of nitrogen, the last named being expressed in nitrogen dioxide (NO₂) equivalent;
- 2.9. *'particulate pollutants'* means any material collected on a specified filter medium after diluting the exhaust with clean filtered air so that the temperature does not exceed 325 K (52 °C);
- 2.10. *'smoke'* means particles suspended in the exhaust stream of a diesel engine which absorb, reflect, or refract light;
- 2.11. *'net power'* means the power in EC kW obtained on the test bench at the end of the crankshaft, or its equivalent, measured in accordance with the EC method of

measuring power as set out in Council Directive 80/1269/EEC of 16 December 1980 on the approximation of the laws of the Member States relating to the engine power of motor vehicles⁽¹¹⁾;

- 2.12. *'declared maximum power (P_{max})'* means the maximum power in EC kW (net power) as declared by the manufacturer in his application for type-approval;
- 2.13. *'per cent load'* means the fraction of the maximum available torque at an engine speed;
- 2.14. *'ESC test'* means a test cycle consisting of 13 steady state modes to be applied in accordance with Section 6.2 of this Annex;
- 2.15. *'ELR test'* means a test cycle consisting of a sequence of load steps at constant engine speeds to be applied in accordance with Section 6.2 of this Annex;
- 2.16. *'ETC test'* means a test cycle consisting of 1 800 second-by-second transient modes to be applied in accordance with Section 6.2 of this Annex;
- 2.17. *'engine operating speed range'* means the engine speed range, most frequently used during engine field operation, which lies between the low and high speeds, as set out in Annex III to this Directive;
- 2.18. *'low speed (n_{lo})'* means the lowest engine speed where 50 % of the declared maximum power occurs;
- 2.19. *'high speed (n_{hi})'* means the highest engine speed where 70 % of the declared maximum power occurs;
- 2.20. *'engine speeds A, B and C'* means the test speeds within the engine operating speed range to be used for the ESC test and the ELR test, as set out in Annex III, Appendix 1 to this Directive;
- 2.21. *'control area'* means the area between the engine speeds A and C and between 25 to 100 per cent load;
- 2.22. *'reference speed (n_{ref})'* means the 100 per cent speed value to be used for denormalising the relative speed values of the ETC test, as set out in Annex III, Appendix 2 to this Directive;
- 2.23. *'opacimeter'* means an instrument designed to measure the opacity of smoke particles by means of the light extinction principle;
- 2.24. *'NG gas range'* means one of the H or L range as defined in European Standard EN 437, dated November 1993;
- 2.25. *'self adaptability'* means any engine device allowing the air/fuel ratio to be kept constant;
- 2.26. *'recalibration'* means a fine tuning of an NG engine in order to provide the same performance (power, fuel consumption) in a different range of natural gas;
- 2.27. *'Wobbe Index (lower W_i ; or upper W_u)'* means the ratio of the corresponding calorific value of a gas per unit volume and the square root of its relative density under the same reference conditions:

$$W = H_{gas} \times \sqrt{\rho_{air} / \rho_{gas}}$$

- 2.28. *' λ -shift factor (S_i)'* means an expression that describes the required flexibility of the engine management system regarding a change of the excess-air ratio λ if the engine

is fuelled with a gas composition different from pure methane (see Annex VII for the calculation of S_i);

- 2.29. 'defeat device' means a device which measures, senses or responds to operating variables (e.g. vehicle speed, engine speed, gear used, temperature, intake pressure or any other parameter) for the purpose of activating, modulating, delaying or deactivating the operation of any component or function of the emission control system such that the effectiveness of the emission control system is reduced under conditions encountered during normal vehicle use unless the use of such a device is substantially included in the applied emission certification test procedures.

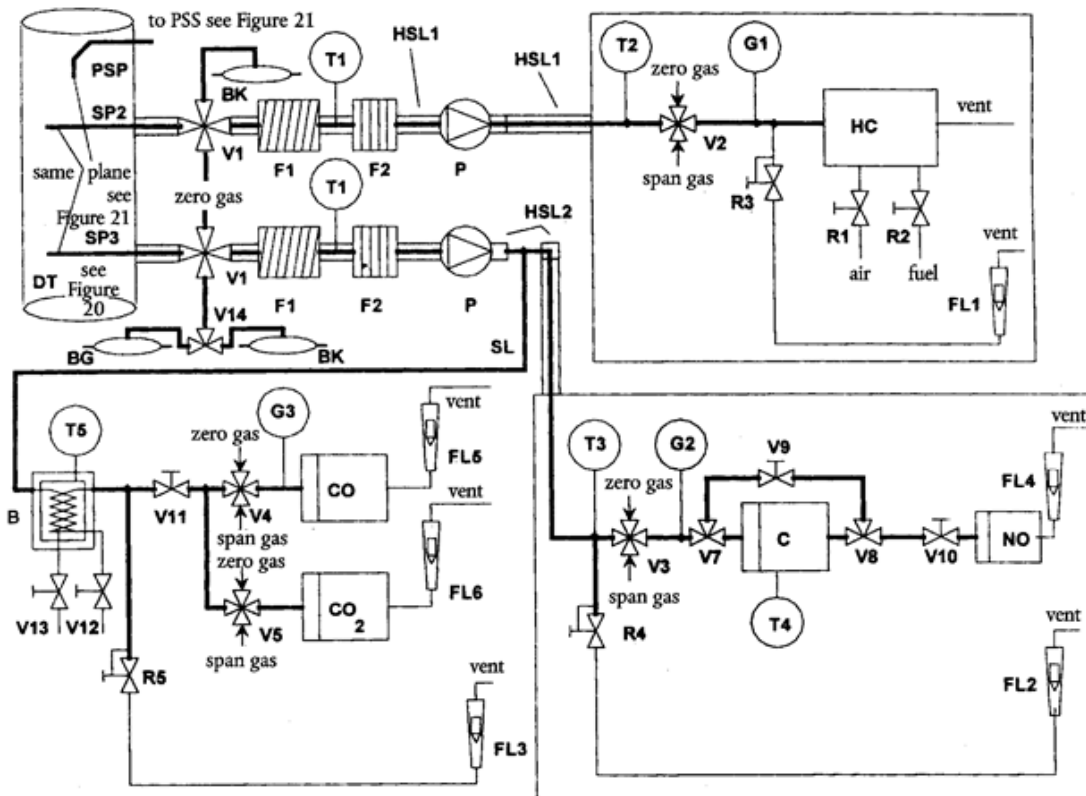

- 2.30. 'auxiliary control device' means a system, function or control strategy installed to an engine or on a vehicle, that is used to protect the engine and/or its ancillary equipment against operating conditions that could result in damage or failure, or is used to facilitate engine starting. An auxiliary control device may also be a strategy or measure that has been satisfactorily demonstrated not to be a defeat device;
- 2.31. 'irrational emission control strategy' means any strategy or measure that, when the vehicle is operated under normal conditions of use, reduces the effectiveness of the emission control system to a level below that expected on the applicable emission test procedures.
- 2.32. **Symbols and abbreviations**
- 2.32.1. *Symbols for test parameters*

Symbol	Unit	Term
--------	------	------

A_P	m^2	Cross sectional area of the isokinetic sampling probe
A_T	m^2	Cross sectional area of the exhaust pipe
CE_E	—	Ethane efficiency
CE_M	—	Methane efficiency
C1	—	Carbon 1 equivalent hydrocarbon
conc	ppm/vol. %	Subscript denoting concentration
D_0	m^3/s	Intercept of PDP calibration function
DF	—	Dilution factor
D	—	Bessel function constant
E	—	Bessel function constant
E_Z	g/kWh	Interpolated NO_x emission of the control point
f_a	—	Laboratory atmospheric factor
f_c	s^{-1}	Bessel filter cut-off frequency
F_{FH}	—	Fuel specific factor for the calculation of wet concentration for dry concentration
F_S	—	Stoichiometric factor
G_{AIRW}	kg/h	Intake air mass flow rate on wet basis
G_{AIRD}	kg/h	Intake air mass flow rate on dry basis
G_{DILW}	kg/h	Dilution air mass flow rate on wet basis
G_{EDFW}	kg/h	Equivalent diluted exhaust gas mass flow rate on wet basis
G_{EXHW}	kg/h	Exhaust gas mass flow rate on wet basis
G_{FUEL}	kg/h	Fuel mass flow rate
G_{TOTW}	kg/h	Diluted exhaust gas mass flow rate on wet basis
H	MJ/m^3	Calorific value

Status: This is the original version (as it was originally adopted).

H_{REF}	g/kg	Reference value of absolute humidity (10,71g/kg)
H_a	g/kg	Absolute humidity of the intake air
H_d	g/kg	Absolute humidity of the dilution air
HTCRAT	mol/mol	Hydrogen-to-Carbon ratio
i	—	Subscript denoting an individual mode
K	—	Bessel constant
k	m^{-1}	Light absorption coefficient
$K_{H,D}$	—	Humidity correction factor for NO_x for diesel engines
$K_{H,G}$	—	Humidity correction factor for NO_x for gas engines
K_V		CFV calibration function
$K_{W,a}$	—	Dry to wet correction factor for the intake air
$K_{W,d}$	—	Dry to wet correction factor for the dilution air
$K_{W,e}$	—	Dry to wet correction factor for the diluted exhaust gas
$K_{W,r}$	—	Dry to wet correction factor for the raw exhaust gas
L	%	Percent torque related to the maximum torque for the test engine
L_a	m	Effective optical path length
m		Slope of PDP calibration function
mass	g/h or g	Subscript denoting emissions mass flow (rate)
M_{DIL}	kg	Mass of the dilution air sample passed through the particulate sampling filters
M_d	mg	Particulate sample mass of the dilution air collected
M_f	mg	Particulate sample mass collected

$M_{f,p}$	mg	Particulate sample mass collected on primary filter
$M_{f,b}$	mg	Particulate sample mass collected on back-up filter
M_{SAM}		Mass of the diluted exhaust sample passed through the particulate sampling filters
M_{SEC}	kg	Mass of secondary dilution air
M_{TOTW}	kg	Total CVS mass over the cycle on wet basis
$M_{TOTW,i}$	kg	Instantaneous CVS mass on wet basis
N	%	Opacity
N_P	—	Total revolutions of PDP over the cycle
$N_{P,i}$	—	Revolutions of PDP during a time interval
n	min^{-1}	Engine speed
n_p	s^{-1}	PDP speed
n_{hi}	min^{-1}	High engine speed
n_{lo}	min^{-1}	Low engine speed
n_{ref}	min^{-1}	Reference engine speed for ETC test
p_a	kPa	Saturation vapour pressure of the engine intake air
p_A	kPa	Absolute pressure
p_B	kPa	Total atmospheric pressure
p_d	kPa	Saturation vapour pressure of the dilution air
p_s	kPa	Dry atmospheric pressure
p_i	kPa	Pressure depression at pump inlet
$P(a)$	kW	Power absorbed by auxiliaries to be fitted for test
$P(b)$	kW	Power absorbed by auxiliaries to be removed for test
$P(n)$	kW	Net power non-corrected

Status: This is the original version (as it was originally adopted).

$P(m)$	kW	Power measured on test bed
Ω	—	Bessel constant
Q_s	m^3/s	CVS volume flow rate
q	—	Dilution ratio
r	—	Ratio of cross sectional areas of isokinetic probe and exhaust pipe
R_a	%	Relative humidity of the intake air
R_d	%	Relative humidity of the dilution air
R_f	—	FID response factor
ρ	kg/m^3	Density
S	kW	Dynamometer setting
S_i	m^{-1}	Instantaneous smoke value
S_λ		λ -shift factor
T	K	Absolute temperature
T_a	K	Absolute temperature of the intake air
t	s	Measuring time
t_e	s	Electrical response time
t_F	s	Filter response time for Bessel function
t_p	s	Physical response time
Δt	s	Time interval between successive smoke data (= 1/ sampling rate)
Δt_i	s	Time interval for instantaneous CFV flow
τ	%	Smoke transmittance
V_0	m^3/rev	PDP volume flow rate at actual conditions
W	—	Wobbe index
W_{act}	kWh	Actual cycle work of ETC
W_{ref}	kWh	Reference cycle work of ETC
WF	—	Weighting factor
WF_E	—	Effective weighting factor

X_0	m^3/rev	Calibration function of PDP volume flow rate
Y_i	m^{-1}	1 s Bessel averaged smoke value

2.32.2. Symbols for chemical components

CH ₄	Methane
C ₂ H ₆	Ethane
C ₂ H ₅ OH	Ethanol
C ₃ H ₈	Propane
CO	Carbon monoxide
DOP	Di-octylphthalate
CO ₂	Carbon dioxide
HC	Hydrocarbons
NMHC	Non-methane hydrocarbons
NO _x	Oxides of nitrogen
NO	Nitric oxide
NO ₂	Nitrogen dioxide
PT	Particulates.

2.32.3. Abbreviations

CFV	Critical flow venturi
CLD	Chemiluminescent detector
ELR	European load response test
ESC	European steady state cycle
ETC	European transient cycle
FID	Flame ionisation detector
GC	Gas chromatograph
HCLD	Heated chemiluminescent detector
HFID	Heated flame ionisation detector
LPG	Liquefied petroleum gas
NDIR	Non-dispersive infrared analyser
NG	Natural gas
NMC	Non-methane cutter

3. APPLICATION FOR EC TYPE-APPROVAL
 - 3.1. Application for EC type-approval for a type of engine or engine family as a separate technical unit
 - 3.1.1. The application for approval of an engine type or engine family with regard to the level of the emission of gaseous and particulate pollutants for diesel engines and with regard to the level of the emission of gaseous pollutants for gas engines shall be submitted by the engine manufacturer or by a duly accredited representative.
 - 3.1.2. It shall be accompanied by the undermentioned documents in triplicate and the following particulars:
 - 3.1.2.1. A description of the engine type or engine family, if applicable, comprising the particulars referred to in Annex II to this Directive which conform to the requirements of Articles 3 and 4 of Directive 70/156/EEC of 6 February 1970 on the approximation of the laws of the Member States relating to the type-approval of motor vehicles and their trailers⁽¹²⁾.
 - 3.1.3. An engine conforming to the 'engine type' or 'parent engine' characteristics described in Annex II shall be submitted to the technical service responsible for conducting the approval tests defined in Section 6.
 - 3.2. Application for EC type-approval for a vehicle type in respect of its engine
 - 3.2.1. The application for approval of a vehicle with regard to emission of gaseous and particulate pollutants by its diesel engine or engine family and with regard to the level of the emission of gaseous pollutants by its gas engine or engine family shall be submitted by the vehicle manufacturer or a duly accredited representative.
 - 3.2.2. It shall be accompanied by the undermentioned documents in triplicate and the following particulars:
 - 3.2.2.1. A description of the vehicle type, of the engine-related vehicle parts and of the engine type or engine family, if applicable, comprising the particulars referred to in Annex II, along with the documentation required in application of Article 3 of Directive 70/156/EEC.
 - 3.3. Application for EC type-approval for a vehicle type with an approved engine
 - 3.3.1. The application for approval of a vehicle with regard to emission of gaseous and particulate pollutants by its approved diesel engine or engine family and with regard to the level of the emission of gaseous pollutants by its approved gas engine or engine family shall be submitted by the vehicle manufacturer or a duly accredited representative.
 - 3.3.2. It shall be accompanied by the undermentioned documents in triplicate and the following particulars:
 - 3.3.2.1. a description of the vehicle type and of engine-related vehicle parts comprising the particulars referred to in Annex II, as applicable, and a copy of the EC Type-Approval Certificate (Annex VI) for the engine or engine family, if applicable, as a separate technical unit which is installed in the vehicle type, along with the documentation required in application of Article 3 of Directive 70/156/EEC.
4. EC TYPE-APPROVAL

4.1. Granting of a universal fuel EC type-approval

A universal fuel EC type-approval is granted subject to the following requirements.

- 4.1.1. In the case of diesel fuel the parent engine meets the requirements of this Directive on the reference fuel specified in Annex IV.
- 4.1.2. In the case of natural gas the parent engine should demonstrate its capability to adapt to any fuel composition that may occur across the market. In the case of natural gas there are generally two types of fuel, high calorific fuel (H-gas) and low calorific fuel (L-gas), but with a significant spread within both ranges; they differ significantly in their energy content expressed by the Wobbe Index and in their λ -shift factor (S_λ). The formulae for the calculation of the Wobbe index and S_λ are given in Sections 2.27 and 2.28. Natural gases with a λ -shift factor between 0,89 and 1,08 ($0,89 \leq S_\lambda \leq 1,08$) are considered to belong to H-range, while natural gases with a λ -shift factor between 1,08 and 1,19 ($1,08 \leq S_\lambda \leq 1,19$) are considered to belong to L-range. The composition of the reference fuels reflects the extreme variations of S_λ .

The parent engine shall meet the requirements of this Directive on the reference fuels G_R (fuel 1) and G_{25} (fuel 2), as specified in Annex IV, without any readjustment to the fuelling between the two tests. However, one adaptation run over one ETC cycle without measurement is permitted after the change of the fuel. Before testing, the parent engine shall be run-in using the procedure given in paragraph 3 of Appendix 2 to Annex III.

- 4.1.2.1. On the manufacturer's request the engine may be tested on a third fuel (fuel 3) if the λ -shift factor (S_λ) lies between 0,89 (i.e. the lower range of G_R) and 1,19 (i.e. the upper range of G_{25}) for example when fuel 3 is a market fuel. The results of this test may be used as a basis for the evaluation of the conformity of the production.
- 4.1.3. In the case of an engine fuelled with natural gas which is self-adaptive for the range of H-gases on the one hand and the range of L-gases on the other hand, and which switches between the H-range and the L-range by means of a switch, the parent engine shall be tested on the relevant reference fuel as specified in Annex IV for each range, at each position of the switch. The fuels are G_R (fuel 1) and G_{23} (fuel 3) for the H-range of gases and G_{25} (fuel 2) and G_{23} (fuel 3) for the L-range of gases. The parent engine shall meet the requirements of this Directive at both positions of the switch without any readjustment to the fuelling between the two tests at each position of the switch. However, one adaptation run over one ETC cycle without measurement is permitted after the change of the fuel. Before testing the parent engine shall be run-in using the procedure given in paragraph 3 of Appendix 2 to Annex III.
- 4.1.3.1. At the manufacturer's request the engine may be tested on a third fuel instead of G_{23} (fuel 3) if the λ -shift factor (S_λ) lies between 0,89 (i.e. the lower range of G_R) and 1,19 (i.e. the upper range of G_{25}), for example when fuel 3 is a market fuel. The results of this test may be used as a basis for the evaluation of the conformity of the production.
- 4.1.4. In the case of natural gas engines, the ratio of the emission results 'r' shall be determined for each pollutant as follows:

$$r = \frac{\text{emission result on reference fuel 2}}{\text{emission result on reference fuel 1}}$$

or,

$$r = \frac{\text{emission result on reference fuel 2}}{\text{emission result on reference fuel 3}}$$

and,

$$r_b = \frac{\text{emission result on reference fuel 1}}{\text{emission result on reference fuel 3}}$$

4.1.5. In the case of LPG the parent engine should demonstrate its capability to adapt to any fuel composition that may occur across the market. In the case of LPG there are variations in C₃/C₄ composition. These variations are reflected in the reference fuels. The parent engine should meet the emission requirements on the reference fuels A and B as specified in Annex IV without any readjustment to the fuelling between the two tests. However, one adaptation run over one ETC cycle without measurement is permitted after the change of the fuel. Before testing, the parent engine shall be run-in using the procedure defined in paragraph 3 of Appendix 2 to Annex III.

4.1.5.1. The ratio of emission results 'r' shall be determined for each pollutant as follows:

$$r = \frac{\text{emission result on reference fuel B}}{\text{emission result on reference fuel A}}$$

4.2. Granting of a fuel range restricted EC type-approval

Fuel range restricted EC type-approval is granted subject to the following requirements:

4.2.1. Exhaust emissions approval of an engine running on natural gas and laid out for operation on either the range of H-gases or on the range of L-gases

The parent engine shall be tested on the relevant reference fuel, as specified in Annex IV, for the relevant range. The fuels are G_R (fuel 1) and G₂₃ (fuel 3) for the H-range of gases and G₂₅ (fuel 2) and G₂₃ (fuel 3) for the L-range of gases. The parent engine shall meet the requirements of this Directive without any readjustment to the fuelling between the two tests. However, one adaptation run over one ETC cycle without measurement is permitted after the change of the fuel. Before testing the parent engine shall be run-in using the procedure defined in paragraph 3 of Appendix 2 to Annex III.

4.2.1.1. At the manufacturer's request the engine may be tested on a third fuel instead of G₂₃ (fuel 3) if the λ-shift factor (S_λ) lies between 0,89 (i.e. the lower range of G_R) and 1,19 (i.e. the upper range of G₂₅), for example when fuel 3 is a market fuel. The results of this test may be used as a basis for the evaluation of the conformity of the production.

4.2.1.2. The ratio of emission results 'r' shall be determined for each pollutant as follows:

$$r = \frac{\text{emission result on reference fuel 2}}{\text{emission result on reference fuel 1}}$$

or,

$$r_a = \frac{\text{emission result on reference fuel 2}}{\text{emission result on reference fuel 3}}$$

and,

$$r_b = \frac{\text{emission result on reference fuel 1}}{\text{emission result on reference fuel 3}}$$

4.2.1.3. On delivery to the customer the engine shall bear a label (see paragraph 5.1.5) stating for which range of gases the engine is approved.

4.2.2. Exhaust emissions approval of an engine running on natural gas or LPG and laid out for operation on one specific fuel composition

4.2.2.1. The parent engine shall meet the emission requirements on the reference fuels G_R and G₂₅ in the case of natural gas, or the reference fuels A and B in the case of LPG, as specified in Annex IV. Between the tests fine-tuning of the fuelling system is allowed. This fine-tuning will consist of a recalibration of the fuelling database, without any alteration to either the basic control strategy or the basic structure of the database. If

necessary the exchange of parts that are directly related to the amount of fuel flow (such as injector nozzles) is allowed.

4.2.2.2. At the manufacturer's request the engine may be tested on the reference fuels G_R and G_{23} , or on the reference fuels G_{25} and G_{23} , in which case the type-approval is only valid for the H-range or the L-range of gases respectively.

4.2.2.3. On delivery to the customer the engine shall bear a label (see paragraph 5.1.5) stating for which fuel composition the engine has been calibrated.

4.3. Exhaust emissions approval of a member of a family

4.3.1. With the exception of the case mentioned in paragraph 4.3.2, the approval of a parent engine shall be extended to all family members without further testing, for any fuel composition within the range for which the parent engine has been approved (in the case of engines described in paragraph 4.2.2) or the same range of fuels (in the case of engines described in either paragraphs 4.1 or 4.2) for which the parent engine has been approved.

4.3.2. Secondary test engine

In case of an application for type-approval of an engine, or a vehicle in respect of its engine, that engine belonging to an engine family, if the technical service determines that, with regard to the selected parent engine the submitted application does not fully represent the engine family defined in Annex I, Appendix 1, an alternative and if necessary an additional reference test engine may be selected by the technical service and tested.

4.4. Type-approval certificate

A certificate conforming to the model specified in Annex VI shall be issued for approval referred to under Sections 3.1, 3.2 and 3.3.

5. ENGINE MARKINGS

5.1. The engine approved as a technical unit must bear:

5.1.1. the trademark or trade name of the manufacturer of the engine;

5.1.2. the manufacturer's commercial description;

5.1.3. the EC type-approval number preceded by the distinctive letter(s) or number(s) of the country granting EC type-approval⁽¹³⁾;

5.1.4. in case of an NG engine one of the following markings to be placed after the EC type approval number:

— H in case of the engine being approved and calibrated for the H-range of gases;

— L in case of the engine being approved and calibrated for the L-range of gases;

— HL in case of the engine being approved and calibrated for both the H-range and L-range of gases;

— H_t in case of the engine being approved and calibrated for a specific gas composition in the H-range of gases and transformable to another specific gas in the H-range of gases by fine tuning of the engine fuelling;

— L_t in case of the engine being approved and calibrated for a specific gas composition in the L-range of gases and transformable to another specific gas in the L-range of gases after fine tuning of the engine fuelling;

- HL_t in the case of the engine being approved and calibrated for a specific gas composition in either the H-range or the L-range of gases and transformable to another specific gas in either the H-range or the L-range of gases by fine tuning of the engine fuelling.

5.1.5. Labels

In the case of NG and LPG fuelled engines with a fuel range restricted type approval, the following labels are applicable:

5.1.5.1. Content

The following information must be given:

In the case of paragraph 4.2.1.3, the label shall state

‘ONLY FOR USE WITH NATURAL GAS RANGE H’. If applicable, ‘H’ is replaced by ‘L’.

In the case of paragraph 4.2.2.3, the label shall state

‘ONLY FOR USE WITH NATURAL GAS SPECIFICATION ...’ or ‘ONLY FOR USE WITH LIQUEFIED PETROLEUM GAS SPECIFICATION ...’, as applicable. All the information in the appropriate table(s) in Annex IV shall be given with the individual constituents and limits specified by the engine manufacturer.

The letters and figures must be at least 4 mm in height.

Note:

If lack of space prevents such labelling, a simplified code may be used. In this event, explanatory notes containing all the above information must be easily accessible to any person filling the fuel tank or performing maintenance or repair on the engine and its accessories, as well as to the authorities concerned. The site and content of these explanatory notes will be determined by agreement between the manufacturer and the approval authority.

5.1.5.2. Properties

Labels must be durable for the useful life of the engine. Labels must be clearly legible and their letters and figures must be indelible. Additionally, labels must be attached in such a manner that their fixing is durable for the useful life of the engine, and the labels cannot be removed without destroying or defacing them.

5.1.5.3. Placing

Labels must be secured to an engine part necessary for normal engine operation and not normally requiring replacement during engine life. Additionally, these labels must be located so as to be readily visible to the average person after the engine has been completed with all the auxiliaries necessary for engine operation.

5.2. In case of an application for EC type-approval for a vehicle type in respect of its engine, the marking specified in Section 5.1.5 shall also be placed close to fuel filling aperture.

5.3. In case of an application for EC type-approval for a vehicle type with an approved engine, the marking specified in Section 5.1.5 shall also be placed close to the fuel filling aperture.

6. SPECIFICATIONS AND TESTS

6.1. General

6.1.1. *Emission control equipment*

6.1.1.1. The components liable to affect the emission of gaseous and particulate pollutants from diesel engines and the emission of gaseous pollutants from gas engines shall be so designed, constructed, assembled and installed as to enable the engine, in normal use, to comply with the provisions of this Directive.

6.1.2. *Functions of emission control equipment*

6.1.2.1. The use of a defeat device and/or an irrational emission control strategy is forbidden.

6.1.2.2. An auxiliary control device may be installed to an engine, or on a vehicle, provided that the device:

- operates only outside the conditions specified in paragraph 6.1.2.4, or
- is activated only temporarily under the conditions specified in paragraph 6.1.2.4 for such purposes as engine damage protection, air-handling device protection, smoke management, cold start or warming-up, or
- is activated only by on-board signals for purposes such as operational safety and limp-home strategies.

6.1.2.3. An engine control device, function, system or measure that operates during the conditions specified in Section 6.1.2.4 and which results in the use of a different or modified engine control strategy to that normally employed during the applicable emission test cycles will be permitted if, in complying with the requirements of Sections 6.1.3 and/or 6.1.4, it is fully demonstrated that the measure does not reduce the effectiveness of the emission control system. In all other cases, such devices shall be considered to be a defeat device.

6.1.2.4. For the purposes of point 6.1.2.2, the defined conditions of use under steady state and transient conditions are:

- an altitude not exceeding 1 000 metres (or equivalent atmospheric pressure of 90 kPa),
- an ambient temperature within the range 283 to 303 K (10 to 30 °C),
- engine coolant temperature within the range 343 to 368 K (70 to 95 °C).

6.1.3. *Special requirements for electronic emission control systems*

6.1.3.1. *Documentation requirements*

The manufacturer shall provide a documentation package that gives access to the basic design of the system and the means by which it controls its output variables, whether that control is direct or indirect.

The documentation shall be made available in two parts:

- (a) the formal documentation package, which shall be supplied to the technical service at the time of submission of the type-approval application, shall include a full description of the system. This documentation may be brief, provided that it exhibits evidence that all outputs permitted by a matrix obtained from the range of control of the individual unit inputs have been identified. This information shall be attached to the documentation required in Annex I, Section 3;
- (b) additional material that shows the parameters that are modified by any auxiliary control device and the boundary conditions under which the device operates. The additional material shall include a description of the fuel system control logic, timing strategies and switch points during all modes of operation.

The additional material shall also contain a justification for the use of any auxiliary control device and include additional material and test data to demonstrate the effect on exhaust emissions of any auxiliary control device installed to the engine or on the vehicle.

This additional material shall remain strictly confidential and be retained by the manufacturer, but be made open for inspection at the time of type-approval or at any time during the validity of the type-approval.

- 6.1.4. To verify whether any strategy or measure should be considered a defeat device or an irrational emission control strategy according to the definitions given in Sections 2.29 and 2.31, the type-approval authority and/or the technical service may additionally request a NO_x screening test using the ETC which may be carried out in combination with either the type-approval test or the procedures for checking the conformity of production.
 - 6.1.4.1. As an alternative to the requirements of Appendix 4 to Annex III the emissions of NO_x during the ETC screening test may be sampled using the raw exhaust gas and the technical prescriptions of ISO DIS 16183, dated 15 October 2000, shall be followed.
 - 6.1.4.2. In verifying whether any strategy or measure should be considered a defeat device or an irrational emission control strategy according to the definitions given in Sections 2.29 and 2.31, an additional margin of 10 %, related to the appropriate NO_x limit value, shall be accepted.
- 6.1.5. Transitional provisions for extension of type-approval
 - 6.1.5.1. This section shall only be applicable to new compression-ignition engines and new vehicles propelled by a compression-ignition engine that have been type-approved to the requirements of row A of the tables in Section 6.2.1.
 - 6.1.5.2. As an alternative to Sections 6.1.3 and 6.1.4, the manufacturer may present to the technical service the results of a NO_x screening test using the ETC on the engine conforming to the characteristics of the parent engine described in Annex II, and taking into account the provisions of Sections 6.1.4.1 and 6.1.4.2. The manufacturer shall also provide a written statement that the engine does not employ any defeat device or irrational emission control strategy as defined in Section 2 of this Annex.
 - 6.1.5.3. The manufacturer shall also provide a written statement that the results of the NO_x screening test and the declaration for the parent engine, as referred to in Section 6.1.4, are also applicable to all engine types within the engine family described in Annex II.
- 6.2. Specifications concerning the emission of gaseous and particulate pollutants and smoke

For type approval to row A of the tables in Section 6.2.1, the emissions shall be determined on the ESC and ELR tests with conventional diesel engines including those fitted with electronic fuel injection equipment, exhaust gas recirculation (EGR), and/or oxidation catalysts. Diesel engines fitted with advanced exhaust aftertreatment systems including the NO_x catalysts and/or particulate traps, shall additionally be tested on the ETC test.

For type approval testing to either row B1 or B2 or row C of the tables in Section 6.2.1 the emissions shall be determined on the ESC, ELR and ETC tests.

For gas engines, the gaseous emissions shall be determined on the ETC test.

The ESC and ELR test procedures are described in Annex III, Appendix 1, the ETC test procedure in Annex III, Appendices 2 and 3.

The emissions of gaseous pollutants and particulate pollutants, if applicable, and smoke, if applicable, by the engine submitted for testing shall be measured by the methods described in Annex III, Appendix 4. Annex V describes the recommended analytical systems for the gaseous pollutants, the recommended particulate sampling systems, and the recommended smoke measurement system.

Other systems or analysers may be approved by the Technical Service if it is found that they yield equivalent results on the respective test cycle. The determination of system equivalency shall be based upon a 7 sample pair (or larger) correlation study between the system under consideration and one of the reference systems of this Directive. For particulate emissions only the full flow dilution system is recognised as the reference system. 'Results' refer to the specific cycle emissions value. The correlation testing shall be performed at the same laboratory, test cell, and on the same engine, and is preferred to be run concurrently. The equivalency criterion is defined as a $\pm 5\%$ agreement of the sample pair averages. For introduction of a new system into the Directive the determination of equivalency shall be based upon the calculation of repeatability and reproducibility, as described in ISO 5725.

6.2.1. Limit values

The specific mass of the carbon monoxide, of the total hydrocarbons, of the oxides of nitrogen and of the particulates, as determined on the ESC test, and of the smoke opacity, as determined on the ELR test, shall not exceed the amounts shown in Table 1.

TABLE 1

Limit values — ESC and ELR tests

Row	Mass of carbon monoxide(CO) g/kWh	Mass of hydrocarbons(HC) g/kWh	Mass of nitrogen oxides(NO _x) g/kWh	Mass of particulates(PT) g/kWh		Smoke ⁻¹
A (2000)	2,1	0,66	5,0	0,10	0,13 ^a	0,8
B1 (2005)	1,5	0,46	3,5	0,02		0,5
B2 (2008)	1,5	0,46	2,0	0,02		0,5
C (EEV)	1,5	0,25	2,0	0,02		0,15

^a For engines having a swept volume of less than 0,75 dm³ per cylinder and a rated power speed of more than 3 000 min⁻¹.

For diesel engines that are additionally tested on the ETC test, and specifically for gas engines, the specific masses of the carbon monoxide, of the non-methane hydrocarbons, of the methane (where applicable), of the oxides of nitrogen and of the particulates (where applicable) shall not exceed the amounts shown in Table 2.

TABLE 2

Limit values — ETC tests

Status: This is the original version (as it was originally adopted).

Row	Mass of carbon monoxide(CO) g/kWh	Mass of non-methane hydrocarbons(NMHC) g/kWh	Mass of methane(CH ₄) g/kWh	Mass of nitrogen oxides(NO _x) g/kWh	Mass of particulates(PT) ^b g/kWh	
A (2000)	5,45	0,78	1,6	5,0	0,16	0,21 ^c
B1 (2005)	4,0	0,55	1,1	3,5	0,03	
B2 (2008)	4,0	0,55	1,1	2,0	0,03	
C (EEV)	3,0	0,40	0,65	2,0	0,02	

a For NG engines only.

b Not applicable for gas fuelled engines at stage A and stages B1 and B2.

c For engines having a swept volume of less than 0,75 dm³ per cylinder and a rated power speed of more than 3 000 min⁻¹.

6.2.2. Hydrocarbon measurement for diesel and gas fuelled engines

6.2.2.1. A manufacturer may choose to measure the mass of total hydrocarbons (THC) on the ETC test instead of measuring the mass of non-methane hydrocarbons. In this case, the limit for the mass of total hydrocarbons is the same as shown in Table 2 for the mass of non-methane hydrocarbons.

6.2.3. Specific requirements for diesel engines

6.2.3.1. The specific mass of the oxides of nitrogen measured at the random check points within the control area of the ESC test must not exceed by more than 10 per cent the values interpolated from the adjacent test modes (reference Annex III, Appendix 1, Sections 4.6.2 and 4.6.3).

6.2.3.2. The smoke value on the random test speed of the ELR must not exceed the highest smoke value of the two adjacent test speeds by more than 20 per cent, or by more than 5 per cent of the limit value, whichever is greater.

7. INSTALLATION ON THE VEHICLE

7.1. The engine installation on the vehicle shall comply with the following characteristics in respect to the type-approval of the engine:

7.1.1. intake depression shall not exceed that specified for the type-approved engine in Annex VI;

7.1.2. exhaust back pressure shall not exceed that specified for the type-approved engine in Annex VI;

7.1.3. the exhaust system volume shall not differ by more than 40 % of that specified for the type-approved engine in Annex VI;

7.1.4. power absorbed by the auxiliaries needed for operating the engine shall not exceed that specified for the type-approved engine in Annex VI.

8. ENGINE FAMILY

8.1. Parameters defining the engine family

The engine family, as determined by the engine manufacturer, may be defined by basic characteristics which must be common to engines within the family. In some cases there may be interaction of parameters. These effects must also be taken into consideration to ensure that only engines with similar exhaust emission characteristics are included within an engine family.

In order that engines may be considered to belong to the same engine family, the following list of basic parameters must be common:

8.1.1. Combustion cycle:

- 2 cycle
- 4 cycle

8.1.2. Cooling medium:

- air
- water
- oil

8.1.3. For gas engines and engines with aftertreatment:

- number of cylinders

(other diesel engines with fewer cylinders than the parent engine may be considered to belong to the same engine family provided the fuelling system meters fuel for each individual cylinder)

8.1.4. Individual cylinder displacement:

- engines to be within a total spread of 15 %

8.1.5. Method of air aspiration:

- naturally aspirated
- pressure charged
- pressure charged with charge air cooler

8.1.6. Combustion chamber type/design:

- pre-chamber
- swirl chamber
- open chamber

8.1.7. Valve and porting — configuration, size and number:

- cylinder head
- cylinder wall
- crankcase

8.1.8. Fuel injection system (diesel engines):

- pump-line-injector
- in-line pump
- distributor pump
- single element
- unit injector

8.1.9. Fuelling system (gas engines):

- mixing unit
- gas induction/injection (single point, multi-point)
- liquid injection (single point, multi-point)

8.1.10. Ignition system (gas engines)

8.1.11. Miscellaneous features:

- exhaust gas recirculation
- water injection/emulsion
- secondary air injection
- charge cooling system

8.1.12. Exhaust aftertreatment:

- 3-way-catalyst
- oxidation catalyst
- reduction catalyst
- thermal reactor
- particulate trap

8.2. Choice of the parent engine

8.2.1. Diesel engines

The parent engine of the family shall be selected using the primary criteria of the highest fuel delivery per stroke at the declared maximum torque speed. In the event that two or more engines share this primary criteria, the parent engine shall be selected using the secondary criteria of highest fuel delivery per stroke at rated speed. Under certain circumstances, the approval authority may conclude that the worst case emission rate of the family can best be characterised by testing a second engine. Thus, the approval authority may select an additional engine for test based upon features which indicate that it may have the highest emission level of the engines within that family.

If engines within the family incorporate other variable features which could be considered to affect exhaust emissions, these features shall also be identified and taken into account in the selection of the parent engine.

8.2.2. Gas engines

The parent engine of the family shall be selected using the primary criteria of the largest displacement. In the event that two or more engines share this primary criteria, the parent engine shall be selected using the secondary criteria in the following order:

- the highest fuel delivery per stroke at the speed of declared rated power;
- the most advanced spark timing;
- the lowest EGR rate;
- no air pump or lowest actual air flow pump.

Under certain circumstances, the approval authority may conclude that the worst case emission rate of the family can best be characterised by testing a second engine. Thus, the approval authority may select an additional engine for test based upon features which indicate that it may have the highest emission level of the engines within that family.

9. PRODUCTION CONFORMITY

9.1. Measures to ensure production conformity must be taken in accordance with the provisions of Article 10 of Directive 70/156/EEC. Production conformity is checked on the basis of the description in the type-approval certificates set out in Annex VI to this Directive.

Sections 2.4.2 and 2.4.3 of Annex X to Directive 70/156/EEC are applicable where the competent authorities are not satisfied with the auditing procedure of the manufacturer.

9.1.1. If emissions of pollutants are to be measured and an engine type-approval has had one or several extensions, the tests will be carried out on the engine(s) described in the information package relating to the relevant extension.

9.1.1.1. Conformity of the engine subjected to a pollutant test:

After submission of the engine to the authorities, the manufacturer shall not carry out any adjustment to the engines selected.

9.1.1.1.1. Three engines are randomly taken in the series. Engines that are subject to testing only on the ESC and ELR tests or only on the ETC test for type approval to row A of the tables in Section 6.2.1 are subject to those applicable tests for the checking of production conformity. With the agreement of the authority, all other engines type approved to row A, B1 or B2, or C of the tables in Section 6.2.1 are subjected to testing either on the ESC and ELR cycles or on the ETC cycle for the checking of the production conformity. The limit values are given in Section 6.2.1 of this Annex.

9.1.1.1.2. The tests are carried out according to Appendix 1 to this Annex, where the competent authority is satisfied with the production standard deviation given by the manufacturer, in accordance with Annex X to Directive 70/156/EEC, which applies to motor vehicles and their trailers.

The tests are carried out according to Appendix 2 to this Annex, where the competent authority is not satisfied with the production standard deviation given by the manufacturer, in accordance with Annex X to Directive 70/156/EEC, which applies to motor vehicles and their trailers.

At the manufacturer's request, the tests may be carried out in accordance with Appendix 3 to this Annex.

9.1.1.1.3. On the basis of a test of the engine by sampling, the production of a series is regarded as conforming where a pass decision is reached for all the pollutants and non-conforming where a fail decision is reached for one pollutant, in accordance with the test criteria applied in the appropriate Appendix.

When a pass decision has been reached for one pollutant, this decision may not be changed by any additional tests made in order to reach a decision for the other pollutants.

If no pass decision is reached for all the pollutants and if no fail decision is reached for one pollutant, a test is carried out on another engine (see Figure 2).

If no decision is reached, the manufacturer may at any time decide to stop testing. In that case a fail decision is recorded.

9.1.1.2. The tests will be carried out on newly manufactured engines. Gas fuelled engines shall be run-in using the procedure defined in paragraph 3 of Appendix 2 to Annex III.

9.1.1.2.1. However, at the request of the manufacturer, the tests may be carried out on diesel or gas engines which have been run-in more than the period referred to in Section 9.1.1.2, up to a maximum of 100 hours. In this case, the running-in procedure will be conducted by the manufacturer who shall undertake not to make any adjustments to those engines.

9.1.1.2.2. When the manufacturer asks to conduct a running-in procedure in accordance with Section 9.1.1.2.1, it may be carried out on:

- all the engines that are tested, or
- the first engine tested, with the determination of an evolution coefficient as follows:
- the pollutant emissions will be measured at zero and at 'x' hours on the first engine tested,
- the evolution coefficient of the emissions between zero and

‘

x

’

hours will be calculated for each pollutant:

emissions 'x' hours/emissions zero hours

It may be less than one.

The subsequent test engines will not be subjected to the running-in procedure, but their zero hour emissions will be modified by the evolution coefficient.

In this case, the values to be taken will be:

- the values at 'x' hours for the first engine,
- the values at zero hour multiplied by the evolution coefficient for the other engines.

9.1.1.2.3. For diesel and LPG fuelled engines, all these tests may be conducted with commercial fuel. However, at the manufacturer's request, the reference fuels described in Annex IV may be used. This implies tests, as described in Section 4 of this Annex, with at least two of the reference fuels for each gas engine.

9.1.1.2.4. For NG fuelled engines, all these tests may be conducted with commercial fuel in the following way:

- for H marked engines with a commercial fuel within the H-range ($0,89 \leq S_\lambda \leq 1,00$),
- for L marked engines with a commercial fuel within the L-range ($1,00 \leq S_\lambda \leq 1,19$),
- for HL marked engines with a commercial fuel within the extreme range of the λ -shift factor ($0,89 \leq S_\lambda \leq 1,19$).

However, at the manufacturer's request, the reference fuels described in Annex IV may be used. This implies tests, as described in Section 4 of this Annex.

9.1.1.2.5. In the case of dispute caused by the non-compliance of gas fuelled engines when using a commercial fuel, the tests shall be performed with a reference fuel on which the parent engine has been tested, or with the possible additional fuel 3 as referred to in paragraphs 4.1.3.1 and 4.2.1.1 on which the parent engine may have been tested. Then, the result has to be converted by a calculation applying the relevant factor(s) 'r', 'ra' or 'rb' as described in paragraphs 4.1.4, 4.1.5.1 and 4.2.1.2. If r, ra or rb are less than 1 no correction shall take place. The measured results and the calculated results must demonstrate that the engine meets the limit values with all relevant fuels (fuels 1, 2 and, if applicable, fuel 3 in the case of natural gas engines and fuels A and B in the case of LPG engines).

9.1.1.2.6. Tests for conformity of production of a gas fuelled engine laid out for operation on one specific fuel composition shall be performed on the fuel for which the engine has been calibrated.

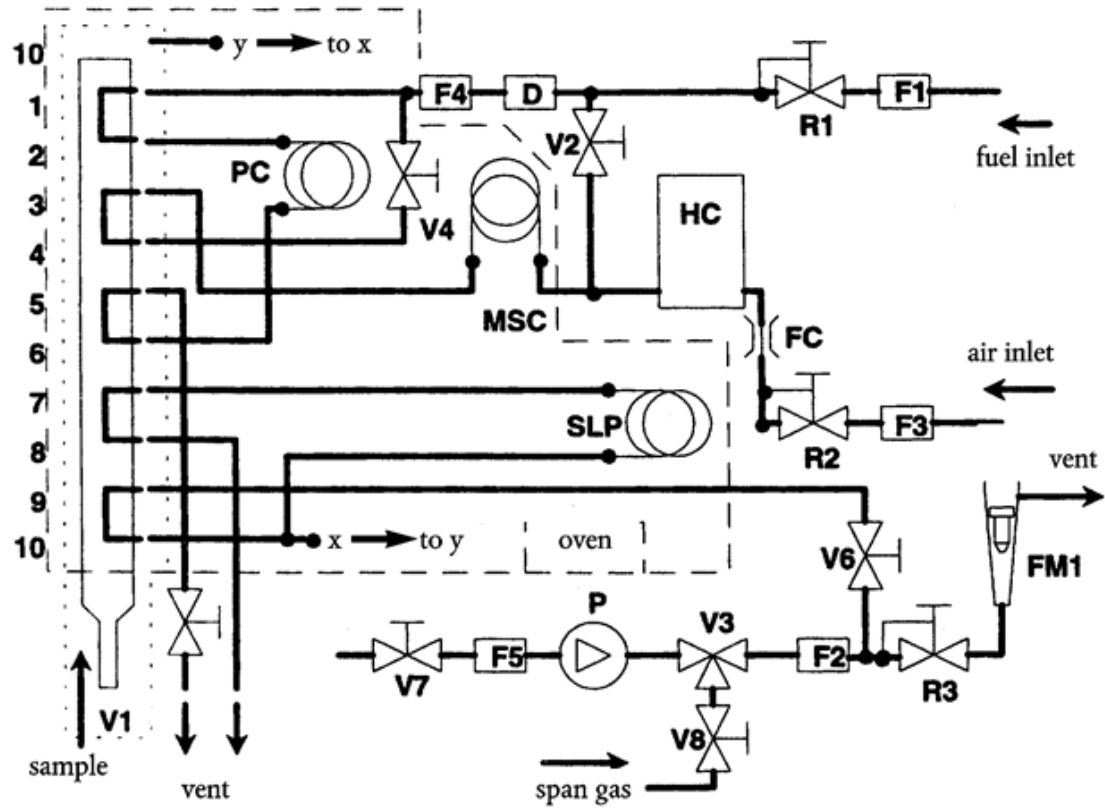

Appendix 1

PROCEDURE FOR PRODUCTION CONFORMITY TESTING
WHEN STANDARD DEVIATION IS SATISFACTORY

1. This Appendix describes the procedure to be used to verify production conformity for the emissions of pollutants when the manufacturer's production standard deviation is satisfactory.
2. With a minimum sample size of three engines the sampling procedure is set so that the probability of a lot passing a test with 40 % of the engines defective is 0,95 (producer's risk = 5 %) while the probability of a lot being accepted with 65 % of the engines defective is 0,10 (consumer's risk = 10 %).
3. The following procedure is used for each of the pollutants given in Section 6.2.1 of Annex I (see Figure 2):

Let:

L	=	the natural logarithm of the limit value for the pollutant;
χ_i	=	the natural logarithm of the measurement for the i-th engine of the sample;
s	=	an estimate of the production standard deviation (after taking the natural logarithm of the measurements);
n	=	the current sample number.

4. For each sample the sum of the standardised deviations to the limit is calculated using the following formula:

$$\frac{1}{n} \sum_{i=1}^n (L - \chi_i)$$

5. Then:
 - if the test statistic result is greater than the pass decision number for the sample size given in Table 3, a pass decision is reached for the pollutant;
 - if the test statistic result is less than the fail decision number for the sample size given in Table 3, a fail decision is reached for the pollutant;
 - otherwise, an additional engine is tested according to Section 9.1.1.1 of Annex I and the calculation procedure is applied to the sample increased by one more unit.

TABLE 3

Pass and fail decision numbers of Appendix 1 sampling plan Minimum sample size: 3

Cumulative number of engines tested (sample size)	Pass decision number A_n	Fail decision number B_n
3	3,327	- 4,724
4	3,261	- 4,79
5	3,195	- 4,856
6	3,129	- 4,922

Status: This is the original version (as it was originally adopted).

7	3,063	- 4,988
8	2,997	- 5,054
9	2,931	- 5,12
10	2,865	- 5,185
11	2,799	- 5,251
12	2,733	- 5,317
13	2,667	- 5,383
14	2,601	- 5,449
15	2,535	- 5,515
16	2,469	- 5,581
17	2,403	- 5,647
18	2,337	- 5,713
19	2,271	- 5,779
20	2,205	- 5,845
21	2,139	- 5,911
22	2,073	- 5,977
23	2,007	- 6,043
24	1,941	- 6,109
25	1,875	- 6,175
26	1,809	- 6,241
27	1,743	- 6,307
28	1,677	- 6,373
29	1,611	- 6,439
30	1,545	- 6,505
31	1,479	- 6,571
32	- 2,112	- 2,112

Appendix 2

PROCEDURE FOR PRODUCTION CONFORMITY TESTING WHEN STANDARD DEVIATION IS UNSATISFACTORY OR UNAVAILABLE

1. This Appendix describes the procedure to be used to verify production conformity for the emissions of pollutants when the manufacturer's production standard deviation is either unsatisfactory or unavailable.
2. With a minimum sample size of three engines the sampling procedure is set so that the probability of a lot passing a test with 40 % of the engines defective is 0,95 (producer's risk = 5 %) while the probability of a lot being accepted with 65 % of the engines defective is 0,10 (consumer's risk = 10 %).
3. The values of the pollutants given in Section 6.2.1 of Annex I are considered to be log normally distributed and should be transformed by taking their natural logarithms. Let m_0 and m denote the minimum and maximum sample size respectively ($m_0 = 3$ and $m = 32$) and let n denote the current sample number.
4. If the natural logarithms of the values measured in the series are $\chi_1, \chi_2, \dots, \chi_i$ and L is the natural logarithm of the limit value for the pollutant, then, define

$$d_i = \chi_i - L$$

and

$$\bar{d}_n = \frac{1}{n} \sum_{i=1}^n d_i$$

$$v_2^n = \frac{1}{n} \sum_{i=1}^n (d_i - \bar{d}_n)^2$$

5. Table 4 shows values of the pass (A_n) and fail (B_n) decision numbers against current sample number. The test statistic result is the ratio:

$$\bar{d}_n / V_n$$

and shall be used to determine whether the series has passed or failed as follows:

for $m_0 \leq n < m$:

— pass the series if

$$\bar{d}_n / v_n \leq A_n$$

— fail the series if

$$\bar{d}_n / v_n \geq B_n$$

— take another measurement if

$$A_n < \bar{d}_n / v_n < B_n$$

6. Remarks

The following recursive formulae are useful for calculating successive values of the test statistic:

$$\bar{d}_n = \left(1 - \frac{1}{n}\right) \bar{d}_{n-1} + \frac{1}{n} d_n$$

$$V_2^n = \left(1 - \frac{1}{n}\right) V_2^{n-1} + \left(\bar{d}_n - \bar{d}_{n-1}\right)^2 n - 1$$

$$(n = 2, 3, \dots; d_1 = d_1; V_1 = 0)$$

TABLE 4

Pass and fail decision numbers of Appendix 2 sampling plan Minimum sample size: 3

Cumulative number of engines tested (sample size)	Pass decision number A_n	Fail decision number B_n
3	- 0,80381	16,64743
4	- 0,76339	7,68627
5	- 0,72982	4,67136
6	- 0,69962	3,25573
7	- 0,67129	2,45431
8	- 0,64406	1,94369
9	- 0,6175	1,59105
10	- 0,59135	1,33295
11	- 0,56542	1,13566
12	- 0,5396	0,9797
13	- 0,51379	0,85307
14	- 0,48791	0,74801
15	- 0,46191	0,65928
16	- 0,43573	0,58321
17	- 0,40933	0,51718
18	- 0,38266	0,45922
19	- 0,3557	0,40788
20	- 0,3284	0,36203
21	- 0,30072	0,32078
22	- 0,27263	0,28343
23	- 0,2441	0,24943
24	- 0,21509	0,21831
25	- 0,18557	0,1897
26	- 0,1555	0,16328
27	- 0,12483	0,1388
28	- 0,09354	0,11603
29	- 0,06159	0,09480
30	- 0,02892	0,07493

Status: This is the original version (as it was originally adopted).

31	- 0,00449	0,05629
32	- 0,03876	0,03876

Appendix 3

PROCEDURE FOR PRODUCTION CONFORMITY
TESTING AT MANUFACTURER'S REQUEST

1. This Appendix describes the procedure to be used to verify, at the manufacturer's request, production conformity for the emissions of pollutants.
2. With a minimum sample size of three engines the sampling procedure is set so that the probability of a lot passing a test with 30 % of the engines defective is 0,90 (producer's risk = 10 %) while the probability of a lot being accepted with 65 % of the engines defective is 0,10 (consumer's risk = 10 %).
3. The following procedure is used for each of the pollutants given in Section 6.2.1 of Annex I (see Figure 2):

Let:

L	=	the limit value for the pollutant,
x_i	=	the value of the measurement for the i-th engine of the sample,
n	=	the current sample number.
4. Calculate for the sample the test statistic quantifying the number of non-conforming engines, i.e. $x_i \geq L$.
5. Then:
 - if the test statistic is less than or equal to the pass decision number for the sample size given in Table 5, a pass decision is reached for the pollutant;
 - if the test statistic is greater than or equal to the fail decision number for the sample size given in Table 5, a fail decision is reached for the pollutant;
 - otherwise, an additional engine is tested according to Section 9.1.1.1 of Annex I and the calculation procedure is applied to the sample increased by one more unit.

In Table 5 the pass and fail decision numbers are calculated by means of the International Standard ISO 8422/1991.

TABLE 5

Pass and fail decision numbers of Appendix 3 sampling plan Minimum sample size: 3

Cumulative number of engines tested (sample size)	Pass decision number	Fail decision number
3	—	3
4	0	4
5	0	4
6	1	5
7	1	5
8	2	6
9	2	6

Status: This is the original version (as it was originally adopted).

10	3	7
11	3	7
12	4	8
13	4	8
14	5	9
15	5	9
16	6	10
17	6	10
18	7	11
19	8	9

ANNEX II

- 2.2.1.7. Relative concentration:
- 2.2.1.8. Substrate (structure and material):
- 2.2.1.9. Cell density:
- 2.2.1.10. Type of casing for the catalytic converter(s):
- 2.2.1.11. Location of the catalytic converter(s) (place and reference distance in the exhaust line):
.....
- 2.2.2. Oxygen sensor: yes/no ⁽¹⁾
- 2.2.2.1. Make(s):
- 2.2.2.2. Type:
- 2.2.2.3. Location:
- 2.2.3. Air injection: yes/no ⁽¹⁾
- 2.2.3.1. Type (pulse air, air pump, etc.):
- 2.2.4. EGR: yes/no ⁽¹⁾
- 2.2.4.1. Characteristics (flow rate etc.):
- 2.2.5. Particulate trap: yes/no ⁽¹⁾
- 2.2.5.1. Dimensions, shape and capacity of the particulate trap:
- 2.2.5.2. Type and design of the particulate trap:
- 2.2.5.3. Location (reference distance in the exhaust line):
- 2.2.5.4. Method or system of regeneration, description and/or drawing:
- 2.2.6. Other systems: yes/no ⁽¹⁾
- 2.2.6.1. Description and operation:
3. **Fuel feed**
- 3.1. *Diesel engines*
- 3.1.1. Feed pump
- Pressure ⁽²⁾: kPa or characteristic diagram ⁽¹⁾:
- 3.1.2. Injection system
- 3.1.2.1. Pump
- 3.1.2.1.1. Make(s):
- 3.1.2.1.2. Type(s):
- 3.1.2.1.3. Delivery: mm³ ⁽²⁾ per stroke at engine speed of rpm at full injection, or characteristic diagram ⁽¹⁾ ⁽²⁾:
- Mention the method used: on engine/on pump bench ⁽¹⁾
- If boost control is supplied, state the characteristic fuel delivery and boost pressure versus engine speed.
- 3.1.2.1.4. Injection advance
- 3.1.2.1.4.1. Injection advance curve ⁽²⁾:
- 3.1.2.1.4.2. Static injection timing ⁽²⁾:
- 3.1.2.2. Injection piping
- 3.1.2.2.1. Length: mm
- 3.1.2.2.2. Internal diameter: mm
- 3.1.2.3. Injector(s)

Appendix 1

Speed

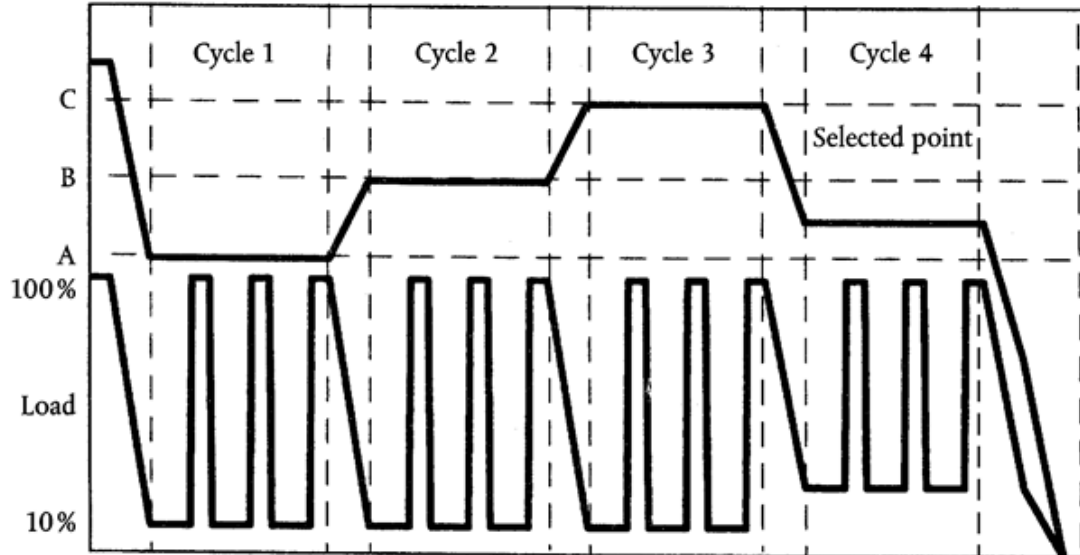

Torque

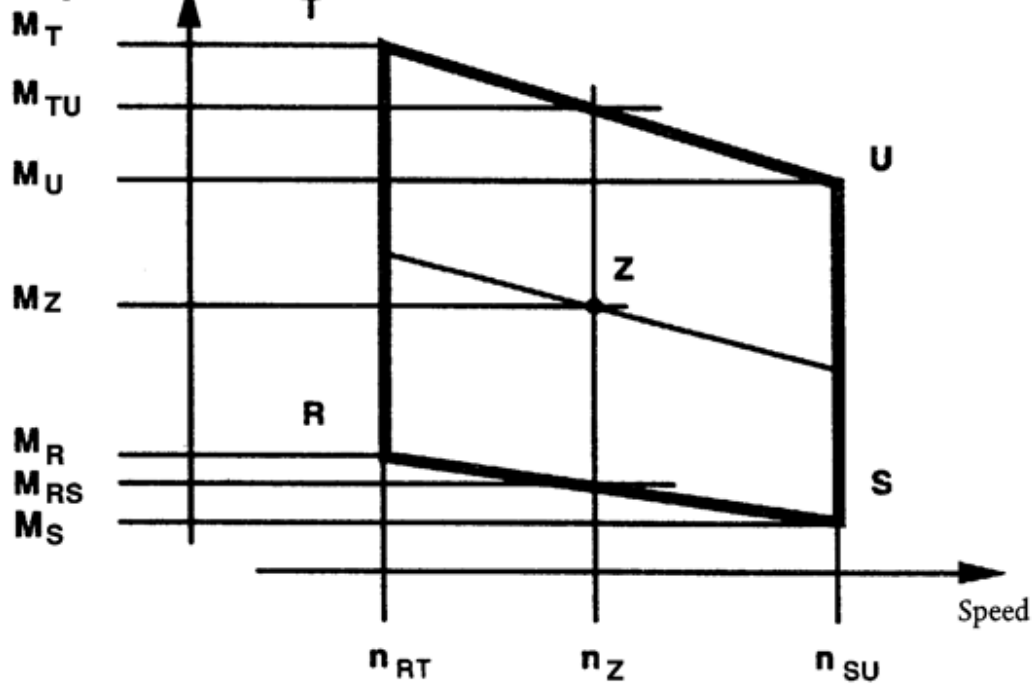

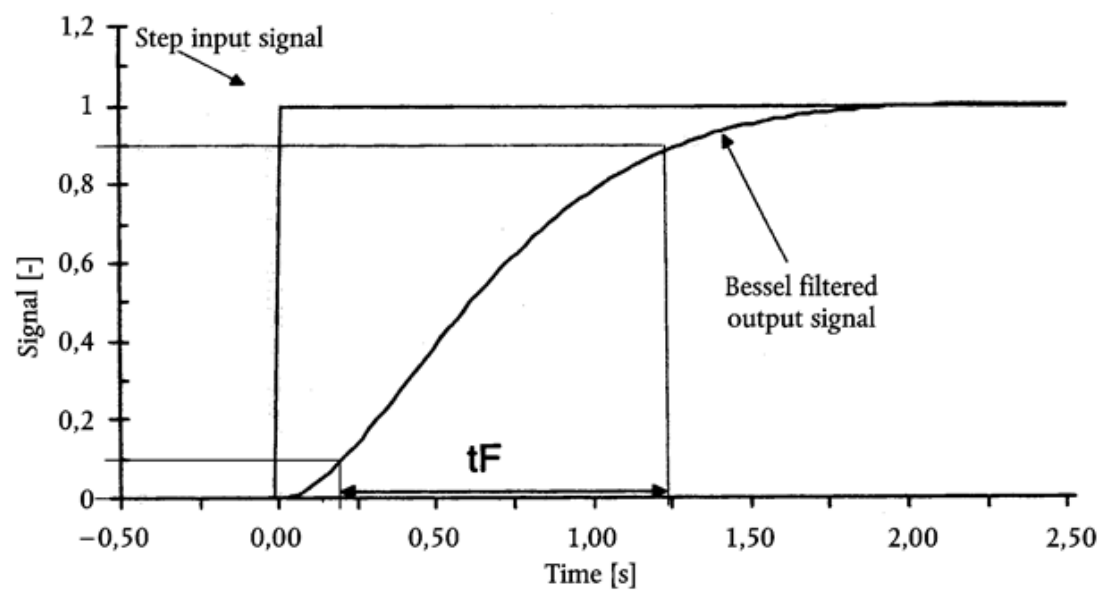

Status: This is the original version (as it was originally adopted).

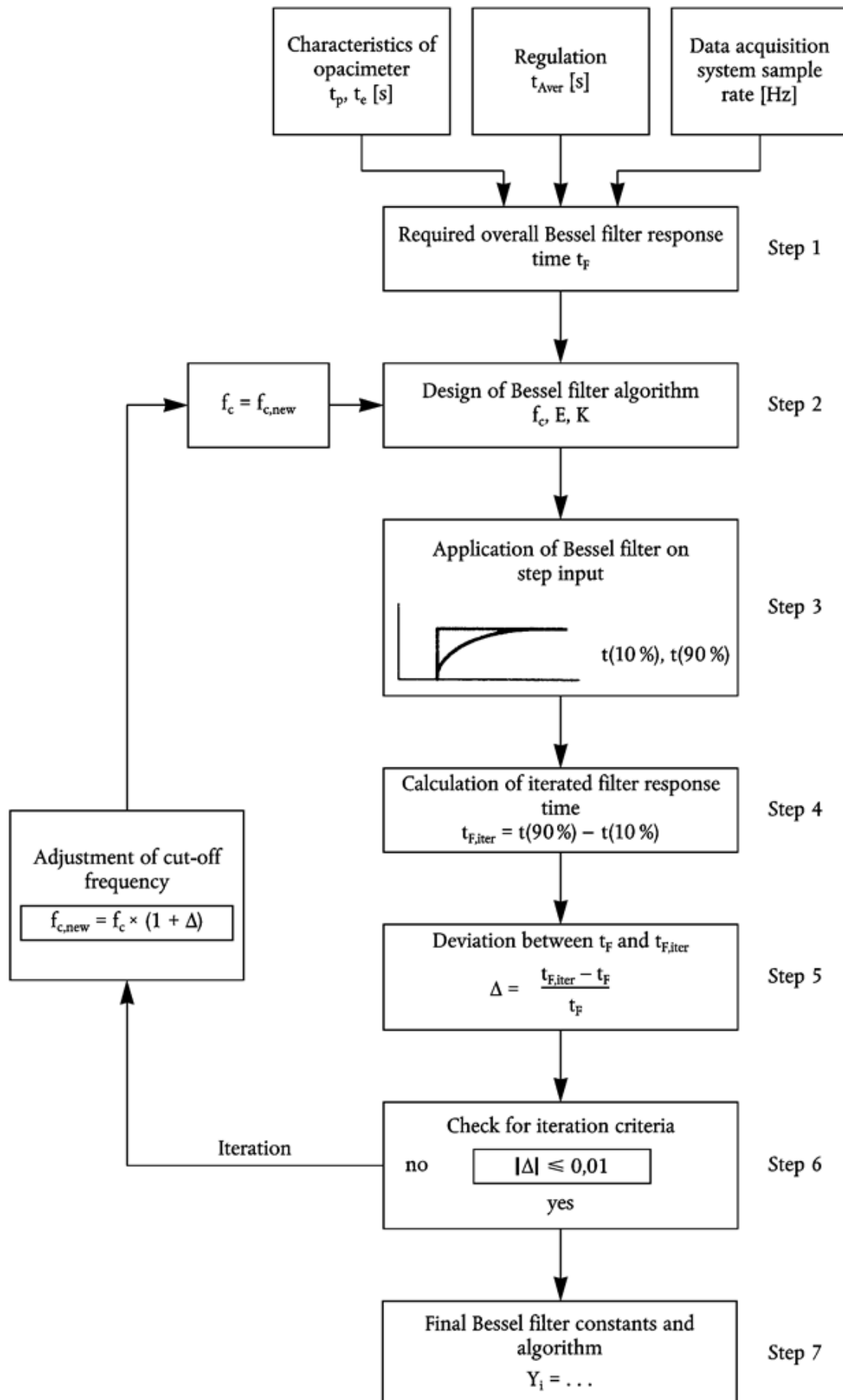

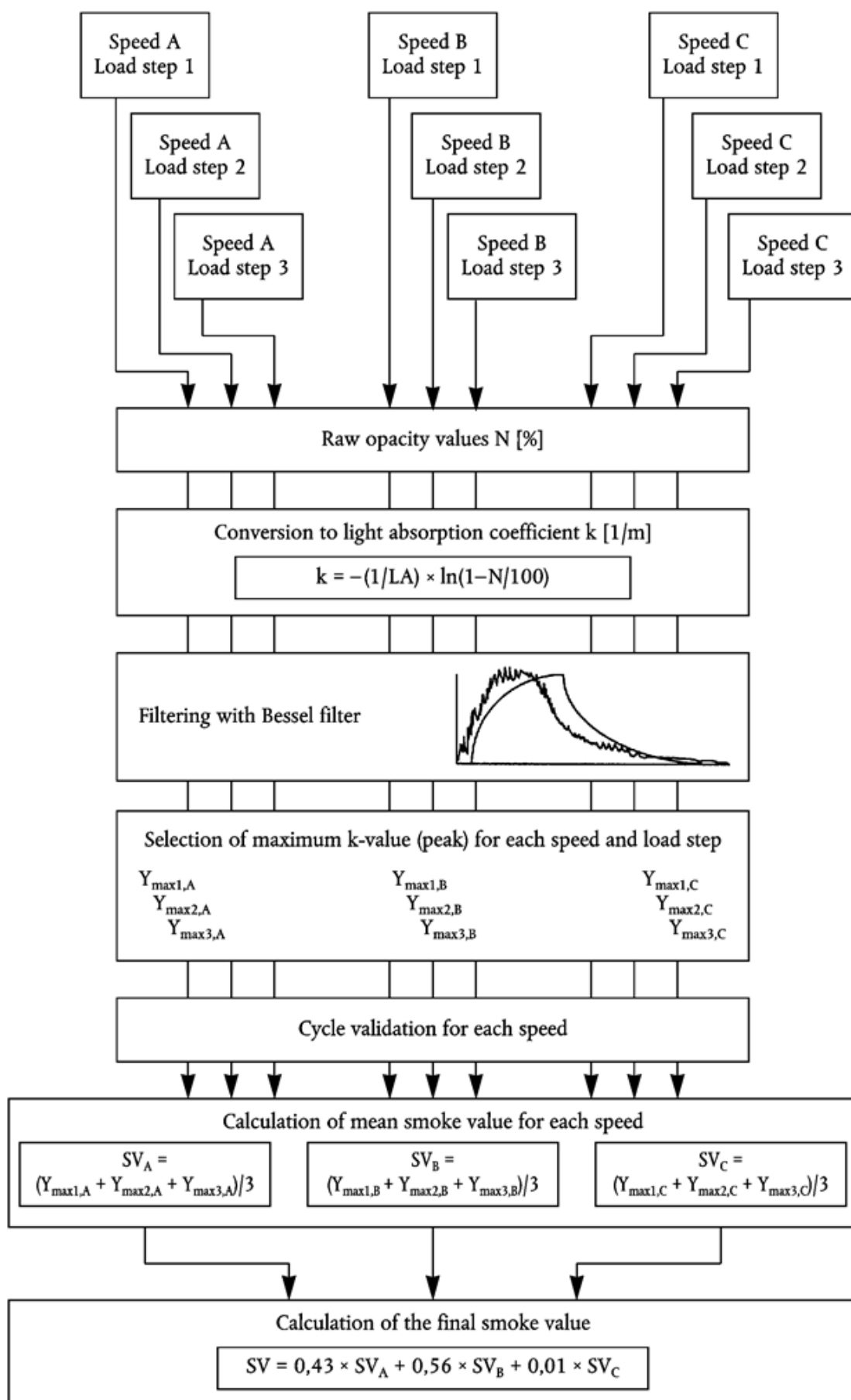

Status: This is the original version (as it was originally adopted).

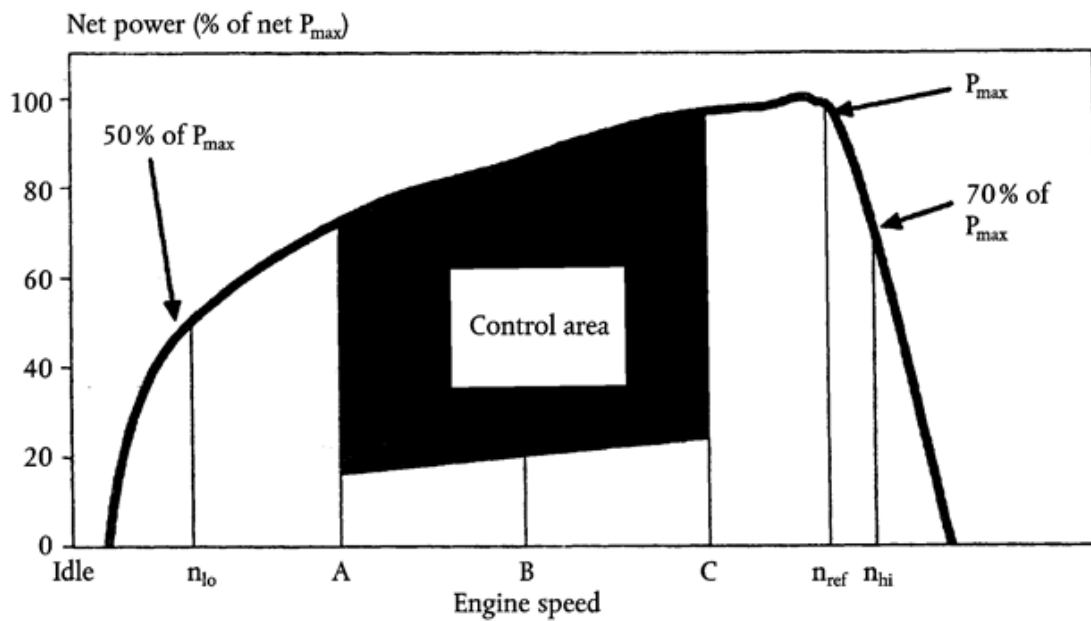
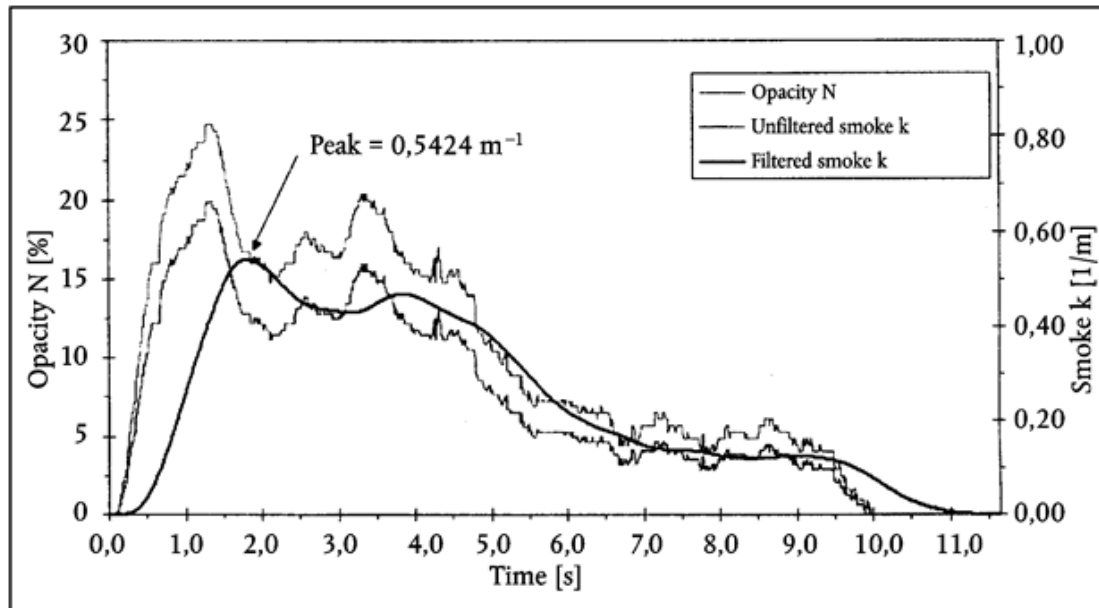

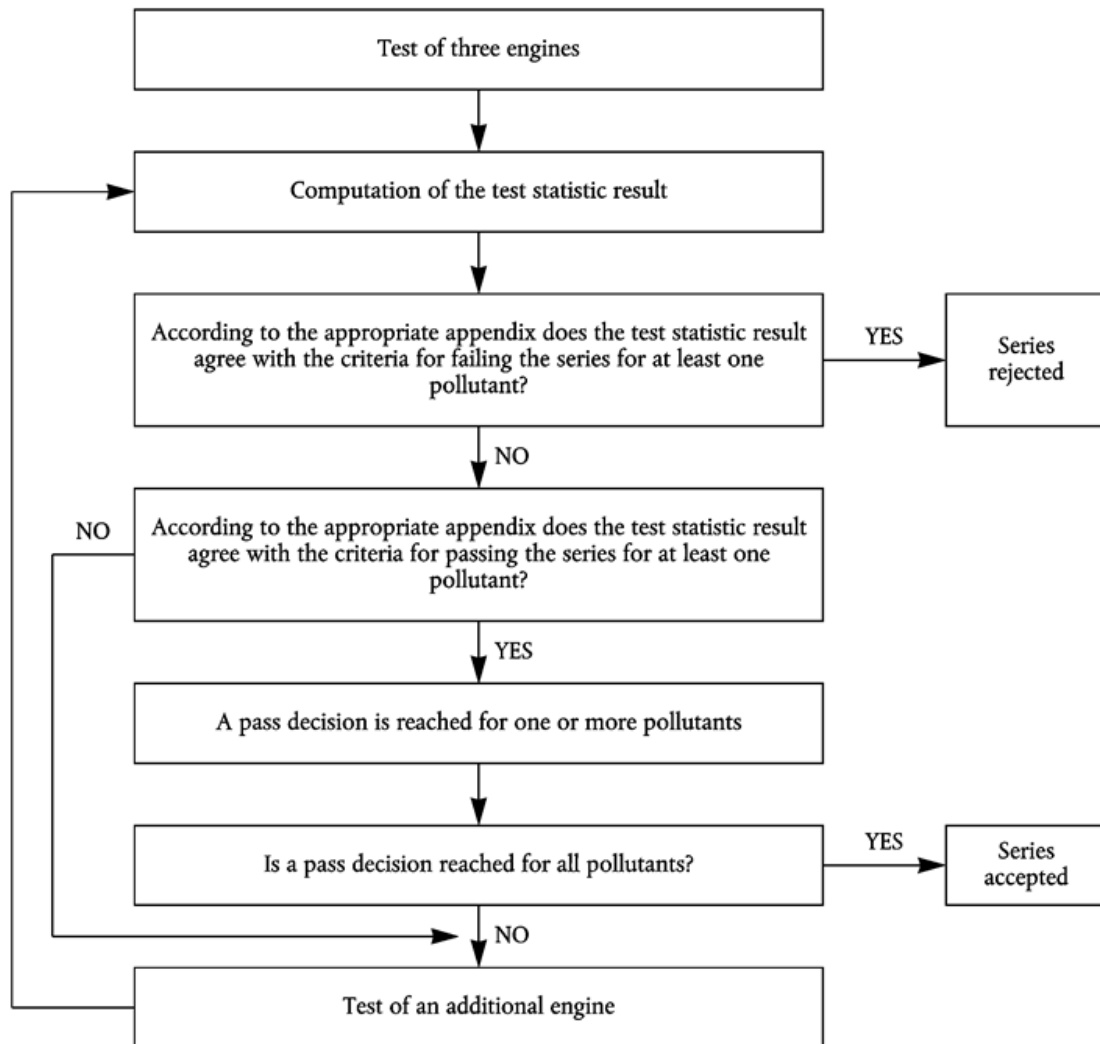

1. **Brief description**
- 1.1. Particulars to be completed in relation to the type-approval of a vehicle with an engine installed:
- 1.1.1. Make of engine (name of undertaking):
- 1.1.2. Type and commercial description (mention any variants):
- 1.1.3. Manufacturer's code as marked on the engine:
- 1.1.4. Category of vehicle (if applicable):
- 1.1.5. Category of engine: diesel/NG fuelled/LPG fuelled/ethanol fuelled ⁽¹⁾
- 1.1.6. Name and address of manufacturer:
- 1.1.7. Name and address of manufacturer's authorised representative (if any):
- 1.2. If the engine referred to in 1.1 has been type-approved as a separate technical unit:
- 1.2.1. Type-approval number of the engine/engine family ⁽¹⁾:
- 1.3. Particulars to be completed in relation to the type-approval of an engine/engine family ⁽¹⁾ as a separate technical unit (conditions to be respected in the installation of the engine on a vehicle):
- 1.3.1. Maximum and/or minimum intake depression: kPa
- 1.3.2. Maximum allowable back pressure: kPa
- 1.3.3. Exhaust system volume: cm³
- 1.3.4. Power absorbed by auxiliaries needed for operating the engine:
- 1.3.4.1. Idle: kW; Low speed: kW; High speed: kW
 Speed A: kW; Speed B: kW; Speed C: kW;
 Reference speed: kW
- 1.3.5. Restrictions of use (if any):
- 1.4. Emission levels of the engine/parent engine ⁽¹⁾
- 1.4.1. ESC-test (if applicable):
- CO: g/kWh
- THC: g/kWh
- NO_x: g/kWh
- PT: g/kWh
- 1.4.2. ELR-test (if applicable):
- Smoke value: m⁻¹
- 1.4.3. ETC-test (if applicable):
- CO: g/kWh
- THC: g/kWh ⁽¹⁾
- NMHC: g/kWh ⁽¹⁾
- CH₄: g/kWh ⁽¹⁾
- NO_x: g/kWh ⁽¹⁾
- PT: g/kWh ⁽¹⁾

Appendix 2

ESSENTIAL CHARACTERISTICS OF THE ENGINE FAMILY

EC TYPE-APPROVAL CERTIFICATE

Communication concerning the:

- type-approval ⁽¹⁾
- extension of type-approval ⁽¹⁾

of a type of a vehicle/separate technical unit (engine type/engine family)/component ⁽¹⁾ with regard to Directive 88/77/EEC

EC type-approval No: Extension No:

SECTION I

0. **General**

- 0.1. Make of vehicle/separate technical unit/component ⁽¹⁾:
- 0.2. Manufacturer's designation of vehicle type/separate technical unit (engine type/engine family)/component ⁽¹⁾:
- 0.3. Manufacturer's type coding as marked on the vehicle/separate technical unit (engine type/engine family)/component ⁽¹⁾:
- 0.4. Category of vehicle:
- 0.5. Category of engine: diesel/NG fuelled/LPG fuelled/ethanol fuelled ⁽¹⁾:
- 0.6. Name and address of manufacturer:
- 0.7. Name and address of manufacturer's authorised representative (if any):

SECTION II

1. Brief description (where appropriate): See Annex I.
2. Technical department responsible for carrying out the tests:
3. Date of test report:
4. Number of test report:
5. Ground(s) for extending type approval (where appropriate):
6. Remarks (if any): See Annex I.
7. Place:
8. Date:
9. Signature:
10. A list of documents making up the type-approval file lodged with the administrative department that has granted type approval, which may be obtained on request, is attached.

Status: This is the original version (as it was originally adopted).

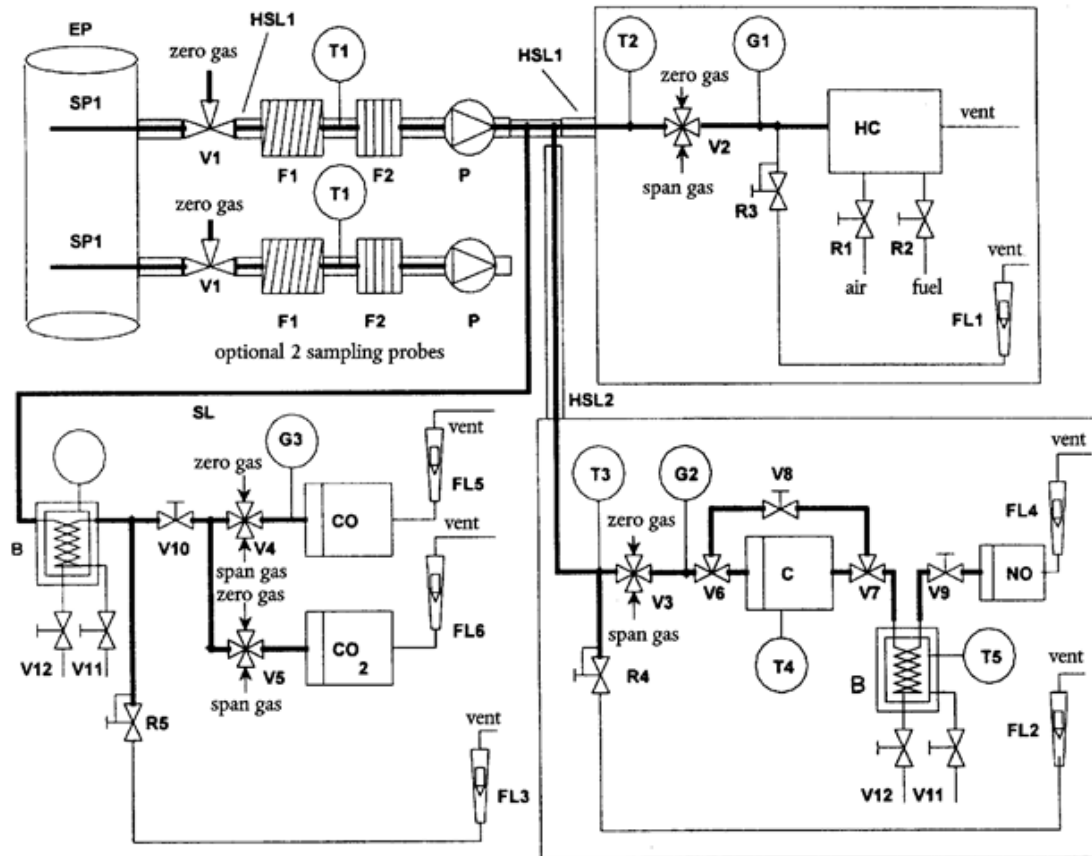

Appendix 3

ESSENTIAL CHARACTERISTICS OF THE ENGINE TYPE WITHIN THE FAMILY ⁽¹⁾

1. **Description of engine**
 - 1.1. Manufacturer:
 - 1.2. Manufacturer's engine code:
 - 1.3. Cycle: four stroke / two stroke ⁽²⁾:
 - 1.4. Number and arrangement of cylinders:
 - 1.4.1. Bore: mm
 - 1.4.2. Stroke: mm
 - 1.4.3. Firing order:
 - 1.5. Engine capacity: cm³
 - 1.6. Volumetric compression ratios ⁽³⁾:
 - 1.7. Drawing(s) of combustion chamber and piston crown:
 - 1.8. Minimum cross-sectional area of inlet and outlet ports: cm²
 - 1.9. Idling speed: min⁻¹
 - 1.10. Maximum net power: kW at min⁻¹
 - 1.11. Maximum permitted engine speed: min⁻¹
 - 1.12. Maximum net torque: Nm at min⁻¹
 - 1.13. Combustion system: compression ignition/positive ignition ⁽²⁾
 - 1.14. Fuel: Diesel/LPG/NG-H/NG-L/NG-HL/ethanol ⁽²⁾
 - 1.15. Cooling system
 - 1.15.1. Liquid
 - 1.15.1.1. Nature of liquid:
 - 1.15.1.2. Circulating pump(s): yes/no ⁽²⁾
 - 1.15.1.3. Characteristics or make(s) and type(s) (if applicable):
 - 1.15.1.4. Drive ratio(s) (if applicable):
 - 1.15.2. Air
 - 1.15.2.1. Blower: yes/no ⁽²⁾
 - 1.15.2.2. Characteristics or make(s) and type(s) (if applicable):
 - 1.15.2.3. Drive ratio(s) (if applicable):
 - 1.16. Temperature permitted by the manufacturer
 - 1.16.1. Liquid cooling: Maximum temperature at outlet: K
 - 1.16.2. Air cooling:
 - reference point:

⁽¹⁾ To be submitted for each engine of the family.⁽²⁾ Strike out what does not apply.⁽³⁾ Specify the tolerance.

Status: This is the original version (as it was originally adopted).

- Maximum temperature at reference point: K
- 1.16.3. Maximum temperature of the air at the outlet of the intake intercooler (if applicable): K
- 1.16.4. Maximum exhaust temperature at the point in the exhaust pipe(s) adjacent to the outer flange(s) of the exhaust manifold(s) or turbocharger(s): K
- 1.16.5. Fuel temperature: min. K, max. K
for diesel engines at injection pump inlet, for gas fuelled engines at pressure regulator final stage
- 1.16.6. Fuel pressure: min. kPa, max. kPa
at pressure regulator final stage, NG fuelled gas engines only
- 1.16.7. Lubricant temperature: min. K, max. K
- 1.17. Pressure charger: yes/no ⁽¹⁾
- 1.17.1. Make:
- 1.17.2. Type:
- 1.17.3. Description of the system (e.g. max. charge pressure, wastegate, if applicable):
.....
- 1.17.4. Intercooler: yes/no ⁽¹⁾
- 1.18. Intake system
Maximum allowable intake depression at rated engine speed and at 100 % load as specified in and under the operating conditions of Directive 80/1269/EEC:
..... kPa
- 1.19. Exhaust system
Maximum allowable exhaust back pressure at rated engine speed and at 100 % load as specified in and under the operating conditions of Directive 80/1269/EEC:
..... kPa
Exhaust system volume: dm³
2. **Measures taken against air pollution**
- 2.1. Device for recycling crankcase gases (description and drawings):
.....
- 2.2. Additional anti-pollution devices (if any, and if not covered by another heading)
- 2.2.1. Catalytic converter: yes/no ⁽¹⁾
- 2.2.1.1. Make(s):
- 2.2.1.2. Type(s):
- 2.2.1.3. Number of catalytic converters and elements:
- 2.2.1.4. Dimensions, shape and volume of the catalytic converter(s):
- 2.2.1.5. Type of catalytic action:
- 2.2.1.6. Total charge of precious metals:
- 2.2.1.7. Relative concentration:

⁽¹⁾ Strike out what does not apply.

2.2.1.8.	Substrate (structure and material):
2.2.1.9.	Cell density:
2.2.1.10.	Type of casing for the catalytic converter(s):
2.2.1.11.	Location of the catalytic converter(s) (place and reference distance in the exhaust line):
2.2.2.	Oxygen sensor: yes/no ⁽¹⁾
2.2.2.1.	Make(s):
2.2.2.2.	Type:
2.2.2.3.	Location:
2.2.3.	Air injection: yes/no ⁽¹⁾
2.2.3.1.	Type (pulse air, air pump, etc.):
2.2.4.	EGR: yes/no ⁽¹⁾
2.2.4.1.	Characteristics (flow rate etc.):
2.2.5.	Particulate trap: yes/no ⁽¹⁾
2.2.5.1.	Dimensions, shape and capacity of the particulate trap:
2.2.5.2.	Type and design of the particulate trap:
2.2.5.3.	Location (reference distance in the exhaust line):
2.2.5.4.	Method or system of regeneration, description and/or drawing:
2.2.6.	Other systems: yes/no ⁽¹⁾
2.2.6.1.	Description and operation:
3.	Fuel feed
3.1.	<i>Diesel engines</i>
3.1.1.	Feed pump
	Pressure ⁽²⁾ kPa or characteristic diagram ⁽¹⁾ :
3.1.2.	Injection system
3.1.2.1.	Pump
3.1.2.1.1.	Make(s):
3.1.2.1.2.	Type(s):
3.1.2.1.3.	Delivery: mm ³ ⁽²⁾ per stroke at engine speed of rpm at full injection, or characteristic diagram ⁽¹⁾ ⁽²⁾
	Mention the method used: on engine/on pump bench ⁽¹⁾
	If boost control is supplied, state the characteristic fuel delivery and boost pressure versus engine speed.
3.1.2.1.4.	Injection advance
3.1.2.1.4.1.	Injection advance curve ⁽²⁾ :
3.1.2.1.4.2.	Static injection timing ⁽²⁾ :
3.1.2.2.	Injection piping
3.1.2.2.1.	Length: mm
3.1.2.2.2.	Internal diameter: mm
3.1.2.3.	Injector(s)
3.1.2.3.1.	Make(s):
3.1.2.3.2.	Type(s):
3.1.2.3.3.	Opening pressure: kPa ⁽²⁾ or characteristic diagram ⁽¹⁾ ⁽²⁾ :

⁽¹⁾ Strike out what does not apply.

Status: This is the original version (as it was originally adopted).

- 3.1.2.4. Governor
 - 3.1.2.4.1. Make(s):
 - 3.1.2.4.2. Type(s):
 - 3.1.2.4.3. Speed at which cut-off starts under full load: rpm
 - 3.1.2.4.4. Maximum no-load speed: rpm
 - 3.1.2.4.5. Idling speed: rpm
- 3.1.3. Cold start system
 - 3.1.3.1. Make(s):
 - 3.1.3.2. Type(s):
 - 3.1.3.3. Description:
 - 3.1.3.4. Auxiliary starting aid:
 - 3.1.3.4.1. Make:
 - 3.1.3.4.2. Type:
- 3.2. Gas fuelled engines ⁽¹⁾
 - 3.2.1. Fuel: Natural gas/LPG ⁽²⁾
 - 3.2.2. Pressure regulator(s) or vaporiser/pressure regulator(s) ⁽³⁾
 - 3.2.2.1. Make(s):
 - 3.2.2.2. Type(s):
 - 3.2.2.3. Number of pressure reduction stages:
 - 3.2.2.4. Pressure in final stage: min. kPa, max. kPa
 - 3.2.2.5. Number of main adjustment points:
 - 3.2.2.6. Number of idle adjustment points:
 - 3.2.2.7. Certification number according to Directive 1999/96/EC:
 - 3.2.3. Fuelling system: mixing unit / gas injection / liquid injection / direct injection ⁽²⁾
 - 3.2.3.1. Mixture strength regulation:
 - 3.2.3.2. System description and/or diagram and drawings:
 - 3.2.3.3. Certification number according to Directive 1999/96/EC:
 - 3.2.4. Mixing unit
 - 3.2.4.1. Number:
 - 3.2.4.2. Make(s):
 - 3.2.4.3. Type(s):
 - 3.2.4.4. Location:
 - 3.2.4.5. Adjustment possibilities:
 - 3.2.4.6. Certification number according to Directive 1999/96/EC:
 - 3.2.5. Inlet manifold injection
 - 3.2.5.1. Injection: single point/multipoint ⁽²⁾
 - 3.2.5.2. Injection: continuous/simultaneously timed/sequentially timed ⁽²⁾
 - 3.2.5.3. Injection equipment

⁽¹⁾ In the case of systems laid-out in a different manner, supply equivalent information (for paragraph 3.2).

⁽²⁾ Strike out what does not apply.

⁽³⁾ Specify the tolerance.

- 3.2.5.3.1. Make(s):
- 3.2.5.3.2. Type(s):
- 3.2.5.3.3. Adjustment possibilities:
- 3.2.5.3.4. Certification number according to Directive 1999/96/EC:
- 3.2.5.4. Supply pump (if applicable):
- 3.2.5.4.1. Make(s):
- 3.2.5.4.2. Type(s):
- 3.2.5.4.3. Certification number according to Directive 1999/96/EC:
- 3.2.5.5. Injector(s):
- 3.2.5.5.1. Make(s):
- 3.2.5.5.2. Type(s):
- 3.2.5.5.3. Certification number according to Directive 1999/96/EC:
- 3.2.6. Direct injection
- 3.2.6.1. Injection pump / pressure regulator ⁽¹⁾
- 3.2.6.1.1. Make(s):
- 3.2.6.1.2. Type(s):
- 3.2.6.1.3. Injection timing:
- 3.2.6.1.4. Certification number according to Directive 1999/96/EC:
- 3.2.6.2. Injector(s)
- 3.2.6.2.1. Make(s):
- 3.2.6.2.2. Type(s):
- 3.2.6.2.3. Opening pressure or characteristic diagram ⁽²⁾:
- 3.2.6.2.4. Certification number according to Directive 1999/96/EC:
- 3.2.7. Electronic control unit (ECU)
- 3.2.7.1. Make(s):
- 3.2.7.2. Type(s):
- 3.2.7.3. Adjustment possibilities:
- 3.2.8. NG fuel-specific equipment
- 3.2.8.1. Variant 1
- (only in the case of approvals of engines for several specific fuel compositions)
- 3.2.8.1.1. Fuel composition:

methane (CH ₄):	basis:	%mole	min.	%mole	max.	%mole
ethane (C ₂ H ₆):	basis:	%mole	min.	%mole	max.	%mole
propane (C ₃ H ₈):	basis:	%mole	min.	%mole	max.	%mole
butane (C ₄ H ₁₀):	basis:	%mole	min.	%mole	max.	%mole
C5/C5+:	basis:	%mole	min.	%mole	max.	%mole
oxygen (O ₂):	basis:	%mole	min.	%mole	max.	%mole
inert (N ₂ , He etc.):	basis:	%mole	min.	%mole	max.	%mole

⁽¹⁾ Strike out what does not apply.

Status: This is the original version (as it was originally adopted).

- 3.2.8.1.2. Injector(s)
- 3.2.8.1.2.1. Make(s):
- 3.2.8.1.2.2. Type(s):
- 3.2.8.1.3. Others (if applicable)
- 3.2.8.2. Variant 2
(only in the case of approvals for several specific fuel compositions)
4. **Valve timing**
- 4.1. Maximum lift of valves and angles of opening and closing in relation to dead centres of equivalent data:
.....
- 4.2. Reference and/or setting ranges ⁽¹⁾:
5. **Ignition system (spark ignition engines only)**
- 5.1. Ignition system type: common coil and plugs/individual coil and plugs/coil on plug/other (specify) ⁽¹⁾
- 5.2. Ignition control unit
- 5.2.1. Make(s):
- 5.2.2. Type(s):
- 5.3. Ignition advance curve / advance map ⁽¹⁾ ⁽²⁾:
- 5.4. Ignition timing ⁽¹⁾: degrees before TDC at a speed of rpm and a MAP of kPa
- 5.5. Spark plugs
- 5.5.1. Make(s):
- 5.5.2. Type(s):
- 5.5.3. Gap setting: mm
- 5.6. Ignition coil(s)
- 5.6.1. Make(s):
- 5.6.2. Type(s):

⁽¹⁾ Strike out what does not apply.

Appendix 4

CHARACTERISTICS OF THE ENGINE-RELATED VEHICLE PARTS

8.3. Dynamometer settings (kW)

The dynamometer settings for the ESC and ELR tests and for the reference cycle of the ETC test shall be based upon the net engine power $P(n)$ of Section 8.2. It is recommended to install the engine on the test bed in the net condition. In this case, $P(m)$ and $P(n)$ are identical. If it is impossible or inappropriate to operate the engine under net conditions, the dynamometer settings shall be corrected to net conditions using the above formula.

8.3.1. ESC and ELR tests

The dynamometer settings shall be calculated according to the formula in Annex III, Appendix 1, Section 1.2.

Percent load	Engine speed			
	Idle	Speed A	Speed B	Speed C
10	—			
25	—			
50	—			
75	—			
100				

8.3.2. ETC test

If the engine is not tested under net conditions, the correction formula for converting the measured power or measured cycle work, as determined according to Annex III, Appendix 2, Section 2, to net power or net cycle work shall be submitted by the engine manufacturer for the whole operating area of the cycle, and approved by the Technical Service.

ANNEX III

TEST PROCEDURE

1. INTRODUCTION

1.1. This Annex describes the methods of determining emissions of gaseous components, particulates and smoke from the engines to be tested. Three test cycles are described that shall be applied according to the provisions of Annex I, Section 6.2:

- the ESC which consists of a steady state 13-mode cycle,
- the ELR which consists of transient load steps at different speeds, which are integral parts of one test procedure, and are run concurrently,
- the ETC which consists of a second-by-second sequence of transient modes.

1.2. The test shall be carried out with the engine mounted on a test bench and connected to a dynamometer.

1.3. Measurement principle

The emissions to be measured from the exhaust of the engine include the gaseous components (carbon monoxide, total hydrocarbons for diesel engines on the ESC test only; non-methane hydrocarbons for diesel and gas engines on the ETC test only; methane for gas engines on the ETC test only and oxides of nitrogen), the particulates (diesel engines only) and smoke (diesel engines on the ELR test only). Additionally, carbon dioxide is often used as a tracer gas for determining the dilution ratio of partial and full flow dilution systems. Good engineering practice recommends the general measurement of carbon dioxide as an excellent tool for the detection of measurement problems during the test run.

1.3.1. ESC test

During a prescribed sequence of warmed-up engine operating conditions the amounts of the above exhaust emissions shall be examined continuously by taking a sample from the raw exhaust gas. The test cycle consists of a number of speed and power modes which cover the typical operating range of diesel engines. During each mode the concentration of each gaseous pollutant, exhaust flow and power output shall be determined, and the measured values weighted. The particulate sample shall be diluted with conditioned ambient air. One sample over the complete test procedure shall be taken, and collected on suitable filters. The grams of each pollutant emitted per kilowatt hour shall be calculated as described in Appendix 1 to this Annex. Additionally, NO_x shall be measured at three test points within the control area selected by the Technical Service⁽¹⁴⁾ and the measured values compared to the values calculated from those modes of the test cycle enveloping the selected test points. The NO_x control check ensures the effectiveness of the emission control of the engine within the typical engine operating range.

1.3.2. ELR test

During a prescribed load response test, the smoke of a warmed-up engine shall be determined by means of an opacimeter. The test consists of loading the engine at constant speed from 10 % to 100 % load at three different engine speeds. Additionally, a fourth load step selected by the Technical Service⁽¹⁴⁾ shall be run, and the value compared to the values of the previous load steps. The smoke peak shall be determined using an averaging algorithm, as described in Appendix 1 to this Annex.

1.3.3. ETC test

During a prescribed transient cycle of warmed-up engine operating conditions, which is based closely on road-type-specific driving patterns of heavy-duty engines installed in trucks and buses, the above pollutants shall be examined after diluting the total exhaust gas with conditioned ambient air. Using the engine torque and speed feedback signals of the engine dynamometer, the power shall be integrated with respect to time of the cycle resulting in the work produced by the engine over the cycle. The concentration of NO_x and HC shall be determined over the cycle by integration of the analyser signal. The concentration of CO, CO₂, and NMHC may be determined by integration of the analyser signal or by bag sampling. For particulates, a proportional sample shall be collected on suitable filters. The diluted exhaust gas flow rate shall be determined over the cycle to calculate the mass emission values of the pollutants. The mass emission values shall be related to the engine work to get the grams of each pollutant emitted per kilowatt hour, as described in Appendix 2 to this Annex.

2. TEST CONDITIONS

2.1. Engine test conditions

2.1.1. The absolute temperature (T_a) of the engine air at the inlet to the engine expressed in Kelvin, and the dry atmospheric pressure (p_s), expressed in kPa shall be measured and the parameter F shall be determined according to the following provisions:

(a) for diesel engines:

Naturally aspirated and mechanically supercharged engines:

$$F = \left(\frac{p_p}{p_r}\right) \times \left(\frac{T_a}{298}\right)^{0,7}$$

Turbocharged engines with or without cooling of the intake air:

$$F = \left(\frac{p_p}{p_r}\right)^{0,7} \times \left(\frac{T_a}{298}\right)^{1,5}$$

(b) for gas engines:

$$F = \left(\frac{p_p}{p_r}\right)^{1,2} \times \left(\frac{T_a}{298}\right)^{0,6}$$

2.1.2. Test validity

For a test to be recognised as valid, the parameter F shall be such that:

$$0,96 \leq F \leq 1,06$$

2.2. Engines with charge air cooling

The charge air temperature shall be recorded and shall be, at the speed of the declared maximum power and full load, within ± 5 K of the maximum charge air temperature specified in Annex II, Appendix 1, Section 1.16.3. The temperature of the cooling medium shall be at least 293 K (20 °C).

If a test shop system or external blower is used, the charge air temperature shall be within ± 5 K of the maximum charge air temperature specified in Annex II, Appendix 1, Section 1.16.3 at the speed of the declared maximum power and full load. The setting of the charge air cooler for meeting the above conditions shall be used for the whole test cycle.

2.3. Engine air intake system

An engine air intake system shall be used presenting an air intake restriction within ± 100 Pa of the upper limit of the engine operating at the speed at the declared maximum power and full load.

2.4. Engine exhaust system

An exhaust system shall be used presenting an exhaust back pressure within $\pm 1\,000$ Pa of the upper limit of the engine operating at the speed of declared maximum power and full load and a volume within $\pm 40\%$ of that specified by the manufacturer. A test shop system may be used, provided it represents actual engine operating conditions. The exhaust system shall conform to the requirements for exhaust gas sampling, as set out in Annex III, Appendix 4, Section 3.4 and in Annex V, Section 2.2.1, EP and Section 2.3.1, EP.

If the engine is equipped with an exhaust aftertreatment device, the exhaust pipe must have the same diameter as found in-use for at least 4 pipe diameters upstream to the inlet of the beginning of the expansion section containing the aftertreatment device. The distance from the exhaust manifold flange or turbocharger outlet to the exhaust aftertreatment device shall be the same as in the vehicle configuration or within the distance specifications of the manufacturer. The exhaust backpressure or restriction shall follow the same criteria as above, and may be set with a valve. The aftertreatment container may be removed during dummy tests and during engine mapping, and replaced with an equivalent container having an inactive catalyst support.

2.5. Cooling system

An engine cooling system with sufficient capacity to maintain the engine at normal operating temperatures prescribed by the manufacturer shall be used.

2.6. Lubricating oil

Specifications of the lubricating oil used for the test shall be recorded and presented with the results of the test, as specified in Annex II, Appendix 1, Section 7.1.

2.7. Fuel

The fuel shall be the reference fuel specified in Annex IV.

The fuel temperature and measuring point shall be specified by the manufacturer within the limits given in Annex II, Appendix 1, Section 1.16.5. The fuel temperature shall not be lower than 306 K (33 °C). If not specified, it shall be 311 K \pm 5 K (38 °C \pm 5 °C) at the inlet to the fuel supply.

For NG and LPG fuelled engines, the fuel temperature and measuring point shall be within the limits given in Annex II, Appendix 1, Section 1.16.5 or in Annex II, Appendix 3, Section 1.16.5 in cases where the engine is not a parent engine.

2.8. Testing of exhaust aftertreatment systems

If the engine is equipped with an exhaust aftertreatment system, the emissions measured on the test cycle(s) shall be representative of the emissions in the field. If this cannot be achieved with one single test cycle (e.g. for particulate filters with periodic regeneration), several test cycles shall be conducted and the test results averaged and/or weighted. The exact procedure shall be agreed by the engine manufacturer and the Technical Service based upon good engineering judgement.

Appendix 1

ESC AND ELR TEST CYCLES

1. ENGINE AND DYNAMOMETER SETTINGS

1.1. Determination of engine speeds A, B and C

The engine speeds A, B and C shall be declared by the manufacturer in accordance with the following provisions:

The high speed n_{hi} shall be determined by calculating 70 % of the declared maximum net power $P(n)$, as determined in Annex II, Appendix 1, Section 8.2. The highest engine speed where this power value occurs on the power curve is defined as n_{hi} .

The low speed n_{lo} shall be determined by calculating 50 % of the declared maximum net power $P(n)$, as determined in Annex II, Appendix 1, Section 8.2. The lowest engine speed where this power value occurs on the power curve is defined as n_{lo} .

The engine speeds A, B and C shall be calculated as follows:

$$\text{Speed A} = n_{lo} + 25 \% (n_{hi} - n_{lo})$$

$$\text{Speed B} = n_{lo} + 50 \% (n_{hi} - n_{lo})$$

$$\text{Speed C} = n_{lo} + 75 \% (n_{hi} - n_{lo})$$

The engine speeds A, B and C may be verified by either of the following methods:

- (a) additional test points shall be measured during engine power approval according to Directive 80/1269/EEC for an accurate determination of n_{hi} and n_{lo} . The maximum power, n_{hi} and n_{lo} shall be determined from the power curve, and engine speeds A, B and C shall be calculated according to the above provisions;
- b) the engine shall be mapped along the full load curve, from maximum no load speed to idle speed, using at least 5 measurement points per 1 000 rpm intervals and measurement points within ± 50 rpm of the speed at declared maximum power. The maximum power, n_{hi} and n_{lo} shall be determined from this mapping curve, and engine speeds A, B and C shall be calculated according to the above provisions.

If the measured engine speeds A, B and C are within ± 3 % of the engine speeds as declared by the manufacturer, the declared engine speeds shall be used for the emissions test. If the tolerance is exceeded for any of the engine speeds, the measured engine speeds shall be used for the emissions test.

1.2. Determination of dynamometer settings

The torque curve at full load shall be determined by experimentation to calculate the torque values for the specified test modes under net conditions, as specified in Annex II, Appendix 1, Section 8.2. The power absorbed by engine-driven equipment, if applicable, shall be taken into account. The dynamometer setting for each test mode shall be calculated using the formula:

$$s = P(n) \times (L/100)$$

if tested under net conditions

$$s = P(n) \times (L/100) + (P(a) - P(b))$$

if not tested under net conditions

where:

s	= dynamometer setting, kW
P(n)	= net engine power as indicated in Annex II, Appendix 1, Section 8.2, kW
L	= per cent load as indicated in Section 2.7.1, %
P(a)	= power absorbed by auxiliaries to be fitted as indicated in Annex II, Appendix 1, Section 6.1
P(b)	= power absorbed by auxiliaries to be removed as indicated in Annex II, Appendix 1, Section 6.2

2. ESC TEST RUN

At the manufacturers request, a dummy test may be run for conditioning of the engine and exhaust system before the measurement cycle.

2.1. Preparation of the sampling filters

At least one hour before the test, each filter (pair) shall be placed in a closed, but unsealed petri dish and placed in a weighing chamber for stabilisation. At the end of the stabilisation period, each filter (pair) shall be weighed and the tare weight shall be recorded. The filter (pair) shall then be stored in a closed Petri dish or sealed filter holder until needed for testing. If the filter (pair) is not used within eight hours of its removal from the weighing chamber, it must be conditioned and reweighed before use.

2.2. Installation of the measuring equipment

The instrumentation and sample probes shall be installed as required. When using a full flow dilution system for exhaust gas dilution, the tailpipe shall be connected to the system.

2.3. Starting the dilution system and the engine

The dilution system and the engine shall be started and warmed up until all temperatures and pressures have stabilised at maximum power according to the recommendation of the manufacturer and good engineering practice.

2.4. Starting the particulate sampling system

The particulate sampling system shall be started and running on by-pass. The particulate background level of the dilution air may be determined by passing dilution air through the particulate filters. If filtered dilution air is used, one measurement may be done prior to or after the test. If the dilution air is not filtered, measurements at the beginning and at the end of the cycle, may be done, and the values averaged.

2.5. Adjustment of the dilution ratio

The dilution air shall be set such that the temperature of the diluted exhaust gas measured immediately prior to the primary filter shall not exceed 325 K (52 °C) at any mode. The dilution ratio (q) shall not be less than 4.

For systems that use CO₂ or NO_x concentration measurement for dilution ratio control, the CO₂ or NO_x content of the dilution air must be measured at the beginning and at the end of each test. The pre- and post-test background CO₂ or NO_x concentration measurements of the dilution air must be within 100 ppm or 5 ppm of each other, respectively.

2.6. Checking the analysers

The emission analysers shall be set at zero and spanned.

2.7. Test cycle

2.7.1. The following 13-mode cycle shall be followed in dynamometer operation on the test engine

Mode number	Engine speed	Percent load	Weighting factor	Mode length
1	idle	—	0,15	4 minutes
2	A	100	0,08	2 minutes
3	B	50	0,1	2 minutes
4	B	75	0,1	2 minutes
5	A	50	0,05	2 minutes
6	A	75	0,05	2 minutes
7	A	25	0,05	2 minutes
8	B	100	0,09	2 minutes
9	B	25	0,1	2 minutes
10	C	100	0,08	2 minutes
11	C	25	0,05	2 minutes
12	C	75	0,05	2 minutes
13	C	50	0,05	2 minutes

2.7.2. Test sequence

The test sequence shall be started. The test shall be performed in the order of the mode numbers as set out in Section 2.7.1.

The engine must be operated for the prescribed time in each mode, completing engine speed and load changes in the first 20 seconds. The specified speed shall be held to within ± 50 rpm and the specified torque shall be held to within $\pm 2\%$ of the maximum torque at the test speed.

At the manufacturers request, the test sequence may be repeated a sufficient number of times for sampling more particulate mass on the filter. The manufacturer shall supply a detailed description of the data evaluation and calculation procedures. The gaseous emissions shall only be determined on the first cycle.

2.7.3. Analyser response

The output of the analysers shall be recorded on a strip chart recorder or measured with an equivalent data acquisition system with the exhaust gas flowing through the analysers throughout the test cycle.

2.7.4. Particulate sampling

One pair of filters (primary and back-up filters, see Annex III, Appendix 4) shall be used for the complete test procedure. The modal weighting factors specified in the test cycle procedure shall be taken into account by taking a sample proportional to the exhaust mass flow during each individual mode of the cycle. This can be achieved by adjusting sample flow rate, sampling

time, and/or dilution ratio, accordingly, so that the criterion for the effective weighting factors in Section 5.6 is met.

The sampling time per mode must be at least 4 seconds per 0,01 weighting factor. Sampling must be conducted as late as possible within each mode. Particulate sampling shall be completed no earlier than 5 seconds before the end of each mode.

2.7.5. Engine conditions

The engine speed and load, intake air temperature and depression, exhaust temperature and backpressure, fuel flow and air or exhaust flow, charge air temperature, fuel temperature and humidity shall be recorded during each mode, with the speed and load requirements (see Section 2.7.2) being met during the time of particulate sampling, but in any case during the last minute of each mode.

Any additional data required for calculation shall be recorded (see Sections 4 and 5).

2.7.6. NO_x check within the control area

The NO_x check within the control area shall be performed immediately upon completion of mode 13.

The engine shall be conditioned at mode 13 for a period of three minutes before the start of the measurements. Three measurements shall be made at different locations within the control area, selected by the Technical Service⁽¹⁵⁾. The time for each measurement shall be 2 minutes.

The measurement procedure is identical to the NO_x measurement on the 13-mode cycle, and shall be carried out in accordance with Sections 2.7.3, 2.7.5, and 4.1 of this Appendix, and Annex III, Appendix 4, Section 3.

The calculation shall be carried out in accordance with Section 4.

2.7.7. Rechecking the analysers

After the emission test a zero gas and the same span gas shall be used for rechecking. The test will be considered acceptable if the difference between the pre-test and post-test results is less than 2 % of the span gas value.

3. ELR TEST RUN

3.1. Installation of the measuring equipment

The opacimeter and sample probes, if applicable, shall be installed after the exhaust silencer or any aftertreatment device, if fitted, according to the general installation procedures specified by the instrument manufacturer. Additionally, the requirements of Section 10 of ISO IDS 11614 shall be observed, where appropriate.

Prior to any zero and full scale checks, the opacimeter shall be warmed up and stabilised according to the instrument manufacturer's recommendations. If the opacimeter is equipped with a purge air system to prevent sooting of the meter optics, this system shall also be activated and adjusted according to the manufacturer's recommendations.

3.2. Checking of the opacimeter

The zero and full scale checks shall be made in the opacity readout mode, since the opacity scale offers two truly definable calibration points, namely 0 % opacity and 100 % opacity. The light absorption coefficient is then correctly calculated based upon the measured opacity and

the L_A , as submitted by the opacimeter manufacturer, when the instrument is returned to the k readout mode for testing.

With no blockage of the opacimeter light beam, the readout shall be adjusted to $0,0 \% \pm 1,0 \%$ opacity. With the light being prevented from reaching the receiver, the readout shall be adjusted to $100,0 \% \pm 1,0 \%$ opacity.

3.3. Test cycle

3.3.1. Conditioning of the engine

Warming up of the engine and the system shall be at maximum power in order to stabilise the engine parameters according to the recommendation of the manufacturer. The preconditioning phase should also protect the actual measurement against the influence of deposits in the exhaust system from a former test.

When the engine is stabilised, the cycle shall be started within 20 ± 2 s after the preconditioning phase. At the manufacturers request, a dummy test may be run for additional conditioning before the measurement cycle.

3.3.2. Test sequence

The test consists of a sequence of three load steps at each of the three engine speeds A (cycle 1), B (cycle 2) and C (cycle 3) determined in accordance with Annex III, Section 1.1, followed by cycle 4 at a speed within the control area and a load between 10 % and 100 %, selected by the Technical Service⁽¹⁶⁾. The following sequence shall be followed in dynamometer operation on the test engine, as shown in Figure 3.

6. Engine-driven equipment

The engine shall be submitted for testing with the auxiliaries needed for operating the engine (e.g. fan, water pump etc.), as specified in and under the operating conditions of Directive 80/1269/EEC, Annex I, Section 5.1.1.

6.1. Auxiliaries to be fitted for the test

If it is impossible or inappropriate to install the auxiliaries on the test bench, the power absorbed by them shall be determined and subtracted from the measured engine power over the whole operating area of the test cycle(s).

6.2. Auxiliaries to be removed for the test

Auxiliaries needed only for the operation of the vehicle (e.g. air compressor, air-conditioning system etc.) shall be removed for the test. Where the auxiliaries cannot be removed, the power absorbed by them may be determined and added to the measured engine power over the whole operating area of the test cycle(s).

7. Additional information on test conditions

7.1. Lubricant used

7.1.1. Make:

7.1.2. Type:

(State percentage of oil in mixture if lubricant and fuel are mixed):

7.2. Engine-driven equipment (if applicable)

The power absorbed by the auxiliaries needs only be determined:

- if auxiliaries needed for operating the engine are not fitted to the engine, and/or
- if auxiliaries not needed for operating the engine are fitted to the engine.

7.2.1. Enumeration and identifying details:

7.2.2. Power absorbed at various indicated engine speeds:

Equipment	Power absorbed (kW) at various engine speeds						
	Idle	Low speed	High speed	Speed A ⁽¹⁾	Speed B ⁽¹⁾	Speed C ⁽¹⁾	Ref. speed ⁽²⁾
P(a) Auxiliaries needed for operating the engine (to be subtracted from measured engine power) see Section 6.1.							
P(b) Auxiliaries not needed for operating the engine (to be added to measured engine power) see Section 6.2.							

⁽¹⁾ ESC test.

⁽²⁾ ETC test only.

- (a) The engine shall be operated at engine speed A and 10 per cent load for 20 ± 2 s. The specified speed shall be held to within ± 20 rpm and the specified torque shall be held to within ± 2 % of the maximum torque at the test speed.
- (b) At the end of the previous segment, the speed control lever shall be moved rapidly to, and held in, the wide open position for 10 ± 1 s. The necessary dynamometer load shall be applied to keep the engine speed within ± 150 rpm during the first 3 s, and within ± 20 rpm during the rest of the segment.
- (c) The sequence described in (a) and (b) shall be repeated two times.
- (d) Upon completion of the third load step, the engine shall be adjusted to engine speed B and 10 per cent load within 20 ± 2 s.
- (e) The sequence (a) to (c) shall be run with the engine operating at engine speed B.
- (f) Upon completion of the third load step, the engine shall be adjusted to engine speed C and 10 per cent load within 20 ± 2 s.
- (g) The sequence (a) to (c) shall be run with the engine operating at engine speed C.
- (h) Upon completion of the third load step, the engine shall be adjusted to the selected engine speed and any load above 10 per cent within 20 ± 2 s.
- (i) The sequence (a) to (c) shall be run with the engine operating at the selected engine speed.

3.4. Cycle validation

The relative standard deviations of the mean smoke values at each test speed (SV_A , SV_B , SV_C , as calculated in accordance with Section 6.3.3 of this Appendix from the three successive load steps at each test speed) shall be lower than 15 % of the mean value, or 10 % of the limit value shown in Table 1 of Annex I, whichever is greater. If the difference is greater, the sequence shall be repeated until three successive load steps meet the validation criteria.

3.5. Rechecking of the opacimeter

The post-test opacimeter zero drift value shall not exceed $\pm 5,0$ % of the limit value shown in Table 1 of Annex I.

4. CALCULATION OF THE GASEOUS EMISSIONS

4.1. Data evaluation

For the evaluation of the gaseous emissions, the chart reading of the last 30 seconds of each mode shall be averaged, and the average concentrations (conc) of HC, CO and NO_x during each mode shall be determined from the average chart readings and the corresponding calibration data. A different type of recording can be used if it ensures an equivalent data acquisition.

For the NO_x check within the control area, the above requirements apply for NO_x , only.

The exhaust gas flow G_{EXHW} or the diluted exhaust gas flow G_{TOTW} , if used optionally, shall be determined in accordance with Annex III, Appendix 4, Section 2.3.

4.2. Dry/wet correction

The measured concentration shall be converted to a wet basis according to the following formulae, if not already measured on a wet basis.

$$\text{conc(wet)} = K_w \times \text{conc(dry)}$$

Status: This is the original version (as it was originally adopted).

For the raw exhaust gas:

$$K_{W,r} = \left(1 - F_H \times \frac{G_{FUEL}}{G_{AIRD}}\right) - K_{W,2}$$

and,

$$F_{FH} = \frac{1,969}{\left(1 + \frac{G_{FUEL}}{G_{AIRW}}\right)}$$

For the diluted exhaust gas:

$$K_{W,e,1} = \left(1 - \frac{HTCRAT \times CO_2\%(wet)}{200}\right) - K_{W1}$$

or,

$$K_{W,e,2} = \left(\frac{1 - K_{W1}}{1 + \frac{HTCRAT \times CO_2\%(dry)}{200}}\right)$$

For the dilution air	For the intake air (if different from the dilution air)
$K_{W,d} = 1 - K_{W1}$	$K_{W,a} = 1 - K_{W2}$
$K_{W1} = \frac{1,608 \times H_d}{1000 + (1,608 \times H_d)}$	$K_{W2} = \frac{1,608 \times H_a}{1000 + (1,608 \times H_a)}$
$H_d = \frac{6,220 \times R_d \times p_d}{p_B - p_d \times R_d \times 10^{-2}}$	$H_a = \frac{6,220 \times R_a \times p_a}{p_B - p_a \times R_a \times 10^{-2}}$

where:

H_a, H_d	= g water per kg dry air
R_d, R_a	= relative humidity of the dilution/intake air, %
p_d, p_a	= saturation vapour pressure of the dilution/intake air, kPa
p_B	= total barometric pressure, kPa

4.3. NO_x correction for humidity and temperature

As the NO_x emission depends on ambient air conditions, the NO_x concentration shall be corrected for ambient air temperature and humidity with the factors given in the following formulae:

$$K_{HD} = \frac{1}{1 + A \times (H_a - 10,71) + B \times (T_a - 298)}$$

with:

A	= 0,309 G _{FUEL} /G _{AIRD} - 0,0266
B	= - 0,209 G _{FUEL} /G _{AIRD} + 0,00954
T _a	= temperature of the air, K
H _a	= humidity of the intake air, g water per kg dry air
H _a	= $\frac{6,220 \times R_a \times p_a}{p_B - p_a \times R_a \times 10^{-2}}$

in which

R _a	= relative humidity of the intake air, %
p _a	= saturation vapour pressure of the intake air, kPa
p _B	= total barometric pressure, kPa

4.4. Calculation of the emission mass flow rates

The emission mass flow rates (g/h) for each mode shall be calculated as follows, assuming the exhaust gas density to be 1,293 kg/m³ at 273 K (0 C) and 101,3 kPa:

$$\text{NO}_{x \text{ mass}} = 0,001587 \times \text{NO}_{x \text{ conc}} \times K_{H,D} \times G_{EXHW}$$

$$\text{CO}_{x \text{ mass}} = 0,000966 \times \text{CO}_{\text{conc}} \times G_{EXHW}$$

$$\text{HC}_{\text{mass}} = 0,000479 \times \text{HC}_{\text{conc}} \times G_{EXHW}$$

where $\text{NO}_{x \text{ conc}}$, CO_{conc} , HC_{conc} ⁽¹⁷⁾ are the average concentrations (ppm) in the raw exhaust gas, as determined in Section 4.1.

If, optionally, the gaseous emissions are determined with a full flow dilution system, the following formulae shall be applied:

$$\text{NO}_{x \text{ mass}} = 0,001587 \times \text{NO}_{x \text{ conc}} \times K_{H,D} \times G_{TOTW}$$

$$\text{CO}_{x \text{ mass}} = 0,000966 \times \text{CO}_{\text{conc}} \times G_{TOTW}$$

$$\text{HC}_{\text{mass}} = 0,000479 \times \text{HC}_{\text{conc}} \times G_{TOTW}$$

where $\text{NO}_{x \text{ conc}}$, CO_{conc} , HC_{conc} ⁽¹⁷⁾ are the average background corrected concentrations (ppm) of each mode in the diluted exhaust gas, as determined in Annex III, Appendix 2, Section 4.3.1.1.

4.5. Calculation of the specific emissions

The emissions (g/kWh) shall be calculated for all individual components in the following way:

$$\bar{\text{NO}}_x = \frac{\sum \text{NO}_{x \text{ mass}} \times \text{WF}_i}{\sum P(n)_i \times \text{WF}_i}$$

$$\bar{\text{CO}} = \frac{\sum \text{CO}_{\text{mass}} \times \text{WF}_i}{\sum P(n)_i \times \text{WF}_i}$$

$$\bar{\text{HC}} = \frac{\sum \text{HC}_{\text{mass}} \times \text{WF}_i}{\sum P(n)_i \times \text{WF}_i}$$

The weighting factors (WF) used in the above calculation are according to Section 2.7.1.

4.6. Calculation of the area control values

For the three control points selected according to Section 2.7.6, the NO_x emission shall be measured and calculated according to Section 4.6.1 and also determined by interpolation from the modes of the test cycle closest to the respective control point according to Section 4.6.2. The measured values are then compared to the interpolated values according to Section 4.6.3.

4.6.1. Calculation of the specific emission

The NO_x emission for each of the control points (Z) shall be calculated as follows:

$$\text{NO}_{x \text{ mass},Z} = 0,001587 \times \text{NO}_{x \text{ conc},Z} \times K_{H,D} \times G_{EXHW}$$

$$\text{NO}_{x,Z} = \frac{\text{NO}_{x \text{ mass},Z}}{P(n)_Z}$$

4.6.2. Determination of the emission value from the test cycle

The NO_x emission for each of the control points shall be interpolated from the four closest modes of the test cycle that envelop the selected control point Z as shown in Figure 4. For these modes (R, S, T, U), the following definitions apply:

$$\begin{aligned} \text{Speed(R)} &= \text{Speed(T)} = n_{RT} \\ \text{Speed(S)} &= \text{Speed(U)} = n_{SU} \\ \text{Per cent load(R)} &= \text{Per cent load(S)} \end{aligned}$$

Status: This is the original version (as it was originally adopted).

Per cent load(T) = Per cent load(U).

The NO_x emission of the selected control point Z shall be calculated as follows:

$$E_Z = \frac{E_{RS} + (E_{TU} - E_{RS}) \times (M_Z - M_{RS})}{M_{TU} - M_{RS}}$$

and:

$$E_{TU} = \frac{E_T + (E_U - E_T) \times (n_Z - n_{RT})}{n_{SU} - n_{RT}}$$

$$E_{RS} = \frac{E_R + (E_S - E_R) \times (n_Z - n_{RT})}{n_{SU} - n_{RT}}$$

$$M_{TU} = \frac{M_T + (M_U - M_T) \times (n_Z - n_{RT})}{n_{SU} - n_{RT}}$$

$$M_{RS} = \frac{M_R + (M_S - M_R) \times (n_Z - n_{RT})}{n_{SU} - n_{RT}}$$

where,

E_R, E_S, E_T, E_U = specific NO_x emission of the enveloping modes calculated in accordance with Section 4.6.1.

M_R, M_S, M_T, M_U = engine torque of the enveloping modes

Status: This is the original version (as it was originally adopted).

8. **Engine performance**

8.1. Engine speeds ⁽¹⁾

Low speed (n_{lo}): rpm

High speed (n_{hi}): rpm

for ESC and ELR cycles

Idle: rpm

Speed A: rpm

Speed B: rpm

Speed C: rpm

for ETC cycle

Reference speed: rpm

8.2. Engine power (measured in accordance with the provisions of Directive 80/1269/EEC) in kW

	Engine speed				
	Idle	Speed A ⁽¹⁾	Speed B ⁽¹⁾	Speed C ⁽¹⁾	Ref. speed ⁽²⁾
P(m) Power measured on test bed					
P(a) Power absorbed by auxiliaries to be fitted for test (Section 6.1) — if fitted — if not fitted	0	0	0	0	0
P(b) Power absorbed by auxiliaries to be removed for test (Section 6.2) — if fitted — if not fitted	0	0	0	0	0
P(n) Net engine power = P(m) – P(a) + P(b)					

⁽¹⁾ ESC test.

⁽²⁾ ETC test only.

4.6.3. Comparison of NO_x emission values

The measured specific NO_x emission of the control point Z (NO_{x,Z}) is compared to the interpolated value (E_Z) as follows:

$$NO_{x, diff} = 100 \times \frac{NO_{x,Z} - E_Z}{E_Z}$$

5. CALCULATION OF THE PARTICULATE EMISSION

5.1. Data evaluation

For the evaluation of the particulates, the total sample masses (M_{SAM,i}) through the filters shall be recorded for each mode.

The filters shall be returned to the weighing chamber and conditioned for at least one hour, but not more than 80 hours, and then weighed. The gross weight of the filters shall be recorded and the tare weight (see Section 1 of this Appendix) subtracted. The particulate mass M_f is the sum of the particulate masses collected on the primary and back-up filters.

If background correction is to be applied, the dilution air mass (M_{DIL}) through the filters and the particulate mass (M_d) shall be recorded. If more than one measurement was made, the quotient M_d/M_{DIL} must be calculated for each single measurement and the values averaged.

5.2. Partial flow dilution system

The final reported test results of the particulate emission shall be determined through the following steps. Since various types of dilution rate control may be used, different calculation methods for G_{EDFW} apply. All calculations shall be based upon the average values of the individual modes during the sampling period.

5.2.1. Isokinetic systems

$$G_{EDFW, j} = G_{EXH, j} \times q_i$$

$$q_i = \frac{G_{DIL, j} + (G_{EXH, j} \times r)}{G_{EXH, j} \times r}$$

where r corresponds to the ratio of the cross-sectional areas of the isokinetic probe and the exhaust pipe:

$$r = \frac{A_p}{A_T}$$

5.2.2. Systems with measurement of CO₂ or NO_x concentration

$$G_{EDFW, j} = G_{EXH, j} \times q_i$$

$$q_i = \frac{(conc_{E,j} - conc_{A,j})}{conc_{D,j} - conc_{A,j}}$$

where:

conc _E	=	wet concentration of the tracer gas in the raw exhaust
conc _D	=	wet concentration of the tracer gas in the diluted exhaust
conc _A	=	wet concentration of the tracer gas in the dilution air

Concentrations measured on a dry basis shall be converted to a wet basis according to Section 4.2 of this Appendix.

5.2.3. Systems with CO₂ measurement and carbon balance method⁽¹⁸⁾

$$G_{EDFW, j} = \frac{206,5 \times G_{FUEL, j}}{CO_{2, D, j} - CO_{2, A, j}}$$

where:

CO_{2D} = CO_2 concentration of the diluted exhaust

CO_{2A} = CO_2 concentration of the dilution air

(concentrations in vol % on wet basis)

This equation is based upon the carbon balance assumption (carbon atoms supplied to the engine are emitted as CO_2) and determined through the following steps:

$$G_{EDF\ W_j} = G_{EXH\ W_j} \times q_i$$

and

$$q_i = \frac{200,5 \times G_{FUEL_j}}{G_{EXH\ W_j} \times (CO_{2\ DJ} - CO_{2\ AJ})}$$

5.2.4. Systems with flow measurement

$$G_{EDF\ W_j} = G_{EXH\ W_j} \times q_i$$

$$q_i = \frac{G_{TOT\ W_j}}{G_{TOT\ W_j} - G_{DIL\ W_j}}$$

5.3. Full flow dilution system

The reported test results of the particulate emission shall be determined through the following steps. All calculations shall be based upon the average values of the individual modes during the sampling period.

$$G_{EDF\ W_j} = G_{TOT\ W_j}$$

5.4. Calculation of the particulate mass flow rate

The particulate mass flow rate shall be calculated as follows:

$$PT_{mass} = \frac{M_f}{M_{SAM}} \times \frac{\bar{G}_{EDF\ W}}{1000}$$

where

$$\bar{G}_{EDF\ W} = \sum_{i=1}^{i=n} G_{EDF\ W_j} \times WF_i$$

$$M_{SAM} = \sum_{i=1}^{i=n} M_{SAM,i}$$

$$i = 1, \dots, n$$

determined over the test cycle by summation of the average values of the individual modes during the sampling period.

The particulate mass flow rate may be background corrected as follows:

$$PT_{mass} = \left[M_f M_{SAM} \left(M_d M_{DIL} \times \left(\sum_{i=1}^{i=n} \left(1 - \frac{1}{DF_i} \right) \times WF_i \right) \right) \right] \times \frac{\bar{G}_{EDF\ W}}{1000}$$

If more than one measurement is made,

$$\frac{M_d}{M_{DIL}}$$

shall be replaced with

$$\frac{M_d}{\bar{M}_{DIL}}$$

.

$$DF_i = \frac{13,4}{(\text{conc}CO_2 + (\text{conc}CO + \text{conc}HC) \times 10^{-4})}$$

for the individual modes

or,

$$DF_i = \frac{13,4}{\text{concCO}_2}$$

for the individual modes.

5.5. Calculation of the specific emission

The particulate emission shall be calculated in the following way:

$$PT = \frac{PT_{\text{max}}}{\sum P(n)_i \times WF_i}$$

5.6. Effective weighting factor

The effective weighting factor $WF_{E,i}$ for each mode shall be calculated in the following way:

$$WF_{E,i} = \frac{M_{\text{SAM},i} \times G_{\text{EDF},i}}{M_{\text{SAM}} \times G_{\text{EDF},i}}$$

The value of the effective weighting factors shall be within $\pm 0,003$ ($\pm 0,005$ for the idle mode) of the weighting factors listed in Section 2.7.1.

6. CALCULATION OF THE SMOKE VALUES

6.1. Bessel algorithm

The Bessel algorithm shall be used to compute the 1 s average values from the instantaneous smoke readings, converted in accordance with Section 6.3.1. The algorithm emulates a low pass second order filter, and its use requires iterative calculations to determine the coefficients. These coefficients are a function of the response time of the opacimeter system and the sampling rate. Therefore, Section 6.1.1 must be repeated whenever the system response time and/or sampling rate changes.

6.1.1. Calculation of filter response time and Bessel constants

The required Bessel response time (t_F) is a function of the physical and electrical response times of the opacimeter system, as specified in Annex III, Appendix 4, Section 5.2.4, and shall be calculated by the following equation:

$$t_F = \sqrt{1 - (t_p^2 + t_e^2)}$$

where:

t_p = physical response time, s

t_e = electrical response time, s

The calculations for estimating the filter cut-off frequency (f_c) are based on a step input 0 to 1 in $\leq 0,01$ s (see Annex VII). The response time is defined as the time between when the Bessel output reaches 10 % (t_{10}) and when it reaches 90 % (t_{90}) of this step function. This must be obtained by iterating on f_c until $t_{90}-t_{10} \approx t_F$. The first iteration for f_c is given by the following formula:

$$f_c = \frac{\pi}{10 \times t_F}$$

The Bessel constants E and K shall be calculated by the following equations:

$$E = \frac{1}{(1 + \Omega \times \sqrt{(3 \times D) + D \times \Omega^2})}$$

$$K = 2 \times E \times (D \times \Omega^2 - 1) - 1$$

where:

$$\begin{aligned}
 D &= 0,618034 \\
 \Delta t &= \frac{1}{\text{sampling rate}} \\
 \Omega &= \frac{1}{|\tan(\pi \times \Delta t \times f_c)|}
 \end{aligned}$$

6.1.2. Calculation of the Bessel algorithm

Using the values of E and K, the 1 s Bessel averaged response to a step input S_i shall be calculated as follows:

$$Y_i = Y_{i-1} + E \times (S_i + 2 \times S_{i-1} + S_{i-2} - 4 \times Y_{i-2}) + K \times (Y_{i-1} - Y_{i-2})$$

where:

$$\begin{aligned}
 S_{i-2} &= S_{i-1} = 0 \\
 S_i &= 1 \\
 Y_{i-2} &= Y_{i-1} = 0
 \end{aligned}$$

The times t_{10} and t_{90} shall be interpolated. The difference in time between t_{90} and t_{10} defines the response time t_F for that value of f_c . If this response time is not close enough to the required response time, iteration shall be continued until the actual response time is within 1 % of the required response as follows:

$$((t_{90} - t_{10}) - t_F) \leq 0,01 \times t_F$$

6.2. Data evaluation

The smoke measurement values shall be sampled with a minimum rate of 20 Hz.

6.3. Determination of smoke

6.3.1. Data conversion

Since the basic measurement unit of all opacimeters is transmittance, the smoke values shall be converted from transmittance (τ) to the light absorption coefficient (k) as follows:

$$k = -\frac{1}{L_A} \times \ln\left(1 - \frac{N}{100}\right)$$

and

$$N = 100 - \tau$$

where:

$$\begin{aligned}
 k &= \text{light absorption coefficient, m}^{-1} \\
 L_A &= \text{effective optical path length, as submitted by instrument manufacturer, m} \\
 N &= \text{opacity, \%} \\
 \tau &= \text{transmittance, \%}
 \end{aligned}$$

The conversion shall be applied, before any further data processing is made.

6.3.2. Calculation of Bessel averaged smoke

The proper cut-off frequency f_c is the one that produces the required filter response time t_F . Once this frequency has been determined through the iterative process of Section 6.1.1, the proper Bessel algorithm constants E and K shall be calculated. The Bessel algorithm shall then be applied to the instantaneous smoke trace (k-value), as described in Section 6.1.2:

$$Y_i = Y_{i-1} + E \times (S_i + 2 \times S_{i-1} + S_{i-2} - 4 \times Y_{i-2}) + K \times (Y_{i-1} - Y_{i-2})$$

The Bessel algorithm is recursive in nature. Thus, it needs some initial input values of S_{i-1} and S_{i-2} and initial output values Y_{i-1} and Y_{i-2} to get the algorithm started. These may be assumed to be 0.

For each load step of the three speeds A, B and C, the maximum 1s value Y_{\max} shall be selected from the individual Y_i values of each smoke trace.

6.3.3. Final result

The mean smoke values (SV) from each cycle (test speed) shall be calculated as follows:

$$\text{For test speed A: } SV_A = (Y_{\max1,A} + Y_{\max2,A} + Y_{\max3,A}) / 3$$

$$\text{For test speed B: } SV_B = (Y_{\max1,B} + Y_{\max2,B} + Y_{\max3,B}) / 3$$

$$\text{For test speed C: } SV_C = (Y_{\max1,C} + Y_{\max2,C} + Y_{\max3,C}) / 3$$

where:

$Y_{\max1}, Y_{\max2}, Y_{\max3}$ = highest 1 s Bessel averaged smoke value at each of the three load steps

The final value shall be calculated as follows:

$$SV = (0,43 \times SV_A) + (0,56 \times SV_B) + (0,01 \times SV_C)$$

Appendix 2

ETC TEST CYCLE

1. ENGINE MAPPING PROCEDURE

1.1. Determination of the mapping speed range

For generating the ETC on the test cell, the engine needs to be mapped prior to the test cycle for determining the speed vs torque curve. The minimum and maximum mapping speeds are defined as follows:

Minimum mapping speed = idle speed

Maximum mapping speed = $n_{hi} \times 1,02$ or speed where full load torque drops off to zero, whichever is lower

1.2. Performing the engine power map

The engine shall be warmed up at maximum power in order to stabilise the engine parameters according to the recommendation of the manufacturer and good engineering practice. When the engine is stabilised, the engine map shall be performed as follows:

- (a) the engine shall be unloaded and operated at idle speed;
- (b) the engine shall be operated at full load setting of the injection pump at minimum mapping speed;
- (c) the engine speed shall be increased at an average rate of $8 \pm 1 \text{ min}^{-1} / \text{s}$ from minimum to maximum mapping speed. Engine speed and torque points shall be recorded at a sample rate of a least one point per second.

1.3. Mapping curve generation

All data points recorded under Section 1.2 shall be connected using linear interpolation between points. The resulting torque curve is the mapping curve and shall be used to convert the normalised torque values of the engine cycle into actual torque values for the test cycle, as described in Section 2.

1.4. Alternate mapping

If a manufacturer believes that the above mapping techniques are unsafe or unrepresentative for any given engine, alternate mapping techniques may be used. These alternate techniques must satisfy the intent of the specified mapping procedures to determine the maximum available torque at all engine speeds achieved during the test cycles. Deviations from the mapping techniques specified in this section for reasons of safety or representativeness shall be approved by the Technical Service along with the justification for their use. In no case, however, shall descending continual sweeps of engine speed be used for governed or turbocharged engines.

1.5. Replicate tests

An engine need not be mapped before each and every test cycle. An engine shall be remapped prior to a test cycle if:

- an unreasonable amount of time has transpired since the last map, as determined by engineering judgement,

or

- physical changes or recalibrations have been made to the engine which may potentially affect engine performance.

2. GENERATION OF THE REFERENCE TEST CYCLE

The transient test cycle is described in Appendix 3 to this Annex. The normalised values for torque and speed shall be changed to the actual values, as follows, resulting in the reference cycle.

2.1. Actual speed

The speed shall be unnormalised using the following equation:

$$\text{Actual speed} = \frac{\% \text{ speed}(\text{reference speed} - \text{idle speed})}{100} + \text{idle speed}$$

The reference speed (n_{ref}) corresponds to the 100 % speed values specified in the engine dynamometer schedule of Appendix 3. It is defined as follows (see Figure 1 of Annex I):

$$n_{\text{ref}} = n_{10} + 95 \% \times (n_{\text{hi}} - n_{10})$$

where n_{hi} and n_{10} are either specified according to Annex I, Section 2 or determined according to Annex III, Appendix 1, Section 1.1.

2.2. Actual torque

The torque is normalised to the maximum torque at the respective speed. The torque values of the reference cycle shall be unnormalised, using the mapping curve determined according to Section 1.3, as follows:

$$\text{Actual torque} = (\% \text{ torque} \times \text{max. torque}/100)$$

for the respective actual speed as determined in Section 2.1.

The negative torque values of the motoring points ('m') shall take on, for purposes of reference cycle generation, unnormalised values determined in either of the following ways:

- negative 40 % of the positive torque available at the associated speed point,
- mapping of the negative torque required to motor the engine from minimum to maximum mapping speed,
- determination of the negative torque required to motor the engine at idle and reference speeds and linear interpolation between these two points.

2.3. Example of the unnormalisation procedure

As an example, the following test point shall be unnormalised:

$$\begin{aligned} \% \text{ speed} &= 43 \\ \% \text{ torque} &= 82 \end{aligned}$$

Given the following values:

$$\begin{aligned} \text{reference speed} &= 2\,200 \text{ min}^{-1} \\ \text{idle speed} &= 600 \text{ min}^{-1} \end{aligned}$$

results in,

$$\text{actual speed} = (43 \times (2\,200 - 600)/100) + 600 = 1\,288 \text{ min}^{-1}$$

$$\text{actual torque} = (82 \times 700/100) = 574 \text{ Nm}$$

where the maximum torque observed from the mapping curve at 1 288 min⁻¹ is 700 Nm.

3. EMISSIONS TEST RUN

At the manufacturers request, a dummy test may be run for conditioning of the engine and exhaust system before the measurement cycle.

NG and LPG fuelled engines shall be run-in using the ETC test. The engine shall be run over a minimum of two ETC cycles and until the CO emission measured over one ETC cycle does not exceed by more than 10 % the CO emission measured over the previous ETC cycle.

3.1. Preparation of the sampling filters (diesel engines only)

At least one hour before the test, each filter (pair) shall be placed in a closed, but unsealed Petri dish and placed in a weighing chamber for stabilisation. At the end of the stabilisation period, each filter (pair) shall be weighed and the tare weight shall be recorded. The filter (pair) shall then be stored in a closed Petri dish or sealed filter holder until needed for testing. If the filter (pair) is not used within eight hours of its removal from the weighing chamber, it must be conditioned and reweighed before use.

3.2. Installation of the measuring equipment

The instrumentation and sample probes shall be installed as required. The tailpipe shall be connected to the full flow dilution system.

3.3. Starting the dilution system and the engine

The dilution system and the engine shall be started and warmed up until all temperatures and pressures have stabilised at maximum power according to the recommendation of the manufacturer and good engineering practice.

3.4. Starting the particulate sampling system (diesel engines only)

The particulate sampling system shall be started and running on by-pass. The particulate background level of the dilution air may be determined by passing dilution air through the particulate filters. If filtered dilution air is used, one measurement may be done prior to or after the test. If the dilution air is not filtered, measurements at the beginning and at the end of the cycle, may be done, and the values averaged.

3.5. Adjustment of the full flow dilution system

The total diluted exhaust gas flow shall be set to eliminate water condensation in the system, and to obtain a maximum filter face temperature of 325 K (52 °C) or less (see Annex V, Section 2.3.1, DT).

3.6. Checking the analysers

The emission analysers shall be set at zero and spanned. If sample bags are used, they shall be evacuated.

3.7. Engine starting procedure

The stabilised engine shall be started according to the manufacturer's recommended starting procedure in the owner's manual, using either a production starter motor or the dynamometer. Optionally, the test may start directly from the engine preconditioning phase without shutting the engine off, when the engine has reached the idle speed.

3.8. Test cycle

3.8.1. Test sequence

The test sequence shall be started, if the engine has reached idle speed. The test shall be performed according to the reference cycle as set out in Section 2 of this Appendix. Engine speed and torque command set points shall be issued at 5 Hz (10 Hz recommended) or greater. Feedback engine speed and torque shall be recorded at least once every second during the test cycle, and the signals may be electronically filtered.

3.8.2. Analyser response

At the start of the engine or test sequence, if the cycle is started directly from the preconditioning, the measuring equipment shall be started, simultaneously:

- start collecting or analysing dilution air;
- start collecting or analysing diluted exhaust gas;
- start measuring the amount of diluted exhaust gas (CVS) and the required temperatures and pressures;
- start recording the feedback data of speed and torque of the dynamometer.

HC and NO_x shall be measured continuously in the dilution tunnel with a frequency of 2 Hz. The average concentrations shall be determined by integrating the analyser signals over the test cycle. The system response time shall be no greater than 20 s, and shall be coordinated with CVS flow fluctuations and sampling time/test cycle offsets, if necessary. CO, CO₂, NMHC and CH₄ shall be determined by integration or by analysing the concentrations in the sample bag, collected over the cycle. The concentrations of the gaseous pollutants in the dilution air shall be determined by integration or by collecting into the background bag. All other values shall be recorded with a minimum of one measurement per second (1 Hz).

3.8.3. Particulate sampling (diesel engines only)

At the start of the engine or test sequence, if the cycle is started directly from the preconditioning, the particulate sampling system shall be switched from by-pass to collecting particulates.

If no flow compensation is used, the sample pump(s) shall be adjusted so that the flow rate through the particulate sample probe or transfer tube is maintained at a value within $\pm 5\%$ of the set flow rate. If flow compensation (i.e. proportional control of sample flow) is used, it must be demonstrated that the ratio of main tunnel flow to particulate sample flow does not change by more than $\pm 5\%$ of its set value (except for the first 10 seconds of sampling).

Note: For double dilution operation, sample flow is the net difference between the flow rate through the sample filters and the secondary dilution air flow rate.

The average temperature and pressure at the gas meter(s) or flow instrumentation inlet shall be recorded. If the set flow rate cannot be maintained over the complete cycle (within $\pm 5\%$) because of high particulate loading on the filter, the test shall be voided. The test shall be rerun using a lower flow rate and/or a larger diameter filter.

3.8.4. Engine stalling

If the engine stalls anywhere during the test cycle, the engine shall be preconditioned and restarted, and the test repeated. If a malfunction occurs in any of the required test equipment during the test cycle, the test shall be voided.

3.8.5. Operations after test

At the completion of the test, the measurement of the diluted exhaust gas volume, the gas flow into the collecting bags and the particulate sample pump shall be stopped. For an integrating analyser system, sampling shall continue until system response times have elapsed.

The concentrations of the collecting bags, if used, shall be analysed as soon as possible and in any case not later than 20 minutes after the end of the test cycle.

After the emission test, a zero gas and the same span gas shall be used for re-checking the analysers. The test will be considered acceptable if the difference between the pre-test and post-test results is less than 2 % of the span gas value.

For diesel engines only, the particulate filters shall be returned to the weighing chamber no later than one hour after completion of the test and shall be conditioned in a closed, but unsealed Petri dish for at least one hour, but not more than 80 hours before weighing.

3.9. Verification of the test run

3.9.1. Data shift

To minimise the biasing effect of the time lag between the feedback and reference cycle values, the entire engine speed and torque feedback signal sequence may be advanced or delayed in time with respect to the reference speed and torque sequence. If the feedback signals are shifted, both speed and torque must be shifted the same amount in the same direction.

3.9.2. Calculation of the cycle work

The actual cycle work W_{act} (kWh) shall be calculated using each pair of engine feedback speed and torque values recorded. This shall be done after any feedback data shift has occurred, if this option is selected. The actual cycle work W_{act} is used for comparison to the reference cycle work W_{ref} and for calculating the brake specific emissions (see Sections 4.4 and 5.2). The same methodology shall be used for integrating both reference and actual engine power. If values are to be determined between adjacent reference or adjacent measured values, linear interpolation shall be used.

In integrating the reference and actual cycle work, all negative torque values shall be set equal to zero and included. If integration is performed at a frequency of less than 5 Hertz, and if, during a given time segment, the torque value changes from positive to negative or negative to positive, the negative portion shall be computed and set equal to zero. The positive portion shall be included in the integrated value.

W_{act} shall be between - 15 % and + 5 % of W_{ref}

3.9.3. Validation statistics of the test cycle

Linear regressions of the feedback values on the reference values shall be performed for speed, torque and power. This shall be done after any feedback data shift has occurred, if this option is selected. The method of least squares shall be used, with the best fit equation having the form:

$$y = mx + b$$

where:

y	=	feedback (actual) value of speed (min^{-1}), torque (Nm), or power (kW)
m	=	slope of the regression line
x	=	reference value of speed (min^{-1}), torque (Nm), or power (kW)
b	=	y intercept of the regression line

Status: This is the original version (as it was originally adopted).

The standard error of estimate (SE) of y on x and the coefficient of determination (r^2) shall be calculated for each regression line.

It is recommended that this analysis be performed at 1 Hertz. All negative reference torque values and the associated feedback values shall be deleted from the calculation of cycle torque and power validation statistics. For a test to be considered valid, the criteria of Table 6 must be met.

TABLE 6

Regression line tolerances

	Speed	Torque	Power
Standard error of estimate (SE) of Y on X	Max 100 min ⁻¹	Max 13 % (15 %) ^a of power map maximum engine torque	Max 8 % (15 %) ^a of power map maximum engine power
Slope of the regression line, m	0,95 to 1,03	0,83–1,03	0,89–1,03 (0,83–1,03) ^a
Coefficient of determination, r^2	min 0,9700 (min 0,9500) ^a	min 0,8800 (min 0,7500) ^a	min 0,9100 (min 0,7500) ^a
Y intercept of the regression line, b	± 50 min ⁻¹	± 20 Nm or ± 2 % (± 20 Nm or ± 3 %) ^a of max torque whichever is greater	± 4 kW or ± 2 % (± 4 kW or ± 3 %) ^a of max power whichever is greater

^a Until 1 October 2005, the figures shown in brackets may be used for the type-approval testing of gas engines. The Commission shall report on the development of gas engine technology to confirm or modify the regression line tolerances applicable to gas engines given in this table.

Point deletions from the regression analyses are permitted where noted in Table 7.

TABLE 7

Permitted point deletions from regression analysis

Conditions	Points to be deleted
Full load and torque feedback < torque reference	Torque and/or power
No load, not an idle point, and torque feedback > torque reference	Torque and/or power
No load/closed throttle, idle point and speed > reference idle speed	Speed and/or power

4. CALCULATION OF THE GASEOUS EMISSIONS

4.1. Determination of the diluted exhaust gas flow

The total diluted exhaust gas flow over the cycle (kg/test) shall be calculated from the measurement values over the cycle and the corresponding calibration data of the flow measurement device (V_0 for PDP or K_V for CFV, as determined in Annex III, Appendix 5, Section 2). The following formulae shall be applied, if the temperature of the diluted exhaust

is kept constant over the cycle by using a heat exchanger (± 6 K for a PDP-CVS, ± 11 K for a CFV-CVS, see Annex V, Section 2.3).

For the PDP-CVS system:

$$M_{TOTW} = 1,293 \times V_0 \times N_p \times (p_B - p_1) \times 273 / (101,3 \times T)$$

where:

M_{TOTW}	= mass of the diluted exhaust gas on wet basis over the cycle, kg
V_0	= volume of gas pumped per revolution under test conditions, m^3/rev
N_p	= total revolutions of pump per test
p_B	= atmospheric pressure in the test cell, kPa
p_1	= pressure depression below atmospheric at pump inlet, kPa
T	= average temperature of the diluted exhaust gas at pump inlet over the cycle, K

For the CFV-CVS system:

$$M_{TOTW} = 1,293 \times t \times K_v \times p_A / T^{0,5}$$

where:

M_{TOTW}	= mass of the diluted exhaust gas on wet basis over the cycle, kg
t	= cycle time, s
K_v	= calibration coefficient of the critical flow venturi for standard conditions
p_A	= absolute pressure at venturi inlet, kPa
T	= absolute temperature at venturi inlet, K

If a system with flow compensation is used (i.e. without heat exchanger), the instantaneous mass emissions shall be calculated and integrated over the cycle. In this case, the instantaneous mass of the diluted exhaust gas shall be calculated as follows:

For the PDP-CVS system:

$$M_{TOTW,i} = 1,293 \times V_0 \times N_{p,i} \times (p_B - p_1) \times 273 / (101,3 \times T)$$

where:

$M_{TOTW,i}$	= instantaneous mass of the diluted exhaust gas on wet basis, kg
$N_{p,i}$	= total revolutions of pump per time interval

For the CFV-CVS system:

$$M_{TOTW,i} = 1,293 \times \Delta t_i \times K_v \times p_A / T^{0,5}$$

where:

$M_{TOTW,i}$	= instantaneous mass of the diluted exhaust gas on wet basis, kg
Δt_i	= time interval, s

If the total sample mass of particulates (M_{SAM}) and gaseous pollutants exceeds 0,5 % of the total CVS flow (M_{TOTW}), the CVS flow shall be corrected for M_{SAM} or the particulate sample flow shall be returned to the CVS prior to the flow measuring device (PDP or CFV).

4.2. NO_x correction for humidity

Status: This is the original version (as it was originally adopted).

As the NO_x emission depends on ambient air conditions, the NO_x concentration shall be corrected for ambient air humidity with the factors given in the following formulae:

(a) for diesel engines:

$$K_{H,D} = \frac{1}{1 - 0,0182 \times (H_a - 10,71)}$$

(b) for gas engines:

$$K_{H,G} = \frac{1}{1 - 0,0329 \times (H_a - 10,71)}$$

where:

H_a = humidity of the intake air water per kg dry air

in which:

$$H_a = \frac{6,220 \times R_a \times p_a}{p_B - p_a \times R_a \times 10^{-2}}$$

R_a = relative humidity of the intake air, %

p_a = saturation vapour pressure of the intake air, kPa

p_B = total barometric pressure, kPa

4.3. Calculation of the emission mass flow

4.3.1. Systems with constant mass flow

For systems with heat exchanger, the mass of the pollutants (g/test) shall be determined from the following equations:

$$NO_{x\ mass} = 0,001587 \times NO_{x\ conc} \times K_{H,D} \times M_{TOT\ W} \text{ (diesel engines)}$$

$$NO_{x\ mass} = 0,001587 \times NO_{x\ conc} \times K_{H,G} \times M_{TOT\ W} \text{ (gas engines)}$$

$$CO_{mass} = 0,000966 \times CO_{conc} \times M_{TOT\ W}$$

$$HC_{mass} = 0,000479 \times HC_{conc} \times M_{TOT\ W} \text{ (diesel engines)}$$

$$HC_{mass} = 0,000502 \times HC_{conc} \times M_{TOT\ W} \text{ (LPG fuelled engines)}$$

$$NMHC_{mass} = 0,000516 \times NMHC_{conc} \times M_{TOT\ W} \text{ (NG fuelled engines)}$$

$$CH_4\ mass = 0,000552 \times CH_4\ conc \times M_{TOT\ W} \text{ (NG fuelled engines)}$$

where:

NO_{x conc}, CO_{conc}, HC_{conc}⁽¹⁹⁾, NMHC_{conc} = average background corrected concentrations over the cycle from integration (mandatory for NO_x and HC) or bag measurement, ppm

M_{TOTW} = total mass of diluted exhaust gas over the cycle as determined in Section 4.1, kg

K_{H,D} = humidity correction factor for diesel engines as determined in Section 4.2

K_{H,G} = humidity correction factor for gas engines as determined in Section 4.2

Concentrations measured on a dry basis shall be converted to a wet basis in accordance with Annex III, Appendix 1, Section 4.2.

The determination of $NMHC_{conc}$ depends on the method used (see Annex III, Appendix 4, Section 3.3.4). In both cases, the CH_4 concentration shall be determined and subtracted from the HC concentration as follows:

(a) GC method

$$NMHC_{conc} = HC_{conc} - CH_4_{conc}$$

(b) NMC method

$$NMHC_{conc} = \frac{HC(w/o\ Cutter) \times (1 - CE_M) - HC(w\ Cutter)}{CE_E - CE_M}$$

where:

HC(wCutter) = HC concentration with the sample gas flowing through the NMC

HC(w/oCutter) = HC concentration with the sample gas bypassing the NMC

CE_M = methane efficiency as determined per Annex III, Appendix 5, Section 1.8.4.1

CE_E = ethane efficiency as determined per Annex III, Appendix 5, Section 1.8.4.2

4.3.1.1. Determination of the background corrected concentrations

The average background concentration of the gaseous pollutants in the dilution air shall be subtracted from measured concentrations to get the net concentrations of the pollutants. The average values of the background concentrations can be determined by the sample bag method or by continuous measurement with integration. The following formula shall be used.

$$conc = conc_e - conc_d \times \left(1 - \frac{1}{DF}\right)$$

where:

conc = concentration of the respective pollutant in the diluted exhaust gas, corrected by the amount of the respective pollutant contained in the dilution air, ppm

$conc_e$ = concentration of the respective pollutant measured in the diluted exhaust gas, ppm

$conc_d$ = concentration of the respective pollutant measured in the dilution air, ppm

DF = dilution factor

The dilution factor shall be calculated as follows:

(a) for diesel and LPG fuelled gas engines

$$DF = \frac{F_S}{CO_{2, conc\ e} + (HC_{conc\ e} + CO_{conc\ e}) \times 10^{-4}}$$

(b) for NG-fuelled gas engines

$$DF = \frac{F_S}{CO_{2, conc\ e} + (NMHC_{conc\ e} + CO_{conc\ e}) \times 10^{-4}}$$

where:

$CO_{2, conc}$ = concentration of CO_2 in the diluted exhaust gas, % vol

HC_{conc} = concentration of HC in the diluted exhaust gas, ppm C1

$NMHC_{conc}$ = concentration of NMHC in the diluted exhaust gas, ppm C1

CO_{conc} = concentration of CO in the diluted exhaust gas, ppm

F_S = stoichiometric factor

Status: This is the original version (as it was originally adopted).

Concentrations measured on dry basis shall be converted to a wet basis in accordance with Annex III, Appendix 1, Section 4.2.

The stoichiometric factor shall be calculated as follows:

$$F_S = 100 \times (\chi/\chi + (y/2) + 3,76 \times (\chi + (y/4)))$$

where:

x, y = fuel composition C_xH_y

Alternatively, if the fuel composition is not known, the following stoichiometric factors may be used:

$$F_S \text{ (diesel)} = 13,4$$

$$F_S \text{ (LPG)} = 11,6$$

$$F_S \text{ (NG)} = 9,5$$

4.3.2. Systems with flow compensation

For systems without heat exchanger, the mass of the pollutants (g/test) shall be determined by calculating the instantaneous mass emissions and integrating the instantaneous values over the cycle. Also, the background correction shall be applied directly to the instantaneous concentration value. The following formulae shall be applied:

$$NO_x \text{ mass} = \sum_{i=1}^n (M_{TOTW,i} \times NO_{x \text{ conce},i} \times 0,001587 \times K_{H,D}) - (M_{TOTW} \times NO_{x \text{ conced}} \times (1-1/DF) \times 0,001587 \times K_{H,D}) \text{ (diesel engines)}$$

$$NO_x \text{ mass} = \sum_{i=1}^n (M_{TOTW,i} \times NO_{x \text{ conce},i} \times 0,001587 \times K_{H,G}) - (M_{TOTW} \times NO_{x \text{ conced}} \times (1-1/DF) \times 0,001587 \times K_{H,G}) \text{ (gas engines)}$$

$$CO_{\text{mass}} = \sum_{i=1}^n (M_{TOTW,i} \times CO_{\text{conce},i} \times 0,000966) - (M_{TOTW} \times CO_{\text{conced}} \times (1-1/DF) \times 0,000966)$$

$$HC_{\text{mass}} = \sum_{i=1}^n (M_{TOTW,i} \times HC_{\text{conce},i} \times 0,000479) - (M_{TOTW} \times HC_{\text{conced}} \times (1-1/DF) \times 0,000479) \text{ (diesel engines)}$$

$$HC_{\text{mass}} = \sum_{i=1}^n (M_{TOTW,i} \times HC_{\text{conce},i} \times 0,000502) - (M_{TOTW} \times HC_{\text{conced}} \times (1-1/DF) \times 0,000502) \text{ (LPG engines)}$$

$$NMHC_{\text{mass}} = \sum_{i=1}^n (M_{TOTW,i} \times NMHC_{\text{conce},i} \times 0,000516) - (M_{TOTW} \times NMHC_{\text{conced}} \times (1-1/DF) \times 0,000516) \text{ (NG engines)}$$

$$CH_4 \text{ mass} = \sum_{i=1}^n (M_{TOTW,i} \times CH_4 \text{ conce},i \times 0,000552) - (M_{TOTW} \times CH_4 \text{ conced} \times (1-1/DF) \times 0,000552) \text{ (NG engines)}$$

where:

conc_e = concentration of the respective pollutant measured in the diluted exhaust gas, ppm

conc_d = concentration of the respective pollutant measured in the dilution air, ppm

M_{TOTW,i} = instantaneous mass of the diluted exhaust gas (see Section 4.1), kg

M_{TOTW} = total mass of diluted exhaust gas over the cycle (see Section 4.1), kg

K_{H,D} = humidity correction factor for diesel engines as determined in Section 4.2

K_{H,G} = humidity correction factor for gas engines as determined in Section 4.2

DF = dilution factor as determined in Section 4.3.1.1

4.4. Calculation of the specific emissions

The emissions (g/kWh) shall be calculated for all individual components in the following way:

$$\dot{NO}_x = \frac{NO_{x\ mass}}{W_{act}}$$

(diesel and gas engines)

$$\dot{CO} = \frac{CO_{mass}}{W_{act}}$$

(diesel and gas engines)

$$\dot{HC} = \frac{HC_{mass}}{W_{act}}$$

(diesel and LPG fuelled gas engines)

$$\dot{NMHC} = \frac{NMHC_{mass}}{W_{act}}$$

(NG fuelled gas engines)

$$\dot{CH}_4 = \frac{CH_4\ mass}{W_{act}}$$

(NG fuelled gas engines)

where:

W_{act} = actual cycle work as determined in Section 3.9.2, kWh

5. CALCULATION OF THE PARTICULATE EMISSION (DIESEL ENGINES ONLY)

5.1. Calculation of the mass flow

The particulate mass (g/test) shall be calculated as follows:

$$PT_{mass} = (M_f / M_{SAM}) \times (M_{TOTW} / 1\ 000)$$

where:

M_f = particulate mass sampled over the cycle, mg

M_{TOTW} = total mass of diluted exhaust gas over the cycle as determined in Section 4.1, kg

M_{SAM} = mass of diluted exhaust gas taken from the dilution tunnel for collecting particulates, kg

and:

M_f = $M_{f,p} + M_{f,b}$ if weighed separately, mg

$M_{f,p}$ = particulate mass collected on the primary filter, mg

$M_{f,b}$ = particulate mass collected on the back-up filter, mg

If a double dilution system is used, the mass of the secondary dilution air shall be subtracted from the total mass of the double diluted exhaust gas sampled through the particulate filters

$$M_{SAM} = M_{TOT} - M_{SEC}$$

where:

M_{TOT} = mass of double diluted exhaust gas through particulate filter, kg

M_{SEC} = mass of secondary dilution air, kg

If the particulate background level of the dilution air is determined in accordance with Section 3.4, the particulate mass may be background corrected. In this case, the particulate mass (g/test) shall be calculated as follows:

$$PT_{mass} = \left[M_f M_{SAM} \cdot \left(M_d M_{DIL} \times \left(1 - \frac{1}{DF} \right) \right) \right] \times M_{TOT} \text{ w } 1\ 000$$

where:

M_f, M_{SAM}, M_{TOTW} = see above

M_{DIL} = mass of primary dilution air sampled by background particulate sampler,
kg

M_d = mass of the collected background particulates of the primary dilution
air, mg

DF = dilution factor as determined in Section 4.3.1.1

5.2. Calculation of the specific emission

The particulate emission (g/kWh) shall be calculated in the following way:

$$PT = \frac{PT_{sam}}{W_{act}}$$

where:

W_{act} = actual cycle work as determined in Section 3.9.2, kWh.

Appendix 3

ETC ENGINE DYNAMOMETER SCHEDULE

Times	Normal speed%	Normal torque%
1	0	0
2	0	0
3	0	0
4	0	0
5	0	0
6	0	0
7	0	0
8	0	0
9	0	0
10	0	0
11	0	0
12	0	0
13	0	0
14	0	0
15	0	0
16	0,1	1,5
17	23,1	21,5
18	12,6	28,5
19	21,8	71
20	19,7	76,8
21	54,6	80,9
22	71,3	4,9
23	55,9	18,1
24	72	85,4
25	86,7	61,8
26	51,7	0
27	53,4	48,9
28	34,2	87,6
29	45,5	92,7
30	54,6	99,5

'm' = motoring.

Status: This is the original version (as it was originally adopted).

31	64,5	96,8
32	71,7	85,4
33	79,4	54,8
34	89,7	99,4
35	57,4	0
36	59,7	30,6
37	90,1	'm'
38	82,9	'm'
39	51,3	'm'
40	28,5	'm'
41	29,3	'm'
42	26,7	'm'
43	20,4	'm'
44	14,1	0
45	6,5	0
46	0	0
47	0	0
48	0	0
49	0	0
50	0	0
51	0	0
52	0	0
53	0	0
54	0	0
55	0	0
56	0	0
57	0	0
58	0	0
59	0	0
60	0	0
61	0	0
62	25,5	11,1
63	28,5	20,9
'm'	= motoring.	

Status: This is the original version (as it was originally adopted).

64	32	73,9
65	4	82,3
66	34,5	80,4
67	64,1	86
68	58	0
69	50,3	83,4
70	66,4	99,1
71	81,4	99,6
72	88,7	73,4
73	52,5	0
74	46,4	58,5
75	48,6	90,9
76	55,2	99,4
77	62,3	99
78	68,4	91,5
79	74,5	73,7
80	38	0
81	41,8	89,6
82	47,1	99,2
83	52,5	99,8
84	56,9	80,8
85	58,3	11,8
86	56,2	'm'
87	52	'm'
88	43,3	'm'
89	36,1	'm'
90	27,6	'm'
91	21,1	'm'
92	8	0
93	0	0
94	0	0
95	0	0
96	0	0
'm'	= motoring.	

Status: This is the original version (as it was originally adopted).

97	0	0
98	0	0
99	0	0
100	0	0
101	0	0
102	0	0
103	0	0
104	0	0
105	0	0
106	0	0
107	0	0
108	11,6	14,8
109	0	0
110	27,2	74,8
111	17	76,9
112	36	78
113	59,7	86
114	80,8	17,9
115	49,7	0
116	65,6	86
117	78,6	72,2
118	64,9	'm'
119	44,3	'm'
120	51,4	83,4
121	58,1	97
122	69,3	99,3
123	72	20,8
124	72,1	'm'
125	65,3	'm'
126	64	'm'
127	59,7	'm'
128	52,8	'm'
129	45,9	'm'
'm'	= motoring.	

Status: This is the original version (as it was originally adopted).

130	38,7	'm'
131	32,4	'm'
132	27	'm'
133	21,7	'm'
134	19,1	0,4
135	34,7	14
136	16,4	48,6
137	0	11,2
138	1,2	2,1
139	30,1	19,3
140	30	73,9
141	54,4	74,4
142	77,2	55,6
143	58,1	0
144	45	82,1
145	68,7	98,1
146	85,7	67,2
147	60,2	0
148	59,4	98
149	72,7	99,6
150	79,9	45
151	44,3	0
152	41,5	84,4
153	56,2	98,2
154	65,7	99,1
155	74,4	84,7
156	54,4	0
157	47,9	89,7
158	54,5	99,5
159	62,7	96,8
160	62,3	0
161	46,2	54,2
162	44,3	83,2
'm'	= motoring.	

Status: This is the original version (as it was originally adopted).

163	48,2	13,3
164	51	'm'
165	50	'm'
166	49,2	'm'
167	49,3	'm'
168	49,9	'm'
169	51,6	'm'
170	49,7	'm'
171	48,5	'm'
172	50,3	72,5
173	51,1	84,5
174	54,6	64,8
175	56,6	76,5
176	58	'm'
177	53,6	'm'
178	40,8	'm'
179	32,9	'm'
180	26,3	'm'
181	20,9	'm'
182	10	0
183	0	0
184	0	0
185	0	0
186	0	0
187	0	0
188	0	0
189	0	0
190	0	0
191	0	0
192	0	0
193	0	0
194	0	0
195	0	0
'm'	= motoring.	

Status: This is the original version (as it was originally adopted).

196	0	0
197	0	0
198	0	0
199	0	0
200	0	0
201	0	0
202	0	0
203	0	0
204	0	0
205	0	0
206	0	0
207	0	0
208	0	0
209	0	0
210	0	0
211	0	0
212	0	0
213	0	0
214	0	0
215	0	0
216	0	0
217	0	0
218	0	0
219	0	0
220	0	0
221	0	0
222	0	0
223	0	0
224	0	0
225	21,2	62,7
226	30,8	75,1
227	5,9	82,7
228	34,6	80,3
'm'	= motoring.	

Status: This is the original version (as it was originally adopted).

229	59,9	87
230	84,3	86,2
231	68,7	'm'
232	43,6	'm'
233	41,5	85,4
234	49,9	94,3
235	60,8	99
236	70,2	99,4
237	81,1	92,4
238	49,2	0
239	56	86,2
240	56,2	99,3
241	61,7	99
242	69,2	99,3
243	74,1	99,8
244	72,4	8,4
245	71,3	0
246	71,2	9,1
247	67,1	'm'
248	65,5	'm'
249	64,4	'm'
250	62,9	25,6
251	62,2	35,6
252	62,9	24,4
253	58,8	'm'
254	56,9	'm'
255	54,5	'm'
256	51,7	17
257	56,2	78,7
258	59,5	94,7
259	65,5	99,1
260	71,2	99,5
261	76,6	99,9
'm'	= motoring.	

Status: This is the original version (as it was originally adopted).

262	79	0
263	52,9	97,5
264	53,1	99,7
265	59	99,1
266	62,2	99
267	65	99,1
268	69	83,1
269	69,9	28,4
270	70,6	12,5
271	68,9	8,4
272	69,8	9,1
273	69,6	7
274	65,7	'm'
275	67,1	'm'
276	66,7	'm'
277	65,6	'm'
278	64,5	'm'
279	62,9	'm'
280	59,3	'm'
281	54,1	'm'
282	51,3	'm'
283	47,9	'm'
284	43,6	'm'
285	39,4	'm'
286	34,7	'm'
287	29,8	'm'
288	20,9	73,4
289	36,9	'm'
290	35,5	'm'
291	20,9	'm'
292	49,7	11,9
293	42,5	'm'
294	32	'm'
'm'	= motoring.	

Status: This is the original version (as it was originally adopted).

295	23,6	'm'
296	19,1	0
297	15,7	73,5
298	25,1	76,8
299	34,5	81,4
300	44,1	87,4
301	52,8	98,6
302	63,6	99
303	73,6	99,7
304	62,2	'm'
305	29,2	'm'
306	46,4	22
307	47,3	13,8
308	47,2	12,5
309	47,9	11,5
310	47,8	35,5
311	49,2	83,3
312	52,7	96,4
313	57,4	99,2
314	61,8	99
315	66,4	60,9
316	65,8	'm'
317	59	'm'
318	50,7	'm'
319	41,8	'm'
320	34,7	'm'
321	28,7	'm'
322	25,2	'm'
323	43	24,8
324	38,7	0
325	48,1	31,9
326	40,3	61
327	42,4	52,1
'm'	= motoring.	

Status: This is the original version (as it was originally adopted).

328	46,4	47,7
329	46,9	30,7
330	46,1	23,1
331	45,7	23,2
332	45,5	31,9
333	46,4	73,6
334	51,3	60,7
335	51,3	51,1
336	53,2	46,8
337	53,9	50
338	53,4	52,1
339	53,8	45,7
340	50,6	22,1
341	47,8	26
342	41,6	17,8
343	38,7	29,8
344	35,9	71,6
345	34,6	47,3
346	34,8	80,3
347	35,9	87,2
348	38,8	90,8
349	41,5	94,7
350	47,1	99,2
351	53,1	99,7
352	46,4	0
353	42,5	0,7
354	43,6	58,6
355	47,1	87,5
356	54,1	99,5
357	62,9	99
358	72,6	99,6
359	82,4	99,5
360	88	99,4
'm'	= motoring.	

Status: This is the original version (as it was originally adopted).

361	46,4	0
362	53,4	95,2
363	58,4	99,2
364	61,5	99
365	64,8	99
366	68,1	99,2
367	73,4	99,7
368	73,3	29,8
369	73,5	14,6
370	68,3	0
371	45,4	49,9
372	47,2	75,7
373	44,5	9
374	47,8	10,3
375	46,8	15,9
376	46,9	12,7
377	46,8	8,9
378	46,1	6,2
379	46,1	'm'
380	45,5	'm'
381	44,7	'm'
382	43,8	'm'
383	41	'm'
384	41,1	6,4
385	38	6,3
386	35,9	0,3
387	33,5	0
388	53,1	48,9
389	48,3	'm'
390	49,9	'm'
391	48	'm'
392	45,3	'm'
393	41,6	3,1
'm'	= motoring.	

Status: This is the original version (as it was originally adopted).

394	44,3	79
395	44,3	89,5
396	43,4	98,8
397	44,3	98,9
398	43	98,8
399	42,2	98,8
400	42,7	98,8
401	45	99
402	43,6	98,9
403	42,2	98,8
404	44,8	99
405	43,4	98,8
406	45	99
407	42,2	54,3
408	61,2	31,9
409	56,3	72,3
410	59,7	99,1
411	62,3	99
412	67,9	99,2
413	69,5	99,3
414	73,1	99,7
415	77,7	99,8
416	79,7	99,7
417	82,5	99,5
418	85,3	99,4
419	86,6	99,4
420	89,4	99,4
421	62,2	0
422	52,7	96,4
423	50,2	99,8
424	49,3	99,6
425	52,2	99,8
426	51,3	100
'm'	= motoring.	

Status: This is the original version (as it was originally adopted).

427	51,3	100
428	51,1	100
429	51,1	100
430	51,8	99,9
431	51,3	100
432	51,1	100
433	51,3	100
434	52,3	99,8
435	52,9	99,7
436	53,8	99,6
437	51,7	99,9
438	53,5	99,6
439	52	99,8
440	51,7	99,9
441	53,2	99,7
442	54,2	99,5
443	55,2	99,4
444	53,8	99,6
445	53,1	99,7
446	55	99,4
447	57	99,2
448	61,5	99
449	59,4	5,7
450	59	0
451	57,3	59,8
452	64,1	99
453	70,9	90,5
454	58	0
455	41,5	59,8
456	44,1	92,6
457	46,8	99,2
458	47,2	99,3
459	51	100
'm'	= motoring.	

Status: This is the original version (as it was originally adopted).

460	53,2	99,7
461	53,1	99,7
462	55,9	53,1
463	53,9	13,9
464	52,5	'm'
465	51,7	'm'
466	51,5	52,2
467	52,8	80
468	54,9	95
469	57,3	99,2
470	60,7	99,1
471	62,4	'm'
472	60,1	'm'
473	53,2	'm'
474	44	'm'
475	35,2	'm'
476	30,5	'm'
477	26,5	'm'
478	22,5	'm'
479	20,4	'm'
480	19,1	'm'
481	19,1	'm'
482	13,4	'm'
483	6,7	'm'
484	3,2	'm'
485	14,3	63,8
486	34,1	0
487	23,9	75,7
488	31,7	79,2
489	32,1	19,4
490	35,9	5,8
491	36,6	0,8
492	38,7	'm'
'm'	= motoring.	

Status: This is the original version (as it was originally adopted).

493	38,4	'm'
494	39,4	'm'
495	39,7	'm'
496	40,5	'm'
497	40,8	'm'
498	39,7	'm'
499	39,2	'm'
500	38,7	'm'
501	32,7	'm'
502	30,1	'm'
503	21,9	'm'
504	12,8	0
505	0	0
506	0	0
507	0	0
508	0	0
509	0	0
510	0	0
511	0	0
512	0	0
513	0	0
514	30,5	25,6
515	19,7	56,9
516	16,3	45,1
517	27,2	4,6
518	21,7	1,3
519	29,7	28,6
520	36,6	73,7
521	61,3	59,5
522	40,8	0
523	36,6	27,8
524	39,4	80,4
525	51,3	88,9
'm'	= motoring.	

Status: This is the original version (as it was originally adopted).

526	58,5	11,1
527	60,7	'm'
528	54,5	'm'
529	51,3	'm'
530	45,5	'm'
531	40,8	'm'
532	38,9	'm'
533	36,6	'm'
534	36,1	72,7
535	44,8	78,9
536	51,6	91,1
537	59,1	99,1
538	66	99,1
539	75,1	99,9
540	81	8
541	39,1	0
542	53,8	89,7
543	59,7	99,1
544	64,8	99
545	70,6	96,1
546	72,6	19,6
547	72	6,3
548	68,9	0,1
549	67,7	'm'
550	66,8	'm'
551	64,3	16,9
552	64,9	7
553	63,6	12,5
554	63	7,7
555	64,4	38,2
556	63	11,8
557	63,6	0
558	63,3	5
'm'	= motoring.	

Status: This is the original version (as it was originally adopted).

559	60,1	9,1
560	61	8,4
561	59,7	0,9
562	58,7	'm'
563	56	'm'
564	53,9	'm'
565	52,1	'm'
566	49,9	'm'
567	46,4	'm'
568	43,6	'm'
569	40,8	'm'
570	37,5	'm'
571	27,8	'm'
572	17,1	0,6
573	12,2	0,9
574	11,5	1,1
575	8,7	0,5
576	8	0,9
577	5,3	0,2
578	4	0
579	3,9	0
580	0	0
581	0	0
582	0	0
583	0	0
584	0	0
585	0	0
586	0	0
587	8,7	22,8
588	16,2	49,4
589	23,6	56
590	21,1	56,1
591	23,6	56
'm'	= motoring.	

Status: This is the original version (as it was originally adopted).

592	46,2	68,8
593	68,4	61,2
594	58,7	'm'
595	31,6	'm'
596	19,9	8,8
597	32,9	70,2
598	43	79
599	57,4	98,9
600	72,1	73,8
601	53	0
602	48,1	86
603	56,2	99
604	65,4	98,9
605	72,9	99,7
606	67,5	'm'
607	39	'm'
608	41,9	38,1
609	44,1	80,4
610	46,8	99,4
611	48,7	99,9
612	50,5	99,7
613	52,5	90,3
614	51	1,8
615	50	'm'
616	49,1	'm'
617	47	'm'
618	43,1	'm'
619	39,2	'm'
620	40,6	0,5
621	41,8	53,4
622	44,4	65,1
623	48,1	67,8
624	53,8	99,2
'm'	= motoring.	

Status: This is the original version (as it was originally adopted).

625	58,6	98,9
626	63,6	98,8
627	68,5	99,2
628	72,2	89,4
629	77,1	0
630	57,8	79,1
631	60,3	98,8
632	61,9	98,8
633	63,8	98,8
634	64,7	98,9
635	65,4	46,5
636	65,7	44,5
637	65,6	3,5
638	49,1	0
639	50,4	73,1
640	50,5	'm'
641	51	'm'
642	49,4	'm'
643	49,2	'm'
644	48,6	'm'
645	47,5	'm'
646	46,5	'm'
647	46	11,3
648	45,6	42,8
649	47,1	83
650	46,2	99,3
651	47,9	99,7
652	49,5	99,9
653	50,6	99,7
654	51	99,6
655	53	99,3
656	54,9	99,1
657	55,7	99
'm'	= motoring.	

Status: This is the original version (as it was originally adopted).

658	56	99
659	56,1	9,3
660	55,6	'm'
661	55,4	'm'
662	54,9	51,3
663	54,9	59,8
664	54	39,3
665	53,8	'm'
666	52	'm'
667	50,4	'm'
668	50,6	0
669	49,3	41,7
670	50	73,2
671	50,4	99,7
672	51,9	99,5
673	53,6	99,3
674	54,6	99,1
675	56	99
676	55,8	99
677	58,4	98,9
678	59,9	98,8
679	60,9	98,8
680	63	98,8
681	64,3	98,9
682	64,8	64
683	65,9	46,5
684	66,2	28,7
685	65,2	1,8
686	65	6,8
687	63,6	53,6
688	62,4	82,5
689	61,8	98,8
690	59,8	98,8
'm'	= motoring.	

Status: This is the original version (as it was originally adopted).

691	59,2	98,8
692	59,7	98,8
693	61,2	98,8
694	62,2	49,4
695	62,8	37,2
696	63,5	46,3
697	64,7	72,3
698	64,7	72,3
699	65,4	77,4
700	66,1	69,3
701	64,3	'm'
702	64,3	'm'
703	63	'm'
704	62,2	'm'
705	61,6	'm'
706	62,4	'm'
707	62,2	'm'
708	61	'm'
709	58,7	'm'
710	55,5	'm'
711	51,7	'm'
712	49,2	'm'
713	48,8	40,4
714	47,9	'm'
715	46,2	'm'
716	45,6	9,8
717	45,6	34,5
718	45,5	37,1
719	43,8	'm'
720	41,9	'm'
721	41,3	'm'
722	41,4	'm'
723	41,2	'm'
'm'	= motoring.	

Status: This is the original version (as it was originally adopted).

724	41,8	'm'
725	41,8	'm'
726	43,2	17,4
727	45	29
728	44,2	'm'
729	43,9	'm'
730	38	10,7
731	56,8	'm'
732	57,1	'm'
733	52	'm'
734	44,4	'm'
735	40,2	'm'
736	39,2	16,5
737	38,9	73,2
738	39,9	89,8
739	42,3	98,6
740	43,7	98,8
741	45,5	99,1
742	45,6	99,2
743	48,1	99,7
744	49	100
745	49,8	99,9
746	49,8	99,9
747	51,9	99,5
748	52,3	99,4
749	53,3	99,3
750	52,9	99,3
751	54,3	99,2
752	55,5	99,1
753	56,7	99
754	61,7	98,8
755	64,3	47,4
756	64,7	1,8
'm'	= motoring.	

Status: This is the original version (as it was originally adopted).

757	66,2	'm'
758	49,1	'm'
759	52,1	46
760	52,6	61
761	52,9	0
762	52,3	20,4
763	54,2	56,7
764	55,4	59,8
765	56,1	49,2
766	56,8	33,7
767	57,2	96
768	58,6	98,9
769	59,5	98,8
770	61,2	98,8
771	62,1	98,8
772	62,7	98,8
773	62,8	98,8
774	64	98,9
775	63,2	46,3
776	62,4	'm'
777	60,3	'm'
778	58,7	'm'
779	57,2	'm'
780	56,1	'm'
781	56	9,3
782	55,2	26,3
783	54,8	42,8
784	55,7	47,1
785	56,6	52,4
786	58	50,3
787	58,6	20,6
788	58,7	'm'
789	59,3	'm'
'm'	= motoring.	

Status: This is the original version (as it was originally adopted).

790	58,6	'm'
791	60,5	9,7
792	59,2	9,6
793	59,9	9,6
794	59,6	9,6
795	59,9	6,2
796	59,9	9,6
797	60,5	13,1
798	60,3	20,7
799	59,9	31
800	60,5	42
801	61,5	52,5
802	60,9	51,4
803	61,2	57,7
804	62,8	98,8
805	63,4	96,1
806	64,6	45,4
807	64,1	5
808	63	3,2
809	62,7	14,9
810	63,5	35,8
811	64,1	73,3
812	64,3	37,4
813	64,1	21
814	63,7	21
815	62,9	18
816	62,4	32,7
817	61,7	46,2
818	59,8	45,1
819	57,4	43,9
820	54,8	42,8
821	54,3	65,2
822	52,9	62,1
'm'	= motoring.	

Status: This is the original version (as it was originally adopted).

823	52,4	30,6
824	50,4	'm'
825	48,6	'm'
826	47,9	'm'
827	46,8	'm'
828	46,9	9,4
829	49,5	41,7
830	50,5	37,8
831	52,3	20,4
832	54,1	30,7
833	56,3	41,8
834	58,7	26,5
835	57,3	'm'
836	59	'm'
837	59,8	'm'
838	60,3	'm'
839	61,2	'm'
840	61,8	'm'
841	62,5	'm'
842	62,4	'm'
843	61,5	'm'
844	63,7	'm'
845	61,9	'm'
846	61,6	29,7
847	60,3	'm'
848	59,2	'm'
849	57,3	'm'
850	52,3	'm'
851	49,3	'm'
852	47,3	'm'
853	46,3	38,8
854	46,8	35,1
855	46,6	'm'
'm'	= motoring.	

Status: This is the original version (as it was originally adopted).

856	44,3	'm'
857	43,1	'm'
858	42,4	2,1
859	41,8	2,4
860	43,8	68,8
861	44,6	89,2
862	46	99,2
863	46,9	99,4
864	47,9	99,7
865	50,2	99,8
866	51,2	99,6
867	52,3	99,4
868	53	99,3
869	54,2	99,2
870	55,5	99,1
871	56,7	99
872	57,3	98,9
873	58	98,9
874	60,5	31,1
875	60,2	'm'
876	60,3	'm'
877	60,5	6,3
878	61,4	19,3
879	60,3	1,2
880	60,5	2,9
881	61,2	34,1
882	61,6	13,2
883	61,5	16,4
884	61,2	16,4
885	61,3	'm'
886	63,1	'm'
887	63,2	4,8
888	62,3	22,3
'm'	= motoring.	

Status: This is the original version (as it was originally adopted).

889	62	38,5
890	61,6	29,6
891	61,6	26,6
892	61,8	28,1
893	62	29,6
894	62	16,3
895	61,1	'm'
896	61,2	'm'
897	60,7	19,2
898	60,7	32,5
899	60,9	17,8
900	60,1	19,2
901	59,3	38,2
902	59,9	45
903	59,4	32,4
904	59,2	23,5
905	59,5	40,8
906	58,3	'm'
907	58,2	'm'
908	57,6	'm'
909	57,1	'm'
910	57	0,6
911	57	26,3
912	56,5	29,2
913	56,3	20,5
914	56,1	'm'
915	55,2	'm'
916	54,7	17,5
917	55,2	29,2
918	55,2	29,2
919	55,9	16
920	55,9	26,3
921	56,1	36,5
'm'	= motoring.	

Status: This is the original version (as it was originally adopted).

922	55,8	19
923	55,9	9,2
924	55,8	21,9
925	56,4	42,8
926	56,4	38
927	56,4	11
928	56,4	35,1
929	54	7,3
930	53,4	5,4
931	52,3	27,6
932	52,1	32
933	52,3	33,4
934	52,2	34,9
935	52,8	60,1
936	53,7	69,7
937	54	70,7
938	55,1	71,7
939	55,2	46
940	54,7	12,6
941	52,5	0
942	51,8	24,7
943	51,4	43,9
944	50,9	71,1
945	51,2	76,8
946	50,3	87,5
947	50,2	99,8
948	50,9	100
949	49,9	99,7
950	50,9	100
951	49,8	99,7
952	50,4	99,8
953	50,4	99,8
954	49,7	99,7
'm'	= motoring.	

Status: This is the original version (as it was originally adopted).

955	51	100
956	50,3	99,8
957	50,2	99,8
958	49,9	99,7
959	50,9	100
960	50	99,7
961	50,2	99,8
962	50,2	99,8
963	49,9	99,7
964	50,4	99,8
965	50,2	99,8
966	50,3	99,8
967	49,9	99,7
968	51,1	100
969	50,6	99,9
970	49,9	99,7
971	49,6	99,6
972	49,4	99,6
973	49	99,5
974	49,8	99,7
975	50,9	100
976	50,4	99,8
977	49,8	99,7
978	49,1	99,5
979	50,4	99,8
980	49,8	99,7
981	49,3	99,5
982	49,1	99,5
983	49,9	99,7
984	49,1	99,5
985	50,4	99,8
986	50,9	100
987	51,4	99,9
'm'	= motoring.	

Status: This is the original version (as it was originally adopted).

988	51,5	99,9
989	52,2	99,7
990	52,8	74,1
991	53,3	46
992	53,6	36,4
993	53,4	33,5
994	53,9	58,9
995	55,2	73,8
996	55,8	52,4
997	55,7	9,2
998	55,8	2,2
999	56,4	33,6
1000	55,4	'm'
1001	55,2	'm'
1002	55,8	26,3
1003	55,8	23,3
1004	56,4	50,2
1005	57,6	68,3
1006	58,8	90,2
1007	59,9	98,9
1008	62,3	98,8
1009	63,1	74,4
1010	63,7	49,4
1011	63,3	9,8
1012	48	0
1013	47,9	73,5
1014	49,9	99,7
1015	49,9	48,8
1016	49,6	2,3
1017	49,9	'm'
1018	49,3	'm'
1019	49,7	47,5
1020	49,1	'm'
'm'	= motoring.	

Status: This is the original version (as it was originally adopted).

1021	49,4	'm'
1022	48,3	'm'
1023	49,4	'm'
1024	48,5	'm'
1025	48,7	'm'
1026	48,7	'm'
1027	49,1	'm'
1028	49	'm'
1029	49,8	'm'
1030	48,7	'm'
1031	48,5	'm'
1032	49,3	31,3
1033	49,7	45,3
1034	48,3	44,5
1035	49,8	61
1036	49,4	64,3
1037	49,8	64,4
1038	50,5	65,6
1039	50,3	64,5
1040	51,2	82,9
1041	50,5	86
1042	50,6	89
1043	50,4	81,4
1044	49,9	49,9
1045	49,1	20,1
1046	47,9	24
1047	48,1	36,2
1048	47,5	34,5
1049	46,9	30,3
1050	47,7	53,5
1051	46,9	61,6
1052	46,5	73,6
1053	48	84,6
'm'	= motoring.	

Status: This is the original version (as it was originally adopted).

1054	47,2	87,7
1055	48,7	80
1056	48,7	50,4
1057	47,8	38,6
1058	48,8	63,1
1059	47,4	5
1060	47,3	47,4
1061	47,3	49,8
1062	46,9	23,9
1063	46,7	44,6
1064	46,8	65,2
1065	46,9	60,4
1066	46,7	61,5
1067	45,5	'm'
1068	45,5	'm'
1069	44,2	'm'
1070	43	'm'
1071	42,5	'm'
1072	41	'm'
1073	39,9	'm'
1074	39,9	38,2
1075	40,1	48,1
1076	39,9	48
1077	39,4	59,3
1078	43,8	19,8
1079	52,9	0
1080	52,8	88,9
1081	53,4	99,5
1082	54,7	99,3
1083	56,3	99,1
1084	57,5	99
1085	59	98,9
1086	59,8	98,9
'm'	= motoring.	

Status: This is the original version (as it was originally adopted).

1087	60,1	98,9
1088	61,8	48,3
1089	61,8	55,6
1090	61,7	59,8
1091	62	55,6
1092	62,3	29,6
1093	62	19,3
1094	61,3	7,9
1095	61,1	19,2
1096	61,2	43
1097	61,1	59,7
1098	61,1	98,8
1099	61,3	98,8
1100	61,3	26,6
1101	60,4	'm'
1102	58,8	'm'
1103	57,7	'm'
1104	56	'm'
1105	54,7	'm'
1106	53,3	'm'
1107	52,6	23,2
1108	53,4	84,2
1109	53,9	99,4
1110	54,9	99,3
1111	55,8	99,2
1112	57,1	99
1113	56,5	99,1
1114	58,9	98,9
1115	58,7	98,9
1116	59,8	98,9
1117	61	98,8
1118	60,7	19,2
1119	59,4	'm'
'm'	= motoring.	

Status: This is the original version (as it was originally adopted).

1120	57,9	'm'
1121	57,6	'm'
1122	56,3	'm'
1123	55	'm'
1124	53,7	'm'
1125	52,1	'm'
1126	51,1	'm'
1127	49,7	25,8
1128	49,1	46,1
1129	48,7	46,9
1130	48,2	46,7
1131	48	70
1132	48	70
1133	47,2	67,6
1134	47,3	67,6
1135	46,6	74,7
1136	47,4	13
1137	46,3	'm'
1138	45,4	'm'
1139	45,5	24,8
1140	44,8	73,8
1141	46,6	99
1142	46,3	98,9
1143	48,5	99,4
1144	49,9	99,7
1145	49,1	99,5
1146	49,1	99,5
1147	51	100
1148	51,5	99,9
1149	50,9	100
1150	51,6	99,9
1151	52,1	99,7
1152	50,9	100
'm'	= motoring.	

Status: This is the original version (as it was originally adopted).

1153	52,2	99,7
1154	51,5	98,3
1155	51,5	47,2
1156	50,8	78,4
1157	50,3	83
1158	50,3	31,7
1159	49,3	31,3
1160	48,8	21,5
1161	47,8	59,4
1162	48,1	77,1
1163	48,4	87,6
1164	49,6	87,5
1165	51	81,4
1166	51,6	66,7
1167	53,3	63,2
1168	55,2	62
1169	55,7	43,9
1170	56,4	30,7
1171	56,8	23,4
1172	57	'm'
1173	57,6	'm'
1174	56,9	'm'
1175	56,4	4
1176	57	23,4
1177	56,4	41,7
1178	57	49,2
1179	57,7	56,6
1180	58,6	56,6
1181	58,9	64
1182	59,4	68,2
1183	58,8	71,4
1184	60,1	71,3
1185	60,6	79,1
'm'	= motoring.	

Status: This is the original version (as it was originally adopted).

1186	60,7	83,3
1187	60,7	77,1
1188	60	73,5
1189	60,2	55,5
1190	59,7	54,4
1191	59,8	73,3
1192	59,8	77,9
1193	59,8	73,9
1194	60	76,5
1195	59,5	82,3
1196	59,9	82,8
1197	59,8	65,8
1198	59	48,6
1199	58,9	62,2
1200	59,1	70,4
1201	58,9	62,1
1202	58,4	67,4
1203	58,7	58,9
1204	58,3	57,7
1205	57,5	57,8
1206	57,2	57,6
1207	57,1	42,6
1208	57	70,1
1209	56,4	59,6
1210	56,7	39
1211	55,9	68,1
1212	56,3	79,1
1213	56,7	89,7
1214	56	89,4
1215	56	93,1
1216	56,4	93,1
1217	56,7	94,4
1218	56,9	94,8
'm'	= motoring.	

Status: This is the original version (as it was originally adopted).

1219	57	94,1
1220	57,7	94,3
1221	57,5	93,7
1222	58,4	93,2
1223	58,7	93,2
1224	58,2	93,7
1225	58,5	93,1
1226	58,8	86,2
1227	59	72,9
1228	58,2	59,9
1229	57,6	8,5
1230	57,1	47,6
1231	57,2	74,4
1232	57	79,1
1233	56,7	67,2
1234	56,8	69,1
1235	56,9	71,3
1236	57	77,3
1237	57,4	78,2
1238	57,3	70,6
1239	57,7	64
1240	57,5	55,6
1241	58,6	49,6
1242	58,2	41,1
1243	58,8	40,6
1244	58,3	21,1
1245	58,7	24,9
1246	59,1	24,8
1247	58,6	'm'
1248	58,8	'm'
1249	58,8	'm'
1250	58,7	'm'
1251	59,1	'm'
'm'	= motoring.	

Status: This is the original version (as it was originally adopted).

1252	59,1	'm'
1253	59,4	'm'
1254	60,6	2,6
1255	59,6	'm'
1256	60,1	'm'
1257	60,6	'm'
1258	59,6	4,1
1259	60,7	7,1
1260	60,5	'm'
1261	59,7	'm'
1262	59,6	'm'
1263	59,8	'm'
1264	59,6	4,9
1265	60,1	5,9
1266	59,9	6,1
1267	59,7	'm'
1268	59,6	'm'
1269	59,7	22
1270	59,8	10,3
1271	59,9	10
1272	60,6	6,2
1273	60,5	7,3
1274	60,2	14,8
1275	60,6	8,2
1276	60,6	5,5
1277	61	14,3
1278	61	12
1279	61,3	34,2
1280	61,2	17,1
1281	61,5	15,7
1282	61	9,5
1283	61,1	9,2
1284	60,5	4,3
'm'	= motoring.	

Status: This is the original version (as it was originally adopted).

1285	60,2	7,8
1286	60,2	5,9
1287	60,2	5,3
1288	59,9	4,6
1289	59,4	21,5
1290	59,6	15,8
1291	59,3	10,1
1292	58,9	9,4
1293	58,8	9
1294	58,9	35,4
1295	58,9	30,7
1296	58,9	25,9
1297	58,7	22,9
1298	58,7	24,4
1299	59,3	61
1300	60,1	56
1301	60,5	50,6
1302	59,5	16,2
1303	59,7	50
1304	59,7	31,4
1305	60,1	43,1
1306	60,8	38,4
1307	60,9	40,2
1308	61,3	49,7
1309	61,8	45,9
1310	62	45,9
1311	62,2	45,8
1312	62,6	46,8
1313	62,7	44,3
1314	62,9	44,4
1315	63,1	43,7
1316	63,5	46,1
1317	63,6	40,7
'm'	= motoring.	

Status: This is the original version (as it was originally adopted).

1318	64,3	49,5
1319	63,7	27
1320	63,8	15
1321	63,6	18,7
1322	63,4	8,4
1323	63,2	8,7
1324	63,3	21,6
1325	62,9	19,7
1326	63	22,1
1327	63,1	20,3
1328	61,8	19,1
1329	61,6	17,1
1330	61	0
1331	61,2	22
1332	60,8	40,3
1333	61,1	34,3
1334	60,7	16,1
1335	60,6	16,6
1336	60,5	18,5
1337	60,6	29,8
1338	60,9	19,5
1339	60,9	22,3
1340	61,4	35,8
1341	61,3	42,9
1342	61,5	31
1343	61,3	19,2
1344	61	9,3
1345	60,8	44,2
1346	60,9	55,3
1347	61,2	56
1348	60,9	60,1
1349	60,7	59,1
1350	60,9	56,8
'm'	= motoring.	

Status: This is the original version (as it was originally adopted).

1351	60,7	58,1
1352	59,6	78,4
1353	59,6	84,6
1354	59,4	66,6
1355	59,3	75,5
1356	58,9	49,6
1357	59,1	75,8
1358	59	77,6
1359	59	67,8
1360	59	56,7
1361	58,8	54,2
1362	58,9	59,6
1363	58,9	60,8
1364	59,3	56,1
1365	58,9	48,5
1366	59,3	42,9
1367	59,4	41,4
1368	59,6	38,9
1369	59,4	32,9
1370	59,3	30,6
1371	59,4	30
1372	59,4	25,3
1373	58,8	18,6
1374	59,1	18
1375	58,5	10,6
1376	58,8	10,5
1377	58,5	8,2
1378	58,7	13,7
1379	59,1	7,8
1380	59,1	6
1381	59,1	6
1382	59,4	13,1
1383	59,7	22,3

'm' = motoring.

Status: This is the original version (as it was originally adopted).

1384	60,7	10,5
1385	59,8	9,8
1386	60,2	8,8
1387	59,9	8,7
1388	61	9,1
1389	60,6	28,2
1390	60,6	22
1391	59,6	23,2
1392	59,6	19
1393	60,6	38,4
1394	59,8	41,6
1395	60	47,3
1396	60,5	55,4
1397	60,9	58,7
1398	61,3	37,9
1399	61,2	38,3
1400	61,4	58,7
1401	61,3	51,3
1402	61,4	71,1
1403	61,1	51
1404	61,5	56,6
1405	61	60,6
1406	61,1	75,4
1407	61,4	69,4
1408	61,6	69,9
1409	61,7	59,6
1410	61,8	54,8
1411	61,6	53,6
1412	61,3	53,5
1413	61,3	52,9
1414	61,2	54,1
1415	61,3	53,2
1416	61,2	52,2
'm'	= motoring.	

Status: This is the original version (as it was originally adopted).

1417	61,2	52,3
1418	61	48
1419	60,9	41,5
1420	61	32,2
1421	60,7	22
1422	60,7	23,3
1423	60,8	38,8
1424	61	40,7
1425	61	30,6
1426	61,3	62,6
1427	61,7	55,9
1428	62,3	43,4
1429	62,3	37,4
1430	62,3	35,7
1431	62,8	34,4
1432	62,8	31,5
1433	62,9	31,7
1434	62,9	29,9
1435	62,8	29,4
1436	62,7	28,7
1437	61,5	14,7
1438	61,9	17,2
1439	61,5	6,1
1440	61	9,9
1441	60,9	4,8
1442	60,6	11,1
1443	60,3	6,9
1444	60,8	7
1445	60,2	9,2
1446	60,5	21,7
1447	60,2	22,4
1448	60,7	31,6
1449	60,9	28,9

'm'

= motoring.

Status: This is the original version (as it was originally adopted).

1450	59,6	21,7
1451	60,2	18
1452	59,5	16,7
1453	59,8	15,7
1454	59,6	15,7
1455	59,3	15,7
1456	59	7,5
1457	58,8	7,1
1458	58,7	16,5
1459	59,2	50,7
1460	59,7	60,2
1461	60,4	44
1462	60,2	35,3
1463	60,4	17,1
1464	59,9	13,5
1465	59,9	12,8
1466	59,6	14,8
1467	59,4	15,9
1468	59,4	22
1469	60,4	38,4
1470	59,5	38,8
1471	59,3	31,9
1472	60,9	40,8
1473	60,7	39
1474	60,9	30,1
1475	61	29,3
1476	60,6	28,4
1477	60,9	36,3
1478	60,8	30,5
1479	60,7	26,7
1480	60,1	4,7
1481	59,9	0
1482	60,4	36,2

'm' = motoring.

Status: This is the original version (as it was originally adopted).

1483	60,7	32,5
1484	59,9	3,1
1485	59,7	'm'
1486	59,5	'm'
1487	59,2	'm'
1488	58,8	0,6
1489	58,7	'm'
1490	58,7	'm'
1491	57,9	'm'
1492	58,2	'm'
1493	57,6	'm'
1494	58,3	9,5
1495	57,2	6
1496	57,4	27,3
1497	58,3	59,9
1498	58,3	7,3
1499	58,8	21,7
1500	58,8	38,9
1501	59,4	26,2
1502	59,1	25,5
1503	59,1	26
1504	59	39,1
1505	59,5	52,3
1506	59,4	31
1507	59,4	27
1508	59,4	29,8
1509	59,4	23,1
1510	58,9	16
1511	59	31,5
1512	58,8	25,9
1513	58,9	40,2
1514	58,8	28,4
1515	58,9	38,9
'm'	= motoring.	

Status: This is the original version (as it was originally adopted).

1516	59,1	35,3
1517	58,8	30,3
1518	59	19
1519	58,7	3
1520	57,9	0
1521	58	2,4
1522	57,1	'm'
1523	56,7	'm'
1524	56,7	5,3
1525	56,6	2,1
1526	56,8	'm'
1527	56,3	'm'
1528	56,3	'm'
1529	56	'm'
1530	56,7	'm'
1531	56,6	3,8
1532	56,9	'm'
1533	56,9	'm'
1534	57,4	'm'
1535	57,4	'm'
1536	58,3	13,9
1537	58,5	'm'
1538	59,1	'm'
1539	59,4	'm'
1540	59,6	'm'
1541	59,5	'm'
1542	59,6	0,5
1543	59,3	9,2
1544	59,4	11,2
1545	59,1	26,8
1546	59	11,7
1547	58,8	6,4
1548	58,7	5
'm'	= motoring.	

Status: This is the original version (as it was originally adopted).

1549	57,5	'm'
1550	57,4	'm'
1551	57,1	1,1
1552	57,1	0
1553	57	4,5
1554	57,1	3,7
1555	57,3	3,3
1556	57,3	16,8
1557	58,2	29,3
1558	58,7	12,5
1559	58,3	12,2
1560	58,6	12,7
1561	59	13,6
1562	59,8	21,9
1563	59,3	20,9
1564	59,7	19,2
1565	60,1	15,9
1566	60,7	16,7
1567	60,7	18,1
1568	60,7	40,6
1569	60,7	59,7
1570	61,1	66,8
1571	61,1	58,8
1572	60,8	64,7
1573	60,1	63,6
1574	60,7	83,2
1575	60,4	82,2
1576	60	80,5
1577	59,9	78,7
1578	60,8	67,9
1579	60,4	57,7
1580	60,2	60,6
1581	59,6	72,7
'm'	= motoring.	

Status: This is the original version (as it was originally adopted).

1582	59,9	73,6
1583	59,8	74,1
1584	59,6	84,6
1585	59,4	76,1
1586	60,1	76,9
1587	59,5	84,6
1588	59,8	77,5
1589	60,6	67,9
1590	59,3	47,3
1591	59,3	43,1
1592	59,4	38,3
1593	58,7	38,2
1594	58,8	39,2
1595	59,1	67,9
1596	59,7	60,5
1597	59,5	32,9
1598	59,6	20
1599	59,6	34,4
1600	59,4	23,9
1601	59,6	15,7
1602	59,9	41
1603	60,5	26,3
1604	59,6	14
1605	59,7	21,2
1606	60,9	19,6
1607	60,1	34,3
1608	59,9	27
1609	60,8	25,6
1610	60,6	26,3
1611	60,9	26,1
1612	61,1	38
1613	61,2	31,6
1614	61,4	30,6
'm'	= motoring.	

Status: This is the original version (as it was originally adopted).

1615	61,7	29,6
1616	61,5	28,8
1617	61,7	27,8
1618	62,2	20,3
1619	61,4	19,6
1620	61,8	19,7
1621	61,8	18,7
1622	61,6	17,7
1623	61,7	8,7
1624	61,7	1,4
1625	61,7	5,9
1626	61,2	8,1
1627	61,9	45,8
1628	61,4	31,5
1629	61,7	22,3
1630	62,4	21,7
1631	62,8	21,9
1632	62,2	22,2
1633	62,5	31
1634	62,3	31,3
1635	62,6	31,7
1636	62,3	22,8
1637	62,7	12,6
1638	62,2	15,2
1639	61,9	32,6
1640	62,5	23,1
1641	61,7	19,4
1642	61,7	10,8
1643	61,6	10,2
1644	61,4	'm'
1645	60,8	'm'
1646	60,7	'm'
1647	61	12,4
'm'	= motoring.	

Status: This is the original version (as it was originally adopted).

1648	60,4	5,3
1649	61	13,1
1650	60,7	29,6
1651	60,5	28,9
1652	60,8	27,1
1653	61,2	27,3
1654	60,9	20,6
1655	61,1	13,9
1656	60,7	13,4
1657	61,3	26,1
1658	60,9	23,7
1659	61,4	32,1
1660	61,7	33,5
1661	61,8	34,1
1662	61,7	17
1663	61,7	2,5
1664	61,5	5,9
1665	61,3	14,9
1666	61,5	17,2
1667	61,1	'm'
1668	61,4	'm'
1669	61,4	8,8
1670	61,3	8,8
1671	61	18
1672	61,5	13
1673	61	3,7
1674	60,9	3,1
1675	60,9	4,7
1676	60,6	4,1
1677	60,6	6,7
1678	60,6	12,8
1679	60,7	11,9
1680	60,6	12,4
'm'	= motoring.	

Status: This is the original version (as it was originally adopted).

1681	60,1	12,4
1682	60,5	12
1683	60,4	11,8
1684	59,9	12,4
1685	59,6	12,4
1686	59,6	9,1
1687	59,9	0
1688	59,9	20,4
1689	59,8	4,4
1690	59,4	3,1
1691	59,5	26,3
1692	59,6	20,1
1693	59,4	35
1694	60,9	22,1
1695	60,5	12,2
1696	60,1	11
1697	60,1	8,2
1698	60,5	6,7
1699	60	5,1
1700	60	5,1
1701	60	9
1702	60,1	5,7
1703	59,9	8,5
1704	59,4	6
1705	59,5	5,5
1706	59,5	14,2
1707	59,5	6,2
1708	59,4	10,3
1709	59,6	13,8
1710	59,5	13,9
1711	60,1	18,9
1712	59,4	13,1
1713	59,8	5,4
'm'	= motoring.	

Status: This is the original version (as it was originally adopted).

1714	59,9	2,9
1715	60,1	7,1
1716	59,6	12
1717	59,6	4,9
1718	59,4	22,7
1719	59,6	22
1720	60,1	17,4
1721	60,2	16,6
1722	59,4	28,6
1723	60,3	22,4
1724	59,9	20
1725	60,2	18,6
1726	60,3	11,9
1727	60,4	11,6
1728	60,6	10,6
1729	60,8	16
1730	60,9	17
1731	60,9	16,1
1732	60,7	11,4
1733	60,9	11,3
1734	61,1	11,2
1735	61,1	25,6
1736	61	14,6
1737	61	10,4
1738	60,6	'm'
1739	60,9	'm'
1740	60,8	4,8
1741	59,9	'm'
1742	59,8	'm'
1743	59,1	'm'
1744	58,8	'm'
1745	58,8	'm'
1746	58,2	'm'
'm'	= motoring.	

Status: This is the original version (as it was originally adopted).

1747	58,5	14,3
1748	57,5	4,4
1749	57,9	0
1750	57,8	20,9
1751	58,3	9,2
1752	57,8	8,2
1753	57,5	15,3
1754	58,4	38
1755	58,1	15,4
1756	58,8	11,8
1757	58,3	8,1
1758	58,3	5,5
1759	59	4,1
1760	58,2	4,9
1761	57,9	10,1
1762	58,5	7,5
1763	57,4	7
1764	58,2	6,7
1765	58,2	6,6
1766	57,3	17,3
1767	58	11,4
1768	57,5	47,4
1769	57,4	28,8
1770	58,8	24,3
1771	57,7	25,5
1772	58,4	35,5
1773	58,4	29,3
1774	59	33,8
1775	59	18,7
1776	58,8	9,8
1777	58,8	23,9
1778	59,1	48,2
1779	59,4	37,2

'm' = motoring.

Status: This is the original version (as it was originally adopted).

1780	59,6	29,1
1781	50	25
1782	40	20
1783	30	15
1784	20	10
1785	10	5
1786	0	0
1787	0	0
1788	0	0
1789	0	0
1790	0	0
1791	0	0
1792	0	0
1793	0	0
1794	0	0
1795	0	0
1796	0	0
1797	0	0
1798	0	0
1799	0	0
1800	0	0
'm'	= motoring.	

A graphical display of the ETC dynamometer schedule is shown in Figure 5.

3.2.8.1.1.	Fuel composition:						
	methane (CH ₄):	basis:	%mole	min.	%mole	max.	%mole
	ethane (C ₂ H ₆):	basis:	%mole	min.	%mole	max.	%mole
	propane (C ₃ H ₈):	basis:	%mole	min.	%mole	max.	%mole
	butane (C ₄ H ₁₀):	basis:	%mole	min.	%mole	max.	%mole
	C5/C5+:	basis:	%mole	min.	%mole	max.	%mole
	oxygen (O ₂):	basis:	%mole	min.	%mole	max.	%mole
	inert (N ₂ , He etc.):	basis:	%mole	min.	%mole	max.	%mole

3.2.8.1.2. Injector(s)

3.2.8.1.2.1. Make(s):

3.2.8.1.2.2. Type(s):

3.2.8.1.3. Others (if applicable)

3.2.8.2. Variant 2
(only in the case of approvals for several specific fuel compositions)4. **Valve timing**4.1. Maximum lift of valves and angles of opening and closing in relation to dead centres or equivalent data:
.....4.2. Reference and/or setting ranges ⁽¹⁾:5. **Ignition system (spark ignition engines only)**5.1. Ignition system type: common coil and plugs/individual coil and plugs/coil on plug/other (specify) ⁽¹⁾

5.2. Ignition control unit

5.2.1. Make(s):

5.2.2. Type(s):

5.3. Ignition advance curve / advance map) ⁽¹⁾ ⁽²⁾:5.4. Ignition timing ⁽²⁾: degrees before TDC at a speed of rpm and a MAP of Pa

5.5. Spark plugs

5.5.1. Make(s):

5.5.2. Type(s):

5.5.3. Gap setting: mm

5.6. Ignition coil(s)

5.6.1. Make(s):

5.6.2. Type(s):

Appendix 4

MEASUREMENT AND SAMPLING PROCEDURES

1. INTRODUCTION

Gaseous components, particulates, and smoke emitted by the engine submitted for testing shall be measured by the methods described in Annex V. The respective sections of Annex V describe the recommended analytical systems for the gaseous emissions (Section 1), the recommended particulate dilution and sampling systems (Section 2), and the recommended opacimeters for smoke measurement (Section 3).

For the ESC, the gaseous components shall be determined in the raw exhaust gas. Optionally, they may be determined in the diluted exhaust gas, if a full flow dilution system is used for particulate determination. Particulates shall be determined with either a partial flow or a full flow dilution system.

For the ETC, only a full flow dilution system shall be used for determining gaseous and particulate emissions, and is considered the reference system. However, partial flow dilution systems may be approved by the Technical Service, if their equivalency according to Section 6.2 to Annex I is proven, and if a detailed description of the data evaluation and calculation procedures is submitted to the Technical Service.

2. DYNAMOMETER AND TEST CELL EQUIPMENT

The following equipment shall be used for emission tests of engines on engine dynamometers.

2.1. Engine dynamometer

An engine dynamometer shall be used with adequate characteristics to perform the test cycles described in Appendices 1 and 2 to this Annex. The speed measuring system shall have an accuracy of $\pm 2\%$ of reading. The torque measuring system shall have an accuracy of $\pm 3\%$ of reading in the range $> 20\%$ of full scale, and an accuracy of $\pm 0,6\%$ of full scale in the range $\leq 20\%$ of full scale.

2.2. Other instruments

Measuring instruments for fuel consumption, air consumption, temperature of coolant and lubricant, exhaust gas pressure and intake manifold depression, exhaust gas temperature, air intake temperature, atmospheric pressure, humidity and fuel temperature shall be used, as required. These instruments shall satisfy the requirements given in Table 8:

Table 8

Accuracy of measuring instruments	
Measuring instrument	Accuracy
Fuel consumption	$\pm 2\%$ of engine's maximum value
Air consumption	$\pm 2\%$ of engine's maximum value
Temperatures ≤ 600 K (327 °C)	± 2 K absolute
Temperatures >600 K (327 °C)	$\pm 1\%$ of reading
Atmospheric pressure	$\pm 0,1$ kPa absolute

Table 8

Accuracy of measuring instruments	
Exhaust gas pressure	± 0,2 kPa absolute
Intake depression	± 0,05 kPa absolute
Other pressures	± 0,1 kPa absolute
Relative humidity	± 3 % absolute
Absolute humidity	± 5 % of reading

2.3. Exhaust gas flow

For calculation of the emissions in the raw exhaust, it is necessary to know the exhaust gas flow (see Section 4.4 of Appendix 1). For the determination of the exhaust flow either of the following methods may be used:

- a) direct measurement of the exhaust flow by flow nozzle or equivalent metering system;
- b) measurement of the air flow and the fuel flow by suitable metering systems and calculation of the exhaust flow by the following equation:

$$G_{\text{EXHW}} = G_{\text{AIRW}} + G_{\text{FUEL}} \text{ (for wet exhaust mass)}$$

The accuracy of exhaust flow determination shall be ± 2,5 % of reading or better.

2.4. Diluted exhaust gas flow

For calculation of the emissions in the diluted exhaust using a full flow dilution system (mandatory for the ETC), it is necessary to know the diluted exhaust gas flow (see Section 4.3 of Appendix 2). The total mass flow rate of the diluted exhaust (G_{TOTW}) or the total mass of the diluted exhaust gas over the cycle (M_{TOTW}) shall be measured with a PDP or CFV (Annex V, Section 2.3.1). The accuracy shall be ± 2 % of reading or better, and shall be determined according to the provisions of Annex III, Appendix 5, Section 2.4.

3. DETERMINATION OF THE GASEOUS COMPONENTS

3.1. General analyser specifications

The analysers shall have a measuring range appropriate for the accuracy required to measure the concentrations of the exhaust gas components (Section 3.1.1). It is recommended that the analysers be operated such that the measured concentration falls between 15 % and 100 % of full scale.

If read-out systems (computers, data loggers) can provide sufficient accuracy and resolution below 15 % of full scale, measurements below 15 % of full scale are also acceptable. In this case, additional calibrations of at least four non-zero nominally equally spaced points are to be made to ensure the accuracy of the calibration curves according to Annex III, Appendix 5, Section 1.5.5.2.

The electromagnetic compatibility (EMC) of the equipment shall be on a level as to minimise additional errors.

3.1.1. Measurement error

The total measurement error, including the cross sensitivity to other gases (see Annex III, Appendix 5, Section 1.9), shall not exceed $\pm 5\%$ of the reading or $\pm 3,5\%$ of full scale, whichever is smaller. For concentrations of less than 100 ppm the measurement error shall not exceed ± 4 ppm.

3.1.2. Repeatability

The repeatability, defined as 2,5 times the standard deviation of 10 repetitive responses to a given calibration or span gas, has to be not greater than $\pm 1\%$ of full scale concentration for each range used above 155 ppm (or ppmC) or $\pm 2\%$ of each range used below 155 ppm (or ppmC).

3.1.3. Noise

The analyser peak-to-peak response to zero and calibration or span gases over any 10 second period shall not exceed 2% of full scale on all ranges used.

3.1.4. Zero drift

The zero drift during a one hour period shall be less than 2% of full scale on the lowest range used. The zero response is defined as the mean response, including noise, to a zero gas during a 30 seconds time interval.

3.1.5. Span drift

The span drift during a one hour period shall be less than 2% of full scale on the lowest range used. Span is defined as the difference between the span response and the zero response. The span response is defined as the mean response, including noise, to a span gas during a 30 seconds time interval.

3.2. Gas drying

The optional gas drying device must have a minimal effect on the concentration of the measured gases. Chemical dryers are not an acceptable method of removing water from the sample.

3.3. Analysers

Sections 3.3.1 to 3.3.4 describe the measurement principles to be used. A detailed description of the measurement systems is given in Annex V. The gases to be measured shall be analysed with the following instruments. For non-linear analysers, the use of linearising circuits is permitted.

3.3.1. Carbon monoxide (CO) analysis

The carbon monoxide analyser shall be of the Non-Dispersive InfraRed (NDIR) absorption type.

3.3.2. Carbon dioxide (CO₂) analysis

The carbon dioxide analyser shall be of the Non-Dispersive InfraRed (NDIR) absorption type.

3.3.3. Hydrocarbon (HC) analysis

For diesel and LPG fuelled gas engines, the hydrocarbon analyser shall be of the Heated Flame Ionisation Detector (HFID) type with detector, valves, pipework, etc. heated so as to maintain a gas temperature of $463\text{K} \pm 10\text{K}$ ($190 \pm 10\text{ }^\circ\text{C}$). For NG fuelled gas engines, the hydrocarbon analyser may be of the non-heated Flame Ionisation Detector (FID) type depending upon the method used (see Annex V, Section 1.3).

3.3.4. Non-methane hydrocarbon (NMHC) analysis (NG fuelled gas engines only)

Non-methane hydrocarbons shall be determined by either of the following methods:

3.3.4.1. Gas chromatographic (GC) method

Non-methane hydrocarbons shall be determined by subtraction of the methane analysed with a Gas Chromatograph (GC) conditioned at 423 K (150 °C) from the hydrocarbons measured according to Section 3.3.3.

3.3.4.2. Non-methane cutter (NMC) method

The determination of the non-methane fraction shall be performed with a heated NMC operated in line with an FID as per Section 3.3.3 by subtraction of the methane from the hydrocarbons.

3.3.5. Oxides of nitrogen (NO_x) analysis

The oxides of nitrogen analyser shall be of the ChemiLuminescent Detector (CLD) or Heated ChemiLuminescent Detector (HCLD) type with a NO₂/NO converter, if measured on a dry basis. If measured on a wet basis, a HCLD with converter maintained above 328 K (55 °C) shall be used, provided the water quench check (see Annex III, Appendix 5, Section 1.9.2.2) is satisfied.

3.4. Sampling of gaseous emissions

3.4.1. Raw exhaust gas (ESC only)

The gaseous emissions sampling probes must be fitted at least 0,5 m or 3 times the diameter of the exhaust pipe whichever is the larger-upstream of the exit of the exhaust gas system as far as applicable and sufficiently close to the engine as to ensure an exhaust gas temperature of at least 343 K (70 °C) at the probe.

In the case of a multi-cylinder engine with a branched exhaust manifold, the inlet of the probe shall be located sufficiently far downstream so as to ensure that the sample is representative of the average exhaust emissions from all cylinders. In multi-cylinder engines having distinct groups of manifolds, such as in a 'Vee' engine configuration, it is permissible to acquire a sample from each group individually and calculate an average exhaust emission. Other methods which have been shown to correlate with the above methods may be used. For exhaust emission calculation the total exhaust mass flow must be used.

If the engine is equipped with an exhaust aftertreatment system, the exhaust sample shall be taken downstream of the exhaust aftertreatment system.

3.4.2. Diluted exhaust gas (mandatory for ETC, optional for ESC)

The exhaust pipe between the engine and the full flow dilution system shall conform to the requirements of Annex V, Section 2.3.1, EP.

The gaseous emissions sample probe(s) shall be installed in the dilution tunnel at a point where the dilution air and exhaust gas are well mixed, and in close proximity to the particulates sampling probe.

For the ETC, sampling can generally be done in two ways:

- the pollutants are sampled into a sampling bag over the cycle and measured after completion of the test;
- the pollutants are sampled continuously and integrated over the cycle; this method is mandatory for HC and NO_x.

4. DETERMINATION OF THE PARTICULATES

The determination of the particulates requires a dilution system. Dilution may be accomplished by a partial flow dilution system (ESC only) or a full flow dilution system (mandatory for ETC).

The flow capacity of the dilution system shall be large enough to completely eliminate water condensation in the dilution and sampling systems, and maintain the temperature of the diluted exhaust gas at or below 325K (52 °C) immediately upstream of the filter holders. Dehumidifying the dilution air before entering the dilution system is permitted, and especially useful if dilution air humidity is high. The temperature of the dilution air shall be $298\text{ K} \pm 5\text{ K}$ ($25\text{ °C} \pm 5\text{ °C}$). If the ambient temperature is below 293 K (20 °C), dilution air pre-heating above the upper temperature limit of 303K (30 °C) is recommended. However, the dilution air temperature must not exceed 325 K (52 °C) prior to the introduction of the exhaust in the dilution tunnel.

The partial flow dilution system has to be designed to split the exhaust stream into two fractions, the smaller one being diluted with air and subsequently used for particulate measurement. For this it is essential that the dilution ratio be determined very accurately. Different splitting methods can be applied, whereby the type of splitting used dictates to a significant degree the sampling hardware and procedures to be used (Annex V, Section 2.2). The particulate sampling probe shall be installed in close proximity to the gaseous emissions sampling probe, and the installation shall comply with the provisions of Section 3.4.1.

To determine the mass of the particulates, a particulate sampling system, particulate sampling filters, a microgram balance, and a temperature and humidity controlled weighing chamber, are required.

For particulate sampling, the single filter method shall be applied which uses one pair of filters (see Section 4.1.3) for the whole test cycle. For the ESC, considerable attention must be paid to sampling times and flows during the sampling phase of the test.

4.1. Particulate sampling filters

4.1.1. Filter specification

Fluorocarbon coated glass fibre filters or fluorocarbon based membrane filters are required. All filter types shall have a 0,3 µm DOP (di-octylphthalate) collection efficiency of at least 95 % at a gas face velocity between 35 and 80 cm/s.

4.1.2. Filter size

Particulate filters must have a minimum diameter of 47 mm (37 mm stain diameter). Larger diameter filters are acceptable (Section 4.1.5).

4.1.3. Primary and back-up filters

The diluted exhaust shall be sampled by a pair of filters placed in series (one primary and one back-up filter) during the test sequence. The back-up filter shall be located no more than 100 mm downstream of, and shall not be in contact with the primary filter. The filters may be weighed separately or as a pair with the filters placed stain side to stain side.

4.1.4. Filter face velocity

A gas face velocity through the filter of 35 to 80 cm/s shall be achieved. The pressure drop increase between the beginning and the end of the test shall be no more than 25 kPa.

4.1.5. Filter loading

The recommended minimum filter loading shall be 0,5 mg/1 075 mm² stain area. For the most common filter sizes the values are shown in Table 9.

Table 9

Recommended filter loadings

Filter diameter	Recommended stain	Recommended minimum loading
(mm)	(mm)	(mg)
47	37	0,5
70	60	1,3
90	80	2,3
110	100	3,6

4.2. Weighing chamber and analytical balance specifications

4.2.1. Weighing chamber conditions

The temperature of the chamber (or room) in which the particulate filters are conditioned and weighed shall be maintained to within $295\text{ K} \pm 3\text{ K}$ ($22\text{ °C} \pm 3\text{ °C}$) during all filter conditioning and weighing. The humidity shall be maintained to a dewpoint of $282,5\text{ K} \pm 3\text{ K}$ ($9,5\text{ °C} \pm 3\text{ °C}$) and a relative humidity of $45\% \pm 8\%$.

4.2.2. Reference filter weighing

The chamber (or room) environment shall be free of any ambient contaminants (such as dust) that would settle on the particulate filters during their stabilisation. Disturbances to weighing room specifications as outlined in Section 4.2.1 will be allowed if the duration of the disturbances does not exceed 30 minutes. The weighing room should meet the required specifications prior to personal entrance into the weighing room. At least two unused reference filters or reference filter pairs shall be weighed within 4 hours of, but preferably at the same time as the sample filter (pair) weighings. They shall be the same size and material as the sample filters.

If the average weight of the reference filters (reference filter pairs) changes between sample filter weighings by more than $\pm 5\%$ ($\pm 7,5\%$ for the filter pair respectively) of the recommended minimum filter loading (Section 4.1.5), then all sample filters shall be discarded and the emissions test repeated.

If the weighing room stability criteria outlined in Section 4.2.1 is not met, but the reference filter (pair) weighings meet the above criteria, the engine manufacturer has the option of accepting the sample filter weights or voiding the tests, fixing the weighing room control system and rerunning the test.

4.2.3. Analytical balance

The analytical balance used to determine the weights of all filters shall have a precision (standard deviation) of $20\text{ }\mu\text{g}$ and a resolution of $10\text{ }\mu\text{g}$ (1 digit = $10\text{ }\mu\text{g}$). For filters less than 70 mm diameter, the precision and resolution shall be $2\text{ }\mu\text{g}$ and $1\text{ }\mu\text{g}$, respectively.

4.3. Additional specifications for particulate measurement

All parts of the dilution system and the sampling system from the exhaust pipe up to the filter holder, which are in contact with raw and diluted exhaust gas, must be designed to minimise deposition or alteration of the particulates. All parts must be made of electrically conductive

materials that do not react with exhaust gas components, and must be electrically grounded to prevent electrostatic effects.

5. DETERMINATION OF SMOKE

This section provides specifications for the required and optional test equipment to be used for the ELR test. The smoke shall be measured with an opacimeter having an opacity and a light absorption coefficient readout mode. The opacity readout mode shall only be used for calibration and checking of the opacimeter. The smoke values of the test cycle shall be measured in the light absorption coefficient readout mode.

5.1. General requirements

The ELR requires the use of a smoke measurement and data processing system which includes three functional units. These units may be integrated into a single component or provided as a system of interconnected components. The three functional units are:

- an opacimeter meeting the specifications of Annex V, Section 3,
- a data processing unit capable of performing the functions described in Annex III, Appendix 1, Section 6,
- a printer and/or electronic storage medium to record and output the required smoke values specified in Annex III, Appendix 1, Section 6.3.

5.2. Specific requirements

5.2.1. Linearity

The linearity shall be within ± 2 % opacity.

5.2.2. Zero drift

The zero drift during a one hour period shall not exceed ± 1 % opacity.

5.2.3. Opacimeter display and range

For display in opacity, the range shall be 0-100 % opacity, and the readability 0,1 % opacity. For display in light absorption coefficient, the range shall be 0-30 m^{-1} light absorption coefficient, and the readability 0,01 m^{-1} light absorption coefficient.

5.2.4. Instrument response time

The physical response time of the opacimeter shall not exceed 0,2 s. The physical response time is the difference between the times when the output of a rapid response receiver reaches 10 and 90 % of the full deviation when the opacity of the gas being measured is changed in less than 0,1 s.

The electrical response time of the opacimeter shall not exceed 0,05 s. The electrical response time is the difference between the times when the opacimeter output reaches 10 and 90 % of the full scale when the light source is interrupted or completely extinguished in less than 0,01 s.

5.2.5. Neutral density filters

Any neutral density filter used in conjunction with opacimeter calibration, linearity measurements, or setting span shall have its value known to within 1,0 % opacity. The filter's nominal value must be checked for accuracy at least yearly using a reference traceable to a national or international standard.

Status: This is the original version (as it was originally adopted).

Neutral density filters are precision devices and can easily be damaged during use. Handling should be minimised and, when required, should be done with care to avoid scratching or soiling of the filter.

Appendix 5

CALIBRATION PROCEDURE

1. CALIBRATION OF THE ANALYTICAL INSTRUMENTS

1.1. Introduction

Each analyser shall be calibrated as often as necessary to fulfil the accuracy requirements of this Directive. The calibration method that shall be used is described in this section for the analysers indicated in Annex III, Appendix 4, Section 3 and Annex V, Section 1.

1.2. Calibration gases

The shelf life of all calibration gases must be respected.

The expiration date of the calibration gases stated by the manufacturer shall be recorded.

1.2.1. Pure gases

The required purity of the gases is defined by the contamination limits given below. The following gases must be available for operation:

Purified nitrogen

(Contamination ≤ 1 ppm C1, ≤ 1 ppm CO, ≤ 400 ppm CO₂, $\leq 0,1$ ppm NO)

Purified oxygen

(Purity $> 99,5$ % vol O₂)

Hydrogen-helium mixture

(40 ± 2 % hydrogen, balance helium)

(Contamination ≤ 1 ppm C1, ≤ 400 ppm CO₂)

Purified synthetic air

(Contamination ≤ 1 ppm C1, ≤ 1 ppm CO, ≤ 400 ppm CO₂, $\leq 0,1$ ppm NO)

(Oxygen content between 18-21 % vol.)

Purified propane or CO for the CVS verification

1.2.2. Calibration and span gases

Mixtures of gases having the following chemical compositions shall be available:

C₃H₈ and purified synthetic air (see Section 1.2.1);

CO and purified nitrogen;

NO_x and purified nitrogen (the amount of NO₂ contained in this calibration gas must not exceed 5 % of the NO content);

CO₂ and purified nitrogen;

CH₄ and purified synthetic air;

C₂H₆ and purified synthetic air.

Note: Other gas combinations are allowed provided the gases do not react with one another.

The true concentration of a calibration and span gas must be within $\pm 2\%$ of the nominal value. All concentrations of calibration gas shall be given on a volume basis (volume percent or volume ppm).

The gases used for calibration and span may also be obtained by means of a gas divider, diluting with purified N_2 or with purified synthetic air. The accuracy of the mixing device must be such that the concentration of the diluted calibration gases may be determined to within $\pm 2\%$.

1.3. Operating procedure for analysers and sampling system

The operating procedure for analysers shall follow the start-up and operating instructions of the instrument manufacturer. The minimum requirements given in Sections 1.4 to 1.9 shall be included.

1.4. Leakage test

A system leakage test shall be performed. The probe shall be disconnected from the exhaust system and the end plugged. The analyser pump shall be switched on. After an initial stabilisation period all flow meters should read zero. If not, the sampling lines shall be checked and the fault corrected.

The maximum allowable leakage rate on the vacuum side shall be 0,5 % of the in-use flow rate for the portion of the system being checked. The analyser flows and bypass flows may be used to estimate the in-use flow rates.

Another method is the introduction of a concentration step change at the beginning of the sampling line by switching from zero to span gas. If after an adequate period of time the reading shows a lower concentration compared to the introduced concentration, this points to calibration or leakage problems.

1.5. Calibration procedure

1.5.1. Instrument assembly

The instrument assembly shall be calibrated and calibration curves checked against standard gases. The same gas flow rates shall be used as when sampling exhaust.

1.5.2. Warming-up time

The warming-up time should be according to the recommendations of the manufacturer. If not specified, a minimum of two hours is recommended for warming up the analysers.

1.5.3. NDIR and HFID analyser

The NDIR analyser shall be tuned, as necessary, and the combustion flame of the HFID analyser shall be optimised (Section 1.8.1).

1.5.4. Calibration

Each normally used operating range shall be calibrated.

Using purified synthetic air (or nitrogen), the CO , CO_2 , NO_x and HC analysers shall be set at zero.

The appropriate calibration gases shall be introduced to the analysers, the values recorded, and the calibration curve established according to Section 1.5.5.

The zero setting shall be rechecked and the calibration procedure repeated, if necessary.

1.5.5. Establishment of the calibration curve

1.5.5.1. General guidelines

The analyser calibration curve shall be established by at least five calibration points (excluding zero) spaced as uniformly as possible. The highest nominal concentration must be equal to or higher than 90 % of full scale.

The calibration curve shall be calculated by the method of least squares. If the resulting polynomial degree is greater than 3, the number of calibration points (zero included) must be at least equal to this polynomial degree plus 2.

The calibration curve must not differ by more than ± 2 % from the nominal value of each calibration point and by more than ± 1 % of full scale at zero.

From the calibration curve and the calibration points, it is possible to verify that the calibration has been carried out correctly. The different characteristic parameters of the analyser must be indicated, particularly:

- the measuring range,
- the sensitivity,
- the date of carrying out the calibration.

1.5.5.2. Calibration below 15 % of full scale

The analyser calibration curve shall be established by at least 4 additional calibration points (excluding zero) spaced nominally equally below 15 % of full scale.

The calibration curve is calculated by the method of least squares.

The calibration curve must not differ by more than ± 4 % from the nominal value of each calibration point and by more than ± 1 % of full scale at zero.

1.5.5.3. Alternative methods

If it can be shown that alternative technology (e.g. computer, electronically controlled range switch, etc.) can give equivalent accuracy, then these alternatives may be used.

1.6. Verification of the calibration

Each normally used operating range shall be checked prior to each analysis in accordance with the following procedure.

The calibration shall be checked by using a zero gas and a span gas whose nominal value is more than 80 % of full scale of the measuring range.

If, for the two points considered, the value found does not differ by more than ± 4 % of full scale from the declared reference value, the adjustment parameters may be modified. Should this not be the case, a new calibration curve shall be established in accordance with Section 1.5.5.

1.7. Efficiency test of the NO_x converter

The efficiency of the converter used for the conversion of NO₂ into NO shall be tested as given in Sections 1.7.1 to 1.7.8 (Figure 6).

1.7.1. Test set-up

Using the test set-up as shown in Figure 6 (see also Annex III, Appendix 4, Section 3.3.5) and the procedure below, the efficiency of converters can be tested by means of an ozonator.

1.7.2. Calibration

The CLD and the HCLD shall be calibrated in the most common operating range following the manufacturer's specifications using zero and span gas (the NO content of which must amount to about 80 % of the operating range and the NO₂ concentration of the gas mixture to less than 5 % of the NO concentration). The NO_x analyser must be in the NO mode so that the span gas does not pass through the converter. The indicated concentration has to be recorded.

1.7.3. Calculation

The efficiency of the NO_x converter is calculated as follows:

$$\text{Efficiency (\%)} = \left(1 + \frac{a-b}{c-d}\right) \times 100$$

where,

- a = is the NO_x concentration according to Section 1.7.6
- b = is the NO_x concentration according to Section 1.7.7
- c = is the NO concentration according to Section 1.7.4
- d = is the NO concentration according to Section 1.7.5

1.7.4. Adding of oxygen

Via a T-fitting, oxygen or zero air is added continuously to the gas flow until the concentration indicated is about 20 % less than the indicated calibration concentration given in Section 1.7.2. (The analyser is in the NO mode). The indicated concentration c shall be recorded. The ozonator is kept deactivated throughout the process.

1.7.5. Activation of the ozonator

The ozonator is now activated to generate enough ozone to bring the NO concentration down to about 20 % (minimum 10 %) of the calibration concentration given in Section 1.7.2. The indicated concentration d shall be recorded. (The analyser is in the NO mode).

1.7.6. NO_x mode

The NO analyser is then switched to the NO_x mode so that the gas mixture (consisting of NO, NO₂, O₂ and N₂) now passes through the converter. The indicated concentration a shall be recorded. (The analyser is in the NO_x mode).

1.7.7. Deactivation of the ozonator

The ozonator is now deactivated. The mixture of gases described in Section 1.7.6 passes through the converter into the detector. The indicated concentration b shall be recorded. (The analyser is in the NO_x mode).

1.7.8. NO mode

Switched to NO mode with the ozonator deactivated, the flow of oxygen or synthetic air is also shut off. The NO_x reading of the analyser shall not deviate by more than ± 5 % from the value measured according to Section 1.7.2. (The analyser is in the NO mode).

1.7.9. Test interval

The efficiency of the converter must be tested prior to each calibration of the NO_x analyser.

1.7.10. Efficiency requirement

The efficiency of the converter shall not be less than 90 %, but a higher efficiency of 95 % is strongly recommended.

Note: If, with the analyser in the most common range, the ozonator cannot give a reduction from 80 % to 20 % according to Section 1.7.5, then the highest range which will give the reduction shall be used.

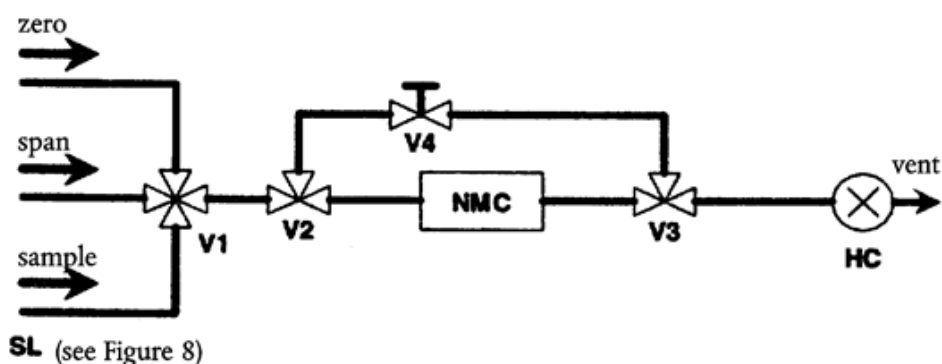

Bag sampling method

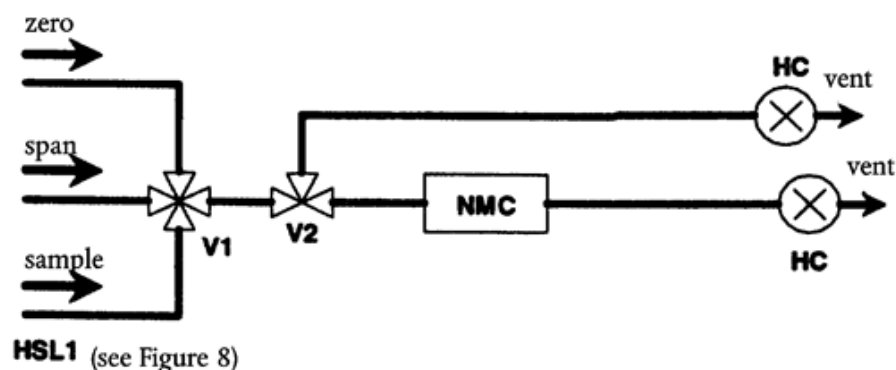

Integrating method

1.8. Adjustment of the FID

1.8.1. Optimisation of the detector response

The FID must be adjusted as specified by the instrument manufacturer. A propane in air span gas should be used to optimise the response on the most common operating range.

With the fuel and air flow rates set at the manufacturer's recommendations, a 350 ± 75 ppm C span gas shall be introduced to the analyser. The response at a given fuel flow shall be determined from the difference between the span gas response and the zero gas response. The fuel flow shall be incrementally adjusted above and below the manufacturer's specification. The span and zero response at these fuel flows shall be recorded. The difference between the span and zero response shall be plotted and the fuel flow adjusted to the rich side of the curve.

1.8.2. Hydrocarbon response factors

The analyser shall be calibrated using propane in air and purified synthetic air, according to Section 1.5.

Response factors shall be determined when introducing an analyser into service and after major service intervals. The response factor (R_f) for a particular hydrocarbon species is the ratio of the FID C1 reading to the gas concentration in the cylinder expressed by ppm C1.

The concentration of the test gas must be at a level to give a response of approximately 80 % of full scale. The concentration must be known to an accuracy of ± 2 % in reference to a gravimetric standard expressed in volume. In addition, the gas cylinder must be preconditioned for 24 hours at a temperature of $298 \text{ K} \pm 5 \text{ K}$ ($25 \text{ }^\circ\text{C} \pm 5 \text{ }^\circ\text{C}$).

The test gases to be used and the recommended relative response factor ranges are as follows:

methane and purified synthetic air $1,00 \leq R_f \leq 1,15$

propylene and purified synthetic air $0,90 \leq R_f \leq 1,10$

toluene and purified synthetic air $0,90 \leq R_f \leq 1,10$

These values are relative to the response factor (R_f) of 1,00 for propane and purified synthetic air.

1.8.3. Oxygen interference check

The oxygen interference check shall be determined when introducing an analyser into service and after major service intervals.

The response factor is defined and shall be determined as described in Section 1.8.2. The test gas to be used and the recommended relative response factor range are as follows:

propane and nitrogen $0,95 \leq R_f \leq 1,05$

This value is relative to the response factor (R_f) of 1,00 for propane and purified synthetic air.

The FID burner air oxygen concentration must be within ± 1 mole % of the oxygen concentration of the burner air used in the latest oxygen interference check. If the difference is greater, the oxygen interference must be checked and the analyser adjusted, if necessary.

1.8.4. Efficiency of the non-methane cutter (NMC, for NG fuelled gas engines only)

The NMC is used for the removal of the non-methane hydrocarbons from the sample gas by oxidising all hydrocarbons except methane. Ideally, the conversion for methane is 0 %, and for the other hydrocarbons represented by ethane is 100 %. For the accurate measurement of NMHC, the two efficiencies shall be determined and used for the calculation of the NMHC emission mass flow rate (see Annex III, Appendix 2, Section 4.3).

1.8.4.1. Methane efficiency

Methane calibration gas shall be flown through the FID with and without bypassing the NMC and the two concentrations recorded. The efficiency shall be determined as follows:

$$CE_M = 1 - \left(\frac{\text{conc}_w}{\text{conc}_{w/o}} \right)$$

where,

conc_w = HC concentration with CH_4 flowing through the NMC

$\text{conc}_{w/o}$ = HC concentration with CH_4 bypassing the NMC

1.8.4.2. Ethane efficiency

Ethane calibration gas shall be flown through the FID with and without bypassing the NMC and the two concentrations recorded. The efficiency shall be determined as follows

$$CE_E = 1 - \frac{conc_w}{conc_{w/o}}$$

where,

conc_w = HC concentration with C₂H₆ flowing through the NMC

conc_{w/o} = HC concentration with C₂H₆ bypassing the NMC

1.9. Interference effects with CO, CO₂, and NO_x analysers

Gases present in the exhaust other than the one being analysed can interfere with the reading in several ways. Positive interference occurs in NDIR instruments where the interfering gas gives the same effect as the gas being measured, but to a lesser degree. Negative interference occurs in NDIR instruments by the interfering gas broadening the absorption band of the measured gas, and in CLD instruments by the interfering gas quenching the radiation. The interference checks in Sections 1.9.1 and 1.9.2 shall be performed prior to an analyser's initial use and after major service intervals.

1.9.1. CO analyser interference check

Water and CO₂ can interfere with the CO analyser performance. Therefore, a CO₂ span gas having a concentration of 80 to 100 % of full scale of the maximum operating range used during testing shall be bubbled through water at room temperature and the analyser response recorded. The analyser response must not be more than 1 % of full scale for ranges equal to or above 300 ppm or more than 3 ppm for ranges below 300 ppm.

1.9.2. NO_x analyser quench checks

The two gases of concern for CLD (and HCLD) analysers are CO₂ and water vapour. Quench responses to these gases are proportional to their concentrations, and therefore require test techniques to determine the quench at the highest expected concentrations experienced during testing.

1.9.2.1. CO₂ quench check

A CO₂ span gas having a concentration of 80 to 100 % of full scale of the maximum operating range shall be passed through the NDIR analyser and the CO₂ value recorded as A. It shall then be diluted approximately 50 % with NO span gas and passed through the NDIR and (H)CLD, with the CO₂ and NO values recorded as B and C, respectively. The CO₂ shall then be shut off and only the NO span gas be passed through the (H)CLD and the NO value recorded as D.

The quench, which must not be greater than 3 % of full scale, shall be calculated as follows:

$$\% \text{ Quench} = \left[1 - \left(\frac{C \times A}{(D \times A) - (D \times B)} \right) \right] \times 100$$

where,

A = is the undiluted CO₂ concentration measured with NDIR in %

B = is the diluted CO₂ concentration measured with NDIR in %

C = is the diluted NO concentration measured with (H)CLD in ppm

D = is the undiluted NO concentration measured with (H)CLD in ppm

Alternative methods of diluting and quantifying of CO₂ and NO span gas values such as dynamic mixing/blending can be used.

1.9.2.2. Water quench check

This check applies to wet gas concentration measurements only. Calculation of water quench must consider dilution of the NO span gas with water vapour and scaling of water vapour concentration of the mixture to that expected during testing.

A NO span gas having a concentration of 80 to 100 % of full scale of the normal operating range shall be passed through the (H)CLD and the NO value recorded as D. The NO span gas shall then be bubbled through water at room temperature and passed through the (H)CLD and the NO value recorded as C. The analyser's absolute operating pressure and the water temperature shall be determined and recorded as E and F, respectively. The mixture's saturation vapour pressure that corresponds to the bubbler water temperature F shall be determined and recorded as G. The water vapour concentration (H, in %) of the mixture shall be calculated as follows:

$$H = 100 \times (G/E)$$

The expected diluted NO span gas (in water vapour) concentration (D_e) shall be calculated as follows:

$$D_e = D \times (1 - H/100)$$

For diesel exhaust, the maximum exhaust water vapour concentration (H_m, in %) expected during testing shall be estimated, under the assumption of a fuel atom H/C ratio of 1,8:1, from the undiluted CO₂ span gas concentration (A, as measured in Section 1.9.2.1) as follows:

$$H_m = 0,9 \times A$$

The water quench, which must not be greater than 3 %, shall be calculated as follows:

$$\% \text{ quench} = 100 \times ((D_e - C)/D_e) \times (H_m/H)$$

where,

D _e	=	is the expected diluted NO concentration in ppm
C	=	is the diluted NO concentration in ppm
H _m	=	is the maximum water vapour concentration in %
H	=	is the actual water vapour concentration in %

Note: It is important that the NO span gas contains minimal NO₂ concentration for this check, since absorption of NO₂ in water has not been accounted for in the quench calculations.

1.10. Calibration intervals

The analysers shall be calibrated according to Section 1.5 at least every three months or whenever a system repair or change is made that could influence calibration.

2. CALIBRATION OF THE CVS-SYSTEM

2.1. General

The CVS system shall be calibrated by using an accurate flowmeter traceable to national or international standards and a restricting device. The flow through the system shall be measured at different restriction settings, and the control parameters of the system shall be measured and related to the flow.

Various types of flowmeters may be used, e.g. calibrated venturi, calibrated laminar flowmeter, calibrated turbinometer.

2.2. Calibration of the Positive Displacement Pump (PDP)

All parameters related to the pump shall be simultaneously measured with the parameters related to the flowmeter which is connected in series with the pump. The calculated flow rate (in m³/min at pump inlet, absolute pressure and temperature) shall be plotted versus a correlation function which is the value of a specific combination of pump parameters. The linear equation which relates the pump flow and the correlation function shall then be determined. If a CVS has a multiple speed drive, the calibration shall be performed for each range used. Temperature stability shall be maintained during calibration.

2.2.1. Data analysis

The air flowrate (Q_s) at each restriction setting (minimum six settings) shall be calculated in standard m³/min from the flowmeter data using the manufacturer's prescribed method. The air flow rate shall then be converted to pump flow (V_0) in m³/rev at absolute pump inlet temperature and pressure as follows:

$$V_0 = \frac{Q_s}{n} \times \frac{T}{273} \times \frac{101,3}{P_A}$$

where,

Q_s	=	air flow rate at standard conditions (101,3 kPa, 273 K), m ³ /s
T	=	temperature at pump inlet, K
P_A	=	absolute pressure at pump inlet ($p_B - p_1$), kPa
n	=	pump speed, rev/s

To account for the interaction of pressure variations at the pump and the pump slip rate, the correlation function (X_0) between pump speed, pressure differential from pump inlet to pump outlet and absolute pump outlet pressure shall be calculated as follows:

$$X_0 = \frac{1}{n} \times \sqrt{\frac{\Delta p_p}{P_A}}$$

where,

Δp_p	=	pressure differential from pump inlet to pump outlet, kPa
P_A	=	absolute outlet pressure at pump outlet, kPa

A linear least-square fit shall be performed to generate the calibration equation as follows:

$$V_0 = D_0 - m \times (X_0)$$

D_0 and m are the intercept and slope constants, respectively, describing the regression lines.

For a CVS system with multiple speeds, the calibration curves generated for the different pump flow ranges shall be approximately parallel, and the intercept values (D_0) shall increase as the pump flow range decreases.

The calculated values from the equation shall be within $\pm 0,5$ % of the measured value of V_0 . Values of m will vary from one pump to another. Particulate influx over time will cause the pump slip to decrease, as reflected by lower values for m . Therefore, calibration shall be performed at pump start-up, after major maintenance, and if the total system verification (Section 2.4) indicates a change of the slip rate.

2.3. Calibration of the Critical Flow Venturi (CFV)

Calibration of the CFV is based upon the flow equation for a critical venturi. Gas flow is a function of inlet pressure and temperature, as shown below:

$$Q_s = K_v \times \frac{p_A}{\sqrt{T}}$$

where,

K_v	= calibration coefficient
p_A	= absolute pressure at venturi inlet, kPa
T	= temperature at venturi inlet, K

2.3.1. Data analysis

The air flowrate (Q_s) at each restriction setting (minimum eight settings) shall be calculated in standard m^3/min from the flowmeter data using the manufacturer's prescribed method. The calibration coefficient shall be calculated from the calibration data for each setting as follows:

$$K_v = Q_s \times \frac{\sqrt{T}}{p_A}$$

where,

Q_s	= air flow rate at standard conditions (101,3 kPa, 273 K), m^3/s
T	= temperature at the venturi inlet, K
p_A	= absolute pressure at venturi inlet, kPa

To determine the range of critical flow, K_v shall be plotted as a function of venturi inlet pressure. For critical (choked) flow, K_v will have a relatively constant value. As pressure decreases (vacuum increases), the venturi becomes unchoked and K_v decreases, which indicates that the CFV is operated outside the permissible range.

For a minimum of eight points in the region of critical flow, the average K_v and the standard deviation shall be calculated. The standard deviation shall not exceed $\pm 0,3$ % of the average K_v .

2.4. Total system verification

The total accuracy of the CVS sampling system and analytical system shall be determined by introducing a known mass of a pollutant gas into the system while it is being operated in the normal manner. The pollutant is analysed, and the mass calculated according to Annex III, Appendix 2, Section 4.3 except in the case of propane where a factor of 0,000472 is used in place of 0,000479 for HC. Either of the following two techniques shall be used.

2.4.1. Metering with a critical flow orifice

A known quantity of pure gas (carbon monoxide or propane) shall be fed into the CVS system through a calibrated critical orifice. If the inlet pressure is high enough, the flow rate, which is adjusted by means of the critical flow orifice, is independent of the orifice outlet pressure (\equiv critical flow). The CVS system shall be operated as in a normal exhaust emission test for about 5 to 10 minutes. A gas sample shall be analysed with the usual equipment (sampling bag or integrating method), and the mass of the gas calculated. The mass so determined shall be within ± 3 % of the known mass of the gas injected.

2.4.2. Metering by means of a gravimetric technique

The weight of a small cylinder filled with carbon monoxide or propane shall be determined with a precision of $\pm 0,01$ gram. For about 5 to 10 minutes, the CVS system shall be operated as in a normal exhaust emission test, while carbon monoxide or propane is injected into the system. The quantity of pure gas discharged shall be determined by means of differential weighing. A gas sample shall be analysed with the usual equipment (sampling bag or integrating method), and the mass of the gas calculated. The mass so determined shall be within ± 3 % of the known mass of the gas injected.

3. CALIBRATION OF THE PARTICULATE MEASURING SYSTEM

3.1. Introduction

Each component shall be calibrated as often as necessary to fulfil the accuracy requirements of this Directive. The calibration method to be used is described in this section for the components indicated in Annex III, Appendix 4, Section 4 and Annex V, Section 2.

3.2. Flow measurement

The calibration of gas flow meters or flow measurement instrumentation shall be traceable to international and/or national standards. The maximum error of the measured value shall be within $\pm 2\%$ of reading.

If the gas flow is determined by differential flow measurement, the maximum error of the difference shall be such that the accuracy of G_{EDF} is within $\pm 4\%$ (see also Annex V, Section 2.2.1, EGA). It can be calculated by taking the Root-Mean-Square of the errors of each instrument.

3.3. Checking the partial flow conditions

The range of the exhaust gas velocity and the pressure oscillations shall be checked and adjusted according to the requirements of Annex V, Section 2.2.1, EP, if applicable.

3.4. Calibration intervals

The flow measurement instrumentation shall be calibrated at least every three months or whenever a system repair or change is made that could influence calibration.

4. CALIBRATION OF THE SMOKE MEASUREMENT EQUIPMENT

4.1. Introduction

The opacimeter shall be calibrated as often as necessary to fulfil the accuracy requirements of this Directive. The calibration method to be used is described in this section for the components indicated in Annex III, Appendix 4, Section 5 and Annex V, Section 3.

4.2. Calibration procedure

4.2.1. Warming-up time

The opacimeter shall be warmed up and stabilised according to the manufacturer's recommendations. If the opacimeter is equipped with a purge air system to prevent sooting of the instrument optics, this system should also be activated and adjusted according to the manufacturer's recommendations.

4.2.2. Establishment of the linearity response

The linearity of the opacimeter shall be checked in the opacity readout mode as per the manufacturer's recommendations. Three neutral density filters of known transmittance, which shall meet the requirements of Annex III, Appendix 4, Section 5.2.5, shall be introduced to the opacimeter and the value recorded. The neutral density filters shall have nominal opacities of approximately 10 %, 20 % and 40 %.

The linearity must not differ by more than $\pm 2\%$ opacity from the nominal value of the neutral density filter. Any non-linearity exceeding the above value must be corrected prior to the test.

4.3. Calibration intervals

The opacimeter shall be calibrated according to Section 4.2.2 at least every three months or whenever a system repair or change is made that could influence calibration.

ANNEX IV

TECHNICAL CHARACTERISTICS OF REFERENCE FUEL PRESCRIBED
FOR APPROVAL TESTS AND TO VERIFY CONFORMITY OF PRODUCTION

1.1. DIESEL FUEL⁰

Parameter	Unit	Limits ^b		Test method	Publication
		Minimum	Maximum		
Cetane number ^c		52	54	EN-ISO 5165	1998 ^d
Density at 15 °C	kg/m ³	833	837	EN-ISO 3675	1995
Distillation:					
— 50 % point	°C	245	—	EN-ISO 3405	1998
— 95 % point	°C	345	350	EN-ISO 3405	1998
— final boiling point	°C	—	370	EN-ISO 3405	1998
Flash point	°C	55	—	EN 27719	1993
CFPP	°C	—	- 5	EN 116	1981
Viscosity at 40 °C	mm ² /s	2,5	3,5	EN-ISO 3104	1996
Polycyclic aromatic hydrocarbons	% m/m	3,0	6,0	IP 391 ^g	1995
Sulphur content ^e	mg/kg	—	300	pr. EN-ISO/DIS 14596	1998 ^d
Copper corrosion		—	1	EN-ISO 2160	1995
Conradson carbon residue (10 % DR)	% m/m	—	0,2	EN-ISO 10370	
Ash content	% m/m	—	0,01	EN-ISO 6245	1995

Status: This is the original version (as it was originally adopted).

Water content	% m/m	—	0,05	EN-ISO 12937	1995
Neutralisation (strong acid) number	mg KOH/g	—	0,02	ASTM D 974-95	1998 ^d
Oxidation stability ^f	mg/ml	—	0,025	EN-ISO 12205	1996
	% m/m	—	—	EN 12916	[2000] ^d

a If it is required to calculate the thermal efficiency of an engine or vehicle, the calorific value of the fuel can be calculated from:

$$\text{Specific energy (calorific value)(net) in MJ/kg} = (46,423 - 8,792d^2 + 3,170d)(1 - (x + y + s)) + 9,420s - 2,499x$$

where,

d = the density at 15 °C

x = the proportion by mass of water (% divided by 100)

y = the proportion by mass of ash (% divided by 100)

s = the proportion by mass of sulphur (% divided by 100).

b The values quoted in the specification are 'true values'. In establishment of their limit values the terms of ISO 4259, Petroleum products — Determination and application of precision data in relation to methods of test, have been applied and in fixing a minimum value, a minimum difference of 2R above zero has been taken into account; in fixing a maximum and minimum value, the minimum difference is 4R (R = reproducibility). Notwithstanding this measure, which is necessary for statistical reasons, the manufacturer of a fuel should nevertheless aim at a zero value where the stipulated maximum value is 2R and at the mean value in the case of quotations of maximum and minimum limits. Should it be necessary to clarify the question as to whether a fuel meets the requirements of the specification, the terms of ISO 4259 should be applied.

c The range for cetane number is not in accordance with the requirement of a minimum range of 4R. However, in the case of dispute between fuel supplier and fuel user, the terms in ISO 4259 can be used to resolve such disputes provided replicate measurements, of sufficient number to achieve the necessary precision, are made in preference to single determinations.

d The month of publication will be completed in due course.

e The actual sulphur content of the fuel used for the test shall be reported. In addition, the sulphur content of the reference fuel used to approve a vehicle or engine against the limit values set out in row B of the Table in Section 6.2.1. of Annex I to this Directive shall have a maximum sulphur content of 50 ppm. The Commission will as soon as possible bring forward a modification to this Annex reflecting the market average for fuel sulphur content in respect of the fuel defined in Annex IV to Directive 98/70/EC.

f Even though oxidation stability is controlled, it is likely that shelf life will be limited. Advice should be sought from the supplier as to storage conditions and life.

g New and better method for polycyclic aromatics under development

1.2.

ETHANOL FOR DIESEL ENGINES⁰

Parameter	Unit	Limits ^b		Test method ^c
		Minimum	Maximum	
Alcohol, mass	% m/m	92,4	—	ASTM D 5501
Other alcohol than ethanol contained in total alcohol, mass	% m/m	—	2	ADTM D 5501
Density at 15 °C	kg/m ³	795	815	ASTM D 4052

Status: This is the original version (as it was originally adopted).

Ash content	% m/m		0,001	ISO 6245
Flash point	°C	10		ISO 2719
Acidity, calculated as acetic acid	% m/m	—	0,0025	ISO 1388-2
Neutralisation (strong acid) number	KOH mg/l	—	1	
Colour	According to scale	—	10	ASTM D 1209
Dry residue at 100 °C	mg/kg		15	ISO 759
Water content	% m/m		6,5	ISO 760
Aldehydes calculated as acetic acid	% m/m		0,0025	ISO 1388-4
Sulphur content	mg/kg	—	10	ASTM D 5453
Esters, calculated as ethylacetate	% m/m	—	0,1	ASSTM D 1617

a Cetane improver, as specified by the engine manufacturer, may be added to the ethanol fuel. The maximum allowed amount is 10 % m/m.

b The values quoted in the specification are 'true values'. In establishment of their limit values the terms of ISO 4259, Petroleum products — Determination and application of precision data in relation to methods of test, have been applied and in fixing a minimum value, a minimum difference of 2R above zero has been taken into account; in fixing a maximum and minimum value, the minimum difference is 4R (R – reproducibility). Notwithstanding this measure, which is necessary for statistical reasons, the manufacturer of a fuel should nevertheless aim at a zero value where the stipulated maximum value is 2R and at the mean value in the case of quotations of maximum and minimum limits. Should it be necessary to clarify the question as to whether a fuel meets the requirements of the specification, the terms of ISO 4259 should be applied.

c Equivalent ISO methods will be adopted when issued for all properties listed above.

2. NATURAL GAS (NG)

European market fuels are available in two ranges:

- the H range, whose extreme reference fuels are G_R and G₂₃;
- the L range, whose extreme reference fuels are G₂₃ and G₂₅.

The characteristics of G_R, G₂₃ and G₂₅ reference fuels are summarised below:

REFERENCE FUEL G_R

Characteristics	Units	Basis	Limits		Test method
			Minimum	Maximum	
a	Inerts +C ₂₊				
b	Value to be determined at standard conditions (293, 2 K (20 °C) and 101, 3 kPa).				

Status: This is the original version (as it was originally adopted).

Composition:					
Methane		87	84	89	
Ethane		13	11	15	
Balance ^a	%-mole	—	—	1	ISO 6974
Sulphur content	mg/m ^{3b}	—	—	10	ISO 6326-5

a Inerts +C₂₊

b Value to be determined at standard conditions (293,2 K (20 °C) and 101,3 kPa).

REFERENCE FUEL G₂₃

Characteristics	Units	Basis	Limits		Test method
			Minimum	Maximum	
Composition:					
Methane		92,5	91,5	93,5	
Balance ^a	%-mole	—	—	1	ISO 6974
N ₂		7,5	6,5	8,5	
Sulphur content	mg/m ^{3b}	—	—	10	ISO 6326-5

a Inerts (different from N₂) +C₂₊ +C₂₊.

b Value to be determined at standard conditions (293,2 K (20 °C) and 101,3 kPa).

REFERENCE FUEL G₂₅

Characteristics	Units	Basis	Limits		Test method
			Minimum	Maximum	
Composition:					
Methane		86	84	88	
Balance ^a	%-mole	—	—	1	ISO 6974
N ₂		14	12	16	
Sulphur content	mg/m ^{3b}	—	—	10	ISO 6326-5

a Inerts (different from N₂) +C₂₊ +C₂₊.

b Value to be determined at standard conditions (293,2 K (20 °C) and 101,3 kPa).

3. LIQUEFIED PETROLEUM GAS (LPG)

Status: This is the original version (as it was originally adopted).

Parameter	Unit	Limits fuel A		Limits fuel B		Test method
		Minimum	Maximum	Minimum	Maximum	
Motor octane number		92,5 ^a		92,5		EN 589 Annex B
Composition						
C ₃ content	% vol	48	52	83	87	
C ₄ content	% vol	48	52	13	17	ISO 7941
Olefins	% vol		12		14	
Evaporation residue	mg/kg		50		50	NFM 41015
Total sulphur content	ppm weight ^a		50		50	EN 24260
Hydrogen sulphide	—	None		None		ISO 8819
Copper strip corrosion	rating	class 1		class 1		ISO 6251 ^b
Water at 0 °C		free		free		Visual inspection

a Value to be determined at standard conditions 293,2 K (20 °C) and 101,3 kPa.

b This method may not accurately determine the presence of corrosive materials if the sample contains corrosion inhibitors or other chemicals which diminish the corrosivity of the sample to the copper strip. Therefore, the addition of such compounds for the sole purpose of biasing the test method is prohibited.

ANNEX V

ANALYTICAL AND SAMPLING SYSTEMS

1. DETERMINATION OF THE GASEOUS EMISSIONS

1.1. Introduction

Section 1.2 and Figures 7 and 8 contain detailed descriptions of the recommended sampling and analysing systems. Since various configurations can produce equivalent results, exact conformance with Figures 7 and 8 is not required. Additional components such as instruments, valves, solenoids, pumps, and switches may be used to provide additional information and coordinate the functions of the component systems. Other components which are not needed to maintain the accuracy on some systems, may be excluded if their exclusion is based upon good engineering judgement.

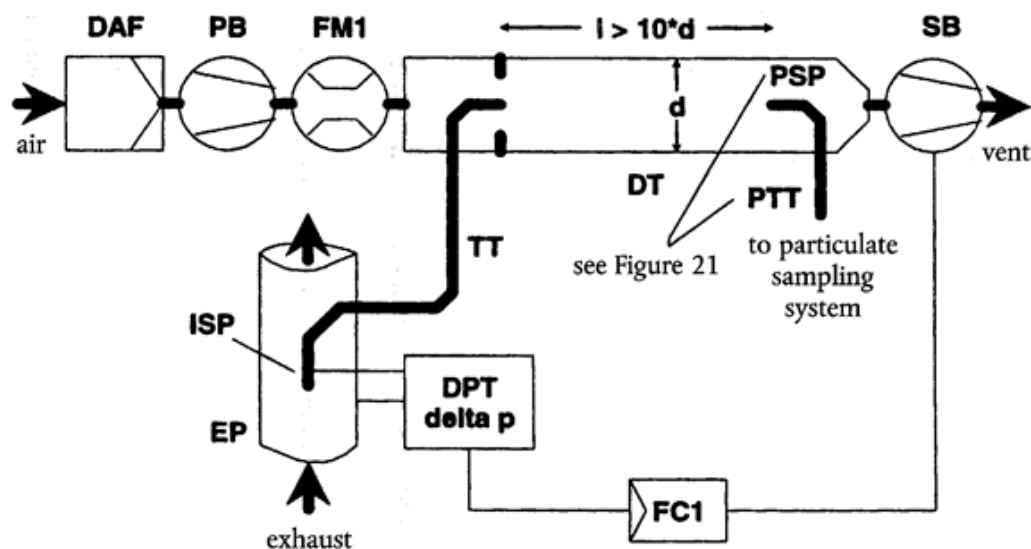

1.2. Description of the analytical system

An analytical system for the determination of the gaseous emissions in the raw (Figure 7, ESC only) or diluted (Figure 8, ETC and ESC) exhaust gas is described based on the use of:

- HFID analyser for the measurement of hydrocarbons;
- NDIR analysers for the measurement of carbon monoxide and carbon dioxide;
- HCLD or equivalent analyser for the measurement of the oxides of nitrogen.

The sample for all components may be taken with one sampling probe or with two sampling probes located in close proximity and internally split to the different analysers. Care must be taken that no condensation of exhaust components (including water and sulphuric acid) occurs at any point of the analytical system.

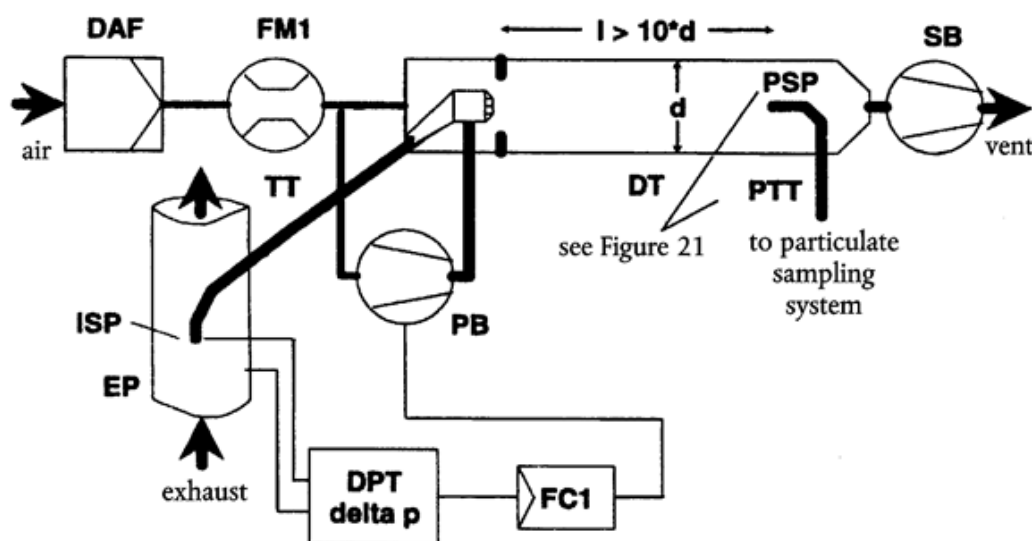

1.2.1. Components of Figures 7 and 8 Exhaust gas sampling probe (Figure 7 only)

A stainless steel straight closed end multi-hole probe is recommended. The inside diameter shall not be greater than the inside diameter of the sampling line. The wall thickness of the probe shall not be greater than 1 mm. There shall be a minimum of three holes in three different radial planes sized to sample approximately the same flow. The probe must extend across at least 80 % of the diameter of the exhaust pipe. One or two sampling probes may be used.

SP2 Diluted exhaust gas HC sampling probe (Figure 8 only)

The probe shall:

- be defined as the first 254 mm to 762 mm of the heated sampling line HSL1;
- have a 5 mm minimum inside diameter;
- be installed in the dilution tunnel DT (see Section 2.3, Figure 20) at a point where the dilution air and exhaust gas are well mixed (i.e. approximately 10 tunnel diameters downstream of the point where the exhaust enters the dilution tunnel);
- be sufficiently distant (radially) from other probes and the tunnel wall so as to be free from the influence of any wakes or eddies;
- be heated so as to increase the gas stream temperature to $463\text{ K} \pm 10\text{ K}$ ($190\text{ °C} \pm 10\text{ °C}$) at the exit of the probe.

SP3 Diluted exhaust gas CO, CO₂, NO_x sampling probe (Figure 8 only)

The probe shall:

- be in the same plane as SP2;
- be sufficiently distant (radially) from other probes and the tunnel wall so as to be free from the influence of any wakes or eddies;
- be heated and insulated over its entire length to a minimum temperature of 328 K (55 °C) to prevent water condensation.

HSL1 Heated sampling line

The sampling line provides a gas sample from a single probe to the split point(s) and the HC analyser.

The sampling line shall:

- have a 5 mm minimum and a 13,5 mm maximum inside diameter;
- be made of stainless steel or PTFE;
- maintain a wall temperature of $463\text{ K} \pm 10\text{ K}$ ($190\text{ °C} \pm 10\text{ °C}$) as measured at every separately controlled heated section, if the temperature of the exhaust gas at the sampling probe is equal to or below 463 K (190 °C);
- maintain a wall temperature greater than 453 K (180 °C), if the temperature of the exhaust gas at the sampling probe is above 463 K (190 °C);
- maintain a gas temperature of $463\text{ K} \pm 10\text{ K}$ ($190\text{ °C} \pm 10\text{ °C}$) immediately before the heated filter F2 and the HFID.

HSL2 Heated NO_x sampling line

The sampling line shall:

- maintain a wall temperature of 328 K to 473 K (55 °C to 200 °C), up to the converter C when using a cooling bath B, and up to the analyser when a cooling bath B is not used,
- be made of stainless steel or PTFE.

SL Sampling line for CO and CO₂

The line shall be made of PTFE or stainless steel. It may be heated or unheated.

BK Background bag (optional; Figure 8 only)

For the sampling of the background concentrations.

BG Sample bag (optional; Figure 8 CO and CO₂ only)

For the sampling of the sample concentrations.

F1 Heated pre-filter (optional)

The temperature shall be the same as HSL1.

F2 Heated filter

The filter shall extract any solid particles from the gas sample prior to the analyser. The temperature shall be the same as HSL1. The filter shall be changed as needed.

P Heated sampling pump

The pump shall be heated to the temperature of HSL1.

HC

Heated flame ionisation detector (HFID) for the determination of the hydrocarbons. The temperature shall be kept at 453 K to 473 K (180 °C to 200 °C).

CO, CO₂

NDIR analysers for the determination of carbon monoxide and carbon dioxide (optional for the determination of the dilution ratio for PT measurement).

NO

CLD or HCLD analyser for the determination of the oxides of nitrogen. If a HCLD is used it shall be kept at a temperature of 328 K to 473 K (55 °C to 200 °C).

C Converter

A converter shall be used for the catalytic reduction of NO₂ to NO prior to analysis in the CLD or HCLD.

B Cooling bath (optional)

To cool and condense water from the exhaust sample. The bath shall be maintained at a temperature of 273 K to 277 K (0 °C to 4 °C) by ice or refrigeration. It is optional if the analyser is free from water vapour interference as determined in Annex III, Appendix 5, Sections 1.9.1 and 1.9.2. If water is removed by condensation, the sample gas temperature or dew point shall be monitored either within the water trap or downstream. The sample gas temperature or dew point must not exceed 280 K (7 °C). Chemical dryers are not allowed for removing water from the sample.

T1, T2, T3 Temperature sensor

To monitor the temperature of the gas stream.

T4 Temperature sensor

To monitor the temperature of the NO₂-NO converter.

T5 Temperature sensor

To monitor the temperature of the cooling bath.

G1, G2, G3 Pressure gauge

To measure the pressure in the sampling lines.

R1, R2 Pressure regulator

To control the pressure of the air and the fuel, respectively, for the HFID.

R3, R4, R5 Pressure regulator

To control the pressure in the sampling lines and the flow to the analysers.

FL1, FL2, FL3 Flowmeter

To monitor the sample by-pass flow rate.
FL4 to FL6 Flowmeter (optional)

To monitor the flow rate through the analysers.
V1 to V5 Selector valve

Suitable valving for selecting sample, span gas or zero gas flow to the analysers.
V6, V7 Solenoid valve

To by-pass the NO₂-NO converter.
V8 Needle valve

To balance the flow through the NO₂-NO converter C and the by-pass.
V9, V10 Needle valve

To regulate the flows to the analysers.
V11, V12 Toggle valve (optional)

To drain the condensate from the bath B.

1.3. NMHC analysis (NG fuelled gas engines only)

1.3.1. Gas chromatographic method (GC, Figure 9)

When using the GC method, a small measured volume of a sample is injected onto an analytical column through which it is swept by an inert carrier gas. The column separates various components according to their boiling points so that they elute from the column at different times. They then pass through a detector which gives an electrical signal that depends on their concentration. Since it is not a continuous analysis technique, it can only be used in conjunction with the bag sampling method as described in Annex III, Appendix 4, Section 3.4.2.

For NMHC an automated GC with a FID shall be used. The exhaust gas shall be sampled into a sampling bag from which a part shall be taken and injected into the GC. The sample is separated into two parts (CH₄/Air/CO and NMHC/CO₂/H₂O) on the Porapak column. The molecular sieve column separates CH₄ from the air and CO before passing it to the FID where its concentration is measured. A complete cycle from injection of one sample to injection of a second can be made in 30 s. To determine NMHC, the CH₄ concentration shall be subtracted from the total HC concentration (see Annex III, Appendix 2, Section 4.3.1).

Figure 9 shows a typical GC assembled to routinely determine CH₄. Other GC methods can also be used based on good engineering judgement.

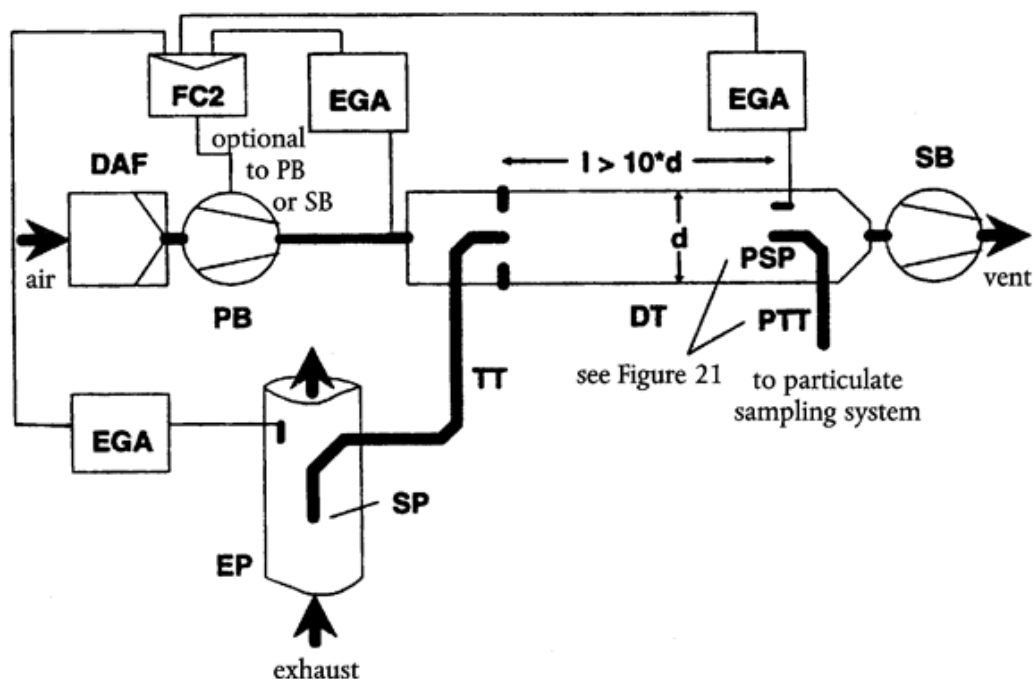

Components of Figure 9

PC Porapak column

Porapak N, 180/300 μm (50/80 mesh), 610 mm length \times 2,16 mm ID shall be used and conditioned at least 12 h at 423 K (150 $^{\circ}\text{C}$) with carrier gas prior to initial use.

MSC Molecular sieve column

Type 13X, 250/350 μm (45/60 mesh), 1 220 mm length \times 2,16 mm ID shall be used and conditioned at least 12 h at 423 K (150 $^{\circ}\text{C}$) with carrier gas prior to initial use.

OV Oven

To maintain columns and valves at stable temperature for analyser operation, and to condition the columns at 423 K (150 $^{\circ}\text{C}$).

SLP Sample loop

A sufficient length of stainless steel tubing to obtain approximately 1 cm^3 volume.

P Pump

To bring the sample to the gas chromatograph.

D Dryer

A dryer containing a molecular sieve shall be used to remove water and other contaminants which might be present in the carrier gas.

HC

Flame ionisation detector (FID) to measure the concentration of methane.

V1 Sample injection valve

To inject the sample taken from the sampling bag via SL of Figure 8. It shall be low dead volume, gas tight, and heatable to 423 K (150 C).

V3 Selector valve

To select span gas, sample, or no flow.

V2, V4, V5, V6, V7, V8 Needle valve

To set the flows in the system.

R1, R2, R3 Pressure regulator

To control the flows of the fuel (= carrier gas), the sample, and the air, respectively.

FC Flow capillary

To control the rate of air flow to the FID.

G1, G2, G3 Pressure gauge

To control the flows of the fuel (= carrier gas), the sample, and the air, respectively.

F1, F2, F3, F4, F5 Filter

Sintered metal filters to prevent grit from entering the pump or the instrument.

FL1

To measure the sample by-pass flow rate.

1.3.2. Non-methane cutter method (NMC, Figure 10)

The cutter oxidises all hydrocarbons except CH₄ to CO₂ and H₂O, so that by passing the sample through the NMC only CH₄ is detected by the FID. If bag sampling is used, a flow diverter system shall be installed at SL (see Section 1.2, Figure 8) with which the flow can be alternatively passed through or around the cutter according to the upper part of Figure 10. For NMHC measurement, both values (HC and CH₄) shall be observed on the FID and recorded. If the integration method is used, an NMC in line with a second FID shall be installed parallel to the regular FID into HSL1 (see Section 1.2, Figure 8) according to the lower part of Figure 10. For NMHC measurement, the values of the two FID's (HC and CH₄) shall be observed and recorded.

The cutter shall be characterised at or above 600 K (327 °C) prior to test work with respect to its catalytic effect on CH₄ and C₂H₆ at H₂O values representative of exhaust stream conditions. The dewpoint and O₂ level of the sampled exhaust stream must be known. The relative response of the FID to CH₄ must be recorded (see Annex III, Appendix 5, Section 1.8.2).

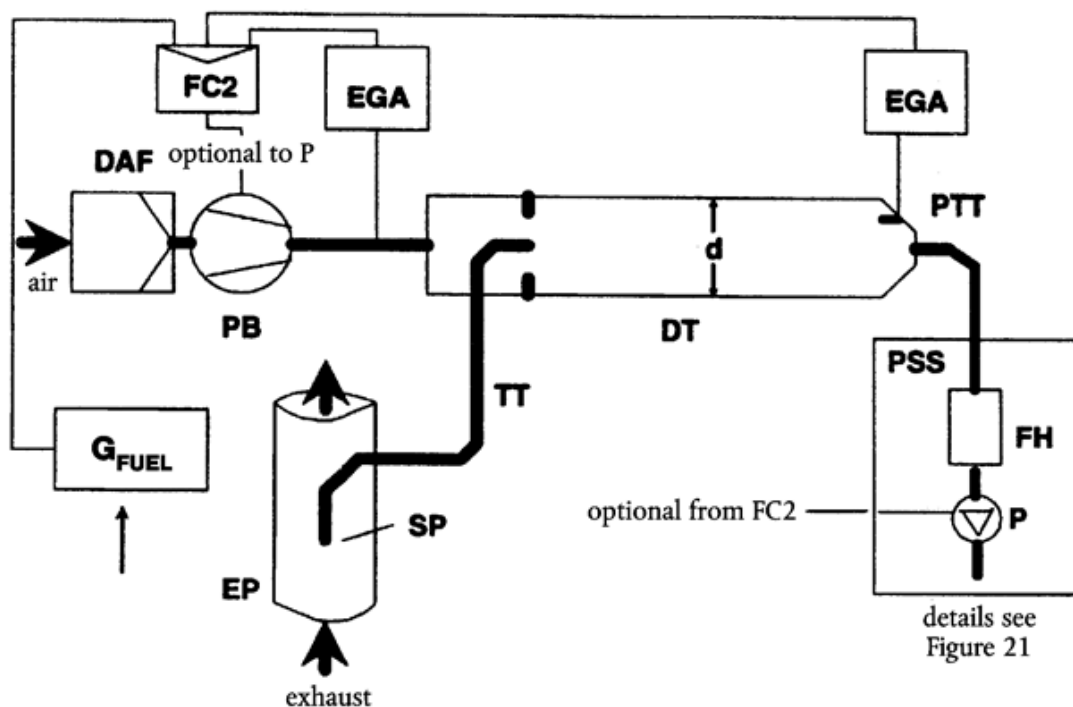

Components of Figure 10
NMC Non-methane cutter

To oxidise all hydrocarbons except methane.
HC

Heated flame ionisation detector (HFID) to measure the HC and CH₄ concentrations. The temperature shall be kept at 453 K to 473 K (180 °C to 200 °C).

V1 Selector valve

To select sample, zero and span gas. V1 is identical with V2 of Figure 8.

V2, V3 Solenoid valve

To by-pass the NMC.

V4 Needle valve

To balance the flow through the NMC and the by-pass.

R1 Pressure regulator

To control the pressure in the sampling line and the flow to the HFID. R1 is identical with R3 of Figure 8.

FL1 Flowmeter

To measure the sample by-pass flow rate. FL1 is identical with FL1 of Figure 8.

2. EXHAUST GAS DILUTION AND DETERMINATION OF THE PARTICULATES

2.1. Introduction

Sections 2.2, 2.3 and 2.4 and Figures 11 to 22 contain detailed descriptions of the recommended dilution and sampling systems. Since various configurations can produce equivalent results, exact conformance with these figures is not required. Additional components such as

instruments, valves, solenoids, pumps, and switches may be used to provide additional information and coordinate the functions of the component systems. Other components which are not needed to maintain the accuracy on some systems, may be excluded if their exclusion is based upon good engineering judgement.

2.2. Partial flow dilution system

A dilution system is described in Figures 11 to 19 based upon the dilution of a part of the exhaust stream. Splitting of the exhaust stream and the following dilution process may be done by different dilution system types. For subsequent collection of the particulates, the entire dilute exhaust gas or only a portion of the dilute exhaust gas is passed to the particulate sampling system (Section 2.4, Figure 21). The first method is referred to as total sampling type, the second method as fractional sampling type.

The calculation of the dilution ratio depends upon the type of system used. The following types are recommended:

Isokinetic systems (Figures 11, 12)

With these systems, the flow into the transfer tube is matched to the bulk exhaust flow in terms of gas velocity and/or pressure, thus requiring an undisturbed and uniform exhaust flow at the sampling probe. This is usually achieved by using a resonator and a straight approach tube upstream of the sampling point. The split ratio is then calculated from easily measurable values like tube diameters. It should be noted that isokinetic is only used for matching the flow conditions and not for matching the size distribution. The latter is typically not necessary, as the particles are sufficiently small as to follow the fluid streamlines.

Flow controlled systems with concentration measurement (Figures 13 to 17)

With these systems, a sample is taken from the bulk exhaust stream by adjusting the dilution air flow and the total dilute exhaust flow. The dilution ratio is determined from the concentrations of tracer gases, such as CO₂ or NO_x naturally occurring in the engine exhaust. The concentrations in the dilute exhaust gas and in the dilution air are measured, whereas the concentration in the raw exhaust gas can be either measured directly or determined from fuel flow and the carbon balance equation, if the fuel composition is known. The systems may be controlled by the calculated dilution ratio (Figures 13, 14) or by the flow into the transfer tube (Figures 12, 13, 14).

Flow controlled systems with flow measurement (Figures 18, 19)

With these systems, a sample is taken from the bulk exhaust stream by setting the dilution air flow and the total dilute exhaust flow. The dilution ratio is determined from the difference of the two flows rates. Accurate calibration of the flow meters relative to one another is required, since the relative magnitude of the two flow rates can lead to significant errors at higher dilution ratios (of 15 and above). Flow control is very straight forward by keeping the dilute exhaust flow rate constant and varying the dilution air flow rate, if needed.

When using partial flow dilution systems, attention must be paid to avoiding the potential problems of loss of particulates in the transfer tube, ensuring that a representative sample is taken from the engine exhaust, and determination of the split ratio. The systems described pay attention to these critical areas.

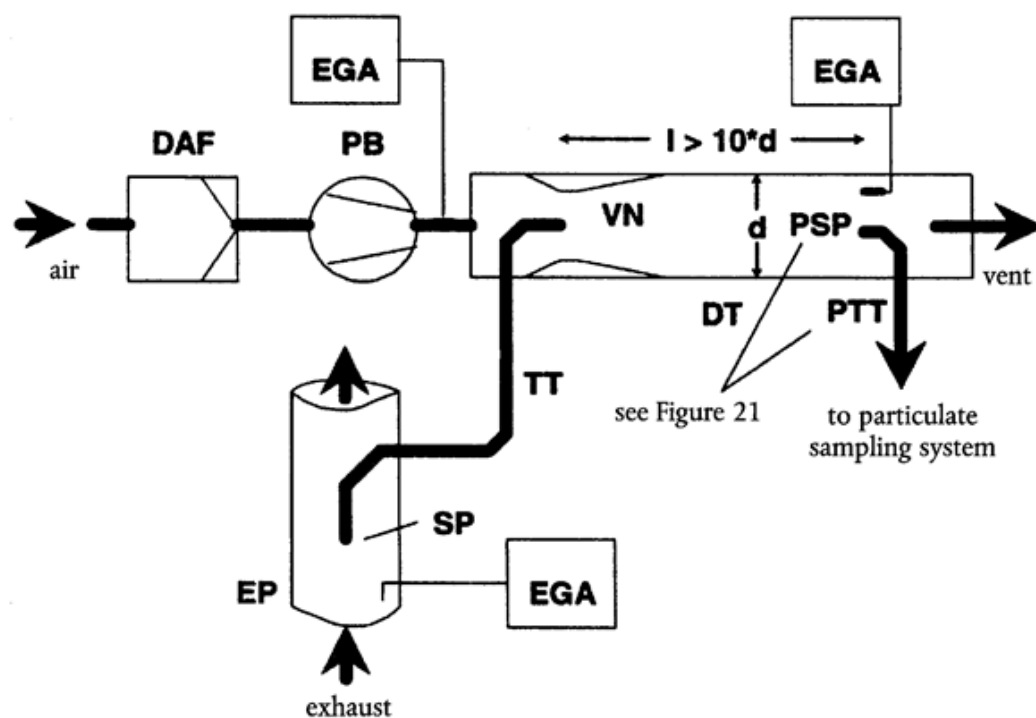

Raw exhaust gas is transferred from the exhaust pipe EP to the dilution tunnel DT through the transfer tube TT by the isokinetic sampling probe ISP. The differential pressure of the exhaust gas between exhaust pipe and inlet to the probe is measured with the pressure transducer DPT. This signal is transmitted to the flow controller FC1 that controls the suction blower SB to maintain a differential pressure of zero at the tip of the probe. Under these conditions, exhaust gas velocities in EP and ISP are identical, and the flow through ISP and TT is a constant fraction (split) of the exhaust gas flow. The split ratio is determined from the cross-sectional areas of EP and ISP. The dilution air flow rate is measured with the flow measurement device FM1. The dilution ratio is calculated from the dilution air flow rate and the split ratio.

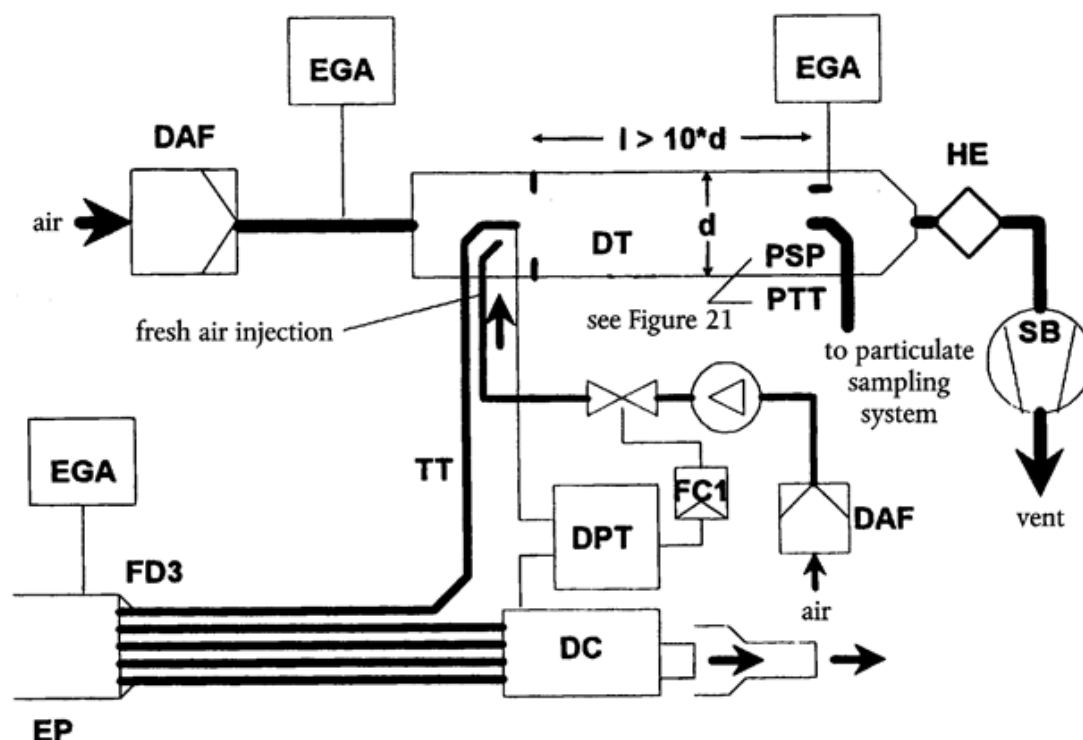

Raw exhaust gas is transferred from the exhaust pipe EP to the dilution tunnel DT through the sampling probe SP and the transfer tube TT. The concentrations of a tracer gas (CO_2 or NO_x) are measured in the raw and diluted exhaust gas as well as in the dilution air with the exhaust gas analyser(s) EGA. These signals are transmitted to the flow controller FC2 that controls either the pressure blower PB or the suction blower SB to maintain the desired exhaust split and dilution ratio in DT. The dilution ratio is calculated from the tracer gas concentrations in the raw exhaust gas, the diluted exhaust gas, and the dilution air.

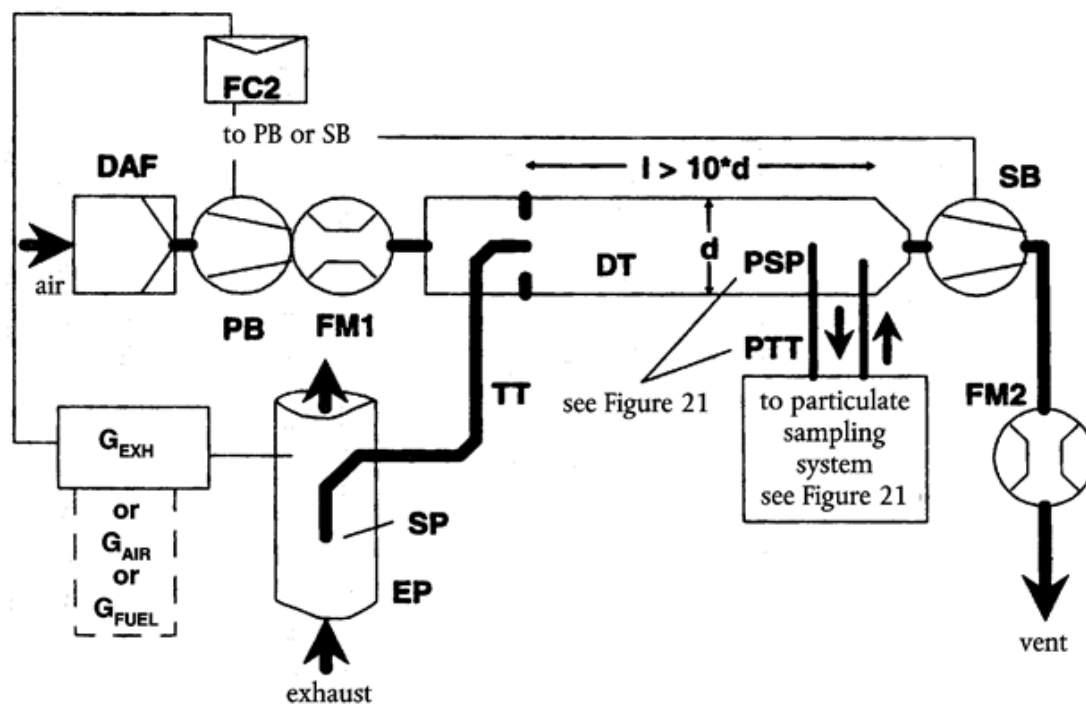

Raw exhaust gas is transferred from the exhaust pipe EP to the dilution tunnel DT through the sampling probe SP and the transfer tube TT due to the negative pressure created by the venturi VN in DT. The gas flow rate through TT depends on the momentum exchange at the venturi zone, and is therefore affected by the absolute temperature of the gas at the exit of TT. Consequently, the exhaust split for a given tunnel flow rate is not constant, and the dilution ratio at low load is slightly lower than at high load. The tracer gas concentrations (CO_2 or NO_x) are measured in the raw exhaust gas, the diluted exhaust gas, and the dilution air with the exhaust gas analyser(s) EGA, and the dilution ratio is calculated from the values so measured.

Status: This is the original version (as it was originally adopted).

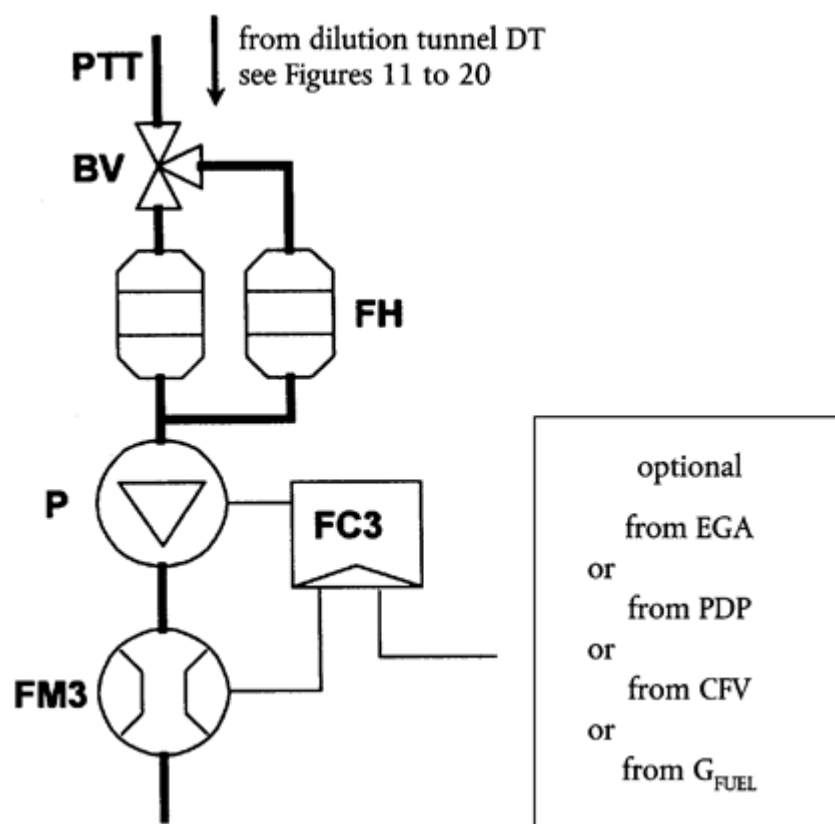

Raw exhaust gas is transferred from the exhaust pipe EP to the dilution tunnel DT through the transfer tube TT by the flow divider FD3 that consists of a number of tubes of the same dimensions (same diameter, length and bend radius) installed in EP. The exhaust gas through one of these tubes is lead to DT, and the exhaust gas through the rest of the tubes is passed through the damping chamber DC. Thus, the exhaust split is determined by the total number of tubes. A constant split control requires a differential pressure of zero between DC and the outlet of TT, which is measured with the differential pressure transducer DPT. A differential pressure of zero is achieved by injecting fresh air into DT at the outlet of TT. The tracer gas concentrations (CO_2 or NO_x) are measured in the raw exhaust gas, the diluted exhaust gas, and the dilution air with the exhaust gas analyser(s) EGA. They are necessary for checking the exhaust split and may be used to control the injection air flow rate for precise split control. The dilution ratio is calculated from the tracer gas concentrations.

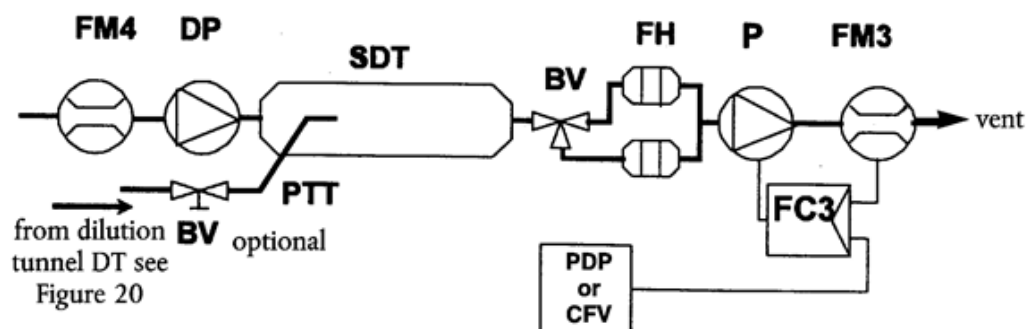

Raw exhaust gas is transferred from the exhaust pipe EP to the dilution tunnel DT through the sampling probe SP and the transfer tube TT. The total flow through the tunnel is adjusted with the flow controller FC3 and the sampling pump P of the particulate sampling system (see Figure 18). The dilution air flow is controlled by the flow controller FC2, which may use G_{EXHW} , G_{AIRW} , or G_{FUEL} as command signals, for the desired exhaust split. The sample flow into DT is the difference of the total flow and the dilution air flow. The dilution air flow rate is measured with the flow measurement device FM1, the total flow rate with the flow measurement device FM3 of the particulate sampling system (see Figure 21). The dilution ratio is calculated from these two flow rates.

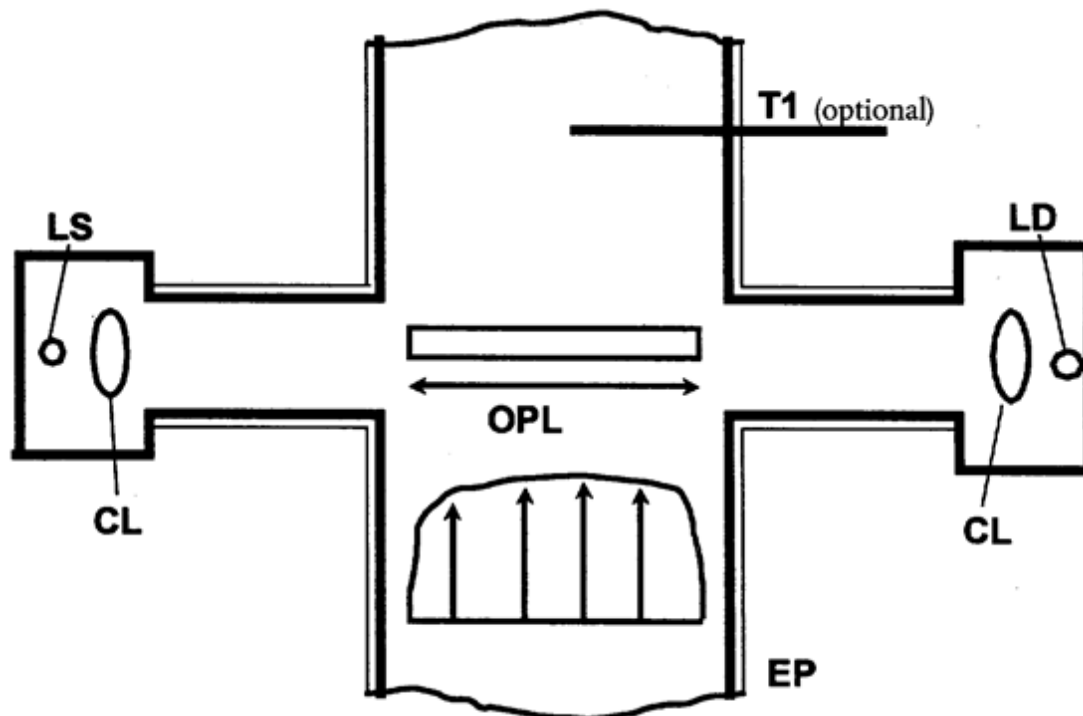

Raw exhaust gas is transferred from the exhaust pipe EP to the dilution tunnel DT through the sampling probe SP and the transfer tube TT. The exhaust split and the flow into DT is controlled by the flow controller FC2 that adjusts the flows (or speeds) of the pressure blower PB and the suction blower SB, accordingly. This is possible since the sample taken with the particulate sampling system is returned into DT. G_{EXHW} , G_{AIRW} , or G_{FUEL} may be used as command signals for FC2. The dilution air flow rate is measured with the flow measurement device FM1, the total flow with the flow measurement device FM2. The dilution ratio is calculated from these two flow rates.

2.2.1. Components of Figures 11 to 19 EP Exhaust pipe

The exhaust pipe may be insulated. To reduce the thermal inertia of the exhaust pipe a thickness to diameter ratio of 0,015 or less is recommended. The use of flexible sections shall be limited to a length to diameter ratio of 12 or less. Bends shall be minimised to reduce inertial deposition. If the system includes a test bed silencer the silencer may also be insulated.

For an isokinetic system, the exhaust pipe must be free of elbows, bends and sudden diameter changes for at least 6 pipe diameters upstream and 3 pipe diameters downstream of the tip of the probe. The gas velocity at the sampling zone must be higher than 10 m/s except at idle

mode. Pressure oscillations of the exhaust gas must not exceed ± 500 Pa on the average. Any steps to reduce pressure oscillations beyond using a chassis-type exhaust system (including silencer and aftertreatment devices) must not alter engine performance nor cause the deposition of particulates.

For systems without isokinetic probe, it is recommended to have a straight pipe of 6 pipe diameters upstream and 3 pipe diameters downstream of the tip of the probe.

SP Sampling probe (Figures 10, 14, 15, 16, 18, 19)

The minimum inside diameter shall be 4 mm. The minimum diameter ratio between exhaust pipe and probe shall be 4. The probe shall be an open tube facing upstream on the exhaust pipe centreline, or a multiple hole probe as described under SP1 in Section 1.2.1, Figure 5.

ISP Isokinetic sampling probe (Figures 11, 12)

The isokinetic sampling probe must be installed facing upstream on the exhaust pipe centreline where the flow conditions in section EP are met, and designed to provide a proportional sample of the raw exhaust gas. The minimum inside diameter shall be 12 mm.

A control system is necessary for isokinetic exhaust splitting by maintaining a differential pressure of zero between EP and ISP. Under these conditions exhaust gas velocities in EP and ISP are identical and the mass flow through ISP is a constant fraction of the exhaust gas flow. ISP has to be connected to a differential pressure transducer DPT. The control to provide a differential pressure of zero between EP and ISP is done with the flow controller FC1.

FD1, FD2 Flow divider (Figure 16)

A set of venturis or orifices is installed in the exhaust pipe EP and in the transfer tube TT, respectively, to provide a proportional sample of the raw exhaust gas. A control system consisting of two pressure control valves PCV1 and PCV2 is necessary for proportional splitting by controlling the pressures in EP and DT.

FD3 Flow divider (Figure 17)

A set of tubes (multiple tube unit) is installed in the exhaust pipe EP to provide a proportional sample of the raw exhaust gas. One of the tubes feeds exhaust gas to the dilution tunnel DT, whereas the other tubes exit exhaust gas to a damping chamber DC. The tubes must have the same dimensions (same diameter, length, bend radius), so that the exhaust split depends on the total number of tubes. A control system is necessary for proportional splitting by maintaining a differential pressure of zero between the exit of the multiple tube unit into DC and the exit of TT. Under these conditions, exhaust gas velocities in EP and FD3 are proportional, and the flow TT is a constant fraction of the exhaust gas flow. The two points have to be connected to a differential pressure transducer DPT. The control to provide a differential pressure of zero is done with the flow controller FC1.

EGA Exhaust gas analyser (Figures 13, 14, 15, 16, 17)

CO₂ or NO_x analysers may be used (with carbon balance method CO₂ only). The analysers shall be calibrated like the analysers for the measurement of the gaseous emissions. One or several analysers may be used to determine the concentration differences. The accuracy of the measuring systems has to be such that the accuracy of G_{EDFW,i} is within ± 4 %.

TT Transfer tube (Figures 11 to 19)

The transfer tube shall be:

- as short as possible, but not more than 5 m in length,
- equal to or greater than the probe diameter, but not more than 25 mm in diameter,
- exiting on the centreline of the dilution tunnel and pointing downstream.

If the tube is 1 meter or less in length, it shall be insulated with material with a maximum thermal conductivity of 0,05 W/m*K with a radial insulation thickness corresponding to the diameter of the probe. If the tube is longer than 1 meter, it must be insulated and heated to a minimum wall temperature of 523 K (250 °C).

DPT Differential pressure transducer (Figures 11, 12, 17)

The differential pressure transducer shall have a range of ± 500 Pa or less.

FC1 Flow controller (Figures 11, 12, 17)

For isokinetic systems (Figures 11,12), a flow controller is necessary to maintain a differential pressure of zero between EP and ISP. The adjustment can be done by:

- (a) controlling the speed or flow of the suction blower SB and keeping the speed or flow of the pressure blower PB constant during each mode (Figure 11); or
- (b) adjusting the suction blower SB to a constant mass flow of the diluted exhaust gas and controlling the flow of the pressure blower PB, and therefore the exhaust sample flow in a region at the end of the transfer tube TT (Figure 12).

In the case of a pressure controlled system the remaining error in the control loop must not exceed ± 3 Pa. The pressure oscillations in the dilution tunnel must not exceed ± 250 Pa on the average.

For a multi-tube system (Figure 17), a flow controller is necessary for proportional exhaust splitting to maintain a differential pressure of zero between the exit of the multi-tube unit and the exit of TT. The adjustment is done by controlling the injection air flow rate into DT at the exit of TT.

PCV1, PCV2 Pressure control valve (Figure 16)

Two pressure control valves are necessary for the twin venturi/twin orifice system for proportional flow splitting by controlling the backpressure of EP and the pressure in DT. The valves shall be located downstream of SP in EP and between PB and DT.

DC Damping chamber (Figure 17)

A damping chamber shall be installed at the exit of the multiple tube unit to minimise the pressure oscillations in the exhaust pipe EP.

VN Venturi (Figure 15)

A venturi is installed in the dilution tunnel DT to create a negative pressure in the region of the exit of the transfer tube TT. The gas flow rate through TT is determined by the momentum exchange at the venturi zone, and is basically proportional to the flow rate of the pressure blower PB leading to a constant dilution ratio. Since the momentum exchange is affected by the temperature at the exit of TT and the pressure difference between EP and DT, the actual dilution ratio is slightly lower at low load than at high load.

FC2 Flow controller (Figures 13, 14, 18, 19, optional)

A flow controller may be used to control the flow of the pressure blower PB and/or the suction blower SB. It may be connected to the exhaust, intake air, or fuel flow signals and/or to the CO₂ or NO_x differential signals. When using a pressurised air supply (Figure 18), FC2 directly controls the air flow.

FM1 Flow measurement device (Figures 11, 12, 18, 19)

Gas meter or other flow instrumentation to measure the dilution air flow. FM1 is optional if the pressure blower PB is calibrated to measure the flow.

FM2 Flow measurement device (Figure 19)

Gas meter or other flow instrumentation to measure the diluted exhaust gas flow. FM2 is optional if the suction blower SB is calibrated to measure the flow.

PB Pressures blower (Figures 11, 12, 13, 14, 15, 16, 19)

To control the dilution air flow rate, PB may be connected to the flow controllers FC1 or FC2. PB is not required when using a butterfly valve. PB may be used to measure the dilution air flow, if calibrated.

SB Suction blower (Figures 11, 12, 13, 16, 17, 19)

For fractional sampling systems only. SB may be used to measure the diluted exhaust gas flow, if calibrated.

DAF Dilution air filter (Figures 11 to 19)

It is recommended that the dilution air be filtered and charcoal scrubbed to eliminate background hydrocarbons. At the engine manufacturers request the dilution air shall be sampled according to good engineering practice to determine the background particulate levels, which can then be subtracted from the values measured in the diluted exhaust.

DT Dilution tunnel (Figures 11 to 19)

The dilution tunnel:

- shall be of a sufficient length to cause complete mixing of the exhaust and dilution air under turbulent flow conditions;
- shall be constructed of stainless steel with:
 - thickness/diameter ratio of 0,025 or less for dilution tunnels with inside diameters greater than 75 mm;
 - a nominal thickness of no less than 1,5 mm for dilution tunnels with inside diameters of equal to or less than 75 mm;
- shall be at least 75 mm in diameter for the fractional sampling type;
- is recommended to be at least 25 mm in diameter for the total sampling type;
- may be heated to no greater than 325 K (52 °C) wall temperature by direct heating or by dilution air pre-heating, provided the air temperature does not exceed 325 K (52 °C) prior to the introduction of the exhaust in the dilution tunnel;
- may be insulated.

The engine exhaust shall be thoroughly mixed with the dilution air. For fractional sampling systems, the mixing quality shall be checked after introduction into service by means of a CO₂-profile of the tunnel with the engine running (at least four equally spaced measuring points). If necessary, a mixing orifice may be used.

Note: If the ambient temperature in the vicinity of the dilution tunnel (DT) is below 293K (20 °C), precautions should be taken to avoid particle losses onto the cool walls of the dilution tunnel. Therefore, heating and/or insulating the tunnel within the limits given above is recommended.

At high engine loads, the tunnel may be cooled by a non-aggressive means such as a circulating fan, as long as the temperature of the cooling medium is not below 293K (20 °C).

HE Heat exchanger (Figures 16, 17)

The heat exchanger shall be of sufficient capacity to maintain the temperature at the inlet to the suction blower SB within $\pm 11\text{K}$ of the average operating temperature observed during the test.

2.3. Full flow dilution system

A dilution system is described in Figure 20 based upon the dilution of the total exhaust using the CVS (Constant Volume Sampling) concept. The total volume of the mixture of exhaust and dilution air must be measured. Either a PDP or a CFV system may be used.

For subsequent collection of the particulates, a sample of the dilute exhaust gas is passed to the particulate sampling system (section 2.4, figures 21 and 22). If this is done directly, it is referred to as single dilution. If the sample is diluted once more in the secondary dilution tunnel, it is referred to as double dilution. This is useful, if the filter face temperature requirement cannot be met with single dilution. Although partly a dilution system, the double dilution system is described as a modification of a particulate sampling system in section 2.4, Figure 22, since it shares most of the parts with a typical particulate sampling system.

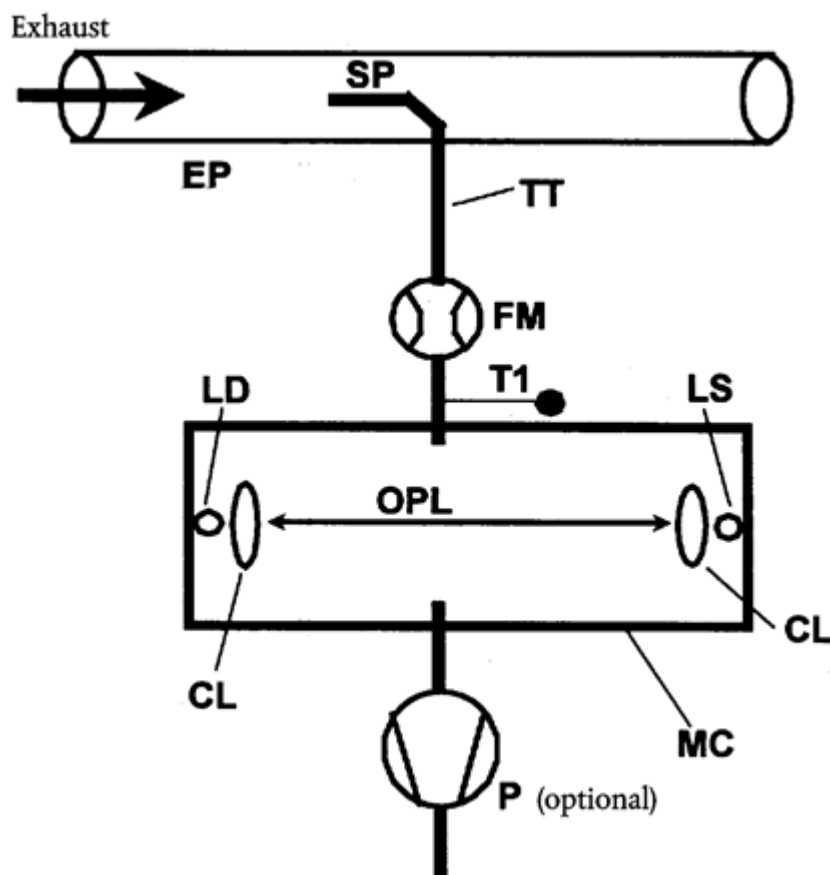

The total amount of raw exhaust gas is mixed in the dilution tunnel DT with the dilution air. The diluted exhaust gas flow rate is measured either with a Positive Displacement Pump PDP or with a Critical Flow Venturi CFV. A heat exchanger HE or electronic flow compensation EFC may be used for proportional particulate sampling and for flow determination. Since particulate mass determination is based on the total diluted exhaust gas flow, the dilution ratio is not required to be calculated.

2.3.1. Components of Figure 20

EP Exhaust pipe

The exhaust pipe length from the exit of the engine exhaust manifold, turbocharger outlet or aftertreatment device to the dilution tunnel shall not exceed 10 m. If the exhaust pipe downstream of the engine exhaust manifold, turbocharger outlet or aftertreatment device

exceeds 4 m in length, then all tubing in excess of 4 m shall be insulated, except for an in-line smokemeter, if used. The radial thickness of the insulation must be at least 25 mm. The thermal conductivity of the insulating material must have a value no greater than 0,1 W/mK measured at 673 K (400 °C). To reduce the thermal inertia of the exhaust pipe a thickness to diameter ratio of 0,015 or less is recommended. The use of flexible sections shall be limited to a length to diameter ratio of 12 or less.

PDP Positive displacement pump

The PDP meters total diluted exhaust flow from the number of the pump revolutions and the pump displacement. The exhaust system backpressure must not be artificially lowered by the PDP or dilution air inlet system. Static exhaust backpressure measured with the PDP system operating shall remain within $\pm 1,5$ kPa of the static pressure measured without connection to the PDP at identical engine speed and load. The gas mixture temperature immediately ahead of the PDP shall be within ± 6 K of the average operating temperature observed during the test, when no flow compensation is used. Flow compensation may only be used if the temperature at the inlet to the PDP does not exceed 323K (50 °C).

CFV Critical Flow Venturi

CFV measures total diluted exhaust flow by maintaining the flow at choked conditions (critical flow). Static exhaust backpressure measured with the CFV system operating shall remain within $\pm 1,5$ kPa of the static pressure measured without connection to the CFV at identical engine speed and load. The gas mixture temperature immediately ahead of the CFV shall be within ± 11 K of the average operating temperature observed during the test, when no flow compensation is used.

HE Heat exchanger (optional, if EFC is used)

The heat exchanger shall be of sufficient capacity to maintain the temperature within the limits required above.

EFC Electronic flow compensation (optional, if HE is used)

If the temperature at the inlet to either the PDP or CFV is not kept within the limits stated above, a flow compensation system is required for continuous measurement of the flow rate and control of the proportional sampling in the particulate system. To that purpose, the continuously measured flow rate signals are used to correct the sample flow rate through the particulate filters of the particulate sampling system (see Section 2.4, Figures 21, 22), accordingly.

DT Dilution tunnel

The dilution tunnel:

- shall be small enough in diameter to cause turbulent flow (Reynolds Number greater than 4 000) and of sufficient length to cause complete mixing of the exhaust and dilution air; a mixing orifice may be used;
- shall be at least 460 mm in diameter with a single dilution system;
- shall be at least 210 mm in diameter with a double dilution system;
- may be insulated.

The engine exhaust shall be directed downstream at the point where it is introduced into the dilution tunnel, and thoroughly mixed.

When using single dilution, a sample from the dilution tunnel is transferred to the particulate sampling system (Section 2.4, Figure 21). The flow capacity of the PDP or CFV must be sufficient to maintain the diluted exhaust at a temperature of less than or equal to 325 K (52 °C) immediately before the primary particulate filter.

When using double dilution, a sample from the dilution tunnel is transferred to the secondary dilution tunnel where it is further diluted, and then passed through the sampling filters (Section

2.4, Figure 22). The flow capacity of the PDP or CFV must be sufficient to maintain the diluted exhaust stream in the DT at a temperature of less than or equal to 464 K (191 °C) at the sampling zone. The secondary dilution system must provide sufficient secondary dilution air to maintain the doubly-diluted exhaust stream at a temperature of less than or equal to 325 K (52 °C) immediately before the primary particulate filter.

DAF Dilution air filter

It is recommended that the dilution air be filtered and charcoal scrubbed to eliminate background hydrocarbons. At the engine manufacturers request the dilution air shall be sampled according to good engineering practice to determine the background particulate levels, which can then be subtracted from the values measured in the diluted exhaust.

PSP Particulate sampling probe

The probe is the leading section of PTT and:

- shall be installed facing upstream at a point where the dilution air and exhaust gas are well mixed, i.e. on the dilution tunnel (DT) centreline approximately 10 tunnel diameters downstream of the point where the exhaust enters the dilution tunnel;
- shall be of 12 mm minimum inside diameter;
- may be heated to no greater than 325 K (52 °C) wall temperature by direct heating or by dilution air pre-heating, provided the air temperature does not exceed 325 K (52 °C) prior to the introduction of the exhaust in the dilution tunnel;
- may be insulated.

2.4. Particulate sampling system

The particulate sampling system is required for collecting the particulates on the particulate filter. In the case of total sampling partial flow dilution, which consists of passing the entire diluted exhaust sample through the filters, dilution (Section 2.2, Figures 14, 18) and sampling system usually form an integral unit. In the case of fractional sampling partial flow dilution or full flow dilution, which consists of passing through the filters only a portion of the diluted exhaust, the dilution (Section 2.2, Figures 11, 12, 13, 15, 16, 17, 19; Section 2.3, Figure 20) and sampling systems usually form different units.

In this Directive, the double dilution system (Figure 22) of a full flow dilution system is considered as a specific modification of a typical particulate sampling system as shown in Figure 21. The double dilution system includes all important parts of the particulate sampling system, like filter holders and sampling pump.

In order to avoid any impact on the control loops, it is recommended that the sample pump be running throughout the complete test procedure. For the single filter method, a bypass system shall be used for passing the sample through the sampling filters at the desired times. Interference of the switching procedure on the control loops must be minimised.

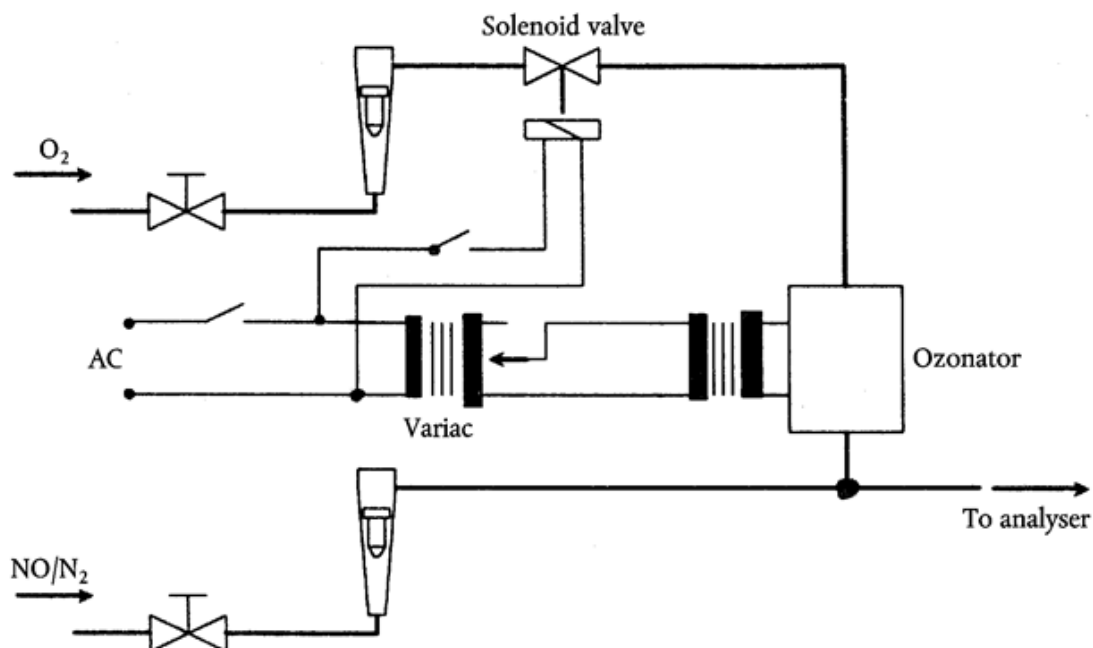

A sample of the diluted exhaust gas is taken from the dilution tunnel DT of a partial flow or full flow dilution system through the particulate sampling probe PSP and the particulate transfer tube PTT by means of the sampling pump P. The sample is passed through the filter holder(s) FH that contain the particulate sampling filters. The sample flow rate is controlled by the flow controller FC3. If electronic flow compensation EFC (see Figure 20) is used, the diluted exhaust gas flow is used as command signal for FC3.

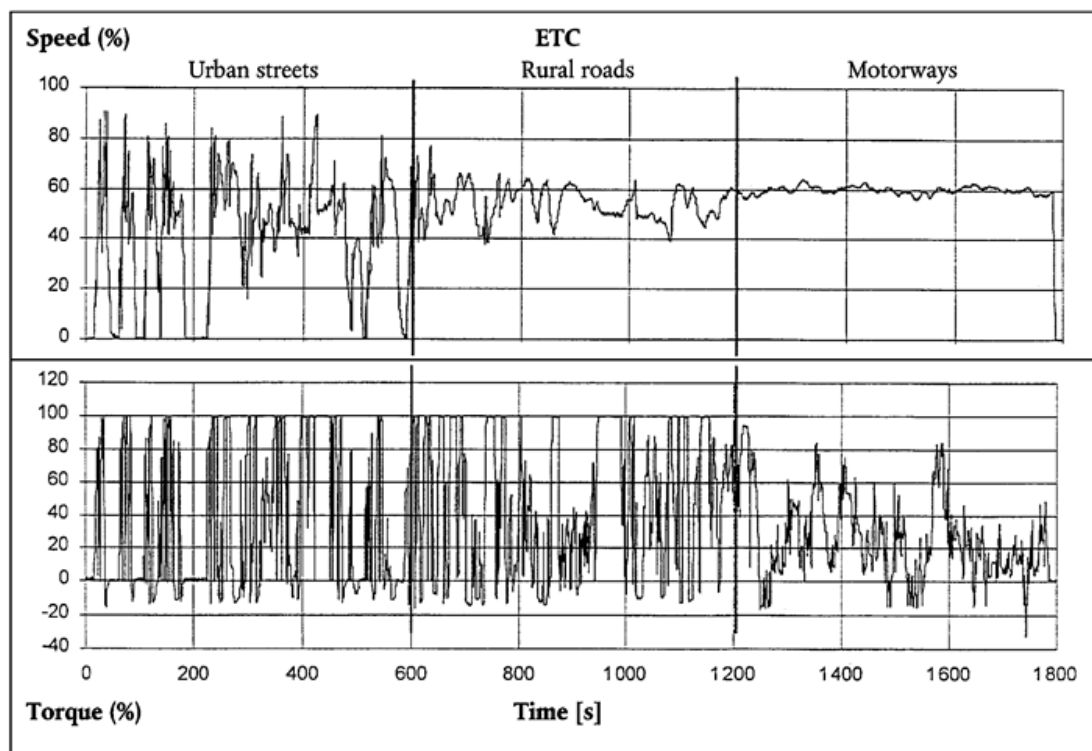

A sample of the diluted exhaust gas is transferred from the dilution tunnel DT of a full flow dilution system through the particulate sampling probe PSP and the particulate transfer tube PTT to the secondary dilution tunnel SDT, where it is diluted once more. The sample is then passed through the filter holder(s) FH that contain the particulate sampling filters. The dilution air flow rate is usually constant whereas the sample flow rate is controlled by the flow controller FC3. If electronic flow compensation EFC (see Figure 20) is used, the total diluted exhaust gas flow is used as command signal for FC3.

2.4.1. Components of Figures 21 and 22 PTT Particulate transfer tube (Figures 21, 22)

The particulate transfer tube must not exceed 1 020 mm in length, and must be minimised in length whenever possible. Where applicable (i.e. for partial flow dilution fractional sampling systems and for full flow dilution systems), the length of the sampling probes (SP, ISP, PSP, respectively, see Sections 2.2 and 2.3) shall be included.

The dimensions are valid for:

- the partial flow dilution fractional sampling type and the full flow single dilution system from the tip of the probe (SP, ISP, PSP, respectively) to the filter holder;
- the partial flow dilution total sampling type from the end of the dilution tunnel to the filter holder;
- the full flow double dilution system from the tip of the probe (PSP) to the secondary dilution tunnel.

The transfer tube:

- may be heated to no greater than 325 K (52 °C) wall temperature by direct heating or by dilution air pre-heating, provided the air temperature does not exceed 325 K (52 °C) prior to the introduction of the exhaust in the dilution tunnel;
- may be insulated.

SDT Secondary dilution tunnel (Figure 22)

The secondary dilution tunnel should have a minimum diameter of 75 mm, and should be of sufficient length so as to provide a residence time of at least 0,25 seconds for the doubly-diluted sample. The primary filter holder FH shall be located within 300 mm of the exit of the SDT.

The secondary dilution tunnel:

- may be heated to no greater than 325 K (52 °C) wall temperature by direct heating or by dilution air pre-heating, provided the air temperature does not exceed 325 K (52 °C) prior to the introduction of the exhaust in the dilution tunnel;
- may be insulated.

FH Filter holder(s) (Figures 21, 22)

For primary and back-up filters one filter housing or separate filter housings may be used. The requirements of Annex III, Appendix 4, Section 4.1.3 shall be met.

The filter holder(s):

- may be heated to no greater than 325 K (52 °C) wall temperature by direct heating or by dilution air pre-heating, provided the air temperature does not exceed 325 K (52 °C) prior to the introduction of the exhaust in the dilution tunnel;
- may be insulated.

P Sampling pump (Figures 21, 22)

The particulate sampling pump shall be located sufficiently distant from the tunnel so that the inlet gas temperature is maintained constant (± 3 K), if flow correction by FC3 is not used.

DP Dilution air pump (Figure 22)

The dilution air pump shall be located so that the secondary dilution air is supplied at a temperature of $298\text{ K} \pm 5\text{ K}$ ($25\text{ °C} \pm 5\text{ °C}$), if the dilution air is not preheated.

FC3 Flow controller (Figures 21, 22)

A flow controller shall be used to compensate the particulate sample flow rate for temperature and backpressure variations in the sample path, if no other means are available. The flow controller is required if electronic flow compensation EFC (see Figure 20) is used.

FM3 Flow measurement device (Figures 21, 22)

The gas meter or flow instrumentation for the particulate sample flow shall be located sufficiently distant from the sampling pump P so that the inlet gas temperature remains constant ($\pm 3\text{ K}$), if flow correction by FC3 is not used.

FM4 Flow measurement device (Figure 22)

The gas meter or flow instrumentation for the dilution air flow shall be located so that the inlet gas temperature remains at $298\text{ K} \pm 5\text{ K}$ ($25\text{ °C} \pm 5\text{ °C}$).

BV Ball valve (optional)

The ball valve shall have an inside diameter not less than the inside diameter of the particulate transfer tube PTT, and a switching time of less than 0,5 seconds.

Note: If the ambient temperature in the vicinity of PSP, PTT, SDT, and FH is below 293 K (20 °C), precautions should be taken to avoid particle losses onto the cool wall of these parts. Therefore, heating and/or insulating these parts within the limits given in the respective descriptions is recommended. It is also recommended that the filter face temperature during sampling be not below 293 K (20 °C).

At high engine loads, the above parts may be cooled by a non-aggressive means such as a circulating fan, as long as the temperature of the cooling medium is not below 293 K (20 °C).

3. DETERMINATION OF SMOKE

3.1. Introduction

Sections 3.2 and 3.3 and Figures 23 and 24 contain detailed descriptions of the recommended opacimeter systems. Since various configurations can produce equivalent results, exact conformance with Figures 23 and 24 is not required. Additional components such as instruments, valves, solenoids, pumps, and switches may be used to provide additional information and coordinate the functions of the component systems. Other components which are not needed to maintain the accuracy on some systems, may be excluded if their exclusion is based upon good engineering judgement.

The principle of measurement is that light is transmitted through a specific length of the smoke to be measured and that proportion of the incident light which reaches a receiver is used to assess the light obscuration properties of the medium. The smoke measurement depends upon the design of the apparatus, and may be done in the exhaust pipe (full flow in-line opacimeter), at the end of the exhaust pipe (full flow end-of-line opacimeter) or by taking a sample from the exhaust pipe (partial flow opacimeter). For the determination of the light absorption coefficient from the opacity signal, the optical path length of the instrument shall be supplied by the instrument manufacturer.

3.2. Full flow opacimeter

Two general types of full flow opacimeters may be used (Figure 23). With the in-line opacimeter, the opacity of the full exhaust plume within the exhaust pipe is measured. With this type of opacimeter, the effective optical path length is a function of the opacimeter design.

With the end-of-line opacimeter, the opacity of the full exhaust plume is measured as it exits the exhaust pipe. With this type of opacimeter, the effective optical path length is a function of the exhaust pipe design and the distance between the end of the exhaust pipe and the opacimeter.

INFORMATION DOCUMENT No ...**IN ACCORDANCE WITH ANNEX I TO COUNCIL DIRECTIVE 70/156/EEC RELATING TO EC TYPE APPROVAL**

and referring to measures to be taken against the emission of gaseous and particulate pollutants from compression-ignition engines for use in vehicles, and the emission of gaseous pollutants from positive-ignition engines fuelled with natural gas or liquefied petroleum gas for use in vehicles

(Directive 2005/55/EC)

Vehicle type/parent engine/engine type ⁽¹⁾

0. GENERAL
- 0.1. Make (name of undertaking):
- 0.2. Type and commercial description (mention any variants):
- 0.3. Means and location of identification of type, if marked on the vehicle:
- 0.4. Category of vehicle (if applicable):
- 0.5. Category of engine: diesel/NG fuelled/LPG fuelled/ethanol fuelled ⁽¹⁾
- 0.6. Name and address of manufacturer:
- 0.7. Location of statutory plates and inscriptions and method of affixing:
- 0.8. In the case of components and separate technical units, location and method of affixing of the EC approval mark:
- 0.9. Address(es) of assembly plant(s):

Attachments

1. Essential characteristics of the (parent) engine and information concerning the conduct of test.
2. Essential characteristics of the engine family.
3. Essential characteristics of the engine types within the family.
4. Characteristics of the engine-related vehicle parts (if applicable).
5. Photographs and/or drawings of the parent engine type and, if applicable, of the engine compartment.
6. List further attachments if any.

Date, File

⁽¹⁾ Delete as appropriate.

3.2.1. Components of Figure 23

EP Exhaust Pipe

With an in-line opacimeter, there shall be no change in the exhaust pipe diameter within 3 exhaust pipe diameters before or after the measuring zone. If the diameter of the measuring zone is greater than the diameter of the exhaust pipe, a pipe gradually convergent before the measuring zone is recommended.

With an end-of-line opacimeter, the terminal 0,6 m of the exhaust pipe shall be of circular cross section and be free from elbows and bends. The end of the exhaust pipe shall be cut off squarely. The opacimeter shall be mounted centrally to the plume within 25 ± 5 mm of the end of the exhaust pipe.

OPL Optical Path Length

The length of the smoke obscured optical path between the opacimeter light source and the receiver, corrected as necessary for non-uniformity due to density gradients and fringe effect. The optical path length shall be submitted by the instrument manufacturer taking into account any measures against sooting (e.g. purge air). If the optical path length is not available, it shall be determined in accordance with ISO IDS 11614, Section 11.6.5. For the correct determination of the optical path length, a minimum exhaust gas velocity of 20 m/s is required.

LS Light source

The light source shall be an incandescent lamp with a colour temperature in the range of 2 800 to 3 250 K or a green light emitting diode (LED) with a spectral peak between 550 and 570 nm. The light source shall be protected against sooting by means that do not influence the optical path length beyond the manufacturers specifications.

LD Light detector

The detector shall be a photocell or a photodiode (with a filter, if necessary). In the case of an incandescent light source, the receiver shall have a peak spectral response similar to the photopic curve of the human eye (maximum response) in the range of 550 to 570 nm, to less than 4 % of that maximum response below 430 nm and above 680 nm. The light detector shall be protected against sooting by means that do not influence the optical path length beyond the manufacturers specifications.

CL Collimating lens

The light output shall be collimated to a beam with a maximum diameter of 30 mm. The rays of the light beam shall be parallel within a tolerance of 3° of the optical axis.

T1 Temperature sensor (optional)

The exhaust gas temperature may be monitored over the test.

3.3. Partial flow opacimeter

With the partial flow opacimeter (Figure 24), a representative exhaust sample is taken from the exhaust pipe and passed through a transfer line to the measuring chamber. With this type of opacimeter, the effective optical path length is a function of the opacimeter design. The response times referred to in the following section apply to the minimum flow rate of the opacimeter, as specified by the instrument manufacturer.

1. Intake system depression at rated engine speed and at 100 % load: kPa
2. Exhaust system back pressure at rated engine speed and at 100 % load: kPa
3. Volume of exhaust system: cm³
4. Power absorbed by the auxiliaries needed for operating the engine as specified in and under the operation conditions of Directive 80/1269/EEC, Annex I, Section 5.1.1.

Equipment	Power absorbed (kW) at various engine speeds						
	Idle	Low speed	High speed	Speed A ⁽¹⁾	Speed B ⁽¹⁾	Speed C ⁽¹⁾	Ref. speed ⁽²⁾
P(a) Auxiliaries needed for operating the engine (to be subtracted from measured engine power) See Appendix 1, Section 6.1.							

⁽¹⁾ ESC test.
⁽²⁾ ETC test only.

3.3.1. Components of Figure 24

EP Exhaust pipe

The exhaust pipe shall be a straight pipe of at least 6 pipe diameters upstream and 3 pipe diameters downstream of the tip of the probe.

SP Sampling probe

The sampling probe shall be an open tube facing upstream on or about the exhaust pipe centreline. The clearance with the wall of the tailpipe shall be at least 5 mm. The probe diameter shall ensure a representative sampling and a sufficient flow through the opacimeter.

TT Transfer tube

The transfer tube shall:

- Be as short as possible and ensure an exhaust gas temperature of 373 ± 30 K ($100 \text{ }^\circ\text{C} \pm 30 \text{ }^\circ\text{C}$) at the entrance to the measuring chamber.
- Have a wall temperature sufficiently above the dew point of the exhaust gas to prevent condensation.
- Be equal to the diameter of the sampling probe over the entire length.
- Have a response time of less than 0,05 s at minimum instrument flow, as determined according to Annex III, Appendix 4, Section 5.2.4.
- Have no significant effect on the smoke peak.

FM Flow measurement device

Flow instrumentation to detect the correct flow into the measuring chamber. The minimum and maximum flow rates shall be specified by the instrument manufacturer, and shall be such that the response time requirement of TT and the optical path length specifications are met. The flow measurement device may be close to the sampling pump, P, if used.

MC Measuring chamber

The measuring chamber shall have a non-reflective internal surface, or equivalent optical environment. The impingement of stray light on the detector due to internal reflections of diffusion effects shall be reduced to a minimum.

The pressure of the gas in the measuring chamber shall not differ from the atmospheric pressure by more than 0,75 kPa. Where this is not possible by design, the opacimeter reading shall be converted to atmospheric pressure.

The wall temperature of the measuring chamber shall be set to within ± 5 K between 343 K (70 °C) and 373 K (100 °C), but in any case sufficiently above the dew point of the exhaust gas to prevent condensation. The measuring chamber shall be equipped with appropriate devices for measuring the temperature.

OPL Optical path length

The length of the smoke obscured optical path between the opacimeter light source and the receiver, corrected as necessary for non-uniformity due to density gradients and fringe effect. The optical path length shall be submitted by the instrument manufacturer taking into account any measures against sooting (e.g. purge air). If the optical path length is not available, it shall be determined in accordance with ISO IDS 11614, Section 11.6.5.

LS Light source

The light source shall be an incandescent lamp with a colour temperature in the range of 2 800 to 3 250 K or a green light emitting diode (LED) with a spectral peak between 550 and 570 nm. The light source shall be protected against sooting by means that do not influence the optical path length beyond the manufacturers specifications.

LD Light detector

The detector shall be a photocell or a photodiode (with a filter, if necessary). In the case of an incandescent light source, the receiver shall have a peak spectral response similar to the photopic curve of the human eye (maximum response) in the range of 550 to 570 nm, to less than 4 % of that maximum response below 430 nm and above 680 nm. The light detector shall be protected against sooting by means that do not influence the optical path length beyond the manufacturers specifications.

CL Collimating lens

The light output shall be collimated to a beam with a maximum diameter of 30 mm. The rays of the light beam shall be parallel within a tolerance of 3° of the optical axis.

T1 Temperature sensor

To monitor the exhaust gas temperature at the entrance to the measuring chamber.

P Sampling pump (optional)

A sampling pump downstream of the measuring chamber may be used to transfer the sample gas through the measuring chamber.

ANNEX VI

- 3.2.4.6. Certification number according to Directive 1999/96/EC:
- 3.2.5. Inlet manifold injection
 - 3.2.5.1. Injection: single point/multipoint ⁽¹⁾
 - 3.2.5.2. Injection: continuous/simultaneously timed/sequentially timed ⁽¹⁾
 - 3.2.5.3. Injection equipment
 - 3.2.5.3.1. Make(s):
 - 3.2.5.3.2. Type(s):
 - 3.2.5.3.3. Adjustment possibilities:
 - 3.2.5.3.4. Certification number according to Directive 1999/96/EC:
 - 3.2.5.4. Supply pump (if applicable):
 - 3.2.5.4.1. Make(s):
 - 3.2.5.4.2. Type(s):
 - 3.2.5.4.3. Certification number according to Directive 1999/96/EC:
 - 3.2.5.5. Injector(s)
 - 3.2.5.5.1. Make(s):
 - 3.2.5.5.2. Type(s):
 - 3.2.5.5.3. Certification number according to Directive 1999/96/EC:
- 3.2.6. Direct injection
 - 3.2.6.1. Injection pump / pressure regulator ⁽¹⁾
 - 3.2.6.1.1. Make(s):
 - 3.2.6.1.2. Type(s):
 - 3.2.6.1.3. Injection timing:
 - 3.2.6.1.4. Certification number according to Directive 1999/96/EC:
 - 3.2.6.2. Injector(s)
 - 3.2.6.2.1. Make(s):
 - 3.2.6.2.2. Type(s):
 - 3.2.6.2.3. Opening pressure or characteristic diagram ⁽²⁾:
 - 3.2.6.2.4. Certification number according to Directive 1999/96/EC:
- 3.2.7. Electronic control unit (ECU)
 - 3.2.7.1. Make(s):
 - 3.2.7.2. Type(s):
 - 3.2.7.3. Adjustment possibilities:
- 3.2.8. NG fuel-specific equipment
 - 3.2.8.1. Variant 1
(only in the case of approvals of engines for several specific fuel compositions)

Appendix

to EC type-approval certificate No ... concerning the type approval of a vehicle/separate technical unit/component⁽²⁰⁾

- 3.1.2.3.1. Make(s):
- 3.1.2.3.2. Type(s):
- 3.1.2.3.3. Opening pressure kPa ⁽²⁾
or characteristic diagram ⁽¹⁾ ⁽²⁾:
- 3.1.2.4. Governor
- 3.1.2.4.1. Make(s):
- 3.1.2.4.2. Type(s):
- 3.1.2.4.3. Speed at which cut-off starts under full load: rpm
- 3.1.2.4.4. Maximum no-load speed: rpm
- 3.1.2.4.5. Idling speed: rpm
- 3.1.3. Cold start system
- 3.1.3.1. Make(s):
- 3.1.3.2. Type(s):
- 3.1.3.3. Description:
- 3.1.3.4. Auxiliary starting aid:
- 3.1.3.4.1. Make:
- 3.1.3.4.2. Type:
- 3.2. Gas fuelled engines ⁽³⁾
- 3.2.1. Fuel: Natural gas/LPG ⁽¹⁾
- 3.2.2. Pressure regulator(s) or vaporiser/pressure regulator(s) ⁽²⁾
- 3.2.2.1. Make(s):
- 3.2.2.2. Type(s):
- 3.2.2.3. Number of pressure reduction stages:
- 3.2.2.4. Pressure in final stage: min. kPa, max. kPa
- 3.2.2.5. Number of main adjustment points:
- 3.2.2.6. Number of idle adjustment points:
- 3.2.2.7. Certification number according to Directive 1999/96/EC ^(*):
- 3.2.3. Fuelling system: mixing unit / gas injection / liquid injection / direct injection ⁽¹⁾
- 3.2.3.1. Mixture strength regulation:
- 3.2.3.2. System description and/or diagram and drawings:
- 3.2.3.3. Certification number according to Directive 1999/96/EC:
- 3.2.4. Mixing unit
- 3.2.4.1. Number:
- 3.2.4.2. Make(s):
- 3.2.4.3. Type(s):
- 3.2.4.4. Location:
- 3.2.4.5. Adjustment possibilities:

ANNEX VII

EXAMPLE OF CALCULATION PROCEDURE

1. ESC TEST

1.1. Gaseous emissions

The measurement data for the calculation of the individual mode results are shown below. In this example, CO and NO_x are measured on a dry basis, HC on a wet basis. The HC concentration is given in propane equivalent (C3) and has to be multiplied by 3 to result in the C1 equivalent. The calculation procedure is identical for the other modes.

P(kW)	T _a (K)	H _a (g/kg)	G _{EXH} (kg)	G _{AIRW} (kg)	G _{FUEL} (kg)	HC(ppm)	CO(ppm)	NO _x (ppm)
82,9	294,8	7,81	563,38	545,29	18,09	6,3	41,2	495

Calculation of the dry to wet correction factor K_{W,r} (Annex III, Appendix 1, Section 4.2):

$$F_{FH} = \frac{1,969}{1 + \frac{18,09}{545,29}} = 1,9058$$

and

$$K_{W2} = \frac{1,608 \times 7,81}{1\,000 + (1,608 \times 7,81)} = 0,0124$$

$$K_{W,r} = \left(1 - 1,9058 \times \frac{18,09}{541,06}\right) - 0,0124 = 0,9239$$

Calculation of the wet concentrations:

$$CO = 41,2 \times 0,9239 = 38,1 \text{ ppm}$$

$$NO_x = 495 \times 0,9239 = 457 \text{ ppm}$$

Calculation of the NO_x humidity correction factor K_{H,D} (Annex III, Appendix 1, Section 4.3):

$$A = 0,309 \times 18,09/541,06 - 0,0266 = -0,0163$$

$$B = -0,209 \times 18,09/541,06 + 0,00954 = 0,0026$$

$$K_{H,D} = \frac{1}{1 - 0,0163 \times (7,81 - 10,71) + 0,0026 \times (294,8 - 298)} = 0,9625$$

Calculation of the emission mass flow rates (Annex III, Appendix 1, Section 4.4):

$$NO_x = 0,001587 \times 457 \times 0,9625 \times 563,38 = 393,27 \text{ g/h}$$

$$CO = 0,000966 \times 38,1 \times 563,38 = 20,735 \text{ g/h}$$

$$HC = 0,000479 \times 6,3 \times 3 \times 563,38 = 5,100 \text{ g/h}$$

Calculation of the specific emissions (Annex III, Appendix 1, Section 4.5):

The following example calculation is given for CO; the calculation procedure is identical for the other components.

The emission mass flow rates of the individual modes are multiplied by the respective weighting factors, as indicated in Annex III, Appendix 1, Section 2.7.1, and summed up to result in the mean emission mass flow rate over the cycle:

CO	=	(6,7 × 0,15) + (24,6 × 0,08) + (20,5 × 0,10) + (20,7 × 0,10) + (20,6 × 0,05) + (15,0 × 0,05) + (19,7 × 0,05) +
	=	30,91 g/h

The engine power of the individual modes is multiplied by the respective weighting factors, as indicated in Annex III, Appendix 1, Section 2.7.1, and summed up to result in the mean cycle power:

Status: This is the original version (as it was originally adopted).

$P(n)$	=	$(0,1 \times 0,15) + (96,8 \times 0,08) + (55,2 \times 0,10) + (82,9 \times 0,10) + (46,8 \times 0,05) + (70,1 \times 0,05) + (23,0 \times 0,05) + (1,1 \times 0,05)$
	=	60,006 kW

$$\bar{CO} = \frac{30,91}{60,006} = 0,0515 \text{ g/kWh}$$

Calculation of the specific NO_x emission of the random point (Annex III, Appendix 1, Section 4.6.1):

Assume the following values have been determined on the random point:

$$\begin{aligned} n_Z &= 1\,600 \text{ min}^{-1} \\ M_Z &= 495 \text{ Nm} \\ \text{NO}_{x \text{ mass},Z} &= 487,9 \text{ g/h (calculated according to the previous formulae)} \\ P(n)_Z &= 83 \text{ kW} \\ \text{NO}_{x,Z} &= 487,9/83 = 5,878 \text{ g/kWh} \end{aligned}$$

Determination of the emission value from the test cycle (Annex III, Appendix 1, Section 4.6.2):

Assume the values of the four enveloping modes on the ESC to be as follows:

n_{RT}	n_{SU}	E_R	E_S	E_T	E_U	M_R	M_S	M_T	M_U
1 368	1 785	5,943	5,565	5,889	4,973	515	460	681	610

$$E_{TU} = 5,889 + (4,973 - 5,889) \times (1\,600 - 1\,368) / (1\,785 - 1\,368) = 5,377 \text{ g/kWh}$$

$$E_{RS} = 5,943 + (5,565 - 5,943) \times (1\,600 - 1\,368) / (1\,785 - 1\,368) = 5,732 \text{ g/kWh}$$

$$M_{TU} = 681 + (601 - 681) \times (1\,600 - 1\,368) / (1\,785 - 1\,368) = 641,3 \text{ Nm}$$

$$M_{RS} = 515 + (460 - 515) \times (1\,600 - 1\,368) / (1\,785 - 1\,368) = 484,3 \text{ Nm}$$

$$E_Z = 5,732 + (5,377 - 5,732) \times (495 - 484,3) / (641,3 - 484,3) = 5,708 \text{ g/kWh}$$

Comparison of the NO_x emission values (Annex III, Appendix 1, Section 4.6.3):

$$\text{NO}_{x \text{ diff}} = 100 \times (5,878 - 5,708) / 5,708 = 2,98 \%$$

1.2. Particulate emissions

Particulate measurement is based on the principle of sampling the particulates over the complete cycle, but determining the sample and flow rates (M_{SAM} and G_{EDF}) during the individual modes. The calculation of G_{EDF} depends on the system used. In the following examples, a system with CO₂ measurement and carbon balance method and a system with flow measurement are used. When using a full flow dilution system, G_{EDF} is directly measured by the CVS equipment.

Calculation of G_{EDF} (Annex III, Appendix 1, Sections 5.2.3 and 5.2.4):

Assume the following measurement data of mode 4. The calculation procedure is identical for the other modes.

$G_{EXH}(\text{kg/h})$	$G_{FUEL}(\text{kg/h})$	$G_{DILW}(\text{kg/h})$	$G_{TOTW}(\text{kg/h})$	CO _{2D} (%)	CO _{2A} (%)
334,02	10,76	5,4435	6,0	0,657	0,04

(a) carbon balance method

$$G_{EDFW} = \frac{206,5 \times 10,76}{0,657 - 0,040} = 3\,601,2 \text{ kg/h}$$

(b) flow measurement method

Status: This is the original version (as it was originally adopted).

$$q = \frac{6,0}{6,0-5,4435} = 10,78$$

$$G_{EDFW} = 334,02 \times 10,78 = 3\,600,7 \text{ kg/h}$$

Calculation of the mass flow rate (Annex III, Appendix 1, Section 5.4):

The G_{EDFW} flow rates of the individual modes are multiplied by the respective weighting factors, as indicated in Annex III, Appendix 1, Section 2.7.1, and summed up to result in the mean G_{EDF} over the cycle. The total sample rate M_{SAM} is summed up from the sample rates of the individual modes.

\bar{G}_{EDFW}	=	$(3\,567 \times 0,15) + (3\,592 \times 0,08) + (3\,611 \times 0,10) + (3\,600 \times 0,10) + (3\,618 \times 0,05) + (3\,600 \times 0,05) + (3\,640 \times 0,05) +$
	=	3 604,6 kg/h
M_{SAM}	=	$0,226 + 0,122 + 0,151 +$ $0,152 + 0,076 + 0,076 +$ $0,076 + 0,136 + 0,151 +$ $0,121 + 0,076 + 0,076 +$ 0,075
	=	1,515 kg

Assume the particulate mass on the filters to be 2,5 mg, then

$$PT_{mass} = \frac{2,5}{1,515} \times \frac{360,4}{1\,000} = 5,948 \text{ g/h}$$

Background correction (optional)

Assume one background measurement with the following values. The calculation of the dilution factor DF is identical to Section 3.1 of this Annex and not shown here.

$$M_d = 0,1 \text{ mg}; M_{DIL} = 1,5 \text{ kg}$$

Sum of DF	=	$[(1-1/119,15) \times 0,15] + [(1-1/8,89) \times 0,08] + [(1-1/14,75) \times 0,10] + [(1-1/10,10) \times 0,10] + [(1-1/18,02) \times 0,05] + [(1-1/12,33) \times 0,05] + [(1-1/32,18) \times 0,05]$
	=	0,923

$$PT_{mass} = \frac{2,5}{1,515} \cdot \left(\frac{0,1}{1,5} \times 0,923 \right) \times \frac{3\,604,6}{1\,000} = 5,726 \text{ g/h}$$

Calculation of the specific emission (Annex III, Appendix 1, Section 5.5):

$P(n)$	=	$(0,1 \times 0,15) + (96,8 \times 0,08) + (55,2 \times 0,10) + (82,9 \times 0,10) + (46,8 \times 0,05) + (70,1 \times 0,05) + (23,0 \times 0,05) +$
	=	60,006 kW

$$\bar{PT} = \frac{5,948}{60,006} = 0,099 \text{ g/kWh}$$

$$\bar{PT} = (5,726/60,006) = 0,095 \text{ g/kWh, if background corrected}$$

Calculation of the specific weighting factor (Annex III, Appendix 1, Section 5.6):

Assume the values calculated for mode 4 above, then

$$WF_{E,i} = (0,152 \times 3\,604,6/1,515 \times 3\,600,7) = 0,1004$$

This value is within the required value of $0,10 \pm 0,003$.

2. ELR TEST

Since Bessel filtering is a completely new averaging procedure in European exhaust legislation, an explanation of the Bessel filter, an example of the design of a Bessel algorithm, and an example of the calculation of the final smoke value is given below. The constants of the Bessel algorithm only depend on the design of the opacimeter and the sampling rate of the data acquisition system. It is recommended that the opacimeter manufacturer provide the final Bessel filter constants for different sampling rates and that the customer use these constants for designing the Bessel algorithm and for calculating the smoke values.

2.1. General remarks on the Bessel filter

Due to high frequency distortions, the raw opacity signal usually shows a highly scattered trace. To remove these high frequency distortions a Bessel filter is required for the ELR-test. The Bessel filter itself is a recursive, second-order low-pass filter which guarantees the fastest signal rise without overshoot.

Assuming a real time raw exhaust plume in the exhaust tube, each opacimeter shows a delayed and differently measured opacity trace. The delay and the magnitude of the measured opacity trace is primarily dependent on the geometry of the measuring chamber of the opacimeter, including the exhaust sample lines, and on the time needed for processing the signal in the electronics of the opacimeter. The values that characterise these two effects are called the physical and the electrical response time which represent an individual filter for each type of opacimeter.

The goal of applying a Bessel filter is to guarantee a uniform overall filter characteristic of the whole opacimeter system, consisting of:

- physical response time of the opacimeter (t_p),
- electrical response time of the opacimeter (t_e),
- filter response time of the applied Bessel filter (t_f).

The resulting overall response time of the system t_{Aver} is given by:

$$t_{Aver} = \sqrt{t_2^p + t_2^e + t_2^f}$$

and must be equal for all kinds of opacimeters in order to give the same smoke value. Therefore, a Bessel filter has to be created in such a way, that the filter response time (t_f) together with the physical (t_p) and electrical response time (t_e) of the individual opacimeter must result in the required overall response time (t_{Aver}). Since t_p and t_e are given values for each individual opacimeter, and t_{Aver} is defined to be 1,0 s in this Directive, t_f can be calculated as follows:

$$t_f = \sqrt{t_2^{Aver} + t_2^p + t_2^e}$$

By definition, the filter response time t_f is the rise time of a filtered output signal between 10 % and 90 % on a step input signal. Therefore the cut-off frequency of the Bessel filter has to be iterated in such a way, that the response time of the Bessel filter fits into the required rise time.

Status: This is the original version (as it was originally adopted).

1. **Common parameters**
 - 1.1. Combustion cycle:
 - 1.2. Cooling medium:
 - 1.3. Number of cylinders ⁽¹⁾:
 - 1.4. Individual cylinder displacement:
 - 1.5. Method of air aspiration:
 - 1.6. Combustion chamber type/design:
 - 1.7. Valve and porting — configuration, size and number:
 - 1.8. Fuel system:
 - 1.9. Ignition system (gas engines):
 - 1.10. Miscellaneous features:
 - charge cooling system ⁽¹⁾:
 - exhaust gas recirculation ⁽¹⁾:
 - water injection/emulsion ⁽¹⁾:
 - air injection ⁽¹⁾:
 - 1.11. Exhaust aftertreatment ⁽¹⁾:
- Proof of identical (or lowest for the parent engine) ratio: system capacity/fuel delivery per stroke, pursuant to diagram number(s):

2. **Engine family listing**
 - 2.1. Name of diesel engine family:
 - 2.1.1. Specification of engines within this family:

					Parent engine
Engine type					
No of cylinders					
Rated speed (rpm)					
Fuel delivery per stroke (mm ³)					
Rated net power (kW)					
Maximum torque speed (rpm)					
Fuel delivery per stroke (mm ³)					
Maximum torque (Nm)					
Low idle speed (rpm)					
Cylinder displacement (in % of parent engine)					100

⁽¹⁾ If not applicable, mark n.a.

In Figure a, the traces of a step input signal and Bessel filtered output signal as well as the response time of the Bessel filter (t_F) are shown.

Designing the final Bessel filter algorithm is a multi step process which requires several iteration cycles. The scheme of the iteration procedure is presented below.

2.2. Name of gas engine family:

2.2.1. Specification of engines within this family:

	Parent engine				
Engine type					
No of cylinders					
Rated speed (rpm)					
Fuel delivery per stroke (mm ³)					
Rated net power (kW)					
Maximum torque speed (rpm)					
Fuel delivery per stroke (mm ³)					
Maximum torque (Nm)					
Low idle speed (rpm)					
Cylinder displacement (in % of parent engine)					100
Spark timing					
EGR flow					
Air pump yes/no					
Air pump actual flow					

2.2. Calculation of the Bessel algorithm

In this example a Bessel algorithm is designed in several steps according to the above iteration procedure which is based upon Annex III, Appendix 1, Section 6.1.

For the opacimeter and the data acquisition system, the following characteristics are assumed:

- physical response time t_p 0,15 s
- electrical response time t_e 0,05 s
- overall response time t_{Aver} 1,00 s (by definition in this Directive)
- sampling rate 150 Hz

Step 1 Required Bessel filter response time t_F :

$$t_F = \sqrt{1^2 - (0,15^2 + 0,05^2)} = 0,987421 \text{ s}$$

Step 2 Estimation of cut-off frequency and calculation of Bessel constants E, K for first iteration:

$$f_c = \frac{3,1415}{10 \times 0,987421} = 0,318152 \text{ Hz}$$

$$\Delta t = 1/150 = 0,006667 \text{ s}$$

Status: This is the original version (as it was originally adopted).

$$\begin{aligned}\Omega &= \frac{1}{\tan[3,1415 \times 0,006667 \times 0,318152]} = 150,07664 \\ E &= \frac{1}{1 + 150,076644 \times \sqrt{3 \times 0,618034 + 0,618034 + 150,076644^2}} = 7,07948 \times 10^{-5} \\ K &= 2 \times 7,07948 \times 10^{-5} \times (0,618034 \times 150,076644^2 - 1) - 1 = 0,970783\end{aligned}$$

This gives the Bessel algorithm:

$$Y_i = Y_{i-1} + 7,07948 E - 5 \times (S_i + 2 \times S_{i-1} + S_{i-2} - 4 \times Y_{i-2}) + 0,970783 \times (Y_{i-1} - Y_{i-2})$$

where S_i represents the values of the step input signal (either '0' or '1') and Y_i represents the filtered values of the output signal.

Step 3 Application of Bessel filter on step input:

The Bessel filter response time t_F is defined as the rise time of the filtered output signal between 10 % and 90 % on a step input signal. For determining the times of 10 % (t_{10}) and 90 % (t_{90}) of the output signal, a Bessel filter has to be applied to a step input using the above values of f_c , E and K .

The index numbers, the time and the values of a step input signal and the resulting values of the filtered output signal for the first and the second iteration are shown in Table B. The points adjacent to t_{10} and t_{90} are marked in bold numbers.

In Table B, first iteration, the 10 % value occurs between index number 30 and 31 and the 90 % value occurs between index number 191 and 192. For the calculation of $t_{F,iter}$ the exact t_{10} and t_{90} values are determined by linear interpolation between the adjacent measuring points, as follows:

$$t_{10} = t_{lower} + \Delta t \times (0,1 - out_{lower}) / (out_{upper} - out_{lower})$$

$$t_{90} = t_{lower} + \Delta t \times (0,9 - out_{lower}) / (out_{upper} - out_{lower})$$

where out_{upper} and out_{lower} , respectively, are the adjacent points of the Bessel filtered output signal, and t_{lower} is the time of the adjacent time point, as indicated in Table B.

$$t_{10} = 0,200000 + 0,006667 \times (0,1 - 0,099208) / (0,104794 - 0,099208) = 0,200945 \text{ s}$$

$$t_{90} = 0,273333 + 0,006667 \times (0,9 - 0,899147) / (0,901168 - 0,899147) = 1,276147 \text{ s}$$

Step 4 Filter response time of first iteration cycle:

$$t_{F,iter} = 1,276147 - 0,200945 = 1,075202 \text{ s}$$

Step 5 Deviation between required and obtained filter response time of first iteration cycle:

$$\Delta = (1,075202 - 0,987421) / 0,987421 = 0,081641$$

Step 6 Checking the iteration criteria:

$|\Delta| \leq 0,01$ is required. Since $0,081641 > 0,01$, the iteration criteria is not met and a further iteration cycle has to be started. For this iteration cycle, a new cut-off frequency is calculated from f_c and Δ as follows:

$$f_{c,new} = 0,318152 \times (1 + 0,081641) = 0,344126 \text{ Hz}$$

This new cut-off frequency is used in the second iteration cycle, starting at step 2 again. The iteration has to be repeated until the iteration criteria is met. The resulting values of the first and second iteration are summarised in Table A.

TABLE A

Values of the first and second iteration

Parameter	1. Iteration	2. Iteration
-----------	--------------	--------------

Status: This is the original version (as it was originally adopted).

f_c	(Hz)	0,318152	0,344126
E	(-)	7,07948 E-5	8,272777 E-5
K	(-)	0,970783	0,96841
t_{10}	(s)	0,200945	0,185523
t_{90}	(s)	1,276147	1,179562
$t_{F,iter}$	(s)	1,075202	0,994039
Δ	(-)	0,081641	0,006657
$f_{c,new}$	(Hz)	0,344126	0,346417

Step 7 Final Bessel algorithm:

As soon as the iteration criteria has been met, the final Bessel filter constants and the final Bessel algorithm are calculated according to step 2. In this example, the iteration criteria has been met after the second iteration ($\Delta = 0,006657 \leq 0,01$). The final algorithm is then used for determining the averaged smoke values (see next Section 2.3).

$$Y_i = Y_{i,1} + 8,272777 \times 10^{-6} \times (S_i + 2 \times S_{i-1} + S_{i-2} - 4 \times Y_{i,2}) + 0,968410 \times (Y_{i,1} - Y_{i,2})$$

TABLE B

Values of step input signal and Bessel filtered output signal for the first and second iteration cycle

Index i[-]	Time[s]	Step input signal S_i [-]	Filtered output signal Y_i [-]	
			1. Iteration	2. Iteration
- 2	- 0,013333	0	0,0	0,0
- 1	- 0,006667	0	0,0	0,0
0	0,0	1	0,000071	0,000083
1	0,006667	1	0,000352	0,000411
2	0,013333	1	0,000908	0,00106
3	0,02	1	0,001731	0,002019
4	0,026667	1	0,002813	0,003278
5	0,033333	1	0,004145	0,004828
~	~	~	~	~
24	0,16	1	0,067877	0,077876
25	0,166667	1	0,072816	0,083476
26	0,173333	1	0,077874	0,089205
27	0,18	1	0,083047	0,095056
28	0,186667	1	0,088331	0,101024
29	0,193333	1	0,093719	0,107102

Status: This is the original version (as it was originally adopted).

30	0,2	1	0,099208	0,113286
31	0,206667	1	0,104794	0,11957
32	0,213333	1	0,110471	0,125949
33	0,22	1	0,116236	0,132418
34	0,226667	1	0,122085	0,138972
35	0,233333	1	0,128013	0,145605
36	0,24	1	0,134016	0,152314
37	0,246667	1	0,140091	0,159094
~	~	~	~	~
175	1,166667	1	0,862416	0,895701
176	1,173333	1	0,864968	0,897941
177	1,18	1	0,867484	0,900145
178	1,186667	1	0,869964	0,902312
179	1,193333	1	0,87241	0,904445
180	1,2	1	0,874821	0,906542
181	1,206667	1	0,877197	0,908605
182	1,213333	1	0,87954	0,910633
183	1,22	1	0,881849	0,912628
184	1,226667	1	0,884125	0,914589
185	1,233333	1	0,886367	0,916517
186	1,24	1	0,888577	0,918412
187	1,246667	1	0,890755	0,920276
188	1,253333	1	0,8929	0,922107
189	1,26	1	0,895014	0,923907
190	1,266667	1	0,897096	0,925676
191	1,273333	1	0,899147	0,927414
192	1,28	1	0,901168	0,929121
193	1,286667	1	0,903158	0,930799
194	1,293333	1	0,905117	0,932448
195	1,3	1	0,907047	0,934067
~	~	~	~	~

2.3. Calculation of the smoke values

In the scheme below the general procedure of determining the final smoke value is presented.

Status: This is the original version (as it was originally adopted).

ESSENTIAL CHARACTERISTICS OF THE (PARENT) ENGINE AND INFORMATION CONCERNING THE CONDUCT OF TEST ⁽¹⁾

1. **Description of engine**
 - 1.1. Manufacturer:
 - 1.2. Manufacturer's engine code:
 - 1.3. Cycle: four stroke / two stroke ⁽²⁾:
 - 1.4. Number and arrangement of cylinders:
 - 1.4.1. Bore: mm
 - 1.4.2. Stroke: mm
 - 1.4.3. Firing order:
 - 1.5. Engine capacity: cm³
 - 1.6. Volumetric compression ratio ⁽³⁾:
 - 1.7. Drawing(s) of combustion chamber and piston crown:
 - 1.8. Minimum cross-sectional area of inlet and outlet ports: cm²
 - 1.9. Idling speed: min⁻¹
 - 1.10. Maximum net power: kW at min⁻¹
 - 1.11. Maximum permitted engine speed: min⁻¹
 - 1.12. Maximum net torque: Nm at min⁻¹
 - 1.13. Combustion system: compression ignition/positive ignition ⁽²⁾
 - 1.14. Fuel: Diesel/LPG/NG-H/NG-L/NG-HL/ethanol ⁽²⁾
 - 1.15. Cooling system
 - 1.15.1. Liquid
 - 1.15.1.1. Nature of liquid:
 - 1.15.1.2. Circulating pump(s): yes/no ⁽²⁾
 - 1.15.1.3. Characteristics or make(s) and type(s) (if applicable):
 - 1.15.1.4. Drive ratio(s) (if applicable):
 - 1.15.2. Air
 - 1.15.2.1. Blower: yes/no ⁽²⁾
 - 1.15.2.2. Characteristics or make(s) and type(s) (if applicable):
 - 1.15.2.3. Drive ratio(s) (if applicable):
 - 1.16. Temperature permitted by the manufacturer
 - 1.16.1. Liquid cooling: Maximum temperature at outlet: K
 - 1.16.2. Air cooling: reference point:
 - Maximum temperature at reference point: K

⁽¹⁾ In the case of non-conventional engines and systems, particulars equivalent to those referred to here shall be supplied by the manufacturer.

⁽²⁾ Strike out what does not apply.

⁽³⁾ Specify the tolerance.

In Figure b, the traces of the measured raw opacity signal, and of the unfiltered and filtered light absorption coefficients (k-value) of the first load step of an ELR-Test are shown, and the maximum value $Y_{\max 1, A}$ (peak) of the filtered k trace is indicated. Correspondingly, Table C contains the numerical values of index i, time (sampling rate of 150 Hz), raw opacity, unfiltered k and filtered k. Filtering was conducted using the constants of the Bessel algorithm designed in Section 2.2 of this Annex. Due to the large amount of data, only those sections of the smoke trace around the beginning and the peak are tabled.

- 1.16.3. Maximum temperature of the air at the outlet of the intake intercooler (if applicable):
..... K
- 1.16.4. Maximum exhaust temperature at the point in the exhaust pipe(s) adjacent to the outer flange(s) of the exhaust manifold(s) or turbocharger(s):
..... K
- 1.16.5. Fuel temperature: min. K, max. K
for diesel engines at injection pump inlet, for gas fuelled engines at pressure regulator final stage
- 1.16.6. Fuel pressure: min. kPa, max. kPa
at pressure regulator final stage, NG fuelled gas engines only
- 1.16.7. Lubricant temperature: min. K, max. K
- 1.17. *Pressure charger: yes/no* ⁽¹⁾
- 1.17.1. Make:
- 1.17.2. Type:
- 1.17.3. Description of the system (e.g. max. charge pressure, wastegate, if applicable):
.....
- 1.17.4. Intercooler: yes/no ⁽¹⁾
- 1.18. *Intake system*
Maximum allowable intake depression at rated engine speed and at 100 % load as specified in and under the operating conditions of Council Directive 80/1269/EEC of 16 December 1980 on the approximation of the laws of the Member States relating to the engine power of motor vehicles ⁽²⁾:
..... kPa
- 1.19. *Exhaust system*
Maximum allowable exhaust back pressure at rated engine speed and at 100 % load as specified in and under the operating conditions of Directive 80/1269/EEC:
..... kPa
Exhaust system volume: dm³
2. **Measures taken against air pollution**
- 2.1. Device for recycling crankcase gases (description and drawings):
- 2.2. Additional anti-pollution devices (if any, and if not covered by another heading)
- 2.2.1. Catalytic converter: yes/no ⁽¹⁾
- 2.2.1.1. Make(s):
- 2.2.1.2. Type(s):
- 2.2.1.3. Number of catalytic converters and elements:
- 2.2.1.4. Dimensions, shape and volume of the catalytic converter(s):
- 2.2.1.5. Type of catalytic action:
- 2.2.1.6. Total charge of precious metals:

⁽¹⁾ Not applicable where not applicable.

Status: This is the original version (as it was originally adopted).

The peak value ($i = 272$) is calculated assuming the following data of Table C. All other individual smoke values are calculated in the same way. For starting the algorithm, S_{-1} , S_{-2} , Y_{-1} and Y_{-2} are set to zero.

L_A (m)	0,43
Index i	272
N (%)	16,783
S_{271} (m^{-1})	0,427392
S_{270} (m^{-1})	0,427532
Y_{271} (m^{-1})	0,542383
Y_{270} (m^{-1})	0,542337

Calculation of the k -value (Annex III, Appendix 1, Section 6.3.1):

$$k = -(1/0,430) \times \ln(1-(16,783/100)) = 0,427252 \text{ m}^{-1}$$

This value corresponds to S_{272} in the following equation.

Calculation of Bessel averaged smoke (Annex III, Appendix 1, Section 6.3.2):

In the following equation, the Bessel constants of the previous Section 2.2 are used. The actual unfiltered k -value, as calculated above, corresponds to S_{272} (S_i). S_{271} (S_{i-1}) and S_{270} (S_{i-2}) are the two preceding unfiltered k -values, Y_{271} (Y_{i-1}) and Y_{270} (Y_{i-2}) are the two preceding filtered k -values.

Y_{272}	=	$0,542383 + 8,272777 \times 10^{-5} \times (0,427252 + 2 \times 0,427392 + 0,427532 - 4 \times 0,427392 \times 0,427532)$
	=	0,542389 m^{-1}

This value corresponds to $Y_{\max 1,A}$ in the following equation.

Calculation of the final smoke value (Annex III, Appendix 1, Section 6.3.3):

From each smoke trace, the maximum filtered k -value is taken for the further calculation.

Assume the following values

Speed	Y_{\max} (m^{-1})		
	Cycle 1	Cycle 2	Cycle 3
A	0,5424	0,5435	0,5587
B	0,5596	0,54	0,5389
C	0,4912	0,5207	0,5177

$$SV_A = (0,5424 + 0,5435 + 0,5587) / 3 = 0,5482 \text{ m}^{-1}$$

$$SV_B = (0,5596 + 0,5400 + 0,5389) / 3 = 0,5462 \text{ m}^{-1}$$

$$SV_C = (0,4912 + 0,5207 + 0,5177) / 3 = 0,5099 \text{ m}^{-1}$$

$$SV = (0,43 \times 0,5482) + (0,56 \times 0,5462) + (0,01 \times 0,5099) = 0,5467 \text{ m}^{-1}$$

Cycle validation (Annex III, Appendix 1, Section 3.4)

Status: This is the original version (as it was originally adopted).

Before calculating SV, the cycle must be validated by calculating the relative standard deviations of the smoke of the three cycles for each speed.

Speed	Mean SV(m ⁻¹)	Absolute standard deviation(m ⁻¹)	Relative standard deviation(%)
A	0,5482	0,0091	1,7
B	0,5462	0,0116	2,1
C	0,5099	0,0162	3,2

In this example, the validation criteria of 15 % are met for each speed.

TABLE C

Values of opacity N, unfiltered and filtered k-value at beginning of load step

Index i[-]	Time[s]	Opacity N[%]	Unfiltered k-value[m ⁻¹]	Filtered k-value[m ⁻¹]
- 2	0,0	0,0	0,0	0,0
- 1	0,0	0,0	0,0	0,0
0	0,0	0,0	0,0	0,0
1	0,006667	0,02	0,000465	0,0
2	0,013333	0,02	0,000465	0,0
3	0,02	0,02	0,000465	0,0
4	0,026667	0,02	0,000465	0,000001
5	0,033333	0,02	0,000465	0,000002
6	0,04	0,02	0,000465	0,000002
7	0,046667	0,02	0,000465	0,000003
8	0,053333	0,02	0,000465	0,000004
9	0,06	0,02	0,000465	0,000005
10	0,066667	0,02	0,000465	0,000006
11	0,073333	0,02	0,000465	0,000008
12	0,08	0,02	0,000465	0,000009
13	0,086667	0,02	0,000465	0,000011
14	0,093333	0,02	0,000465	0,000012
15	0,1	0,192	0,004469	0,000014
16	0,106667	0,212	0,004935	0,000018
17	0,113333	0,212	0,004935	0,000022
18	0,12	0,212	0,004935	0,000028
19	0,126667	0,343	0,00799	0,000036

Status: This is the original version (as it was originally adopted).

20	0,133333	0,566	0,0132	0,000047
21	0,14	0,889	0,020767	0,000061
22	0,146667	0,929	0,021706	0,000082
23	0,153333	0,929	0,021706	0,000109
24	0,16	1,263	0,029559	0,000143
25	0,166667	1,455	0,034086	0,000185
26	0,173333	1,697	0,039804	0,000237
27	0,18	2,03	0,047695	0,000301
28	0,186667	2,081	0,048906	0,000378
29	0,193333	2,081	0,048906	0,000469
30	0,2	2,424	0,057067	0,000573
31	0,206667	2,475	0,058282	0,000693
32	0,213333	2,475	0,058282	0,000827
33	0,22	2,808	0,066237	0,000977
34	0,226667	3,01	0,071075	0,001144
35	0,233333	3,253	0,076909	0,001328
36	0,24	3,606	0,08541	0,001533
37	0,246667	3,96	0,093966	0,001758
38	0,253333	4,455	0,105983	0,002007
39	0,26	4,818	0,114836	0,002283
40	0,266667	5,02	0,119776	0,002587

VALUES OF OPACITY N, UNFILTERED AND FILTERED K-VALUE
AROUND $Y_{MAX1,A}$ (= PEAK VALUE, INDICATED IN BOLD NUMBER)

Index i[-]	Time[s]	Opacity N[%]	Unfiltered k-value[m ⁻¹]	Filtered k-value[m ⁻¹]
259	1,726667	17,182	0,438429	0,538856
260	1,733333	16,949	0,431896	0,539423
261	1,74	16,788	0,427392	0,539936
262	1,746667	16,798	0,427671	0,540396
263	1,753333	16,788	0,427392	0,540805
264	1,76	16,798	0,427671	0,541163
265	1,766667	16,798	0,427671	0,541473
266	1,773333	16,788	0,427392	0,541735
267	1,78	16,788	0,427392	0,541951

Status: This is the original version (as it was originally adopted).

268	1,786667	16,798	0,427671	0,542123
269	1,793333	16,798	0,427671	0,542251
270	1,8	16,793	0,427532	0,542337
271	1,806667	16,788	0,427392	0,542383
272	1,813333	16,783	0,427252	0,542389
273	1,82	16,78	0,427168	0,542357
274	1,826667	16,798	0,427671	0,542288
275	1,833333	16,778	0,427112	0,542183
276	1,84	16,808	0,427951	0,542043
277	1,846667	16,768	0,426833	0,54187
278	1,853333	16,01	0,40575	0,541662
279	1,86	16,01	0,40575	0,541418
280	1,866667	16,0	0,405473	0,541136
281	1,873333	16,01	0,40575	0,540819
282	1,88	16,0	0,405473	0,540466
283	1,886667	16,01	0,40575	0,54008
284	1,893333	16,394	0,416406	0,539663
285	1,9	16,394	0,416406	0,539216
286	1,906667	16,404	0,416685	0,538744
287	1,913333	16,394	0,416406	0,538245
288	1,92	16,394	0,416406	0,537722
289	1,926667	16,384	0,416128	0,537175
290	1,933333	16,01	0,40575	0,536604
291	1,94	16,01	0,40575	0,536009
292	1,946667	16,0	0,405473	0,535389
293	1,953333	16,01	0,40575	0,534745
294	1,96	16,212	0,411349	0,534079
295	1,966667	16,394	0,416406	0,533394
296	1,973333	16,394	0,416406	0,532691
297	1,98	16,192	0,410794	0,531971
298	1,986667	16,0	0,405473	0,531233
299	1,993333	16,0	0,405473	0,530477
300	2,0	16,0	0,405473	0,529704

3. ETC TEST

3.1. Gaseous emissions (diesel engine)

Assume the following test results for a PDP-CVS system

V_0 (m ³ /rev)	0,1776
N_p (rev)	23 073
p_B (kPa)	98,0
p_1 (kPa)	2,3
T (K)	322,5
H_a (g/kg)	12,8
$NO_{x\ conc}$ (ppm)	53,7
$NO_{x\ concd}$ (ppm)	0,4
CO_{conc} (ppm)	38,9
CO_{concd} (ppm)	1,0
HC_{conc} (ppm)	9,0
HC_{concd} (ppm)	3,02
$CO_{2,conc}$ (%)	0,723
W_{act} (kWh)	62,72

Calculation of the diluted exhaust gas flow (Annex III, Appendix 2, Section 4.1):

$$M_{TOTW} = 1,293 \times 0,1776 \times 23\,073 \times (98,0 - 2,3) \times 273 / (101,3 \times 322,5) = 4\,237,2 \text{ kg}$$

Calculation of the NO_x correction factor (Annex III, Appendix 2, Section 4.2):

$$K_{H, D} = \frac{1}{1 - 0,0182 \times (12,8 - 10,71)} = 1,039$$

Calculation of the background corrected concentrations (Annex III, Appendix 2, Section 4.3.1.1):

Assuming a diesel fuel of the composition $C_{11}H_{1,8}$

$$F_S = 100 \times \frac{1}{1 + \frac{1,8}{2} + [3,76 \times (1 + \frac{1,8}{4})]} = 13,6$$

$$DF = \frac{13,6}{0,723 + (9,00 + 38,9) \times 10^{-4}} = 18,69$$

$$NO_{x\ conc} = 53,7 - 0,4 \times (1 - (1/18,69)) = 53,3 \text{ ppm}$$

$$CO_{conc} = 38,9 - 1,0 \times (1 - (1/18,69)) = 37,9 \text{ ppm}$$

$$HC_{conc} = 9,00 - 3,02 \times (1 - (1/18,69)) = 6,14 \text{ ppm}$$

Calculation of the emissions mass flow (Annex III, Appendix 2, Section 4.3.1):

$$NO_{x\ mass} = 0,001587 \times 53,3 \times 1,039 \times 4\,237,2 = 372,391 \text{ g}$$

$$CO_{mass} = 0,000966 \times 37,9 \times 4\,237,2 = 155,129 \text{ g}$$

$$HC_{mass} = 0,000479 \times 6,14 \times 4\,237,2 = 12,462 \text{ g}$$

Calculation of the specific emissions (Annex III, Appendix 2, Section 4.4):

$$\dot{NO}_x = 372,391 / 62,72 = 5,94 \text{ g/kWh}$$

$$\dot{CO} = 155,129 / 62,72 = 2,47 \text{ g/kWh}$$

Status: This is the original version (as it was originally adopted).

$$\bar{HC} = 12,462/62,72 = 0,199 \text{ g/kWh}$$

3.2. Particulate emissions (diesel engine)

Assume the following test results for a PDP-CVS system with double dilution

M_{TOTW} (kg)	4 237,2
$M_{f,p}$ (mg)	3,03
$M_{f,b}$ (mg)	0,044
M_{TOT} (kg)	2,159
M_{SEC} (kg)	0,909
M_d (mg)	0,341
M_{DIL} (kg)	1,245
DF	18,69
W_{act} (kWh)	62,72

Calculation of the mass emission (Annex III, Appendix 2, Section 5.1):

$$M_f = 3,030 + 0,044 = 3,074 \text{ mg}$$

$$M_{SAM} = 2,159 - 0,909 = 1,250 \text{ kg}$$

$$PT_{mass} = \frac{3,074}{1,250} \times \frac{4\,237,2}{1\,000} = 10,42 \text{ g}$$

Calculation of the background corrected mass emission (Annex III, Appendix 2, Section 5.1):

$$PT_{mass} = \left[\frac{3,074}{1,250} - \left(\frac{0,341}{1,245} \times \left(1 + \frac{1}{18,69} \right) \right) \right] \times \frac{4\,237,2}{1\,000} = 9,32 \text{ g}$$

Calculation of the specific emission (Annex III, Appendix 2, Section 5.2):

$$\bar{PT} = 10,42/62,72 = 0,166 \text{ g/kWh}$$

$$\bar{PT} = 9,32/62,72 = 0,149 \text{ g/kWh, if background corrected}$$

3.3. Gaseous emissions (CNG engine)

Assume the following test results for a PDP-CVS system with double dilution

M_{TOTW} (kg)	4 237,2
H_a (g/kg)	12,8
NO_x conce (ppm)	17,2
NO_x concd (ppm)	0,4
CO_{conce} (ppm)	44,3
CO_{concd} (ppm)	1,0
HC_{conce} (ppm)	27,0
HC_{concd} (ppm)	3,02
CH_4 conce (ppm)	18,0
CH_4 concd (ppm)	1,7

CO _{2,conce} (%)	0,723
W _{act} (kWh)	62,72

Calculation of the NO_x correction factor (Annex III, Appendix 2, Section 4.2):

$$K_{H,G} = \frac{1}{1-0,0329 \times (12,8-10,71)} = 1,074$$

Calculation of the NMHC concentration (Annex III, Appendix 2, Section 4.3.1):

(a) GC method
 $NMHC_{conce} = 27,0-18,0 = 9,0 \text{ ppm}$

(b) NMC method

Assuming a methane efficiency of 0,04 and an ethane efficiency of 0,98 (see Annex III, Appendix 5, Section 1.8.4)

$$NMHC_{conce} = \frac{27,0 \times (1-0,04)-18,0}{0,98-0,04} = 8,4 \text{ ppm}$$

Calculation of the background corrected concentrations (Annex III, Appendix 2, Section 4.3.1.1):

Assuming a G₂₀ reference fuel (100 % methane) of the composition C₁H₄:

$$F_S = 100 \times \frac{1}{1 + \frac{1}{2} + (3,76 \times (1 + \frac{1}{4}))} = 9,5$$

$$DF = \frac{9,5}{0,723 + (27,0 + 44,3) \times 10^{-4}} = 13,01$$

For NMHC, the background concentration is the difference between HC_{concd} and CH₄concd

$$NO_{x \text{ conc}} = 17,2-0,4 \times (1-(1/13,01)) = 16,8 \text{ ppm}$$

$$CO_{conc} = 44,3-1,0 \times (1-(1/13,01)) = 43,4 \text{ ppm}$$

$$NMHC_{conc} = 8,4-1,32 \times (1-(1/13,01)) = 7,2 \text{ ppm}$$

$$CH_{4 \text{ conc}} = 18,0-1,7 \times (1-(1/13,01)) = 16,4 \text{ ppm}$$

Calculation of the emissions mass flow (Annex III, Appendix 2, Section 4.3.1):

$$NO_{x \text{ mass}} = 0,001587 \times 16,8 \times 1,074 \times 4 \text{ 237,2} = 121,330 \text{ g}$$

$$CO_{mass} = 0,000966 \times 43,4 \times 4 \text{ 237,2} = 177,642 \text{ g}$$

$$NMHC_{mass} = 0,000502 \times 7,2 \times 4 \text{ 237,2} = 15,315 \text{ g}$$

$$CH_{4 \text{ mass}} = 0,000554 \times 16,4 \times 4 \text{ 237,2} = 38,498 \text{ g}$$

Calculation of the specific emissions (Annex III, Appendix 2, Section 4.4):

$$\dot{NO}_x = 121,330/62,72 = 1,93 \text{ g/kWh}$$

$$\dot{CO} = 177,642/62,72 = 2,83 \text{ g/kWh}$$

$$NMHC = 15,315/62,72 = 0,244 \text{ g/kWh}$$

$$\dot{CH}_4 = 38,498/62,72 = 0,614 \text{ g/kWh}$$

4. λ-SHIFT FACTOR (S_λ)

4.1. Calculation of the λ-shift factor (S_λ)⁽²¹⁾

$$S_\lambda = \frac{2}{\left(1 - \frac{\text{inert \%}}{100}\right) \left(n + \frac{m}{4}\right) - O_2^* 100}$$

where:

S_λ = λ-shift factor;

inert % = % by volume of inert gases in the fuel (i.e. N₂, CO₂, He, etc.);

O₂^{*} = % by volume of original oxygen in the fuel;

n and m = refer to average C_nH_m representing the fuel hydrocarbons, i.e:

Status: This is the original version (as it was originally adopted).

$$n = \frac{1 \times \left[\frac{\text{CH}_4 \%}{100} \right] + 2 \times \left[\frac{\text{C}_2 \%}{100} \right] + 3 \times \left[\frac{\text{C}_3 \%}{100} \right] + 4 \times \left[\frac{\text{C}_4 \%}{100} \right] + 5 \times \left[\frac{\text{C}_5 \%}{100} \right] + \dots}{1 - \text{diluent} \%}$$

$$m = \frac{4 \times \left[\frac{\text{CH}_4 \%}{100} \right] + 4 \times \left[\frac{\text{C}_2 \text{H}_4 \%}{100} \right] + 6 \times \left[\frac{\text{C}_2 \text{H}_6 \%}{100} \right] + \dots + 8 \times \left[\frac{\text{C}_3 \text{H}_8 \%}{100} \right] + \dots}{1 - \text{diluent} \%}$$

where:

CH ₄	=	% by volume of methane in the fuel;
C ₂	=	% by volume of all C ₂ hydrocarbons (e.g. C ₂ H ₆ , C ₂ H ₄ , etc.) in the fuel;
C ₃	=	% by volume of all C ₃ hydrocarbons (e.g. C ₃ H ₈ , C ₃ H ₆ , etc.) in the fuel;
C ₄	=	% by volume of all C ₄ hydrocarbons (e.g. C ₄ H ₁₀ , C ₄ H ₈ , etc.) in the fuel;
C ₅	=	% by volume of all C ₅ hydrocarbons (e.g. C ₅ H ₁₂ , C ₅ H ₁₀ , etc.) in the fuel;
diluent	=	% by volume of dilution gases in the fuel (i.e. O ₂ [*] , N ₂ , CO ₂ , He etc.).

4.2. Examples for the calculation of the λ-shift factor S_λ

Example G₂₅: CH₄ = 86 %, N₂ = 14 % (by volume)

1:

$$n = \frac{1 \times \left[\frac{\text{CH}_4 \%}{100} \right] + 2 \times \left[\frac{\text{C}_2 \%}{100} \right] + \dots}{1 - \text{diluent} \%} = \frac{1 \times 0,86}{1 - \frac{14}{100}} = \frac{0,86}{0,86} = 1$$

$$m = \frac{4 \times \left[\frac{\text{CH}_4 \%}{100} \right] + 4 \times \left[\frac{\text{C}_2 \text{H}_4 \%}{100} \right] + \dots}{1 - \text{diluent} \%} = \frac{4 \times 0,86}{0,86} = 4$$

$$S_\lambda = \frac{2}{\left(1 - \frac{\text{inert} \%}{100}\right) \left(n + \frac{m}{4}\right) - \mathcal{O}_2^2 \cdot 100} = \frac{2}{\left(1 - \frac{14}{100}\right) \times \left(1 + \frac{4}{4}\right)} = 1,16$$

Example GR: CH₄ = 87 %, C₂H₆ = 13 % (by vol)

2:

$$n = \frac{1 \times \left[\frac{\text{CH}_4 \%}{100} \right] + 2 \times \left[\frac{\text{C}_2 \%}{100} \right] + \dots}{1 - \text{diluent} \%} = \frac{1 \times 0,87 + 2 \times 0,13}{1 - \frac{0}{100}} = \frac{1,13}{1} = 1,13$$

$$m = \frac{4 \times \left[\frac{\text{CH}_4 \%}{100} \right] + 4 \times \left[\frac{\text{C}_2 \text{H}_4 \%}{100} \right] + \dots}{1 - \text{diluent} \%} = \frac{4 \times 0,87 + 6 \times 0,13}{1} = 4,26$$

$$S_\lambda = \frac{2}{\left(1 - \frac{\text{inert} \%}{100}\right) \left(n + \frac{m}{4}\right) - \mathcal{O}_2^2 \cdot 100} = \frac{2}{\left(1 - \frac{0}{100}\right) \times \left(1,13 + \frac{4,26}{4}\right)} = 0,911$$

Example USA: CH₄ = 89 %, C₂H₆ = 4,5 %, C₃H₈ = 2,3 %, C₆H₁₄ = 0,2 %, O₂ = 0,6 %, N₂ = 4 %

3:

$$n = \frac{1 \times \left[\frac{\text{CH}_4 \%}{100} \right] + 2 \times \left[\frac{\text{C}_2 \%}{100} \right] + \dots}{1 - \text{diluent} \%} = \frac{1 \times 0,89 + 2 \times 0,045 + 3 \times 0,023 + 4 \times 0,002}{1 - \frac{(0,6 + 4)}{100}} = 1,11$$

$$m = \frac{4 \times \left[\frac{\text{CH}_4 \%}{100} \right] + 4 \times \left[\frac{\text{C}_2 \text{H}_4 \%}{100} \right] + 6 \times \left[\frac{\text{C}_2 \text{H}_6 \%}{100} \right] + \dots + 8 \times \left[\frac{\text{C}_3 \text{H}_8 \%}{100} \right] + \dots}{1 - \text{diluent} \%} = \frac{4 \times 0,89 + 4 \times 0,045 + 8 \times 0,023 + 14 \times 0,002}{1 - \frac{0,6 + 4}{100}} = 4,24$$

$$S_\lambda = \frac{2}{\left(1 - \frac{\text{inert} \%}{100}\right) \left(n + \frac{m}{4}\right) - \mathcal{O}_2^2 \cdot 100} = \frac{2}{\left(1 - \frac{4}{100}\right) \times \left(1,11 + \frac{4,24}{4}\right) - \frac{0,6}{100}} = 0,96$$

ANNEX VIII

SPECIFIC TECHNICAL REQUIREMENTS RELATING
TO ETHANOL-FUELLED DIESEL ENGINES

In the case of ethanol-fuelled diesel engines, the following specific modifications to the appropriate paragraphs, equations and factors will apply to the test procedures defined in Annex III to this Directive.

IN ANNEX III, APPENDIX 1:

4.2. Dry/wet correction

$$F_{FH} = \frac{1,877}{\left(\frac{1 + 1,877 \times G_{FUEL}}{G_{AIR} W} \right)}$$

4.3. NO_x correction for humidity and temperature

$$K_{H,D} = \frac{1}{1 + A \times (H_a - 10,71) + B \times (T_a - 298)}$$

with,

$$A = 0,181 G_{FUEL}/G_{AIR,D} - 0,0266$$

$$B = -0,123 G_{FUEL}/G_{AIR,D} + 0,00954$$

$$T_a = \text{temperature of the air, K}$$

$$H_a = \text{humidity of the intake air, g water per kg dry air}$$

4.4. Calculation of the emission mass flow rates

The emission mass flow rates (g/h) for each mode shall be calculated as follows, assuming the exhaust gas density to be 1,272 kg/m³ at 273 K (0 °C) and 101,3 kPa:

$$NO_{x \text{ mass}} = 0,001613 \times NO_{x \text{ conc}} \times K_{H,D} \times G_{EXH} W$$

$$CO_{x \text{ mass}} = 0,000982 \times CO_{\text{conc}} \times G_{EXH} W$$

$$HC_{\text{mass}} = 0,000809 \times HC_{\text{conc}} \times K_{H,D} \times G_{EXH} W$$

where

NO_{x conc}, CO_{conc}, HC_{conc}⁽²²⁾ are the average concentrations (ppm) in the raw exhaust gas, as determined in Section 4.1.

If, optionally, the gaseous emissions are determined with a full flow dilution system, the following formulae shall be applied:

$$NO_{x \text{ mass}} = 0,001587 \times NO_{x \text{ conc}} \times K_{H,D} \times G_{TOT} W$$

$$CO_{x \text{ mass}} = 0,000966 \times CO_{\text{conc}} \times G_{TOT} W$$

$$HC_{\text{mass}} = 0,000795 \times HC_{\text{conc}} \times G_{TOT} W$$

where

NO_{x conc}, CO_{conc}, HC_{conc}⁽²²⁾ are the average background corrected concentrations (ppm) of each mode in the diluted exhaust gas, as determined in Annex III, Appendix 2, Section 4.3.1.1.

IN ANNEX III, APPENDIX 2:

Sections 3.1, 3.4, 3.8.3 and 5 of Appendix 2 do not apply solely to diesel engines. They also apply to ethanol-fuelled diesel engines.

4.2. The conditions for the test should be arranged so that the air temperature and the humidity measured at the engine intake is set to standard conditions during the test run. The standard should be $6 \pm 0,5$ g water per kg dry air at a temperature interval of 298 ± 3 K. Within these limits no further NO_x correction should be made. The test is void if these conditions are not met.

4.3. Calculation of the emission mass flow

4.3.1 Systems with constant mass flow

For systems with heat exchanger, the mass of the pollutants (g/test) shall be determined from the following equations:

$$\text{NO}_{x \text{ mass}} = 0,001587 \times \text{NO}_{x \text{ conc}} \times K_{\text{H,D}} \times M_{\text{TOT W}} \text{ (ethanol fuelled engines)}$$

$$\text{CO}_{x \text{ mass}} = 0,000966 \times \text{CO}_{\text{conc}} \times M_{\text{TOT W}} \text{ (ethanol fuelled engines)}$$

$$\text{HC}_{\text{mass}} = 0,000794 \times \text{HC}_{\text{conc}} \times M_{\text{TOT W}} \text{ (ethanol fuelled engines)}$$

where,

$\text{NO}_{x \text{ conc}}$, CO_{conc} , $\text{HC}_{\text{conc}}^{(23)}$, $\text{NMHC}_{\text{conc}}$ = average background corrected concentrations over the cycle from integration (mandatory for NO_x and HC) or bag measurement, ppm;

M_{TOTW} = total mass of diluted exhaust gas over the cycle as determined in Section 4.1, kg.

4.3.1.1. Determination of the background corrected concentrations

The average background concentration of the gaseous pollutants in the dilution air shall be subtracted from measured concentrations to get the net concentrations of the pollutants. The average values of the background concentrations can be determined by the sample bag method or by continuous measurement with integration. The following formula shall be used.

$$\text{conc} = \text{conc}_e - \text{conc}_d \times \left(1 - \frac{1}{\text{DF}}\right)$$

where,

conc = concentration of the respective pollutant in the diluted exhaust gas, corrected by the amount of the respective pollutant contained in the dilution air, ppm;

conc_e = concentration of the respective pollutant measured in the diluted exhaust gas, ppm;

conc_d = concentration of the respective pollutant measured in the dilution air, ppm;

DF = dilution factor.

The dilution factor shall be calculated as follows:

$$\text{DF} = \frac{F_S}{\text{CO}_{2\text{conc}} + (\text{HC}_{\text{conc}} + \text{CO}_{\text{conc}}) \times 10^{-4}}$$

where,

$\text{CO}_{2\text{conc}}$ = concentration of CO_2 in the diluted exhaust gas, % vol

HC_{conc} = concentration of HC in the diluted exhaust gas, ppm C1

CO_{conc} = concentration of CO in the diluted exhaust gas, ppm

F_S = stoichiometric factor

Concentrations measured on dry basis shall be converted to a wet basis in accordance with Annex III, Appendix 1, Section 4.2.

The stoichiometric factor shall, for the general fuel composition $\text{CH}_\alpha\text{O}_\beta\text{N}_\gamma$, be calculated as follows:

$$F_S = 100 \times \frac{1}{1 + \frac{\alpha}{2} + 3,76 \times \left(1 + \frac{\alpha}{4} - \frac{\beta}{2}\right) + \frac{\gamma}{2}}$$

Alternatively, if the fuel composition is not known, the following stoichiometric factors may be used:

$$F_S (\text{Ethanol}) = 12,3$$

4.3.2. Systems with flow compensation

For systems without heat exchanger, the mass of the pollutants (g/test) shall be determined by calculating the instantaneous mass emissions and integrating the instantaneous values over the cycle. Also, the background correction shall be applied directly to the instantaneous concentration value. The following formulae shall be applied:

$$\text{NO}_x \text{ mass} = \sum_{i=1}^n (M_{\text{TOTW},i} \times \text{NO}_{x \text{ conc},i} \times 0,001587) - \left(M_{\text{TOTW}} \times \text{NO}_{x \text{ concd}} \times \left(1 - \frac{1}{\text{DF}}\right) \times 0,001587 \right)$$

$$\text{CO mass} = \sum_{i=1}^n (M_{\text{TOTW},i} \times \text{CO}_{\text{conc},i} \times 0,000966) - \left(M_{\text{TOTW}} \times \text{CO}_{\text{concd}} \times \left(1 - \frac{1}{\text{DF}}\right) \times 0,000966 \right)$$

$$\text{HC mass} = \sum_{i=1}^n (M_{\text{TOTW},i} \times \text{HC}_{\text{conc},i} \times 0,000749) - \left(M_{\text{TOTW}} \times \text{HC}_{\text{concd}} \times \left(1 - \frac{1}{\text{DF}}\right) \times 0,000749 \right)$$

where,

conc_e = concentration of the respective pollutant measured in the diluted exhaust gas, ppm;

conc_d = concentration of the respective pollutant measured in the dilution air, ppm;

$M_{\text{TOTW},i}$ = instantaneous mass of the diluted exhaust gas (see Section 4.1), kg;

M_{TOTW} = total mass of diluted exhaust gas over the cycle (see Section 4.1), kg;

DF = dilution factor as determined in Section 4.3.1.1.

4.4. Calculation of the specific emissions

The emissions (g/kWh) shall be calculated for all individual components in the following way:

$$\bar{\text{NO}}_x = \frac{\text{NO}_x \text{ mass}}{W_{\text{act}}}$$

$$\bar{\text{CO}} = \frac{\text{CO mass}}{W_{\text{act}}}$$

$$\bar{\text{HC}} = \frac{\text{HC mass}}{W_{\text{act}}}$$

where,

W_{act} = actual cycle work as determined in Section 3.9.2, kWh.

Status: This is the original version (as it was originally adopted).

ANNEX IX

TIME-LIMITS FOR THE TRANSPOSITION OF THE
REPEALED DIRECTIVES INTO NATIONAL LAWS
Referred to in Article 10

Part A		
Repealed Directives		
Directives	Official Journal	
Directive 88/77/EEC	L 36, 9.2.1988, p. 33.	
Directive 91/542/EEC	L 295, 25.10.1991, p. 1.	
Directive 96/1/EC	L 40, 17.2.1996, p. 1.	
Directive 1999/96/EC	L 44, 16.2.2000, p. 1.	
Directive 2001/27/EC	L 107, 18.4.2001, p. 10.	
Part B		
Time limits for transposition into national laws		
Directive	Time-limits for transposition	Date of application
Directive 88/77/EEC	1 July 1988	
Directive 91/542/EEC	1 January 1992	
Directive 96/1/EC	1 July 1996	
Directive 1999/96/EC	1 July 2000	
Directive 2001/27/EC	1 October 2001	1 October 2001

ANNEX X

CORRELATION TABLE
(Referred to in the second paragraph of Article 10)

Directive 88/77/EEC	Directive 91/542/EEC	Directive 1999/96/EC	Directive 2001/27/EC	This Directive
Article 1	—		—	Article 1
Article 2(1)	Article 2(1)	Article 2(1)	Article 2(1)	Article 2(4)
Article 2(2)	Article 2(2)	Article 2(2)	Article 2(2)	Article 2(1)
—	Article 2(3)	—	—	—
Article 2(3)	—	—	—	—
Article 2(4)	Article 2(4)	Article 2(3)	Article 2(3)	Article 2(2)
—	—	—	Article 2(4)	Article 2(3)
—	—	—	Article 2(5)	—

Status: This is the original version (as it was originally adopted).

—	—	Article 2(4)	—	Article 2(5)
—	—	Article 2(5)	—	Article 2(6)
—	—	Article 2(6)	—	Article 2(7)
—	—	Article 2(7)	—	Article 2(8)
—	—	Article 2(8)	—	Article 2(9)
Article 3	—	—	—	—
—	—	Article 5 and 6	—	Article 3
—	—	Article 4	—	Article 4
—	Article 3(1)	Article 3(1)	—	Article 6(1)
—	Article 3(1)(a)	Article 3(1)(a)	—	Article 6(2)
—	Article 3(1)(b)	Article 3(1)(b)	—	Article 6(3)
—	Article 3(2)	Article 3(2)	—	Article 6(4)
—	Article 3(3)	Article 3(3)	—	Article 6(5)
Article 4	—	—	—	Article 7
Article 6	Article 5 and 6	Article 7	—	Article 8
Article 5	Article 4	Article 8	Article 3	Article 9
—	—	—	—	Article 10
—	—	Article 9	Article 4	Article 11
Article 7	Article 7	Article 10	Article 5	Article 12
Annexes I to VII	—	—	—	Annexes I to VII
—	—	—	Annex VIII	Annex VIII
—	—	—	—	Annex IX
—	—	—	—	Annex X

- (1) OJ C 108, 30.4.2004, p. 32.
- (2) Opinion of the European Parliament of 9 March 2004 (OJ C 102 E, 28.4.2004, p. 272) and Council Decision of 19 September 2005.
- (3) OJ L 36, 9.2.1988, p. 33. Directive as last amended by the 2003 Act of Accession.
- (4) OJ L 42, 23.2.1970, p. 1. Directive as last amended by Commission Directive 2005/49/EC (OJ L 194, 26.7.2005, p. 12).
- (5) OJ L 295, 25.10.1991, p. 1.
- (6) OJ L 44, 16.2.2000, p. 1.
- (7) OJ L 107, 18.4.2001, p. 10.
- (8) OJ L 76, 6.4.1970, p. 1. Directive as last amended by Commission Directive 2003/76/EC (OJ L 206, 15.8.2003, p. 29).
- (9) OJ L 184, 17.7.1999, p. 23.
- (10) OJ L 76, 6.4.1970, p. 1. Directive as last amended by Commission Directive 2003/76/EC (OJ L 206, 15.8.2003, p. 29).
- (11) OJ L 375, 31.12.1980, p. 46. Directive as last amended by Commission Directive 1999/99/EC (OJ L 334, 28.12.1999, p. 32).
- (12) OJ L 42, 23.2.1970, p. 1. Directive as last amended by Commission Directive 2004/104/EC (OJ L 337, 13.11.2004, p. 13).
- (13) 1 = Germany, 2 = France, 3 = Italy, 4 = Netherlands, 5 = Sweden, 6 = Belgium, 7 = Hungary, 8 = Czech Republic, 9 = Spain, 11 = United Kingdom, 12 = Austria, 13 = Luxembourg, 17 = Finland, 18 = Denmark, 20 = Poland, 21 = Portugal, 23 = Greece, 24 = Ireland, 26 = Slovenia, 27 = Slovakia, 29 = Estonia, 32 = Latvia, 36 = Lithuania, 49 = Cyprus, 50 = Malta.
- (14) The test points shall be selected using approved statistical methods of randomisation.
- (15) The test points shall be selected using approved statistical methods of randomisation.
- (16) The test points shall be selected using approved statistical methods of randomisation.
- (17) Based on C1 equivalent.
- (18) The value is only valid for the reference fuel specified in Annex IV.
- (19) Based on C1 equivalent.
- (20) Delete as appropriate.
- (21) Stoichiometric Air/Fuel ratios of automotive fuels - SAE J1829, June 1987. John B. Heywood, Internal combustion engine fundamentals, McGraw-Hill, 1988, Chapter 3.4 'Combustion stoichiometry' (pp. 68 to 72).
- (22) Based on C1 equivalent.
- (23) Based on C1 equivalent.