

This document is meant purely as documentation tool and the institutions do not assume any liability for its contents

►B **DIRECTIVE 96/79/EC OF THE EUROPEAN PARLIAMENT AND OF THE COUNCIL**
of 16 December 1996
on the protection of occupants of motor vehicles in the event of a frontal impact and amending Directive
70/156/EEC
(OJ L 18, 21.1.1997, p. 7)

Corrected by:

►C1 Corrigendum, OJ L 83, 25.3.1997, p. 23 (96/79)



**DIRECTIVE 96/79/EC OF THE EUROPEAN PARLIAMENT AND OF
THE COUNCIL
of 16 December 1996
on the protection of occupants of motor vehicles in the event of a frontal
impact and amending Directive 70/156/EEC**

THE EUROPEAN PARLIAMENT AND THE COUNCIL OF THE EUROPEAN UNION,

Having regard to the Treaty establishing the European Community, and in particular Article 100a thereof,

Having regard to Council Directive 70/156/EEC of 6 February 1970 on the approximation of the laws of the Member States relating to the type-approval of motor vehicles and their trailers ⁽¹⁾, and in particular Article 13 (4) thereof,

Having regard to the proposal from the Commission ⁽²⁾,

Having regard to the opinion of the Economic and Social Committee ⁽³⁾,

Acting in accordance with the procedure laid down in Article 189b of the Treaty ⁽⁴⁾,

Whereas the total harmonization of technical requirements for motor vehicles is necessary in order fully to achieve the internal market;

Whereas, in order to reduce the number of road accident casualties in Europe, it is necessary to introduce legislative measures for improving the protection of occupants of motor vehicles in the event of a frontal impact as much as possible; whereas this Directive introduces frontal impact test requirements, including biomechanical criteria, to ensure that a high level of protection in the event of a frontal impact is provided;

Whereas the aim of this Directive is to introduce requirements based on the results of research conducted by the European Experimental Vehicles Committee allowing the establishment of test criteria which are more representative of actual road accidents;

Whereas lead times are required by vehicle manufacturers for the implementation of acceptable test criteria;

Whereas, to avoid duplication of standards, it is necessary to exempt vehicles which comply with the requirements of this Directive from the need to comply with now superseded requirements in another Directive in respect of the behaviour of the steering wheel and column in an impact;

Whereas this Directive will be one of the separate directives which must be complied with in order to ensure the conformity of vehicles with the requirements of the EC type-approval procedure established by Directive 70/156/EEC; whereas, therefore, the provisions of Directive 70/156/EEC relating to vehicle systems, components and separate technical units apply to this Directive;

Whereas the procedure for determining the seating reference point in motor vehicles is given in Annex III to Council Directive 77/649/EEC of 27 September 1977 on the approximation of the laws of the Member States relating to the field of vision of motor vehicle drivers ⁽⁵⁾; whereas it is therefore unnecessary to repeat it in this Directive; whereas reference should be made in this Directive to Council Directive 74/297/EEC of 4 June 1974 on the approximation of the laws of the Member States relating to the interior

⁽¹⁾ OJ No L 42, 23. 2. 1970, p. 1. Directive as last amended by Commission Directive 95/54/EC (OJ No L 266, 8. 11. 1995, p. 1).

⁽²⁾ OJ No C 396, 31. 12. 1994, p. 34.

⁽³⁾ OJ No C 256, 2. 10. 1995, p. 21.

⁽⁴⁾ Opinion of the European Parliament of 12 July 1995 (OJ No C 249, 25. 9. 1995, p. 50), Council common position of 28 May 1996 (OJ No C 219, 27. 7. 1996, p. 22) and Decision of the European Parliament of 19 September 1996 (OJ No C 320, 28. 10. 1996, p. 149). Council Decision of 25 October 1996.

⁽⁵⁾ OJ No L 267, 19. 10. 1977, p. 1. Directive as last amended by Commission Directive 90/630/EEC (OJ No L 341, 6. 12. 1990, p. 20).



fittings of motor vehicles (the behaviour of the steering mechanism in the event of an impact)⁽¹⁾; whereas reference is made to the United States of America Code of Federal Regulations⁽²⁾,

HAVE ADOPTED THIS DIRECTIVE:

Article 1

For the purposes of this Directive, 'vehicle' shall have the meaning given to it in Article 2 of Directive 70/156/EEC.

Article 2

1. No Member State may, on grounds concerning the protection of occupants of vehicles in the event of a frontal impact:

— refuse, in respect of a vehicle type, to grant EC type-approval or national type-approval, or

— prohibit the registration, sale or entry into service of a vehicle,

if it complies with the requirements of this Directive.

2. With effect from 1 October 1998, Member States:

— may no longer grant EC type-approval for a vehicle type in accordance with Article 4 of Directive 70/156/EEC,

— may refuse national type-approval for a vehicle type,

unless the vehicle satisfies the requirements of this Directive.

3. Paragraph 2 shall not apply to vehicle types approved before 1 October 1998 pursuant to Directive 74/297/EEC, or to subsequent extensions to that type-approval.

4. Vehicles type-approved in accordance with this Directive shall be regarded as satisfying the requirements of paragraph 5.1 of Annex I to Directive 74/297/EEC.

5. With effect from 1 October 2003, Member States:

— shall consider certificates of conformity which accompany new vehicles in accordance with Directive 70/156/EEC to be no longer valid for the purposes of Article 7 (1) of that Directive, and

— may refuse the registration, sale or entry into service of new vehicles which are not accompanied by a certificate of conformity in accordance with Directive 70/156/EEC,

if the requirements of this Directive, including paragraphs 3.2.1.2 and 3.2.1.3 of Annex II, are not fulfilled.

Article 3

In Part I of Annex IV to Directive 70/156/EEC, the table shall be supplemented as follows:

| | Subject | Directive No | OJ reference | Applicability | | | | | | | | | | |
|----|---------------------------|--------------|--------------|----------------|----------------|----------------|----------------|----------------|----------------|----------------|----------------|----------------|----------------|--|
| | | | | M ₁ | M ₂ | M ₃ | N ₁ | N ₂ | N ₃ | O ₁ | O ₂ | O ₃ | O ₄ | |
| 53 | Frontal impact resistance | 96/.../EC | L ... | X | | | | | | | | | | |

⁽¹⁾ OJ No L 165, 20. 6. 1974, p. 16. Directive as last amended by Commission Directive 91/662/EEC (OJ No L 366, 31. 12. 1991, p. 1).

⁽²⁾ United States of America Code of Federal Regulations, Title 49, Chapter V, Part 572.



Article 4

In the framework of the adaptation of this Directive to technical progress, the Commission shall:

- (a) review the Directive, within two years from the date mentioned in Article 5 (1), with a view to increasing the test speed and including vehicles of category N₁. The review will cover *inter alia* accident research data, full-scale car-to-car test results, cost-benefit considerations and, in particular, the existing performance requirements (both biomechanical and geometric) and the addition of new requirements relating to footwell intrusion. The review will examine the potential gains in occupant protection and the industrial feasibility of increasing the test speed and extending the scope of the Directive to include vehicles of category N₁. The results of this review will be submitted to the European Parliament and the Council in a report drawn up by the Commission;
- (b) before the end of 1996 review, and, if appropriate, amend Appendix 7 to Annex II so as to take into account assessment tests on the Hybrid III dummy's ankle including vehicle tests;
- (c) before the end of 1997, review and, if appropriate, amend the limit values for neck injury (as specified in paragraphs 3.2.1.2 and 3.2.1.3 of Annex II) on the basis of the values recorded during type-approval tests and on accident study and biomechanical research data;
- (d) also make, before the end of 1997, the necessary amendments to the separate Directives so as to ensure the compatibility of the type-approval and extension procedures provided by the directives with those in this Directive.

Article 5

1. Member States shall bring into force the laws, regulations and administrative provisions necessary to comply with this Directive no later than **►C1** 1 April 1997. They **◄** shall forthwith inform the Commission thereof.

When Member States adopt these provisions, they shall contain a reference to this Directive or shall be accompanied by such reference on the occasion of their official publication. The methods of making such reference shall be laid down by Member States.

2. Member States shall communicate to the Commission the texts of the main provisions of national law which they adopt in the field covered by this Directive.

3. Member States shall take the measures necessary to ensure that the results of the type-approval tests carried out by their approval authorities are made available to the public.

Article 6

This Directive shall enter into force on the twentieth day following that of its publication in the *Official Journal of the European Communities*.

Article 7

This Directive is addressed to the Member States.

*LIST OF ANNEXES*Annex I **Administrative provisions for the type-approval of a vehicle type**

1. Application for EC type-approval
 2. EC type-approval
 3. Modifications of the type and amendments to type-approvals
 4. Conformity of production
- Appendix 1: Information document
- Appendix 2: EC type-approval certificate

Annex II **Technical requirements**

1. Scope
 2. Definitions
 3. Requirements
- Appendix 1: Test procedure
- Appendix 2: Determination of performance criteria
- Appendix 3: Arrangement and installation of dummies and adjustment of restraint systems
- Appendix 4: Test procedure with trolley
- Appendix 5: Technique of measurement in measurement tests: instrumentation
- Appendix 6: Definition of the deformable barrier
- Appendix 7: Certification procedure for the dummy lower leg and foot

*ANNEX I***ADMINISTRATIVE PROVISIONS FOR THE TYPE-APPROVAL OF A VEHICLE TYPE**

1. APPLICATION FOR EC TYPE-APPROVAL
 - 1.1. Applications for EC type-approval pursuant to Article 3 (4) of Directive 70/156/EEC of a vehicle type with regard to the protection of occupants of motor vehicles in the event of a frontal impact must be submitted by the manufacturer.
 - 1.2. A model for the information document is given in Appendix 1.
 - 1.3. A vehicle representative of the vehicle type to be approved must be submitted to the technical service responsible for conducting the type-approval tests.
 - 1.4. The manufacturer is entitled to submit any data and test results which make it possible to establish with a sufficient degree of confidence that compliance with the requirements can be achieved.
2. EC TYPE-APPROVAL
 - 2.1. Where the vehicle type satisfies the relevant requirements, EC type-approval pursuant to Article 4 (3) and, if applicable, Article 4 (4) of Directive 70/156/EEC will be granted.
 - 2.2. A model for the type-approval certificate is given in Appendix 2.
 - 2.3. A type-approval number in accordance with Annex VII to Directive 70/156/EEC is assigned to each vehicle type approved. The same Member State must not assign the same number to another type of vehicle.
 - 2.4. In case of doubt, in order to verify that the vehicle conforms to the requirements of this Directive, account must be taken of any data or test results provided by the manufacturer which may be taken into consideration in establishing the validity of the type-approval test performed by the type-approval authority.
3. MODIFICATION OF THE TYPE AND AMENDMENTS TO TYPE-APPROVALS
 - 3.1. In the case of modification of a vehicle type approved pursuant to this Directive, the provisions of Article 5 of Directive 70/156/EEC are applicable.
 - 3.2. Any modification of the vehicle affecting the general form of the structure of the vehicle and/or any increase in mass greater than 8 % which, in the judgment of the technical service, would have a marked influence on the results of the tests necessitates a repetition of the test as described in Appendix I to Annex II.
 - 3.3. If the modifications concern only the interior fittings, if the mass does not differ by more than 8 % and if the number of front seats initially provided in the vehicle remains the same, the following will need to be carried out:
 - 3.3.1. a simplified test as provided for in Appendix 4 to Annex II, and/or
 - 3.3.2. a partial test as determined by the technical service in the light of the modifications made.
4. CONFORMITY OF PRODUCTION
 - 4.1. As a general rule, measures to ensure the conformity of production must be taken in accordance with the provisions laid down in Article 10 of Directive 70/156/EEC.

*Appendix 1***Information document No ...****pursuant to Annex I to Directive 70/156/EEC⁽¹⁾ relating to the EC type-approval of a vehicle with regard to the protection of occupants of motor vehicles in the event of a frontal impact**

The following information, if applicable, must be supplied in triplicate and include a list of contents. Any drawings must be supplied in appropriate scale and in sufficient detail on size A4 or on a folder of A4 format. Photographs, if any, must show sufficient detail.

If the systems, components or separate technical units have electronic controls, information concerning their performance must be supplied.

0. **General**
 - 0.1. Make (trade name of manufacturer):
 - 0.2. Type and general commercial description(s):
 - 0.3. Means of identification of type, if marked on the vehicle ^(b):
 - 0.3.1. Location of that marking:
 - 0.4. Category of vehicle ^(c):
 - 0.5. Name and address of manufacturer:
 - 0.8. Address(es) of assembly plant(s):
1. **General construction characteristics of the vehicle**
 - 1.1. Photographs and/or drawings of a representative vehicle:
 - 1.6. Position and arrangement of the engine:
 2. **Masses and dimensions** ^(c) (in kg and mm) (refer to drawing where applicable)
 - 2.4. Range of vehicle dimensions (overall):
 - 2.4.2. Chassis with bodywork:
 - 2.4.2.1. Length ⁽ⁱ⁾:
 - 2.4.2.2. Width ^(k):
 - 2.4.2.6. Ground clearance (as defined in paragraph 4.5.4 of Section A of Annex II to Directive 70/156/EEC):
 - 2.4.2.7. Distance between axles:
 - 2.6. Mass of the vehicle with bodywork in running order, or mass of the chassis with cab if the manufacturer does not fit the bodywork (including coolant, oils, fuel, tools, spare wheel and driver) ^(o) (maximum and minimum for each version):
 - 2.6.1. Distribution of this mass among the axles and, in the case of a semi-trailer or centre-axle trailer, load on the coupling point (maximum and minimum for each version):
 7. **Steering**
 - 7.2. Mechanism and control:
 - 7.2.6. Range and method of adjustment, if any, of the steering control:
 9. **Bodywork**
 - 9.1. Type of bodywork:
 - 9.2. Materials used and methods of construction:
 - 9.10. Interior fittings:
 - 9.10.3. Seats:
 - 9.10.3.1. Number:
 - 9.10.3.2. Position and arrangement:

⁽¹⁾ The item numbers and footnotes used in this information document correspond to those set out in Annex I to Directive 70/156/EEC. Items not relevant for the purposes of this Directive are omitted.

▼B

9.10.3.5. Coordinates or drawing of the 'R' point (*):

9.10.3.5.1. Driver's seat:

9.10.3.6. Design seat-back angle:

9.10.3.6.1. Driver's seat:

9.10.3.6.2. All other seating positions (*):

9.10.3.7. Range of seat adjustment:

9.10.3.7.1. Driver's seat

horizontally vertically

9.10.3.7.2. All other seating positions (*)

horizontally vertically

9.12. Safety belts and/or other restraint systems

9.12.1. Number and position of safety belts and restraint systems and seats on which they can be used:

| R/C/L | Complete EC type-approval mark | Variant, if applicable |
|-------|--|------------------------|
| | First row of seats Second row of seats, etc. Optional extras (e.g. for height-adjusting seats, pre-loading device, etc.) | |

(R = right-hand seat, c = centre seat, L = left-hand seat)

9.12.2. Front seat airbags:

— driver's side yes/no/optional ⁽¹⁾

— passenger side yes/no/optional ⁽¹⁾

— centre yes/no/optional ⁽¹⁾

9.12.3. Number and position of safety-belt anchorages and proof of compliance with Directive 76/115/EEC, as amended (i.e. type-approval number or test report) (**):

Date, file

(*) Only the front passenger seat.

(**) Only the outboard front seats.

⁽¹⁾ Delete where not applicable.



Appendix 2

MODEL

(maximum format: A4 (210 × 297 mm))

EC TYPE-APPROVAL CERTIFICATE

| |
|-------------------------------------|
| Stamp of type-approval authority |
|-------------------------------------|

Communication concerning the

- type-approval⁽¹⁾
- extension of type-approval⁽¹⁾
- refusal of type-approval⁽¹⁾
- withdrawal of type-approval⁽¹⁾

of a type of vehicle/component/separate technical unit⁽¹⁾ with regard to Directive .../.../EC, as last amended by Directive .../.../EC.

Type-approval number:

Reason for extension:

PART I

- 0.1. Make (trade name of manufacturer):
- 0.2. Type and general commercial description(s):
- 0.3. Means of identification of type, if marked on the vehicle/component/separate technical unit^{(1)(?)}:
 - 0.3.1. Location of that marking:
- 0.4. Category of vehicle⁽³⁾:
- 0.5. Name and address of manufacturer:
- 0.7. In the case of components and separate technical units, location and method of affixing of the EC type-approval mark:
- 0.8. Address(es) of assembly plant(s):

PART II

1. Additional information (where applicable): (see Addendum)
2. Technical service responsible for carrying out the tests:
3. Date of test report:
4. Number of test report:
5. Remarks (if any): (see Addendum)
6. Place:

⁽¹⁾ Delete where not applicable.

⁽²⁾ If the means of identification of type contain characters not relevant to a description of the vehicle, component or separate technical unit types covered by this type-approval certificate, such characters shall be presented in the documentation by the symbol '?' (e.g. ABC??123??).

⁽³⁾ As defined in Annex II A to Directive 70/156/EEC.

▼B

7. Date:
8. Signature:
9. The index to the type-approval file sent to the competent authority, which may be obtained on request, is attached.

Addendum

to EC type-approval certificate No ...
concerning the type-approval of a vehicle with regard to Directive .../.../EC

1. *Additional information*
 - 1.1. Brief description of the vehicle type as regards its structure, dimensions, lines and constituent materials:
 - 1.2. Description of the protective system installed in the vehicle:
 - 1.3. Description of the interior arrangements or fittings that might affect the tests:
 - 1.4. Location of engine: forward/rear/central⁽¹⁾
 - 1.5. Drive: front-wheel/rear-wheel⁽¹⁾
 - 1.6. Mass of vehicle submitted for testing
 - Front axle:
 - Rear axle:
 - Total:
 5. Remarks: (e.g. valid for left-hand drive and right-hand drive vehicles)
 6. Front seat airbags:
 - driver's side yes/no⁽¹⁾
 - passenger side yes/no⁽¹⁾
 - centre yes/no⁽¹⁾
- ⁽¹⁾ Delete where not applicable.

⁽¹⁾ Delete where not applicable.



ANNEX II

TECHNICAL REQUIREMENTS

1. SCOPE

- 1.1. This Directive applies to power-driven vehicles of category M₁ of a total permissible mass not exceeding 2,5 tonnes, with the exception of multi-stage built vehicles produced in quantities not exceeding those fixed for a small series; heavier vehicles and multi-stage built vehicles may be approved at the request of the manufacturer.

2. DEFINITIONS

For the purposes of this Directive:

- 2.1. 'protective system' means interior fittings and devices intended to restrain the occupants and contribute towards ensuring compliance with the requirements set out in paragraph 3 below;
- 2.2. 'type of protective system' means a category of protective devices which do not differ in such essential respects as:
- their technology,
 - their geometry,
 - their constituent materials;
- 2.3. 'vehicle width' means the distance between two planes parallel to the longitudinal median plane and touching the vehicle on either side of the said plane but excluding the rear-view mirrors, side marker lamps, tyre pressure indicators, direction indicator lamps, position lamps, flexible mud-guards and the deflected part of the tyre side-walls immediately above the point of contact with the ground;
- 2.4. 'overlap' means the percentage of the vehicle width directly in line with the barrier face;
- 2.5. 'deformable barrier face' means a crushable section mounted on the front of a rigid block;
- 2.6. 'vehicle type' means a category of power-driven vehicles which do not differ in such essential respects as:
- 2.6.1. the length and width of the vehicle, insofar as they have a negative effect on the results of the impact test prescribed in this Directive;
 - 2.6.2. the structure, dimensions, lines and materials of the part of the vehicle forward of the transverse plane through the 'R' point of the driver's seat insofar as they have a negative effect on the results of the impact test prescribed in this Directive;
 - 2.6.3. the lines and inside dimensions of the passenger compartment and the type of protective system, insofar as they have a negative effect on the results of the impact test prescribed in this Directive;
 - 2.6.4. the location (front, rear or centre) and the orientation (transversal or longitudinal) of the engine;
 - 2.6.5. the unladen mass, insofar as it has a negative effect on the results of the impact test prescribed in this Directive;
 - 2.6.6. the optional arrangements or fittings provided by the manufacturer, insofar as they have a negative effect on the results of the impact test prescribed in this Directive;
- 2.7. 'passenger compartment' means the space for occupant accommodation, bounded by the roof, floor, side walls, doors, outside glazing and front bulkhead and the plane of the rear compartment bulkhead or the plane of the rear-seat back support;
- 2.8. 'R' point means a reference point defined for each seat by the manufacturer in relation to the vehicle's structure;
- 2.9. 'H' point means a reference point determined for each seat by the technical service responsible for approval;
- 2.10. 'unladen kerb mass' means the mass of the vehicle in running order, unoccupied and unladen but complete with fuel, coolant, lubricant, tools and a spare wheel (if these are provided as standard equipment by the vehicle manufacturer);

▼B

- 2.11. 'airbag' means a device installed to supplement safety belts and restraint systems in motor vehicles, i.e. systems which, in the event of a severe impact affecting the vehicle, automatically deploy a flexible structure intended to limit, by compression of the gas contained within it, the gravity of the contacts of one or more parts of the body of an occupant of the vehicle with the interior of the passenger compartment.

3. REQUIREMENTS

3.1. General specification applicable to all tests

- 3.1.1. The 'H' point for each seat is determined in accordance with the procedure described in Annex II to Directive 77/649/EEC.

3.2. Specifications

- 3.2.1. The performance criteria recorded, in accordance with Appendix 5, on the dummies in the front outboard seats must meet the following conditions:
- 3.2.1.1. the head performance criterion (HPC) must not exceed 1 000 and the resultant head acceleration shall not exceed 80 g for more than 3 ms. The latter must be calculated cumulatively, excluding rebound movement of the head;
- 3.2.1.2. the neck injury criteria (NIC) must not exceed the values shown in Figures 1 and 2⁽¹⁾;
- 3.2.1.3. the neck bending moment about the y axis must not exceed 57 Nm in extension⁽¹⁾;
- 3.2.1.4. the thorax compression criterion (ThCC) must not exceed 50 mm;
- 3.2.1.5. the viscous criterion (V*C) for the thorax must not exceed 1,0 m/s;
- 3.2.1.6. the femur force criterion (FFC) must not exceed the force-time performance criterion shown in Figure 3 of this Annex;
- 3.2.1.7. the tibia compression force criterion (TCFC) must not exceed 8 kN;
- 3.2.1.8. the tibia index (TI), measured at the top and bottom of each tibia, must not exceed 1,3 at either location;
- 3.2.1.9. the movement of the sliding knee joints must not exceed 15 mm.
- 3.2.2. Residual steering wheel displacement, measured at the centre of the steering wheel hub, must not exceed 80 mm in the upwards vertical direction and 100 mm in the rearward horizontal direction.
- 3.2.3. During the test no door may open.
- 3.2.4. During the test no locking of the locking systems of the front doors may occur.
- 3.2.5. After the impact, it must be possible, without the use of tools, except for those necessary to support the weight of the dummy:
- 3.2.5.1. to open at least one door, if there is one, per row of seats and, where there is no such door, to move the seats or tilt their backrests as necessary to allow the evacuation of all the occupants; this is, however, only applicable to vehicles having a roof of rigid construction;
- 3.2.5.2. to release the dummies from their restraint system which, if locked, must be capable of being released by a maximum force of 60 N on the centre of the release control;
- 3.2.5.3. to remove the dummies from the vehicle without adjustment of the seats.
- 3.2.6. In the case of a vehicle propelled by liquid fuel, no more than slight leakage of liquid from the entire fuel system may occur during or after the impact. If after the impact there is continuous leakage of liquid from any part of the fuel system, the rate of leakage must not exceed 5×10^{-4} kg/s; if the liquid from the fuel-feed system mixes with liquids from the other systems and the various liquids cannot easily be separated and identified, all the liquids collected are taken into account in evaluating the continuous leakage.

⁽¹⁾ Until the date mentioned in Article 2 (2), the values obtained for the neck shall not be pass/fail criteria for the purposes of granting type-approval. The results obtained shall be recorded in the test report and be collected by the approval authority. After this date, the value(s) specified in this paragraph shall apply as pass/fail criteria unless or until alternative values are adopted in accordance with the provisions of Article 4 (c).

▼B

Figure 1
Neck tension criterion

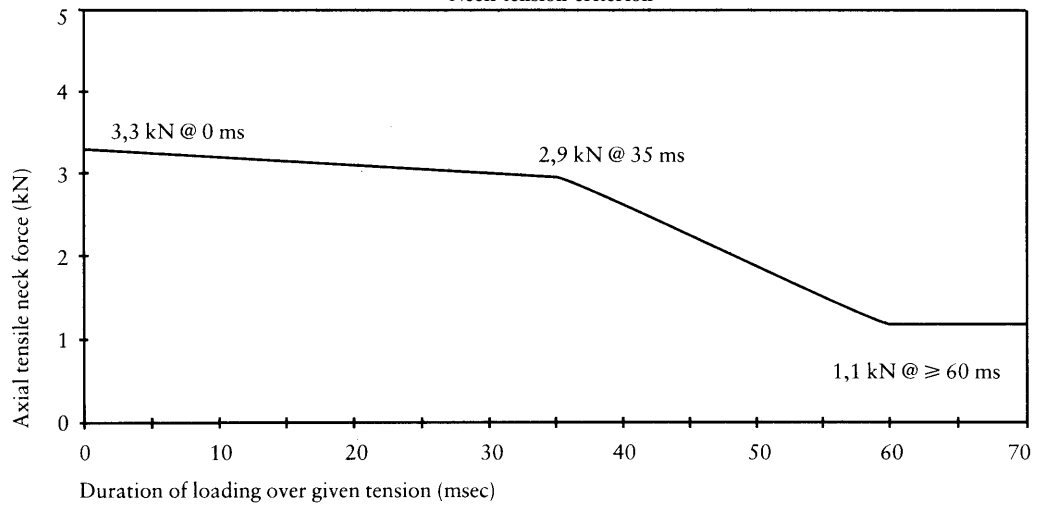

Figure 2
Neck shear criterion

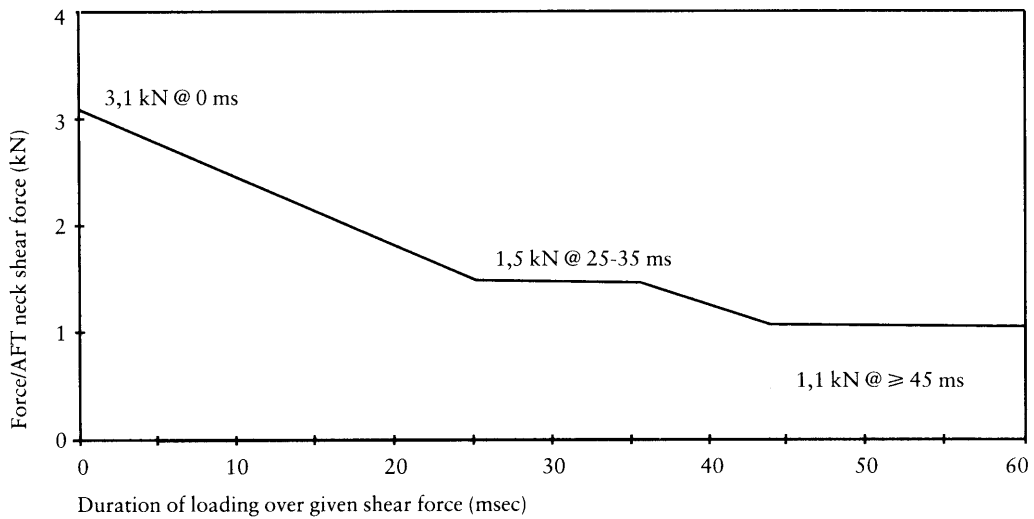
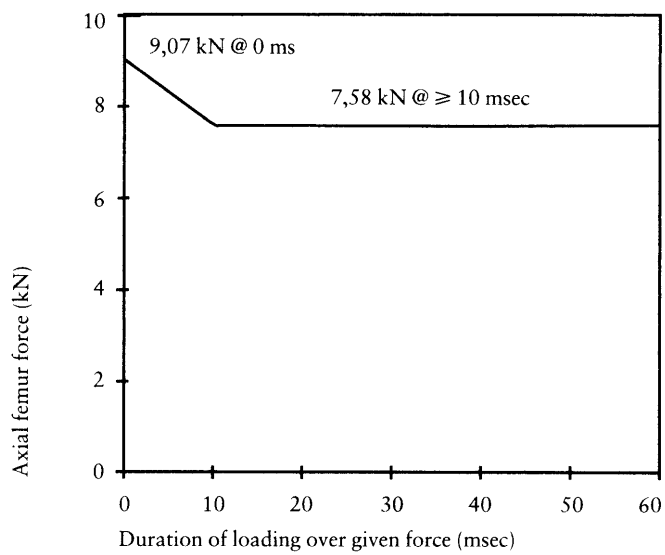

Figure 3
Femur force criterion





Appendix 1

TEST PROCEDURE

1. INSTALLATION AND PREPARATION OF THE VEHICLE
 - 1.1. **Testing ground**

The test area must be large enough to accommodate the run-up track, barrier and technical installations necessary for the test. The last part of the track, for at least 5 m before the barrier, must be horizontal, flat and smooth.
 - 1.2. **Barrier**

The front face of the barrier consists of a deformable structure as defined in Appendix 6 of this Annex. The front face of the deformable structure is perpendicular $\pm 1^\circ$ to the direction of travel of the test vehicle. The barrier is secured to a mass of not less than 7×10^4 kg, the front face of which is vertical $\pm 1^\circ$. This mass is anchored in the ground or placed on the ground with, if necessary, additional arresting devices to restrict its movement.
 - 1.3. **Orientation of the barrier**

The orientation of the barrier is such that the first contact of the vehicle with the barrier is on the steering-column side. Where there is a choice between carrying out the test with a right-hand or left-hand drive vehicle, the test must be carried out with the less favourable hand of drive as determined by the technical service responsible for the tests.

 - 1.3.1. *Alignment of the vehicle to the barrier*

The vehicle must overlap the barrier face by 40 % ± 20 mm.
 - 1.4. **State of vehicle**
 - 1.4.1. *General specification*

The test vehicle must be representative of the series production, include all the equipment normally fitted and be in normal running order. Some components may be replaced by equivalent masses where this substitution clearly has no noticeable effect on the results measured under paragraph 6.
 - 1.4.2. *Mass of the vehicle*
 - 1.4.2.1. For the test, the mass of the vehicle submitted must be the unladen kerb mass.
 - 1.4.2.2. The fuel tank must be filled with water up to 90 % of the mass of a full load of fuel as specified by the manufacturer with a ± 1 % tolerance.
 - 1.4.2.3. All the other systems (brakes, cooling, etc.) may be empty; in this case the mass of the liquids must be offset.
 - 1.4.2.4. If the mass of the measuring apparatus on board the vehicle exceeds the 25 kg allowed, it may be offset by reductions which have no noticeable effect on the results measured under paragraph 6 below.
 - 1.4.2.5. The mass of the measuring apparatus must not change each axle reference load by more than 5 %, each variation not exceeding 20 kg.
 - 1.4.2.6. The mass of the vehicle resulting from the provisions of paragraph 1.4.2.1 above must be indicated in the report.
 - 1.4.3. *Passenger compartment adjustments*
 - 1.4.3.1. **Position of steering wheel**

The steering wheel, if adjustable, must be placed in the normal position indicated by the manufacturer or, failing that, midway between the limits of its range(s) of adjustment. At the end of propelled travel, the steering wheel must be left free, with its spokes in the position which according to the manufacturer corresponds to straight-ahead travel of the vehicle.
 - 1.4.3.2. **Glazing**

The movable glazing of the vehicle must be in the closed position. For test measurement purposes and in agreement with the manufacturer, it may be lowered, provided that the position of the operating handle corresponds to the closed position.

▼B

1.4.3.3. Gear-change lever

The gear-change lever must be in the neutral position.

1.4.3.4. Pedals

The pedals must be in their normal position of rest. If adjustable, they must be set in their mid position unless another position is specified by the manufacturer.

1.4.3.5. Doors

The doors must be closed, but not locked.

1.4.3.6. Opening roof

If an opening or removable roof is fitted, it must be in place and in the closed position. For test measurement purposes and in agreement with the manufacturer, it may be open.

1.4.3.7. Sun-visor

The sun-visors must be in the stowed position.

1.4.3.8. Rear-view mirror

The interior rear-view mirror must be in the normal position of use.

1.4.3.9. Arm-rests

Arm-rests at the front and rear, if movable, must be in the lowered position, unless this is prevented by the position of the dummies in the vehicles.

1.4.3.10. Head restraints

Head restraints adjustable for height must be in their uppermost position.

1.4.3.11. Seats

1.4.3.11.1. Position of front seats

Seats adjustable longitudinally must be placed so that their 'H' point, (see 3.1.1) is in the middle position of travel or in the nearest locking position thereto, and at the height position defined by the manufacturer (if independently adjustable for height).

In the case of a bench seat, the reference must be to the 'H' point of the driver's place.

1.4.3.11.2. Position of the front seat-backs

If adjustable, the seat-backs must be adjusted so that the resulting inclination of the torso of the dummy is as close as possible to that recommended by the manufacturer for normal use or, in the absence of any particular recommendation by the manufacturer, to 25° towards the rear from the vertical.

1.4.3.11.3. Rear seats

If adjustable, the rear seats or rear bench seats must be placed in the rearmost position.

2. DUMMIES

2.1. Front seats

2.1.1. A dummy corresponding to the specifications for Hybrid III⁽¹⁾ fitted with a 45° ankle and meeting the specifications for its adjustment is installed in each of the front outboard seats in accordance with the conditions set out in Appendix 3. The dummy is equipped for recording the data necessary to determine the performance criteria with measuring systems corresponding to the specifications in Appendix 5. The ankle of the dummy must be certified in accordance with the procedures in Appendix 7 to Annex II.

2.1.2. The car will be tested with restraint systems, as provided by the manufacturer.

⁽¹⁾ The technical specifications and detailed drawings of Hybrid III, corresponding to the principal dimensions of a 50th percentile male of the United States of America, and the specifications for its adjustment for this test are deposited with the Secretary-General of the United Nations and may be consulted on request at the secretariat of the Economic Commission for Europe, Palais des Nations, Geneva, Switzerland.

▼B

3. PROPULSION AND COURSE OF VEHICLE
 - 3.1. The vehicle must be propelled either by its own engine or by any other propelling device.
 - 3.2. At the moment of impact the vehicle must no longer be subject to the action of any additional steering or propelling device.
 - 3.3. The course of the vehicle must be such that it satisfies the requirements of 1.2 and 1.3.1.
4. TEST SPEED

Vehicle speed at the moment of impact must be $56 - 0 + 1$ km/h. However, if the test was performed at a higher speed and the vehicle met the requirements, the test is considered satisfactory.
5. MEASUREMENTS TO BE MADE ON DUMMY IN FRONT SEATS
 - 5.1. All the measurements necessary for the verification of the performance criteria must be made with data channels corresponding to the specifications of Appendix 5.
 - 5.2. The different parameters are recorded through independent data channels of the following CFC (Channel Frequency Class):
 - 5.2.1. *Measurements in the head of the dummy*

The acceleration (a) referring to the centre of gravity is calculated from the triaxial components of the acceleration measured with a CFC of 1 000.
 - 5.2.2. *Measurements in the neck of the dummy*
 - 5.2.2.1. The axial tensile force and the fore/aft shear force at the neck/head interface are measured with a CFC of 1 000.
 - 5.2.2.2. The bending moment about a lateral axis at the neck/head interface is measured with a CFC of 600.
 - 5.2.3. *Measurements in the thorax of the dummy*

The chest deflection between the sternum and the spine is measured with a CFC of 180.
 - 5.2.4. *Measurements in the femur and tibia of the dummy*
 - 5.2.4.1. The axial compressive force and the bending moments are measured with a CFC of 600.
 - 5.2.4.2. The displacement of the tibia with respect to the femur is measured at the knee sliding joint with a CFC of 180.
6. MEASUREMENTS TO BE MADE ON THE VEHICLE
 - 6.1. To enable the simplified test described in Appendix 4 to be carried out, the deceleration curve of the structure must be determined on the basis of the value of the longitudinal accelerometers at the base of the 'B' pillar on the struck side of the vehicle with a CFC of 180 by means of data channels corresponding to the requirements set out in Appendix 5.
 - 6.2. The speed curve which will be used in the test procedure described in Appendix 4 must be obtained from the longitudinal accelerometer at the 'B' pillar on the side struck.



Appendix 2

DETERMINATION OF PERFORMANCE CRITERIA

1. HEAD PERFORMANCE CRITERION (HPC)

1.1. This criterion is considered to be satisfied when, during the test, there is no contact between the head and any vehicle component.

1.2. If that is not the case, a calculation of the value of HPC is made, on the basis of the acceleration (a), measured according to section 5.2.1 of Appendix 1 to this Annex, by the following expression:

$$\text{HPC} = (t_2 - t_1) \left[\frac{1}{t_2 - t_1} \int_{t_1}^{t_2} a dt \right]^{2,5}$$

in which:

1.2.1. the term 'a' is the resultant acceleration measured according to paragraph 5.2.1 of Appendix 1 to this Annex and is measured in units of gravity, g (1 g = 9,81 m/s²);

1.2.2. if the beginning of the head contact can be determined satisfactorily, t₁ and t₂ are the two time instants, expressed in seconds, defining an interval between the beginning of the head contact and the end of the recording for which the value of HPC is maximum;

1.2.3. if the beginning of the head contact cannot be determined, t₁ and t₂ are the two time instants, expressed in seconds, defining a time interval between the beginning and the end of the recording for which the value of HPC is maximum.

1.2.4. Values of HPC for which the time interval (t₁ - t₂) is greater than 36 ms are ignored for the purposes of calculating the maximum value.

1.3. The value of the resultant head acceleration during forward impact which is exceeded for 3 ms cumulatively is calculated from the resultant head acceleration measured according to paragraph 5.2.1 of Appendix 1 to this Annex.

2. NECK INJURY CRITERIA (NIC)

2.1. These criteria are determined by the compressive axial force, the axial tensile force and the fore/aft shear forces at the head/neck interface, expressed in kN and measured according to paragraph 5.2.2 of Appendix 1 to this Annex and by the duration of these forces expressed in ms.

2.2. The neck bending moment criterion is determined by the bending moment, expressed in Nm, about a lateral axis at the head/neck interface and measured according to paragraph 5.2.2 of Appendix 1 to this Annex.

2.3. The neck flexion bending moment, expressed in Nm, must be recorded.

3. THORAX COMPRESSION CRITERION (ThCC) AND VISCOUS CRITERION (V*C)

3.1. The thorax compression criterion is determined by the absolute value of the thorax deformation, expressed in mm and measured according to paragraph 5.2.3 of Appendix 1 to this Annex.

3.2. The viscous criterion (V*C) is calculated as the instantaneous product of the compression and the rate of deflection of the sternum, measured according to paragraph 6 and also paragraph 5.2.3 of Appendix 1 to this Annex.

4. FEMUR FORCE CRITERION (FFC)

4.1. This criterion is determined by the compression load expressed in kN, transmitted axially on each femur of the dummy and measured according to paragraph 5.2.4 of Appendix 1 to this Annex and by the duration of the compressive load expressed in ms.

▼B

5. TIBIA COMPRESSIVE FORCE CRITERION (TCFC) AND TIBIA INDEX (TI)

5.1. The tibia compressive force criterion is determined by the compressive load (F_z) expressed in kN, transmitted axially on each tibia of the dummy and measured according to paragraph 5.2.4 of Appendix 1 to Annex II.

5.2. The tibia index is calculated on the basis of the bending moments (M_x and M_y) measured according to paragraph 5.1 by the following expression:

$$TI = |M_R/(M_C)_R| + |F_z/(F_C)_z|$$

where:

M_x = bending moment about the x axis

M_y = bending moment about the y axis

$(M_C)_R$ = critical bending moment and shall be taken to be 225 Nm

F_z = compressive axial force in the z direction

$(F_C)_z$ = critical compressive force in the z direction and shall be taken to be 35,9 kN

$$M_R = \sqrt{(M_x)^2 + (M_y)^2}$$

The tibia index is calculated for the top and the bottom of each tibia; however, F_z may be measured at either location. The value obtained is used for the top and bottom TI calculations. Moments M_x and M_y are both measured separately at both locations.

6. PROCEDURE FOR CALCULATING THE VISCOUS CRITERION (V*C) FOR HYBRID III DUMMY

6.1. The viscous criterion is calculated as the instantaneous product of the compression and the rate of deflection of the sternum. Both are derived from the measurement of sternum deflection.

6.2. The sternum deflection response is filtered once at CFC 180. The compression at time t is calculated from this filtered signal as:

$$C(t) = \frac{D(t)}{0,299}$$

The sternum deflection velocity at time t is calculated from the filtered deflection as:

$$V(t) = \frac{8 \times (D(t+1) - D(t-1)) - (D(t+2) - D(t-2))}{12\delta t}$$

where $D(t)$ is the deflection at time t in metres and δt is the time interval in seconds between the measurements of deflection. The maximum value of δt is $1,25 \times 10^{-4}$ seconds. This calculation procedure is shown diagrammatically below.

▼B

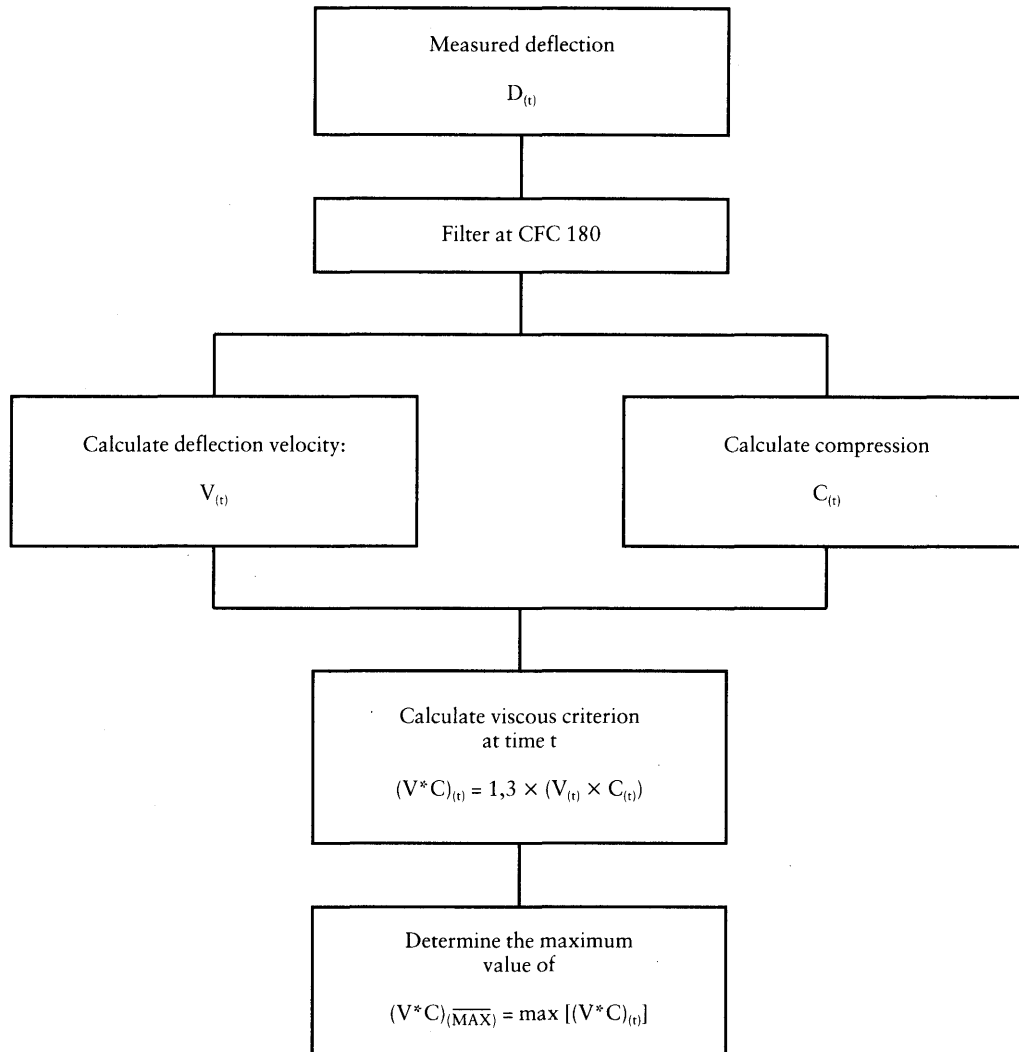



Appendix 3

ARRANGEMENT AND INSTALLATION OF DUMMIES AND ADJUSTMENT OF RESTRAINT SYSTEMS

1. ARRANGEMENT OF DUMMIES
 - 1.1. **Separate seats**

The plane of symmetry of the dummy must coincide with the vertical median plane of the seat.
 - 1.2. **Front bench seat**
 - 1.2.1. *Driver*

The plane of symmetry of the dummy must lie in the vertical plane passing through the steering wheel centre and parallel to the longitudinal median plane of the vehicle. If the seating position is determined by the shape of the bench, such seat must be regarded as a separate seat.
 - 1.2.2. *Outer passenger*

The plane of symmetry of the passenger dummy must be symmetrical with that of the driver dummy relative to the longitudinal median plane of the vehicle. If the seating position is determined by the shape of the bench, such seat must be regarded as a separate seat.
 - 1.3. **Bench seat for front passengers (not including driver)**

The planes of symmetry of the dummy must coincide with the median planes of the seating positions defined by the manufacturer.
2. INSTALLATION OF DUMMIES
 - 2.1. **Head**

The transverse instrumentation platform of the head must be horizontal within 2,5°. To level the head of the test dummy in vehicles with upright seats with non-adjustable backs, the following sequences must be followed. First adjust the position of the 'H'-point within the limits set forth in paragraph 2.4.3.1 of this Appendix to level the transverse instrumentation platform of the head of the test dummy. If the transverse instrumentation platform of the head is still not level, then adjust the pelvic angle of the test dummy within the limits provided in paragraph 2.4.3.2 of this appendix. If the transverse instrumentation platform of the head is still not level, then adjust the neck bracket of the test dummy the minimum amount necessary to ensure that the transverse instrumentation platform of the head is horizontal within 2,5°.
 - 2.2. **Arms**
 - 2.2.1. The upper arms of the driver test dummy must be adjacent to the torso with the centrelines as close to a vertical plane as possible.
 - 2.2.2. The upper arms of the passenger test dummy must be in contact with the seat back and the sides of the torso.
 - 2.3. **Hands**
 - 2.3.1. The palms of the driver test dummy must be in contact with the outer part of the steering wheel rim at the rim's horizontal centreline. The thumbs must be over the steering wheel rim and must be lightly taped to the steering wheel rim so that if the hand of the test dummy is pushed upward by a force of not less than 9 N and not more than 22 N, the tape releases the hand from the steering wheel rim.
 - 2.3.2. The palms of the passenger test dummy must be in contact with the outside of the thighs. The little finger must be in contact with the seat cushion.
 - 2.4. **Torso**
 - 2.4.1. In vehicles equipped with bench seats, the upper torso of the driver and passenger test dummies must rest against the seat back. The midsagittal plane of the driver dummy must be vertical and parallel to the vehicle's longitudinal centreline, and pass through the centre of the steering wheel rim. The midsagittal plane of the passenger dummy must be vertical and parallel to the vehicle's longitudinal centreline and the same distance from the vehicle's longitudinal centreline as the midsagittal plane of the driver dummy.

▼B

2.4.2. In vehicles equipped with individual seats, the upper torso of the driver and passenger test dummies must rest against the seat back. The midsagittal plane of the driver and the passenger dummy must be vertical and must coincide with the longitudinal centreline of the individual seat.

2.4.3. *Lower torso*

2.4.3.1. 'H' point

The 'H' point of the driver and passenger test dummies must coincide, within 13 mm in the vertical dimension and 13 mm in the horizontal dimension, with a point 6 mm below the position of the 'H' point of the machine, except that the length of the thigh and lower leg segments used to calculate the 'H' point must be adjusted to 414 and 401 mm, instead of 432 and 417 mm respectively.

2.4.3.2. Pelvic angle

As determined using the pelvic angle gauges⁽¹⁾ inserted into the 'H' point gauging hole of the dummy, the angle measured from the horizontal on the 76,2 mm flat surface of the gauge must be $22,5^\circ \pm 2,5^\circ$.

2.5. **Legs**

2.5.1. The upper legs of the driver and passenger test dummies must rest against the seat cushion to the extent permitted by placement of the feet. The initial distance between the outboard knee clevis flange surfaces must be $270 \text{ mm} \pm 10 \text{ mm}$.

2.5.2. To the extent practicable, the left leg of the driver dummy and both legs of the passenger dummy must be in vertical longitudinal planes. To the extent practicable, the right leg of the driver dummy must be in a vertical plane. Final adjustment to accommodate placement of feet in accordance with 2.6 for various passenger compartment configurations is permitted.

2.6. **Feet**

2.6.1. The right foot of the driver test dummy must rest on the undepressed accelerator with the rearmost point of the heel on the floor surface in the plane of the pedal. If the foot cannot be placed on the accelerator pedal, it must be positioned perpendicular to the tibia and placed as far forward as possible in the direction of the centreline of the pedal with the rearmost point of the heel resting on the floor surface. The heel of the left foot must be placed as far forward as possible and must rest on the floor. The left foot must be positioned as flat as possible on the toeboard. The longitudinal centreline of the left foot must be placed as parallel as possible to the longitudinal centreline of the vehicle.

2.6.2. The heels of both feet of the passenger test dummy must be placed as far forward as possible and must rest on the floor. Both feet must be positioned as flat as possible on the toeboard. The longitudinal centreline of the feet must be placed as parallel as possible to the longitudinal centreline of the vehicle.

2.7. The measuring instruments installed must not in any way affect the movement of the dummy during impact.

2.8. The temperature of the dummies and the system of measuring instruments must be stabilized before the test and maintained so far as possible within a range between 19 °C and 22 °C.

2.9. **Dummy clothing**

2.9.1. The instrumented dummies will be clothed in formfitting cotton stretch garments with short sleeves and mid-calf length trousers specified in FMVSS 208, drawings 78051-292 and 293 or their equivalent.

2.9.2. A size 11EE shoe, specified in FMVSS 208, drawings 78051-294 (left) and 78051-295 (right) or their equivalent, will be placed on each foot of the test dummies.

3. **ADJUSTMENT OF RESTRAINT SYSTEM**

With the test dummy at its designated seating position as specified by the appropriate requirements of paragraphs 2.1 to 2.6, place the belt around the test dummy and fasten the latch. Remove all slack from the lap belt. Pull the upper torso webbing out of the retractor and allow it to retract; repeat this operation four times. Apply a tension load of between 9 and 18 N to the lap belt. If the belt system is equipped with a tension-relieving device, introduce the maximum amount of slack into the upper torso belt that is

⁽¹⁾ Until an international standard has been adopted for this item, gauges conforming to GM drawing 78051-532, referencing part 572, must be used.

▼B

recommended by the manufacturer for normal use in the owner's manual for the vehicle. If the belt system is not equipped with a tension-relieving device, allow the excess webbing in the shoulder belt to be retracted by the retracting force of the retractor.



Appendix 4

TEST PROCEDURE WITH TROLLEY

1. TEST INSTALLATION AND PROCEDURE
 - 1.1. **Trolley**

The trolley must be so constructed that no permanent deformation appears after the test. It must be so guided that, during the impact phase, the deviation does not exceed 5° in the vertical plane and 2° in the horizontal plane.
 - 1.2. **State of the structure**
 - 1.2.1. *General*

The structure tested must be representative of the series production of the vehicles concerned. Some components may be replaced or removed where such replacement or removal clearly has no effect on the test results.
 - 1.2.2. *Adjustments*

Adjustments must conform to those set out in paragraph 1.4.3 of Appendix 1 to this Annex, taking into account what is stated in paragraph 1.2.1 above.
 - 1.3. **Attachment of the structure**
 - 1.3.1. The structure must be firmly attached to the trolley in such a way that no relative displacement occurs during the test.
 - 1.3.2. The method used to fasten the structure to the trolley must not have the effect of strengthening the seat anchorages or restraint devices, or of producing any abnormal deformation of the structure.
 - 1.3.3. The attachment device recommended is that whereby the structure rests on supports placed approximately in the axis of the wheels or, if possible, whereby the structure is secured to the trolley by the fastenings of the suspension system.
 - 1.3.4. The angle between the longitudinal axis of the vehicle and the direction of motion of the trolley must be $0^\circ \pm 2^\circ$.
 - 1.4. **Dummies**

The dummies and their positioning must conform to the specifications in paragraph 2 of Appendix 3.
 - 1.5. **Measuring apparatus**
 - 1.5.1. *Deceleration of the structure*

The position of the transducers measuring the deceleration of the structure during the impact must be parallel to the longitudinal axis of the trolley according to the specifications of Appendix 5 (CFC 180).
 - 1.5.2. *Measurements to be made on the dummies*

All the measurements necessary for checking the listed criteria are set out in paragraph 5 of Appendix 1.
 - 1.6. **Deceleration curve of the structure**

The deceleration curve of the structure during the impact phase shall be such that the 'variation of speed in relation to time' curve obtained by integration at no point differs by more than ± 1 m/s from the 'variation of speed in relation to time' reference curve of the vehicle concerned as defined in Figure 1 of this Appendix. A displacement with regard to the time axis of the reference curve may be used to obtain the structure velocity inside the corridor.
 - 1.7. **Reference curve $\Delta V = f(t)$ of the vehicle concerned**

This reference curve is obtained by integration of the deceleration curve of the vehicle concerned measured in the frontal impact test against a barrier as provided for in paragraph 6 of Appendix 1 to this Annex.
 - 1.8. **Equivalent method**

The test may be performed by some other method than that of deceleration of a trolley, provided that such method complies with the requirement concerning the range of variation of speed described in paragraph 1.6.

▼B

Figure 1
Equivalence curve — tolerance band for curve $V = f(t)$

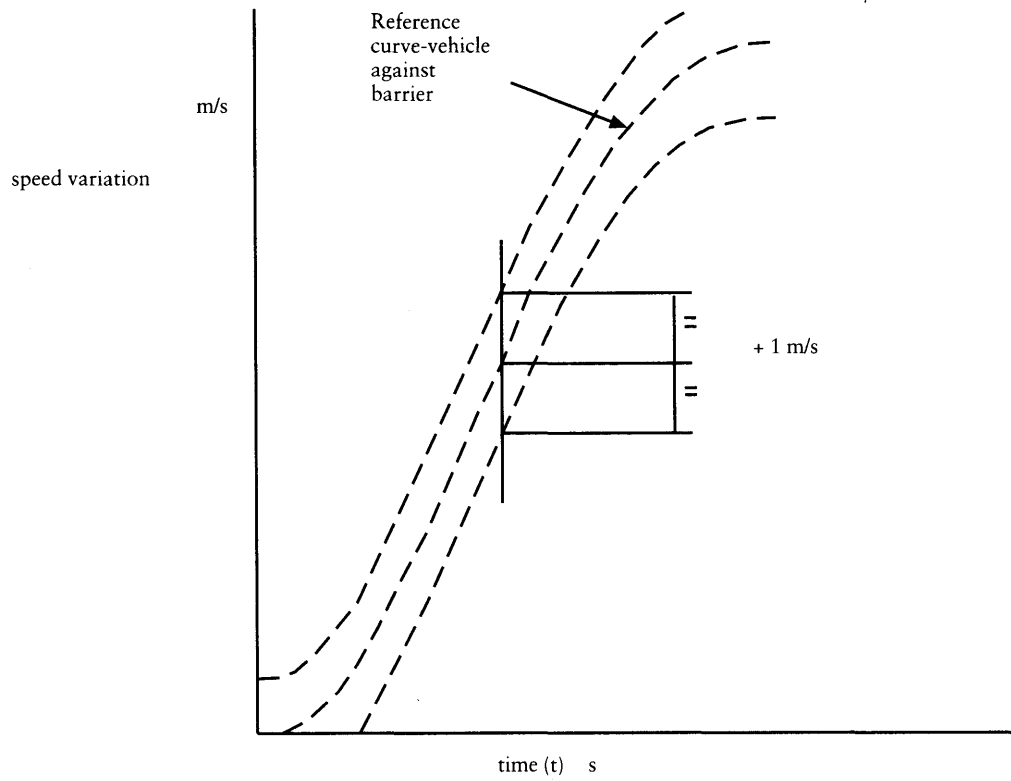



Appendix 5

TECHNIQUE OF MEASUREMENT IN MEASUREMENT TESTS: INSTRUMENTATION

1. DEFINITIONS

1.1. **Data channel**

A data channel comprises all the instrumentation from a transducer (or multiple transducers whose outputs are combined in some specified way) up to and including any analysis procedures that may alter the frequency content or the amplitude content of data.

1.2. **Transducer**

The first device in a data channel used to convert a physical quantity to be measured into a second quantity (such as an electrical voltage) which can be processed by the remainder of the channel.

1.3. **Channel amplitude class: CAC**

The designation for a data channel that meets certain amplitude characteristics as specified in this Appendix. The CAC number is numerically equal to the upper limit of the measurement range.

1.4. **Characteristic frequencies F_H , F_L , F_N**

These frequencies are defined in figure 1.

1.5. **Channel frequency class: CFC**

The channel frequency class is designated by a number indicating that the channel frequency response lies within the limits specified in Figure 1. This number and the value of the frequency F_H in Hz are numerically equal.

1.6. **Sensitivity coefficient**

The slope of the straight line representing the best fit to the calibration values determined by the method of least square within the channel amplitude class.

1.7. **Calibration factor of a data channel**

The mean value of the sensitivity coefficients evaluated over frequencies which are evenly spaced on a logarithmic scale between F_L and $0,4 F_H$.

1.8. **Linearity error**

The ratio, in per cent, of the maximum difference between the calibration value and the corresponding value read on the straight line defined in 1.6 at the upper limit of the channel amplitude class.

1.9. **Cross sensitivity**

The ratio of the output signal to the input signal, when an excitation is applied to the transducer perpendicular to the measurement axis. It is expressed as a percentage of the sensitivity along the measurement axis.

1.10. **Phase delay time**

The phase delay time of a data channel is equal to the phase delay (in radians) of a sinusoidal signal, divided by the angular frequency of that signal (in radians/s).

1.11. **Environment**

The aggregate, at a given moment, of all external conditions and influences to which the data channel is subjected.

2. PERFORMANCE REQUIREMENTS

2.1. **Linearity error**

The absolute value of the linearity error of a data channel at any frequency in the CFC, must be equal to or less than 2,5 % of the value of the CAC, over the whole measurement range.

2.2. **Amplitude against frequency**

The frequency response of a data channel must lie within the limiting curves given in Figure 1. The zero dB line is determined by the calibration factor.

▼**B****2.3. Phase delay time**

The phase delay time between the input and the output signals of a data channel must be determined and must not vary by more than $0,1 F_H$ s between $0,03 F_H$ and F_H .

2.4. Time base

2.4.1. A time base must be recorded and must at least give 10 ms with an accuracy of 1 %.

2.4.2. *Relative time delay*

The relative time delay between the signal of two or more data channels, regardless of their frequency class, must not exceed 1 ms excluding delay caused by phase shift.

Two or more data channels of which the signals are combined must have the same frequency class and must not have relative time delay greater than $0,1 F_{HS}$.

This requirement applies to analogue signals as well as to synchronization pulses and digital signals.

2.5. Transducer cross sensitivity

The transducer cross sensitivity must be less than 5 % in any direction.

2.6. Calibration2.6.1. *General*

A data channel should be calibrated at least once a year against reference equipment traceable to known standards. The methods used to carry out a comparison with reference equipment must not introduce an error greater than 1 % of the CAC. The use of the reference equipment is limited to the frequency range for which it has been calibrated. Subsystems of a data channel may be evaluated individually and the results factored into the accuracy of the total data channel. This can be done for example by an electrical signal of known amplitude simulating the output signal of the transducer which allows a check to be made on the gain factor of the data channel, excluding the transducer.

2.6.2. *Accuracy of reference equipment for calibration*

The accuracy of the reference equipment must be certified or endorsed by an official metrology service.

2.6.2.1. **Static calibration**2.6.2.1.1. **Accelerations**

The errors must be less than $\pm 1,5$ % of the CAC.

2.6.2.1.2. **Forces**

The errors must be less than ± 1 % of the CAC.

2.6.2.1.3. **Displacements**

The errors must be less than ± 1 % of the CAC.

2.6.2.2. **Dynamic calibration**2.6.2.2.1. **Accelerations**

The error in the reference accelerations expressed as a percentage of the CAC must be less than $\pm 1,5$ % below 400 Hz, less than ± 2 % between 400 Hz and 900 Hz, and less than $\pm 2,5$ % above 900 Hz.

2.6.2.3. **Time**

The relative error in the reference time must be less than 10^{-5} .

2.6.3. *Sensitivity coefficient and linearity error*

The sensitivity coefficient and the linearity error must be determined by measuring the output signal of the data channel against a known input signal for various values of this signal. The calibration of the data channel must cover the whole range of the amplitude class.

For bi-directional channels, both the positive and negative values must be used.

If the calibration equipment cannot produce the required input owing to the excessively high values of the quantity to be measured, calibrations must be carried out within the limits of the calibration standards and these limits must be recorded in the test report.

▼B

A total data channel must be calibrated at a frequency or at a spectrum of frequencies having a significant value between F_L and $0,4 F_H$.

2.6.4. *Calibration of the frequency response*

The response curves of phase and amplitude against frequency are determined by measuring the output signals of the data channel in terms of phase and amplitude against a known input signal, for various values of this signal varying between F_L and 10 times the CFC or 3 000 Hz, whichever is lower.

2.7. **Environmental effects**

A regular check should be made to identify any environmental influence (such as electric or magnetic flux, cable velocity, etc.). This can be done for instance by recording the output of spare channels equipped with dummy transducers. If significant output signals are obtained corrective action should be taken, for instance by replacement of cables.

2.8. **Choice and designation of the data channel**

The CAC and CFC define a data channel.

The CAC must be 1, 2 or 5 to a power of ten.

3. MOUNTING OF TRANSDUCERS

Transducers should be rigidly secured so that their recordings are affected by vibration as little as possible. Any mounting having a lowest resonance frequency equal to at least 5 times the frequency F_H of the data channel considered will be considered valid. Acceleration transducers in particular should be mounted in such a way that the initial angle of the real measurement axis to the corresponding axis of the reference axis system is not greater than 5° unless an analytical or experimental assessment of the effect of the mounting on the collected data is made. When multi-axial accelerations at a point are to be measured, each acceleration transducer axis should pass within 10 mm of that point, and the centre of seismic mass of each accelerometer should be within 30 mm of that point.

4. RECORDING

4.1. **Analogue magnetic recorder**

Tape speed should be stable to within not more than 0,5 % of the tape speed used. The signal-to-noise ratio of the recorder should not be less than 42 dB at the maximum tape speed. The total harmonic distortion should be less than 3 % and the linearity error should be less than 1 % of the measurement range.

4.2. **Digital magnetic recorder**

Tape speed should be stable to within not more than 10 % of the tape speed used.

4.3. **Paper tape recorder**

In case of direct data recording the paper speed in mm/s should be at least one and a half times the number expressing F_H in Hz. In other cases the paper speed should be such that equivalent resolution is obtained.

5. DATA PROCESSING

5.1. **Filtering**

Filtering corresponding to the frequencies of the data channel class may be carried out during either recording or processing of data. However, before recording, analogical filtering at a higher level than CFC should be effected in order to use at least 50 % of the dynamic range of the recorder and to reduce the risk of high frequencies saturating the recorder or causing aliasing errors in the digitalizing process.

5.2. **Digitalizing**

5.2.1. The sampling frequency should be equal to at least $8 F_H$. In the case of analogue recording, when the recording and reading speeds are different, the sampling frequency can be divided by the speed ratio.

5.2.2. *Amplitude resolution*

The size of digital words should be at least 7 bits and a parity bit.

▼B

6. PRESENTATION OF RESULTS

The results should be presented on A4 size paper (210 × 297 mm). Results presented as diagrams should have axes scaled with a measurement unit corresponding to a suitable multiple of the chosen unit (for example, 1, 2, 5, 10, 20 mm). SI units should be used, except for vehicle velocity, where km/h may be used, and for accelerations due to impact where g , with $g = 9,81 \text{ m/s}^2$, may be used.

Figure 1
Frequency response curve

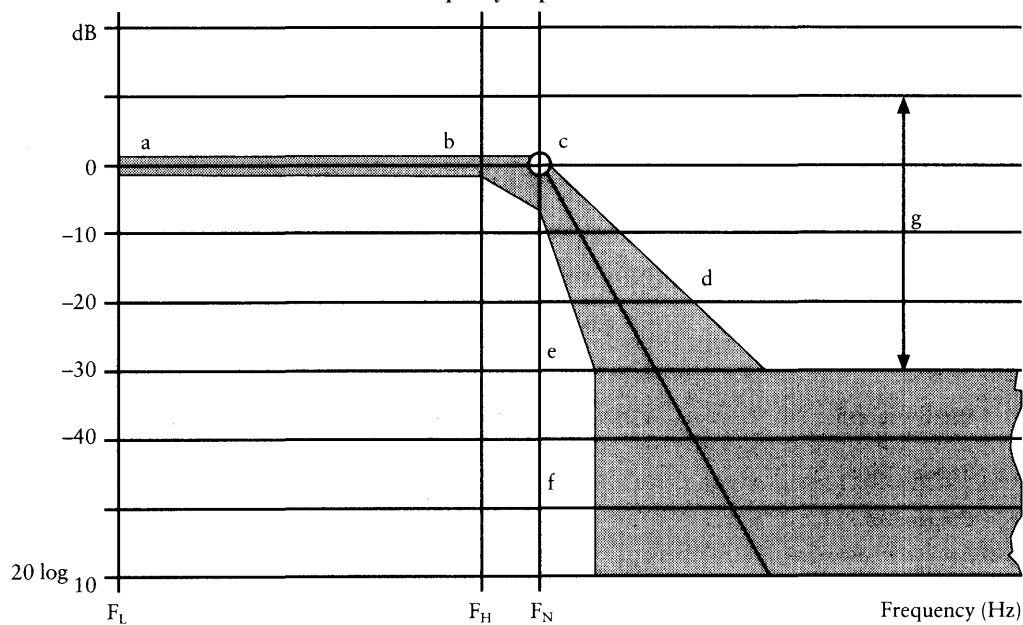



Appendix 6

DEFINITION OF THE DEFORMABLE BARRIER

1. COMPONENT AND MATERIAL SPECIFICATIONS

The dimensions of the barrier are illustrated in Figure 1 of this Appendix. The dimensions of the individual components of the barrier are listed separately below.

1.1. **Main honeycomb block**

| | |
|-------------------|---|
| <i>Dimensions</i> | All dimensions should allow a tolerance of $\pm 2,5$ mm |
| Height: | 650 mm (in direction of honeycomb ribbon axis) |
| Width: | 1 000 mm |
| Depth: | 450 mm (in direction of honeycomb cell axes) |
| <i>Material</i> | Aluminium 3003 (ISO 209, part 1) |
| Foil thickness: | 0,076 mm |
| Cell size: | 19,14 mm |
| Density: | 28,6 kg/m ³ |
| Crush strength: | 0,342 MPa + 0 % - 10 % ⁽¹⁾ _2" |

1.2. **Bumper element**

| | |
|-------------------|---|
| <i>Dimensions</i> | All dimensions should allow a tolerance of $\pm 2,5$ mm |
| Height: | 330 mm (in direction of honeycomb ribbon axis) |
| Width: | 1 000 mm |
| Depth: | 90 mm (in direction of honeycomb cell axes) |
| <i>Material</i> | Aluminium 3003 (ISO 209, part 1) |
| Foil thickness: | 0,076 mm |
| Cell size: | 6,4 mm |
| Density: | 82,6 kg/m ³ |
| Crush strength: | 1,711 MPa + 0 % - 10 % ⁽¹⁾ _2" |

1.3. **Backing sheet**

| | |
|-------------------|------------------------|
| <i>Dimensions</i> | |
| Height: | 800 mm $\pm 2,5$ mm |
| Width: | 1 000 mm $\pm 2,5$ mm |
| Thickness: | 2,0 mm $\pm 0,1$ mm_2" |

1.4. **Cladding sheet**

| | |
|-------------------|--|
| <i>Dimensions</i> | |
| Length: | 1 700 mm $\pm 2,5$ mm |
| Width: | 1 000 mm $\pm 2,5$ mm |
| Thickness: | 0,81 mm $\pm 0,07$ mm |
| <i>Material:</i> | Aluminium 5251/5052 (ISO 209, part 1)_2" |

1.5. **Bumper facing sheet**

| | |
|-------------------|---------------------|
| <i>Dimensions</i> | |
| Height: | 330 mm $\pm 2,5$ mm |

▼B

| | |
|------------|--|
| Width: | 1 000 mm ± 2,5 mm |
| Thickness: | 0,81 mm ± 0,07 mm |
| Material: | Aluminium 5251/5052 (ISO 209, part 1)_2" |

1.6. Adhesive

The adhesive to be used throughout should be a two-part polyurethane (such as Ciba-Geigy XB5090/1 resin with XB5304 hardener, or equivalent).

(¹) In accordance with the certification procedure described in paragraph 2.

2. ALUMINIUM HONEYCOMB CERTIFICATION

A complete testing procedure for certification of aluminium honeycomb is given in NHTSA TP-214D. The following is a summary of the procedure that should be applied to materials for the frontal impact barrier, these materials having a crush strength of 0,342 MPa and 1,711 MPa respectively.

2.1. Sample locations

To ensure uniformity of crush strength across the whole of the barrier face, eight samples must be taken from four locations evenly spaced across the honeycomb block. For a block to pass certification, seven of these eight samples must meet the crush strength requirements of the following sections.

The location of the samples depends on the size of the honeycomb block. First, four samples, each measuring 300 mm × 300 mm × 50 mm thick must be cut from the block of barrier face material. Please refer to Figure 2 for an illustration of how to locate these sections within the honeycomb block. Each of these larger samples must be cut into samples for certification testing (150 mm × 150 mm × 50 mm). Certification must be based on the testing of two samples from each of these four locations. The other two should be made available to the applicant, upon request.

2.2. Sample size

Samples of the following size must be used for testing:

Length: 150 mm ± 6 mm

Width: 150 mm ± 6 mm

Thickness: 50 mm ± 2 mm

The walls of incomplete cells around the edge of the sample must be trimmed as follows:

in the 'W' direction, the fringes must be no greater than 1,8 mm (see Figure 3),

in the 'L' direction, half the length of one bonded cell wall (in the ribbon direction) must be left at either end of the specimen (see Figure 3).

2.3. Area measurement

The length of the sample must be measured in three locations, 12,7 mm from each end and in the middle, and recorded as L1, L2 and L3 (Figure 3). In the same manner, the width must be measured and recorded as W1, W2 and W3 (Figure 3). These measurements must be taken on the centreline of the thickness. The crush area must then be calculated as:

$$A = \frac{(L1 + L2 + L3)}{3} \times \frac{(W1 + W2 + W3)}{3}$$

2.4. Crush rate and distance

The sample must be crushed at a rate of not less than 5,1 mm/min and not more than 7,6 mm/min. The minimum crush distance is 16,5 mm.

2.5. Data collection

Force versus deflection data are to be collected in either analogue or digital form for each sample tested. If analogue data are collected then a means of converting this to digital must be available. All digital data must be collected at a rate of no less than 5 Hz (5 points per second).

▼B**2.6. Crush strength determination**

Ignore all data prior to 6,4 mm of crush and after 16,5 mm of crush. Divide the remaining data into three sections or displacement intervals ($n = 1,2,3$) (see Figure 4) as follows:

- (1) 06,4-09,7 mm inclusive,
- (2) 09,7-13,2 mm exclusive,
- (3) 13,2-16,5 mm inclusive.

Find the average for each section as follows:

$$F(n) = \frac{[F(n)1 + F(n)2 + \dots + F(n)m]}{m}; m = 1, 2, 3$$

where m represents the number of data points measured in each of the three intervals. Calculate the crush strength of each section as follows:

$$S(n) = \frac{F(n)}{A}; n = 1, 2, 3$$

2.7. Sample crush strength specification

For a honeycomb sample to pass this certification, the following condition must be met:

$$0,308 \text{ MPa} \leq S(n) \leq 0,342 \text{ MPa for } 0,342 \text{ MPa material}$$

$$1,540 \text{ MPa} \leq S(n) \leq 1,711 \text{ MPa for } 1,711 \text{ MPa material } n = 1,2,3.$$

2.8. Block crush strength specification

Eight samples are to be tested from four locations, evenly spaced across the block. For a block to pass certification, seven of the eight samples must meet the crush strength specification of the previous section.

3. ADHESIVE BONDING PROCEDURE

- 3.1. Immediately before bonding, aluminium sheet surfaces to be bonded must be thoroughly cleaned using a suitable solvent, such as 1-1-1 Trichloroethane. This is to be carried out at least twice or as required to eliminate grease or dirt deposits. The cleaned surfaces must then be abraded using 120 grit abrasive paper. Metallic/silicon carbide abrasive paper is not to be used. The surfaces must be thoroughly abraded and the abrasive paper changed regularly during the process to avoid clogging, which may lead to a polishing effect. Following abrading, the surfaces must be thoroughly cleaned again, as above. In total, the surfaces must be solvent cleaned at least four times. All dust and deposits left as a result of the abrading process must be removed, as these will adversely affect bonding.
- 3.2. The adhesive should be applied to one surface only, using a ribbed rubber roller. In cases where honeycomb is to be bonded to aluminium sheet, the adhesive should be applied to the aluminium sheet only. A maximum of 0,5 kg/m² must be applied evenly over the surface, giving a maximum film thickness of 0,5 mm.

4. CONSTRUCTION

- 4.1. The main honeycomb block must be bonded to the backing sheet with adhesive such that the cell axes are perpendicular to the sheet. The cladding must be bonded to the front surface of the honeycomb block. The top and bottom surfaces of the cladding sheet must not be bonded to the main honeycomb block but should be positioned closely to it. The cladding sheet must be adhesively bonded to the backing sheet at the mounting flanges.
- 4.2. The bumper element must be adhesively bonded to the front of the cladding sheet such that the cell axes are perpendicular to the sheet. The bottom of the bumper element must be flush with the bottom surface of the cladding sheet. The bumper facing sheet must be adhesively bonded to the front of the bumper element.
- 4.3. The bumper element must then be divided into three equal sections by means of two horizontal slots. These slots must be cut through the entire depth of the bumper section and extend the whole width of the bumper. The slots must be cut using a saw; their width must be the width of the blade used and must not exceed 4,0 mm.
- 4.4. Clearance holes for mounting the barrier are to be drilled in the mounting flanges (shown in Figure 5). The holes must be of 9,5 mm diameter. Five holes must be drilled in the top flange at a distance of 40 mm from the top edge of the flange and five in the bottom flange, 40 mm from the bottom edge of that flange. The holes must be at 100 mm, 300 mm, 500 mm,

▼B

700 mm, 900 mm from either edge of the barrier. All holes must be drilled to ± 1 mm of the nominal distances.

5. MOUNTING

- 5.1. The deformable barrier must be rigidly fixed to the edge of a mass of not less than 7×10^4 kg or to some structure attached thereto. The attachment of the barrier face must be such that the vehicle must not contact any part of the structure more than 75 mm from the top surface of the barrier (excluding the upper flange) during any stage of the impact⁽¹⁾. The front face of the surface to which the deformable barrier is attached must be flat and continuous over the height and width of the face and must be vertical $\pm 1^\circ$ and perpendicular $\pm 1^\circ$ to the axis of the run-up track. The attachment surface must not be displaced by more than 10 mm during the test. If necessary, additional anchorage or arresting devices must be used to prevent displacement of the concrete block. The edge of the deformable barrier must be aligned with the edge of the concrete block appropriate for the side of the vehicle to be tested.
- 5.2. The deformable barrier must be fixed to the concrete block by means of ten bolts, five in the top mounting flange and five in the bottom. These bolts must be of at least 8 mm diameter. Steel clamping strips must be used for both the top and bottom mounting flanges (see Figures 1 and 5). These strips must be 60 mm high and 1 000 mm wide and have a thickness of at least 3 mm. Five clearance holes of 9,5 mm diameter must be drilled in both strips to correspond with those in the mounting flange on the barrier (see paragraph 4). None of the fixtures must fail in the impact test.

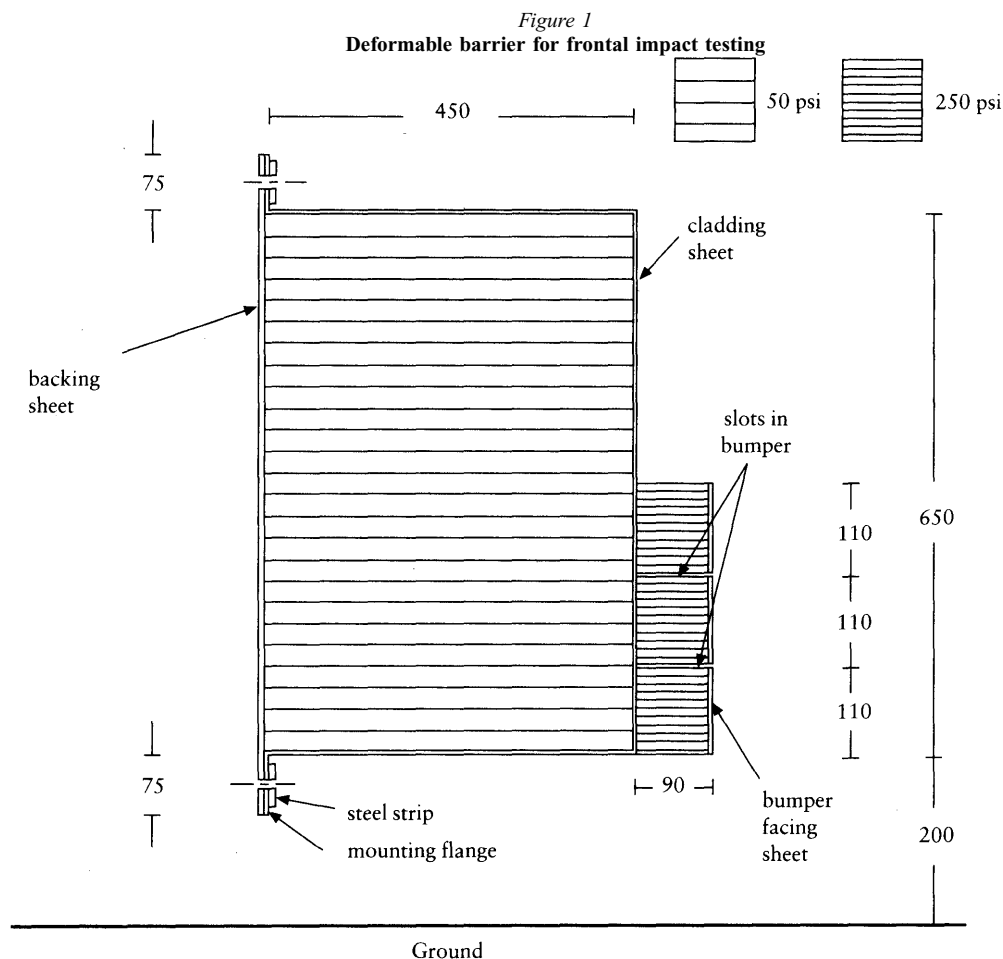

Barrier width = 1 000 mm.
All dimensions in mm.

⁽¹⁾ A mass, the end of which is between 925 mm and 1 000 mm high and at least 1 000 mm deep, is considered to satisfy this requirement.

▼B

Figure 2
Locations of samples for certification

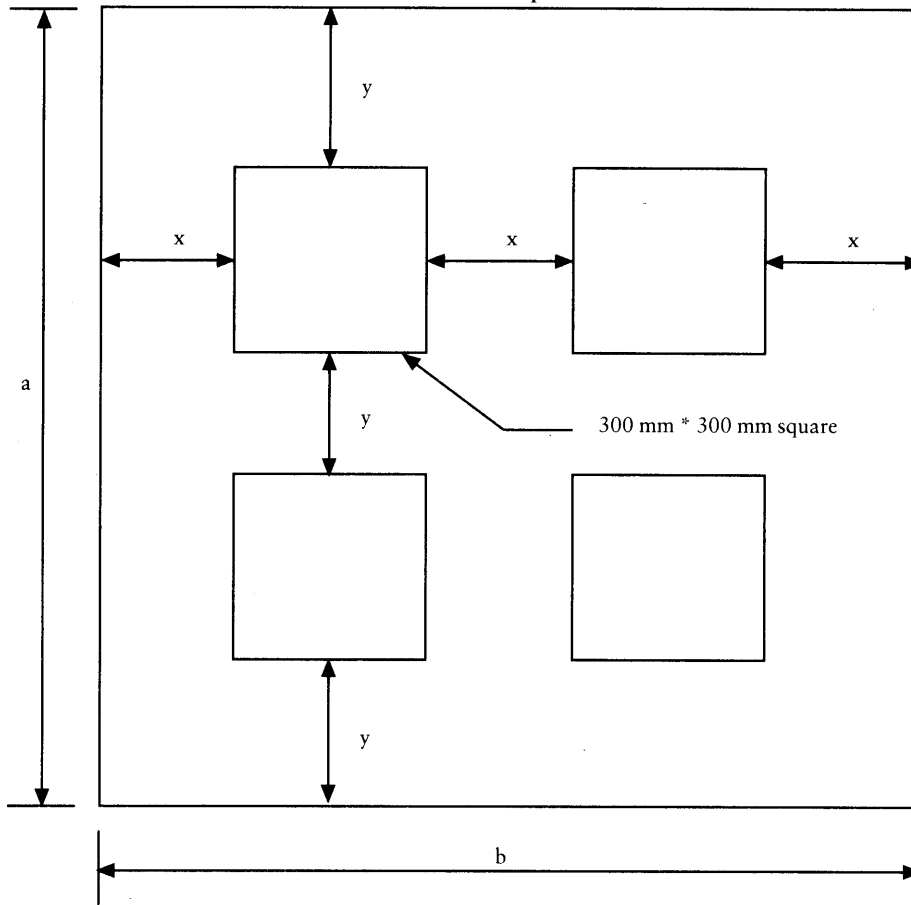

If $a \geq 900$ mm: $x = \frac{1}{3}(b - 600$ mm) and $y = \frac{1}{3}(a - 600$ mm) (for $a \leq b$)

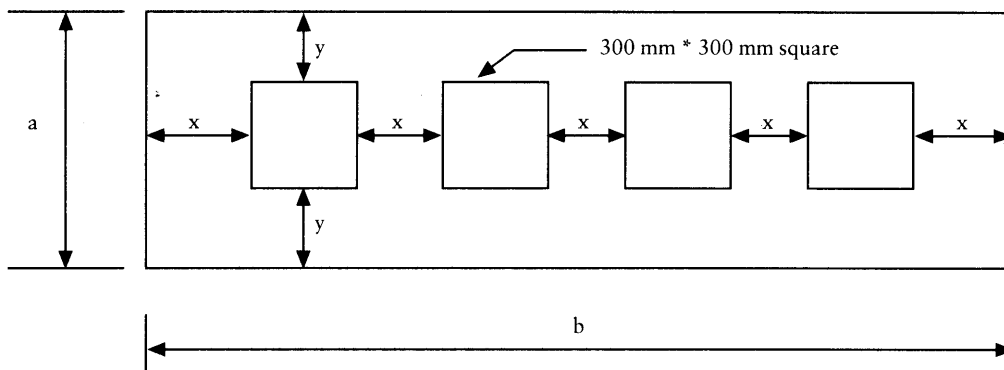

If $a < 900$ mm: $x = \frac{1}{3}(b - 1\ 200$ mm) and $y = \frac{1}{2}(a - 300$ mm) (for $a \leq b$)

▼B

Figure 3
Honeycomb axes and measured dimensions

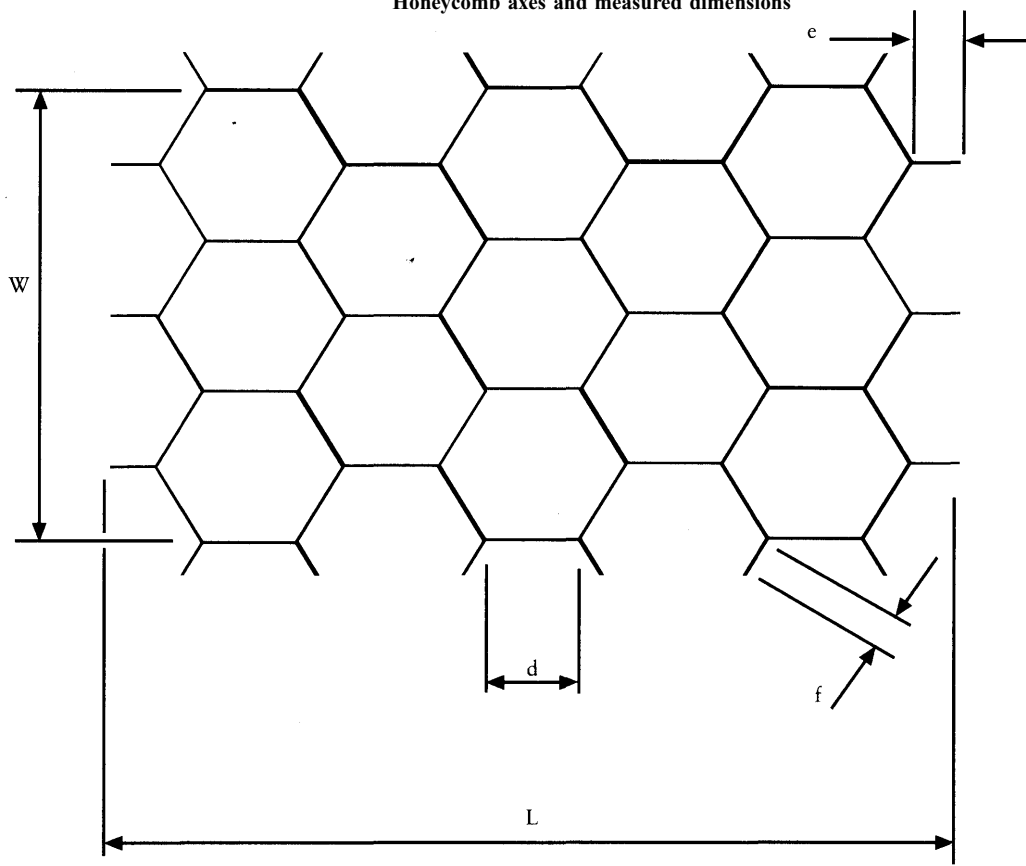

$$e = d/2$$

$$f = 0,8 \text{ mm}$$

▼B

Figure 4
Crush force and displacement

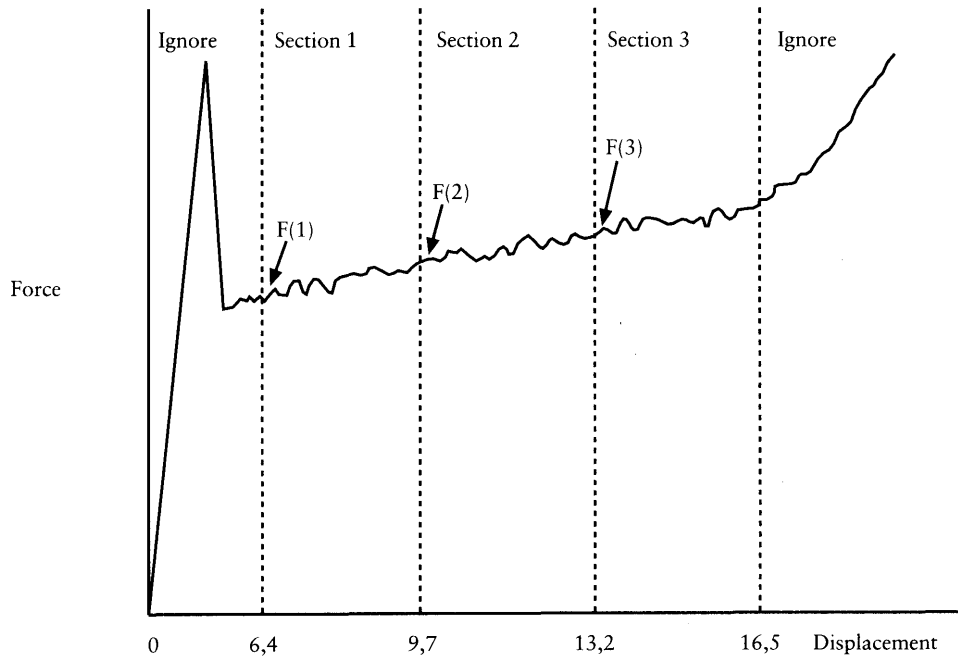
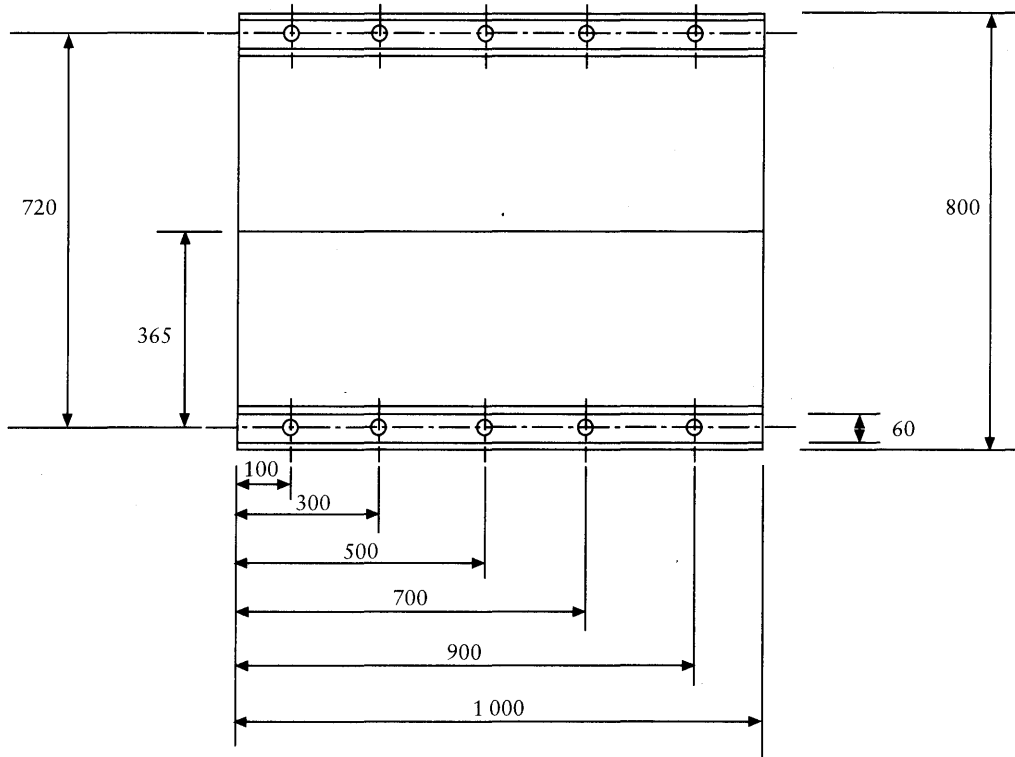

Figure 5
Positions of holes for barrier mounting



Hole diameters 9,5 mm.
All dimensions in mm.



Appendix 7

CERTIFICATION PROCEDURE FOR THE DUMMY LOWER LEG AND FOOT

1. TIBIA IMPACT TEST

1.1. The objective of this test is to measure the response of Hybrid III tibia skin and insert to well-defined, hard-faced pendulum impacts.

1.2. Left and right Hybrid III leg assemblies, from the knee clevis joint down, shall be used. Each shall be attached rigidly to the test fixture.

1.3. **Test procedure**

1.3.1. Each leg assembly shall be maintained (soaked) for 4 hours prior to the test at a temperature of 22 ± 3 °C and a relative humidity of 40 ± 30 %. The soak period shall not include the time required to reach steady state conditions.

1.3.2. Align the impactor accelerometer with its sensitive axis parallel to the impactor longitudinal centre line.

1.3.3. Clean the impact surface of the skin and also the impactor face with isopropyl alcohol or equivalent prior to the test.

1.3.4. Mount the leg assembly to the fixture at the knee clevis joint, as shown in Figure 1. The test fixture shall be rigidly secured to prevent movement during impact. The test fixture shall be constructed such that there is no contact with any part of the leg assembly, other than at the fixing point, during the test. The line between the knee clevis joint and the centre of the ankle joint shall be vertical $\pm 5^\circ$. Adjust the knee and ankle joint to $1,5 \pm 0,5$ g range before each test.

1.3.5. The rigid impactor shall have a mass of $5,0 \pm 0,2$ kg including instrumentation. The impact face shall be a half cylinder with its principal axis horizontal $\pm 1^\circ$ and perpendicular to the direction of impact. The radius of the impact surface shall be 40 ± 2 mm and the width of the impact surface shall be at least 80 mm. The impactor shall strike the tibia at a point midway between the knee clevis joint and the ankle pivot along the centre line to the tibia. The impactor shall strike the tibia so that the horizontal centre line of the impactor falls within $0,5^\circ$ of a horizontal line parallel to the femur load cell simulator at time-zero. The impactor shall be guided to exclude significant lateral, vertical or rotational movement at time-zero.

1.3.6. Allow a period of at least 30 minutes between successive tests on the same leg.

1.3.7. The data acquisition system, including transducers, shall conform to the specifications for CFC 600, as described in Appendix 5 to this Annex.

1.4. **Performance specification**

1.4.1. When each tibia is impacted at $2,1 \pm 0,3$ m/s in accordance with paragraph 1.3, the impact force, which is the product of the pendulum mass and the deceleration, shall be $2,3 \pm 0,3$ kN.

2. UPPER FOOT IMPACT TEST

2.1. The objective of this test is to measure the response of the Hybrid III foot and ankle to well-defined, hard-faced pendulum impacts.

2.2. The complete Hybrid III lower leg assembly, left (86-5001-001) and right (86-5001-002), equipped with the foot and ankle assembly, left (78051-614) and right (78051-615), shall be used, including the knee assembly. The load cell simulator (78051-319 Rev A) shall be used to secure the knee-cap assembly (78051-16 Rev B) to the test fixture.

2.3. **Test procedure**

2.3.1. Each leg assembly shall be maintained (soaked) for 4 hours prior to the test at a temperature of 22 ± 3 °C and a relative humidity of 40 ± 30 %. The soak period shall not include the time required to reach steady state conditions.

2.3.2. Clean the impact surface of the skin and also the impactor face with isopropyl alcohol or equivalent prior to the test.

2.3.2a. Align the impactor accelerometer with its sensitive axis parallel to the direction of impact at contact with the foot.

2.3.3. Mount the leg assembly to the fixture shown in Figure 1a. The test fixture shall be secured rigidly to prevent movement during the impact test. The centre line of the femur load cell simulator (78051-319) shall be vertical

▼B

$\pm 0,5^\circ$. Adjust the mount such that the line joining the knee clevis joint and the ankle attachment bolt is horizontal $\pm 3^\circ$ with the heel resting on two sheets of low-friction (PTFE) material. Ensure that the tibia flesh is located towards the knee end of the tibia. Adjust the ankle such that the plane of the underside of the foot is vertical $\pm 3^\circ$. Adjust the knee and ankle joint to $1,5 \pm 0,5$ g range before each test.

2.3.4. The rigid impactor comprises a horizontal cylinder diameter 50 ± 2 mm and a pendulum support arm diameter 19 ± 1 mm (Figure 3a). The cylinder has a mass of $1,25 \pm 0,02$ kg including instrumentation and any part of the support arm within the cylinder. The pendulum arm has a mass of 285 ± 5 g. The mass of any rotating part of the axle to which the support arm is attached should not be greater than 100 g. The length between the central horizontal axis of the impactor cylinder and the axis of rotation of the whole pendulum shall be $1\,250 \pm 1$ mm. The impact cylinder is mounted with its longitudinal axis horizontal and perpendicular to the direction of impact. The pendulum shall impact the underside of the foot, at a distance of 185 ± 2 mm from the base of the heel resting on the rigid horizontal platform, so that the longitudinal centre line of the pendulum arm falls within 1° of a vertical line at impact. The impactor shall be guided to exclude significant lateral, vertical or rotational movement at time-zero.

2.3.5. Allow a period of at least 30 minutes between successive tests on the same leg.

2.3.6. The data acquisition system, including transducers, shall conform to the specifications for CFC 600, as described in Appendix 5 to this Annex.

2.4. Performance specification

2.4.1. When the ball of each foot is impacted at $6,7 \pm 0,2$ m/s in accordance with paragraph 2.3, the maximum tibia bending moment about the y-axis (M_y) shall be between 100 Nm and 140 Nm.

3. LOWER FOOT IMPACT TEST

3.1. The objective of this test is to measure the response of the Hybrid III foot skin and insert to well-defined, hard-faced pendulum impacts.

3.2. The complete Hybrid III lower leg assembly, left (86-5001-001) and right (86-5001-002), equipped with the foot and ankle assembly, left (78051-614) and right (78051-615), shall be used, including the knee assembly. The load cell simulator (78051-319 Rev A) shall be used to secure the knee-cap assembly (78051-16 Rev B) to the test fixture.

3.3. Test procedure

3.3.1. Each leg assembly shall be maintained (soaked) for 4 hours prior to the test at a temperature of 22 ± 3 °C and a relative humidity of 40 ± 30 %. The soak period shall not include the time required to reach steady state conditions.

3.3.2. Align the impactor accelerometer with its sensitive axis parallel to the impactor longitudinal centre line.

3.3.3. Clean the impact surface of the skin and also the impactor face with isopropyl alcohol or equivalent prior to the test.

3.3.4. Mount the leg assembly to the fixture shown in Figure 1b. The test fixture shall be secured rigidly to prevent movement during the impact test. The centre line of the femur load cell simulator (78051-319) shall be vertical $\pm 0,5^\circ$. Adjust the mount such that the line joining the knee clevis joint and the ankle attachment bolt is horizontal $\pm 3^\circ$ with the heel resting on two sheets of low-friction (PTFE) material. Ensure that the tibia flesh is located towards the knee end of the tibia. Adjust the ankle such that the plane of the underside of the foot is vertical $\pm 3^\circ$. Adjust the knee and ankle joint to $1,5 \pm 0,5$ g range before each test.

3.3.5. The rigid impactor comprises a horizontal cylinder diameter 50 ± 2 mm and a pendulum support arm diameter 19 ± 1 mm (Figure 3a). The cylinder has a mass of $1,25 \pm 0,02$ kg including instrumentation and any part of the support arm within the cylinder. The pendulum arm has a mass of 285 ± 5 g. The mass of any rotating part of the axle to which the support arm is attached should not be greater than 100 g. The length between the central horizontal axis of the impactor cylinder and the axis of rotation of the whole pendulum shall be $1\,250 \pm 1$ mm. The impact cylinder is mounted with its longitudinal axis horizontal and perpendicular to the direction of impact. The pendulum shall impact the underside of the foot, at a distance of 62 ± 2 mm from the base of the heel resting on the rigid horizontal platform, so that the longitudinal centre line of the pendulum arm falls within 1° of a vertical line at impact. The impactor shall be guided to exclude significant lateral, vertical or rotational movement at time-zero.

▼B

- 3.3.6. Allow a period of at least 30 minutes between successive tests on the same leg.
- 3.3.7. The data acquisition system, including transducers, shall conform to the specifications for CFC 600, as described in Appendix 5 to this Annex.
- 3.4. **Performance specification**
- 3.4.1. When the heel of each foot is impacted at $4,4 \pm 0,2$ m/s in accordance with paragraph 3.3, the maximum impactor acceleration shall be 340 ± 50 g.

Figure 1
Tibia impact test — test set-up specifications

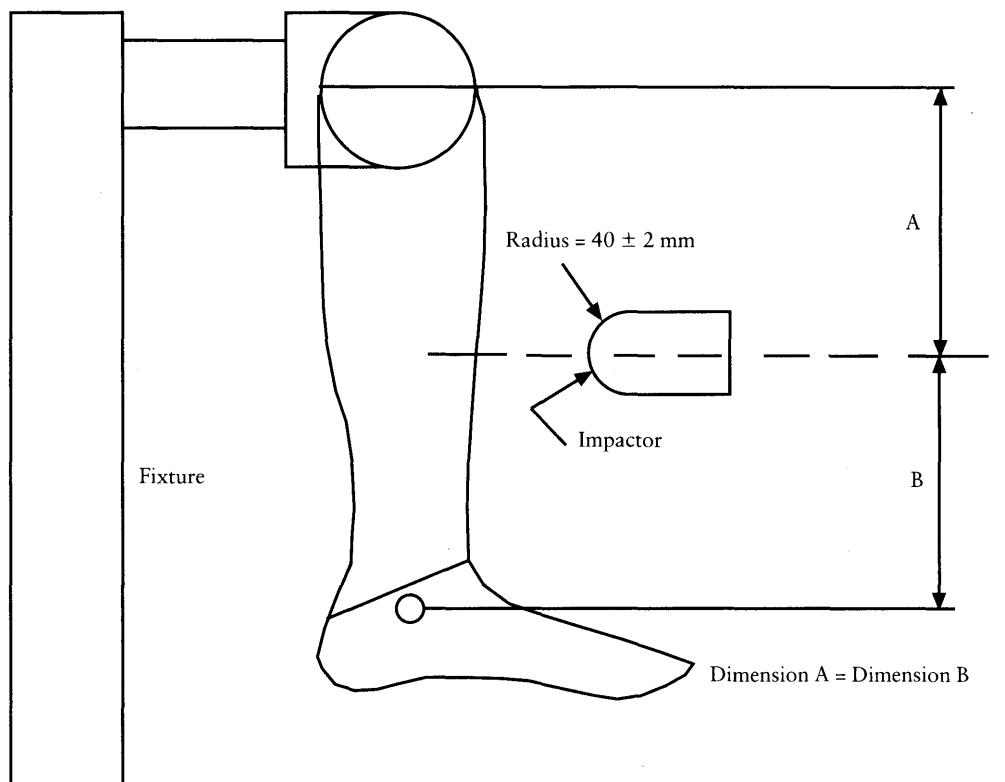

▼B

Figure 1a
Upper foot impact test — test set-up specifications

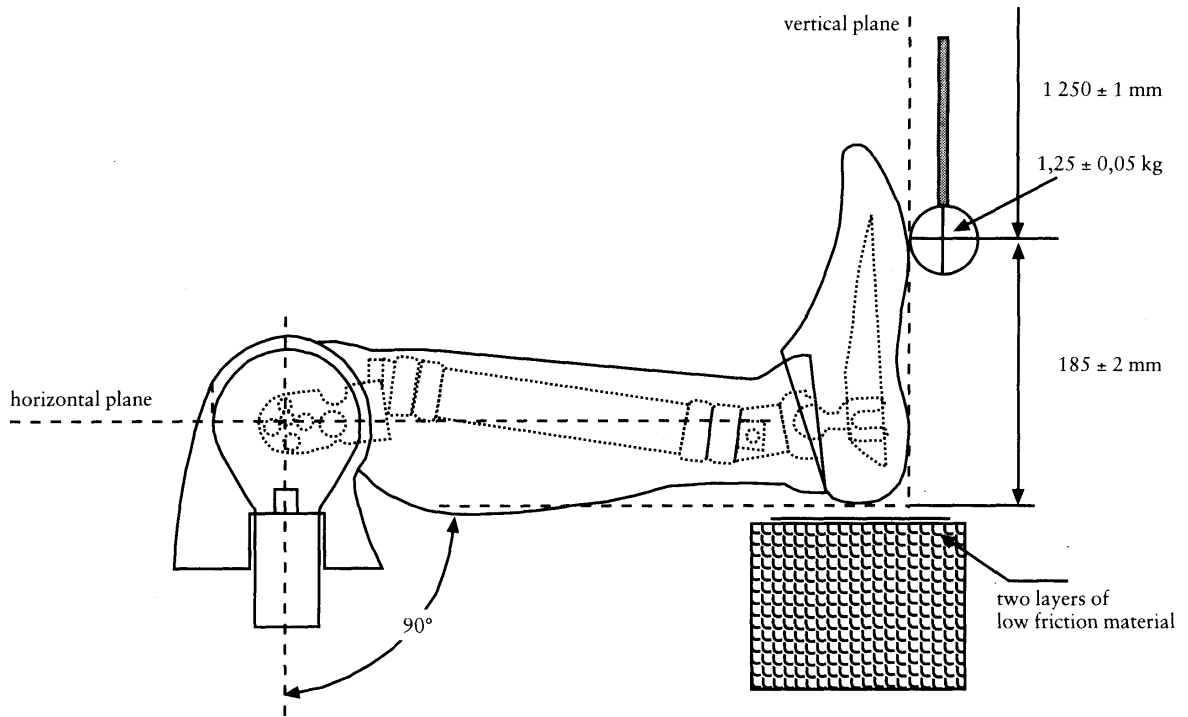
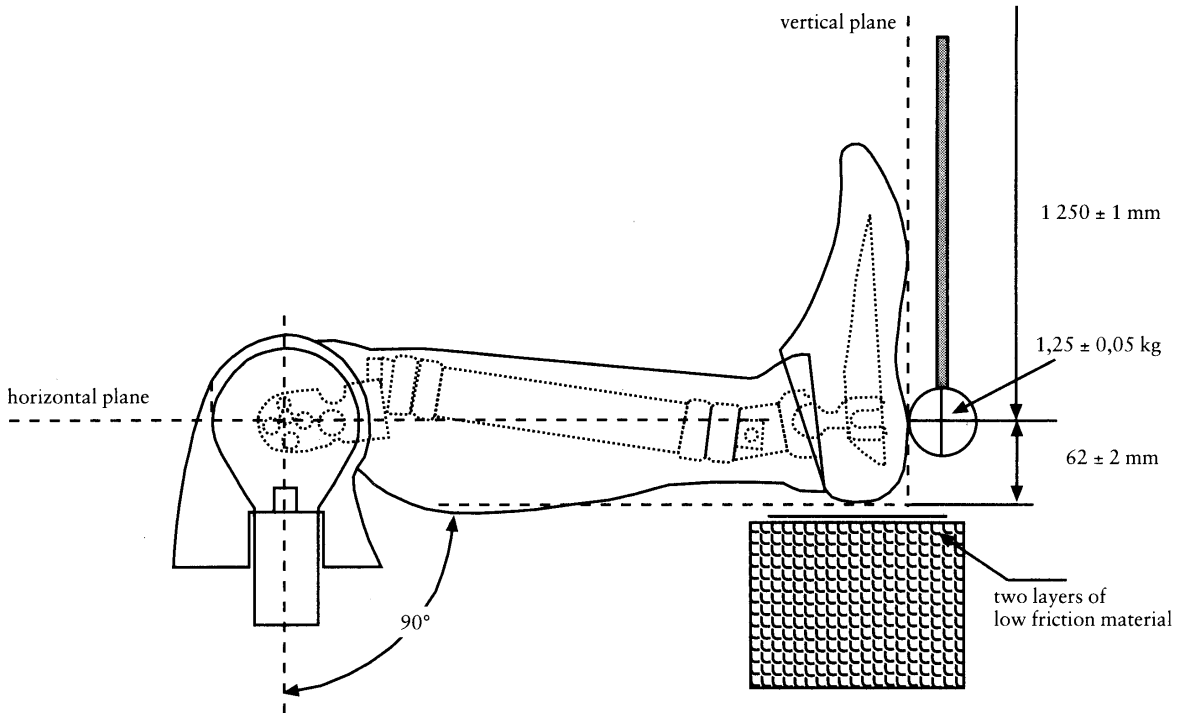
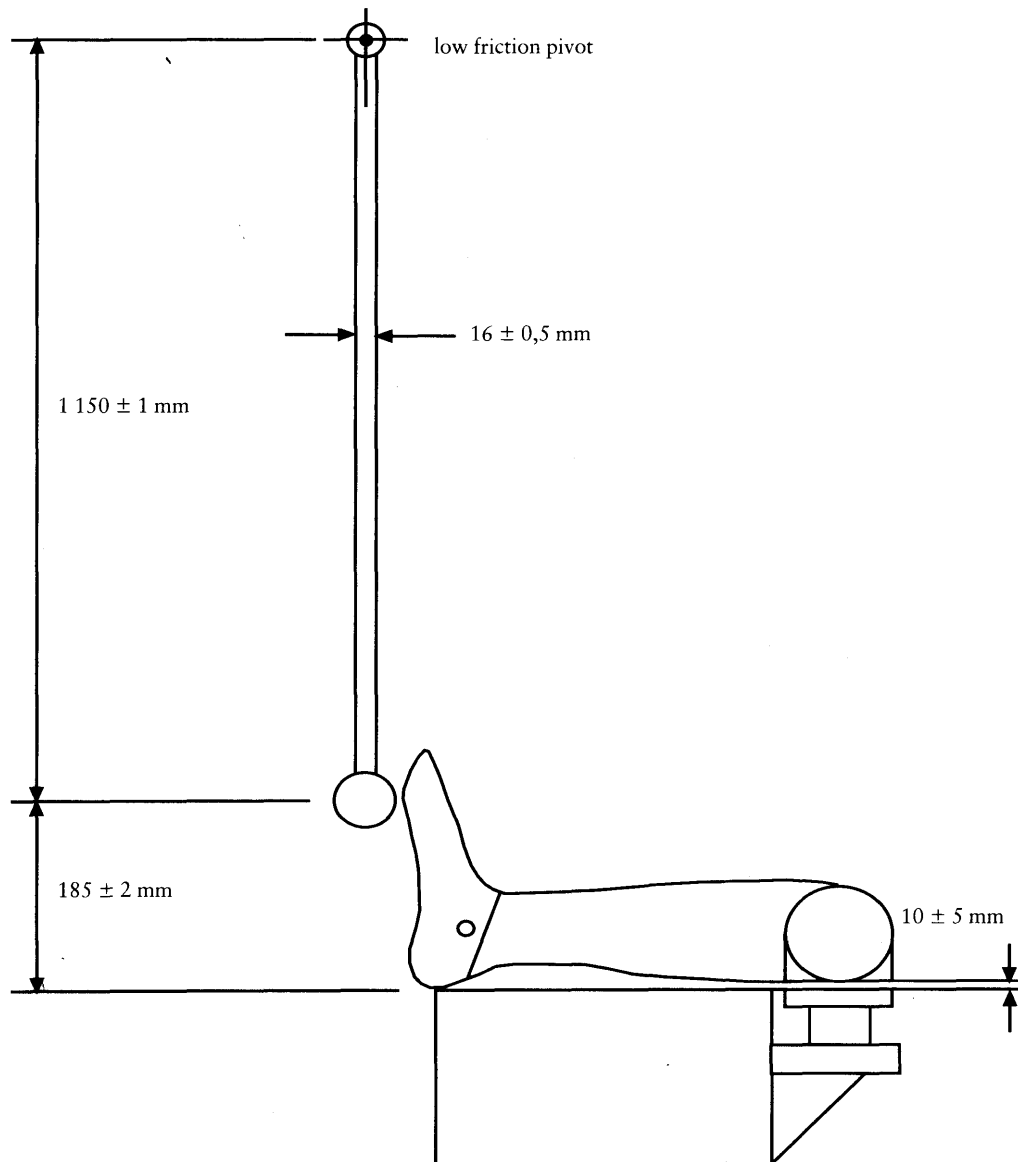

Figure 1b
Lower foot impact test — test set-up specifications



▼B

Figure 2
Upper foot impact test — test set-up specifications



▼B

Figure 3
Lower foot impact test — test set-up specifications

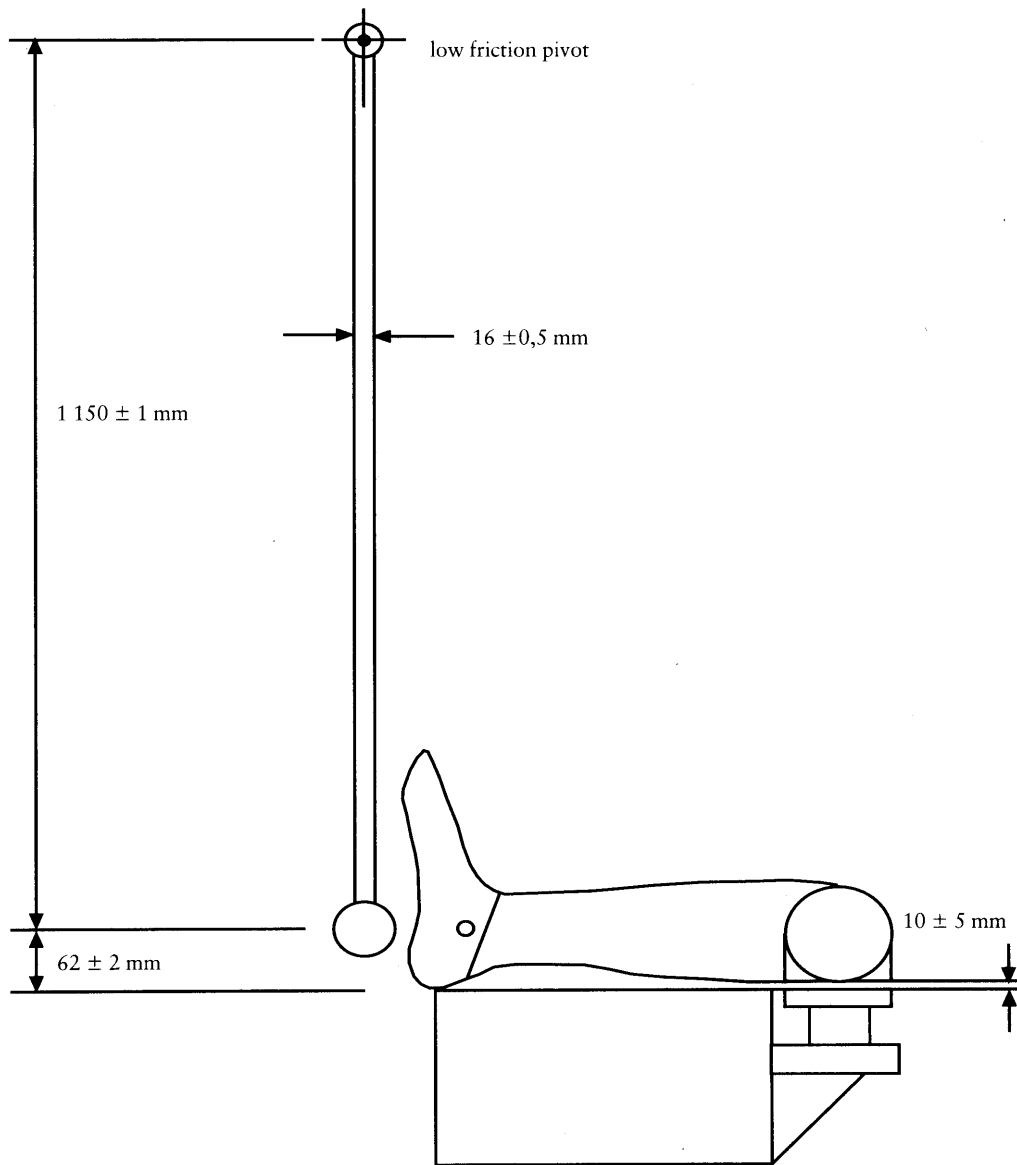

▼B

Figure 3a
Pendulum impactor

Material: aluminium alloy
 Mass of arm: 285 ± 5 g
 Mass of impact cylinder:
 $1\,250 \pm 20$ g

