

This document is meant purely as documentation tool and the institutions do not assume any liability for its contents

► **B**

DIRECTIVE 96/27/EC OF THE EUROPEAN PARLIAMENT AND OF THE COUNCIL

of 20 May 1996

**on the protection of occupants of motor vehicles in the event of a side impact and amending Directive
70/156/EEC**

(OJ L 169, 8.7.1996, p. 1)

Corrected by:

► **C1** Corrigendum, OJ L 102, 19.4.1997, p. 46 (96/27)



**DIRECTIVE 96/27/EC OF THE EUROPEAN PARLIAMENT AND OF
THE COUNCIL
of 20 May 1996**

**on the protection of occupants of motor vehicles in the event of a side
impact and amending Directive 70/156/EEC**

THE EUROPEAN PARLIAMENT AND THE COUNCIL OF THE
EUROPEAN UNION,

Having regard to the Treaty establishing the European Community, and in particular Article 100a thereof,

Having regard to Council Directive 70/156/EEC of 6 February 1970 on the approximation of the laws of the Member States relating to the type-approval of motor vehicles and their trailers⁽¹⁾, and in particular Article 13 (4) thereof,

Having regard to the proposal from the Commission⁽²⁾,

Having regard to the opinion of the Economic and Social Committee⁽³⁾,

Acting in accordance with the procedures laid down in Article 189b of the Treaty⁽⁴⁾,

Whereas the total harmonization of technical requirements for motor vehicles is necessary in order fully to achieve the internal market;

Whereas in order to reduce the number of road accident casualties in Europe, it is necessary to introduce legislative measures for improving the protection of occupants of motor vehicles in the event of a side impact as much as possible; whereas this Directive introduces side impact test requirements, including biomechanical criteria, to ensure that a reasonable level of side impact resistance is provided;

Whereas these requirements should be regarded as an interim measure and will need to be reviewed in the light of further research and experience gained during the first two years of type-approval tests carried out in accordance with this Directive; whereas the establishment of more stringent standards will ensure a higher level of safety in future;

Whereas this Directive will be one of the separate directives which must be complied with in order to ensure the conformity of vehicles with the requirements of the EC type-approval procedure established by Directive 70/156/EEC; whereas, therefore, the provisions of Directive 70/156/EEC relating to vehicle systems, components and separate technical units apply to this Directive;

Whereas the ►C1 procedure ◀ for determining the seating reference point in motor vehicles is given in Annex III to Council Directive 77/649/EEC of 27 September 1977 on the approximation of the laws of the Member States relating to the field of vision of motor vehicle drivers⁽⁵⁾; whereas it is therefore unnecessary to repeat it in this Directive; whereas reference should be made in this Directive to Council Directive 70/387/EEC of 27 July 1970 on the approximation of the laws of the Member States relating to the doors of motor vehicles and their trailers⁽⁶⁾, Council Directive 74/483/EEC of 17 September 1974 on the approximation of the laws of the Member States relating to the external projections of motor vehicles⁽⁷⁾, Council Directive 76/115/EEC of 18 December 1975 on the approximation of the laws of the Member States relating to anchorages for motor-vehicle safety belts⁽⁸⁾ and to ISO standard 6487:1987;

(1) OJ No L 42, 23. 2. 1970, p. 1. Directive as last amended by Commission Directive 95/54/EC (OJ No L 266, 8. 11. 1995, p. 1).

(2) OJ No C 396, 31. 12. 1994, p. 1.

(3) OJ No C 256, 2. 10. 1995, p. 18.

(4) Opinion of the European Parliament of 12 July 1995 (OJ No C 249, 25. 9. 1995, p. 47), Council common position of 23 November 1995 (OJ No C 353, 30. 12. 1995, p. 1) and Decision of the European Parliament of 29 February 1996 (OJ C No 78, 18. 3. 1996, p. 17) and Council Decision of 6 May 1996.

(5) OJ No L 267, 19. 10. 1977, p. 1. Directive as last amended by Commission Directive 90/630/EEC (OJ No L 341, 6. 12. 1990, p. 20).

(6) OJ No L 176, 10. 8. 1970, p. 5.

(7) OJ No L 266, 2. 10. 1974, p. 4. Directive as last amended by Directive 87/354/EEC (OJ No L 192, 11. 7. 1987, p. 43).

(8) OJ No L 24, 30. 1. 1976, p. 6. Directive as last amended by Commission Directive 90/629/EEC (OJ No L 341, 6. 12. 1990, p. 14).

▼B

Whereas the technical requirements of this Directive are based on United Nations Economic Commission for Europe document TRANS/SC1/WP29/396,

HAVE ADOPTED THIS DIRECTIVE:

Article 1

For the purposes of this Directive, 'vehicle' shall have the meaning given to it in Article 2 of Directive 70/156/EEC.

Article 2

1. No Member State may, on grounds concerning the protection of occupants of vehicles in the event of a side ►C1 impact ◀ :

— refuse, in respect of a vehicle type, to grant EC type-approval or national type-approval, or

— prohibit the registration, sale or entry into service of a vehicle,

if it complies with the requirements of this Directive.

2. With effect from 1 October 1998, Member States may no longer grant:

— EC type-approval for a vehicle type in accordance with Article 4 of Directive 70/156/EEC,

— national type-approval for a vehicle type,

unless the vehicle satisfies the requirements of this Directive.

►C1 3. Paragraph 2 shall not apply to vehicle types approved before 1 October 1998 pursuant to any two of the following Directives: ◀ 70/387/EEC (door latches and hinges), 74/483/EEC (external projections) and 76/115/EEC (anchorage for motor-vehicle safety belts) nor, where appropriate, to subsequent extensions to those type-approvals.

4. With effect from 1 October 2003, Member States ►C1 shall consider ◀ certificates of conformity which accompany new vehicles in accordance with Directive 70/156/EEC to be no longer valid for the purposes of Article 7 (1) of that ►C1 Directive if they ◀ do not certify that the vehicles conform to the requirements of the Annexes to this Directive.

Article 3

In Part 1 of Annex IV to Directive 70/156/EEC the table shall be supplemented as follows:

Subject	Directive number	Official Journal reference	Applicability											
			M ₁	M ₂	M ₃	N ₁	N ₂	N ₃	O ₁	O ₂	O ₃	O ₄		
►C1 54. Side impact protection ◀	►C1 96/27/EC	L 169, 8. 7. 1996, p. 1. ◀	×				×							

Article 4

►C1 In the framework of the adaptation of this Directive to technical progress, within two years from the date mentioned in Article 2 (2) a review shall be held by the ◀ Commission. It shall be based on a review of the technical criteria and, in particular, the viscous criterion, front seat position and the ground clearance of the barrier. The review criteria will include *inter alia* accident research data, full scale car-to-car test results and cost-benefit considerations. The review will examine the potential gains in ►C1 occupant ◀ protection and the industrial feasibility of increasing the ground clearance of the barrier. ►C1 The results of this review will be submitted to the European Parliament and the Council in a report drawn up by the Commission. ◀

▼B*Article 5*

1. Member States shall bring into force the laws, regulations and administrative provisions necessary to comply with this Directive by 20 May 1997 at the latest. They shall forthwith inform the Commission thereof.

When Member States adopt these provisions, they shall contain a reference to this Directive or be accompanied by such reference at the time of their official publication. The procedure for making such reference shall be adopted by the Member States.

2. Member States shall communicate to the Commission the texts of the main provisions of national law which they adopt in the field governed by this Directive.

Article 6

This Directive shall enter into force on the 20th day following that of its publication in the *Official Journal of the European Communities*.

Article 7

This Directive is addressed to the Member States.



LIST OF ANNEXES

- ANNEX I *Administrative provisions for the type-approval of a vehicle type*
1. Application for EC type-approval
 2. EC type-approval
 3. Modification of the type and ► CI amendments to type-approvals ◀
 4. Conformity of production
 - Appendix 1: Information document
 - Appendix 2: Type-approval certificate
- ANNEX II *Technical requirements*
1. Scope
 2. Definitions
 3. Specifications and tests
 - Appendix 1: Impact test procedure
 - Appendix 2: Mobile deformable barrier characteristics
 - Appendix 3: Technical description of the side impact dummy
 - Appendix 4: Installation of the side impact dummy
 - Appendix 5: Partial test

▼B*ANNEX I***ADMINISTRATIVE PROVISIONS FOR THE TYPE-APPROVAL OF A VEHICLE TYPE****1. APPLICATION FOR EC TYPE-APPROVAL****▼C1**

- 1.1. Applications for EC type-approval pursuant to Article 3 (4) of Directive 70/156/EEC of a vehicle type with regard to the protection of occupants of motor vehicles in the event of a side impact must be submitted by the manufacturer.

▼B

- 1.2. A model for the information document is given in Appendix 1.
- 1.3. A vehicle representative of the vehicle type to be approved must be submitted to the technical service responsible for conducting the type-approval tests.

▼C1

- 1.4. The manufacturer is entitled to submit any data and test results which make it possible to establish with a sufficient degree of confidence that compliance with the requirements can be achieved.

▼B**2. EC TYPE-APPROVAL**

- 2.1. **►C1** Where the vehicle type satisfies the relevant requirements, EC type-approval pursuant to Article 4 (3) and, if applicable, 4 (4) of Directive 70/156/EEC will be granted. **◄**

- 2.2. A model for the EC type-approval certificate is given in Appendix 2.
- 2.3. A type-approval number in accordance with Annex VII to Directive 70/156/EEC is assigned to each vehicle type approved. The same Member State must not assign the same number to another type of vehicle.
- 2.4. **►C1** In case of doubt **◄**, in order to verify that the vehicle conforms to the requirements of this Directive, account must be taken of any data or test results provided by the manufacturer which **►C1** may be taken into consideration **◄** in establishing the validity of the type-approval test performed by the type approval authority.

3. MODIFICATION OF THE TYPE AND AMENDMENTS TO TYPE-APPROVALS

- 3.1. In the case of amendments to type-approvals granted pursuant to this Directive, the provisions of Article 5 of Directive 70/156/EEC are applicable.
- 3.2. Any modification of the vehicle affecting the general form of the structure of the vehicle, or any variation in the reference mass greater than 8 % which in the judgment of the authority would have a marked influence on the results of the test necessitates a repetition of the test as described in Appendix 1 of Annex II.
- 3.3. If the technical service, after consulting the vehicle manufacturer, considers that modifications to a vehicle type are insufficient to warrant a complete retest then a partial test may be used. This would be the case if the reference mass differs by no more than 8 % from the original vehicle, or the number of front seats is unchanged. Variations of seat-type or interior fittings do not automatically entail a full retest. An example of how to approach this problem is given in Appendix 5 of Annex II.

4. CONFORMITY OF PRODUCTION

- 4.1. As a general rule, measures to ensure the conformity of production must be taken in accordance with the provisions laid down in Article 10 of Directive 70/156/EEC.

*Appendix 1***Information document No . . .**

pursuant to Annex I to Council Directive 70/156/EEC⁽¹⁾ relating to the EC type-approval of a vehicle with respect to the protection of occupants of motor vehicles in the event of a side impact

The following information, if applicable, must be supplied in triplicate and include a list of contents. Any drawings must be supplied in appropriate scale and in sufficient detail on size A4 or on a folder of A4 format. Photographs, if any, must show sufficient detail.

If the systems, components or separate technical units have electronic controls, information concerning their performance must be supplied.

- 0. GENERAL
 - 0.1. Make (trade name of manufacturer):
 - 0.2. Type and general commercial description(s):
 - 0.3. Means of identification of type, if marked on the vehicle (b):
 - 0.3.1. Location of that marking:
 - 0.4. Category of vehicle (c):
 - 0.5. Name and address of manufacturer:
 - 0.8. Address(es) of assembly plant(s):
- 1. GENERAL CONSTRUCTION CHARACTERISTICS OF THE VEHICLE
 - 1.1. Photographs and/or drawings of a representative vehicle:
 - 1.6. Position and arrangement of the engine:
- 2. MASSES AND DIMENSIONS (e) (in kg and mm) (refer to drawing where applicable)
 - 2.4. Range of vehicle dimensions (overall):
 - 2.4.2. Chassis with bodywork:
 - 2.4.2.1. Length (i):
 - 2.4.2.2. Width (k):
 - 2.4.2.6. Ground clearance (as defined in section 4.5.4 of part of Annex II A):
 - 2.4.2.7. Distance between axles:
 - 2.6. Mass of the vehicle with bodywork in running order or mass of the chassis and cab if the manufacturer does not supply the bodywork (including coolant, oils, fuel, tools, spare wheel and driver) (o) (maximum and minimum mass for each version):
 - 2.6.1. Distribution of this mass among the axles and, in the case of a semi-trailer with centre axle, the load on the coupling point (maximum and minimum mass for each version):
- 9. BODYWORK
 - 9.1. Type of bodywork:
 - 9.2. Materials used and methods of construction:
 - 9.3. Occupant doors, latches and hinges:
 - 9.3.1. Door configuration and number of doors:
 - 9.3.1.1. Dimensions, direction and maximum angle of opening:

⁽¹⁾ The item numbers and footnotes used in this information document correspond to those set out in Annex I to Directive 70/156/EEC, published in Directive 95/53/EEC. Items not relevant for the purposes of this Directive are omitted.

▼B

- 9.3.2. Drawing of latches and hinges and of their position in the doors:
- 9.3.3. Technical description of latches and hinges:
- 9.10. Interior fittings:
- 9.10.3. Seats:
- 9.10.3.1. Number:
- 9.10.3.2. Position and arrangement:
- 9.10.3.3. Mass:
- 9.10.3.4. Characteristics: description and drawing of:
- 9.10.3.4.1. the seats and their anchorages:
- 9.10.3.4.2. the adjustment system:
- 9.10.3.4.3. the displacement and locking systems:
- 9.10.3.4.4. the seat belt anchorages (if incorporated in the seat structure):
- 9.10.3.5. Coordinates or drawing of the R point (*)
- 9.10.3.5.1. Driver's seat:
- 9.10.3.6. Design seat back angle:
- 9.10.3.6.1. Driver's seat:
- 9.10.3.7. Range of seat adjustment:
- 9.10.3.7.1. Driver's seat:
- 9.12. Safety belts and/or other restraint systems:
- 9.12.1. Number and position of safety belts and restraint systems and seats on which they can be used:
(R = right-hand seat, C = centre seat; L = left-hand seat)

▶ ⁽¹⁾ R/C/L◀	▶ ⁽²⁾ Complete EC type-approval mark◀	Variant, if applicable
	First row of seats Second row of seats etc. [...]	
	Optional extras (e. g. for height adjusting seats, pre-loading device, etc.)	

- 9.12.2. Number and position of safety-belt anchorages and proof of compliance with Directive 76/115/EEC, as amended (i.e. type-approval number or test report):
- 9.21. Side-impact resistance:
- 9.21.1. A detailed description, including photographs and/or drawings, of the vehicle type with respect to the structure, the dimensions, the design and the constituent materials, the side walls of the passenger compartment (exterior and interior), including specific details of the protection system, where applicable:

Date, file

▶⁽¹⁾C1

▶⁽²⁾C1

▼B

Appendix 2

MODEL

[maximum format: A4 (210 × 297 mm)]

TYPE-APPROVAL CERTIFICATE

<p style="text-align: center;">STAMP OF TYPE-APPROVAL AUTHORITY</p>

Communication concerning the:

- type-approval⁽¹⁾
- extension of type-approval⁽¹⁾
- refusal of type-approval⁽¹⁾
- withdrawal of type-approval⁽¹⁾

►⁽⁰⁾ of a type ◀ of vehicle/component/separate unit⁽¹⁾ with regard to Directive . . . /EC, as last amended by Directive . . . /EC⁽¹⁾.

Type-approval number:

Reason for extension:

PART I

- 0.1. Make (trade name of manufacturer):
- 0.2. Type and general commercial description(s):
- 0.3. Means of identification of type, if marked on the vehicle/component/separate technical unit⁽¹⁾(²): ..
- 0.3.1. Location of that marking:
- 0.4. Category of vehicle⁽³⁾:
- 0.5. Name and address of manufacturer:
- 0.7. In the case of components and separate technical units, location and method of affixing of the EC type-approval mark:
- 0.8. Address(es) of assembly plant(s):

PART II

1. Additional information (where applicable) (see Addendum):
2. Technical service responsible for carrying out the tests:
3. Date of test report:
4. Number of test report:
5. Remarks (if any) (see Addendum):
6. Place:
7. Date:
8. Signature:
9. The index to the type-approval file sent to the competent authority, which may be obtained on request, is attached.

⁽¹⁾ Delete where not applicable.

⁽²⁾ If the means of identification of type contains characters not relevant to a description of the vehicle, component or separate technical unit types covered by this type-approval certificate, such characters are to be represented in the documentation by the symbol '?' (e.g. ABC??123??).

⁽³⁾ As defined in Annex II (A) to Directive 70/156/EEC.

►⁽⁰⁾C1

▼B

ADDENDUM

**to EC type-approval certificate No ...
concerning the type-approval of a vehicle type pursuant to Directive .../.../EC.**

1. Additional information:
- 1.1. Brief description of the vehicle type as regards its structure, dimensions, lines and constituent materials:
- 1.2. Description of the protective system installed in the passenger compartment:
- 1.3. Description of the interior arrangements or fittings that might affect the tests:
- 1.4. Location of engine: forward/rear/central⁽¹⁾:
- 1.5. Drive: front-wheel: rear-wheel⁽¹⁾:
- 1.6. Mass of vehicle submitted for testing —
front axle:
rear axle:
total:
2. Type of barrier used in type-approval test:
5. Remarks: (e.g. valid for left-hand drive and right-hand drive vehicles):

⁽¹⁾ Delete where not applicable.



ANNEX II

TECHNICAL REQUIREMENTS

1. SCOPE

This Directive applies to the lateral impact behaviour of the structure of the passenger compartment of M₁ and N₁ categories of vehicles where the 'R' point of the lowest seat is not more than 700 mm from ground level when the vehicle is in the condition corresponding to the reference mass defined in Section 2.10, with the exception of multi-stage build vehicles produced in quantities not exceeding those fixed for small series.

2. DEFINITIONS

For the purposes of this Directive:

- 2.1. 'Type-approval of a vehicle' means the type-approval of a vehicle type with regard to the behaviour of the structure of the passenger compartment in a lateral impact.
- 2.2. 'Vehicle type' means a category of power-driven vehicles which do not differ in such essential respects as:
 - 2.2.1. the length, width and ground clearance of the vehicles, in so far as they have a negative effect on the performance prescribed in this Directive;
 - 2.2.2. the structure, dimensions, lines and materials of the side walls of the passenger compartment in so far as they have a negative effect on the performance prescribed in this Directive;
 - 2.2.3. the lines and inside dimensions of the passenger compartment and the type of protective systems, in so far as they have a negative effect on the performance prescribed in this Directive;
 - 2.2.4. the siting of the engine (front, rear or centre);
 - 2.2.5. the unladen mass, ►C1 in so far as it has a negative effect ◄ on the performance prescribed in this Directive;
 - 2.2.6. the optional arrangements or interior fittings in so far as they have a negative effect on the performance prescribed in this Directive;
 - 2.2.7. the type of front seat(s) and position of the R point in so far as they have a negative effect on the performance prescribed in this Directive.
- 2.3. 'Passenger compartment' means the space for occupant accommodation, bounded by the roof, floor, side walls, doors, outside glazing and front bulkhead and the plane of the rear compartment bulkhead or the plane of the rear seat-back support.
- 2.4. 'R point' or 'seating reference point' means the reference point specified by the vehicle manufacturer which:
 - 2.4.1. has coordinates determined in relation to the vehicle structure;
 - 2.4.2. corresponds to the theoretical position of the point of torso/thighs rotation (H point) for the lowest and most rewarded normal driving position or position of use given by the vehicle manufacturer for each seating position specified.
- 2.5. 'H point' means the point as defined in Directive 77/649/EEC.
- 2.6. 'Capacity of the fuel tank' means the fuel-tank capacity as specified by the manufacturer of the vehicle.
- 2.7. 'Transverse plane' means a vertical plane perpendicular to the median longitudinal vertical plane of the vehicle.
- 2.8. 'Protective system' means devices intended to restrain and/or protect the occupants.
- 2.9. 'Type of protective system' means a category of protective devices which do not differ in such essential respects as their:
 - technology,
 - geometry, or
 - constituent materials.
- 2.10. 'Reference mass' means the unladen mass of the vehicle increased by a mass of 100 kg (i.e. the mass of the side impact dummy and its instrumentation).
- 2.11. 'Unladen mass' means the mass of the vehicle in running order without driver, passengers or load, but with the fuel tank filled to 90 % of its capacity and the usual set of tools and spare wheel on board, where applicable.

▼B

- 2.12. 'Mobile deformable barrier' means the apparatus with which the test vehicle is impacted. It consists of a trolley and an impactor.
- 2.13. 'Impactor' means a crushable section mounted on the front of the mobile deformable barrier.
- 2.14. 'Trolley' means a wheeled-frame free to travel along its longitudinal axis at the point of impact. Its front block supports the impactor.
- 2.15. 'Multi-stage build' means the procedure whereby two or more manufacturers separately and sequentially participate in the construction of a vehicle.

3. SPECIFICATIONS AND TESTS

- 3.1. The vehicle must undergo a test in accordance with Appendix 1 to this Annex.
- 3.1.1. The test is carried out on the driver's side unless asymmetric side structures, if any, are so different as to affect the performance in a side impact. In that case either of the alternatives in 3.1.1.1 or 3.1.1.2 may be used by agreement between the manufacturer and the service responsible for the tests.
- 3.1.1.1. The manufacturer must provide the type-approval authority with information regarding the compatibility of performances in comparison with the driver's side where the test is being carried out on that side.
- 3.1.1.2. The type-approval authority, after ascertaining the characteristics of the construction of the vehicle, may decide to have the test performed on the side opposite the driver, which is regarded as the less favourable option.
- 3.1.2. The test authority, after consulting the manufacturer, may require the test to be carried out with the seat in a position other than the one indicated in Section 5.5.1 of Appendix 1⁽¹⁾. That position will be specified in the test report.
- 3.1.3. The result of this test is considered satisfactory if the conditions set out in 3.2 and 3.3 are satisfied.

3.2. *Performance criteria*

- 3.2.1. The ►C1 performance criteria as ◀ determined for the impact test in accordance with the Addendum to Appendix 1 to this Annex must meet the following conditions:
- 3.2.1.1. ►C1 The head performance ◀ criterion (HPC) must be no more than 1 000; if there is no head contact, the HPC is not measured or calculated but recorded as 'No head contact'.

- 3.2.1.2. The thorax performance criteria must be:

- (a) rib deflection criterion (RDC) no more than 42 mm;
- (b) soft tissue criterion (V*C) no more than 1,0 m/s.

For a transitional period of two years after the date shown in Article 2 (2) of this Directive the V*C value is not a pass/fail criterion for the type-approval tests, but this value has to be recorded in the test report and to be collected by the type-approval authorities. After this transitional period, the V*C value of 1,0 m/s applies as a pass/fail criterion unless, or until an alternative value is approved by the Committee for Adaptation to Technical Progress.

- 3.2.1.3. The pelvis performance criterion must be:

pubic symphysis peak force (PSPF) no more than 6 kN.

- 3.2.1.4. The abdomen performance criterion must be:

abdominal peak force (APF) no more than 2,5 kN internal force (equivalent to external force of 4,5 kN).

3.3. *Particular requirements*

- 3.3.1. No door must open during the test.
- 3.3.2. After the impact, it must be possible without the use of tools:
- 3.3.2.1. to open a sufficient number of doors provided for normal entry and exit of ►C1 occupants ◀, and if necessary tilt the seat-backs or seats to allow evacuation of all occupants;
- 3.3.2.2. to release the dummy from the protective system;
- 3.3.2.3. to remove the dummy from the vehicle.
- 3.3.3. No interior device or component must become detached in such a way as to increase considerably the risk of injury from sharp projections or jagged edges.

⁽¹⁾ Until 30 September 2000, for the purposes of the test requirements, the range of normal longitudinal adjustments must be limited such that the H-point lies within the length of the door aperture.

▼B

- 3.3.4. Ruptures resulting from permanent deformation are ►**C1** acceptable provided ◀ these do not increase the risk of injury.
- 3.3.5. If there is continuous leakage of liquid from the fuel-feed installation after the collision, the rate of leakage must not exceed ►**C1** 5×10^{-4} kg/s ◀ ; if the liquid from the fuel-feed system mixes with liquids from the other systems and the various liquids cannot easily be separated and identified, all the liquids collected must be taken into account in evaluating the continuous leakage.

*Appendix 1***IMPACT TEST PROCEDURE**

1. INSTALLATIONS

1.1. *Testing ground*

The test area must be large enough to accommodate the mobile deformable barrier propulsion system and to permit ►**C1** post-impact displacement ◀ of the vehicle impacted, and installation of the test equipment. The block in which vehicle impact and displacement occur must be horizontal, flat and ►**C1** smooth, and representative of a normal, dry, smooth road surface ◀ .

2. TEST CONDITIONS

2.1. The vehicle to be tested must be stationary.

2.2. The mobile deformable barrier must have the characteristics set out in Appendix 2 to Annex II. ►**C1** Requirements for verifying them ◀ are given in the Addendum to Appendix 2. The mobile deformable barrier must be equipped with a suitable device to prevent a second impact on the struck vehicle.

2.3. The trajectory of the median longitudinal vertical plane of the mobile deformable barrier must be perpendicular to the median longitudinal vertical plane of the impacted vehicle.

2.4. The median longitudinal vertical plane of the mobile deformable barrier must be coincident within ± 25 mm with a transverse vertical plane passing through the R point of the front seat adjacent to the struck side of the tested vehicle. The horizontal median plane limited by the external lateral vertical planes of the front face must, at the moment of impact, be within two planes determined before the test and situated 25 mm above and below the previously defined plane.

2.5. Instrumentation must comply with ISO standard 6487:1987 unless otherwise specified in this Directive.

2.6. The stabilized temperature of the test dummy at the time of the side impact test must be 22 ± 4 °C.

3. TEST SPEED

Mobile deformable barrier speed at the moment of impact must be ►**C1** 50 ± 1 km/h ◀ . This speed must be stabilized at least 0,5 m before impact. Accuracy of measurement: 1 %. However, if the test was performed at a higher impact speed and the vehicle met the requirements, the test is considered satisfactory.

4. STATE OF THE VEHICLE

4.1. *General specification*

The test vehicle must be representative of the series production, include all the equipment normally fitted and be in normal running order. Some components may be omitted or replaced by equivalent masses where this omission or substitution clearly has no effect on the results of the test.

4.2. *Vehicle equipment specification*

The test vehicle must have all the optional arrangements or fittings likely to influence the results of the test.

4.3. *Mass of the vehicle*

4.3.1. The vehicle to be tested must have the reference mass as defined in Section 2.10 of Annex II to this Directive. The mass of the vehicle is adjusted to within ± 1 % of the reference mass.

4.3.2. The fuel tank must be filled with water to a mass equal to 90 % of the mass of a full load of fuel as specified by the manufacturer.

4.3.3. All the other systems (brakes, cooling, etc.) may be empty; in this case, the mass of the liquids must be offset.

4.3.4. If the mass of the measuring apparatus on board the vehicle exceeds the 25 kg allowed, it may be offset by reductions which have no noticeable effect on the results of the test.

4.3.5. The mass of the measuring apparatus must not change each axle reference load by more than 5 %, each variation not exceeding 20 kg.

▼B

5. PREPARATION OF THE VEHICLE
 - 5.1. The side windows must be closed, at least on the struck side.
 - 5.2. The doors must be closed, but not locked.
 - 5.3. The transmission must be placed in neutral and the parking brake disengaged.
 - 5.4. The comfort adjustments of the seats, if any, must be adjusted to the position specified by the vehicle manufacturer.
 - 5.5. The seat containing the dummy, and its elements, if adjustable, must be adjusted as follows.
 - 5.5.1. The longitudinal adjustment device is placed with the locking device engaged in the position that is nearest to midway between the foremost and rearmost positions; if this position is between two notches, the rearmost notch is used.
 - 5.5.2. The head restraint is adjusted such that its top surface is level with the centre of gravity of the dummy's head; if this is not possible, the head restraint must be in the uppermost position.
 - 5.5.3. Unless otherwise specified by the manufacturer, the seat back must be set such that the torso reference line of the three-dimensional H point machine is set at an angle of $25^\circ \pm 1^\circ$ towards the rear.
 - 5.5.4. All other seat adjustments must be at the mid-point of available travel, however, height adjustment must be at the position corresponding to the fixed seat, if the vehicle type is available with adjustable and fixed seats. If locking positions are not available at the respective mid-points of travel, the positions immediately rearward, down, or outboard of the mid-points are used. For rotational adjustments (tilt), 'rearward' means the adjustment direction which moves the head of the dummy rearwards. If the dummy protrudes outside the normal passenger volume, e.g. head into roof lining, then 10 mm clearance must be provided, using secondary adjustments, seat-back angle, or fore-aft adjustment in that order.
 - 5.6. Unless otherwise specified by the manufacturer, the other front seats must, if possible, be adjusted to the same position as the seat containing the dummy.
 - 5.7. If the steering wheel is adjustable, all adjustments are positioned to their mid-travel locations.
 - 5.8. Tyres must be inflated to the pressure specified by the vehicle manufacturer.
 - 5.9. The test vehicle must be set horizontal about its roll axis and maintained by supports in that position until the side impact dummy is in place and after all preparatory work is complete.
 - 5.10. The vehicle must be at its normal attitude corresponding to the conditions set out in 4.3. Vehicles with suspension enabling their ground clearance to be adjusted must be tested under the normal conditions of use at 50 km/h as defined by the vehicle manufacturer. This is assured by means of additional supports, if necessary, but such supports must have no influence on the crash behaviour of the test vehicle during the impact.
6. SIDE IMPACT DUMMY AND ITS INSTALLATION
 - 6.1. The side impact dummy must comply with the specifications given in Appendix 3 and be installed in the front seat on the impact side according to the procedure given in Appendix 4 to this Annex.
 - 6.2. The safety belts or other restraint systems specified for the vehicle must be used. Belts must be of an approved type, conforming to Directive 77/541/EEC and mounted on anchorages conforming to Directive 76/115/EEC.
 - 6.3. The safety belt or restraint system must be adjusted to fit the dummy in accordance with the manufacturer's instructions; if there are no manufacturer's instructions, the height adjustment, if provided, must be set at middle position; if this position is not available, the position immediately below is used.
7. MEASUREMENTS TO BE MADE ON THE SIDE IMPACT DUMMY
 - 7.1. The readings of the following measuring devices are to be recorded.
 - 7.1.1. Measurements in the head of the dummy

The resultant triaxial acceleration referring to the head centre of gravity. The head channel instrumentation must comply with ISO 6487:1987,
CFC: 1 000 Hz, and
CAC: 150 g.
 - 7.1.2. Measurements in the thorax of the dummy

The three thorax rib deflection channels must comply with ISO 6487:1987,
CFC: 1 000 Hz,

▼B

CAC: 60 mm.

7.1.3. Measurements in the pelvis of the dummy

The pelvis force channel must comply with ISO 6487:1987,

CFC: 1 000 Hz,

CAC: 15 kN.

7.1.4. Measurements in the abdomen of the dummy

The abdomen force channels must comply with ISO 6487:1987,

CFC: 1 000 Hz,

CAC: 5 kN.



Appendix 1 — Addendum 1

DETERMINATION OF PERFORMANCE CRITERIA

The required results of the tests are specified in Section 3.2 of Annex II.

1. HEAD PERFORMANCE CRITERION (HPC)

When head contact takes place, this performance criterion is calculated for the total duration between the ► **C1** first and last instants of contact ◀ .

HPC is the maximum value of the expression:

$$(t_2 - t_1) \left[\frac{1}{(t_2 - t_1)} \int_{t_1}^{t_2} a \cdot dt \right]^{2.5}$$

where a is the resultant acceleration at the centre of gravity of the head (m/s^2) divided by 9,81 recorded versus time and filtered at channel frequency class 1 000 Hz; t_1 and t_2 are any two times between the ► **C1** first and last instants of contact ◀.

2. THORAX PERFORMANCE CRITERIA

2.1. Chest deflection: the peak chest deflection is the maximum value of deflection on any rib as determined by the thorax displacement transducers, filtered at channel frequency class 180 Hz.

2.2. Viscous criterion: the peak viscous response is the maximum value of $V * C$ on any rib which is calculated from the instantaneous product of the relative thorax compression related to the half thorax and the velocity of compression derived by differentiation of the compression, filtered at channel frequency class 180 Hz. For the purposes of this calculation the standard width of the half thorax rib cage is 140 mm.

$$V * C = \text{MAX} \left[\left(\frac{D}{0,140} \right) \cdot \left(\frac{dD}{dt} \right) \right]$$

where D = rib deflection (in m)

The calculation algorithm to be used is set out in Addendum 2 of this appendix.

3. ABDOMINAL PROTECTION CRITERION

The peak abdominal force is the maximum value of the sum of the three forces measured by transducers mounted 39 mm below the surface on the crash side, CFC 600 Hz.

4. PELVIS PERFORMANCE CRITERION

The pubic symphysis peak force (PSPF) is the maximum force measured by a load cell at the pubic symphysis of the pelvis, filtered at channel frequency class 600 Hz.



Appendix 1 — Addendum 2

PROCEDURE FOR CALCULATING THE VISCOUS CRITERION (V*C) FOR SIDE IMPACT DUMMY

The viscous criterion (V*C) is calculated as the instantaneous product of the compression and the rate of deflection of the sternum. Both are derived from the measurement of sternum deflection.

The sternum deflection response is filtered once at channel frequency class 180. The compression at time t is calculated from this filtered signal expressed as the proportion of the half width of the Eurosid 1 chest, measured at the metal ribs (0,14 m):

$$C_{(t)} = \frac{D_{(t)}}{0,14}$$

The sternum deflection velocity at time t is calculated from the filtered deflection as:

$$V_{(t)} = \frac{8 \times (D_{(t+1)} - D_{(t-1)}) - (D_{(t+2)} - D_{(t-2)})}{12 \delta t}$$

where $D_{(t)}$ is the deflection at time t in metres and t is the time interval in seconds between the measurements of deflection. The maximum value of t shall be $1,25 \times 10^{-4}$ seconds. The calculation procedure is shown diagrammatically below:

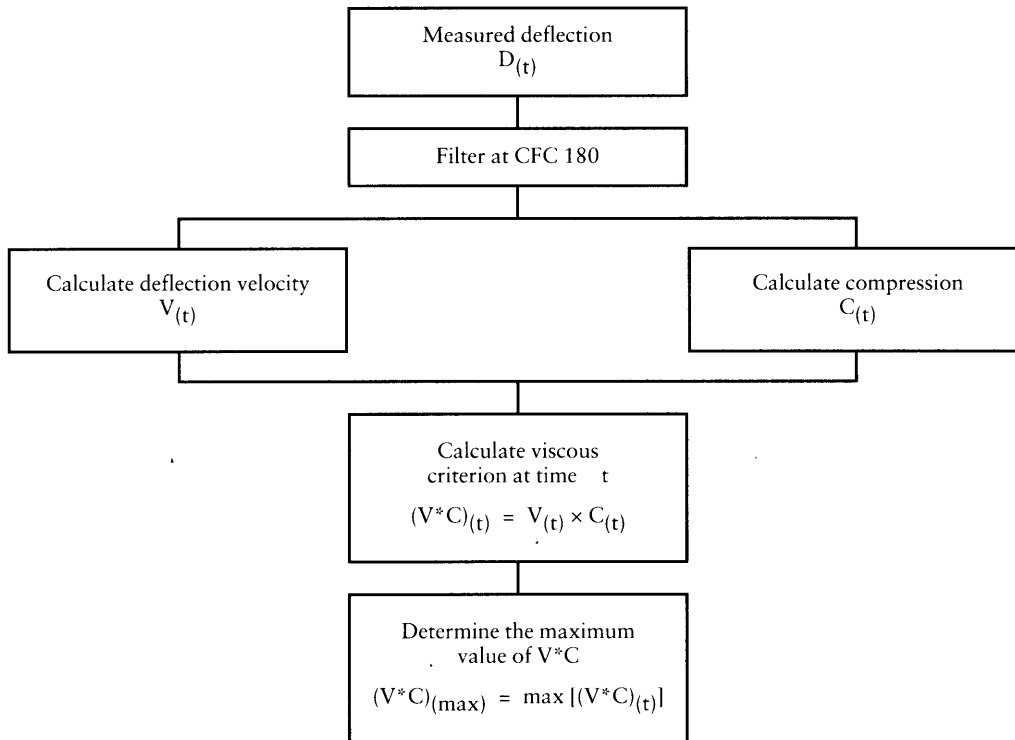



Appendix 2

MOBILE DEFORMABLE BARRIER CHARACTERISTICS

1. CHARACTERISTICS OF THE BARRIER
 - 1.1. The total mass must be 950 ± 20 kg.
 - 1.2. The front and rear track width of the trolley must be $1\,500 \pm 10$ mm.
 - 1.3. The wheel base of the trolley must be $3\,000 \pm 10$ mm.
 - 1.4. The centre of gravity must be situated in the median longitudinal vertical plane within 10 mm, $1\,000 \pm 30$ mm behind the front axle and 500 ± 30 mm above the ground.
 - 1.5. The distance between the front face of the impactor and the centre of gravity of the barrier must be $2\,000 \pm 30$ mm.
2. CHARACTERISTICS OF THE IMPACTOR
 - 2.1. *Geometrical characteristics*
 - 2.1.1. The impactor consists of six independent joined blocks whose forms, sizes and positioning are shown in Figure 1.
 - 2.1.2. The deformable impact zone must be $1\,500 \pm 10$ mm wide and 500 ± 5 mm high.
 - 2.1.3. The ground clearance of the collision zone must be 300 ± 5 mm measured in static conditions before impact, subject to the provisions of Article 4 of this Directive.
 - 2.1.4. There must be six deformable elements, divided into two rows of three elements. All the elements must have the same width (500 ± 5 mm) and the same height (250 ± 3 mm); the elements of the upper row must be 440 ± 5 mm deep and those of the lower row 500 ± 5 mm deep.
 - 2.2. *Material characteristics*

The material of the impactor must be an aluminium honeycomb. Other materials can be used if equal results as described in 2.3 have been proved to the satisfaction of the technical service. In any case the type of impactor must be indicated in the test report.
 - 2.3. *Deformation characteristics*
 - 2.3.1. Deviation from the limits of the force-deflection corridors characterizing the rigidity of the impactor, as defined in this Appendix, Figure 2, may be allowed provided that:
 - 2.3.1.1. the deviation occurs after the beginning of the impact and before the deformation of the impactor is equal to 150 mm;
 - 2.3.1.2. the deviation does not exceed 50 % of the nearest instantaneous prescribed limit of the corridor;
 - 2.3.1.3. each displacement corresponding to each deviation does not exceed 35 mm of the deflection, and the sum of these displacements does not exceed 70 mm (see Figure 2) and
 - 2.3.1.4. the sum of the energy derived from deviating outside the corridor does not exceed 5 % of the gross energy for that block.
 - 2.3.2. Blocks 1 and 3 are identical. Their rigidity is such that their force-deflection curves fall within the hatched area of Figure 2, Graph 2a.
 - 2.3.3. Blocks 5 and 6 are identical. Their rigidity is such that their force-deflection curves fall within the hatched area of Figure 2, Graph 2d.
 - 2.3.4. The rigidity of block 2 is such that its force-deflection curve falls within the hatched area in Figure 2, Graph 2b.
 - 2.3.5. The rigidity of block 4 is such that its force-deflection curve falls within the hatched area of Figure 2, Graph 2c.
 - 2.3.6. The **►C1** force-deflection curve of the impactor **◄** as a whole shall fall within the hatched area of Figure 2, Graph 2e.

▼B

- 2.3.7. The force-deflection curves are verified by a test detailed in the Addendum to this Appendix, consisting of an impact of the assembly against a ►C1 dynamometric barrier ◀ at 35 ± 2 km/h.
- 2.3.8. The dissipated energy⁽¹⁾ against blocks 1 and 3 during the test must equal 10 ± 2 kJ for each of these blocks.
- 2.3.9. The dissipated energy against blocks 5 and 6 must equal $3,5 \pm 1$ kJ for each of these blocks.
- 2.3.10. The dissipated energy against block 4 must equal 4 ± 1 kJ.
- 2.3.11. The dissipated energy against block 2 must equal 14 ± 2 kJ.
- 2.3.12. The total dissipated energy during the impact must equal 45 ± 5 kJ.
- 2.3.13. Impactor deformation measured after the test at level B (Figure 1) must equal ►C1 330 ± 20 mm ◀ .

Figure 1

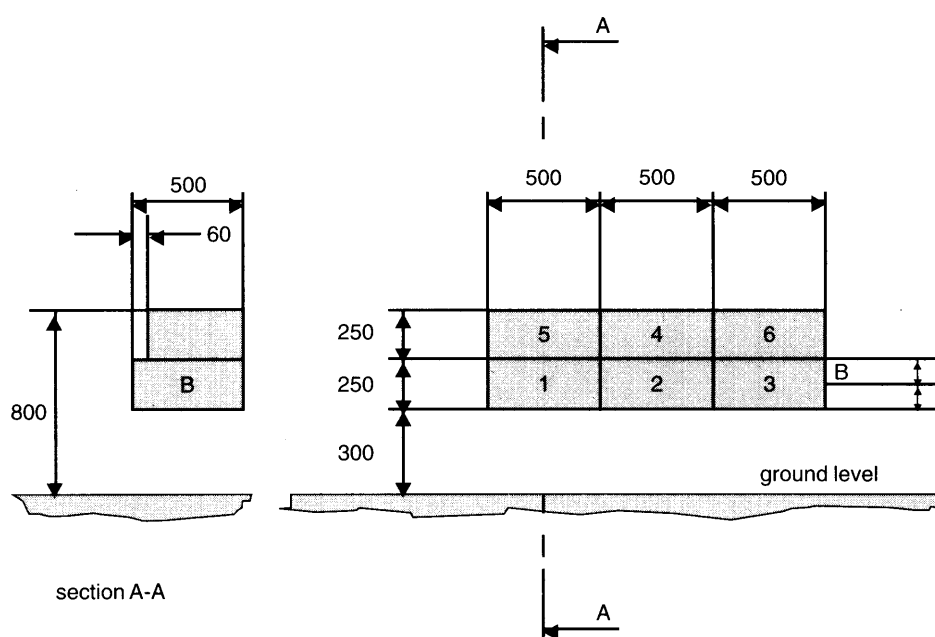
Design of the mobile deformable barrier impactor

⁽¹⁾ The amounts of energy indicated are the amounts of energy dissipated by the system when the extent to which the impactor is crushed is greatest.

▼B

Figure 2

Force-deflection curves

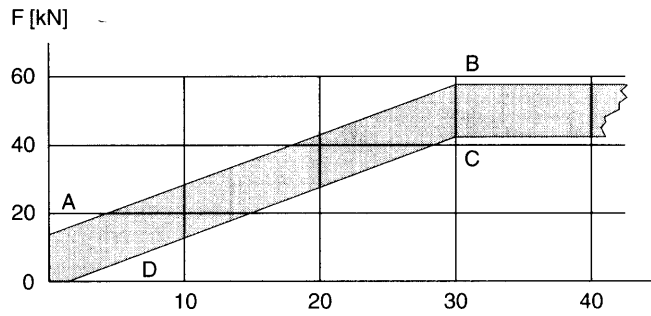

	d	f	
A	0	10	blocks 1 & 3
B	30	58	
C	30	43	
D	3	0	

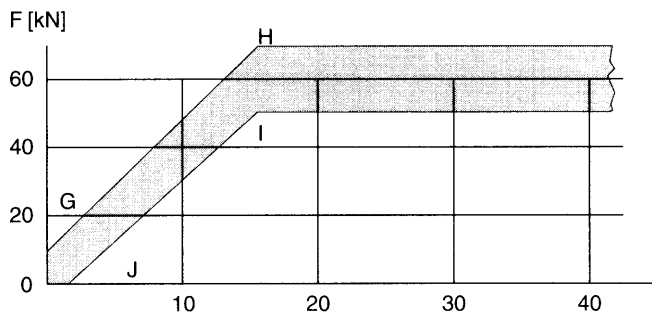

	d	f	
G	0	10	block 2
H	16	70	
I	16	50	
J	3	0	

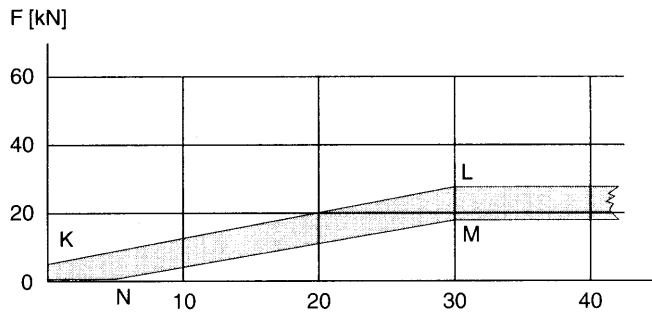

	d	f	
K	5	5	block 4
L	30	28,5	
M	30	18,5	
N	8	0	

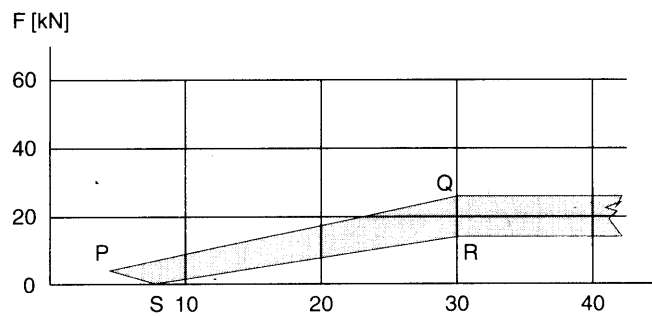

	d	f	
P	5	5	blocks 5 & 6
Q	30	25,5	
R	30	15,5	
S	8	0	

▼B

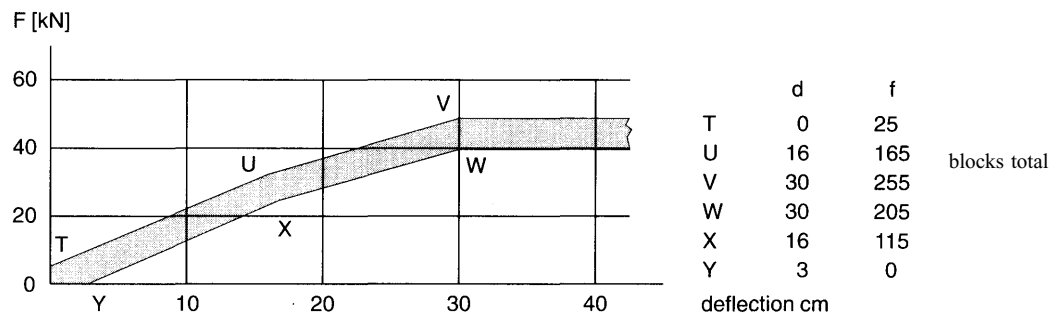

Note: During the verification test, the loads measured on blocks 1 and 3 and on blocks 5 and 6 respectively must not differ by more than 10 % for a given deflection.



Appendix 2 — Addendum

TEST TO VERIFY THE CHARACTERISTICS OF THE MOBILE DEFORMABLE BARRIER

1. PURPOSE

This addendum sets out the method for verifying the mobile deformable barrier. The test authority is responsible for the mobile deformable barrier meeting the specifications using a test against a dynamometric wall supported by a fixed rigid barrier.

2. INSTALLATION

2.1. *Testing ground*

The test area must be large enough to accommodate the run-up track of the mobile deformable barrier, the rigid barrier and the technical equipment necessary for the test. The last part of the track, for at least 5 m before the rigid barrier, must be horizontal, flat and smooth.

2.2. *Fixed rigid barrier and dynamometric wall*

2.2.1. The rigid barrier consists of a block of reinforced concrete not less than 3 m wide in front and not less than 1,5 m high. The thickness of the rigid barrier must be such that it weighs at least 70 tonnes. The front face must be vertical, perpendicular to the axis of the run-up track and covered with load cells capable of measuring the total load on each block of the mobile deformable barrier impactor at the moment of impact. The impact plate area centres must align with those of the chosen mobile deformable barrier; their edges must clear adjacent areas by 20 mm. Cell mounting and plate surfaces must be in accordance with the requirements set out in the Annex to ISO 6487:1987. In cases where surface protection is added, it must not degrade the transducer responses.

2.2.2. The rigid barrier must be either anchored in the ground or placed on the ground with, if necessary, additional arresting devices to prevent its displacement. A rigid barrier with load cells having different characteristics but giving results that are at least equally conclusive may be used.

3. PROPULSION OF THE MOBILE DEFORMABLE BARRIER

At the moment of impact the mobile deformable barrier must no longer be subject to the action of any additional steering or propelling device. It must reach the obstacle on a course perpendicular to the collision barrier. Impact alignment must be accurate to within 10 mm.

4. MEASURING INSTRUMENTS

4.1. *Speed*

The impact speed must be 35 ± 2 km/h. The instrument used to record the speed on impact must be accurate to within 1 %.

4.2. *Loads*

Measuring instruments must meet the specifications set forth in ISO 6487:1987

CFC for all blocks = 60 Hz,

CAC for blocks 1 and 3 = 120 kN,

CAC for blocks 4, 5 and 6 = 60 kN,

CAC for block 2 = 140 kN.

4.3. *Acceleration*

The acceleration in the longitudinal direction must be measured at a place not subject to bending. The instrumentation must comply with ISO 6487:1987 with the following specifications:

CFC: 1 000 Hz (before integration),

CFC: 60 Hz (after integration),

CAC: 50 g.

5. GENERAL SPECIFICATION OF BARRIER

5.1. The individual characteristics of each barrier must comply with Section 1 of Appendix 2 and be recorded.

▼B

6. GENERAL SPECIFICATION OF THE IMPACTOR TYPE
 - 6.1. The suitability of an impactor type is confirmed when the outputs from the six load cells each produce signals complying with the requirements indicated in Section 2.2 of Appendix 2 when recorded.
 - 6.2. Impactors must carry consecutive serial numbers including the date of manufacture.



Appendix 3

TECHNICAL DESCRIPTION OF THE SIDE IMPACT DUMMY

1. GENERAL
 - 1.1. The dimensions and masses of the side impact dummy represent a 50th percentile adult male, without lower arms.
 - 1.2. The side impact dummy consists of a metal and plastic skeleton covered by flesh-simulating rubber, plastic and foam.
 - 1.3. The side impact dummy prescribed in this Directive, including the instrumentation and calibration, is described in technical drawings and a user's manual⁽¹⁾.
2. CONSTRUCTION
 - 2.1. For an overview of the side impact dummy see Figure 1 and Table 1 of this Appendix.
 - 2.2. *Head*
 - 2.2.1. The head is shown as part No 1 in Figure 1 of this Appendix.
 - 2.2.2. The head consists of an aluminium shell covered by a pliable vinyl skin. The interior of the shell is a cavity accommodating triaxial accelerometers and ballast.
 - 2.3. *Neck*
 - 2.3.1. The neck is shown as part No 2 in Figure 1 of this Appendix.
 - 2.3.2. The neck consists of a head/neck interface piece, a neck/thorax interface piece and a central section that links the two interfaces to one another.
 - 2.3.3. The head/neck interface piece (part No 2a) and the neck/thorax interface piece (part No 2c) both consist of two aluminium discs linked together by means of a half spherical screw and eight rubber buffers.
 - 2.3.4. The cylindrical central section (part No 2b) is made of rubber.
 - 2.3.5. The neck is mounted on the neck-bracket, shown as part No 3 in Figure 1 of this Appendix.
 - 2.3.6. ► **C1** The angle between the two faces of the neck-bracket is 25 °. Because the shoulder block is inclined 5 ° backwards, the resulting angle between the neck and torso is 20 °. ◀
 - 2.4. *Shoulder*
 - 2.4.1. The shoulder is shown as part No 4 in Figure 1 of this Appendix.
 - 2.4.2. The shoulder consists of a shoulder block, two clavicles and a shoulder cap.
 - 2.4.3. The shoulder block (part No 4a) consists of an aluminium spacer block, an aluminium plate on top and an aluminium plate on the bottom of the spacer block.
 - 2.4.4. The clavicles (part No 4b) are made of polypropylene. The clavicles are held back in their neutral position by two elastic cords (part No 4c) which are clamped to the rear of the shoulder block. The outer edge of both clavicles accommodates a design allowing for standard arm positions.
 - 2.4.5. The shoulder cap (part No 4d) is made of low-density polyurethane foam and is attached to the shoulder block.
 - 2.5. *Thorax*
 - 2.5.1. The thorax is shown as part No 5 in Figure 1 of this Appendix.
 - 2.5.2. The thorax consists of a rigid thoracic spine box and three identical rib modules.
 - 2.5.3. The thoracic spine box (part No 5a) is made of steel. On the rear surface a lead-filled plastic back plate is mounted (part No 5b).

⁽¹⁾ Until publication of appropriate ISO standards these documents (Eurosid-1 user's manual, dated November 1990) can be obtained from TNO Road Vehicles Research Institute, PO Box 6033, 2600 JA Delft, Schoenmakerstraat 97, 2628 VK Delft, The Netherlands.

▼B

- 2.5.4. The top surface of the thoracic spine box is inclined 5 degrees backwards.
- 2.5.5. A rib module (part No 5c) consists of a steel rib covered by a flesh-simulating polyurethane foam (part No 5d), a piston-cylinder assembly (part No 5e) linking the rib and spine box together, a hydraulic damper (part No 5f) and a stiff damper spring (part No 5g).
- 2.5.6. In the piston-cylinder assembly is a tuning spring (part No 5h).
- 2.5.7. A displacement transducer (part No 5i) can be mounted on the front face of the cylinder and connected to the inside of the rib.
- 2.6. *Arms*
- 2.6.1. The arms are shown as part No 6 in Figure 1 of this Appendix.
- 2.6.2. The arms have a plastic skeleton covered by a polyurethane 'flesh' and a PVC skin.
- 2.6.3. The shoulder/arm joint allows for discrete arm positions at 0°, 40° and 90° to the torso line.
- 2.6.4. The shoulder/arm joint allows for a flexion/extension rotation only.
- 2.7. *Lumbar spine*
- 2.7.1. The lumbar spine is shown as part No 7 in Figure 1 of this Appendix.
- 2.7.2. The lumbar spine consists of a solid rubber cylinder with two steel interface plates at each end, and a steel cable inside the cylinder.
- 2.8. *Abdomen*
- 2.8.1. The abdomen is shown as part No 8 in Figure 1 of this Appendix.
- 2.8.2. The abdomen consists of a metal casting and a polyurethane foam covering.
- 2.8.3. The central part of the abdomen is a metal casting (part No 8a). A cover plate is mounted on top of the casting.
- 2.8.4. The covering (part No 8b) is made of polyurethane foam. A curved slab of rubber filled with ►C1 lead pellets ◀ is integrated in the foam covering at both sides.
- 2.8.5. Between the foam covering and the rigid casting at each side of the abdomen, either three force transducers (part No 8c) or three non-measuring 'dummy' units can be mounted.
- 2.9. *Pelvis*
- 2.9.1. The pelvis is shown as part No 9 in Figure 1 of this Appendix.
- 2.9.2. The pelvis consists of a sacrum block, two iliac wings, two hip joints and a foam covering.
- 2.9.3. The sacrum (part No 9a) consists of a lead-filled aluminium block and an aluminium plate mounted on top of this block.
- 2.9.4. The iliac wings (part No 9b) are made of polyurethane.
- 2.9.5. The hip joints (part No 9c) are made of steel. They consist of an upper femur block and a ball joint connected to an axle passing through the dummy's H point.
- 2.9.6. The flesh system (part No 9d) is made of a PVC skin filled with polyurethane foam. At the H point location the skin is replaced by a large open-cell polyurethane foam cylinder (part No 9e), attached to a steel plate fixed on the iliac wing by an axle going through the ball joint.
- 2.9.7. The iliac wings are linked together at the pubic symphysis by a force transducer (part No 9f) or a 'dummy' transducer.
- 2.10. *Legs*
- 2.10.1. The legs are shown as part No 10 in Figure 1 of this Appendix.
- 2.10.2. The legs consist of a metal skeleton covered by a flesh-simulating polyurethane foam and a plastic skin.
- 2.10.3. The knee and ankle joints allow for a flexion/extension rotation only.
- 2.11. *Suit*
- 2.11.1. The suit is shown as part No 11 in Figure 1 of this Appendix.

▼B

- 2.11.2. The suit is made of rubber and covers the shoulders, thorax, upper part of the arms, the abdomen and lumbar **►C1** spine, and the upper **◄** part of the pelvis.

▼B

Figure 1

Construction of side impact dummy

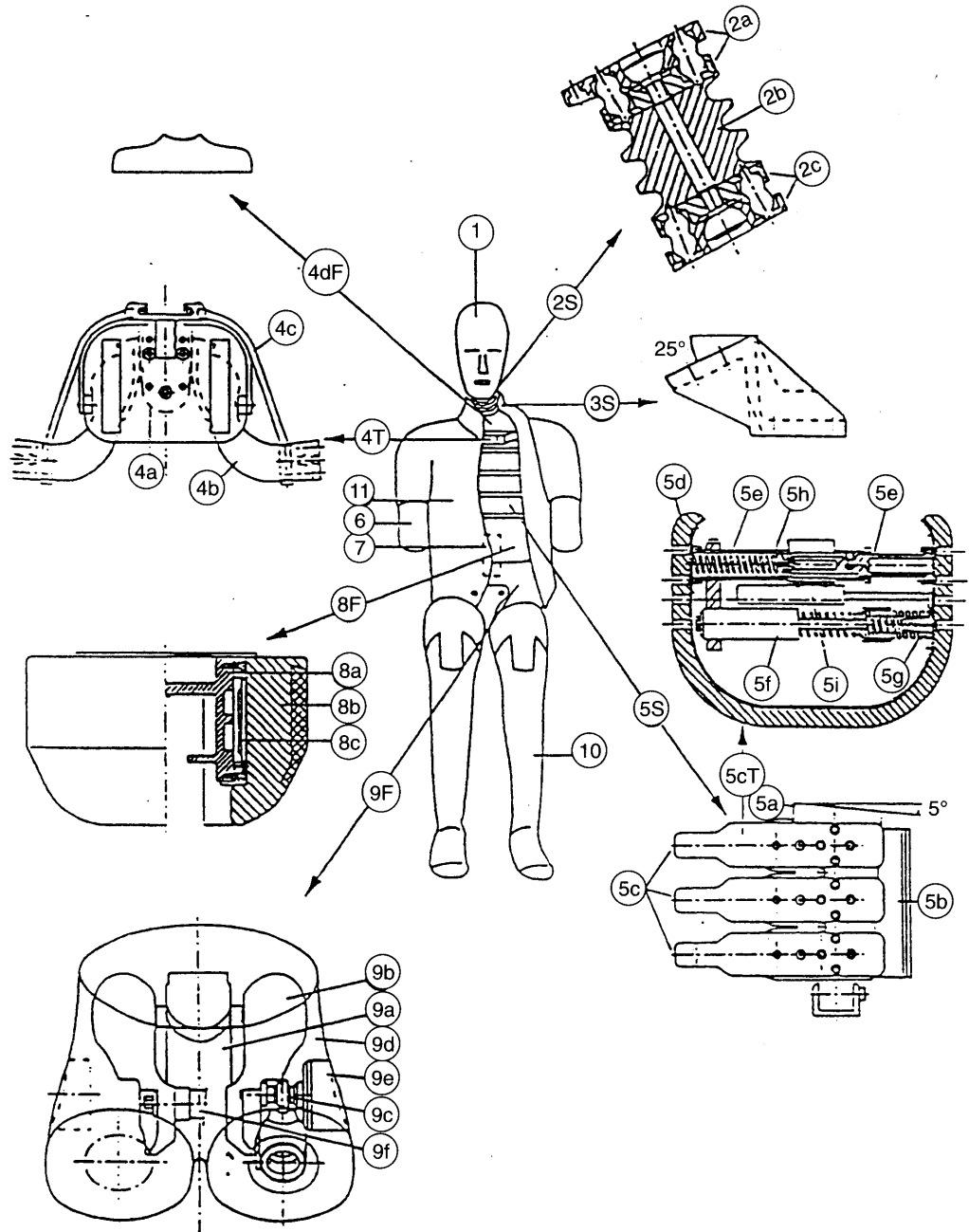



Table 1

Side impact dummy components

Part No	Description	Number
1	Head	1
2	Neck	1
2a	Head/neck interface	1
2b	Central section	1
2c	Neck/thorax interface	1
3	Neck-bracket	1
4	Shoulder	1
4a	Shoulder block	1
4b	Clavicles	2
4c	Elastic cord	2
4d	Shoulder cap	1
5	Thorax	1
5a	Thoracic spine	1
5b	Back plate	1
5c	Rib module	3
5d	Rib covered with flesh	3
5e	Piston-cylinder assembly	3
5f	Damper	3
5g	Damper spring	3
5h	Tuning spring	3
5i	Displacement transducer	3
6	Arm	2
7	Lumbar spine	1
8	Abdomen	1
8a	Central casting	1
8b	Flesh covering	1
8c	Force transducer	3
9	Pelvis	1
9a	Sacrum block	1
9b	Iliac wing	2
9c	Hip joint	2
9d	Flesh covering	1
9e	H point foam block	2
9f	Force transducer	1
10	Leg	2
11	Suit	1

▼B

3. ASSEMBLY OF THE DUMMY
 - 3.1. *Head — neck*
 - 3.1.1. The required torque on the ►C1 hemi-spherical screws ◀ for assembly of the neck is 10 Nm.
 - 3.1.2. The head is mounted to the head-neck interface plate of the neck by three screws.
 - 3.1.3. The neck-thorax interface plate of the neck is mounted to the neck-bracket by four screws.
 - 3.2. *Neck — shoulder — thorax*
 - 3.2.1. The neck-bracket is mounted to the shoulder block by four screws.
 - 3.2.2. The shoulder block is mounted to the top-surface of the thoracic spine box by three screws.
 - 3.3. *Shoulder — arm*
 - 3.3.1. The arms may be mounted to the shoulder clavicles and adjusted by means of a screw and a bearing. The required torque to hold the arm in the defined standard position is 0,6 Nm.
 - 3.4. *Thorax — lumbar spine — abdomen*
 - 3.4.1. A lumbar spine adaptor is mounted by two screws to the lower part of the thoracic spine.
 - 3.4.2. The lumbar spine adaptor is mounted to the top of the lumbar spine by two screws.
 - 3.4.3. The top flange of the central abdominal casting is clamped between the lumbar spine adaptor and the lumbar spine.
 - 3.5. *Lumbar spine — pelvis — legs*
 - 3.5.1. The lumbar spine is mounted to the lumbar spine bottom plate by three screws.
 - 3.5.2. The lumbar spine bottom plate is mounted to the sacrum block of the pelvis by three screws.
 - 3.5.3. The legs are mounted to the upper femur-hip joint of the pelvis by a screw.
 - 3.5.4. The legs may be assembled and adjusted by means of hinge joints in the knees and ankles.
4. MAIN CHARACTERISTICS
 - 4.1. *Mass*
 - 4.1.2. The masses of the main dummy components are shown in Table 2 of this Appendix.



Table 2

Dummy component masses

Component	Mass (kg)	Principal contents
Head	4,0 ± 0,4	Complete head including triaxial accelerometer
Neck	1,0 ± 0,1	Neck, not including neck-bracket
Thorax	22,4 ± 1,5	Neck-bracket, shoulders, arm attachment bolts, spine box, spine back plate, rib modules, rib deflection transducers, lumbar spine adaptor, shoulder cap, abdomen central casting, abdomen force transducers, 2/3 of suit
Arm	1,3 ± 0,1	Upper arm, including arm positioning plate (each)
Abdomen	5,0 ± 0,5	Abdomen flesh covering and lumbar spine
Pelvis	12,0 ± 1,0	Sacrum block, lumbar spine bottom plate, hip ball joints, upper femurs, iliac wings, pubic force transducer, pelvis flesh covering, 1/3 of suit
Leg	12,5 ± 1,0	Foot, lower and upper leg and flesh as far as junction with upper femur (each)
Total	72,0 ± 0,5	

4.2. Principal dimensions

- 4.2.1. The principal dimensions of the side impact dummy (including the suit), based on figure 2 of this Appendix, are given in Table 3 of this Appendix.

Figure 2

Measurements for principal dummy dimensions

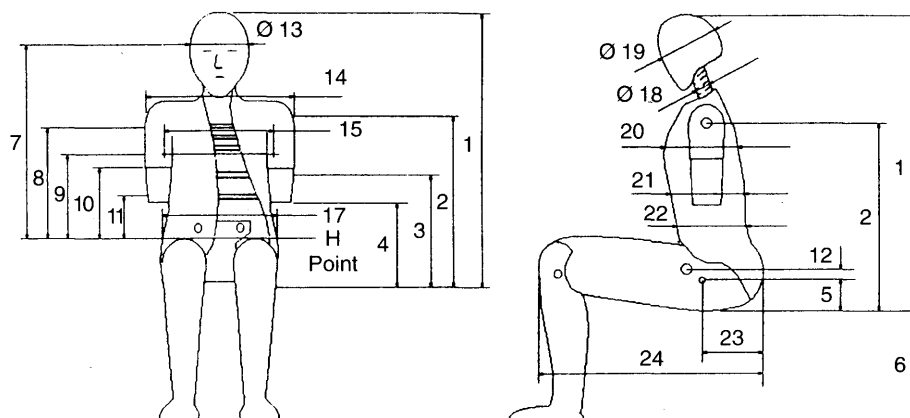



Table 3
Principal dummy dimensions

No	Parameter	Dimension (mm)
1	Sitting height	904 ± 7
2	Seat to shoulder joint	557 ± 5
3	Seat to bottom lower rib	357 ± 5
4	Seat to arm	242 ± 5
5	Seat to H point	98 ± 2
6	Sole to seat, sitting	456 ± 5
7	H point to head C of G	687 ± 5
8	H point to centre upper rib	393 ± 3
9	H point to centre middle rib	337 ± 3
10	H point to centre lower rib	281 ± 3
11	H point to centre abdominal force transducer	180 ± 3
12	H point to centre pubic symphysis force transducer	14 ± 2
13	Head width	154 ± 2
14	Shoulder/arm width	482 ± 5
15	Thorax width	330 ± 5
16	Abdomen width	290 ± 5
17	Pelvis width	355 ± 5
18	Neck diameter	80 ± 2
19	Head depth	201 ± 5
20	Thorax depth	276 ± 5
21	Abdomen depth	204 ± 5
22	Pelvis depth	245 ± 5
23	Back of buttocks to H point	157 ± 2
24	Back of buttocks to front knee	610 ± 5

5. CERTIFICATION OF THE DUMMY

5.1. *Impact side*

- 5.1.1. Depending on the vehicle side to be impacted, dummy parts should be certified on the left hand side or right hand side.
- 5.1.2. The configurations of the rib modules (including instrumentation), the abdominal force transducers and the pubic symphysis transducer must be converted to the required impact side.

5.2. *Instrumentation*

All instrumentation must be calibrated in compliance with the requirements of the documentation specified in 1.3.

- 5.2.1. All instrumentation channels must comply with ISO 6487:1987.

5.3. *Visual check*

- 5.3.1. All dummy parts should be visually checked for damage and if necessary replaced before the certification test.

▼B

5.4. *General test set-up*

- 5.4.1. Figure 3 of this Appendix shows the test set-up for all certification tests on the side impact dummy.
- 5.4.2. The tests on the head, neck, thorax and lumbar spine are carried out on disassembled parts of the dummy.
- 5.4.3. The tests on the shoulder, abdomen and pelvis are performed with the complete dummy (without suit). In these tests the dummy is seated on a flat surface with two sheets of less than, or equal to 2 mm thick Teflon placed between the dummy and the surface.
- 5.4.4. All parts to be certified must be kept in the test room for a period of at least four hours at a temperature between 18 ° and 22 °C prior to a test.
- 5.4.5. The time between two repeated certification tests must be at least 30 minutes.

5.5. *Head*

- 5.5.1. The head is dropped from 200 ± 1 mm on to a flat, rigid impact surface.
- 5.5.2. The angle between the impact surface and the midsagittal plane of the head is $35^\circ \pm 1^\circ$ allowing an impact of the upper side of the head.
- 5.5.3. The peak resultant head acceleration, filtered using CFC 1 000, must be between 100 g and 150 g.
- 5.5.4. The head performance may be adjusted to meet the requirement by altering the friction characteristics of the flesh-skull interface (e.g. by lubrication with talcum powder or PTFE spray).

5.6. *Neck*

- 5.6.1. The head-neck interface of the neck is mounted to a special symmetrical certification headform with a mass of $3,9 \pm 0,05$ kg (see Figure 4).
- 5.6.2. The headform and neck are mounted upside-down to the bottom of a neck-bending pendulum allowing a lateral motion of the system.
- 5.6.3. The neck-pendulum is equipped with a uniaxial accelerometer mounted at $1\,655 \pm 5$ mm from the pendulum pivot.
- 5.6.4. The neck-pendulum must be allowed to fall freely from a height chosen to achieve an impact velocity of $3,4 \pm 0,1$ m/s measured at the accelerometer location.
- 5.6.5. The neck-pendulum is decelerated from impact velocity to zero by an appropriate device, resulting in a deceleration-time history inside the corridor specified in Figure 5 of this Appendix. All channels have to be recorded using ISO CFC 1000 filters and filtered digitally using CFC 60.
- 5.6.6. The maximum headform flexion angle relative to the pendulum must be 51 ± 5 ►C1 degrees and occur after between ◀ 50 and 62 m/s.
- 5.6.7. The maximum headform centre of gravity displacements in the ►C1 lateral and vertical directions ◀ must be 97 ± 10 mm and 26 ± 6 mm respectively.
- 5.6.8. The neck performance may be adjusted by replacing the circular section buffers with buffers of a different ►C1 Shore hardness ◀ .

5.7. *Shoulder*

- 5.7.1. The length of the elastic cord must be adjusted so that a force between 27,5 N and 32,5 N applied in a forward direction 4 ± 1 mm from the outer edge of the clavicle in the same plane as the clavicle movement is required to move the clavicle forward.
- 5.7.2. The dummy is seated on a flat, horizontal, rigid surface with no back support. The thorax is positioned vertically and the arms should be set at an angle of $40^\circ \pm 2^\circ$ forward to the vertical. The legs are positioned horizontally.
- 5.7.3. The impactor is a pendulum of $23,5 \pm 0,2$ kg and 152 ± 2 mm diameter. The impactor is suspended from a rigid support by four wires with the centre line of the impactor at least 3,5 m below the rigid support.
- 5.7.4. The impactor is equipped with an accelerometer sensitive in the direction of impact and located on the impactor axis.
- 5.7.5. The impactor must freely swing on to the shoulder of the dummy with an impact velocity of $4,3 \pm 0,1$ m/s.
- 5.7.6. The impact direction is perpendicular to the anterior-posterior axis of the dummy and the axis of the impactor coincides with the axis of the upper arm pivot.

▼B

- 5.7.7. The peak acceleration of the impactor, filtered using CFC 180, must be between 7,5 and 10,5 g.
- 5.8. *Arms*
- 5.8.1. No dynamic certification procedure is defined for the arms.
- 5.9. *Thorax*
- 5.9.1. Each rib module is certified separately.
- 5.9.2. The rib module is positioned vertically in a drop test rig and the rib cylinder is clamped rigidly on to the rig.
- 5.9.3. The impactor is a free fall mass of ►**CI** 7,8+0 — 0,1 kg ◀ with a flat face and a diameter of 150 ± 2 mm.
- 5.9.4. The centre line of the impactor must be aligned with the centre line of the rib's piston.
- 5.9.5. The impact velocity is 1,0, 2,0, 3,0 and 4,0 m/s respectively. Impact velocities may not vary from those specified by more than 2 %.
- 5.9.6. The rib displacement should be measured, for instance using the rib's own displacement transducer.
- 5.9.7. The rib certification requirements are shown in Table 4 of this Appendix.
- 5.9.8. The performance of the rib module may be adjusted by replacing the tuning spring inside the cylinder with one of a different stiffness.

Table 4

Certification requirements for the full rib module

Impact velocity (m/s)	Displacement (mm)	
	Minimum	Maximum
1,0	10,0	14,0
2,0	23,5	27,5
3,0	36,0	40,0
4,0	46,0	51,0

- 5.10. *Lumbar spine*
- 5.10.1. The lumbar spine is mounted to the special symmetrical certification headform with a mass of $3,9 \pm 0,05$ kg (see Figure 4).
- 5.10.2. The headform and lumbar spine are mounted upside down to the bottom of a neck-bending pendulum allowing a lateral motion of the system.
- 5.10.3. The neck-pendulum is equipped with a uniaxial accelerometer mounted at $1\ 655 \pm 5$ mm from the pendulum pivot.
- 5.10.4. The neck-pendulum is allowed to fall freely from a height chosen to achieve an impact velocity of $6,05 \pm 0,1$ m/s measured at the accelerometer location.
- 5.10.5. The neck-pendulum is decelerated from impact velocity to zero by an appropriate device, resulting in a deceleration-time history inside the corridor specified in Figure 6 of this Appendix. All channels must be recorded using ISO 6487 CFC 1000 filters and filtered digitally using CFC 60.
- 5.10.6. The maximum headform flexion angle relative to the pendulum must be ►**CI** $50 \pm 5^\circ$ and occur after between ◀ 39 and 53 ms.
- 5.10.7. The maximum headform centre of gravity displacements in the lateral and vertical direction must be 104 ± 7 mm and 33 ± 7 mm respectively.
- 5.10.8. The performance of the lumbar spine may be adjusted by changing the length of the spine.
- 5.11. *Abdomen*
- 5.11.1. The dummy is seated on a flat, horizontal, rigid surface with no back support. The thorax is positioned vertically, while the arms and legs are positioned horizontally.

▼B

- 5.11.2. The impactor is a pendulum of $23,5 + \text{►C1 } 0 - 0,2 \text{ kg ◀}$ and 152 ± 2 mm diameter.
- 5.11.3. The pendulum is equipped with a horizontal 'armrest' impactor face of $1,0 \pm 0,01$ kg. The total mass of the impactor with the armrest face is $24,5 + \text{►C1 } 0 - 0,2 \text{ kg ◀}$. The rigid armrest is 70 ± 1 mm high, 150 ± 1 mm wide and should be allowed to penetrate at least 60 mm into the abdomen. The centre line of the pendulum coincides with the centre of the armrest.
- 5.11.4. The impactor is equipped with an accelerometer sensitive in the direction of impact and located on the impactor axis.
- 5.11.5. The impactor must freely swing on to the abdomen of the dummy with an impact velocity of $6,3 \pm 0,1$ m/s.
- 5.11.6. The impact direction is perpendicular to the anterior-posterior axis of the dummy and the axis of the impactor is aligned with the centre of the middle force transducer.
- 5.11.7. The peak force of the impactor, obtained from the impactor acceleration filtered using CFC 180 and multiplied by the impactor/armrest mass, must be between 9,5 and 11,1 kN, and ►C1 occur after between $\text{◀ } 9,8$ and 11,4 ms.
- 5.11.8. The force-time histories measured by the three abdominal force transducers must be summed and filtered using CFC 600. The peak force of this sum must be between 5,9 and 7,9 kN.
- 5.12. *Pelvis*
- 5.12.1. The dummy is seated on a flat, horizontal, rigid surface with no back support. The thorax is positioned vertically while the arms and legs are positioned horizontally.
- 5.12.2. The impactor is a pendulum of $23,5 + \text{►C1 } 0 - 0,2 \text{ kg ◀}$ and 152 ± 2 mm diameter.
- 5.12.3. The impactor is equipped with an accelerometer sensitive in the direction of impact and located on the impactor axis.
- 5.12.4. The impactor must freely swing on to the pelvis of the dummy with an impact velocity of $4,3 \pm 0,1$ m/s.
- 5.12.5. The impact direction is perpendicular to the anterior-posterior axis of the dummy and the axis of the impactor is aligned with the centre of the H point foam cylinder.
- 5.12.6. The peak force of the impactor, obtained from the impactor acceleration filtered using CFC 180 and multiplied by the impactor mass, must be between 4,4 and 5,4 kN, and ►C1 occur after between $\text{◀ } 10,3$ and 15,5 ms.
- 5.12.7. The pubic symphysis force, filtered using CFC 600, must be between 1,04 and 1,64 kN and ►C1 occur after between $\text{◀ } 9,9$ and 15,9 ms.
- 5.13. *Legs*
- 5.13.1. No dynamic certification procedure is defined for the legs.

▼B

Figure 3

Overview of the side impact dummy certification test set-up

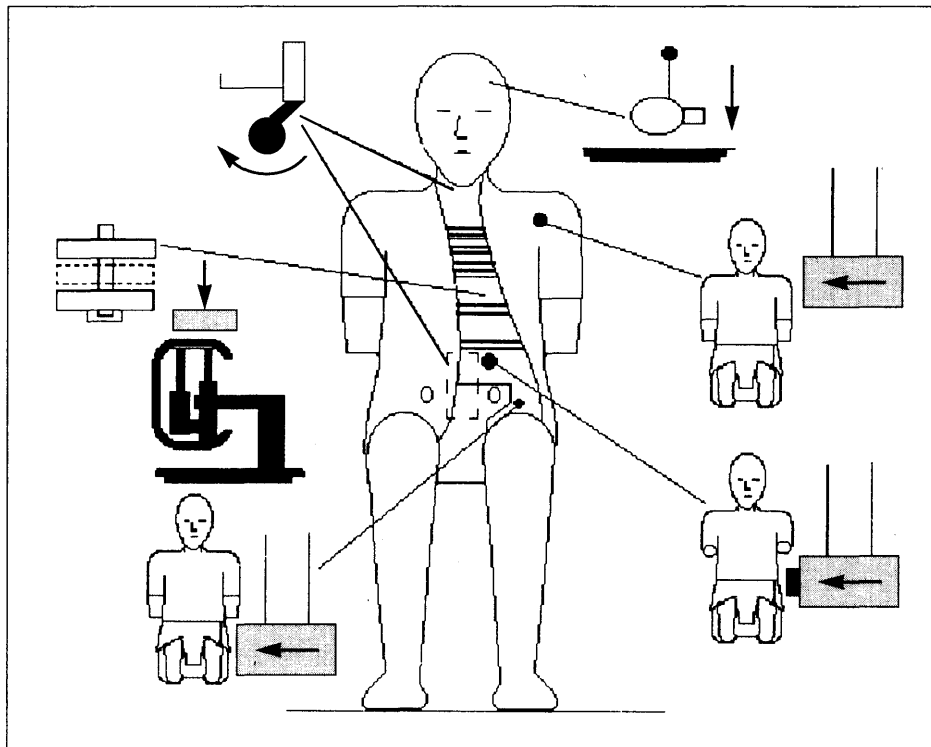
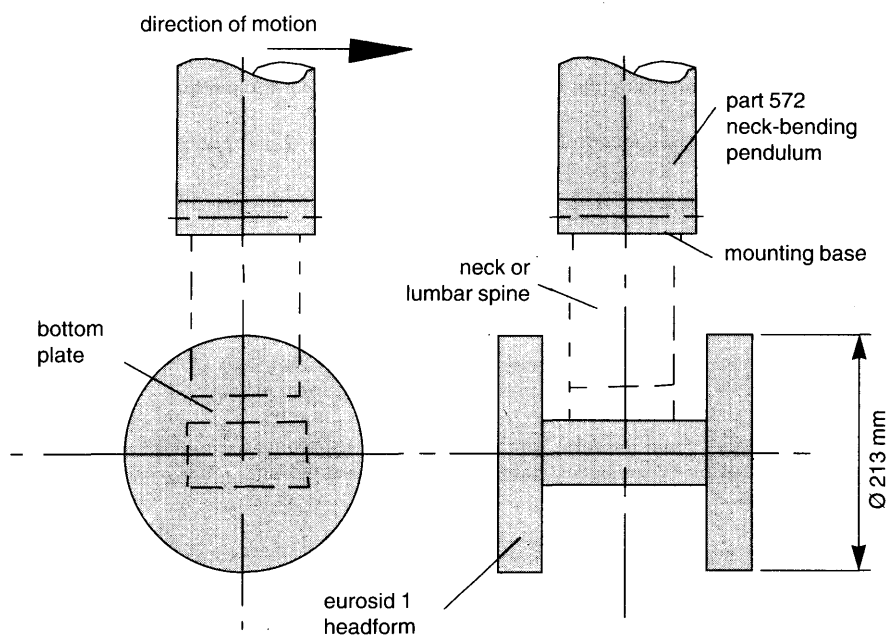

Figure 4

Neck and lumbar spine certification test set-up



▼B

Figure 5

Pendulum deceleration-time corridor for neck certification test

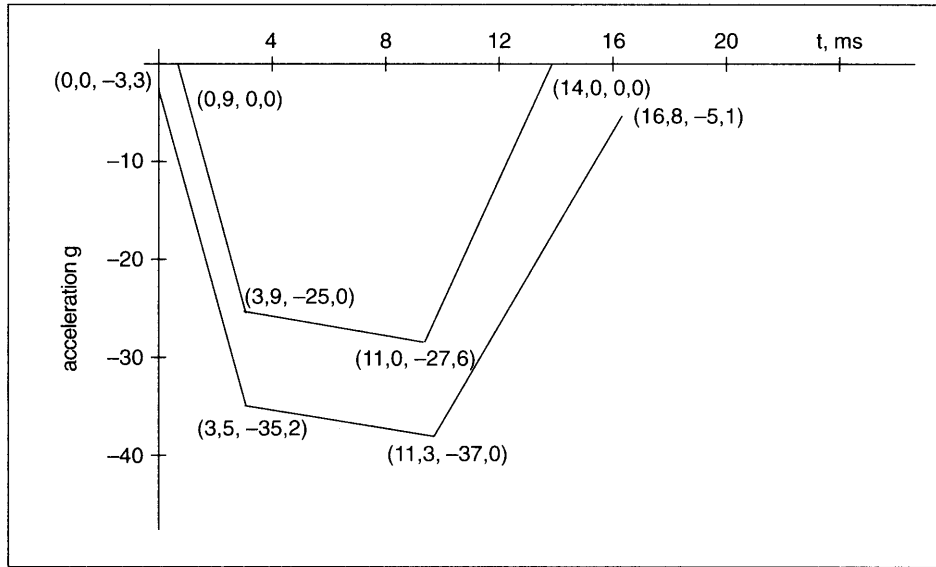
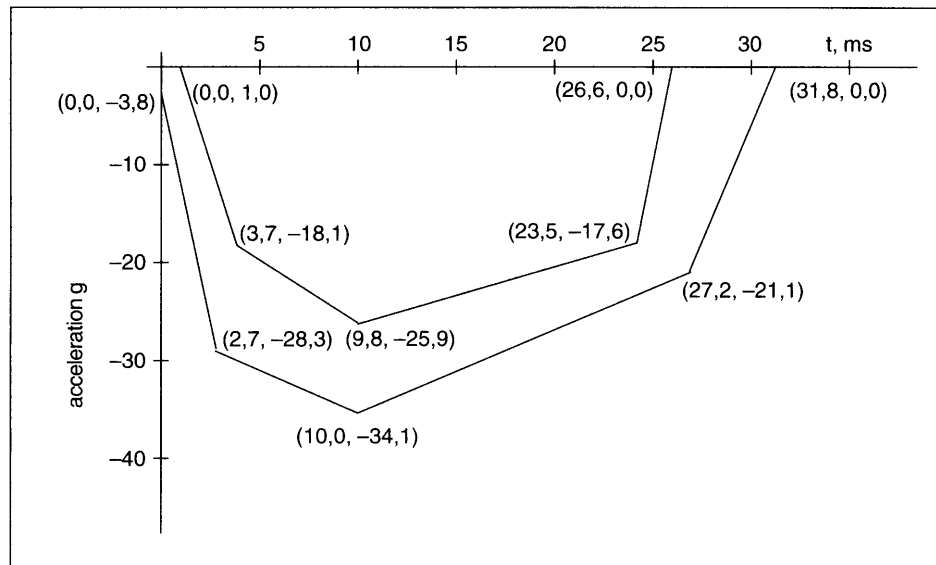

Figure 6

Pendulum deceleration-time corridor for lumbar spine certification test



*Appendix 4***INSTALLATION OF THE SIDE IMPACT DUMMY**

1. GENERAL
 - 1.1. The side impact dummy to be used for the following installation procedure is described in Appendix 3 of Annex II to this Directive.
2. INSTALLATION
 - 2.1. Adjust the leg joints so that they just support the leg when it is extended horizontally (1 to 2 g).
 - 2.2. Clothe the dummy in form-fitting cotton-stretch underwear with short sleeves and mid-calf length trousers. Each foot is equipped with a shoe.
 - 2.3. Place the dummy in the outboard front seat of the impacted side as described in the side impact test procedure specification.
 - 2.4. The plane of symmetry of the dummy must coincide with the median vertical plane of the specified seating position.
 - 2.5. The pelvis of the dummy must be positioned such that a lateral line passing through the dummy H points is perpendicular to the longitudinal centre plane of the seat. The line through the dummy H points must be horizontal with a maximum inclination of $\pm 2^\circ$.
 - 2.6. The upper torso must be bent forward and then laid back firmly against the seat back. The shoulders of the dummy must be set fully rearward.
 - 2.7. Irrespective of the seating position of the dummy, the angle between the upper arm and the torso arm reference line on each side must be $40^\circ \pm 5^\circ$. The torso arm reference line is defined as the intersection of the plane tangential to the front surface of the ribs and the longitudinal vertical plane of the dummy containing the arm.
 - 2.8. For the driver's seating position, without inducing pelvis or torso movement, place the right foot of the dummy on the undepressed accelerator pedal with the heel resting as far forward as possible on the floorpan. Set the left foot perpendicular to the lower leg with the heel resting on the floorpan in the same lateral line as the right heel. Set the knees of the dummy such that their outside surfaces are 150 ± 10 mm from the plane of symmetry of the dummy. If possible within these constraints place the thighs of the dummy in contact with the seat cushion.
 - 2.9. For other seating positions, without inducing pelvis or torso movement, place the heels of the dummy as far forward as possible on the floorpan without compressing the seat cushion more than the compression due to the weight of the leg. Set the knees of the dummy such that their outside surfaces are 150 ± 10 mm from the plane of symmetry of the dummy.



Appendix 5

PARTIAL TEST

1. PURPOSE

The purpose of these tests is to verify whether the modified vehicle presents at least the same (or better) energy absorption characteristics than the vehicle type-approved under this Directive.
2. PROCEDURES AND INSTALLATIONS
 - 2.1. *Reference tests*
 - 2.1.1. Using the initial padding materials tested during the type-approval of the vehicle, mounted in a new lateral structure of the vehicle to be approved, two dynamic tests, utilizing two different impactors are carried out (Figure 1).
 - 2.1.1.1. The head form impactor, defined in 3.1.1, must hit at 24,1 km/h, in the area impacted for the Eurosid head during the approval of the vehicle. Test results must be recorded, and the HPC calculated. ►C1 However, this test is not carried out ◀ when, during the tests described in Appendix 1 to Annex II to this Directive:
 - there has been no head contact, or
 - the head contacted window glazing only, provided that the window glazing is not laminated glass.
 - 2.1.1.2. The body block impactor, defined in 3.2.1, must hit at 24,1 km/h in the lateral area impacted by the Eurosid shoulder, arm and ►C1 thorax during ◀ the type-approval of the vehicle. Test results must be recorded, and the HPC calculated.
 - 2.2. *Type-approval test*
 - 2.2.1. Using the new padding materials, seat, etc. submitted for the type-approval extension, and mounted in a new lateral structure of the ►C1 vehicle, the tests specified in 2.1.1.1 and 2.1.1.2 are ◀ repeated, the new results recorded, and their HPC calculated.
 - 2.2.1.1. If the HPC calculated from the results of both approval tests are lower than the HPC obtained during the reference tests (carried out using the original type-approved padding materials or seats), the extension is granted.
 - 2.2.1.2. If the new HPC are greater than the HPC obtained during the reference test, a new full scale test (using the proposed padding/seats/etc.) is carried out.
 3. TEST EQUIPMENT
 - 3.1. *Head form impactor (Figure 1)*
 - 3.1.1. This apparatus consists of a fully guided linear impactor, rigid, with a mass of 6,8 kg. Its impact surface is hemispherical with a diameter of 165 mm.
 - 3.1.2. The head form must be fitted with two accelerometers and a speed-measuring device, all capable of measuring values in the impact direction.
 - 3.2. *Body block impactor (Figure 1)*
 - 3.2.1. This apparatus consists of a fully guided linear impactor, rigid, with a mass of 30 kg. Its dimensions and transversal section are shown in Figure 1.
 - 3.2.2. The body block must be fitted with two accelerometers and a speed-measuring device, all capable of measuring values in the impact direction.

▼B

Figure 1

