

II

(Acts whose publication is not obligatory)

COUNCIL

COUNCIL DIRECTIVE 93/92/EEC

of 29 October 1993

on the installation of lighting and light-signalling devices on two or three-wheel motor vehicles

THE COUNCIL OF THE EUROPEAN COMMUNITIES,

Having regard to the Treaty establishing the European Economic Community, and in particular Article 100a thereof,

Having regard to Directive 92/61/EEC of 30 June 1992 on the type-approval of two or three-wheel motor vehicles (1),

Having regard to the proposal from the Commission (2),

In cooperation with the European Parliament (3),

Having regard to the opinion of the Economic and Social Committee (4),

Whereas in each Member State the lighting and light-signalling devices fitted to two or three-wheel vehicles must display certain technical characteristics laid down by mandatory provisions which differ from one Member State to the other; whereas, as a result of their differences, such provisions constitute a barrier to trade within the Community;

Whereas these barriers to the operation of the internal market may be removed if the same requirements are adopted by all Member States in place of their national rules;

Whereas it is necessary to draw up harmonized requirements concerning the fitting of lighting and light-signalling devices in order to enable the type-approval procedure laid down in Directive 92/61/EEC to be applied for each of such vehicle;

Whereas in order to facilitate access to the markets of non-Community countries it would seem necessary to establish equivalence as far as two-wheel motorcycles are concerned, between the requirements of this Directive and those of Regulation No 53 of the United Nations Economic Commission for Europe,

HAS ADOPTED THIS DIRECTIVE:

Article 1

This Directive applies to the installation of lighting and light-signalling devices on all types of vehicle as defined in Article 1 of Directive 92/61/EEC.

Article 2

The procedure governing the granting of component type-approval in respect of the installation of lighting and light-signalling devices on a type of two or three-wheel motor vehicle and the conditions governing the free movement of such vehicles shall be as laid down in Directive 92/61/EEC.

Article 3

In accordance with Article 11 of Directive 92/61/EEC, equivalence between the requirements laid down in this

(1) OJ No L 225, 10. 8. 1992, p. 72.

(2) OJ No C 93, 13. 4. 1992, p. 39.

(3) OJ No C 305, 23. 11. 1992, p. 115 and Decision of 27 October 1993 (not yet published in the Official Journal).

(4) OJ No C 313, 30. 11. 1992, p. 7.

Directive for two-wheel motorcycles and those laid down in United Nations ECE Regulation No 53 (E/ECE/TRANS/505-Add.61/Amend. 1) is hereby acknowledged.

The authorities of the Member States which grant component type-approval shall accept approvals granted in accordance with the requirements of the abovementioned Regulation No 53 as well as component type-approval marks as an alternative to the corresponding approvals granted in accordance with the requirements of this Directive.

Article 4

Any amendments necessary in order to adapt Annexes I to VI to technical progress shall be adopted in accordance with the procedure laid down in Article 13 of Directive 70/156/EEC (1).

Article 5

Member States which, in their national law concerning the installation of stop lamps on two-wheel mopeds, specify requirements which are less stringent than those laid down in this Directive, may continue to apply those requirements for a maximum period of three years from the implementation date of this Directive.

Article 6

1. Member States shall adopt and publish the provisions necessary to comply with this Directive not later than 1 May 1995. They shall forthwith inform the Commission thereof.

When the Member States adopt these provisions, they shall contain a reference to this Directive or shall be accompanied by such a reference on the occasion of their official publication. The methods of making such a reference shall be laid down by the Member States.

From the date mentioned in the first subparagraph Member States may not, for reasons connected with the installation of lighting and light-signalling devices, prohibit the initial entry into service of vehicles which conform to this Directive.

They shall apply the provisions referred to in the first subparagraph as from 1 November 1995.

2. Member States shall communicate to the Commission the texts of the provisions of national law which they adopt in the fields covered by this Directive.

Article 7

This Directive is addressed to the Member States.

Done at Brussels, 29 October 1993.

For the Council

The President

R. URBAIN

(1) (OJ No L 42, 23. 2. 1970, p. 1, as last amended by Directive 92/53/EEC (OJ No L 225, 10. 8. 1992, p. 1).

LIST OF ANNEXES

ANNEX I:	Definitions and general requirements	4
Appendix 1:	Lamp surfaces, axis and centre of reference and angles of geometric visibility	10
Appendix 2:	Definition of lamp colours	11
ANNEX II:	Requirements applying to two-wheel mopeds	12
Appendix 1:	Visibility of red lights towards the front and white lights towards the rear	20
Appendix 2:	Arrangement drawing	21
Appendix 3:	Information document in respect of the installation of lighting and light-signalling devices on a type of two-wheel moped	22
Appendix 4:	Certificate of component type approval in respect of the installation of lighting and light-signalling devices on a type of two-wheel moped	23
ANNEX III:	Requirements applying to three-wheel mopeds and light quadricycles	24
Appendix 1:	Visibility of red lights towards the front and white lights towards the rear	32
Appendix 2:	Arrangement drawing	33
Appendix 3:	Information document in respect of the installation of lighting and light-signalling devices on a type of three-wheel moped	34
Appendix 4:	Certificate of component type approval in respect of the installation of lighting and light-signalling devices on a type of three-wheel moped	35
ANNEX IV:	Requirements applying to two-wheel motor cycles	36
Appendix 1:	Visibility of red lights towards the front and white lights towards the rear	45
Appendix 2:	Arrangement drawing	46
Appendix 3:	Information document in respect of the installation of lighting and light-signalling devices on a type of two-wheel motor cycle	47
Appendix 4:	Certificate of component type approval in respect of the installation of lighting and light-signalling devices on a type of two-wheel motor cycle	48
ANNEX V:	Requirements applying to motor cycles with side-car	49
Appendix 1:	Visibility of red lights towards the front and white lights towards the rear	58
Appendix 2:	Arrangement drawing	59
Appendix 3:	Information document in respect of the installation of lighting and light-signalling devices on a type of motor cycles with side-car	60
Appendix 4:	Certificate of component type approval in respect of the installation of lighting and light-signalling devices on a type of motor cycles with side-car	61
ANNEX VI:	Requirements applying to tricycles	62
Appendix 1:	Visibility of red lights towards the front and white lights towards the rear	72
Appendix 2:	Arrangement drawing	73
Appendix 3:	Information document in respect of the installation of lighting and light-signalling devices on a type of tricycle	74
Appendix 4:	Certificate of component type approval in respect of the installation of lighting and light-signalling devices on a type of tricycle	75

ANNEX I

DEFINITIONS AND GENERAL REQUIREMENTS

A. DEFINITIONS

For the purposes of this Directive:

1. *vehicle type*

with regard to the installation of lighting and light-signalling devices means vehicles which do not differ in such essential respects as:

 - 1.1. the dimensions and outer shape of the vehicle;
 - 1.2. the number and positioning of the devices;
 - 1.3. the following are, likewise, considered not to be 'vehicles of a different type':
 - 1.3.1. vehicles which differ within the meaning of 1.1 and 1.2 below, but not in such a way as to entail a change in the type, number, positioning and geometric visibility of the lamps prescribed for the vehicle type in question;
 - 1.3.2. vehicles on which optional lamps component type-approved by virtue of a Directive are fitted or are absent;
2. *transverse plane*

means a vertical plane perpendicular to the median longitudinal plane of the vehicle;
3. *unladen vehicle*

means the vehicle without a driver, passenger or load, but with a full complement of fuel and its normal on-board tool kit;
4. *device*

means a component or combination of components used in order to perform one or several functions;
5. *lamp*

means a device designed to illuminate the road or to emit a light signal to other road users. Rear registration plate lamps and retro reflectors are likewise regarded as lamps;

 - 5.1. *single lamp*

means a device or part of a device, having one function and one illuminating surface and one or more light sources. For the purpose of installation on a vehicle, a 'single lamp' also means any assembly of two independent or grouped lamps, whether identical or not, having the same function, if they are installed such that the projections of the illuminating surfaces of the lamps on a given transverse plane occupy not less than 60 % of the smallest rectangle circumscribing the projections of the said illuminating surfaces. In such a case, each of these lamps is, where approval is required, to be approved as a type 'D' lamp.
 - 5.2. *equivalent lamps*

means lamps having the same function and authorized in the country in which the vehicle is registered; such lamps may have different characteristics from those installed on the vehicle when it is approved on condition that they satisfy the requirements of this Annex;
 - 5.3. *independent lamps*

means lamps having separate illuminating surfaces, light sources and lamp bodies;

- 5.4. *grouped lamps*
means lamps having separate illuminating surfaces and light sources, but a common lamp body;
- 5.5. *combined lamps*
means lamps having separate illuminating surfaces but a common light source and a common lamp body;
- 5.6. *reciprocally incorporated lamps*
means devices having separate light sources or a single light source operating under different conditions (e. g. optical, mechanical or electrical differences), totally or partially common illuminating surfaces and a common lamp body;
- 5.7. *main-beam headlamp*
means the lamp used to illuminate the road over a long distance ahead of the vehicle;
- 5.8. *dipped-beam headlamp*
means the lamp used to illuminate the road ahead of the vehicle without causing undue dazzle or discomfort to oncoming drivers or to other road users;
- 5.9. *direction indicator lamp*
means the lamp used to indicate to other road users that the driver intends to change direction to the right or the left;
- 5.10. *stop lamp*
means the lamp used to indicate to other road users to the rear of the vehicle that the latter's driver is applying the service brake;
- 5.11. *front position lamp*
means the lamp used to indicate the presence of the vehicle when viewed from the front;
- 5.12. *rear position lamp*
means the lamp used to indicate the presence of the vehicle when viewed from the rear;
- 5.13. *front fog lamp*
means the lamp used to improve the illumination of the road in case of fog, snowfall, rainstorms or dust clouds;
- 5.14. *rear fog lamp*
means the lamp used to render the vehicle more readily visible from the rear in dense fog;
- 5.15. *reversing lamp*
means the lamp used to illuminate the road to the rear of the vehicle and to warn other road users that the vehicle is reversing or about to reverse;
- 5.16. *hazard warning signal*
means the simultaneous operation of all of a vehicle's direction indicator lamps to draw attention to the fact that the vehicle temporarily constitutes a special danger to other road users;
- 5.17. *rear registration plate lamp*
means the device used to illuminate the space intended to accommodate the rear registration plate; it may consist of several optical elements;

- 5.18. *retro reflector*
- means the device used to indicate the presence of a vehicle by the reflection of light emanating from a light source not connected to the vehicle, the observer being situated near that source; for the purposes of this Annex retro-reflecting number plates are not considered to be retro reflectors;
6. *illuminating surface* (see Appendix 1)
- 6.1. *light-emitting surface* of a lighting device or retro reflector means all or part of the exterior surface of the translucent material as declared in the request for approval by the manufacturer of the device on the drawing (see Appendix 1);
- 6.2. *illuminating surface of a lighting device* (see 5.7, 5.8, 5.13 and 5.15)
- means the orthogonal projection of the full aperture of the reflector or in the case of headlamps with an ellipsoidal reflector of the projection lens, on a transverse plane. If the lighting device has no reflector, the definition of 6.3 is applied. If the light-emitting surface of the lamp extends over part only of the full aperture of the reflector, then the projection of that part only is taken into account. In the case of a dipped-beam headlamp, the illuminating surface is limited by the apparent trace of the cut-off on to the lens. If the reflector and lens are adjustable relative to one another, the mean adjustment is used.
- 6.3. *illuminating surface of a light-signalling device other than a retro-reflector* (see 5.9 to 5.12, 5.14, 5.16 and 5.17)
- means the orthogonal projection of the lamp in a plane perpendicular to its axis of reference and in contact with the exterior light-emitting surface of the lamp, this projection being bounded by the edges of screens situated in this plane, each allowing only 98 % of the total luminous intensity of the light to persist in the direction of the axis of reference; to determine the lower, upper and lateral limits of the illuminating surface, only screens with horizontal or vertical edges are used;
- 6.4. *illuminating surface of a retro reflector* (5.18)
- means the orthogonal projection of a retro reflector in a plane perpendicular to its axis of reference and bounded by planes touching the outer edges of the light projection surface of the retro reflector and parallel to this axis. To determine the lower, upper and lateral limits of the illuminating surface, only horizontal and vertical planes are used;
7. *apparent surface*
- for a defined direction of observation means, at the request of the manufacturer or his duly accredited representative, the orthogonal projection of either:
- the boundary of the illuminating surface projected on the exterior surface of the lens (a-b), or
 - the light-emitting surface (c-d),
- in a plane perpendicular to the direction of observation and tangential to the most exterior point of the lens (see drawings at Appendix 1);
8. *axis of reference*
- means the characteristic axis of the lamp, determined by the manufacturer (of the lamp) for use as the direction of reference ($H = 0^\circ$, $V = 0^\circ$) for angles of field for photometric measurements and when fitting the lamp on the vehicle;
9. *centre of reference or reference centre*
- means the intersection of the axis of reference with the light-emitting surface, the centre of reference being specified by the lamp manufacturer;
10. *angles of geometric visibility*
- means the angles which determine the field of the minimum solid angle in which the apparent surface of the lamp must be visible. That field is determined by the segments of the sphere of

which the centre coincides with the centre of reference of the lamp and the equator is parallel with the ground. These segments are determined in relation to the axis of reference. The horizontal angles correspond to the longitude and the vertical angles to the latitude. There must be no obstacle on the inside of the angles of geometric visibility to the propagation of light from any part of the apparent surface of the lamp observed from infinity.

If measurements are taken closer to the lamp, there must be a parallel shift in the direction of observation to achieve the same accuracy. No account is taken of obstacles on the inside of the angles of geometric visibility, if they were already present when the lamp was type-approved.

If, when the lamp is installed, any part of the apparent surface of the lamp is hidden by any further parts of the vehicle, proof must be furnished that the part of the lamp not hidden by obstacles still conforms to the photometric values prescribed for the approval of the device as an optical unit (see Appendix 1);

11. *extreme outer edge*

on either side of the vehicle means the plane parallel to the median longitudinal plane of the vehicle and coinciding with its lateral outer edge, disregarding the projection(s) of:

11.1. the rear-view mirrors;

11.2. the direction indicator lamps;

12. *overall width*

means the distance between the two vertical planes defined in section 11;

13. *distance between two lamps pointing in the same direction*

means the distance between the orthogonal projections, in a plane perpendicular to the axes of reference, of the outlines of the two illuminating surfaces as defined, according to the case, in section 6;

14. *operational telltale*

means the telltale showing whether a device that has been actuated is operating correctly or not;

15. *circuit-closed telltale*

means a telltale showing that a device has been switched on but not showing whether it is operating correctly or not.

B. GENERAL SPECIFICATIONS

1. The lighting and light-signalling devices must be so installed that under normal conditions of use and notwithstanding any vibration to which they may be subjected, they retain the characteristics laid down and enable the vehicle to comply with the requirements of this Directive. In particular, it must not be possible for the adjustment of the lamps to be inadvertently disturbed.

2. The illuminating lamps must be so fitted that their alignment can easily be set correctly.

3. For all light-signalling devices the reference axis of the lamp when fitted to the vehicle must be perpendicular to the median longitudinal plane of the vehicle in the case of side retro reflectors and parallel to that plane in the case of all other signalling devices. In each direction a tolerance of 3° is allowed.

In addition, any specific instructions as regards fitting laid down by the manufacturer must be complied with.

4. The height and alignment of lamps are checked, in the absence of specific instructions, with the vehicle unladen and located on a flat horizontal surface; with its median longitudinal plane being vertical and its handlebars or steering wheel in the dead-ahead position. The tyre pressure must be that specified by the manufacturer for the specific loading conditions laid down.
5. In the absence of specific requirements, lamps constituting a pair must:
 - 5.1. be installed on the vehicle symmetrically in relation to the median longitudinal plane;
 - 5.2. be symmetrical to each other in relation to the median longitudinal plane;
 - 5.3. fulfil the same colorimetric requirements;
 - 5.4. have substantially identical photometric characteristics.
6. In the absence of specific instructions, lamps having different functions may be independent or be grouped, combined or reciprocally incorporated in one device, provided that each such lamp complies with the requirement applicable to it.
7. The maximum height above ground is measured from the highest point, and the minimum height from the lowest point, of the illuminating surface. The minimum height above ground of dipped-beam headlamps must be measured from the lower edge of the lens, or of the reflector if the latter is higher.
8. In the absence of specific requirements no lamps other than direction indicator lamps and the hazard warning signal may emit a flashing light.
9. No red lamp must be visible towards the front and no white lamp other than any reversing lamp fitted visible towards the rear. This condition is checked as follows (see drawings according to the types of two or three-wheel vehicles set out in Appendice 1 to Annexes II to VI):
 - 9.1. for the visibility of a red lamp towards the front: there must be no direct visibility of a red lamp if viewed by an observer moving within Zone 1 in a transverse plane situated 25 m in front of the foremost part of the vehicle;
 - 9.2. for the visibility of a white lamp towards the rear: there must be no direct visibility of a white lamp if viewed by an observer moving within Zone 2 in a transverse plane situated 25 m behind the rearmost part of the vehicle;
 - 9.3. Zones 1 and 2, as seen by the observer, are limited in their respective planes as follows:
 - 9.3.1. as regards height, two horizontal planes which are 1 m and 2.2 m respectively above the ground;
 - 9.3.2. as regards width, by two vertical planes making an angle of 15° towards the front and rear respectively, and outside the vehicle by reference to the median longitudinal plane of the vehicle. These planes contain, respectively, the vertical lines of intersection of the vertical planes parallel to the longitudinal median plane of the vehicle and representing its overall width, and of the transverse planes representing the overall length of the vehicle.
10. The electrical connections must be such that the front position lamp or the dipped-beam headlamp, if there is no front position lamp, the rear position lamp and the rear registration plate lamp can only be switched on and off simultaneously.
11. In the absence of specific requirements, the electrical connections must be such that the main-beam headlamp, the dipped-beam headlamp and the fog lamp cannot be switched on until the lamps referred to in section 10 have also been switched on. This requirement does not apply, however, to main-beam or dipped-beam headlamps when their optical warnings consist of the intermittent lighting up at short intervals of the main-beam headlamp, or the intermittent lighting up at short intervals of the dipped-beam headlamp, or the alternate lighting up at short intervals of the main-beam and dipped-beam headlamps.
12. Telltales
 - 12.1. All telltales must be clearly visible to the driver in the normal driving position.

12.2. Where provision has been made for a circuit-closed telltale it may be replaced by an operational telltale.

13. **Colours emitted by the lamps:**

The colours emitted by the lamps are as follows:

Main-beam headlamps:	white
Non-triangular front retro-reflector:	white
Dipped-beam headlamp:	white
Direction-indicator lamp:	amber
Stop lamp:	red
Front position lamp:	white
Rear position lamp:	red
Front fog lamp:	white/yellow
Rear fog lamp:	red
Reversing lamp:	white
Hazard warning signal:	amber
Rear registration plate lamp:	white
Non-triangular side retro-reflector:	amber
Non-triangular rear retro-reflector:	red
Pedal retro-reflector:	amber

The definition of lamp colours must be as laid down in Appendix 2.

14. All lighting and light-signalling devices must be component type-approved. However, pending the entry into force of harmonized provisions concerning lighting and light-signalling devices on mopeds with engines of no more than 0,5 kW and a maximum speed not exceeding 25 km/h, such mopeds may be fitted with dipped-beam headlamps and/or rear position lamps which have not been approved. In such cases, the manufacturer must declare that the devices concerned conform to ISO standard 6742/1. Specific additional requirements will be laid down in accordance with the procedure outlined in Article 13 of Directive 70/156/EEC.

Appendix 1

Lamp surfaces, axis and centre of reference, and angles of geometric visibility

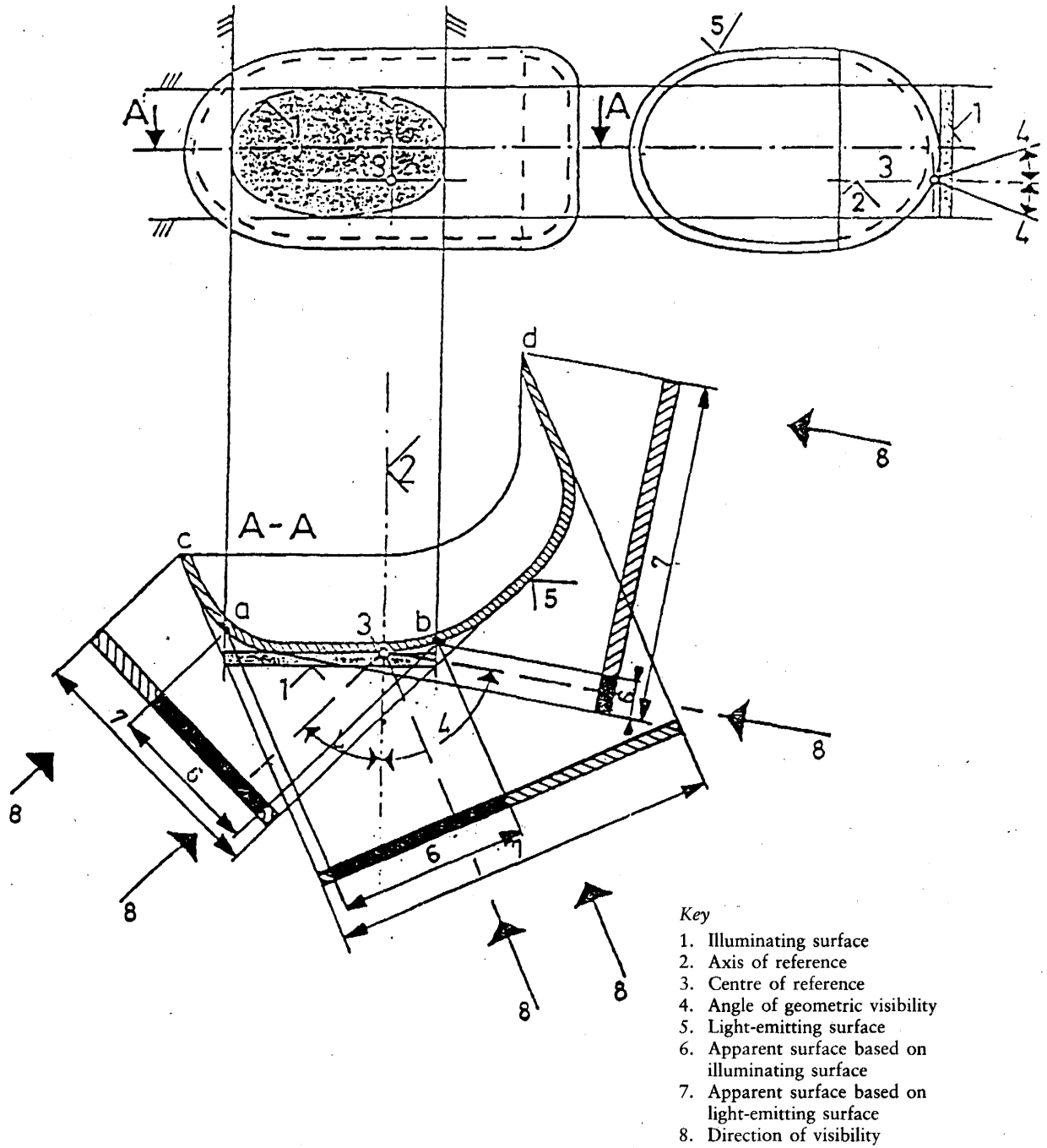

NB: Notwithstanding the drawing the apparent surface is to be considered as tangent to the light-emitting surface.

Appendix 2

Definition of lamp colours

TRICHROMATIC COORDINATES

Red	Limit towards yellow: Limit towards purple:	$y \leq 0,335$ $z \leq 0,008$
White	Limit towards blue: Limit towards yellow: Limit towards green: Limit towards green: Limit towards purple: Limit towards red:	$x \geq 0,310$ $x \leq 0,500$ $y \leq 0,150 + 0,640x$ $y \leq 0,440$ $y \geq 0,050 + 0,750x$ $y \geq 0,382$
Yellow	Limit towards red: Limit towards green: Limit towards white: Limit towards the spectral value:	$y \geq 0,138 + 0,580x$ $y \leq 1,29x - 0,100$ $y \leq -x + 0,940$ $y \leq 0,440$ $y \leq -x + 0,992$
Amber	Limit towards yellow: Limit towards red: Limit towards white:	$y \leq 0,429$ $y \geq 0,398$ $z \leq 0,007$

A source having a colour temperature of 2 856 K is used to check the above limits (International Commission on Illumination (ICI) Standard A).

ANNEX II

REQUIREMENTS CONCERNING TWO-WHEEL MOPEDS

1. Without prejudice to the provisions of Section B 14 of Annex I, all two-wheel mopeds must be fitted with the lighting and light-signalling devices listed below:
 - 1.1. dipped-beam headlamp;
 - 1.2. rear position lamp;
 - 1.3. stop lamp. This requirement does not apply to mopeds covered by an exemption such as that provided for in Annex I, section B 14;
 - 1.4. non-triangular rear retro-reflectors;
 - 1.5. non-triangular rear retro-reflectors;
 - 1.6. pedal retro-reflectors only where two-wheel mopeds are fitted with non-retractable pedals.
2. In addition all two-wheel mopeds may be fitted with the following lighting and light-signalling devices:
 - 2.1. main-beam headlamp;
 - 2.2. direction indicator lamps;
 - 2.3. rear registration plate lamp;
 - 2.4. front position lamp;
 - 2.5. non-triangular front retro-reflectors.
3. Each of the lighting and light-signalling devices referred to in sections 1 and 2 must be fitted to comply with the appropriate provisions of section 6 below.
4. No lighting and light-signalling device other than those referred to in sections 1 and 2 above may be fitted.
5. Lighting and light-signalling devices type-approved for motorcycles and referred to in sections 1 and 2 may also be fitted to mopeds.

6. SPECIFIC FITTING REQUIREMENTS

6.1. Main-beam headlamps

6.1.1. *Number:* one or two6.1.2. *Arrangement drawing:* no individual specifications6.1.3. *Location*

6.1.3.1. Width:

- an independent main-beam headlamp may be fitted above or below or to one side of another front lamp: if these lamps are one on top of the other the reference centre of the main-beam headlamp must be located within the median longitudinal plane of the vehicle; if these lamps are side by side their reference centre must be symmetrical in relation to the median longitudinal plane of the vehicle,
- a main-beam headlamp that is reciprocally incorporated with another front lamp must be fitted in such a way that its reference centre lies within the median longitudinal plane of the vehicle; however, when the vehicle is also fitted with an independent dipped-beam headlamp alongside the main-beam headlamp their reference centres must be symmetrical in relation to the median longitudinal plan of the vehicle,
- two main-beam headlamps of which either one or both are reciprocally incorporated with another front lamp must be fitted in such a way that their reference centres are symmetrical in relation of the median longitudinal plane of the vehicle.

- 6.1.3.2. The length: at the front of the vehicle. This requirement is considered to have been met if the light emitted does not disturb the driver either directly or indirectly by means of the rear-view mirrors and/or reflective surfaces on the vehicle.
- 6.1.3.3. In any case, the distance between the edge of the illuminating surface of any independent main-beam headlamp and the edge of that of the dipped-beam headlamp must not exceed 200 mm.
- 6.1.3.4. The distance separating the illuminating surfaces of two main-beam headlamps must not exceed 200 mm.
- 6.1.4. *Geometrical visibility*
- Even in the zones which do not seem to be illuminated in the direction of observation under consideration, the illuminating surface must be visible within a divergent area limited by generatrices touching the entire contour of the illuminating surface and forming an angle of 5° at least with the headlamp reference axis. The contour of the projection of the illuminating surface on to a transverse plane that is tangent to the front part of the main-beam headlamp lens is considered to be the origin of the angles of geometrical visibility.
- 6.1.5. *Alignment: forwards*
- May pivot along with the steering angle.
- 6.1.6. May be grouped together with the dipped-beam headlamp and the front position lamp.
- 6.1.7. May not be combined with any other lamp.
- 6.1.8. May be reciprocal, incorporated:
- 6.1.8.1. with the dipped-beam headlamp;
- 6.1.8.2. with the front position lamp.
- 6.1.9. *Electrical connections*
- The main-beam headlamps must light simultaneously. All main-beam headlamps must light when they are switched from dipped-beam to main-beam. All main-beam headlamps must be extinguished simultaneously when switched from main-beam to dipped-beam. The dipped-beam headlamps may remain lit at the same time as the main-beam headlamps.
- 6.1.10. *Circuit-closed telltale: optional.*
- Blue non-flashing warning light.
- 6.2. **Dipped-beam headlamps**
- 6.2.1. *Number: one or two.*
- 6.2.2. *Arrangement drawing: no individual specifications.*
- 6.2.3. *Position*
- 6.2.3.1. *Width:*
- an independent dipped-beam headlamp may be installed above, below or to one side of another front lamp: if these lamps are one above the other the reference centre of the dipped-beam headlamp must be located in the median longitudinal plane of the vehicle; if these lamps are side by side their reference centres must be symmetrical in relation to the median longitudinal plane of the vehicle,
 - a dipped-beam headlamp that is reciprocally incorporated with another front lamp must be installed in such a way that its reference centre lies within the median longitudinal plane of the vehicle. However, where the vehicle is also fitted with an independent main-beam headlamp alongside the dipped-beam headlamp their reference centres must be symmetrical in relation to the median longitudinal plane of the vehicle,
 - two dipped-beam headlamps, of which either one or both are reciprocally incorporated with another front lamp must be installed in such a way that their reference centres are symmetrical in relation to the median longitudinal plane of the vehicle.
- 6.2.3.2. *Height: a minimum of 500 mm and a maximum of 1 200 mm above the ground.*

- 6.2.3.3. Length: at the front of the vehicle this requirement is regarded as satisfied if the light emitted does not cause discomfort to the driver either directly or indirectly by means of the rear-view mirrors and/or other reflecting surfaces of the vehicle.
- 6.2.3.4. In the case of two dipped-beam headlamps the distance separating the illuminating surfaces must not exceed 200 mm.
- 6.2.4. *Geometric visibility*
Determined by angles α and β as specified in section A 10 of Annex I:
 $\alpha = 15^\circ$ upwards and 10° downwards;
 $\beta = 45^\circ$ to the left and to the right if there is only one dipped-beam headlamp.
 45° outwards and 10° inwards if there are two dipped-beam handlamps.
The presence of panels or other items of equipment near the light must not give rise to secondary effects causing discomfort or other road users.
- 6.2.5. *Alignment forwards*
May move in line with the steering angle.
- 6.2.6. May be grouped together with the main-beam headlamp and the front position lamp.
- 6.2.7. May not be combined with any other lamps.
- 6.2.8. May be reciprocally incorporated with the main-beam headlamp and the front position lamp.
- 6.2.9. *Electrical connections*
The control for changing over the dipped beam must switch off all main-beam headlamps simultaneously, whereas the dipped beams may remain switched on at the same time as the main beam.
- 6.2.10. *Circuit-closed telltale*: optional.
Green non-flashing indicator light.
- 6.2.11. *Other requirements*: none.
- 6.3. **Direction indicator lamps**
- 6.3.1. Two per side.
- 6.3.2. *Arrangement drawing*: two front and two rear indicator lamps.
- 6.3.3. *Position*
- 6.3.3.1. Width:
- 6.3.3.1.1. The following apply simultaneously to front indicator lamps:
- 6.3.3.1.1.1. there must be a minimum distance of 240 mm between the illuminating surfaces;
- 6.3.3.1.1.2. they must be situated outside the vertical longitudinal planes that are tangent to the outer edges of the illuminating surfaces of the headlamp(s).
- 6.3.3.1.1.3. A minimum distance between the illuminating surfaces of the indicators and the closest dipped-beam headlamps of:
- 75 mm in the case of a minimum indicator intensity of 90 cd,
 - 40 mm in the case of a minimum indicator intensity of 175 cd,
 - 20 mm in the case of a minimum indicator intensity of 250 cd,
 - ≤ 20 mm in the case of a minimum indicator intensity of 400 cd.
- 6.3.3.1.2. The distance between the inner edges of the illuminating surfaces of the rear indicator lamps must be at least 180 mm.
- 6.3.3.2. Height: minimum 350 mm, maximum 1 200 mm above the ground.
- 6.3.3.3. Length: the distance towards the front between the transverse plane corresponding to the extreme longitudinal rearmost extremity of the vehicle and the centre of reference of the rear indicators must not exceed 300 mm.
- 6.3.4. *Geometric visibility*
Horizontal angles: see Appendix 2.
Vertical angles: 15° above and below the horizontal.

However, the vertical angle below the horizontal may be reduced to 5° if the lamps are less than 750 mm above the ground.

6.3.5. *Alignment*

The direction indicator lamps may move in line with the steering angle.

6.3.6. May be grouped with one or more lamps.

6.3.7. May not be combined with any other lamp.

6.3.8. May not be reciprocally incorporated with another lamp.

6.3.9. *Electrical connections*

Direction indicator lamps must switch on independently of the other lamps. All direction indicator lamps on one side of a vehicle must be switched on and off by means of one control.

6.3.10. *Operational telltale: optional.*

It may be optical or auditory or both. If it is optical it must be a green flashing light and visible under all normal operating conditions. It must be extinguished or remain alight without flashing or show a marked change of frequency in the event of the malfunction of any of the direction indicator lamps. If it is entirely auditory it must be clearly audible and show the same operating conditions as the optical telltale.

6.3.11. *Other requirements*

The characteristics listed below must be measured with the electrical generator supplying current only to those circuits that are essential to the operation of the engine and lighting devices.

6.3.11.1. Actuation of the light-signalling device control must be followed by illumination of the lamp within a maximum of one second and extinction of the first lamp within a maximum of one a half seconds.

6.3.11.2. In the case of all vehicles the direction indicator lamps of which are supplied with direct current:

6.3.11.2.1. the flashing-light frequency must be 90 ± 30 times per minute;

6.3.11.2.2. the direction indicator lamps on the same side of the vehicle must flash at the same frequency and in phase.

6.3.11.3. Where a vehicle is fitted with direction indicator lamps which are supplied with alternating current, when the engine speed lies between 50 and 100 % of the speed corresponding to the maximum speed of the vehicle:

6.3.11.3.1. the lights must flash at a frequency of 90 ± 30 times per minute;

6.3.11.3.2. the direction indicator lamps may flash on the same side of the vehicle either simultaneously or alternately. The front lamps must not be visible to the rear nor the rear lamps to the front within the zones defined in Appendix 1.

6.3.11.4. Where the direction indicator lamps fitted to a vehicle are supplied with alternating current, when the engine speed lies between the idling speed specified by the manufacturer and 50 % of the speed corresponding to the maximum speed of the vehicle:

6.3.11.4.1. the flashing frequency must lie between $90 + 30$ and $90 - 45$ times per minute;

6.3.11.4.2. direction indicator lamps on the same side of the vehicle may flash either simultaneously or alternately. The front lamps must not be visible to the rear, nor the rear lamps visible to the front within the zones defined in Appendix 1.

6.3.11.5. In the event of failure, other than a short circuit, of one direction indicator lamp, the other must continue to flash, or remain lit, but the frequency in this state may be different from that specified.

6.4. *Stop lamps*

6.4.1. *Number: one or two.*

6.4.2. *Arrangement drawing: no individual specifications.*

6.4.3. *Position*

- 6.4.3.1. Width: if there is only one stop lamp its centre of reference must lie within the median longitudinal plane of the vehicle, or if there are two stop lamps they must be symmetrical to the median longitudinal plane of the vehicle.
- 6.4.3.2. Height: minimum 250 mm, maximum 1 500 mm above ground.
- 6.4.3.3. Length: at the rear of the vehicle.
- 6.4.4. *Geometric visibility*
Horizontal angle: 45° to the left and to the right.
Vertical angle: 15° above and below the horizontal.
However, the vertical angle below the horizontal may be reduced to 5° if the lamp is less than 750 mm above the ground.
- 6.4.5. *Alignment*: towards the rear of the vehicle.
- 6.4.6. May be grouped with one or more other rear lamps.
- 6.4.7. May not be combined with another lamp.
- 6.4.8. May be reciprocally incorporated with the rear position lamp.
- 6.4.9. *Operational electrical connection*: must light up whenever at least one of the service brakes is applied.
- 6.4.10. *Circuit-closed telltale*: prohibited.
- 6.5. **Front position lamps**
- 6.5.1. *Number*: one or two.
- 6.5.2. *Arrangement drawing*: no individual specifications.
- 6.5.3. *Position*
- 6.5.3.1. Width:
— one independent front position lamp may be fitted above or below or to one side of another front lamp: if these lamps are one above the other the reference centre of the front position lamp must be located within the median longitudinal plane of the vehicle; if these lamps are side by side their reference centres must be symmetrical in relation to the median longitudinal plane of the vehicle,
— a front position lamp that is reciprocally incorporated with another front lamp must be installed in such a way that its reference centre is situated in the median longitudinal plane of the vehicle,
— two front position lamps one or both of which is/are reciprocally incorporated with another front lamp must be installed in such a way that their reference centres are symmetrical in relation to the median longitudinal plane of the vehicle.
- 6.5.3.2. Height: minimum 350 mm, maximum 1 200 mm above the ground.
- 6.5.3.3. Length: at front of vehicle.
- 6.5.4. *Geometric visibility*
Horizontal angle: 80° to the left and to the right if there is a single position lamp; 80° to the outside and 45° towards the inside if there are two position lamps.
Vertical angle: 15° above and below the horizontal. However, the vertical angle below the horizontal may be reduced to 5° if the lamp is less than 750 mm above the ground.
- 6.5.5. *Alignment*: towards the front.
May pivot as a function of the steering angle.
- 6.5.6. May be grouped with any other front lamp.
- 6.5.7. May be reciprocally incorporated with any other front lamp.
- 6.5.8. *Operational electrical connections*: no individual specifications.
- 6.5.9. *Circuit-closed telltale*: optional.
Non-flashing green indicator light.
- 6.5.10. Other requirements: none.

- 6.6. **Rear position lamps**
- 6.6.1. *Number*: one or two.
- 6.6.2. *Arrangement drawing*: no individual specifications.
- 6.6.3. *Position*
- 6.6.3.1. Width: the reference centre must be located within the median longitudinal plane of the vehicle if there is only one position lamp, or if there are two position lamps these must be symmetrical to the median longitudinal plane of the vehicle.
- 6.6.3.2. Height: minimum 250 mm, maximum 1 500 mm above the ground.
- 6.6.3.3. Length: at rear of vehicle.
- 6.6.4. *Geometric visibility*
- Horizontal angle: 80° to the left and to the right if there is a single position lamp; 80° towards the outside and 45° towards the inside if there are two position lamps.
- Vertical angle: 15° above and below the horizontal. However, the vertical angle below the horizontal may be reduced to 5° if the lamp is less than 750 mm above the ground.
- 6.6.5. *Alignment*: towards the rear.
- 6.6.6. May be grouped with any other rear lamp.
- 6.6.7. May be reciprocally incorporated with the stop lamp or non-triangular rear retro reflector, or with both.
- 6.6.8. *Operational electric connections*: no individual specification.
- 6.6.9. *Circuit-closed telltale*: optional.
- Its function may be fulfilled by the device provided, where appropriate, for the front position lamp.
- 6.6.10. *Other requirements*: none.
- 6.7. **Non-triangular side retro-reflectors**
- 6.7.1. *Number per side*: one or two class IA ⁽¹⁾.
- 6.7.2. *Arrangement drawing*: no individual specifications.
- 6.7.3. *Position*
- 6.7.3.1. Width: no individual specifications.
- 6.7.3.2. Height: 300 mm minimum, 900 mm maximum above the ground.
- 6.7.3.3. Length: should be such that, under normal conditions, the device cannot be masked by the driver or passenger, nor by their clothing.
- 6.7.4. *Geometric visibility*
- Horizontal angles: 30° towards the front and rear.
- Vertical angles: 15° above and below the horizontal.
- However, the vertical angle below the horizontal may be reduced to 5° if the reflector is less than 750 mm above the ground.
- 6.7.5. *Alignment*: the reference axis of the reflectors must be perpendicular to the median longitudinal plane of the vehicle and point towards the rear. The front reflectors may pivot in line with the steering angle.
- 6.7.6. May be grouped with other signalling devices.
- 6.8. **Non-triangular rear retro-reflectors**
- 6.8.1. *Number*: one class IA ⁽¹⁾.
- 6.8.2. *Arrangement drawing*: no individual specifications.

⁽¹⁾ In accordance with the classification set out in Directive 76/757/EEC.

- 6.8.3. *Position*
- 6.8.3.1. Width: the reference centre must be located within the median longitudinal plane of the vehicle.
- 6.8.3.2. Height: minimum 250 mm, maximum 900 mm above the ground.
- 6.8.3.3. Length: at rear of vehicle.
- 6.8.4. *Geometric visibility*
- Horizontal angle: 30° to the left and right.
- Vertical angle: 15° above and below the horizontal.
- However, the vertical angle below the horizontal may be reduced to 5° if the reflector is less than 750 mm above the ground.
- 6.8.5. *Alignment*: towards the rear.
- 6.8.6. May be grouped with any other lamp.
- 6.8.7. *Other requirements*: the illuminating surface of the reflector may have parts in common with any other rear-mounted red lamp.
- 6.9. **Pedal retro-reflectors**
- 6.9.1. Each pedal of a two-wheel moped must be fitted with two retro-reflectors.
- 6.9.2. *Arrangement drawing*: no individual specification.
- 6.9.3. *Other requirements*
- The illuminating surface of the retro reflector must be recessed within its frame. The reflectors must be installed within the body of the pedal in such a way that they are clearly visible both to the front and to the rear of the vehicle. The reference axis of the reflectors, the shape of which must be adapted to that of the body of the pedal, and put at right angles to the axis of the pedal. The pedal reflectors need be mounted only on vehicle pedals which, by means of cranks or similar devices, may act as a means of propulsion instead of the engine. They need not be mounted on pedals acting as vehicle controls or solely as footrests for the driver or passenger.
- 6.10. **Non-triangular front retro-reflector**
- 6.10.1. *Number*: 1 of Class IA ⁽¹⁾.
- 6.10.2. *Arrangement drawing*: no individual specification.
- 6.10.3. *Position*
- 6.10.3.1. Width: the reference centre must be located within the median longitudinal plane of the vehicle;
- 6.10.3.2. Height: minimum 400 mm, maximum 1 200 mm above the ground;
- 6.10.3.3. Length: at front of vehicle.
- 6.10.4. *Geometric visibility*
- Horizontal angle: 30° to the left and right
- Vertical angle: 15° above and below the horizontal.
- However, the vertical angle below the horizontal may be reduced to 5° if the reflector is less than 750 mm above the ground.
- 6.10.5. *Alignment*: towards the front. May pivot in line with the steering angle.
- 6.10.6. May be grouped with one or more lamps.
- 6.10.7. *Other specifications*: none.

(1) In accordance with the classification set out in Directive 76/757/EEC.

6.11. **Rear registration plate lamp**6.11.1. *Number: one.*

The lamp may consist of several optical elements intended to illuminate the position of the plate.

6.11.2. *Arrangement drawing*6.11.3. *Position*6.11.3.1. *Width:*6.11.3.2. *Height:*6.11.3.3. *Length:*6.11.4. *Geometrical visibility*6.11.5. *Position*

} Such that the lamp illuminates the position reserved for the registration plate.

6.11.6. *May be grouped with one or more rear lamps.*6.11.7. *May be combined with the rear position lamp.*6.11.8. *May not be reciprocally incorporated with any other lamp.*6.11.9. *Operational electrical connections: no individual specifications:*6.11.10. *Circuit-closed telltale: optional.*

Its operation must be ensured by the same telltale as provided for the position lamp.

6.11.11. *Other requirements: none.*

Appendix 1

Visibility of red lights towards the front and white lights towards the rear

(See point B.9 in Annex I and point 6.3.11.4.2 in this Annex)

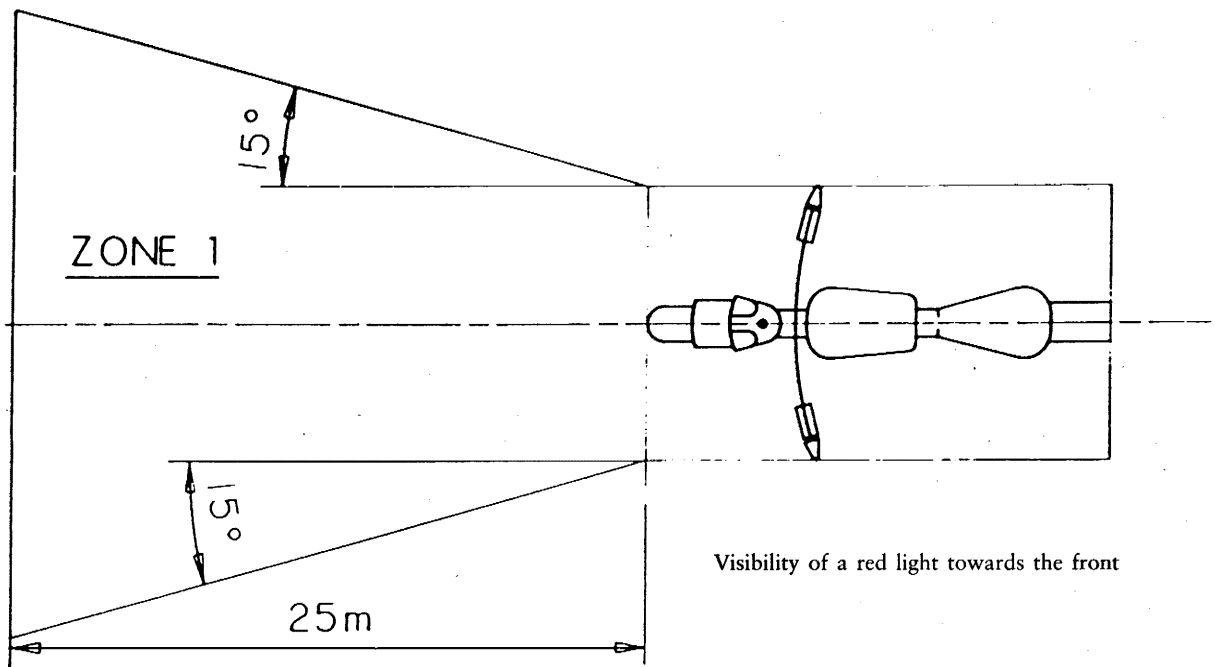

Visibility of a red light towards the front

Figure 1

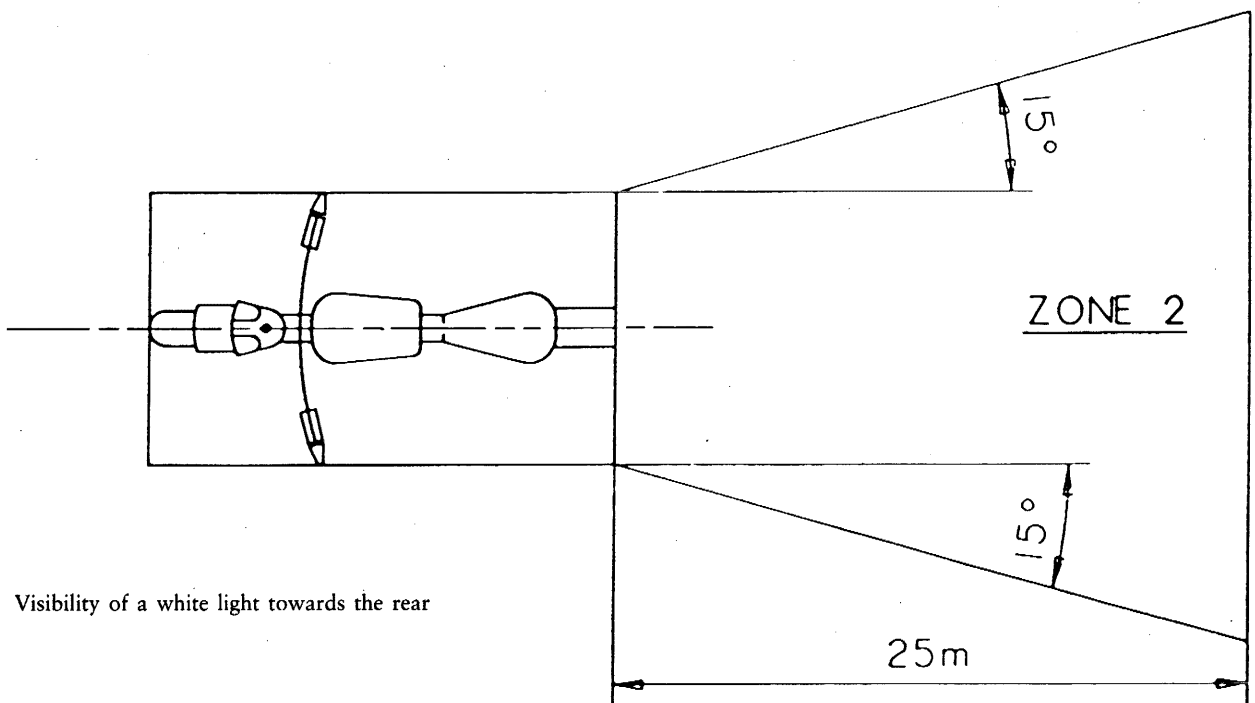

Visibility of a white light towards the rear

Figure 2

Appendix 2

Arrangement drawing

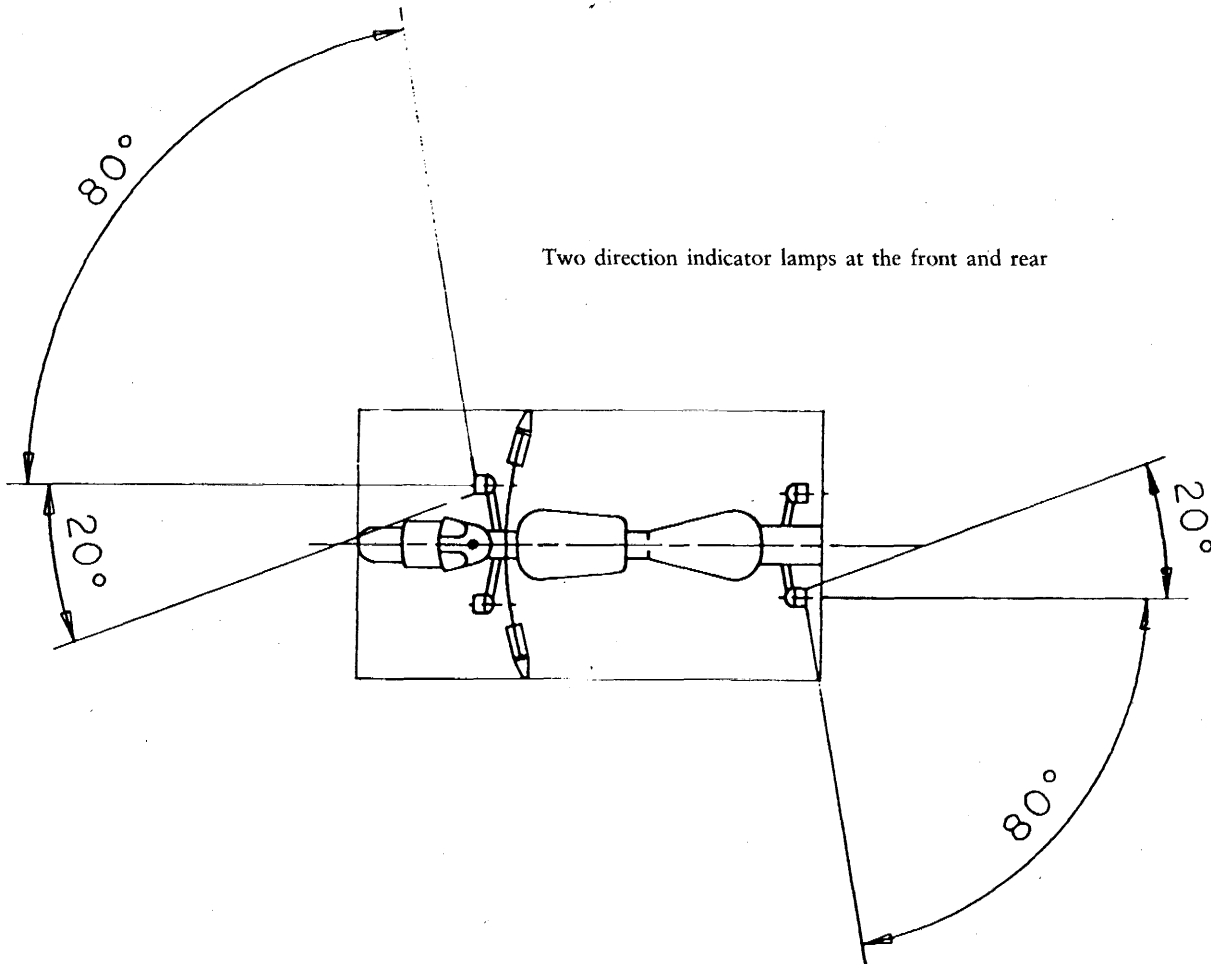

Appendix 3

Information document in respect of the installation of lighting and light-signalling devices on a type of two-wheel moped

(To be attached to the component type-approval application where this is submitted separately from the vehicle type-approval application)

Reference number (allocated by the applicant):

The application for component type approval in respect of the installation of the lighting and light-signalling devices on a type of two-wheel moped shall contain the information set out in Annex II to Directive 92/61/EEC under A, points:

- 0.1,
- 0.2,
- 0.4 to 0.6,
- 8 to 8.4.

Appendix 4

Name of administration

Component type-approval certificate in respect of the installation of lighting and light-signalling devices on a type of two-wheel moped

MODEL

Report No by technical service on (date)

Component type-approval No Extension No

1. Make (trade name) of vehicle
2. Vehicle type
3. Manufacturer's name and address
4. Name and address of manufacturer's representative (if any)
5. Mandatory lighting devices installed on the vehicle submitted for checks (1):
- 5.1. Dipped-beam headlamps
- 5.2. Rear position lamps
- 5.3. Non-triangular side retro-reflectors
- 5.4. Non-triangular rear retro-reflectors
- 5.5. Pedal retro reflectors (2)
- 5.6. Stop lamp(s) (3)
6. Optional lighting devices present on the vehicle submitted for checks (1):
- 6.1. Main-beam headlamps: yes/no (*)
- 6.2. Direction indicator lamp: yes/no (*)
- 6.3. Rear registration plate lamp: yes/no (*)
- 6.4. Front position lamps: yes/no (*)
- 6.5. non-triangular front retro reflector: yes/no (*)
7. Variants
8. Vehicle submitted for component type-approval on (date)
9. Component type-approval has been granted/refused (*)
10. Place
11. Date
12. Signature

(1) State on a separate sheet for each device the duly identified types of devices meeting the fitting requirements of this Annex.
 (2) Only for two-wheel mopeds fitted with pedals.
 (3) Excluding mopeds covered by an exemption such as provided for under section B 14 of Annex I.
 (*) Delete as appropriate.

ANNEX III

REQUIREMENTS CONCERNING THREE-WHEEL MOPEDS AND LIGHT QUADRICYCLES

1. All three-wheel mopeds must be fitted with the following lighting and light-signalling devices:
 - 1.1. dipped-beam headlamp;
 - 1.2. front position lamp;
 - 1.3. rear position lamp;
 - 1.4. non-triangular rear retro-reflectors;
 - 1.5. pedal retro reflectors only where two-wheel mopeds are fitted with pedals;
 - 1.6. stop lamp;
 - 1.7. direction indicator lamps for three-wheel mopeds with closed bodywork.
2. In addition all three-wheel mopeds may be fitted with the following lighting and light-signalling devices:
 - 2.1. main-beam headlamp;
 - 2.2. direction indicator lamps, for three-wheel mopeds without closed bodywork;
 - 2.3. rear registration plate lamp;
 - 2.4. non-triangular side retro-reflectors;
3. Each of the lighting and light-signalling devices referred to in sections 1 and 2 must be fitted in accordance with the appropriate provisions of section 6 below.
4. No lighting and light-signalling device other than those referred to in sections 1 and 2 may be fitted.
5. Lighting and light-signalling devices type-approved for motorcycles and referred to in sections 1 and 2 may also be fitted to mopeds.
6. **SPECIFIC FITTING REQUIREMENTS**
 - 6.1. **Main-beam headlamps**
 - 6.1.1. *Number:* one or two.

However, in the case of three-wheel mopeds with a maximum width exceeding 1 300 mm, two main-beam headlamps are required.
 - 6.1.2. *Arrangement drawing:* no individual specifications.
 - 6.1.3. *Location*
 - 6.1.3.1. *Width:*
 - an independent main-beam headlamp may be fitted above or below or to one side of another front lamp; if these lamps are one above the other the reference centre of the main-beam headlamp must be located within the median longitudinal plane of the vehicle; if these lamps are side by side their reference centres must be symmetrical in relation to the median longitudinal plane of the vehicle,
 - a main-beam headlamp that is reciprocally incorporated with another front lamp must be fitted in such a way that its reference centre lies within the median longitudinal plane of the vehicle; however, when the vehicle is also fitted with an independent dipped-beam headlamp alongside the main-beam headlamp their reference centres must be symmetrical in relation to the median longitudinal plan of the vehicle,
 - two main-beam headlamps of which either one or both are reciprocally incorporated with another front lamp must be fitted in such a way that their reference centres are symmetrical in relation of the median longitudinal plane of the vehicle.

- 6.1.3.2. The length: at the front of the vehicle. This requirement is considered to have been met if the light emitted does not disturb the driver either directly or indirectly by means of the rear-view mirrors and/or other reflective surfaces on the vehicle.
- 6.1.3.3. In the case of a single independent main-beam headlamp, the distance between the edge of the illuminating surface and that of the dipped-beam headlamp must not exceed 200 mm for each pair of lamps.
- 6.1.4. *Geometrical visibility*
- Even in the zones which do not seem to be illuminated in the direction of observation under consideration, the illuminating surface must be visible within a divergent area limited by generatrices touching the entire contour of the illuminating surface and forming an angle of 5° at least with the headlamp reference axis. The contour of the projection of the illuminating surface on to a transverse plane that is tangent to the front part of the main-beam headlamp lens is considered to be the origin of the angles of geometrical visibility.
- 6.1.5. *Alignment: forwards.*
- May move in line with the steering angle.
- 6.1.6. May be grouped together with the dipped-beam headlamp and the front position lamp.
- 6.1.7. May not be combined with any other lamp.
- 6.1.8. May be reciprocally incorporated:
- 6.1.8.1. with the dipped-beam headlamp;
- 6.1.8.2. with the front position lamp.
- 6.1.9. *Electrical connections*
- The main-beam headlamps must light simultaneously. All main-beam headlamps must light when they are switched from dipped-beam to main-beam. All main-beam headlamps must be extinguished simultaneously when switched from main-beam to dipped-beam. The dipped-beam headlamps may remain lit at the same time as the main-beam headlamps.
- 6.1.10. *Circuit-closed telltale: optional.*
- Blue non-flashing warning light.
- 6.2. **Dipped-beam headlamps**
- 6.2.1. *Number: one or two.*
- However, in the case of three-wheel mopeds, the maximum width of which exceeds 1 300 mm, two main-beam headlamps are required.
- 6.2.2. *Arrangement drawing: no particular specification.*
- 6.2.3. *Position*
- 6.2.3.1. *Width:*
- an independent dipped-beam headlamp may be installed above, below or to one side of another front lamp: if these lamps are one above the other the reference centre of the dipped-beam headlamp must be located in the median longitudinal plane of the vehicle; if these lamps are side by side their reference centres must be symmetrical in relation to the median longitudinal plane of the vehicle,
 - a dipped-beam headlamp that is reciprocally incorporated with another front lamp must be installed in such a way that its reference centre lies within the median longitudinal plane of the vehicle. However, where the vehicle is also fitted with an independent main-beam headlamp alongside the dipped-beam headlamp their reference centres must be symmetrical in relation to the median longitudinal plane of the vehicle,
 - two dipped-beam headlamps, of which either one or both are reciprocally incorporated with another front lamp must be installed in such a way that their reference centres are symmetrical in relation to the median longitudinal plane of the vehicle.
- In the case of a vehicle with two main-beam headlamps:
- the edges of the illuminating surfaces furthest from the median longitudinal plane of the vehicle must not be more than 400 mm from the outermost edge of the vehicle,

- the internal edges of the illuminating surfaces must be at least 500 mm apart. This distance may be reduced to 400 mm if the maximum width of the vehicle is less than 1 300 mm.
- 6.2.3.2. Height: a minimum of 500 mm and a maximum of 1 200 mm above the ground.
- 6.2.3.3. Length: at the front of the vehicle this requirement is considered to have been met if the light emitted does not disturb the driver either directly or indirectly by means of the rear-view mirrors and/or other reflective surfaces of the vehicle.
- 6.2.4. *Geometric visibility*

Determined by angles α and β as specified in section A 10 of Annex I:

α = 15° upwards and 10° downwards;

β = 45° to the left and to the right if there is only one dipped-beam headlamp;
45° outwards and 10° inwards if there are two dipped-beam headlamps.
- 6.2.5. *Alignment forwards.*

May move in line with the steering angle.
- 6.2.6. May be grouped together with the main-headlamp and the front position lamp.
- 6.2.7. May not be combined with any other lamp.
- 6.2.8. May be reciprocally incorporated with the main headlamp and the front position lamp.
- 6.2.9. *Electrical connections*

The control for changing to the dipped beam must switch off all main-beam headlamps simultaneously, whereas the dipped beams may remain switched on at the same time as the main beam.
- 6.2.10. *Circuit-closed telltale:* optional.

Green non-flashing indicator light.
- 6.2.11. *Other requirements:* none.
- 6.3. **Direction indicator lamps**
- 6.3.1. *Number:* two per side.
- 6.3.2. *Arrangement drawing:* two front and two rear indicator lamps.
- 6.3.3. *Position*
- 6.3.3.1. *Width:*
 - the edges of the illuminating surface furthest from the median longitudinal plane must also not be more than 400 mm from the outermost part of the vehicle,
 - the internal edges of the illuminating surfaces must be at a distance of at least 500 mm,
 - there must be a minimum distance between the illuminating surfaces of the nearest indicators and dipped-beam headlamps of:
 - 75 mm in the case of a minimum indicator intensity of 90 cd,
 - 40 mm in the case of a minimum indicator intensity of 175 cd,
 - 20 mm in the case of a minimum indicator intensity of 250 cd,
 - \leq 20 mm in the case of a minimum indicator intensity of 400 cd.
- 6.3.3.2. Height: minimum 350 mm, maximum 1 500 mm above the ground.
- 6.3.4. *Geometric visibility*

Horizontal angles: see Appendix 2.

Vertical angles: 15° above the horizontal.

However, the vertical angle below the horizontal may be reduced to 5° if the lamps are less than 750 mm above the ground.

- 6.3.5. *Alignment*
- The direction indicator lamps may move in line with the steering angle.
- 6.3.6. May be grouped with one or more lamps.
- 6.3.7. May not be combined with any other lamp.
- 6.3.8. May not be reciprocally incorporated with another lamp.
- 6.3.9. *Electrical connections*
- Direction indicator lamps must switch on independently of the other lamps. All direction indicator lamps on one side of a vehicle must be switched on and off by means of one control.
- 6.3.10. *Operational telltale: optional.*
- This may be optical or auditory or both. If it is optical it must be green and of the flashing type. It must be visible under all normal operating conditions. It must be extinguished or remain alight without flashing or show a marked change of frequency in the event of the malfunction of any of the direction indicator lamps. If it is entirely auditory it must be clearly audible and show the same operating conditions as the optical telltale.
- 6.3.11. *Other requirements*
- The characteristics listed below must be measured with the electrical generator supplying current only to those circuits that are essential to the operation of the engine and lighting devices.
- 6.3.11.1. Actuation of the light-signalling device control must be followed by illumination of the lamp within a maximum of one second and extinction of the first lamp within a maximum of one-and-a-half seconds.
- 6.3.11.2. In the case of all vehicles the direction indicator lamps of which are supplied with direct current:
- 6.3.11.2.1. the flashing-light frequency must be 90 ± 30 times per minute;
- 6.3.11.2.2. the direction indicator lamps on the same side of the vehicle must flash at the same frequency and in phase.
- 6.3.11.3. Where a vehicle is fitted with direction indicator lamps which are supplied with alternating current, when the engine speed lies between 50 and 100 % of the speed corresponding to the maximum speed of the vehicle:
- 6.3.11.3.1. the lights must flash at a frequency of 90 ± 30 times per minute;
- 6.3.11.3.2. the direction indicator lamps may flash on the same side of the vehicle either simultaneously or alternately. The front lamps must not be visible to the rear nor the rear lamps to the front within the zones defined in Appendix 1.
- 6.3.11.4. Where the direction indicator lamps fitted to a vehicle are supplied with alternating current, when the engine speed lies between the idling speed specified by the manufacturer and 50 % of the speed corresponding to the maximum speed of the vehicle:
- 6.3.11.4.1. the flashing frequency must be between $90 + 30$ and $90 - 45$ times per minute;
- 6.3.11.4.2. direction indicator lamps on the same side of the vehicle may flash either simultaneously or alternately. The front lamps must not be visible to the rear, nor the rear lamps visible to the front within the zones defined in Appendix 1.
- 6.3.11.5. In the event of failure, other than a short circuit, of one direction indicator lamp, the other must continue to flash, or remain lit, but the frequency in this state may be different from that specified.
- 6.4. *Stop lamps*
- 6.4.1. *Number:* one or two. However, for three-wheel mopeds with a maximum width exceeding 1 300 mm, two stop lamps are required.
- 6.4.2. *Arrangement drawing:* no individual specifications.
- 6.4.3. *Position*

- 6.4.3.1. Width: if there is only one stop lamp its centre of reference must lie within the median longitudinal plane of the vehicle, or if there are two stop lamps they must be symmetrical to the median longitudinal plane of the vehicle. In the case of vehicles with two rear wheels: at least 600 mm between the two lamps. The distance may be reduced to 400 mm of the maximum width if the vehicle is less than 1 300 mm.
- 6.4.3.2. Height: minimum 250 mm, maximum 1 500 mm above ground.
- 6.4.3.3. Length: at the rear of the vehicle.
- 6.4.4. *Geometric visibility:*
- Horizontal angle: 45° to the left and to the right.
- Vertical angle: 15° above and below the horizontal.
- However, the vertical angle below the horizontal may be reduced to 5° if the lamp is less than 750 mm above the ground.
- 6.4.5. *Alignment:* towards the rear of the vehicle.
- 6.4.6. May be grouped with one or more other rear lamps.
- 6.4.7. May not be combined with any other lamp.
- 6.4.8. May be reciprocally incorporated with the rear position lamp.
- 6.4.9. *Electrical connection:* must light up whenever at least one of the service brakes is applied.
- 6.4.10. *Circuit-closed telltale:* prohibited.
- 6.5. **Front position lamps**
- 6.5.1. *Number:* one or two.
- However, in the case of three-wheel mopeds with a maximum width exceeding 1 300 mm, two front position lamps are required.
- 6.5.2. *Arrangement drawing:* no individual specifications.
- 6.5.3. *Position*
- 6.5.3.1. Width:
- one independent front position lamp may be fitted above or below or to one side of another front lamp: if these lamps are one above the other the reference centre of the front position lamp must be located within the median longitudinal plane of the vehicle; if these lamps are side by side their reference centres must be symmetrical in relation to the median longitudinal plane of the vehicle,
 - a front position lamp that is reciprocally incorporated with another front lamp must be installed in such a way that its reference centre is situated in the median longitudinal plane of the vehicle,
 - two front position lamps one or both of them reciprocally incorporated with another front lamp must be installed in such a way that their geometric centres are symmetrical in relation to the median longitudinal plane of the vehicle.
- In the case of a vehicle with two front position lamps:
- the edges of the illuminating surface furthest from the median longitudinal plane of the vehicle must not be more than 400 mm from the outermost part of the vehicle,
 - the internal edges of the illuminating surfaces must be at a distance of at least 500 mm.
- 6.5.3.2. Height: minimum 350 mm, maximum 1 200 mm above the ground.
- 6.5.3.3. Length: at front of vehicle.
- 6.5.4. *Geometric visibility*
- Horizontal angle: 80° to the left and to the right if there is a single position lamp; 80° to the outside and 45° to the inside if there are two position lamps.
- Vertical angle: 15° above and below the horizontal. However, the vertical angle below the horizontal may be reduced to 5° if the lamp is less than 750 mm above the ground.

- 6.5.5. *Alignment:* towards the front.
May move in line with the steering angle.
- 6.5.6. May be grouped with any other front lamp.
- 6.5.7. May be reciprocally incorporated with any other front lamp.
- 6.5.8. *Electrical connections:* no particular specification.
- 6.5.9. *Circuit-closed telltale:* optional.
Non-flashing green indicator light.
- 6.5.10. Other requirements: none.
- 6.6. **Rear position lamps**
- 6.6.1. *Number:* one or two.
However, for three-wheel mopeds with a maximum width exceeding 1 300 mm, two rear position lamps are required.
- 6.6.2. *Arrangement drawing:* no individual specifications.
- 6.6.3. *Position*
- 6.6.3.1. *Width:* the reference centre must be located within the median longitudinal plane of the vehicle if there is only one position lamp; if there are two position lamps these must be symmetrical to the median longitudinal plane of the vehicle. In the case of vehicles with two rear wheels: at least 600 mm between the two lamps. This distance may be reduced to 400 mm if the maximum width of the vehicle is less than 1 300 mm.
- 6.6.3.2. *Height:* minimum 250 mm, maximum 1 500 mm above the ground.
- 6.6.3.3. *Length:* at rear of vehicle.
- 6.6.4. *Geometric visibility*
Horizontal angle: 80° to the left and to the right if there is a single position lamp; 80° towards the outside and 45° towards the inside if there are two position lamps.
Vertical angle: 15° above and below the horizontal. However, the vertical angle below the horizontal may be reduced to 5° if the lamp is less than 750 mm above the ground.
- 6.6.5. *Alignment:* towards the rear.
- 6.6.6. May be grouped with any other rear lamp.
- 6.6.7. May be reciprocally incorporated with the stop lamp or non-triangular rear retro-reflector, or with both.
- 6.6.8. *Electrical connections:* no particular specification.
- 6.6.9. *Circuit-closed telltale:* optional.
Its function may be fulfilled by the device provided, where appropriate, for the front position lamp.
- 6.6.10. Other requirements: none.
- 6.7. **Non-triangular rear retro-reflectors**
- 6.7.1. *Number:* one or two class IA ⁽¹⁾.
However, in the case of three-wheel mopeds with a maximum width exceeding 1 000 mm, two non-triangular rear reflectors are required.
- 6.7.2. *Arrangement drawing:* no individual specifications.

(¹) In accordance with the classification set out in Directive 76/757/EEC.

6.7.3. *Position*

6.7.3.1. Width: the reference centre must be located within the median longitudinal plane of the vehicle if there is only one retro-reflector or, if there are two retro-reflectors, they must be symmetrical to the median longitudinal plane of the vehicle.

In the case of a vehicle with two rear retro-reflectors:

- the point of the illuminating surface furthest from the median longitudinal plane of the vehicle must not be more than 400 mm from the outermost part of the vehicle,
- the internal edges of the retro-reflectors must be at least 500 mm apart. This distance may be reduced to 400 mm if the maximum width of the vehicle is less than 1 300 mm.

6.7.3.2. Height: minimum 250 mm, maximum 900 mm above the ground.

6.7.3.3. Length: at rear of vehicle.

6.7.4. *Geometric visibility*

Horizontal angles: 30° to the left and right.

Vertical angle: 15° above and below the horizontal.

However, the vertical angle below the horizontal may be reduced to 5° if the reflector is less than 750 mm above the ground.

6.7.5. *Alignment*: towards the rear.

6.7.6. May be grouped with any other lamp.

6.7.7. *Other requirements*: the illuminating surface of the retro-reflector may have parts in common with any other rear-mounted red lamp.

6.8. *Pedal retro-reflectors*

Each pedal of a three-wheel moped must be fitted with two retro-reflectors. They must be fitted in such a way that the operational surfaces are external to the pedal itself, and perpendicular to the bearing plane of the pedal, with their optical axis parallel to the median longitudinal plane of the vehicle.

6.8.1. *Number*: four retro-reflectors or groups of retro-reflectors.

6.8.2. *Arrangement drawing*: no individual specifications.

6.8.3. *Other requirements*

The illuminating surface of the retro reflector must be recessed within its frame. The reflectors must be installed within the body of the pedal in such a way that they are clearly visible both to the front and to the rear of the vehicle. The reference axis of the reflectors the shape of which must be adapted to that of the body of the pedal, must be put at right angles to the axis of the pedal. The pedal reflectors must be mounted only on vehicle pedals which, by means of cranks or similar devices, may act as a means of propulsion instead of the engine. They must not be mounted on pedals acting as vehicle controls or solely as footrests for the driver or passenger.

6.9. *Non-triangular side retro-reflectors*

6.9.1. *Number per side*: one or two of class IA (1).

6.9.2. *Arrangements drawing*: no individual specifications.

6.9.3. *Position*

6.9.3.1. Width: no individual specifications.

6.9.3.2. Height: minimum 300 mm, maximum 900 mm above the ground.

(1) In accordance with the classification set out in Directive 76/757/EEC.

- 6.9.3.3. Length: must be such that, under normal conditions, the device cannot be hidden by the driver or passenger, or by their clothing.
- 6.9.4. *Geometric visibility*
Horizontal angles: 30° towards the front and back.
Vertical angles: 15° above and below the horizontal.
However, the vertical angle below the horizontal may be reduced to 5° if the reflector is less than 750 mm above the ground.
- 6.9.5. *Position*: the reference axis of the retro reflectors must be perpendicular to the median longitudinal plane of the vehicle and positioned outwards. Retro-reflectors at the front move in line with the steering angle.
- 6.9.6. May be grouped with other signalling devices.
- 6.10. **Rear registration plate lamp**
- 6.10.1. *Number*: one.
The lamp may consist of several optical elements intended to illuminate the position of the plate.
- 6.10.2. *Arrangement drawing*
- 6.10.3. *Position*
- 6.10.3.1. Width
- 6.10.3.2. Height
- 6.10.3.3. Length
- 6.10.4. *Geometric visibility*
- 6.10.5. *Position*
- 6.10.6. May be grouped with one or more rear lamps.
- 6.10.7. May be combined with the rear position lamp.
- 6.10.8. May not be reciprocally incorporated with any other lamp.
- 6.10.9. *Operational electrical connections*: no individual specifications.
- 6.10.10. *Circuit-closed telltale*: optional.
Its operation must be ensured by the same telltale as provided for the position lamp.
- 6.10.11. *Other requirements*: none.
- } Such that the lamp illuminates the position reserved for the registration plate.

Appendix 1

Visibility of red lights towards the front and white lights towards the rear

(See point B.9 in Annex I and point 6.3.11.4.2 in this Annex)

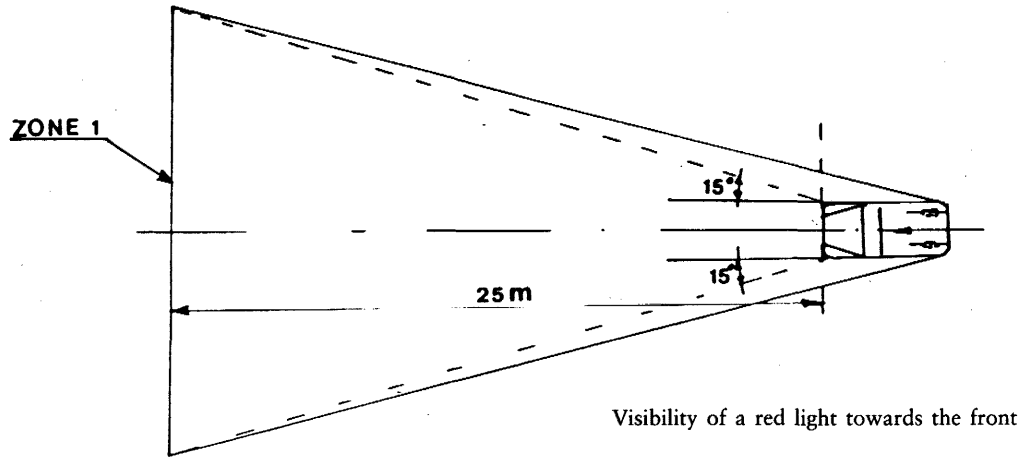

Figure 1

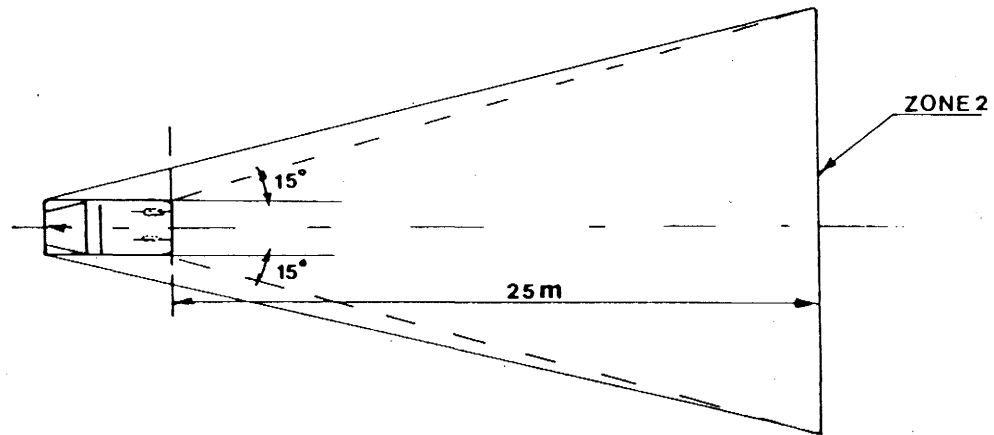
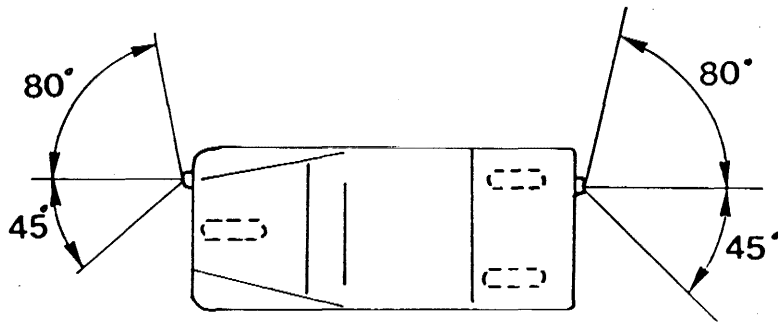

Figure 2

Appendix 2

Arrangement drawing

Direction indicator lamp — Geometric visibility



Appendix 3

Information document in respect of the installation of lighting and light-signalling devices on a type of three-wheel moped

(To be attached to the component type-approval application where this is submitted separately from the vehicle type approval application)

Reference number (allocated by the applicant):

The application for component type approval in respect of the installation of the lighting and light-signalling devices on a type of three-wheel moped shall contain the information set out in Annex II to Council Regulation (EEC) No 92/61/EEC under A, points:

- 0.1,
- 0.2,
- 0.4 to 0.6,
- 8 to 8.4.

Appendix 4

Name of administration

Component type-approval certificate in respect of the installation of lighting and light-signalling devices on a type of three-wheel moped

MODEL

Report No by technical service on (date)

Component type-approval Extension No

1. Make (trade name) of vehicle
2. Vehicle type
3. Manufacturer's name and address
4. Name and address of manufacturer's representative (if any)
5. Mandatory lighting devices installed on the vehicle submitted for checks ⁽¹⁾:
- 5.1. Dipped-beam headlamps
- 5.2. Front position lamps
- 5.3. Rear position lamps
- 5.4. Non-triangular rear retro-reflectors
- 5.5. Pedal retro-reflectors ⁽²⁾
- 5.6. Direction indicator lamps for three-wheel mopeds with closed bodywork
- 5.7. Stop lamp
6. Optional lighting devices installed on the vehicle submitted for checks ⁽¹⁾:
- 6.1. Main-beam headlamps: yes/no (*)
- 6.2. Direction indicator lamps: for three-wheel mopeds without closed bodywork: yes/no (*)
- 6.3. Non-triangular side retro reflectors: yes/no (*)
- 6.4. Rear registration plate lamp: yes/no (*)
7. Variants
8. Vehicle submitted for component type-approval on (date)
9. Component type-approval is granted/refused (*)
10. Place
11. Date
12. Signature

⁽¹⁾ State on a separate sheet for each device the duly identified types of device meeting the fitting requirements of this Annex.

⁽²⁾ Only in the case of three-wheel mopeds fitted with pedals.

(*) Delete as appropriate.

ANNEX IV

REQUIREMENTS CONCERNING TWO-WHEEL MOTORCYCLES

1. All two-wheel motorcycles must be fitted with the following lighting and light-signalling devices:
 - 1.1. main-beam headlamp;
 - 1.2. dipped-beam lamp;
 - 1.3. direction indicator lamps;
 - 1.4. stop lamp;
 - 1.5. front position lamp;
 - 1.6. rear position lamp;
 - 1.7. rear registration plate lamp;
 - 1.8. non-triangular rear retro-reflector.
2. In addition all two-wheel motorcycles may be fitted with the following lighting and light-signalling devices:
 - 2.1. front fog lamp;
 - 2.2. rear fog lamp;
 - 2.3. hazard warning signal;
 - 2.4. non-triangular side retro-reflectors.
3. Each of the lighting and light-signalling devices referred to in sections 1 and 2 must be fitted in line with the appropriate provisions of section 6 below.
4. No lighting and light-signalling device other than those referred to in sections 1 and 2 may be fitted.
5. Lighting and light-signalling devices type-approved for four-wheel motor vehicles of categories M1 and N1 and referred to in sections 1 and 2 may also be fitted to motorcycles.
6. SPECIFIC FITTING REQUIREMENTS
 - 6.1. Main-beam headlamps
 - 6.1.1. *Number*: one or two.
 - 6.1.2. *Arrangement drawing*: no individual specifications.
 - 6.1.3. *Location*
 - 6.1.3.1. *Width*:
 - an independent main-beam headlamp may be fitted above, below or to one side of another front lamp: if these lamps are one above the other the reference centre of the main-beam headlamp must be located within the median longitudinal plane of the vehicle; if these lamps are side by side their reference centre must be symmetrical in relation to the median longitudinal plane of the vehicle,
 - a main-beam headlamp that is reciprocally incorporated with another front lamp must be fitted in such a way that its reference centre lies within the median longitudinal plane of the vehicle. However, when the vehicle is also fitted with an independent dipped-beam headlamp alongside the main-beam headlamp, their reference centres must be symmetrical in relation to the median longitudinal plan of the vehicle,
 - two main-beam headlamps of which either one or both are reciprocally incorporated with another front lamp must be fitted in such a way that their reference centres are symmetrical in relation of the median longitudinal plane of the vehicle.

- 6.1.3.2 The length: at the front of the vehicle. This requirement is considered to have been met if the light emitted does not disturb the driver either directly or indirectly by means of the rear-view mirrors and/or other reflective surfaces on the vehicle.
- 6.1.3.3 In any case, the distance between the edge of the illuminating surface of any independent main-beam headlamp and the edge of that of the dipped-beam headlamp must not exceed 200 mm.
- 6.1.3.4 In the case of two main-beam headlamps: the distance separating the illuminating surfaces of two main-beam headlamps must not exceed 200 mm.
- 6.1.4. *Geometric visibility*
- Even in the zones which do not seem to be illuminated in the direction of observation under consideration, the illuminating surface must be visible within a divergent area limited by generatrices touching the entire contour of the illuminating surface and forming an angle of 5° at least with the headlamp reference axis. The contour of the projection of the illuminating surface on to a transverse plane that is tangent to the front part of the main-beam headlamp lens is considered to be the origin of the angles of geometrical visibility.
- 6.1.5. *Alignment: forwards.*
- May move in line with the steering angle.
- 6.1.6. May be grouped together with the dipped-beam headlamp and the other front lamps.
- 6.1.7. May not be combined with any other lamp.
- 6.1.8. May be reciprocally incorporated:
- 6.1.8.1. with the dipped-beam headlamp;
- 6.1.8.2. with the front position lamp;
- 6.1.8.3. with the front fog lamp.
- 6.1.9. *Electrical connections*
- The main-beam headlamps must light simultaneously. All main-beam headlamps must light when they are switched from dipped-beam to main-beam. All main-beam headlamps must be extinguished simultaneously when switched from main-beam to dipped-beam. The dipped-beam headlamps may remain lit at the same time as the main-beam headlamps.
- 6.1.10. *Circuit-closed telltale: optional.*
- Blue non-flashing warning light.
- 6.1.11. Other requirements: the maximum intensity of the main-beam headlamps which may be lit at the same time must not exceed 225 000 cd (component type-approval value).
- 6.2. **Dipped-beam headlamps**
- 6.2.1. *Number: one or two.*
- 6.2.2. *Arrangement drawing: no particular specifications.*
- 6.2.3. *Position*
- 6.2.3.1. *Width:*
- an independent dipped-beam headlamp may be installed above, below or to one side of another front lamp: if these lamps are one above the other the reference centre of the dipped-beam headlamp must be located in the median longitudinal plane of the vehicle; if these lamps are side by side their reference centres must be symmetrical in relation to the median longitudinal plane of the vehicle,
 - a dipped-beam headlamp that is reciprocally incorporated with another front lamp must be installed in such a way that its reference centre lies within the median longitudinal plane of the vehicle. However, where the vehicle is also fitted with an independent main-beam headlamp alongside the dipped-beam headlamp, their reference centres must be symmetrical in relation to the median longitudinal plane of the vehicle,

- two dipped-beam headlamps, of which either one or both are reciprocally incorporated with another front lamp must be installed in such a way that their reference centres are symmetrical in relation to the median longitudinal plane of the vehicle.
- 6.2.3.2. Height: a minimum of 500 mm and a maximum of 1 200 mm above the ground.
- 6.2.3.3. Length: at the front of the vehicle. This requirement is considered to have been met if the light emitted does not disturb the driver either directly or indirectly by means of the rear-view mirrors and/or other reflective surfaces of the vehicle.
- 6.2.3.4. In the case of two dipped-beam headlamps the distance separating the illuminating surfaces must not exceed 200 mm.
- 6.2.4. *Geometric visibility*

Determined by angles α and β as specified in section A 10 of Annex I:
 $\alpha = 15^\circ$ upwards and 10° downwards;
 $\beta = 45^\circ$ to the left and to the right if there is only one dipped-beam headlamp;
 45° outwards and 10° inwards if there are two dipped-beam headlamps.

The presence of panels or other items of equipment near the light must not give rise to secondary effects causing discomfort to other road users.
- 6.2.5. *Alignment: forwards.*

May move in line with the steering angle.

The vertical inclination of the dipped beam must remain between $-0,5$ and $-2,5$ %, except in the case where an external adjusting device is present.
- 6.2.6. May be grouped together with the main-headlamp and the other front lamps.
- 6.2.7. May not be combined with any other lamp.
- 6.2.8. May be reciprocally incorporated with the main-beam headlamp and the other front lamps.
- 6.2.9. *Electrical connections*

The control for changing to the dipped beam must switch off all main-beam headlamps simultaneously, whereas the dipped beam may remain switched on at the same time as the main beam.
- 6.2.10. *Circuit-closed telltale: optional.*

Green non-flashing indicator light.
- 6.2.11. *Other requirements: none.*
- 6.3. *Direction indicator lamps*
- 6.3.1. *Number: two per side.*
- 6.3.2. *Arrangement drawing: two front and two rear indicator lamps.*
- 6.3.3. *Position*
- 6.3.3.1. *Width:*
- 6.3.3.1.1. the following apply simultaneously to front indicator lamps:
- 6.3.3.1.1.1. there must be a minimum distance of 240 mm between the illuminating surfaces;
- 6.3.3.1.1.2. they must be situated outside the vertical longitudinal planes that are tangent to the outer edges of the illuminating surfaces of the headlamp(s);
- 6.3.3.1.1.3. a minimum distance between the illuminating surfaces of the nearest indicators and the closest dipped-beam headlamps of:
 - 75 mm in the case of a minimum indicator intensity of 90 cd,
 - 40 mm in the case of a minimum indicator intensity of 175 cd,
 - 20 mm in the case of a minimum indicator intensity of 250 cd,
 - ≤ 20 mm in the case of a minimum indicator intensity of 400 cd.
- 6.3.3.1.2. The distance between the inner edges of the illuminating surfaces of the rear indicator lamps must be at least 180 mm, subject to compliance with the requirements of section A 10 of Annex I, even when the registration plate is fitted.

- 6.3.3.2. Height: minimum 350 mm, maximum 1 200 mm above the ground.
- 6.3.3.3. Length: the distance towards the front between the transverse plane corresponding to the extreme longitudinal rearmost extremity of the vehicle and the centre of reference of the rear indicators must not exceed 300 mm.
- 6.3.4. *Geometric visibility*
- Horizontal angles: see Appendix 2.
- Vertical angles: 15° above and below the horizontal.
- However, the vertical angle below the horizontal may be reduced to 5° if the lamps are less than 750 mm above the ground.
- 6.3.5. *Alignment*
- The direction indicator lamps may move in line with the steering angle.
- 6.3.6. May be grouped with one or more lamps.
- 6.3.7. May not be combined with any other lamp.
- 6.3.8. May not be reciprocally incorporated with any other lamp.
- 6.3.9. *Electrical connections:*
- Direction indicator lamps must switch on independently of the other lamps. All direction indicator lamps on one side of a vehicle must be switched on and off by means of one control.
- 6.3.10. *Operational telltale:* optional.
- This may be optical or auditory or both. If it is optical it must be a green flashing light visible under all normal operating conditions. It must be extinguished or remain alight without flashing or show a marked change of frequency in the event of the malfunction of any of the direction indicator lamps. If it is entirely auditory it must be clearly audible and show the same operating conditions as the optical telltale.
- 6.3.11. *Other requirements*
- The characteristics listed below must be measured with the electrical generator supplying current only to those circuits that are essential to the operation of the engine and lighting devices.
- 6.3.11.1. Actuation of the light-signalling device control must be followed by illumination of the lamp within a maximum of one second and initial extinction of the lamp within a maximum of one and a half seconds.
- 6.3.11.2. In the case of all vehicles the direction indicator lamps of which are supplied with direct current:
- 6.3.11.2.1. the flashing-light frequency must be 90 ± 30 times per minute;
- 6.3.11.2.2. the direction indicator lamps on the same side of the vehicle must flash at the same frequency and in phase.
- 6.3.11.3. Where a vehicle is fitted with direction indicator lamps which are supplied with alternating current, when the engine speed lies between 50 and 100 % of the speed corresponding to the maximum speed of the vehicle:
- 6.3.11.3.1. the lights must flash at a frequency of 90 ± 30 times per minute;
- 6.3.11.3.2. the direction indicator lamps may flash on the same side of the vehicle either simultaneously or alternately. The front lamps must not be visible to the rear nor the rear lamps to the front within the zones defined in Appendix 1.
- 6.3.11.4. Where the direction indicator lamps fitted to a vehicle are supplied with alternating current, when the engine speed lies between the idling speed specified by the manufacturer and 50 % of the speed corresponding to the maximum speed of the vehicle:
- 6.3.11.4.1. the flashing frequency must lie between $90 + 30$ and $90 - 45$ times per minute;
- 6.3.11.4.2. direction indicator lamps on the same side of the vehicle may flash either simultaneously or alternately. The front lamps must not be visible to the rear, nor the rear lamps visible to the front within the zones defined in Appendix 1.

- 6.3.11.5. In the event of failure, other than a short circuit, of one direction indicator lamp, the other must continue to flash, or remain lit, but the frequency in this state may be different from that specified.
- 6.4. **Stop lamps**
- 6.4.1. *Number:* one or two.
- 6.4.2. *Arrangement drawing:* no individual specifications.
- 6.4.3. *Position*
- 6.4.3.1. Width: if there is only one stop lamp its centre of reference must lie within the median longitudinal plane of the vehicle, or if there are two stop lamps they must be symmetrical to the median longitudinal plane of the vehicle.
- 6.4.3.2. Height: minimum 250 mm, maximum 1 500 mm above ground.
- 6.4.3.3. Length: at the rear of the vehicle.
- 6.4.4. *Geometric visibility:*
- Horizontal angle: 45° to the left and to the right.
- Vertical angle: 15° above and below the horizontal.
- However, the vertical angle below the horizontal may be reduced to 5° if the lamp is less than 750 mm above the ground.
- 6.4.5. *Alignment:* towards the rear of the vehicle.
- 6.4.6. May be grouped with one or more other rear lamps.
- 6.4.7. May not be combined with any other lamp.
- 6.4.8. May be reciprocally incorporated with the rear position lamp.
- 6.4.9. *Electrical connections:* must light up whenever at least one of the service brakes is applied.
- 6.4.10. *Circuit-closed telltale:* prohibited.
- 6.5. **Front position lamps**
- 6.5.1. *Number:* one or two.
- 6.5.2. *Arrangement drawing:* no individual specifications.
- 6.5.3. *Position*
- 6.5.3.1. Width:
- one independent front position lamp may be fitted above or below or to one side of another front lamp: if these lamps are one above the other the reference centre of the main-beam headlamp must be located within the median longitudinal plane of the vehicle; if these lamps are side by side their reference centres must be symmetrical in relation to the median longitudinal plane of the vehicle,
 - a front position lamp that is reciprocally incorporated with another front lamp must be installed in such a way that its reference centre is situated in the median longitudinal plane of the vehicle,
 - two front position lamps, one or both of them reciprocally incorporated with another front lamp must be installed in such a way that their reference centres are symmetrical in relation to the median longitudinal plane of the vehicle.
- 6.5.3.2. Height: minimum 350 mm, maximum 1 200 mm above the ground.
- 6.5.3.3. Length: at front of vehicle.
- 6.5.4. *Geometric visibility*
- Horizontal angle: 80° to the left and to the right if there is a single position lamp; 80° to the outside and 45° to the inside if there are two position lamps.
- Vertical angle: 15° above and below the horizontal. However, the vertical angle below the horizontal may be reduced to 5° if the lamp is less than 750 mm above the ground.

- 6.5.5. *Alignment:* towards the front.
May move in line with the steering angle.
- 6.5.6. May be grouped with any other front lamp.
- 6.5.7. May be reciprocally incorporated with any other front lamp.
- 6.5.8. *Electrical connections:* no individual specifications.
- 6.5.9. *Circuit-closed telltale:* compulsory.
Non-flashing green indicator light; this telltale is not required if the instrument panel lighting can only be switched on or off together with the position lamp.
- 6.5.10. Other requirements: none.
- 6.6. Rear position lamps**
- 6.6.1. *Number:* one or two.
- 6.6.2. *Arrangement drawing:* no individual specifications.
- 6.6.3. *Position*
- 6.6.3.1. Width: the reference centre must be located within the median longitudinal plane of the vehicle if there is only one position lamp or, if there are two position lamps, these must be symmetrical to the median longitudinal plane of the vehicle.
- 6.6.3.2. Height: minimum 250 mm, maximum 1 500 mm above the ground.
- 6.6.3.3. Length: at rear of vehicle.
- 6.6.4. *Geometric visibility*
- Horizontal angle: 80° to the left and to the right if there is a single position lamp; 80° towards the outside and 45° to the inside if there are two-position lamps.
- Vertical angle: 15° above and below the horizontal. However, the vertical angle below the horizontal may be reduced to 5° if the lamp is less than 750 mm above the ground.
- 6.6.5. *Alignment:* towards the rear.
- 6.6.6. May be grouped with any other rear lamp.
- 6.6.7. May be combined with the rear registration plate lamp.
- 6.6.8. May be reciprocally incorporated with the stop lamp or non-triangular rear retro-reflector, or with both, or with the rear fog lamp.
- 6.6.9. *Electrical connections:* no individual specifications.
- 6.6.10. *Circuit-closed telltale:* optional.
Its function may be fulfilled by the device provided, where appropriate, for the front position lamp.
- 6.6.11. Other requirements: none.
- 6.7. Front fog lamps**
- 6.7.1. *Number:* one or two.
- 6.7.2. *Arrangement drawing:* no individual specifications.
- 6.7.3. *Position*
- 6.7.3.1. Width:
- a front fog lamp may be installed above, below or next to another front lamp; if these lamps are on top of each other, the reference centre of the front fog lamp must be located within the median longitudinal plane of the vehicle; if the two lamps are side by side, their reference centres must be symmetrical in relation of the median longitudinal plane of the vehicle,
 - a front fog lamp that is reciprocally incorporated with another front lamp must be installed in such a way that its reference centre is situated in the median longitudinal plane of the vehicle,

- two front fog lamps, one or both of them reciprocally incorporated with another front lamp, must be installed in such a way that their reference centres are symmetrical in relation of the median longitudinal plane of the vehicle.
- 6.7.3.2. Height: 250 mm minimum above the ground. No point of the illuminating surface may be above the highest point of the illuminating surface of the dipped-beam headlamp.
- 6.7.3.3. Length: at the front of the vehicle. This requirement is considered to have been met if the light emitted does not disturb the driver, either directly or indirectly by means of the rear-view mirrors and/or other reflective surfaces of the vehicle.
- 6.7.4. *Geometric visibility*
This is determined by the angles α and β as defined in section A 10 of Annex I:
 $\alpha = 5^\circ$ upwards and downwards;
 $\beta = 45^\circ$ to the left and to the right in the case of a non-central lamp, in which case the internal angle must be $\beta = 10^\circ$.
- 6.7.5. *Alignment: towards the front.*
May move in line with the steering angle.
- 6.7.6. May be grouped with the other front lamps.
- 6.7.7. May not be combined with any other front lamp.
- 6.7.8. May be reciprocally incorporated with a main-beam headlamp and a front position lamp.
- 6.7.9. *Electrical connections*
It must be possible to switch the front fog lamp on or off independently of the main-beam headlamp or the dipped-beam lamp.
- 6.7.10. *Circuit-closed telltale: optional.*
Green non-flashing indicator light.
- 6.7.11. *Other requirements: none.*
- 6.8. **Rear fog lamps**
- 6.8.1. *Number: one or two.*
- 6.8.2. *Arrangement drawing: no individual specifications.*
- 6.8.3. *Position*
- 6.8.3.1. Width: one independent rear fog lamp may be fitted above, below or next to another rear lamp; its reference centre must be situated in the median longitudinal plane of the vehicle if the lamps are on top of each other; if the lamps are next to each other, their reference centres must be symmetrical in the relation to the median longitudinal plane of the vehicle. A rear fog lamp reciprocally incorporated with another rear lamp must be installed in such a way that its reference centre is situated in the median longitudinal plane of the vehicles.
- 6.8.3.2. Height: minimum 250 mm, maximum 900 mm above the ground.
- 6.8.3.3. Length: at the rear of the vehicle.
- 6.8.3.4. The distance between the illuminating surface of the rear fog lamp and that of the stop lamp must be at least 100 mm.
- 6.8.4. *Geometrical visibility*
This is determined by the angles α and β as defined in section A 10 of Annex I:
 $\alpha = 5^\circ$ upwards and 5° downwards;
 $\beta = 25^\circ$ to the left and to the right.
- 6.8.5. *Position: to the rear.*
- 6.8.6. May be grouped with any other rear lamp.
- 6.8.7. May not be combined with any other lamp.
- 6.8.8. May be reciprocally incorporated with a rear position lamp.

- 6.8.9. *Electrical connections*
The lamp may not be alight unless one or more of the following lamps are lit: the main-beam headlamp, the dipped-beam headlamp or the front fog lamp.
If there is a front fog lamp, it must be possible to switch the rear fog lamp off independently of the fog lamp.
- 6.8.10. *Circuit-closed telltale: compulsory.*
Non-flashing amber indicator light.
- 6.8.11. *Other requirements: none.*
- 6.9. **Hazard warning signal**
- 6.9.1. Requirements identical to those set out in sections 6.3. to 6.3.8.
- 6.9.2. *Electrical connections*
The signal must be actuated by a separate control which enables all of the direction indicators to be supplied with current simultaneously.
- 6.9.3. *Circuit-closed telltale: compulsory.*
A red flashing light or, if there is not a separate telltale, the simultaneous operation of the telltales specified in 6.3.10.
- 6.9.4. *Other requirements*
A light flashing at the frequency of 90 ± 30 times per minute. Actuation of the light-signalling device must be followed by illumination of the lamp within a maximum of one second and initial extinction of the lamp within a maximum of one-and-a-half seconds.
It must be possible to actuate the hazard warning signal even if the device for switching the engine on or off is in a position such that it is impossible for the latter to operate.
- 6.10. **Rear registration plate lamp**
- 6.10.1. *Number: one.*
The lamp may consist of several optical elements intended to illuminate the position of the plate.
- 6.10.2. *Arrangement drawing*
- 6.10.3. *Position*
- 6.10.3.1. Width
- 6.10.3.2. Height
- 6.10.3.3. Length
- 6.10.4. *Geometric visibility*
- 6.10.5. Position
- 6.10.6. May be grouped with one or more rear lamps.
- 6.10.7. May be combined with the rear position lamp.
- 6.10.8. May not be reciprocally incorporated with any other lamp.
- 6.10.9. *Operational electrical connections: no individual specifications.*
- 6.10.10. *Circuit-closed telltale: optional.*
Its operation must be ensured by the same telltale as provided for the position lamp.
- 6.10.11. *Other requirements: none.*
- 6.11. **Non-triangular side retro-reflectors**
- 6.11.1. *Number per side: one or two class IA ⁽¹⁾.*

} Such that the lamp illuminates the position reserved for the registration plate.

(¹) In accordance with the classification set out in Directive 76/757/EEC.

- 6.11.2. *Arrangement drawing*: no individual specifications.
- 6.11.3. *Position*
- 6.11.3.1. Width: no individual specifications.
- 6.11.3.2. Height: 300 mm minimum, 900 mm maximum above the ground.
- 6.11.3.3. Length: must be such that, under normal conditions, the device cannot be masked by the driver or the passenger, nor by their clothing.
- 6.11.4. *Geometric visibility*
- Horizontal angles: 30° towards the front and rear.
- Vertical angles: 15° above and below the horizontal.
- However, the vertical angle below the horizontal may be reduced to 5° if the height of the retro reflector is less than 750 mm.
- 6.11.5. *Position*: the reference axis of the retro reflectors must be perpendicular to the median longitudinal plane of the vehicle and positioned outwards. Retro reflectors at the front may move in line with the steering angle.
- 6.11.6. May be grouped with the other signalling devices.
- 6.12. **Non-triangular rear retro-reflectors**
- 6.12.1. *Number*: one, class IA (1).
- 6.12.2. *Arrangement drawing*: no individual specifications.
- 6.12.3. *Location*
- 6.12.3.1. Width: the reference centre must be situated in the median longitudinal plane of the vehicle.
- 6.12.3.2. Height: minimum 250 mm, maximum 900 mm above the ground.
- 6.12.3.3. Length: to the rear of the vehicle.
- 6.12.4. *Geometrical visibility*
- Horizontal angle: 30° to the left and to the right.
- Vertical angle: 15° above and below the horizontal.
- However, the vertical angle below the horizontal may be reduced to 5° if the height of the retro reflector is less than 750 mm.
- 6.12.5. *Location*: to the rear.
- 6.12.6. May be grouped with any other lamp.
- 6.12.7. The illuminating surface of the retro reflector may have parts in common with any other red rear lamp.

(1) In accordance with the classification set out in Directive 76/757/EEC.

Appendix 1

Visibility of red lights towards the front and white lights towards the rear

(See point B.9 in Annex I and point 6.3.11.4.2 in this Annex)

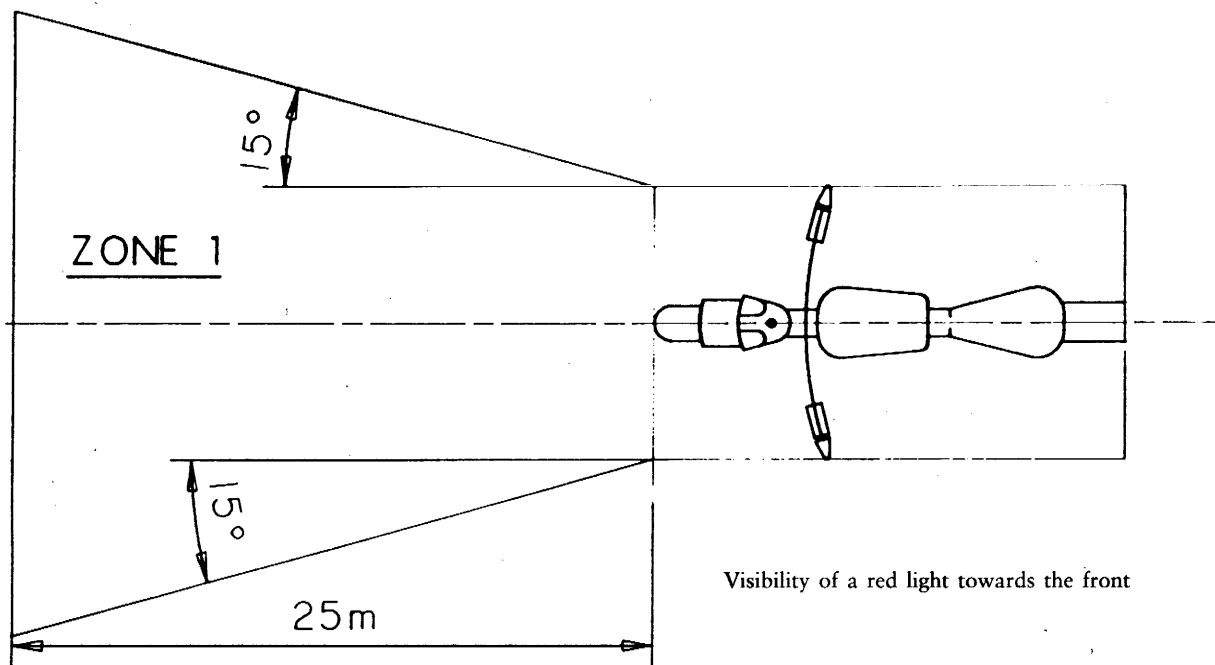

Figure 1

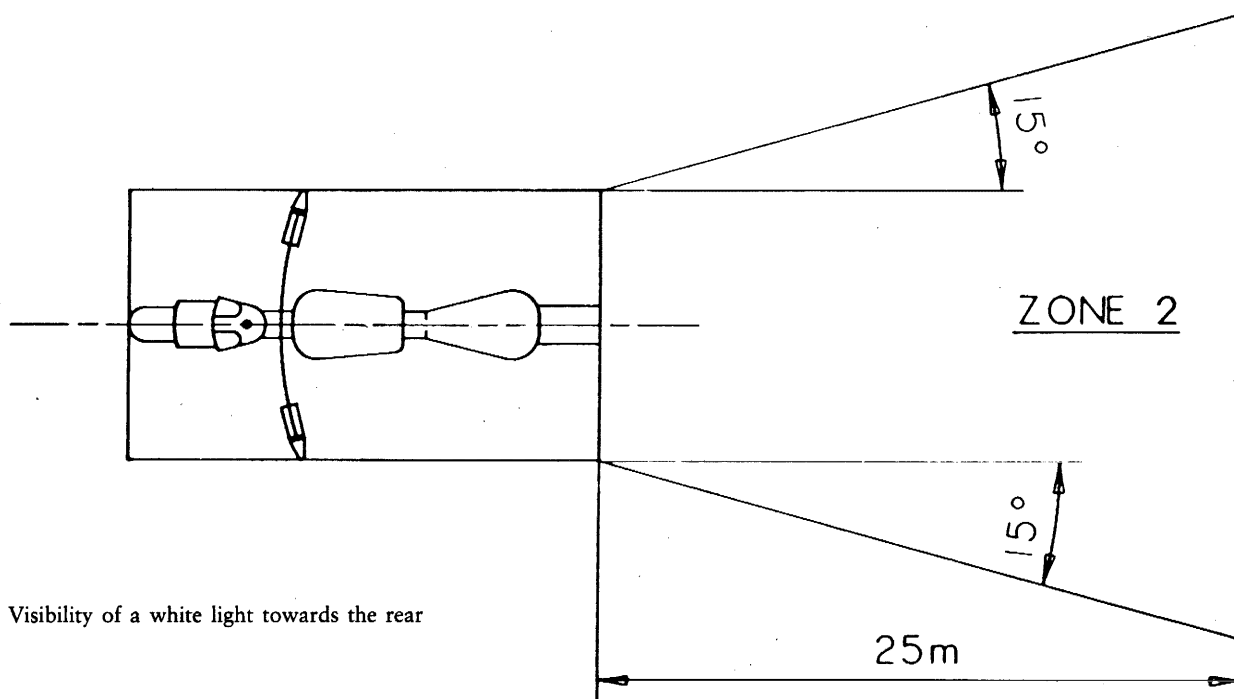
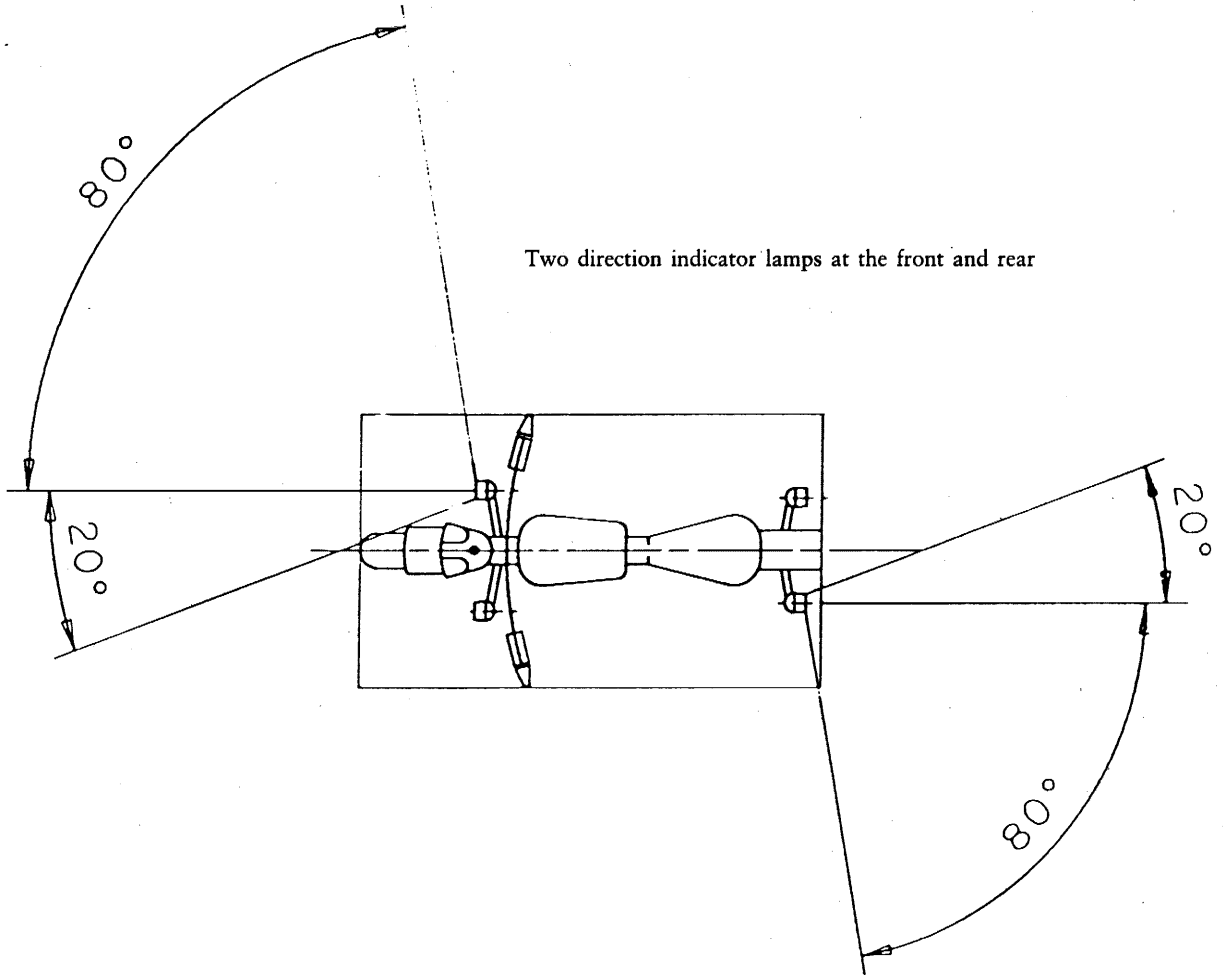

Figure 2

Appendix 2

Arrangement drawing



Appendix 3

Information document in respect of the installation of lighting and light-signalling devices on a type of two-wheel motorcycle

(To be attached to the component type-approval application where this is submitted separately from the vehicle type-approval application)

Reference number (allocated by the applicant):

The application for component type-approval in respect of the installation of the lighting and light-signalling devices on a type of two-wheel motorcycle shall contain the information set out in Annex II to Directive 92/61/EEC under A, points:

- 0.1,
- 0.2,
- 0.4 to 0.6,
- 8 to 8.4.



Appendix 4

Name of administration

Component type-approval certificate in respect of the installation of lighting and light-signalling devices on a type of two-wheel motorcycle

MODEL

- Report No by technical service on (date)
- Component type-approval No Extension No
1. Make (trade name) of vehicle
 2. Vehicle type
 3. Manufacturer's name and address
 4. Name and address of manufacturer's representative (if any)
 5. Mandatory lighting equipment installed on the vehicle submitted for checks ⁽¹⁾:
 - 5.1. Main-beam headlamps
 - 5.2. Dipped-beam headlamps
 - 5.3. Direction indicator lamps
 - 5.4. Stop lamps
 - 5.5. Front position lamps
 - 5.6. Rear position lamps
 - 5.7. Rear registration plate lamp
 - 5.8. Non-triangular rear retro-reflectors
 6. Optional lighting devices fitted to the vehicle submitted for checks ^(*):
 - 6.1. Front fog lamps: yes/no ^(*)
 - 6.2. Rear fog lamps: yes/no ^(*)
 - 6.3. Hazard warning signal: yes/no ^(*)
 - 6.4. Non-triangular side retro reflectors: yes/no ^(*)
 7. Variants
 8. Vehicle submitted for component type-approval on (date)
 9. Component type-approval has been granted/refused ^(*)
 10. Place
 11. Data
 12. Signature

⁽¹⁾ State on a separate sheet for each device the duly identified types of device meeting the fitting requirements of this Annex.
^(*) Delete as appropriate.

ANNEX V

REQUIREMENTS CONCERNING MOTORCYCLES WITH SIDE-CAR

1. All motorcycles with side-car must be fitted with the following lighting and light-signalling devices:
 - 1.1. main-beam headlamp;
 - 1.2. dipped-beam headlamp;
 - 1.3. direction indicator lamps;
 - 1.4. stop lamp;
 - 1.5. front position lamp;
 - 1.6. rear position lamp;
 - 1.7. rear registration plate lamp;
 - 1.8. non-triangular rear retro-reflector.
2. All motorcycles with side-car may also be fitted with the following lighting and light-signalling devices:
 - 2.1. front fog lamp;
 - 2.2. rear fog lamp;
 - 2.3. hazard warning signal;
 - 2.4. non-triangular side retro-reflectors.
3. Each of the lighting and light-signalling devices referred to in sections 1 and 2 must be fitted in accordance with the appropriate provisions of section 6 below.
4. No lighting and light-signalling device other than those referred to in sections 1 and 2 may be fitted.
5. Lighting and light-signalling devices type-approved for four-wheel motor vehicles of categories M₁ and N₁ and referred to in sections 1 and 2 must also be permitted on motorcycles with side-car.
6. **SPECIFIC FITTING REQUIREMENTS**
 - 6.1. **Main-beam headlamps**
 - 6.1.1. *Number:* one or two.
 - 6.1.2. *Arrangement drawing:* no individual specifications.
 - 6.1.3. *Location*
 - 6.1.3.1. *Width:*
 - an independent main-beam headlamp may be fitted above, below or to one side of another front lamp: if these lamps are one above the other the reference centre of the main-beam headlamp must be located within the median longitudinal plane of the motorcycle; if these lamps are side by side their reference centre must be symmetrical in relation to the median longitudinal plane of the motorcycle,
 - a main-beam headlamp that is reciprocally incorporated with another front lamp must be fitted in such a way that its reference centre lies within the median longitudinal plane of the motorcycle. However, when the motorcycle is also fitted with an independent dipped-beam headlamp alongside the main-beam headlamp, their reference centres must be symmetrical in relation to the median longitudinal plan of the motorcycle,
 - two main-beam headlamps of which either one or both are reciprocally incorporated with another front lamp must be fitted in such a way that their reference centres are symmetrical in relation of the median longitudinal plane of the motorcycle.

- 6.1.3.2 The length: at the front of the vehicle. This requirement is considered to have been met if the light emitted does not disturb the driver either directly or indirectly by means of the rear-view mirrors and/or other reflective surfaces on the vehicle.
- 6.1.3.3 In any case, the distance between the edge of the illuminating surface of any independent main-beam headlamp and the edge of that of the dipped-beam headlamp must not exceed 200 mm.
- 6.1.3.4 The distance separating the illuminating of two main-beam headlamps must not exceed 200 mm.
- 6.1.4 *Geometrical visibility*
- Even in the zones which do not seem to be illuminated in the direction of observation under consideration, the illuminating surface must be visible within a divergent area limited by generatrices touching the entire contour of the illuminating surface and forming an angle of 5° at least with the headlamp reference axis. The contour of the projection of the illuminating surface on to a transverse plane that is tangent to the front part of the mainbeam headlamp lens is considered to be the origin of the angles of geometrical visibility.
- 6.1.5 *Alignment: forwards.*
- May move in line with the steering angle.
- 6.1.6 May be grouped together with the dipped-beam headlamp and the other front lamps.
- 6.1.7 May not be combined with any other lamp.
- 6.1.8 May be reciprocally incorporated:
- 6.1.8.1 with the dipped-beam headlamp;
- 6.1.8.2 with the front position lamp;
- 6.1.8.3 with the front fog lamp.
- 6.1.9 *Electrical connections*
- The main-beam headlamps must switch on simultaneously. When switching from the dipped to the main-beam all of the main-beam headlamps must be lit. When switching from the main beam to the dipped-beams all of the main-beam headlamps must be switched off simultaneously. The dipped-beam headlamps may remain lit at the same time as the main-beam headlamps.
- 6.1.10 *Circuit-closed telltale: optional.*
- Blue non-flashing warning light.
- 6.1.11 Other requirements: the maximum intensity of the main-beam headlamps which can be switches on at the same time must not exceed 225 000 cd (component type-approval value).
- 6.2 *Dipped-beam headlamps*
- 6.2.1 *Number: one or two.*
- 6.2.2 *Arrangement drawing: no individual specifications.*
- 6.2.3 *Position*
- 6.2.3.1 *Width:*
- an independent dipped-beam headlamp may be installed above, below or to one side of another front lamp; if these lamps are one above the other the reference centre of the dipped-beam headlamp must be located in the median longitudinal plane of the motorcycle; if these lamps are side by side their reference centres must be symmetrical in relation to the median longitudinal plane of the motorcycle,
 - a dipped-beam headlamp that is reciprocally incorporated with another front lamp must be installed in such a way that its reference centre lies within the median longitudinal plane of the motorcycle. However, where the motorcycle is also fitted with an independent main-beam headlamp alongside the dipped-beam headlamp, their reference centres must be symmetrical in relation to the median longitudinal plane of the motorcycle,

- two dipped-beam headlamps, of which either one or both are reciprocally incorporated with another front lamp, must be installed in such a way that their reference centres are symmetrical in relation to the median longitudinal plane of the motorcycle.
- 6.2.3.2. Height: a minimum of 500 mm and a maximum of 1 200 mm above the ground.
- 6.2.3.3. Length: at the front of the vehicle. This requirement is considered to have been met if the light emitted does not disturb the driver either directly or indirectly by means of the rear-view mirrors and/or other reflective surfaces of the vehicle.
- 6.2.3.4. In the case of two dipped-beam headlamps the distance separating the illuminating surfaces must not exceed 200 mm.
- 6.2.4. *Geometric visibility*
Determined by angles α and β as specified in section A 10 of Annex I:
 $\alpha = 15^\circ$ upwards and 10° downwards;
 $\beta = 45^\circ$ to the left and to the right if there is only one dipped-beam headlamps;
 45° outwards and 10° inwards if there are two dipped-beam headlamps.
The presence of panels or other items of equipment near the light must not give rise to secondary effects causing discomfort to other road users.
- 6.2.5. *Alignment: forwards.*
May move in line with the steering angle.
The vertical inclination of the dipped beam must remain between $-0,5\%$ and $-2,5\%$, except in the case where an external adjusting device is present.
- 6.2.6. May be grouped together with the main-headlamp and the other front lamps.
- 6.2.7. May not be combined with any other lamp.
- 6.2.8. May be reciprocally incorporated with the main headlamp and the other front lamps.
- 6.2.9. *Electrical connections*
The control for changing to the dipped-beam must switch off all main-beam headlamps simultaneously, whereas the dipped-beams may remain switched on at the same time as the main beam.
- 6.2.10. *Circuit-closed telltale: optional.*
Green non-flashing indicator light.
- 6.2.11. *Other requirements: none.*
- 6.3. *Direction indicator lamps*
- 6.3.1. *Number: two per side.*
- 6.3.2. *Arrangement drawing: two front and two rear indicator lamps.*
- 6.3.3. *Position*
- 6.3.3.1. Width:
— the edges of the illuminating surfaces furthest from the median longitudinal plane must not be more than 400 mm from the outermost part of the vehicle,
— the internal edges of the illuminating surfaces must be at least 600 mm apart,
— there must be a minimum distance between the illuminating surfaces of the indicators and the nearest dipped-beam headlamps of:
— 75 mm in the case of a minimum indicator intensity of 90 cd,
— 40 mm in the case of a minimum indicator intensity of 175 cd,
— 20 mm in the case of a minimum indicator intensity of 250 cd,
— ≤ 20 mm in the case of a minimum indicator intensity of 400 cd.
- 6.3.3.2. Length: the distance towards the front between the transverse plane corresponding to the extreme longitudinal rearmost extremity of the vehicle and the centre of reference of the rear indicators must not exceed 300 mm. The front direction indicator on the side-car must be ahead of the centre axis of the side-car and the rear direction indicator must be to the rear of the centre axis of the side-car.

- 6.3.4. *Geometric visibility*
- Horizontal angles: see Appendix 2.
- Vertical angles: 15° above and below the horizontal.
- However, the vertical angle below the horizontal may be reduced to 5° if the lamps are less than 750 mm above the ground.
- 6.3.5. *Alignment*
- The direction indicator lamps may move in line with the steering angle.
- 6.3.6. May be grouped with one or more lamps.
- 6.3.7. May not be combined with any other lamp.
- 6.3.8. May not be reciprocally incorporated with any other lamp.
- 6.3.9. *Electrical connections*
- Direction indicator lamps must switch on independently of the other lamps. All direction indicator lamps on one side of a vehicle must be switched on and off by means of one control.
- 6.3.10. *Operational telltale: optional.*
- This may be optical or auditory or both. If it is optical it must be green flashing light visible under all normal operating conditions. It must be extinguished or remain alight without flashing or show a marked change of frequency in the event of the malfunction of any of the direction indicator lamps. If it is entirely auditory it must be clearly audible and show the same operating conditions as the optical telltale.
- 6.3.11. *Other requirements*
- The characteristics listed below must be measured with the electrical generator supplying current only to those circuits that are essential to the operation of the engine and lighting devices.
- 6.3.11.1. Actuation of the light-signalling device control must be followed by illumination of the lamp within a maximum of one second and initial extinction of the lamp within a maximum of one-and-a-half seconds.
- 6.3.11.2. In the case of all vehicles the direction indicator lamps of which are supplied with direct current:
- 6.3.11.2.1. the flashing-light frequency must be 90 ± 30 times per minute;
- 6.3.11.2.2. the direction indicator lamps on the same side of the vehicle must flash at the same frequency and in phase.
- 6.3.11.3. Where a vehicle is fitted with direction indicator lamps which are supplied with alternating current, when the engine speed lies between 50 and 100 % of the speed corresponding to the maximum speed of the vehicle:
- 6.3.11.3.1. the lights must flash at a frequency of 90 ± 30 times per minute;
- 6.3.11.3.2. the direction indicator lamps may flash on the same side of the vehicle either simultaneously or alternately. The front lamps must not be visible to the rear nor the rear lamps to the front within the zones defined in Appendix 1.
- 6.3.11.4. Where the direction indicator lamps fitted to a vehicle are supplied with alternating current, when the engine speed lies between the idling speed specified by the manufacturer and 50 % of the speed corresponding to the maximum speed of the vehicle:
- 6.3.11.4.1. the flashing frequency must lie between $90 + 30$ and $90 - 45$ times per minute;
- 6.3.11.4.2. direction indicator lamps on the same side of the vehicle may flash either simultaneously or alternately. The front lamps must not be visible to the rear, nor the rear lamps visible to the front within the zones defined in Appendix 1.
- 6.3.11.5. In the event of failure, other than a short circuit, of one direction indicator lamp, the other must continue to flash, or remain lit, but the frequency in this state may be different from that specified.

- 6.4. **Stop lamps**
- 6.4.1. *Number:* one or three (only one of which on the side-car).
- 6.4.2. *Arrangement drawing:* no individual specifications.
- 6.4.3. *Position*
- 6.4.3.1. *Width:* the lateral distance between the outermost edge of the illuminating surfaces of the outermost stop lamps and the overall width must not exceed 400 mm. Where a third stop lamp is fitted it must be symmetrical to the stop lamp that is not fitted to the side-car in relation to the median longitudinal plane of the motorcycle.
- 6.4.3.2. *Height:* minimum 250 mm, maximum 1 500 mm above ground.
- 6.4.3.3. *Length:* at the rear of the vehicle.
- 6.4.4. *Geometric visibility:*
- Horizontal angle: 45° to the left and to the right. Where a stop lamp is fitted to the side-car: 45° to the outside and 10° to the inside.
- Vertical angle: 15° above and below the horizontal.
- However, the vertical angle below the horizontal may be reduced to 5° if the lamp is less than 750 mm above the ground.
- 6.4.5. *Alignment:* towards the rear of the vehicle.
- 6.4.6. May be grouped with one or more other rear lamps.
- 6.4.7. May not be combined with any other lamp.
- 6.4.8. May be reciprocally incorporated with the rear position lamp.
- 6.4.9. *Electrical connection:* must light up whenever at least one of the service brakes is applied.
- 6.4.10. *Circuit-closed telltale:* prohibited.
- 6.5. **Front position lamps**
- 6.5.1. *Number:* two or three (one only on the side-car).
- 6.5.2. *Arrangement drawing:* no individual specifications.
- 6.5.3. *Position*
- 6.5.3.1. *Width:* the lateral distance between the outermost edge of the illuminating surfaces of the outermost two front position lamps and the outermost edges of the vehicle must not exceed 400 mm. Where a third front position lamp is fitted it must be symmetrical to the front position lamp other than that fitted to the side-car, in relation to the median longitudinal plan of the motorcycle.
- 6.5.3.2. *Height:* minimum 350 mm, maximum 1 200 mm above the ground.
- 6.5.3.3. *Length:* at front of vehicle.
- 6.5.4. *Geometric visibility*
- Horizontal angle: 80° to the outside and 45° to the inside.
- Vertical angle: 15° above and below the horizontal. However, the vertical angle below the horizontal may be reduced to 5° if the lamp is less than 750 mm above the ground.
- 6.5.5. *Alignment:* towards the front.
- May move in line with the steering angle.
- 6.5.6. May be grouped with any other front lamp.
- 6.5.7. May be reciprocally incorporated with any other front lamp.
- 6.5.8. *Electrical connections:* no individual specifications.
- 6.5.9. *Circuit-closed telltale:* compulsory.
- Non-flashing green pilot light; this telltale is not required where the dashboard lighting can only be switched on and off simultaneously with the position lamp.

- 6.5.10. Other requirements: none.
- 6.6. Rear position lamps
- 6.6.1. *Number*: two or three (one only on the side-car).
- 6.6.2. *Arrangement drawing*: no individual specifications.
- 6.6.3. *Position*
- 6.6.3.1. *Width*: the lateral distance between the outermost edge of the illuminating surfaces of the outermost rear position lamps and the outermost edges of the vehicle must not exceed 400 mm. Where a third rear position lamp is fitted it must be symmetrical to the front position lamp other than that fitted to the side-car, in relation to the median longitudinal plane of the motorcycle.
- 6.6.3.2. *Height*: minimum 250 mm, maximum 1 500 mm above the ground.
- 6.6.3.3. *Length*: at rear of vehicle.
- 6.6.4. *Geometric visibility*
- Horizontal angle: 80° to the outside and 45° to the inside.
- Vertical angle: 15° above and below the horizontal.
- However, the vertical angle below the horizontal may be reduced to 5° if the lamp is less than 750 mm above the ground.
- 6.6.5. *Alignment*: towards the rear.
- 6.6.6. May be grouped with any other rear lamp.
- 6.6.7. May be combined with the rear registration plate lamp.
- 6.6.8. May be reciprocally incorporated with the stop lamp or non-triangular rear retro-reflector, or with both, or with the rear fog lamp.
- 6.6.9. *Electrical connections*: no individual specifications.
- 6.6.10. *Circuit-closed telltale*: optional.
- Its function may be fulfilled by the device provided, where appropriate, for the front position lamp.
- 6.6.11. *Other requirements*: none.
- 6.7. Front fog lamps
- 6.7.1. *Number*: one or two.
- 6.7.2. *Arrangement drawing*: no individual specifications.
- 6.7.3. *Position*
- 6.7.3.1. *Width*:
- one independent front position lamp may be fitted above or below or to one side of another front lamp: if these lamps are one above the other the reference centre of the main-beam headlamp must be located within the median longitudinal plane of the vehicle; if these lamps are side by side their reference centres must be symmetrical in relation to the median longitudinal plane of the vehicle,
 - a front position lamp that is reciprocally incorporated with another front lamp must be installed in such a way that its reference centre is situated in the median longitudinal plane of the vehicle,
 - two front position lamps, one or both of them, reciprocally incorporated with another front lamp, must be installed in such a way that their reference centres are symmetrical in relation to the median longitudinal plane of the vehicle.
- 6.7.3.2. *Height*: 250 mm minimum above the ground. No point of the illuminating surface must be above the highest point of the illuminating surface of the dipped-beam headlamp.
- 6.7.3.3. *Length*: at the front of the vehicle, this requirement is considered to have been met if the light emitted does not disturb the driver, either directly or indirectly by means of the rear-view mirrors and/or other reflective surfaces of the vehicle.

- 6.7.4. **Geometric visibility**
This is determined by the angles α and β as defined in section A 10 of Annex I:
 $\alpha = 5^\circ$ upwards and downwards;
 $\beta = 45^\circ$ to the outside and 10° towards the inside.
- 6.7.5. *Alignment:* towards the front.
May move in line with the steering angle.
- 6.7.6. May be grouped with the other front lamps.
- 6.7.7. May not be combined with any other front lamp.
- 6.7.8. May be reciprocally incorporated with a main-beam headlamp and a front position lamp.
- 6.7.9. *Electrical connections*
It must be possible to switch the front fog lamp on or off independently of the main-beam headlamp or the dipped-beam lamp.
- 6.7.10. *Circuit-closed telltale:* optional.
Green non-flashing indicator light.
- 6.7.11. *Other requirements:* none.
- 6.8. **Rear fog lamps**
- 6.8.1. *Number:* one or two.
- 6.8.2. *Arrangement drawing:* no individual specifications.
- 6.8.3. *Position*
- 6.8.3.1. *Width:* when a single fog lamp is fitted its position in relation to the median longitudinal plane of the vehicle must be on the side opposite that required for the rule of the road in the Member State where it is to be registered.
- 6.8.3.2. *Height:* minimum 250 mm, maximum 900 mm above the ground.
- 6.8.3.3. *Length:* at the rear of the vehicle.
- 6.8.3.4. The distance between the illuminating surface of the rear fog lamp and that of the stop lamp must be at least 100 mm.
- 6.8.4. *Geometrical visibility*
This is determined by the angles α and β as defined in section A 10 of Annex I:
 $\alpha = 5^\circ$ upwards and 5° downwards;
 $\beta = 25^\circ$ to the left and to the right.
- 6.8.5. *Position:* to the rear.
- 6.8.6. May be grouped with any other rear lamp.
- 6.8.7. May not be combined with any other lamp.
- 6.8.8. May be reciprocally incorporated with a rear position lamp.
- 6.8.9. *Electrical connections*
The lamp may not be lit unless one or more of the following lamps are lit: the main-beam headlamp, the dipped-beam headlamp or the front fog lamp.
If there is a front fog lamp, it must be possible to switch off the rear fog lamp independently of the front fog lamp.
- 6.8.10. *Circuit-closed telltale:* compulsory.
Non-flashing amber indicator light.
- 6.8.11. *Other requirements:* none.

- 6.9. **Hazard warning signal**
- 6.9.1. Requirements identical to those set out in sections 6.3. to 6.3.8.
- 6.9.2. *Electrical connections*
The signal must be actuated by a separate control which enables all of the direction indicators to be supplied with current simultaneously.
- 6.9.3. *Circuit-closed telltale: compulsory.*
A red flashing light or, if there is not a separate telltale, the simultaneous operation of the telltales specified in 6.3.10.
- 6.9.4. *Other requirements*
A light flashing at the frequency of 90 ± 30 times per minute.
Actuation of the light-signalling device must be followed by illumination of the lamp within a maximum of one second and initial extinction of the lamp within a maximum of one-and-a-half seconds.
It must be possible to actuate the hazard warning signal even if the device for switching the engine on or off is in a position such that it is impossible for the latter to operate.
- 6.10. **Rear registration plate lamp**
- 6.10.1. *Number: one.*
The lamp may consist of several optical elements intended to illuminate the position of the plate.
- 6.10.2. *Arrangement drawing*
- 6.10.3. *Position*
- 6.10.3.1. *Width*
- 6.10.3.2. *Height*
- 6.10.3.3. *Length*
- 6.10.4. *Geometric visibility*
- 6.10.5. *Position*
- 6.10.6. May be grouped with one or more rear lamps.
- 6.10.7. May be combined with the rear position lamp.
- 6.10.8. May not be reciprocally incorporated with any other lamp.
- 6.10.9. Electrical connections: no individual specifications.
- 6.10.10. *Circuit-closed telltale: optional.*
Its operation must be ensured by the same telltale as provided for the position lamp.
- 6.10.11. *Other requirements: none.*
- 6.11. **Non-triangular side retro-reflectors**
- 6.11.1. *Number per side: one or two class IA (1).*
- 6.11.2. *Arrangement drawing: no individual specifications.*
- 6.11.3. *Position*
- 6.11.3.1. *Width: no individual specifications.*
- 6.11.3.2. *Height: 300 mm minimum, 900 mm maximum above the ground.*
- 6.11.3.3. *Length: must be such that, under normal conditions, the device cannot be masked by the driver or the passenger, nor by their clothing.*

} Such that the lamp illuminates the position reserved for the registration plate.

(1) In accordance with the classification set out in Directive 76/757/EEC.

- 6.11.4. *Geometric visibility*
Horizontal angles: 30° towards the front and rear.
Vertical angles: 15° above and below the horizontal.
However, the vertical angle below the horizontal may be reduced to 5° if the height of the retro-reflector is less than 750 mm.
- 6.11.5. *Position*: the reference axis of the retro-reflectors must be perpendicular to the median longitudinal plane of the vehicle and positioned outwards. Retro-reflectors at the front may move in line with the steering angle.
- 6.11.6. May be grouped with the other signalling devices.
- 6.12. **Non-triangular rear retro-reflectors**
- 6.12.1. *Number*: two, class IA ⁽¹⁾.
- 6.12.2. *Arrangement drawing*: no individual specifications.
- 6.12.3. *Location*
- 6.12.3.1. *Width*:
— the edges of the illuminating surfaces furthest from the median longitudinal plane of the vehicle must not be more than 400 mm from the outermost edge of the vehicle,
— the inner edges of the reflectors must be at least 500 mm apart. That distance may be reduced to 400 mm if the maximum width of the vehicle is less than 1 300 mm.
- 6.12.3.2. *Height*: minimum 250 mm, maximum 900 mm above the ground.
- 6.12.3.3. *Length*: to the rear of the vehicle.
- 6.12.4. *Geometrical visibility*
Horizontal angle: 30° to the outside and 10° to the inside.
Vertical angle: 15° above and below the horizontal.
However, the vertical angle below the horizontal may be reduced to 5° if the height of the retro-reflector is less than 750 mm.
- 6.12.5. *Location*: to the rear.
- 6.12.6. May be grouped with any other lamp.
- 6.12.7. The illuminating surface of the retro-reflector may have parts in common with any other red rear lamp.

⁽¹⁾ In accordance with the classification set out in Directive 76/757/EEC.

Appendix 1

Visibility of red lights towards the front and white lights towards the rear
(See point B.9 in Annex I and point 6.3.11.4.2 in this Annex)

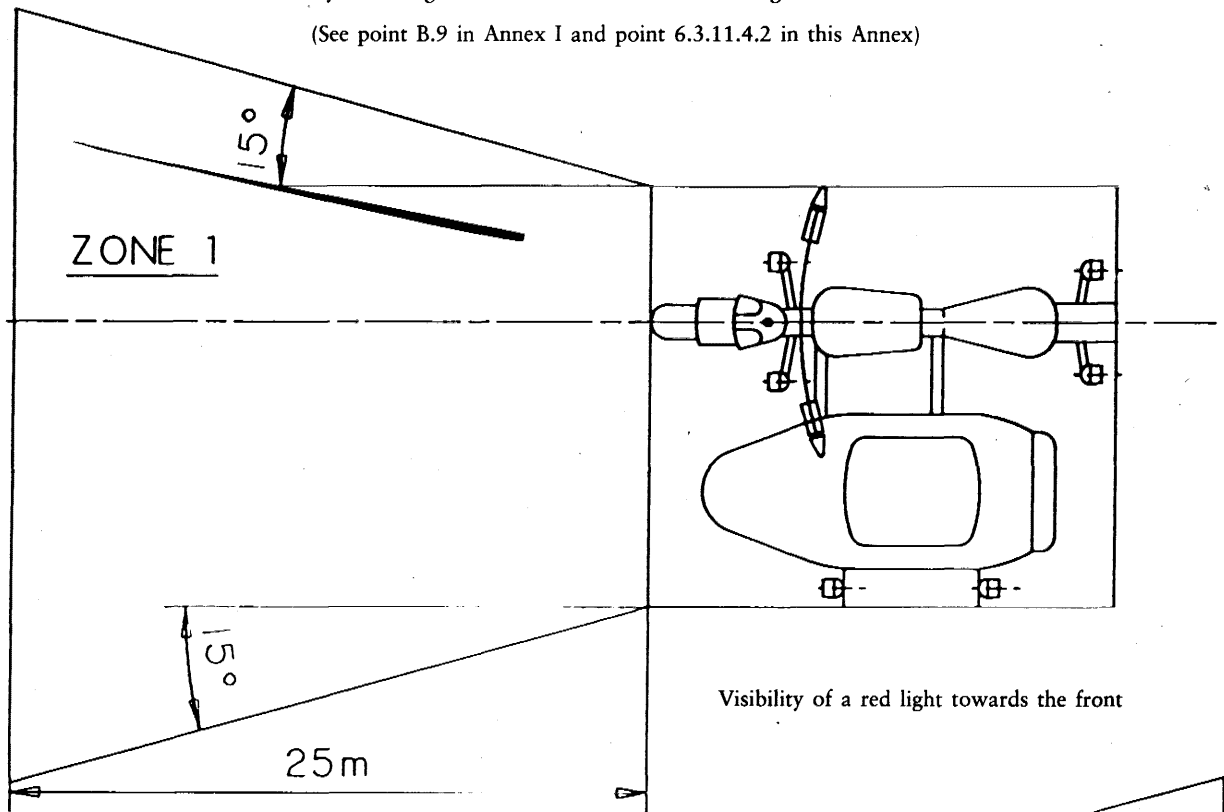

Figure 1

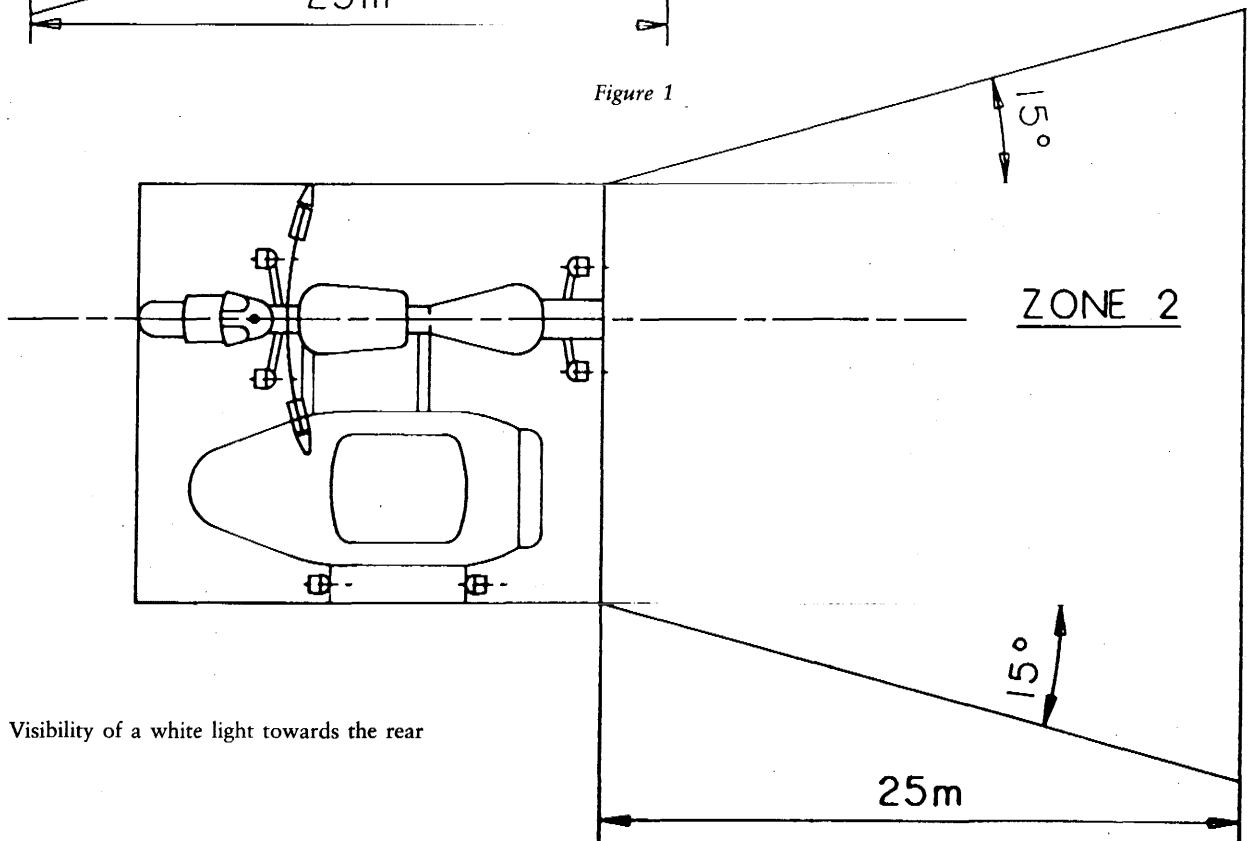
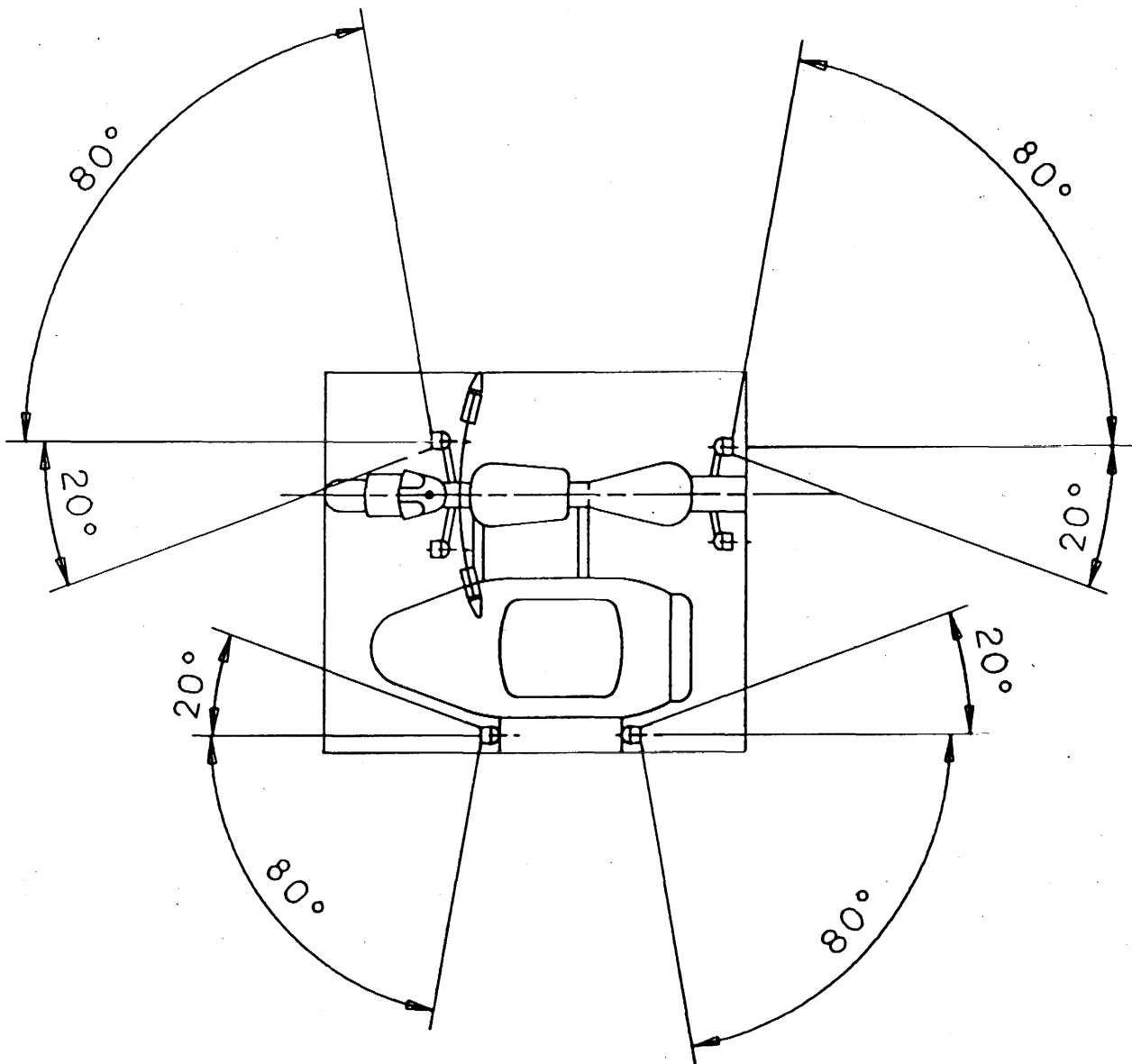

Figure 2

Appendix 2

Arrangement drawing

Two direction indicator lamps at the front and rear



Appendix 3

Information document in respect of the installation of lighting and light-signalling devices on a type of motorcycle with side-car

(To be attached to the component type-approval application where this is submitted separately from the vehicle type-approval application)

Reference number (allocated by the applicant):

The application for component type approval in respect of the installation of the lighting and light-signalling devices on a type of motor-cycle combination shall contain the information set out in Annex II to Directive 92/61/EEC under A, points:

- 0.1,
- 0.2,
- 0.4 to 0.6,
- 8 to 8.4.

Appendix 4

Name of administration

Component type-approval certificate in respect of the installation of lighting and light-signalling devices on a type of motorcycle with side-car

MODEL

- Report No by technical service on (date)
- Component type-approval No Extension No
- 1. Make (trade name) of vehicle
- 2. Vehicle type
- 3. Manufacturer's name and address
- 4. Name and address of manufacturer's representative (if any)
- 5. Mandatory lighting equipment installed on the vehicle submitted for checks (1):
- 5.1. Main-beam headlamps
- 5.2. Dipped-beam headlamps
- 5.3. Direction indicator lamps
- 5.4. Stop lamps
- 5.5. Front position lamps
- 5.6. Rear position lamps
- 5.7. Rear registration plate lamp
- 5.8. Non-triangular rear retro-reflectors
- 6. Optional lighting devices fitted to the vehicle submitted for checks (1):
- 6.1. Front fog lamps: yes/no (*)
- 6.2. Rear fog lamps: yes/no (*)
- 6.3. Hazard warning signal: yes/no (*)
- 6.4. Non-triangular side retro-reflectors: yes/no (*)
- 7. Variants:
- 8. Vehicle submitted for component type-approval on (date)
- 9. Component type-approval has been granted/refused (*)
- 10. Place
- 11. Date
- 12. Signature

(1) State on a separate sheet for each device the duly identified types of devices meeting the fitting requirements of this Annex.

(*) Delete as appropriate.

ANNEX VI

REQUIREMENTS CONCERNING TRICYCLES

1. All tricycles must be fitted with the following lighting and light-signalling devices:
 - 1.1. main-beam headlamp;
 - 1.2. dipped-beam headlamp;
 - 1.3. direction indicator lamps;
 - 1.4. stop lamp;
 - 1.5. front position lamp;
 - 1.6. rear position lamp;
 - 1.7. rear registration plate lamp;
 - 1.8. non-triangular rear retro-reflector;
 - 1.9. hazard warning signal.
2. In addition all tricycles may be fitted with the following lighting and light-signalling devices:
 - 2.1. front fog lamp;
 - 2.2. rear fog lamp;
 - 2.3. reversing lamp;
 - 2.4. non-triangular side retro-reflectors.
3. Each of the lighting and light-signalling devices referred to in sections 1 and 2 must be fitted in accordance with the appropriate provisions of section 6 below.
4. No lighting and light-signalling device other than those referred to in sections 1 and 2 may be fitted.
5. Lighting and light-signalling devices type-approved for four-wheel motor vehicles of categories M₁ and N₁ and referred to in sections 1 and 2 above may also be fitted to tricycles.
6. **SPECIFIC FITTING REQUIREMENTS**
 - 6.1. **Main-beam headlamps**
 - 6.1.1. *Number:* one or two.

However, for tricycles with a maximum width exceeding 1 300 mm, two main-beam headlamps are required.
 - 6.1.2. *Arrangement drawing:* no individual specifications
 - 6.1.3. *Location*
 - 6.1.3.1. *Width:*
 - an independent main-beam headlamp may be fitted above, below or to one side of another front lamp: if these lamps are one above the other the reference centre of the main-beam headlamp must be located within the median longitudinal plane of the vehicle; if these lamps are side by side their reference centre must be symmetrical in relation to the median longitudinal plane of the vehicle,
 - a main-beam headlamp that is reciprocally incorporated with another front lamp must be fitted in such a way that its reference centre lies within the median longitudinal plane of the vehicle. However, when the vehicle is also fitted with an independent dipped-beam headlamp alongside the main-beam headlamp, their reference centres must be symmetrical in relation to the median longitudinal plane of the vehicle,

— two main-beam headlamps of which either one or both are reciprocally incorporated with another front lamp must be fitted in such a way that their reference centres are symmetrical in relation of the median longitudinal plane of the vehicle.

6.1.3.2 The length: at the front of the vehicle. This requirement is considered to have been met if the light emitted does not disturb the driver either directly or indirectly by means of the rear-view mirrors and/or other reflective surfaces on the vehicle.

6.1.3.3 In any case, the distance between the edge of the illuminating surface of any independent main-beam headlamp and the edge of that of the dipped-beam headlamp must not exceed 200 mm.

6.1.4. *Geometrical visibility*

Even in the zones which do not seem to be illuminated in the direction of observation under consideration, the illuminating surface must be visible within a divergent area limited by generatrices touching the entire contour of the illuminating surface and forming an angle of 5° at least with the headlamp reference axis. The contour of the projection of the illuminating surface on to a transverse plane that is tangent to the front part of the main-beam headlamp lens is considered to be the origin of the angles of geometrical visibility.

6.1.5. *Alignment: forwards.*

May move in line with the steering angle.

6.1.6. May be grouped together with the dipped-beam headlamp and the other front lamps.

6.1.7. May not be combined with any other lamp.

6.1.8. May be reciprocally incorporated:

6.1.8.1. with the dipped-beam headlamp;

6.1.8.2. with the front position lamp;

6.1.8.3. with the front fog lamp.

6.1.9. *Electrical connections*

The main-beam headlamps must switch on simultaneously. When switching from the dipped to the main beam all of the main-beam headlamps must be lit. When switching from the main beam to the dipped beams all of the main-beam headlamps must be switched off simultaneously. The dipped-beam headlamps may remain lit at the same time as the main-beam headlamps.

6.1.10. *Circuit-closed telltale: optional.*

Blue non-flashing warning light.

6.1.11. Other requirements: the maximum intensity of the main-beam headlamps which can be switched on at the same time must not exceed 225 000 cd (component type-approval value).

6.2. **Dipped-beam headlamps**

6.2.1. *Number: one or two.*

However, for tricycles with a maximum width exceeding 1 300 mm two dipped-beam headlamps are required.

6.2.2. *Arrangement drawing: no individual specifications.*

6.2.3. *Position*

6.2.3.1. *Width:*

— an independent dipped-beam headlamp may be installed above, below or to one side of another front lamp: if these lamps are one above the other the reference centre of the dipped-beam headlamp must be located in the median longitudinal plane of the vehicle; if these lamps are side by side their reference centres must be symmetrical in relation to the median longitudinal plane of the vehicle,

— a dipped-beam headlamp that is reciprocally incorporated with another front lamp must be installed in such a way that its reference centre lies within the median longitudinal plane of the vehicle. However, where the vehicle is also fitted with an independent main-beam headlamp alongside the dipped-beam headlamp, their reference centres must be symmetrical in relation to the median longitudinal plane of the vehicle,

- two dipped-beam headlamps, of which either one or both are reciprocally incorporated with another front lamp must be installed in such a way that their reference centres are symmetrical in relation to the median longitudinal plane of the vehicle.

In the case of a vehicle with two dipped-beam headlamps:

- the edges of the illuminating surfaces furthestmost from the median longitudinal plane of the vehicle must not be more than 400 mm from the outermost edge of the vehicle,
- the innermost edges of the illuminating surfaces must be at least 500 mm apart. This distance may be reduced to 400 mm if the maximum width of the vehicle is less than 1 300 mm.

6.2.3.2. Height: a minimum of 500 mm and a maximum of 1 200 mm above the ground.

6.2.3.3. Length: at the front of the vehicle. This requirement is considered to have been met if the light emitted does not disturb the driver either directly or indirectly by means of the rear-view mirrors and/or other reflective surfaces of the vehicle.

6.2.4. *Geometric visibility*

Determined by angles α and β as specified in section A 10 of Annex I:

α = 15° upwards and 10° downwards;

β = 45° to the left and to the right if there is only one dipped-beam headlamp. 45° outwards and 10° inwards if there are two dipped-beam headlamps.

The presence of panels or other items of equipment near the light must not give rise to secondary effects causing discomfort to other road users.

6.2.5. *Alignment: forwards.*

May move in line with the steering angle.

The vertical inclination of the dipped beam must remain between -0,5 and -2,5 %, except in the case where an external adjusting device is present.

6.2.6. May be grouped together with the main-headlamp and the other front lamps.

6.2.7. May not be combined with any other lamp.

6.2.8. May be reciprocally incorporated with the main-beam headlamp and the other front lamps.

6.2.9. *Electrical connections*

The control for changing to the dipped beam must switch off all main-beam headlamps simultaneously, whereas the dipped beams may remain switched on at the same time as the main beam.

6.2.10. *Circuit-closed telltale: optional.*

Green non-flashing indicator light.

6.2.11. *Other requirements: none.*

6.3. *Direction indicator lamps*

6.3.1. *Number: two per side.*

One side direction indicator is also permitted per side.

6.3.2. *Arrangement drawing: two front and two rear indicator lamps.*

6.3.3. *Position*

6.3.3.1. *Width:*

- the edges of the illuminating surfaces furthest from the median longitudinal plane must not be more than 400 mm from the outermost part of the vehicle,
- the internal edges of the illuminating surfaces must be at least 500 mm apart,
- there must be a minimum distance between the illuminating surfaces of the indicators and the nearest dipped-beam headlamps of:

- 75 mm in the case of a minimum indicator intensity of 90 cd,
 - 40 mm in the case of a minimum indicator intensity of 175 cd,
 - 20 mm in the case of a minimum indicator intensity of 250 cd,
 - ≤ 20 mm in the case of a minimum indicator intensity of 400 cd.
- 6.3.3.2. Height: a minimum of 350 mm and a maximum of 1 500 mm above the ground.
- 6.3.4. *Geometric visibility*
- Horizontal angles: see Appendix 2.
- Vertical angles: 15° above and below the horizontal.
- However, the vertical angle below the horizontal may be reduced to 5° if the lamps are less than 750 mm above the ground.
- 6.3.5. *Alignment*
- The direction indicator lamps may move in line with the steering angle.
- 6.3.6. May be grouped with one or more lamps.
- 6.3.7. May not be combined with any other lamp.
- 6.3.8. May not be reciprocally incorporated with any other lamp.
- 6.3.9. *Electrical connections:*
- Direction indicator lamps must switch on independently of the other lamps. All direction indicator lamps on one side of a vehicle must be switched on and off by means of one control.
- 6.3.10. *Operational telltale:* optional.
- This may be optical or auditory or both. If it is optical it must be green flashing light visible under all normal operating conditions. It must be extinguished or remain alight without flashing or show a marked change of frequency in the event of the malfunction of any of the direction indicator lamps. If it is entirely auditory it must be clearly audible and show a marked change of frequency in the event of any malfunction.
- 6.3.11. *Other requirements*
- The characteristics listed below must be measured with the electrical generator supplying current only to those circuits that are essential to the operation of the engine and lighting devices.
- 6.3.11.1. Actuation of the light-signalling device control must be followed by illumination of the lamp within a maximum of one second and initial extinction of the lamp within a maximum of one-and-a-half seconds.
- 6.3.11.2. In the case of all vehicles the direction indicator lamps of which are supplied with direct current:
- 6.3.11.2.1. the flashing-light frequency must be 90 ± 30 times per minute;
 - 6.3.11.2.2. the direction indicator lamps on the same side of the vehicle must flash at the same frequency and in phase.
- 6.3.11.3. Where a vehicle is fitted with direction indicator lamps which are supplied with alternating current, when the engine speed lies between 50 and 100 % of the speed corresponding to the maximum speed of the vehicle:
- 6.3.11.3.1. the lights must flash at a frequency of 90 ± 30 times per minute;
 - 6.3.11.3.2. the direction indicator lamps may flash on the same side of the vehicle either simultaneously or alternately. The front lamps must not be visible to the rear nor the rear lamps to the front within the zones defined in Appendix 1.
- 6.3.11.4. Where the direction indicator lamps fitted to a vehicle are supplied with alternating current, when the engine speed lies between the idling speed specified by the manufacturer and 50 % of the speed corresponding to the maximum speed of the vehicle:
- 6.3.11.4.1. the flashing frequency must lie between $90 + 30$ and $90 - 45$ times per minute;
 - 6.3.11.4.2. direction indicator lamps on the same side of the vehicle may flash either simultaneously or alternately. The front lamps must not be visible to the rear, nor the rear lamps visible to the front within the zones defined in Appendix 1.

- 6.3.11.5. In the event of failure, other than a short circuit, of one direction indicator lamp, the other must continue to flash, or remain lit, but the frequency in this state may be different from that specified, unless the vehicle is fitted with a telltale.
- 6.4. **Stop lamps**
- 6.4.1. *Number:* one or two.
- However, for tricycles with a maximum width exceeding 1 300 mm, two stop lamps are required.
- 6.4.2. *Arrangement drawing:* no individual specifications.
- 6.4.3. *Position*
- 6.4.3.1. *Width:* if there is only one stop lamp its centre of reference must lie within the median longitudinal plane of the vehicle, or if there are two stop lamps they must be symmetrical to the median longitudinal plane of the vehicle.
- In the case of vehicles with two rear wheels: at least 600 mm between the two lamps. The distance may be reduced to 400 mm of the maximum width if the vehicle is less than 1 300 mm.
- 6.4.3.2. *Height:* minimum 250 mm, maximum 1 500 mm above ground.
- 6.4.3.3. *Length:* at the rear of the vehicle.
- 6.4.4. *Geometric visibility:*
- Horizontal angle: 45° to the left and to the right.
- Vertical angle: 15° above and below the horizontal.
- However, the vertical angle below the horizontal may be reduced to 5° if the lamp is less than 750 mm above the ground.
- 6.4.5. *Alignment:* towards the rear of the vehicle.
- 6.4.6. May be grouped with one or more other rear lamps.
- 6.4.7. May not be combined with any other lamp.
- 6.4.8. May be reciprocally incorporated with the rear position lamp.
- 6.4.9. *Electrical connection:* must light up whenever at least one of the service brakes is applied.
- 6.4.10. *Circuit-closed telltale:* prohibited.
- 6.5. **Front position lamps**
- 6.5.1. *Number:* one or two.
- However, in the case of tricycles with a maximum width exceeding 1 300 mm, two front position lamps are required.
- 6.5.2. *Arrangement drawing:* no individual specifications.
- 6.5.3. *Position*
- 6.5.3.1. *Width:*
- one independent front position lamp may be fitted above or below or to one side of another front lamp: if these lamps are one above the other the reference centre of the main-beam headlamp must be located within the median longitudinal plane of the vehicle; if these lamps are side by side their reference centres must be symmetrical in relation to the median longitudinal plane of the vehicle,
 - a front position lamp that is reciprocally incorporated with another front lamp must be installed in such a way that its reference centre is situated in the median longitudinal plane of the vehicle,
 - two front position lamps, of which one or both are combined with another front lamp, must be installed in such a way that their reference centres are symmetrical in relation to the median longitudinal plane of the vehicle.

In the case of a vehicle with two front position lamps:

- the edges of the illuminating surfaces furthest from the median longitudinal plane of the vehicle must not be more than 400 mm from the outermost part of the vehicle,
- the internal edges of the illuminating surfaces must be at least 500 mm apart.

6.5.3.2. Height: minimum 350 mm, maximum 1 200 mm above the ground.

6.5.3.3. Length: at front of vehicle.

6.5.4. *Geometric visibility*

Horizontal angle: 80° to the left and right if there is a single position lamp; 80° to the outside and 45° to the inside, if there are two position lamps.

Vertical angle: 15° above and below the horizontal.

However, the vertical angle below the horizontal may be reduced to 5° if the lamp is less than 750 mm above the ground.

6.5.5. *Alignment*: towards the front.

May move in line with the steering angle.

6.5.6. May be grouped with any other front lamp.

6.5.7. May be reciprocally incorporated with any other front lamp.

6.5.8. *Electrical connections*: no individual specifications.

6.5.9. *Circuit-closed telltale*: compulsory.

Non-flashing green pilot light; this telltale is not required where the dashboard lighting can only be switched on and off simultaneously with the position lamp.

6.5.10. Other requirements: none.

6.6. **Rear position lamps**

6.6.1. *Number*: one or two.

However, for tricycles with a maximum width exceeding 1 300 mm, two rear position lamps are required.

6.6.2. *Arrangement drawing*: no individual specifications.

6.6.3. *Position*

6.6.3.1. Width: the reference centre must be located within the median longitudinal plane of the vehicle, if there is only one position lamp or, if there are two position lamps, they must be symmetrical to the median longitudinal plane of the vehicle. In the case of vehicles with two rear wheels these must be at least 600 mm apart. This distance must be reduced to 400 mm if the maximum width of the vehicle is less than 1 300 mm.

6.6.3.2. Height: minimum 250 mm, maximum 1 500 mm above the ground.

6.6.3.3. Length: at rear of vehicle.

6.6.4. *Geometric visibility*

Horizontal angle: 80° to the left and right if there is a single position lamp; 80° to the outside and 45° to the inside, if there are two position lamps.

Vertical angle: 15° above and below the horizontal.

However, the vertical angle below the horizontal may be reduced to 5° if the lamp is less than 750 mm above the ground.

6.6.5. *Alignment*: towards the rear.

6.6.6. May be grouped with any other rear lamp.

6.6.7. May be combined with the rear registration plate lamp.

6.6.8. May be reciprocally incorporated with the stop lamp or non-triangular rear retro-reflector, or with both, or with the rear fog lamp.

6.6.9. *Electrical connections*: no individual specifications.

- 6.6.10. *Circuit-closed telltale*: optional.
Its function may be fulfilled by the device provided, where appropriate, for the front position lamp.
- 6.6.11. *Other requirements*: none.
- 6.7. **Front fog lamps**
- 6.7.1. *Number*: one or two.
- 6.7.2. *Arrangement drawing*: no individual specifications.
- 6.7.3. *Position*
- 6.7.3.1. *Width*:
- a front fog lamp may be installed above, below or next to another front lamp; if these lamps are on top of each other, the reference centre of the front fog lamp must be located within the median longitudinal plane of the vehicle; if the two lamps are side by side, their reference centres must be symmetrical in relation to the median longitudinal plane of the vehicle,
 - a front fog lamp that is reciprocally incorporated with another front lamp must be installed in such a way that its reference centre is situated in the median longitudinal plane of the vehicle,
 - two front fog lamps, one or both of them, reciprocally incorporated with another front lamp, must be installed in such a way that their reference centres are symmetrical in relation to the median longitudinal plane of the vehicle.
 - the edges of the illuminating surface furthest from the median longitudinal plane of the vehicle must not be further than 400 mm from the outermost edge of the vehicle.
- 6.7.3.2. *Height*: 250 mm minimum above the ground. No point of the illuminating surface must be above the highest point of the illuminating surface of the dipped-beam headlamp.
- 6.7.3.3. *Length*: at the front of the vehicle, this requirement is considered to have been met if the light emitted does not disturb the driver, either directly or indirectly by means of the rear-view mirrors and/or other reflective surfaces of the vehicle.
- 6.7.4. *Geometric visibility*
- This is determined by the angles α and β as defined in section A 10 of Annex I:
- $\alpha = 5^\circ$ upwards and downwards;
- $\beta = 45^\circ$ to the left and to the right in the case of a non-central lamp, in which case the internal angle must be $\beta = 10^\circ$.
- 6.7.5. *Alignment*: towards the front.
May move in line with the steering angle.
- 6.7.6. May be grouped with the other front lamps.
- 6.7.7. May not be combined with any other front lamp.
- 6.7.8. May be reciprocally incorporated with a main-beam headlamp and a front position lamp.
- 6.7.9. *Electrical connections*
- It must be possible to switch the front fog lamp on or off independently of the main-beam headlamp or the dipped-beam lamp.
- 6.7.10. *Circuit-closed telltale*: optional.
Green non-flashing indicator light.
- 6.7.11. *Other requirements*: none.
- 6.8. **Rear fog lamps**
- 6.8.1. *Number*: one or two.
- 6.8.2. *Arrangement drawing*: no individual specifications.

- 6.8.3. Position
- 6.8.3.1. Width: the reference centre must be situated in the median longitudinal plane of the vehicle if there is a single fog lamp or, if there are two fog lamps, they must be symmetrical in relation to the median longitudinal plane of the vehicle. In the case of vehicles with two rear wheels: at least 600 mm between the two lamps. This distance may be reduced to 400 mm if the maximum width of the vehicle is less than 1 300 mm.
- 6.8.3.2. Height: minimum 250 mm, maximum 1 000 mm above the ground.
- 6.8.3.3. Length: at the rear of the vehicle. If there is a single fog lamp, it must be on the side of the median longitudinal plane of the vehicle opposite the normal direction of travel; the reference centre may also be situated on the longitudinal plane of symmetry of the vehicle.
- 6.8.3.4. The distance between the illuminating surface of the rear fog lamp and that of the stop lamp must be at least 100 mm.
- 6.8.4. *Geometrical visibility*
This is determined by the angles α and β as defined in section A 10 of Annex I:
 $\alpha = 5^\circ$ upwards and 5° downwards;
 $\beta = 25^\circ$ to the left and to the right.
- 6.8.5. *Position*: to the rear.
- 6.8.6. May be grouped with any other rear lamp.
- 6.8.7. May not be combined with any other lamp.
- 6.8.8. May be reciprocally incorporated with a rear position lamp.
- 6.8.9. *Electrical connections*
The lamp may not be lit unless one or more of the following lamps are lit: the main-beam headlamp, the dipped-beam headlamp or the front fog lamp.
- 6.8.10. *Circuit-closed telltale*: compulsory.
Non-flashing amber indicator light.
- 6.8.11. *Other requirements*: none.
- 6.9. Reversing lamps
- 6.9.1. *Number*: one or two.
- 6.9.2. *Arrangement drawing*: no individual specifications.
- 6.9.3. *Position*
- 6.9.3.1. Width: no individual specifications.
- 6.9.3.2. Height: minimum 250 mm, maximum 1 200 mm above the grounds.
- 6.9.3.3. Length: at the rear of the vehicle.
- 6.9.4. *Geometric visibility*
This is determined by the angles α and β as specified in section A 10 of Annex I:
 $\alpha = 15^\circ$ upwards and 5° downwards;
 $\beta = 45^\circ$ to the right and to the left if there is only one lamp;
 $\beta = 45^\circ$ outwards and 30° inwards if there a two lamps.
- 6.9.5. *Alignment*: towards the rear.
- 6.9.6. May be grouped with any other rear lamp.
- 6.9.7. May not be combined with any other lamp.
- 6.9.8. May not be reciprocally incorporated with another lamp.

- 6.9.9. *Electrical connections*
The lamp may not be alight unless the reverse gear is engaged and the device for switching off the engine is in a position such that it is possible for the engine to operate.
It must not be possible for the lamp to be alight or remain lit if one of these conditions is unverified.
- 6.9.10. *Circuit-closed telltale*: optional.
- 6.10. **Hazard warning signal**
- 6.10.1. Requirements identical to those set out in sections 6.3 to 6.3.8.
- 6.10.2. *Electrical connections*
The signal must be actuated by a separate control which enables all of the direction indicators to be supplied with current simultaneously.
- 6.10.3. *Circuit-closed telltale*: compulsory.
A red flashing light or, if there is no separate telltale, the simultaneous operation of the telltales specified in 6.3.10.
- 6.10.4. *Other requirements*
A light flashing at a frequency of 90 ± 30 times per minute. Actuation of the light-signalling device must be followed by illumination of the lamp within a maximum of one second and initial extinction of the lamp within a maximum of one-and-a-half seconds.
It must be possible to actuate the hazard warning signal even if the device for switching the engine on or off is in a position such that it is impossible for the later to operate.
- 6.11. **Rear registration plate lamp**
- 6.11.1. *Number*: one.
The lamp may consist of several optical elements intended to illuminate the position of the plate.
- 6.11.2. *Arrangement drawing*
- 6.11.3. *Position*
- 6.11.3.1. Width
- 6.11.3.2. Height
- 6.11.3.3. Length
- 6.11.4. *Geometric visibility*
- 6.11.5. *Position*
- 6.11.6. May be grouped with one or more rear lamps.
- 6.11.7. May be combined with the rear position lamp.
- 6.11.8. May not be reciprocally incorporated with any other lamp.
- 6.11.9. Electrical connections: no individual specifications.
- 6.11.10. *Circuit-closed telltale*: optional.
Its operation must be ensured by the same telltale as provided for the position lamp.
- 6.11.11. *Other requirements*: none.
- 6.12. **Non-triangular rear retro-reflectors**
- 6.12.1. *Number*: one or two class IA ⁽¹⁾.
However, in the case of tricycles with a maximum width exceeding 1 000 mm, two non-triangular rear reflectors are required.

} Such that the lamp illuminates the position reserved for the registration plate.

⁽¹⁾ In accordance with the classification set out in Directive 76/757/EEC.

- 6.12.2. *Arrangement drawing*: no individual specifications.
- 6.12.3. *Position*
- 6.12.3.1. Width: the reference centre must be situated in the median longitudinal plane of the vehicle if there is a single retro-reflector or, if there are two retro-reflectors, they must be symmetrical to the median longitudinal plane of the vehicle. In the case of a vehicle with two rear retro-reflectors, the edges of the illuminating surface furthest from the median longitudinal plane of the vehicle must not be more than 400 mm from the outermost part of the vehicle. The internal edges of the retro-reflectors must be at least 500 mm apart.
- This distance may be reduced to 400 mm if the maximum width of the vehicle is less than 1 300 mm.
- 6.12.3.2. Height: 250 mm minimum, 900 mm maximum above the ground.
- 5.12.3.3. Length: at the rear of the vehicle.
- 6.12.4. *Geometric visibility*
- Horizontal angle: 30° to the left and to the right.
- Vertical angle: 15° above and below the horizontal. However, the vertical angle below the horizontal may be reduced to 5° if the height of the retro-reflector is less than 750 mm.
- 6.12.5. *Alignment*: to the rear.
- 6.12.6. May be grouped with any other lamp.
- 6.12.7. *Other requirements*: the illuminating surface of the retro-reflector may have parts in common with any other red rear lamp situated at the rear.
- 6.13. **Non-triangular side retro-reflectors**
- 6.13.1. *Number per side*: one or two class IA (1).
- 6.13.2. *Arrangement drawing*: no individual specifications.
- 6.13.3. *Position*
- 6.13.3.1. Width: no individual specifications.
- 6.13.3.2. Height: 300 mm minimum, 900 mm maximum above the ground.
- 6.13.3.3. Length: must be such that, under normal conditions, the device cannot be hidden by the driver or passenger, or by their clothing; masked by the driver or the passenger, nor by their clothing.
- 6.13.4. *Geometric visibility*
- Horizontal angles: 30° towards the front and rear.
- Vertical angles: 15° above and below the horizontal.
- However, the vertical angle below the horizontal may be reduced to 5° if the height of the retro-reflector is less than 750 mm.
- 6.13.5. *Position*: the reference axis of the retro-reflectors must be perpendicular to the median longitudinal plane of the vehicle and positioned outwards. Retro-reflectors at the front may move in line with the steering angle.
- 6.13.6. May be grouped with the other signalling devices.

(1) In accordance with the classification set out in Directive 76/757/EEC.

Appendix 1

Visibility of red lights towards the front and white lights towards the rear
(See point B.9 in Annex I and points 6.3.11.3.2 and 6.3.11.4.2 in this Annex)

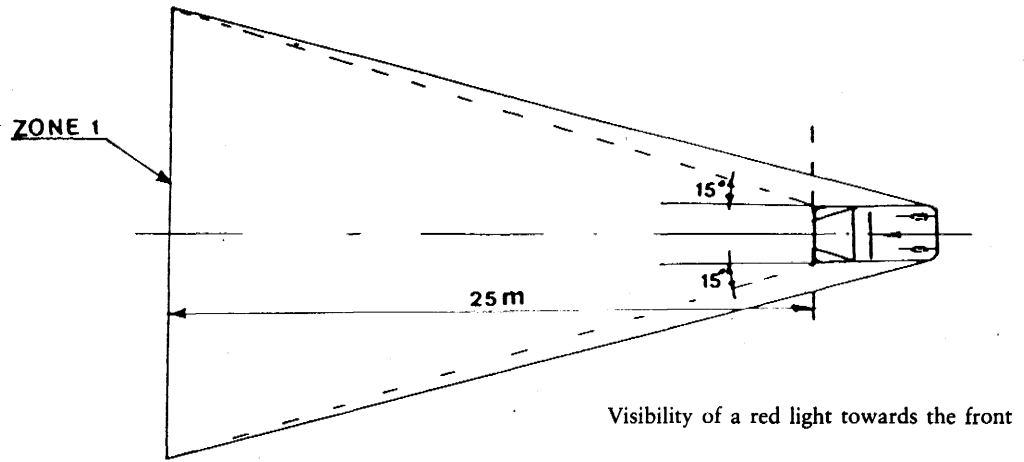

Figure 1

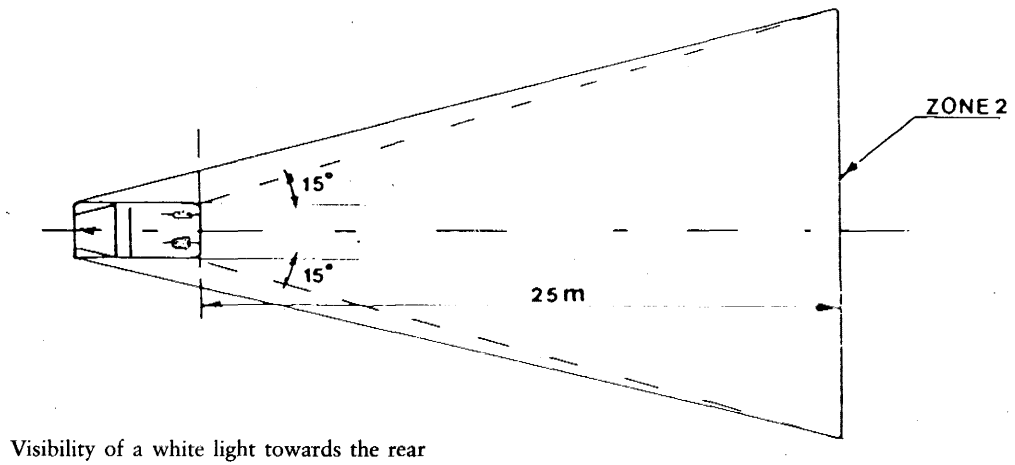
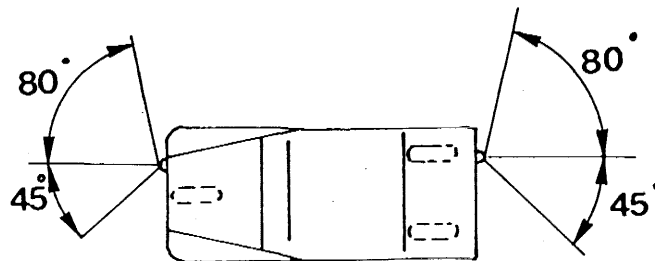

Figure 2

Appendix 2

Arrangement drawing

Direction indicator lamp — Geometric visibility



Appendix 3

Information document in respect of the installation of lighting and light-signalling devices on a type of tricycle

(To be attached to the component type-approval application where this is submitted separately from the vehicle type-approval application)

Reference number (allocated by the applicant):

The application for component type-approval in respect of the installation of lighting and light-signalling devices on a type of tricycle shall contain the information set out in Annex II to Directive 92/61/EEC under A, points:

- 0.1,
- 0.2,
- 0.4 to 0.6,
- 8 to 8.4.

Appendix 4

Name of administration

Component type-approval certificate in respect of the installation of lighting and light-signalling devices on a type of tricycle

MODEL

Report No by technical service on (date)

Component type-approval No Extension No

1. Make (trade name) of vehicle
2. Vehicle type
3. Manufacturer's name and address
4. Name and address of manufacturer's representative (if any)
5. Mandatory lighting equipment installed on the vehicle submitted for checks (1):
- 5.1. Main-beam headlamps
- 5.2. Dipped-beam headlamps
- 5.3. Direction indicator lamps
- 5.4. Stop lamps
- 5.5. Front position lamps
- 5.6. Rear position lamps
- 5.7. Rear registration plate lamp
- 5.8. Non-triangular rear retro-reflectors
6. Optional lighting fitted to the vehicle submitted for checks (1):
- 6.1. Front fog lamps: yes/no (*)
- 6.2. Rear fog lamps: yes/no (*)
- 6.3. Reversing lamp: yes/no (*)
- 6.4. Hazard warning signal: yes/no (*)
- 6.5. Non-triangular side retro-reflectors: yes/no (*)
7. Variants
8. Vehicle submitted for component type-approval on (date)
9. Component type-approval has been granted/refused (*)
10. Place
11. Date
12. Signature

(1) State on a separate sheet for each device the duly identified types of devices meeting the fitting requirements of this Annex.

(*) Delete as appropriate.