

COUNCIL DIRECTIVE

of 22 December 1986

on the approximation of the laws of the Member States relating to self-propelled industrial trucks

(86/663/EEC)

THE COUNCIL OF THE EUROPEAN COMMUNITIES,

Having regard to the Treaty establishing the European Economic Community, and in particular Article 100 thereof,

Having regard to the proposal from the Commission ⁽¹⁾,

Having regard to the opinion of the European Parliament ⁽²⁾,

Having regard to the opinion of the Economic and Social Committee ⁽³⁾,

Whereas in each Member State the design and construction of self-propelled industrial trucks are subject to safety provisions which differ from one Member State to another and consequently hinder trade in these appliances; whereas it is therefore necessary to approximate these provisions;

Whereas Council Directive 84/528/EEC of 17 September 1984 on the approximation of the laws of the Member States relating to common provisions for lifting and mechanical handling appliances ⁽⁴⁾ laid down a series of common procedures, such as EEC type-approval, EEC type-examination and EEC self-certification, for the placing on the market of these lifting and mechanical handling appliances; whereas, in the case of self-propelled industrial trucks, EEC self-certification should be provided for, as is the usual practice in the Member States;

Whereas this Directive is a separate Directive within the meaning of Article 2 (2) of Directive 84/528/EEC;

Whereas the technical provisions contained in Annex I do not preclude Community or national measures concerning other safety aspects of these industrial trucks such as the operator restraint system, electrical safety, traffic safety, safety when working in areas subject to explosion, exhaust emissions and noise;

Whereas, in the interests of greater safety, it would appear advisable to introduce provisions relating to the controls

and the fuel tank; whereas a transition period is justified in order to enable manufacturers to adapt their products to these new provisions;

Whereas technical progress necessitates rapid adaptation of the technical requirements; whereas the procedure laid down in Article 22 of Directive 84/528/EEC should therefore be adopted for such adaptations of this Directive;

Whereas certain provisions in Annex I should be excluded from the application of the derogating clause provided for in Article 23 of Directive 84/528/EEC;

Whereas the institution of examination and testing methods is an implementing measure of a technical nature and should therefore be adopted by the Commission in accordance with the procedure referred to above,

HAS ADOPTED THIS DIRECTIVE:

Article 1

1. This Directive shall apply to self-propelled industrial trucks, the capacity of which does not exceed 10 000 kilograms, and to tractors with a draw-bar pull of less than 20 000 newtons.

2. For the purpose of this Directive, 'self-propelled industrial truck' means any wheeled vehicle, other than those running on rails, that is designed to carry, tow, push, lift, stack or tier in racks any kind of load and is controlled by an operator who either walks with the truck or rides on a specially arranged driving platform which is either fixed to the chassis or can be raised.

Article 2

1. This Directive does not cover:

- (a) tipper vehicles (known as dumpers) or motor-driven barrows operating on building and construction sites;
- (b) tractors other than those referred to in Annex I, section 1.2, lorries with or without trailer, forestry and agricultural tractors, construction plant and trucks used in underground mining operations;
- (c) milk floats and similar delivery vehicles;

⁽¹⁾ OJ No C 165, 2. 7. 1979, p. 1.

⁽²⁾ OJ No C 197, 4. 8. 1980, p. 67.

⁽³⁾ OJ No C 182, 21. 7. 1980, p. 22.

⁽⁴⁾ OJ No L 300, 19. 11. 1984, p. 72.

- (d) stacking appliances which move only inside guides and are known as stacker cranes;
- (e) trucks with elevating operator position and rated load capacity exceeding 5 000 kilograms;
- (f) trucks specifically designed to travel with elevated loads exceeding 5 000 kilograms;
- (g) straddle carriers;
- (h) remote-controlled tractors and trucks not carrying an operator;
- (i) equipment used for elevated maintenance;
- (j) trucks powered by external forms of electrical energy;
- (k) mobile cranes;
- (l) mobile lifting platforms;
- (m) trucks with telescopic arms.

2. This Directive shall not preclude Community or national measures concerning the environment and other safety aspects of industrial trucks not covered by this Directive, such as:

- electrical equipment for use within specific voltage limits,
- road traffic,
- exhaust emissions,
- risks of operating in explosive atmospheres,
- noise at place of work and in the environment,
- operator restraint.

Article 3

Member States shall take all the necessary measures to ensure that self-propelled industrial trucks covered by this Directive cannot be placed on the market or put into service unless they satisfy the provisions of this Directive.

Article 4

The manufacturer or his authorized representative established in the Community shall certify on his own responsibility the conformity of each industrial truck with this Directive by means of a certificate of conformity, a specimen of which is reproduced in Annex II, and by affixing the conformity mark to the truck under the conditions laid down in Annex III.

Article 5

1. The manufacturer or his authorized representative established in the Community shall issue the certificate of conformity and affix the mark of conformity as laid down in Article 4 provided he is able to show that:

- he possesses the necessary means to carry out the tests referred to in Annex I, and where appropriate,
- he has arranged for such tests as are referred to in Annex I which are not performed by him to be carried out by one or more of the bodies approved for that purpose by the Member State.

2. The manufacturer or his authorized representative established in the Community shall hold at the disposal of the competent bodies of the Member State all documents showing that the tests laid down in Annex I have been performed and that the technical requirements have been complied with.

3. Each Member State shall forward to the other Member States and to the Commission:

- the list of approved bodies authorized to carry out the tests referred to in this Article,
- any subsequent amendments to that list.

Article 6

The Member State shall take all the necessary measures to ensure that the provisions of Article 5 are complied with.

Article 7

The Member State may carry out spot checks to verify whether the equipment referred to in Article 1 complies with the requirements of this Directive. However, such checks must not impose tests and requirements more stringent than those laid down in this Directive.

Article 8

Where the checks referred to in Article 7 show that a self-propelled industrial truck does not comply with the requirements of this Directive, the Member State shall take all the necessary steps to:

- prohibit its being placed on the market,
- prohibit its use,
- order its withdrawal from the market.

Where non-compliance is the result of a design fault or series production defect in the trucks which affect safety,

the Member State shall inform the other Member States and the Commission of the faults and/or defects noted and the measures taken.

The measures taken shall be revoked where it is proved that the truck complies with the requirements of the Directive.

Article 9

No Member State may, on grounds relating to the requirements referred to by this Directive, refuse, prohibit or restrict the placing on the market, entry into service or use for their intended purpose of industrial trucks which comply with the requirements of this Directive.

Article 10

Any amendments necessary to adapt Annex I to technical progress, with the exception of sections 9.12.1.1 and 9.12.1.2, shall be adopted in accordance with the procedure laid down in Article 22 of Directive 84/528/EEC.

Test and examination methods shall also be adopted and adapted to technical progress in accordance with that procedure.

The procedure laid down in Article 23 of Directive 84/528/EEC shall apply to Annex I.

Article 11

The provisions of this Directive shall not affect the Member States' entitlement to lay down, with due observance of the Treaty, the requirements they deem necessary to ensure that workers are protected when using the equipment in question, provided that this does not mean that the equipment is modified in a way not specified in the Directive.

Article 12

1. Member States shall adopt, publish and bring into force the laws, regulations and administrative provisions necessary in order to comply with this Directive by 1 January 1989. They shall forthwith inform the Commission thereof.

2. Member States shall ensure that the texts of the provisions of national law which they adopt in the field governed by this Directive are communicated to the Commission.

Article 13

This Directive is addressed to the Member States.

Done at Brussels, 22 December 1986.

For the Council

The President

G. SHAW

ANNEX I

TECHNICAL REQUIREMENTS FOR SELF-PROPELLED INDUSTRIAL TRUCKS

1. CLASSIFICATION OF TRUCKS BY MODE OF ACTION
 - 1.1. **Platform truck**

Truck carrying its load on a non-elevating platform or attachment.
 - 1.2. **Industrial tractor**

Industrial truck travelling on the ground, fitted with coupling means, and specially designed to draw vehicles travelling on the ground.
 - 1.3. **Shunting-tractor**

Tractor which, being fitted at the front end and/or rear with a buffer plate, can also push vehicles travelling on the ground or on railway track.
 - 1.4. **Lift-truck**

Industrial truck which is capable of raising, lowering and transporting loads.
 - 1.4.1. *Stacking lift-truck*

Truck fitted with a platform, a fork, or other load-handling devices, able to raise a load, either palletized or not, up to sufficient lift height to allow stacking or tiering in racks.
 - 1.4.1.1. Counterbalanced truck:

stacking lift-truck fitted with a fork on which the load, either palletized or not, is put in a cantilever position in relation with the front wheels and balanced by the mass of the truck.
 - 1.4.1.2. Reach truck with retractable mast or fork carriage:

stacking lift-truck with outriggers where the load can be placed in a cantilever position by extending the mast or the fork carriage.
 - 1.4.1.3. Straddle truck:

stacking lift-truck with outriggers, fitted with a fork located between the outriggers and where the centre of gravity of the load is always within the stability polygon.
 - 1.4.1.4. Pallet staker:

stacking lift-truck where the fork arms extend over the frame structure.
 - 1.4.1.5. Platform high-lift truck:

stacking lift-truck with a load platform extending over the frame structure.
 - 1.4.1.6. Truck with elevated operator:

stacking lift-truck, fitted with an operating position which can be raised with the load-carrying means (platform or fork) for stacking loads in racks.
 - 1.4.1.7. Side-loading truck:

fork truck the retractable mast of which is located between the axles and perpendicular to the longitudinal axis of the truck, allowing it to take and raise a load in a counterbalanced position in relation to one side of the truck and to place it on the integral load platform.
 - 1.4.1.8. Rough-terrain fork truck:

machine specially designed to load, lift, carry and stack loads on unprepared ground (large wheels, large ground clearance, special drive unit) fitted with a load-carrying device sliding vertically on a fixed or tilting mast.
 - 1.4.1.9. Lateral stacking truck:

stacking lift-truck capable of stacking and retrieving loads to one or both sides of the direction of travel.

- 1.4.1.10. Lateral and front stacking truck:
lift-truck capable of stacking and retrieving loads along and to one or both sides of the direction of travel.
- 1.4.2. *Low-lift non-stacking lift-truck*
Powered truck fitted with a platform, fork or other load-handling equipment and able to raise its load to a height just sufficient to allow its transportation.
- 1.4.2.1. Pallet truck:
non-stacking lift-truck, fitted with a fork for the handling of pallets.
- 1.4.2.2. Platform floor truck: non-stacking lift-truck fitted with a platform or other device for the transportation of loads.
- 1.4.2.3. Straddle carriers: lift-truck, where the frame and lift unit straddle the load to raise it and move it.
- 1.4.3. *High- and medium-lift order-picking trucks*
A truck with an elevatable platform for an operator and a device to accommodate the aggregated load (normally fork arms to accept a pallet or stillage) to facilitate picking (and occasional replacing) from stored goods.
Medium-lift designates trucks able to elevate the operator platform not more than 2,5 metres.
- 1.4.4. Straddle carriers: lift-truck where the frame and lift unit straddle the load to raise it, move it and stack it.
2. CLASSIFICATION OF TRUCKS BY MODE OF CONTROL ⁽¹⁾
3. CLASSIFICATION OF TRUCKS BY HEIGHT OF LIFT ⁽¹⁾
4. CLASSIFICATION OF TRUCKS BY MODE OF TRAVELLING ⁽¹⁾
5. CLASSIFICATION OF TRUCKS BY POWER SOURCE ⁽¹⁾
6. CLASSIFICATION OF TRUCKS BY TYPES OF WHEEL ⁽¹⁾
7. TERMINOLOGY OF THE MAIN COMPONENTS OF TRUCKS ⁽¹⁾
8. CAPACITY OF TRUCKS AND REMOVABLE ATTACHMENTS ⁽¹⁾
- 8.1. **High-lift trucks**
- 8.1.1. *Rated capacity of high-lift trucks*
The rated capacity of a self-propelled industrial high-lift truck is the load in kilograms, permitted by the manufacturer, that the truck type is capable of transporting or lifting in normal operation under specific conditions (see Addendum A).

⁽¹⁾ As included in ISO Standard 5053/I of 15 September 1980.

8.1.2. *Actual capacity of high-lift trucks*

The actual capacity of a self-propelled industrial high-lift truck is the maximum load in kilograms (depending on its attachment and elevating height), permitted by the manufacturer (usually by stability testing) that the subject truck is capable of transporting or lifting in normal operation under specific conditions (see Addendum A).

8.2. **Fixed-platform and low-lift trucks**8.2.1. *Rated capacity of fixed-platform and low-lift trucks*

The rated capacity of a fixed-platform or low-lift truck is the maximum load in kilograms permitted by the manufacturer uniformly distributed over the load-carrying platforms or device, which the truck is capable of transporting under normal conditions of operation.

8.3. **Industrial tractors**8.3.1. *Rated capacity of industrial tractors*

The rated capacity of an industrial tractor powered by an internal combustion engine is the horizontal draw-bar pull in newtons given by the manufacturer, that the industrial tractor can develop at a specified coupling height whilst moving at a uniform speed of not less than 10 % of the maximum no-load speed, on a smooth, dry and horizontal concrete surface. In the case of electrically powered tractors or tractors fitted with a torque convertor the rated capacity is the capacity developed during one hour's operation. For stand-on or sit-on industrial tractors the driver's mass is to be 90 kilograms (ballasted accordingly).

When pneumatic tyres are fitted they must be inflated to the pressure specified by the industrial tractor manufacturer.

8.4. **Removable attachments**

8.4.1. Rated capacity of removable attachments if the maximum load in kilograms, permitted by its manufacturer, that the attachment is capable of handling in normal operation under specified conditions.

9. **GENERAL PROVISIONS**9.1. **Information plates**9.1.1. *Identification plates*

9.1.1.1. Every industrial truck must bear a durable identification plate in a prominent position giving the following information:

All engine-powered trucks	Battery electric-powered trucks
a) Name of the manufacturer (or the importer) of the truck	a) Name of the manufacturer (or the importer) of the truck
b) Type	b) Type
c) Production or serial No and year of manufacture	c) Production or serial No and year of manufacture
d) Unladen mass ⁽¹⁾ of the truck in working order without removable attachments, but with the fork-arms in the case of fork-lift trucks	d) Unladen mass ⁽¹⁾ of the truck in working order without battery and without removable attachments but with the fork-arms in the case of fork-lift trucks
	e) Authorized maximum and minimum battery mass
	f) Battery voltage

⁽¹⁾ The mass may vary by + 5 % from the figure shown on the plate.

9.1.1.2. Identification plates for removable attachments

Every removable attachment must carry a separate identification plate giving the following information:

- (a) name of attachment manufacturer (or importer);
- (b) type;
- (c) production or serial number and year of manufacture;
- (d) mass of attachment;
- (e) distance of the centre of gravity of the attachment from its mounting face on the truck;
- (f) rated load capacity;
- (g) in the case of hydraulically operated attachments the operating hydraulic pressure recommended by the attachment manufacturer;
- (h) Warning: 'The capacity of the truck and attachment combination must be complied with'.

9.1.1.3. Trucks operating in special conditions

If a truck is designed to operate in special conditions it must bear a durable plate in a prominent position, giving the following information:

- (a) designation of the special condition(s) of use;
- (b) capacity of the truck in each of the special conditions of use.

9.1.1.4. Traction batteries and containers

Each container must bear a durable identification plate in a prominent position giving the following information:

- (a) name of battery manufacturer;
- (b) type;
- (c) serial number;
- (d) nominal voltage;
- (e) capacity in ampere hours at the five-hour rate;
- (f) service mass (with ballast if used to compensate for lack of battery mass).

Furthermore, it must be possible to stamp the mass on the removable container near the lifting means.

9.1.2. *Capacity plates*

Every truck or tractor must have a durable capacity plate affixed in a prominent position, easily readable by the operator showing the data specified below.

This capacity plate may be combined with the identification plate if desired.

9.1.2.1. High-lift trucks

The capacity plate must show the data specified in Addendum B.

9.1.2.2. Fixed platform and low-lift trucks

The capacity plate must show the basic rated capacity in kilograms as defined in 8.2.1.

9.1.2.3. Industrial tractors

The capacity plate must show the draw-bar pull in newtons as defined in 8.3.1 and also the period of time during which this pull can be exerted.

9.1.3. *Other information*

It is not obligatory to put this information on a plate.

9.1.3.1. Devices for slinging of trucks

Locations for slinging must be clearly indicated on the truck (see 9.8.4).

9.1.3.2. Pneumatic tyre inflation pressures

The prescribed inflation pressures must be clearly indicated on the truck.

9.1.4. If such indications are in words, they must be written in the language(s) approved by the country where the truck is to be used.

9.2. Immobilization, prevention of unintentional movement and unauthorized use

9.2.1. A parking brake must be provided conforming to the requirements specified in 9.3.4.1 and 9.3.4.2 below.

The special requirements for order-picking trucks are covered in section 10.

9.2.2. The truck must be provided with a special device (e.g. a key) which prevents its use by any unauthorized person.

Switch keys for pedestrian-controlled trucks and for stand-on and sit-on trucks manufactured by the same manufacturer must not be interchangeable.

9.3. Brakes — Performance

9.3.1. Service brakes

Self-propelled industrial trucks must be fitted with brakes capable of:

- (a) holding the truck and its maximum permissible load on the maximum operational gradient specified by the manufacturer;
- (b) developing in either direction, on smooth, dry and clean concrete, a minimum draw-bar drag (F) which:
 - for all trucks (except tractors) is expressed as a percentage of the gross mass of the truck with its rated load,
 - for tractors is expressed as a percentage of the gross mass of the tractor, without trailers.

The minimum value of F is related in the following tables to the maximum speed attainable by the truck with its rated load or by the tractor without trailers (V_1 in km/h).

If a truck's actual braking capability is automatically related to speed, the minimum draw-bar drag, F, may be varied as speed is varied (see graph A).

The minimum value of F in the following tables must be attainable with the appropriate actuating force specified in 9.3.2.

Group	Types of truck	Value of F for speeds		
		up to 5 km/h	from 5 to 13,4 km/h	> 13,4 km/h
A ⁽¹⁾	All industrial trucks except groups B, C, D	9,3 %	1,86 V %	25 %
B	tractors with one or two braked wheels	13 %	2,6 V %	35 %
C	tractors with four braked wheels	18,6 %	3,72 V %	50 %

⁽¹⁾ Where the mast or fork-arms can be retracted, the values apply with the mast or fork-arms in the retracted position.

Group	Types of truck	Value of F for speeds		
		up to 4 km/h	4 to 9 km/h	> 9 km/h
D ⁽²⁾	Trucks with elevating operator and high-lift lateral (and front) stacking trucks	4 %	1 V %	9 %

⁽²⁾ For further details see 10.1 and 10.2

GRAPH A

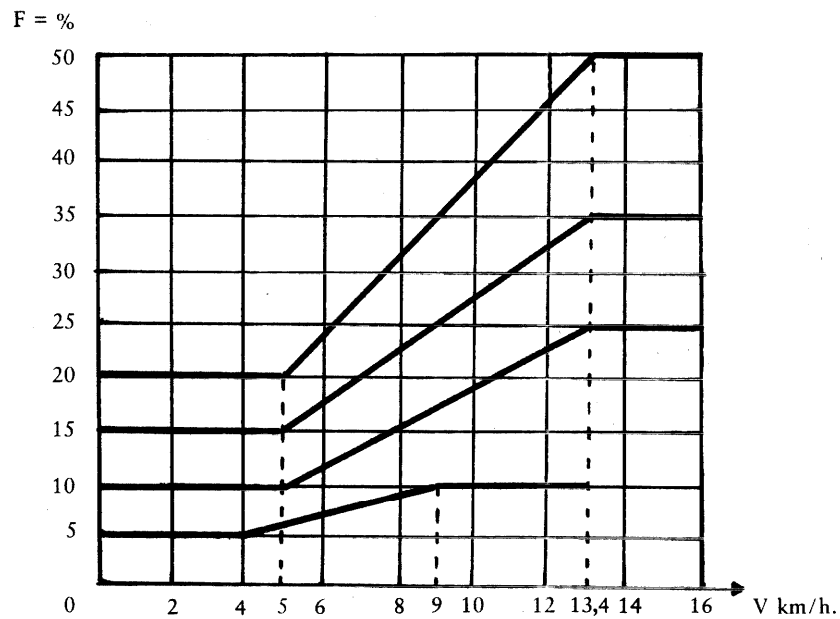

$$\begin{aligned}
 3,72 \cdot V &= 18,6 = C \\
 2,6 \cdot V &= 13 = B \\
 1,86 \cdot V &= 9,3 = A \\
 1 \cdot V &= 4 = D
 \end{aligned}$$

Irrespective of the gradient, the service brake must provide the minimum braking capability specified in graph A for speeds of up to 5 km/h for truck groups A, B and C and of up to 4 km/h for truck group D.

9.3.2. Service brake controls ⁽¹⁾

- Brakes applied by depressing the brake pedal must conform to the above draw-bar drag table with a maximum pedal force not exceeding 600 newtons.
- Brakes applied by releasing the brake pedal must conform to the above draw-bar drag table. The necessary force required to release the brakes and to keep them released while travelling must not exceed 300 newtons.
- Brakes applied by means of a hand lever must conform to the above draw-bar drag table, when a maximum force of 150 newtons is applied to the hand lever.
- Trucks with the operator standing and pedestrian-controlled trucks must have automatically applied brakes whose minimum draw-bar drag is to be selected in accordance with the above table.

⁽¹⁾ Order-picking trucks are covered in section 10.

9.3.3. Only friction brakes, hydrostatic transmissions and electrical braking systems are acceptable as service brakes.

9.3.4. *Parking brake*

9.3.4.1. Each industrial truck except an industrial tractor must be equipped with a parking brake which can at least hold the truck, with its maximum permissible load, without assistance from the driver, on the maximum gradient as specified by the manufacturers. The braking capacity must be accordant with a gradient no less than the values shown below:

- (a) Sit-on or stand-on trucks, electric or ICE except types b and c: 15 %;
- (b) Narrow-aisle trucks (reach trucks) straddle trucks, pallet stackers, high-lift platform trucks, or low-lift trucks: 10 %;
- (c) Trucks referred to in 1.4.1.6, 1.4.1.9, 1.4.1.10 and 1.4.3: 5 %;
- (d) Pedestrian-controlled trucks: 10 %.

9.3.4.2. Each industrial tractor must be equipped with a parking brake which holds the tractor itself, without trailers, and without assistance from the driver, on the maximum gradient that it is able to climb (without load) or on the following gradient, whichever is lower.

- sit-on or stand-on tractors, ICE or electric: 15 %;
- pedestrian-controlled tractors: 10 %.

9.3.4.3. Brake-operating systems

Service and parking brakes must be operated by means of independent systems, but may be effective on the same arresting equipment (e.g. brake shoes).

This does not apply to trucks which have the type of automatic service/parking brake specified in 9.3.2 (b) and (d).

9.4. **Wheels**

When split wheels are used with pneumatic tyres, the truck must be provided with devices to prevent the user from separating the halves of the wheel before removing the wheel from the axle.

9.5. **Controls**

9.5.1. *Direction-of-travel controls*

In accordance with ISO Standard 3691 (second edition — 1980 — 11 — 15), sections:

8.1 to 8.2.3.3

8.3.1 (a), (b), (c)

8.3.1.1 to 8.4.3.2

with the following requirements as regards 8.4.1.1:

- (i) The brake, accelerator and clutch pedals and the pedal or pedals for forward and reverse motion, if any, must be designed, built and set out in such a way that they may be operated without risk of confusion.
- (ii) The indication of the functions of the different pedals must be clearly shown in the driving instructions *and* in readable and indestructible location visible at all times to the driver in his normal driving position.
- (iii) The braking action should not be hindered by simultaneous use of other controls.
- (iv) The pedals must be:
 - such that the mechanical resistance is compatible with the forces to which the pedals are subject,
 - such that they are protected from the possible effects of involuntary manoeuvres.

- (v) Member States shall recognize as conforming to the above requirements trucks built in conformity with the harmonized standards elaborated by the CEN in compliance with the procedure laid down in Directive 83/189/EEC, references for which have been published in the *Official Journal of the European Communities*.
- 8.4.1.2.
Gear-change lever
As ISO 3691, 8.4.1.2.
- 8.4.1.3.
Direction-change lever
As ISO 3691, 8.4.1.3.
- 8.4.1.4
Safety control and brakes — Electric-powered sit-down-rider industrial trucks.
Delete ISO paragraph and replace under the above heading with:
Travel control must be so arranged that the truck will move only when the direction control is actuated and will not move at a speed greater than inching speed unless control has been actuated for both speed and direction. Where no neutral position is provided the truck must not move unless the speed control is activated.
- 8.4.1.5
Safety control and brakes — Internal-combustion-engine-powered sit-down-rider industrial trucks.
Delete ISO paragraph completely.
8.4.2 to 8.4.3.2 As ISO 3691 inclusive.
- 9.5.1.1. On electric trucks, a separate switch, independent of the control system, must automatically open the travel circuit when the operator leaves the truck.
- 9.5.1.2. Trucks with automatic transmission must be fitted with a device which must prevent the truck being started whilst the transmission is engaged.
- 9.5.2. *Load handling controls*
In accordance with ISO Standard 3691, section 8.5.
- 9.5.3. *Control symbols*
In accordance with ISO Standard 3287.
- 9.6. **Speed limitation ⁽¹⁾**
- 9.6.1. Pedestrian-controlled trucks must be so designed that they are not capable of speeds in excess of 6 km/h in the unladen condition when operating on level ground.
Single-speed pedestrian-controlled trucks must be so designed that they cannot reach a speed in excess of 4 km/h, empty and on level ground, or maximum acceleration of 0,5 m/s². Single-speed trucks must be low-lift only.
- 9.6.2. Stand-on trucks must be so designed that they are not capable of speeds in excess of 16 km/h in the laden condition when operating on level ground.
- 9.7 **Requirements for power systems and accessories**
- 9.7.1. *Exhaust and cooling systems*

⁽¹⁾ Order-picking trucks are covered in section 10.

- 9.7.1.1.1. The exhaust system must be designed and fitted with due consideration for the comfort and well-being of the operator. In particular, the exhaust pipe must have its exhaust port so arranged as to cause the minimum discomfort to personnel.
- 9.7.1.1.2. The air flow through the cooling system must be arranged in a manner to avoid discomfort to the operator.
- 9.7.1.2. Fuel tanks
- If a fuel tank is within or contiguous to the engine compartment and excessively high temperatures may occur, the tank and/or filling arrangement must be isolated from the electrical and exhaust systems by a suitable protection such as a separate enclosure or by baffles. The tank location and facilities for filling must be such that spillage or leakage will drain to the ground and not into the engine or operator's compartment or onto electrical or exhaust system parts.
- 9.7.1.2.1. Fuel spillage must not be possible under operating conditions. The fuel tank and fill fittings must be so located as to minimize the possibility of damage to the tank and its fittings.
- 9.7.1.2.2. The fuel tank must be removable. The fuel tank and fill fittings must be so located as to minimize the possibility of damage to the tank and its fittings.
- It is not necessary that tanks for liquid fuels other than liquefied petroleum gas (LPG) which are made of sheet steel of a thickness equal to or greater than five millimetres are removable, provided they have undergone treatment which protects them against atmospheric agents. The procedure for checking on tanks must be indicated in the use and maintenance instructions.
- 9.7.1.3. Fuel systems must be firmly secured to the truck and the fastenings arranged to minimize the effects of vibration. The tanks will be adequately protected against mechanical overload, e.g. by plate sheeting.
- 9.7.1.4. Tanks must be fitted on the truck in such a way that they are not unduly exposed to abrasion or shock nor to the corrosive action of the products handled by the truck.
- 9.7.2. *Additional requirements for internal combustion engine driven trucks, using liquefied petroleum gas*
- 9.7.2.1. Containers
- 9.7.2.1.1. The containers for liquefied petroleum gas may be either permanently fixed on the truck or quickly removable.
- 9.7.2.1.3. The containers must be firmly secured to the truck and the fastening must be unaffected by vibration.
- The pipe fittings and accessories on the container must be adequately protected against all mechanical overload, e.g. by plates or grids.
- 9.7.2.1.4. Containers, whether fixed or removable, must be equipped with a device to prevent the sudden emission of a large volume of gas or liquid, particularly in the case of a pipe failure. This does not apply to the pressure relief valves.
- The fuel take-off on the container must be equipped with an easily and quickly accessible manually operated valve. The position and method of operation of this valve must be clearly marked on the outside of the truck on or near the valve.
- The fuel take-off must be in a liquid form, unless the container and engine are specially equipped for direct vapour withdrawal.
- 9.7.2.1.5. All containers which require to be filled to a fixed maximum liquid level by the user must have the following fittings:

- (a) A suitable safety pressure relief valve connected to the vapour space of the container. Where such containers are fitted inside compartments of vehicles the discharge side of the relief valve must be piped to atmosphere.
The gas must be led away safely. See also 9.7.2.3.3;
- (b) A fixed maximum-level-indicating device. Where containers are fitted inside compartments of vehicles the discharge side of any maximum-level-indicating device which relies on bleeding gas to atmosphere must terminate at a readily visible position on the outside of the vehicle.
1. The maximum-level-indicating device which relies on bleeding to atmosphere must be designed so that the bleed hole is not larger than 1,5 millimetres in diameter and also that the parts of the device cannot be completely withdrawn in normal gauging operations.
 2. All maximum-liquid-level devices must be suitable for the LPG in use and indicate the maximum product level which must not exceed that permitted by Community regulations for pressure vessels in so far as they exist, or otherwise according to the provisions of the country in which they are used;
- (c) If a liquid-level gauge is fitted, it must not vent to atmosphere.
- 9.7.2.1.6. If containers are installed in a compartment, this compartment must have permanent openings at the very bottom. The total surface area of these ventilation openings must be at least 200 cm² allowing adequate ventilation to the outside atmosphere and without risk for the operator.
- 9.7.2.1.7. When containers are removable, their fastening must permit easy handling and easy checking of installation after the exchange of containers.
- 9.7.2.1.8. When installing removable containers which incorporate a safety relief valve they must be so located on the truck that the safety pressure-relief valve opening is always in communication with the vapour space (top) of the container. This may be accomplished by an indexing pin which positions the container when the container is properly installed.
- 9.7.2.1.9. If a spare or additional container is carried on the truck, it must be secured in an approved manner as laid down in 9.7.2.1.3 and 9.7.2.1.8.
- 9.7.2.1.10. The containers must be positioned in such a way that they are not exposed to the damaging effects of heat, particularly heat from the engine and the exhaust system. It must be possible to fit a heat-shield which must not inhibit ventilation under any circumstances.
- 9.7.2.2. LPG piping
- 9.7.2.2.1. Connecting piping and all associated parts must be easily accessible, protected against damage and wear, and be flexible enough to withstand vibration and deformation in service.
- (a) Pipe-work must be so arranged that damage or leaks are easily detectable.
- (b) It must be installed in such a way that it cannot be damaged by the hot parts of the engine.
Fully rigid pipes must not be used for connecting the container to equipment on the engine.
- (c) High pressure pipes (above 1 bar) must be supported at least every 500 millimetres (flexible) or 600 millimetres (rigid).
- 9.7.2.2.2. Hoses, piping and all connections operating at pressure above one bar must be suitable for a working pressure of 25 bars and must withstand without bursting a test pressure of 75 bars.
Hoses, piping and all connections operating below one bar must withstand without bursting a test pressure of five times the maximum pressure likely to be encountered in service.
- 9.7.2.2.3. The containers and their connections must be installed in such a way that there are no projections outside the overall contour of the truck. Container connections must be protected by a rigid guard.

- 9.7.2.2.4. Excessive pressure must be avoided in any section of pipe-work containing LPG between two shut-off valves which may be closed; a pressure-relief valve or other suitable means may be used if necessary.
- 9.7.2.2.5. The use of aluminium piping in the liquid petroleum gas lines is not permissible.
- 9.7.2.2.6. Hose lengths must be as short as possible.
- 9.7.2.2.7. High pressure unions and joints (above one bar) must be made of metal except for any constrained sealing washers.
- 9.7.2.3. Equipment
- 9.7.2.3.1. The supply of gas must be automatically cut off when the engine stops irrespective of whether or not the ignition system has been switched off.
- 9.7.2.3.2. For multi-fuel applications the system must be designed to avoid the possibility of LPG entering any other fuel container, and so that each fuel source is cut off before the alternative one is opened.
- 9.7.2.3.2.1. If the truck is equipped with two or more containers to supply fuel, they must be connected via a multiway valve, or other suitable means, so that LPG can be drawn only from one container at a time. The use of two or more containers (at the same time) must not be possible.
- 9.7.2.3.3. Safety pressure-relief valves or liquid level indicators must be installed in such a way that they cannot discharge on truck components which represent a source of ignition in the direction of the driver.
- 9.7.2.3.4. If corrosion of a part will interfere with its proper functioning it must be provided with a corrosion-resistant protective coating.
- 9.7.2.3.5. All fuel system components must be firmly secured to the truck and the fastenings arranged to minimize the effect of vibration.
- 9.7.2.3.6. Reducing valves must be readily accessible for inspection and maintenance.
- 9.7.3. *Electric trucks*
- 9.7.3.1. Battery
- 9.7.3.1.1. Metal covers must be designed to provide an air space of at least 30 millimetres above the live parts of the battery. Alternatively the covers or live parts of the battery must be insulated when an air space of at least 10 millimetres must be provided above the live parts of the battery. The insulation must be firmly attached to avoid their disintegration or displacement in normal use.
- 9.7.3.1.2. The cover(s) must be so constructed that in normal use no force is transmitted to or contact made with the battery (including its cells or connectors) when a force of 980 newtons is applied to the cover(s) over any area 300 × 300 millimetres square. The cover(s) must be fitted in such a way as to avoid displacement in normal use.
- 9.7.3.1.3. Suitable ventilation holes must be provided in the battery container, compartment or cover so that dangerous accumulations of gases do not occur when the equipment is used in accordance with manufacturer's instructions.
- 9.7.3.1.4. Batteries and containers of all trucks must be constrained to prevent displacement during normal operations which gives rise to danger. On rider trucks means must be provided so that in the event of 90° overturning the battery assembly will be constrained, so as to avoid the risk of injury to the operator which could otherwise occur by the battery being displaced.

- 9.7.3.1.5. No sparking components or component which can reach a temperature of 300 °C or more may be located where potentially explosive gas/air mixtures can be formed.
- 9.7.3.1.6. Voltage
The nominal battery voltage may not exceed 96 volts.
- 9.7.3.1.7. Voltage limits
Electrical equipment must be so designed that all functions operate and safety is not jeopardized if the battery voltage should fall below the nominal voltage (see Note) by as much as 30 %, i.e. to $0,70 \times$ nominal voltage.
- NOTE:
Definition — Nominal voltage = maximum number of cells which are connected in series multiplied by the nominal voltage of each cell, e.g. 2,0 volts for conventional lead acid cells, 1,2 volts for conventional alkaline cells.
- 9.7.3.2. Connectors
The connectors used for connecting the traction batteries to the equipment of electrically operated industrial trucks and to the charging equipment must comply with the requirements of Addendum C.
- 9.7.3.3. It must not be possible to energize the truck movement circuits whilst external charging leads are connected.
- 9.7.3.4. Resistors
All resistors must be located and arranged so as to avoid overheating and damage to adjacent parts of the truck.
- 9.7.3.5. Protection
- 9.7.3.5.1. In the normal operating condition of the truck the uninsulated live parts must be protected to prevent direct contact.
- 9.7.3.5.2. There must be no electrical connection to the truck frame, with the permissible exception of:
(a) frame fault detection system;
(b) lighting and ancillary equipment, providing its operating voltage does not exceed 24 volts and it is electrically isolated from the main power source;
(c) earthing during charging when using on-board chargers.
- 9.7.3.5.3. Motor circuits must be protected against short circuit conditions.
Auxiliary circuits must be protected against short circuit conditions and dangerous excess currents. Several auxiliary circuits in parallel, with combined current not exceeding 10 amps, may be protected by a single device.
- 9.7.3.5.4. The electric circuits must be so designed, and if necessary protected, that two or more frame faults cannot cause uncontrolled operation.
- 9.7.3.5.5. Pulse switching systems must be arranged so as to avoid uncontrolled movements; any uncontrolled power-on condition due to a fault in the electronic circuit must be terminated immediately. Means must be provided for checking the operation of this safety circuit or system.
- 9.7.3.6. Conductors
All conductors must be either effectively insulated and where necessary protected or must be so placed and safeguarded as to avoid danger when the truck is in its normal operating condition.
The cross-sectional area of conductors must be so selected that during operation of the truck the temperature does not exceed that specified for the class of insulation used.

The following provisions apply to copper conductors external to enclosures (excluding short leads between electric or electronic components which are placed close to each other):

- (a) all conductors must be flexible;
- (b) the cross-sectional area of conductors of adequately supported copper cables and wiring harnesses must not be less than 0,5 square millimetres;
- (c) single copper conductors must have a cross-sectional area of not less than 1,0 square millimetre.

9.7.3.7. Emergency isolation

An emergency isolating control or controls must be provided which must be readily accessible to the operator at all times whilst in any of the operating positions recommended by the manufacturer. The isolating device must be capable of isolating without danger at least one pole of the main supply lines and must be capable of interrupting the normal maximum current (including motor starting current) by one of the following methods:

- (a) connector specified in 9.7.3.2;
- (b) manual isolator;
- (c) emergency switch connected into the coil circuit of two separate contactors.

9.7.3.8. Electro-mechanical brakes

Where electro-mechanical brakes are fitted these must be mechanically applied and electrically released.

9.7.3.9. Dielectric test

For ex works, new, dry vehicles and with disconnected traction battery, an alternating test voltage between 25 and 100 hertz must be used for testing between live parts and the frame.

Semiconductors or similar electronic components liable to become damaged by application of the test voltage may be bypassed or removed.

The equipment must be capable of surviving an alternating test voltage as follows:

Nominal voltage	Alternating test voltage	Testing time
≤ 48 V	500 V	} 1 minute
> 48 V	1 000 V	

If there should be need for a second test, the alternating test voltage must be reduced to 80 % of the test voltage specified in the table above.

If a dielectric strength test with a testing time of one second is carried out as an alternative, the alternating test voltage must be increased to 1,1 times the above values. If direct voltage with a testing time of one second is used as the test voltage, the test must be carried out using the above alternating test voltage multiplied by 1,6.

9.7.3.10. Insulation resistance test

The insulation in industrial trucks must possess adequate electrical resistance.

As a routine test the industrial truck and traction battery must be checked separately. The test voltage must be greater than the nominal voltage and less than 500 volts.

The insulation resistance between live parts and frame of all electric components of the industrial truck with the exception of the battery is deemed adequate if it amounts to at least 1 000 ohms multiplied by the nominal voltage of the battery.

The insulation resistance of the traction battery in a charged state with the presence of electrolyte is deemed adequate if it is at least 1 000 ohms between the live parts and the frame of the powered truck.

9.7.3.11. Safety devices for electrical and electronic circuits

The electrical and electronic circuits of safety devices mentioned in the following sections:

- 9.7.3.7 (b) and (c) Emergency isolators;
- 9.10.5 Protection of operator, pedestrian-controlled trucks;

10.1.1.1	}	Reduction of speed and braking;
10.1.2.1		
10.1.2.3		
10.1.3.1		
10.1.3.2		
10.1.2.2		Speed limitation and prevention of travel;
10.2.5.3.4		Slack wire-ropes or slack chains;
10.2.5.8		A second limiting device at the top of travel

must be so designed and fitted that in the event of faults the safety function is preserved.

Mechanically operated switches must be so constructed that they automatically isolate the circuit, their operation being affected through a minimum of intermediary devices.

Note:

Where it is not possible to satisfy the above requirements by a simple electrical or electronic circuit, the electrical or electronic circuits may be duplicated in order to check their correct functioning. A fault must cause the motion to stop and re-starting must not be possible until the circuit has been restored.

9.8. **Systems and components for lifting, tilting and other movements**

9.8.1. *Lifting and tilting mechanism* ⁽¹⁾

9.8.1.1. Mast mechanism chains

Only leaf and roller mechanical chains are authorized. When the lifting mechanism includes a chain or chains, the truck manufacturer must select chains which, in relation to the minimum breaking load certified by the manufacturer of the chain, will provide a factor K ⁽²⁾ of at least 5/1 in relation to the static load that would exist in a single chain or equally loaded chains when the maximum rated load is in the transporting position, assuming no friction in the mast structure. Pulley or sprocket wheel diameters must be at least three times the pitch of the chains.

9.8.1.2. Wire-ropes

When the lift mechanism includes one or more wire-ropes the truck manufacturer must select wire-ropes which, in relation to the minimum breaking load certified by the manufacturer of the wire-rope, will provide a factor K ⁽²⁾ of at least 6/1 in relation to the static load that would exist in a single wire-rope or equally loaded wire-ropes when the maximum rated load is in the transporting position, assuming no friction in the mast structure. The minimum diameter of the wire-rope guide pulleys, measured from the bottom of the groove, must be equal to 22 times the diameter of the wire-rope.

9.8.1.3. Hydraulic lifting system

The descent of the rated load caused by a leakage in the hydraulic system must not exceed 100 millimetres during the first 10 minutes, with the oil in the hydraulic system at normal working temperature. The leakages referred to are those occurring under normal conditions of use of the trucks; external leakages resulting from abnormal conditions of use or faulty construction are not taken into consideration.

9.8.1.4. Limitation of stroke of lifting system

The lift assembly must be fitted with stops to prevent over-travel. In addition, means must be provided to prevent the fork carrier and moving elements of the mast structure accidentally disengaging from the upper end of the mast. All movements with a limited travel must be provided with stops to prevent over-travel.

⁽¹⁾ Order-picking trucks are covered in section 10.

⁽²⁾ $K = \frac{\text{minimum breaking load when new per chain or cable} \times \text{number of chains or cables}}{\text{carrying capacity of the truck} + \text{dead weight of lifting mechanism}}$

9.8.1.5. Lowering speed limitation

A control device must be incorporated in the lift circuit which even in the event of a failure of the hydraulic circuit, excluding the hydraulic lift cylinder, must restrict the rate of descent speed of the lifting mechanism with its rated load. In no case must the speed exceed 0,6 m/s.

9.8.1.6. Hydraulic tilting systems

The leakage rate of the complete hydraulic tilting system (cylinder, distributor, etc.) must allow only an average pivoting speed of the mast to the front of less than five degrees in the first 10 minutes, from the vertical mast position when the truck is raising its rated load at a height of 2,50 metres or, in the case of trucks of less than 2,50 metres, at their maximum height.

The average pivoting speed allowed by leakages must not exceed half a degree in one minute for trucks with a maximum tilt of less than five degrees.

9.8.1.7. Strength of the truck-structure and the attachments

The structure of a truck and its attachments must be of adequate strength and capable of bearing the loads $1,33 Q_1$ and $1,33 Q_2$ at the relevant maximum heights for a period of 15 minutes.

Q_1 = the maximum load at the standard load centre distance and standard lift height (rated capacity, Addendum A, points 2, 3, 4).

Q_2 = the maximum load at maximum lift height, in accordance with the instructions on the capacity plate (actual capacity, Addendum A, point 5).

If a truck is subjected to testing, the loads may be placed on the forks at their corresponding maximum height by means independent of the truck under test. The truck should be placed on a substantially horizontal surface. The mast should be in a substantially vertical position.

The vertical position of the mast may be adjusted during the test.

For safety reasons, the truck must be fastened in such a way that the test is not influenced. The tyres may be removed.

No permanent deformation or defect must be present at the end of the test.

9.8.2. *Hydraulic systems*

9.8.2.1. Hydraulic circuits

Hoses, piping and all connections must be capable of withstanding without bursting a pressure of at least equal to three times the rated operating pressure of the hydraulic circuit to which they might actually be subjected.

9.8.2.2. Pressure-relief valves

All hydraulic systems must include a reliable device which prevents the pressure in the system from exceeding a preset safe level (pressure-relief valve).

The device must be so designed and fitted that accidental loosening or adjustment is avoided and that a tool or key is required to alter the pressure setting.

9.8.2.3. In the case of a fault or an interruption of the supply of energy, the design of the hydraulic installation must be such that the hydraulic pressure in the system does not accidentally cause the pump to function as an hydraulic motor.

9.8.2.4. The hydraulic system must be designed and installed in such a way that its performance and reliability are not reduced or its components damaged as a result of external stresses, vibration or movements of the truck or components thereof, etc.

9.8.2.5. The hydraulic system must be so designed that the oil in circulation is continuously and automatically filtered.

9.8.3. *Fork-arms and carrier*

9.8.3.1. Fork-arms — Technical characteristics and testing in accordance with ISO International Standard 2330, 1st version 1978, notwithstanding that reference is made therein to hook-on type arms only.

9.8.3.2. Fork-arms — lateral locations

Means must be incorporated in the fork-arm and carrier to prevent unintentional lateral displacement. Stops must be provided to prevent lateral disengagement at the extremities.

9.8.3.3. Fork extensions

Fork extensions must be designed to prevent accidental disengagement from the fork-arm.

9.8.3.4. If a fork arm removal slot is provided at the bottom of the carrier, it should not be positioned opposite a slot at the top of a carrier unless means are provided to prevent the fork-arm being inadvertently displaced.

9.8.4. Slings devices

Where fitted, slinging devices must be so designed as to avoid any accidental risk of unhooking.

9.9. Operator's position

9.9.1. Dimensions

The operator's seat or standing position shall be so constructed that while operating the truck the operator shall have room to withdraw within the plan outline of the truck.

The dimensions shall not be less than the following dimensions (in millimetres):

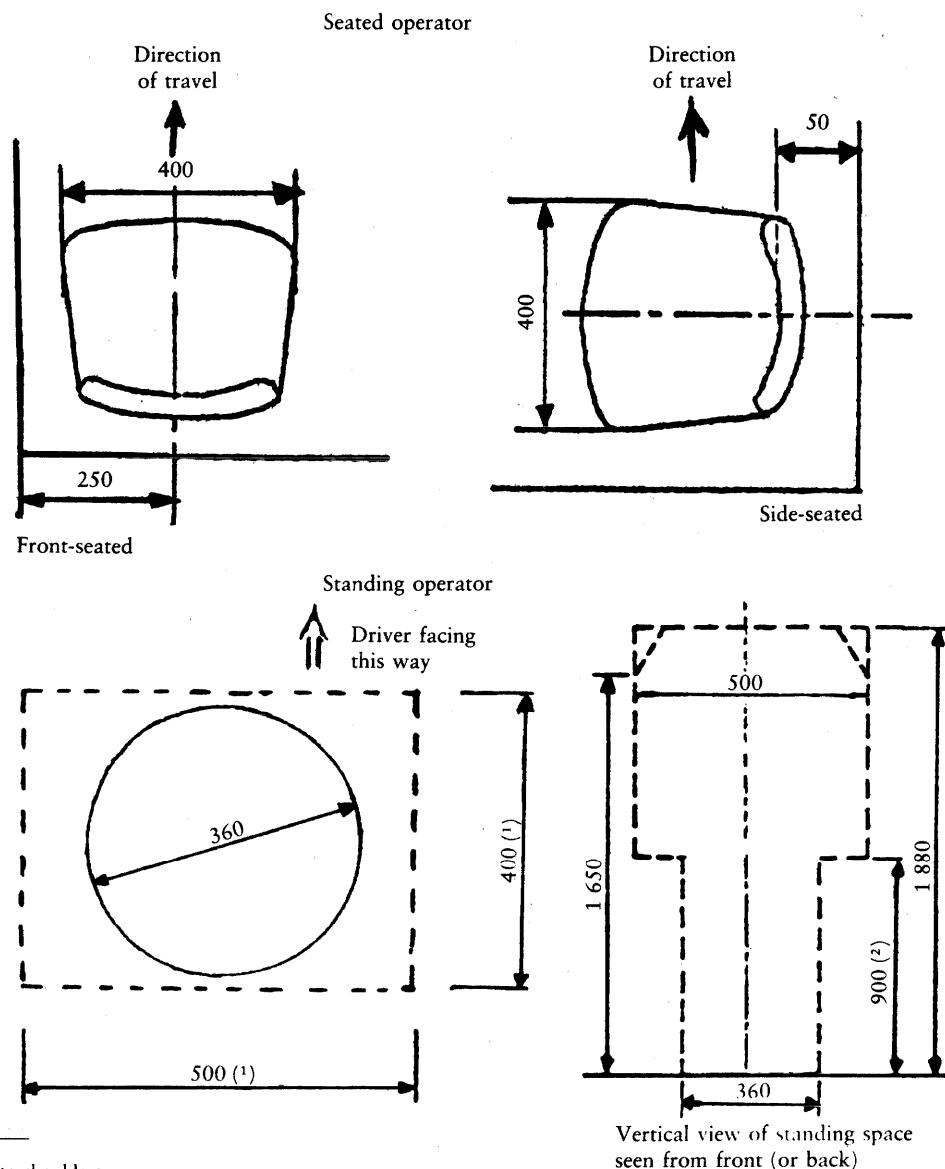

(¹) From hip to shoulders.
 (²) The hip height is, exceptionally, to maximum dimension.

The floor space which must be provided for the lower part of the operator's body (feet to hips) must not be less than 1 400 cm² and must also be capable of housing a circle of 360 millimetres in diameter.

9.9.2. *Access*

Rider trucks must be designed to permit easy access and egress without undue risk of slipping or falling. The surface of the floor must be slip resistant. An adequate number of steps or running boards fitted with slip-resistant surface or coverings must be provided.

No step or running board must in any case have a height above that next below it or above the ground exceeding 500 millimetres. Safety handles must be provided as necessary.

9.9.3. The operator's seat must be upholstered and may be resiliently suspended to minimize the transmission of vibration to the operator's person.

9.9.4. *Temperature*

The operator's seat and all parts of the truck within reach of the operator when in his normal operating position or when getting into or leaving his operating place must be insulated against excessive temperature arising from the engine or other equipment.

9.10. **Protective devices**

9.10.1. *Operator's overhead guard*

Every industrial rider truck with a lift exceeding 1,80 metres must be fitted with an overhead guard to protect the operator.

This may be removable.

Should the lifting height of pedestrian-controlled trucks or pedestrian trucks with provision for the operator to ride exceed 1,80 metres it must be possible to fit the load-lifting device of the truck with a load backrest extension.

For industrial trucks with elevating operator position, see section 10.

Overhead guards must conform to the following requirements:

9.10.1.1. Design features

9.10.1.1.1. General

The overhead guard must extend over the operator under all normal circumstances of truck operation.

Where the overhead guard is fixed to the mast, this requirement applies whatever the position of the mast.

The control levers, in their neutral position, the unprotected pedals and the steering wheel may project in the direction of the mast up to a maximum distance of 150 millimetres beyond the vertical projection of the outline of the overhead guard on to a horizontal plane. No account is taken of the handbrake in its 'off' position.

Protection of the operator's legs and feet is regarded as satisfactory if the distance, vertically projected on to a horizontal plane, between the front of the overhead guard and the rear of the forward structure of the truck chassis providing the protection does not exceed 150 millimetres.

9.10.1.1.2. Failure of the tilting mechanism must not, directly or indirectly, cause the operator to be in danger because of the overhead guard.

9.10.1.2. Dimensions

9.10.1.2.1. The overhead guard should be designed and constructed in a manner that reduces visibility as little as possible.

9.10.1.2.2. Openings on the top of the overhead guard must not exceed 150 millimetres in one of the two dimensions, width or length.

The overhead guard must be constructed in such a manner that it can be provided with an additional fitting making it possible in special cases to increase the protection of the operator against falling objects.

9.10.1.2.3. For rider seated trucks, a vertical clearance of at least 1 000 millimetres must be provided from the point of maximum depression of the seat under the operator, to the underside of the guard in the vicinity of the operator's head when he is in his normal operating position.

9.10.1.2.4. For rider standing trucks, a vertical clearance of at least 1 880 millimetres must be provided from the platform on which the operator stands to the underside of the overhead guard in the vicinity of the operator's head when he is in his normal operating position.

9.10.1.2.5. The operator's overhead guard must hinder the operator as little as possible while he is mounting or dismounting the truck.

9.10.1.3. Testing of overhead guards

9.10.1.3.1. General

To test protection of the operator from falling objects (but not the impact of a falling capacity load) the following tests must be carried out on a prototype guard fitted to a truck of the type for which it has been designed.

The mounting of the guard on a test chassis is also admissible provided that the mounting is the same as that on the truck for which it is designed.

9.10.1.3.2. Static test

The overhead guard must be able to support for 1 minute a static rigid test load, uniformly distributed on the area of the upper part of the main frame, according to the following table and graph:

Rated capacity of truck in kg (Q)	Static test load in kg
Up to 2 000	$2 \times Q$ maximum 4 000 kg
from 2 000 to 5 000	$2\,000 + Q$ maximum 7 000 kg
from 5 000 to 10 000	$4\,500 + \frac{Q}{2}$ maximum 9 500 kg

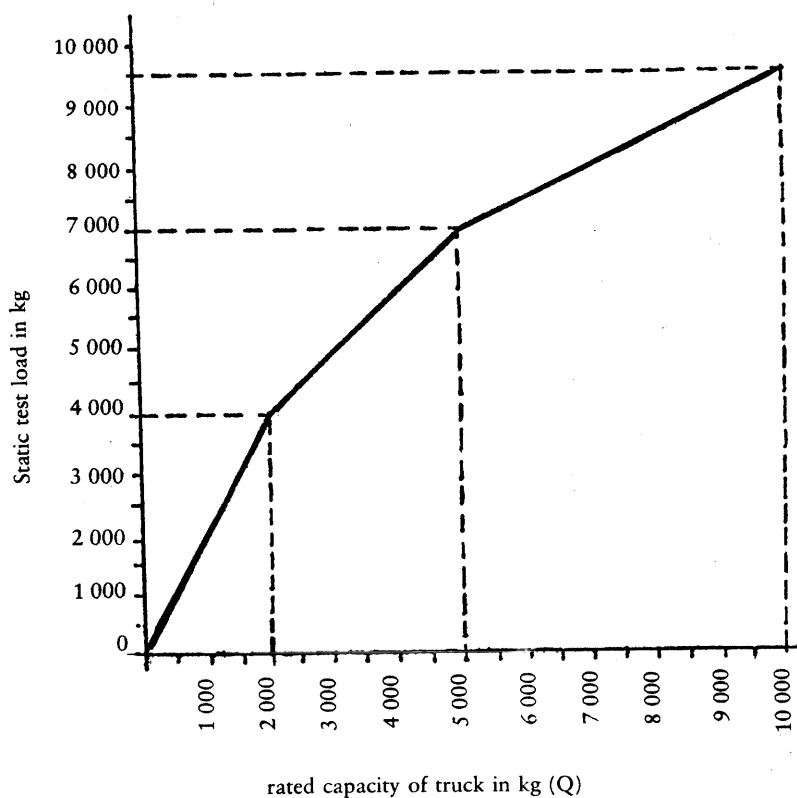

9.10.1.3.3. Dynamic test

The overhead guard must be able to withstand the impact of a hardwood cube, weighing not less than 45 kilograms.

The test cube is positioned to drop in free fall with a flat surface approximately parallel to the top of the overhead guard, and not strike with a corner or edge. The cube is dropped a distance of 1,5 metres 10 times, so that it strikes the guard at random points within a 600-millimetre-diameter circle, whose centre is vertically above the centre point of the operator's seat or position.

9.10.1.3.4. Test results; static and dynamic

After both tests the guard must not show fracture, parts separation or permanent vertical deformation exceeding 20 millimetres measured on the underside of the guard within a 600-millimetre-diameter circle, whose centre is vertically above the centre point of the operator's seat or position.

9.10.1.3.5. Auxiliary fixtures

During the dynamic tests, deformations that might occur on auxiliary fixtures such as wire mesh, cloth, toughened glass, etc. are ignored.

9.10.2. *Load backrest extension*

High-lift trucks must be designed so that they may be equipped with a load backrest extension.

9.10.3. *Platform*

9.10.3.1. Operator's stand-on platforms on end-controlled trucks must extend beyond the operator's position and be so designed that they could withstand a compression force corresponding to the mass of the laden truck and applied along the longitudinal axis of the truck with the outermost projection of the platform against a flat vertical surface.

Note:

For the purpose of this section, the operator's platform includes any surrounding reinforcement or parts of the truck which provide resistance to crushing of the platform.

9.10.3.2. Operator's stand-on platforms which overhang the truck must be provided with guards at the side or front of the platform.

9.10.3.3. Operator's stand-on platforms which are fitted to pedestrian-controlled trucks but placed outside the area defined by the axles or truck-frame, must fold or pivot automatically when the operator leaves the platforms and must be equipped with means to prevent the unintentional folding or pivoting of this platform when the operator is standing thereon.

9.10.3.4. Operator's fixed stand-on platforms which are at heights greater than 1 200 millimetres above the floor must be equipped with rails or other equally effective means of protection, comprising top rails, intermediate rails and toe boards to a height not less than 1 000 millimetres or more than 1 100 millimetres measured from the upper surface of the top rail to the platform, the toe boards having a minimum height of 100 millimetres. The rails should be capable of withstanding a force of 900 newtons applied in any horizontal direction ⁽¹⁾.

Removable or hinged rails must be constructed in such a manner that proper rail positioning is easily accomplished and a secured position is visibly discernible.

When hinged rails are provided they must open only upwards, inwards or sideways.

⁽¹⁾ Chains and ropes are not considered as equally effective means of protection.

- 9.10.4. *Wheel guards*
- 9.10.4.1. Trucks with wheels which extend beyond the confines of the truck chassis must be provided with devices which ensure the protection of the driver when he is in the normal operating position against objects thrown up by the wheels (e.g. mud, gravel, stones, bolts, etc.).
- In the case of the steered wheels, the protective device must cover the wheels only when the truck is moving in a straight line.
- 9.10.5. *Protection of operator — pedestrian-controlled trucks*
- The tiller of pedestrian-controlled trucks must incorporate a device to reverse the direction of travel or stop the truck should the tiller in its operating position come into contact with a solid body (e.g. the operator's person).
- 9.10.6. *Warning devices*
- All trucks must be equipped with a clearly audible warning device.
- 9.10.7. *Crushing, shearing and trapping points*
- Relative moving parts which are within the operator's reach in his normal operating position must either be adequately guarded or be separated by the minimum distances specified hereunder:
- Places where the operator's fingers can be trapped: 25 mm;
- Places where the operator's hands or feet can be trapped: 50 mm;
- Places where the operator's arms or legs can be trapped: 100 mm.
- 9.11. **Visibility**
- Operators of trucks must have sufficient visibility to enable them to effect all manoeuvres in safety.
- 9.12. **Environmental conditions**
- 9.12.1. *Noise*
- The noise emission of a truck is to be measured in accordance with the following specifications:
- 9.12.1.1. Environmental noise
- The maximum admissible noise level in the environment is 90 dB(A).
- 9.12.1.2. Noise at operator station
- The maximum admissible equivalent noise level (L_{eq}) at the operator's station is 90 dB(A).
- 9.12.2. *Operator's cab*
- 9.12.2.1. If a cab is fitted in lieu of an overhead guard it must comply with the requirements of 9.10.1.
- 9.12.2.2. If a totally enclosed cab is fitted with a heater, the heater's air intake must be connected to a fresh air inlet; partial recycling of the air is, however, permissible. The heater must be securely fixed; it must be possible for the hot air to be circulated adequately in the cab and a device must be fitted to prevent the operator from burning himself.
- 9.12.2.3. Provision must be made for efficient ventilation of the cab.
- 9.12.2.4. If glass is used in the window apertures it must be of the safety glass type. The windscreen and rear window must be fitted with sufficiently large wipers.
- 9.12.2.5. (Deleted.)

- 9.13. **Load-gripping attachments**
- 9.13.1. Attachments (e.g. clamps, side-shifters, etc.) must be designed and manufactured in such a way that unintentional detachment and lateral displacement are prevented.
- Movements of the attachment and its parts must be mechanically limited at the extreme positions.
- 9.13.2. Clamping devices must be so designed that the clamping pressure is automatically sustained by means of stop valves or any other effective system when the truck's control mechanisms are in the neutral position.
- In the event of malfunctions in the power supply system of an attachment, it must not be possible for the load to fall off or unintentionally shift.
- 9.13.3. If an attachment has its own separate hydraulic system, this must comply with the provisions of section 9.8.2 (Hydraulic systems).
- 9.13.4. If an attachment has a hydraulic system which is connected to the truck hydraulic system then the two systems must be compatible and the combined system must comply with the provisions of section 9.8.2 (Hydraulic systems).
- 9.13.5. Attachments must be so designed and fitted to the truck that the operator, in his place, can see the roadway and the load lifting member.
- 9.13.6. Crushing, sheering and trapping of attachments other than those which grip the load must conform to the requirements laid down in 9.10.7.
- 9.13.7. The combined load moment of an attachment and its load must not exceed the rated load moment of the truck to which it is fitted.
- The stability of a lift truck/attachment combination together with the load must be verified by the truck manufacturer or according to his instructions.
- When determining the residual lifting capacity of a truck/attachment combination, account must also be taken of the impact that occurs when running up against the limit stops (e.g. with a side-shifter) under the nominal load.
- 9.14. **Steering shock restriction**
- The transmission of shocks to the steering control of sit-on and stand-on trucks shall be limited as far as is reasonably practicable to avoid injury to the operator's hand or arm.
- 9.15. **Lights**
- Sit-on and stand-on trucks shall be so designed that it is possible for the manufacturer or his agent or any other qualified person referring to the manufacturer's instructions to equip them with an electrical circuit whereby headlamps, red rear lamps and, if necessary, a direction-indicating device can be connected.
- 9.16. **Truck stability**
- The stability of the truck must be guaranteed in all operating positions and during all lifting and travelling movements when it is being used for the purpose for which it was intended. This requirement may be regarded as having been fulfilled when the provisions of the Annexes concerning the relevant tests are complied with.
10. **ADDITIONAL REQUIREMENTS FOR TRUCKS WITH ELEVATING OPERATOR POSITION AND TRUCKS SPECIFICALLY DESIGNED TO TRAVEL WITH ELEVATED LOADS**
- The following types of industrial trucks are excluded from Section 10:
- (a) trucks without lift (non-elevating operator platform and load carrier);
 - (b) low-lift order-picking trucks, where the load is elevated just sufficiently to facilitate transportation;
 - (c) order-picking trucks where the operator's platform can only be elevated up to and including 1,20 metres.

- 10.1. **General requirements**
- Trucks must be so designed that when operating under their special conditions their stability enables them to travel in complete safety whilst the lift mechanism or load orientating mechanisms and/or operator are being elevated, lowered or orientated.
- The manufacturer may decide to limit the performance of the truck if the necessary automatic devices are available.
- 10.1.1. *Safety arrangements for certain operations*
- 10.1.1.1. Trucks free-ranging outside the stacking aisles or in aisles without guidance systems, with elevated load and/or elevated operator must:
- (a) be automatically prevented from travelling above 4 km/h when the operator position or the lifting mechanism is elevated more than 500 millimetres above its lowest position (see Fig. 1);
 - (b) be automatically prevented from travelling above 4 km/h when the operator position or lifting mechanism is elevated above 500 millimetres and not more than 2 500 millimetres above the lowest position, and restricted to creep speed (not more than 2,5 km/h) at these elevations when the steering is turned more than 10° from a straight ahead position (see Fig. 1);
 - (c) have traction automatically prevented or restricted creep speed (not more than 2,5 km/h) when the driving position or the lifting mechanism is elevated more than 2 500 millimetres above its lowest position (see Fig. 1);
 - (d) at lift heights exceeding 2 500 millimetres, except at creep speed, have traction automatically prevented when the load elevating mechanism is being operated.
- 10.1.1.2. Aisles with a guidance system must have a device which, when the truck is in operation, limits the degree of deviation between the longitudinal axis of the truck and the longitudinal axis of the aisle to approximately 2°.
- 10.1.1.3. When trucks operating in the aisles are wholly or partly prevented from overturning by means of external supports (e.g. by truck rollers running in restraining rails fitted to the racking), the special stability tests for operation in the aisles should only be carried out in the directions in which the truck is not protected against overturning.
- Disengagement from these supports must be prevented while the truck is operating in an elevated position.
- 10.1.1.4. When a truck is operating in the aisles in accordance with paragraphs 10.1.1.2 and 10.1.1.3, a designed safety width of at least 100 millimetres must be observed between the outermost point of the operator's platform and the racking or the load in its normally stacked position.
- 10.1.2. *Control safety arrangements*
- 10.1.2.1. Where truck stability depends on reduction of speed and/or braking at a certain lift height (or heights), operation beyond those limits must be automatically prevented.
- Where, above certain lift heights, the truck is only permitted to travel at creep speed (not more than 2,5 km/h), operation above this speed must be automatically prevented.
- When a truck is designed to carry out three-way stacking it must have a device which automatically prevents:
- (a) travelling at more than 2,5 km/h when the load is in the forward position;
 - (b) horizontal displacements of the load when the appliance is travelling.
- This requirement does not apply when the manufacturer guarantees the stability of the truck by some other means.
- 10.1.2.2. When any part of a truck mechanism is able to intrude laterally into the racking space, a device or devices must be provided that prevent such movements whilst the truck is travelling, lifting or

lowering, and similarly prevent travelling except at creep speed (not more than 2,5 km/h), when the mechanism is extended or extending.

10.1.2.3. At lift heights where truck travel is restricted to creep speed (not more than 2,5 km/h), acceleration must be automatically reduced to a rate not more than the maximum deceleration permitted by the manufacturer for that elevation.

10.1.2.4. All controls and their mechanisms and systems which initiate movements must be biased to the safe position (movements stopped) and be equipped with a fail-safe mechanism. Where such an arrangement is not reasonably practicable, a warning system shall be fitted to indicate failure.

10.1.3. Service brakes

10.1.3.1. For operations without guidance systems inside or outside the stacking aisles with the operator position or lifting mechanism not more than 500 millimetres above its lowest position, the brake draw-bar drag must comply with the requirements of 9.3.1, group A, or alternatively the travel speed must be automatically reduced to not more than 9 km/h (see Fig. 1).

10.1.3.2. When the operator position or the lifting mechanism is positioned more than 500 millimetres above its lowest position both when the truck is with aisles with guidance systems and when it is free ranging, provided the braking capability is automatically related to speed, the brake draw-bar drag, F, in 9.3.1 may vary simultaneously with the speed in accordance with the formulae.

10.2. Additional requirements for trucks with elevating operator position

10.2.1. *Speed*

Trucks with elevating operator position must be so designed as not to exceed a laden and bearing traction speed of 16 km/h (see Fig. 1).

10.2.2. *Traction brakes*

10.2.2.1. Service brakes and parking brakes may be operated by a common system. Where this arrangement is used, failure of the system must result in application of the brakes.

10.2.2.2. Service brakes and parking brakes may employ common mechanical arresting equipment, e. g. brake shoes, cams and cam levers.

10.2.2.3. Brake actuation must be by a control normally biased to the 'brake-on' position. Removal of the operating force must automatically apply the brakes to give a draw-bar drag consistent with stability (see 9.3.1, group D).

When trucks are operated in the free ranging mode at speeds above 9 km/h (see 10.1.3.1) where increased braking to 9.3.1 group A is required, the extra braking may be conventionally applied and need not be biased to the 'brake-on' position.

The extra brake must by design be incapable of being actuated until the load and/or the operating position are at a height of less than 500 millimetres.

10.2.2.4. Brakes may be power assisted, but it must be possible to obtain the minimum braking specified in 9.3.4.1 (c) in the absence of the brake power assistance source.

10.2.3. *Operator position*

10.2.3.1. The operator's position on trucks designed to operate above 1,2 metres must be provided with guard rails in accordance with the requirements laid down in 9.10.3.4.

- 10.2.3.2. Gates, doors, etc. must be capable of opening only inwards, upwards and sideways, and should preferably be self-closing. When the truck is designed to elevate the operator's position above 1,2 metres, the gates, doors, etc. must have a mechanism that prevents traction and elevation movements when the gates, doors, etc. are not properly in place.
- 10.2.3.3. In 'walk-on' type trucks with elevating operator position where a pallet, etc., may be used as a walking surface, means must be provided to prevent any risk of falling, in the case of the operator or his assistant, if a pallet is overturned or shifted. In addition 'walk-on' type order-picking trucks elevating above 1,2 metres from the ground must be provided with means to prevent the operator or his assistant falling from the platform when the pallet is not in place.
- 10.2.3.4. For 'walk-on' type trucks with elevating operator position (10.2.3.3) where the operator position may be raised to heights of more than 1,2 metres, the guard rails specified in 10.2.3.1 must be extended to encompass the whole of the area accessible to the operator (and assistant if permitted by the design).
- 10.2.3.5. A handrail is sufficient at the entrance of the load elevation. Where the enclosure of the operator position is such that an operator could become trapped, either the doors must be designed to facilitate release from the outside or an alternative means of egress/access, such as a roof trap door, must be provided.
- 10.2.3.6. The floor of the operator position must be approximately horizontal, slip resistant and, if primarily for outside use, designed to prevent the accumulation of water.
- It must be capable of withstanding a pressure of 1 500 N/m² and a mass of 100 kilograms distributed over an area of 0,16 m² at any part of its surface.
- Where the floor is provided with glazing, it must be of equivalent strength to the floor or be protected to a standard at least equivalent to the floor.
- Where grated flooring is used, the holes or openings must not allow a 20 millimetre diameter sphere to pass through. The section of each opening must in no case exceed 400 mm².
- 10.2.3.7. The materials used in the construction of the operator position must, at least, not be easily flammable.
- 10.2.3.8. Where the sides of the operator's platform are fitted with glazing, the protection specified in 10.2.3.1 must be extended across the glazing as appropriate.
- 10.2.4. *Overhead guard*
- An overhead guard meeting the requirements of 9.10.1 must be fitted above the operating position.
- Alternatively, the requirement contained in 9.10.1.3.2 may be waived if an elevating arresting device is fitted in such a way that in all cases it protects the operator from the effects of contact between the roof of the operator's platform and any obstruction. On hydraulic lifting mechanisms the pressure limiter may be used for this purpose if the overhead guard is of an adequate strength.
- 10.2.5. *Safety devices and constructional details*
- 10.2.5.1 A device or devices must be fitted, or the controls so arranged, to ensure that the operator (and his assistant — see subsection 2) are safely within the confines of the operating position before any movements of the truck or platform can be initiated by the operator, and also to ensure that he/they cannot reasonably extend beyond the confines of the operating position without cancelling truck movements.
- Where a truck with an elevating operator position is fitted with multiple manning security devices, a lock-out master switch must be fitted to permit variations of the manning team. The switch must be lockable by a key different from any other used on the truck.

10.2.5.2. Safety of lifting equipment

10.2.5.2.1. The truck shall be so equipped as to prevent the operating position plummeting in the event of a failure of the lifting system.

10.2.5.2.2. The requirements of 10.2.5.2.1 are considered to be fulfilled if the following precautions are taken:

10.2.5.2.2.1. For fully mechanical lifting equipment

- a device is provided which will support the operating position with its maximum load specified by the manufacturer in the event of a failure of the lifting system, and
- the ropes/chains employed in the operator elevating system at least conform to 10.2.5.3.1 to 10.2.5.3.5 inclusive.

However, until 31 December 1992 Member States will be free to allow in their territory also the marketing of trucks with elevating operator position which meet only one of the above two specific conditions.

It must not be possible for the operator to disengage this mechanism unless the rate of descent is limited to 0,4 m/s.

10.2.5.2.2.2. For fully hydraulic lifting equipment.

A device must be provided which prevents descent in the event of a pipe fracturing or a hose bursting. This device must be either directly attached to or incorporated in the lift cylinder. It must not be possible for the operator to disengage this mechanism unless the rate of descent is limited to 0,4 m/s.

10.2.5.2.2.3. For combined lifting systems.

Any combined lifting system must employ those safety mechanisms listed in 10.2.5.2.2.1 and 10.2.5.2.2.2.

10.2.5.3. Ropes/chains employed in operator elevating systems.

10.2.5.3.1. Where ropes or chains are used for elevating/supporting the operating position at least two identical ropes/chains are to be employed. The load must be uniformly distributed between the chains or wire ropes. It must be possible to inspect the chains or wire-ropes over their entire length.

10.2.5.3.2. The aggregate breaking load of the set of chains or wire-ropes, as certified by the chain or wire-rope manufacturer, are for chains at least 10 times and for wire-ropes at least 12 times the static operating load supported by all the chains or wire-ropes together ⁽¹⁾, it being understood that, for each chain or wire-rope, K factors of at least 5/1 and 6/1 respectively, as stipulated in 9.8.1.1 and 9.8.1.2, must be provided.

10.2.5.3.3. The strength of every rope/chain termination must be at least 80 % of that of the rope or chain.

10.2.5.3.4. Where the operator elevating mechanism employs wire-ropes or chains, one or more slack wire-rope or chain detection devices must be fitted. Such detection must automatically suspend the downward motion of the elevating mechanism of the operating position.

A device may ensure that:

- the load-lifting device or operating position can be freed,
- the load-lifting device can be raised,
- the operating position or the load-lifting device can be lowered to the lowest position,
- the operating position or load-lifting device cannot be further raised until the fault has been rectified and the detecting device is once more operational.

⁽¹⁾ See 9.8.1.1 and 9.8.1.2 for pulley or sprocket wheel diameters.

The elevating mechanism must be arranged to prevent wire-ropes becoming entangled, twisted and displaced from their normal operating position.

- 10.2.5.3.5. All effective steps must be taken to ensure that in the event of breakage of one or more chains or wire-ropes the arrangement of the chain(s) or wire-rope(s) and their anchorages remaining in use is maintained without bringing about any deformation of the basic components of the truck. The breakage of one chain or wire-rope must cause stopping of the raising or lowering movement which is taking place.
- 10.2.5.4. Where two control positions are embodied, one on the elevating section and one on the fixed section, it will be necessary to prevent actuation of the fixed section controls before and when the elevating section controls are operative. However, the emergency lowering requirements specified in point 10.2.5.7 are still applicable.
- The fixed section control position must be located clear of the area occupied by the elevating section control position when lowered.
- 10.2.5.5. The energy source (normally the battery) must be capable of being reliably disconnected from the truck traction, lifting and load manoeuvring systems by a means within easy reach of the operator regardless of the position of the operating cab/cage/head.
- The system must be so designed that no danger will result from interruption of the power supply during descent.
- 10.2.5.6. Trucks that are designed to elevate the operator position above 2,5 metres must be provided with means by which the operator can reach the ground safely in the event of the operator position becoming fixed in the elevated position.
- 10.2.5.7. Trucks designed to elevate the operator position above 2,5 metres must be fitted with an emergency lowering control, operable from ground level even in the absence of any energy source. The control position must be carefully selected so as to avoid any risk to the person who is operating from this position.
- 10.2.5.8. The lifting mechanisms must be provided with travel limiting devices. One of these devices must be an obligatory mechanical stop which prevents the lifting mechanisms becoming disengaged at the top of its travel.
- Means must also be provided to prevent the operator's position being accidentally disengaged from the lifting mechanism over the complete range of its movements.
- 10.2.5.9. Trucks with an operator position designed to elevate above 2,5 metres must be fitted with a flashing warning light visible from ground level when the truck is lowering and travelling.
- 10.2.5.10. Trucks equipped with pneumatic tyres must be fitted with a device or devices that minimize inclination and prevent loss of stability in the case of tyre failure.
- 10.2.6. *Information plates*
- 10.2.6.1. The capacity plate (9.1.2) must clearly indicate not only the capacity/height relationships but also heights at which brake draw-bar drag changes are automatically imposed.
- The capacity plate must be permanently fixed and be clearly readable by the operator in his driving position.
- 10.2.6.2. In addition to the labelling requirements in 9.1 and elsewhere, the truck must be fitted with a permanently fixed label clearly indicating the number of persons permitted on the operator's platform, while the truck is in use.

FIGURE 1

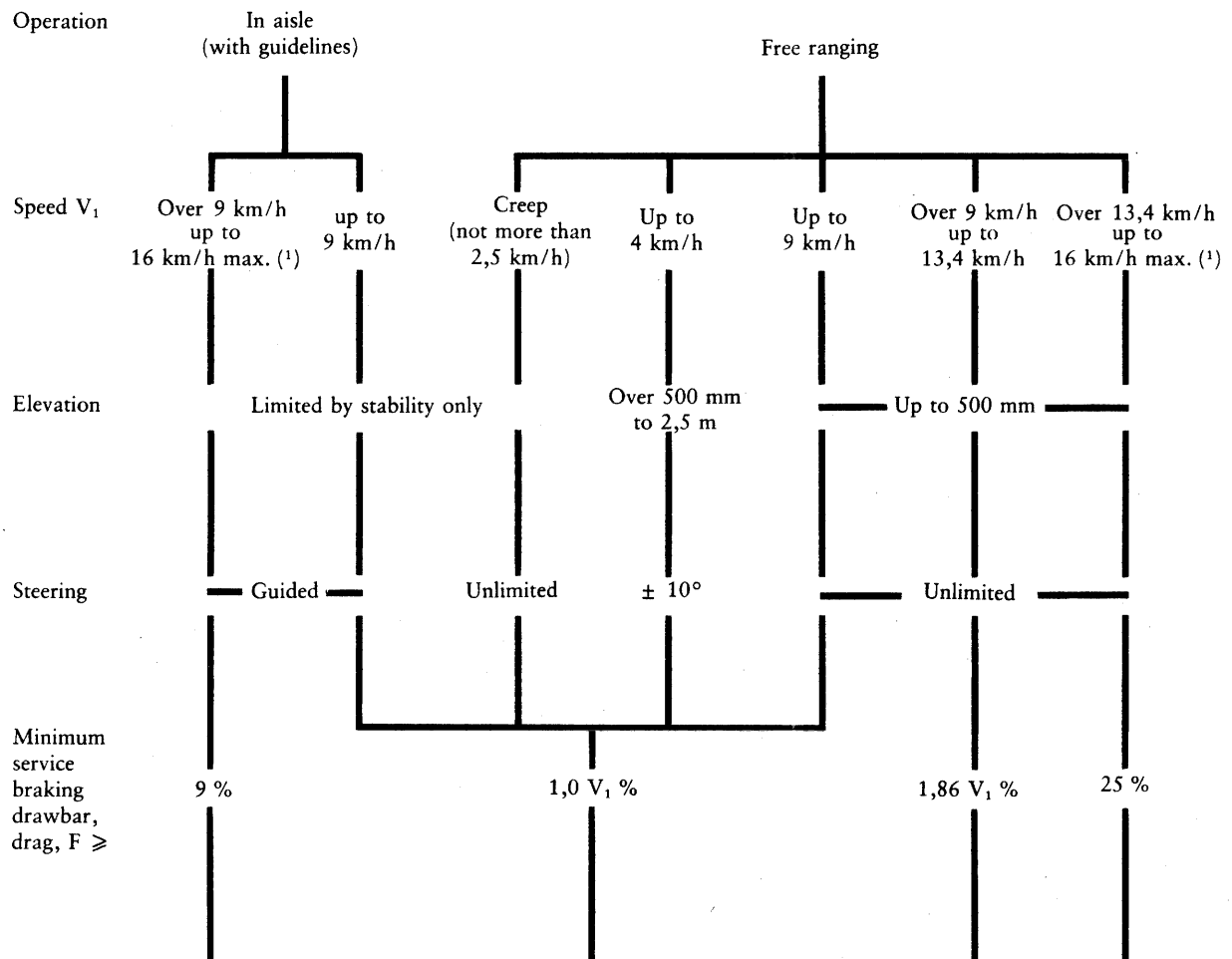

11. DOCUMENTATION — OPERATING AND SERVICING INSTRUCTIONS

Each self-propelled industrial truck (or by agreement of the user, each group of trucks) must be accompanied by a book (or books) detailing full operating and servicing instructions in a language understood by the user in the country in question.

Member States may require trucks to bear information regarding their national labour laws before being put into service on their territory.

⁽¹⁾ For non-elevating seated operator the 16 km/h maximum speed does not apply.

ADDENDUM A

DEFINITION OF CAPACITY

1. INTRODUCTION

This addendum defines 'rated capacity' which facilitates the comparison of manufacturer's basic models. This rated capacity is related to a standardized lift height.

It also defines 'actual capacity' which relates to the rating of a truck when fitted with its operational mast. This actual capacity is derived from the relevant standard stability tests.

2. RATED CAPACITY

The manufacturer's rated capacity of a truck shall correspond to the maximum load Q ⁽¹⁾ which it is designed to carry and stack, on fork arms or platform, with a vertical double mast, the maximum lift height of which is equal to the standard lift height 'H', as specified in point 3, and with a standard load centre distance 'D', as specified in point 4, measured horizontally and vertically between the centre of gravity 'G' of the load and:

- (a) the front face of the fork shank;
- (b) the upper face of the fork blade (see Figure 1);

or equivalent dimensions in the case of trucks fitted with a platform.

Even if the truck does not utilize a double mast or does not lift to the standard lift height 'H' it shall still be given a rated capacity as if the mast were available.

FIGURE 1

- D = standard load centre distance
- G = load centre of gravity, positioned in the longitudinal plane of symmetry between the mast uprights
- H = standard lift height
- Q = load

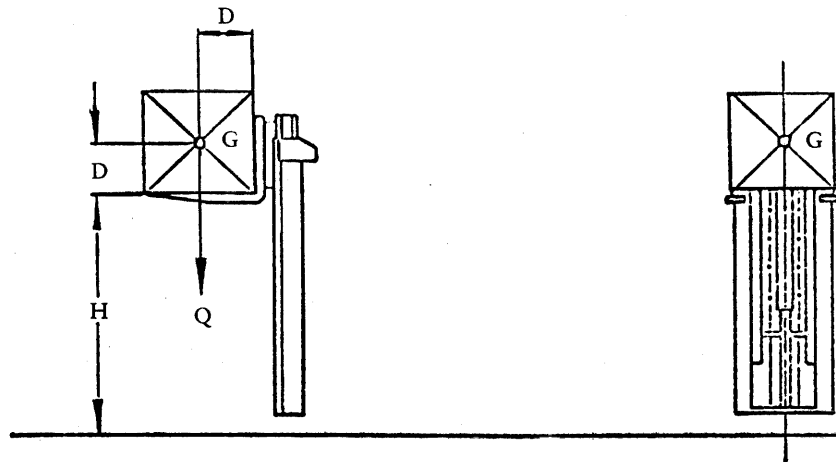

3. STANDARDIZED LIFT HEIGHTS

The standardized lift height is fixed as follows:

H = 2,5 metres for pallet stackers and high-lift platform trucks having a width across fork arms or platform up to and including 690 mm.

H = 3,3 metres for all other types of truck.

⁽¹⁾ When a truck embodies facilities for an elevated operator an allowance of 90 kilograms shall be included in addition to the rated load 'Q'.

4. STANDARDIZED LOAD CENTRE DISTANCE

- 4.1. For series-produced counter-balanced trucks up to a capacity of 10 000 kilograms delivered to countries using the international unit system (SI), the standardized load centre distances used for rating shall be the following:

Load Q	Standardized distances 'D'
Up to 999,9 kg	400 mm
From 1 000 kg up to 4 999,9 kg	500 mm
From 5 000 kg up to 10 000 kg	600 mm

- For all other trucks except side-loading fork-lift trucks, the standard load centre distance used for rating shall be 600 millimetres.
- Side-loading fork-lift trucks shall be rated at a load centre distance specified by the manufacturer.
- It is permissible to rate trucks for special applications with load centre distances related to the application.

5. ACTUAL CAPACITY

The actual capacity of a truck is derived from the appropriate stability tests and will vary with the different types and heights of mast fitted, and the different load centre distances (see point 4) used in rating. The rating shall be determined with standard fork arms or platform. Additional actual capacity ratings with removable attachments may also be established where permitted by the appropriate stability specification.

ADDENDUM B

CAPACITY PLATE DATA

1. INTRODUCTION

This addendum is to facilitate the uniform provision of information on capacity plates.

The derivation of the capacity data is covered in Addendum A.

2. RATED CAPACITY

The rated capacity may be shown on the identification plate e.g. 'Rated capacity = 6 000 kg'.

The rated capacity may be shown on the capacity plate but in such a way that it is not confused with the actual capacity entries, e.g. 'Model No XYZ/6.0'.

3. ACTUAL CAPACITY

The actual capacities, lift heights and load centre distances to be shown on the capacity plate shall comply with the following requirements:

- 3.1. The actual capacity at the truck maximum lift height and the standardized load centre distance shall always be shown.

Actual capacities of one or more other load centre distances shall also be shown if the truck design permits ⁽¹⁾.

- 3.2. When it is permissible to lift actual capacities greater than those in 3.1 to truck lift heights less than the maximum, these shall be shown at the associated lift heights and standardized load centre distance.

Actual capacities at one or more other load centre distances shall also be shown if the truck design permits ⁽¹⁾.

- 3.3. Other actual capacities and load centre distances may also be shown.

4. ATTACHMENTS

When a truck is fitted with one or more removable load-handling attachments as original equipment, the truck must carry capacity information additional to that required in 3. The actual capacities, lift heights and load centre distances with each attachment fitted must be shown as follows:

The capacities authorized at the corresponding lift heights and the respective load centre distances must always be shown. Also, the attachment to which the ratings apply should be clearly identified.

⁽¹⁾ The additional load centre distance(s) shall preferably be standardized load centre distances and for trucks delivered in countries using SI units, one of these distances, if not already included, shall be 600 millimetres.

5. UNITS

The units used to express the ratings must be:

SI

- lift height: millimetres (mm)
- load: kilograms (kg)
- load centre distance: millimetres (mm)

6. MARKING

The details entered on the capacity plate may be in the form of a table or diagram.

ADDENDUM C

SPECIFICATION OF CONNECTORS

1. SPECIFICATION
 - 1.1. **Number of models**

This specification applies to three models, defined by their nominal current in amperes: 80 — 160 — 320 amperes.
 - 1.2. **Definitions**
 - 1.2.1. *Nominal current*

The nominal current is the current in amperes that the connector is able to carry continuously without exceeding the allowable temperature rise indicated in 1.3.8.
 - 1.2.2. *Emergency breaking current*

The breaking current under maximum load is the current specified in 2.3.2 that the connector must be able to break in the case of exceptional circumstances or hazard.
 - 1.2.3. *Voltages*
 - 1.2.3.1. **Maximum voltage**

The connectors must be capable of being operated up to a maximum voltage of 150 volts, direct current; the maximum voltage must be marked on the outside of the connector (see 1.3.11).
 - 1.2.3.2. **Operating voltages**

The nominal battery voltage must not exceed 96 volts.
 - 1.3. **Manufacturing details**

Each connector comprises two connectable halves. Each half must be capable of being fitted with a mounting bracket.

 - 1.3.1. *Casings*

The casings must be of adequate mechanical strength, not easily flammable, non-absorbant and resistant to acid, battery gas and dilute bases (e.g. salt). They should be able to be coloured in all the normal colours.
 - 1.3.2. *Contacts*

Each half-connector comprises two main contacts. Provision may also be made for two auxiliary contacts. All these contacts must be adequately protected against corrosion.

On all three models of connector the auxiliary contacts, if fitted, must be able to carry a current of 20 amperes. They must not make contact until after connection of the main contacts.
 - 1.3.3. *Mechanical parts*

Mechanical parts must be adequately protected against corrosion.
 - 1.3.4. *Non-reversibility*

The casings must have incorporated a non-removable device ensuring the non-reversibility of the two half-connectors so as to prevent any reversal of polarity.

1.3.5. *Insulation*

Contacts and other current-carrying parts when connected or separated must not come into contact with metallic parts of the connector casing.

The insulation should be capable of withstanding temperatures from + 90 to - 20 °C.

Note:

Considering that the maximum temperature should not exceed 90 °C, the internal and external insulating materials can be chosen from class I or higher, of recommendation No 85 of the International Electrotechnical Commission (1957).

1.3.6. *Degrees of protection*

1.3.6.1. When the two half-connectors are coupled their enclosure must provide a degree of protection conforming to CENELEC HD 365 IP 23.

1.3.6.2. The half-connector connected permanently to the battery must be protected against the accidental contact of persons with live parts and against the introduction of middle-sized foreign bodies.

Note:

These various protections must conform to CENELEC HD 365 IP 23, namely:

IP 2* — Protection against the contact of fingers with live parts. Protection against the penetration of middle-sized foreign bodies;

IP 3* — Water falling in rain at an angle equal to or smaller than 60° (about one radian) with respect to the vertical must have no harmful effect.

1.3.7. *Coding*

Each connector must be fitted with a coding device preventing the connection of a male half-connector with a female half-connector meant to operate on another voltage.

1.3.8. *Temperature limits*

The contacts, cable connecting parts and mechanical parts must be capable of withstanding a maximum temperature of 90 °C and a minimum temperature of - 20 °C.

1.3.9. *Half-connector terminals*

The two half-connectors must be connected to the battery and to the truck equipment (or to charging circuits) by cables.

The following table indicates, for the three models of connectors, the nominal section of copper cables.

Nominal current in amperes:	80	160	320
Nominal cable section in mm ² :	16	35	95

1.3.10. *Locking — Manoeuvrability*

Any two half-connectors when joined must be capable of being secured together by a locking device. This device must be capable of being unlocked quickly in case of emergency.

The two half-connectors must be able to be separated easily in any position. The maximum force required to separate the two connectors must not exceed 150 newtons. The locking device may be dispensed with if a minimum force of 15 newtons is necessary to separate the two half-connectors.

1.3.11. *Marking*

All connectors must bear legibly and indelibly the following marks:

- manufacturer's name or trade mark,
- maximum operating voltage: i.e. 150 V,
- nominal current in amperes (e.g. 160 A),
- the signs '+' and '-' corresponding to the contacts to be connected with the positive and negative poles of the battery.

2. TESTING PROCEDURES

All the following tests must be carried out on three prototypes of all the models of connectors. Mass-produced connectors must meet these requirements. This must be ensured by appropriate quality controls. The tests must be carried out in proper conditions to ensure safety.

2.1. Temperature rise test on connector current carrying components

To test the current-carrying components and thus take account of self-heating due to contact resistance, the connector is connected by means of cables of the nominal section as in 1.3.9. Cables are connected by one of the methods recommended by the connector manufacturer.

They must have a length of not less than two metres. Testing is carried out with the nominal current and at an ambient temperature of 20 ± 2 °C.

Testing is continued until temperatures are stable.

Rises in temperature are measured with thermocouples or by other methods of equivalent precision. The use of ordinary thermometers is prohibited.

The temperature rise must not exceed 65 °C.

2.2. Life test

The half-connectors being normally coupled, without current, are separated, then coupled again.

This test is repeated 5 000 times. After this test, the connector must be able to pass the temperature tests described in 2.1.

2.3. Test of disconnection under load

2.3.1. *Test of disconnection in overload conditions*

An assembly of two coupled half-connectors is connected to a source of direct current of 96 volts through a circuit having an inductance of $0,50 \pm 0,05$ millihenrys.

The connector carries the following currents:

- model 80 amperes: 200 amperes,
- model 160 amperes: 400 amperes,
- model 320 amperes: 800 amperes.

After the two connecting parts have been properly connected, the current is broken by separating the two parts at a speed of 0,8 to 1,0 m/sec.

This test is carried out five times consecutively.

After this test, the connector is inspected for damages, then coupled again and submitted to the temperature test as in 2.1.

Failing to be able to couple or to pass the temperature test shall result in rejection.

2.3.2. *Disconnection under emergency conditions*

Where emergency isolation is by method (a) in 9.7.3.7 the following test is carried out:

An assembly of two coupled half-connectors is connected to a source of direct current through an inductive circuit having an impedance such that the time constant of the circuit is 15 milliseconds and the current to be broken is four times the nominal current, when connected to a supply voltage of 96 volts.

The connector must be capable of clearing any arcs which are drawn as a result of this emergency disconnection. It is not imperative that the two halves of the connector remain serviceable after this test.

2.4. Immersion tests

The coupled half-connectors, without cables, are immersed for one hour in a solution of sulphuric acid having a specific gravity of $1,10 \pm 0,05$ at ambient temperature. After rinsing in clear water and drying the two half-connectors should be able to mate correctly and to pass the temperature test as in 2.1.

This test is repeated under the same conditions, using a solution of potassium hydroxide (caustic potash) of specific gravity $1,10 \pm 0,05$

The half-connectors are then tested in accordance with 2.5 and 2.6. They should previously have been immersed in hydrogen for at least 48 hours.

All the following tests are to be carried out on all three types in the order stated.

2.5. Dielectric test

Each half-connector without cables must be able to withstand for one minute a sine-wave alternating current, with a frequency between 25 and 100 hertz and voltage of 2 000 volts rms applied:

- between the two main contacts,
- between the auxiliary contacts, if any, and the main contacts,
- between all contacts connected together and the metallic parts of the connectors and the metallic parts fitted on the casing (if this casing is made of insulating material).

2.6. Drop test

A half-connector is connected to two lengths of 1 500 millimetres of cable of the maximum allowable section, the ends of which are located at 1 000 millimetres above the ground.

The half-connector is dropped from a height of 2 000 millimetres on to a concrete floor.

This test is carried out 25 times.

After these tests, no part of the connector must show any cracks or permanent deformation.

The half-connector must be able to mate correctly with another one.

ANNEX II

MANUFACTURER'S (OR IMPORTER'S) CERTIFICATE OF CONFORMITY IN RESPECT OF SELF-PROPELLED INDUSTRIAL TRUCKS

I, the undersigned
(Surname and first name, position, undertaking)

.....
.....

hereby certify that the self-propelled industrial truck specified hereunder conforms in all respects to the requirements of the separate Directive
(Title and number of Directive)

.....
.....

1. Category:

2. Manufacturer or his authorized representative in Community:

.....

3. Type:

4. Type number/serial number of self-propelled industrial truck:

5. Year of manufacture:

6. Any additional information:

.....

.....

.....

.....

Date: (Signature)

(Signature)

.....

(Position)

ANNEX III

CONFORMITY MARK

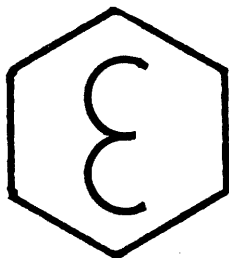

1. The conformity mark must be clearly visible and indelible. It must be affixed directly beside or on the descriptive plate.
 2. The dimensions of the mark must be so selected that the information on the mark is clearly legible and visible. The actual diameter of the circle described about the mark shall be at least 15 millimetres.
-