

II

(Acts whose publication is not obligatory)

COMMISSION

COMMISSION DIRECTIVE

of 18 April 1979

adapting to technical progress Council Directive 74/483/EEC on the approximation of the laws of the Member States relating to the external projections of motor vehicles

(79/488/EEC)

THE COMMISSION OF THE EUROPEAN COMMUNITIES,

Having regard to the Treaty establishing the European Economic Community,

Having regard to Council Directive 70/156/EEC of 6 February 1970 on the approximation of the laws of the Member States relating to the type-approval of motor vehicles and their trailers ⁽¹⁾, as last amended by Directive 78/547/EEC ⁽²⁾, and in particular Articles 11, 12 and 13 thereof,

Having regard to Council Directive 74/483/EEC of 17 September 1974 on the approximation of the laws of the Member States relating to the external projections of motor vehicles ⁽³⁾,

Whereas, in view of experience gained and of the state of the art, it is now possible to make requirements more stringent and to match them more closely to actual test conditions ;

Whereas luggage racks, ski racks and radio receiving or transmitting aerials are already marketed both separately and after being fitted to a vehicle; whereas if

it is possible to check them before they are fitted to a vehicle their free movement may be facilitated by the introduction of EEC type-approval for such systems considered as separate technical units within the meaning of Article 9a of Directive 70/156/EEC;

Whereas the provisions of this Directive are in accordance with the opinion of the Committee on the Adaptation to Technical Progress of the Directives Aimed at the Removal of Technical Barriers to Trade in the Motor Vehicle Sector,

HAS ADOPTED THIS DIRECTIVE:

Article 1

Directive 74/483/EEC is amended as follows:

- Articles 2, 3 and 4 are replaced by the following:

'Article 2

No Member State may, on grounds relating to external projections, refuse to grant EEC type-approval or national type-approval for a motor vehicle, or for luggage racks, ski racks or radio receiving or transmitting aerials considered as separate technical units, if:

- the vehicle complies with the provisions of Annexes I and II as regards external projections,

⁽¹⁾ OJ No L 42, 23. 2. 1970, p. 1.

⁽²⁾ OJ No L 168, 26. 6. 1978, p. 39.

⁽³⁾ OJ No L 266, 2. 10. 1974, p. 4.

- the luggage racks, ski racks or radio receiving or transmitting aerials considered as separate technical units within the meaning of Article 9a of Directive 70/156/EEC comply with the provisions of Annex I.

Article 3

1. No Member State may, on grounds relating to external projections, refuse to register or prohibit the sale, entry into service or use of any vehicle provided that the external projections comply with the provisions of Annexes I and II.
2. No Member State may, on grounds relating to external projections, prohibit the placing on the market of any luggage rack, ski rack or radio receiving or transmitting aerial considered as separate technical units within the meaning of Article 9a of Directive 70/156/EEC if it conforms to a type for which type-approval has been granted within the meaning of Article 2.

Article 4

A Member State which has granted type-approval shall take the measures necessary to ensure that it is informed of any modification to a part or characteristic referred to in item 2.2 of Annex I. The competent authorities of that Member State shall determine whether fresh tests should be carried out on the modified type and a fresh report drawn up. Where such tests reveal that the requirements of this Directive have not been complied with, the modification shall not be authorized.'

2. Annexes I, II and III to Directive 74/483/EEC are hereby amended in accordance with the Annex to this Directive.

Article 2

1. As from 1 January 1980, Member States shall not, on grounds relating to external projections :
 - refuse, in respect of a type of motor vehicle, to grant EEC type-approval, or to issue the copy of the certificate provided for in the last indent of Article 10 (1) of Directive 70/156/EEC, or to grant national type-approval, or
 - refuse to grant EEC type-approval for luggage racks, ski racks or radio receiving or transmitting

aerials considered as separate technical units within the meaning of Article 9a of Directive 70/156/EEC, or

- prohibit the entry into service of vehicles,

where the external projections of such type of vehicle or of such vehicles or of the aforementioned separate technical units comply with the provisions of Directive 74/483/EEC, as last amended by this Directive.

2. As from 1 October 1981 Member States :

- shall no longer issue the copy of the certificate provided for in the last indent of Article 10 (1) of Directive 70/156/EEC in respect of a type of vehicle if its external projections do not comply with the provisions of Directive 74/483/EEC, as last amended by this Directive,

- may refuse national type-approval of a type of motor vehicle if its external projections do not comply with the provisions of Directive 74/483/EEC, as last amended by this Directive.

3. As from 1 October 1983, Member States may prohibit the entry into service of any vehicle if its external projections do not comply with the provisions of Directive 74/483/EEC, as last amended by this Directive.

4. Before 1 January 1980, Member States shall bring into force the provisions necessary in order to comply with this Directive, and shall forthwith inform the Commission thereof.

Article 3

This Directive is addressed to the Member States.

Done at Brussels, 18 April 1979.

For the Commission

Étienne DAVIGNON

Member of the Commission

ANNEX

Amendments to the Annexes to Directive 74/483/EEC

ANNEX I:

GENERAL DEFINITIONS, APPLICATIONS FOR EEC TYPE-APPROVAL, EEC TYPE-APPROVAL, GENERAL SPECIFICATIONS, PARTICULAR SPECIFICATIONS, CONFORMITY OF PRODUCTION

Item 1.1 is to be re-worded as follows:

'1.1. The provisions of this Annex do not apply to exterior rear-view mirrors or to the ball of towing devices.'

Item 1.2 add the following sentence:

'This is valid both when the vehicle is stationary and in motion.'

Item 2.3 is to be re-worded as follows:

'2.3. "external surface" means the outside of the vehicle including the bonnet, the lid of the luggage compartment, the doors, the wings, the roof, the lighting and light-signalling devices and the visible strengthening components;'

Item 2.4 is to be re-worded as follows:

'2.4. "floor line" means the line determined as follows:

successively position round a laden vehicle a cone with a vertical axis the height of which is not defined, and with a half angle of 30° in such a way that it contacts, constantly and as low as possible, the external surface of the vehicle. The floor line is the geometric trace of these points of contact. In determining the floor line, the jacking points, exhaust pipes or wheels shall not be taken into consideration. The gaps of the wheel arches are assumed to be filled in by an imaginary surface forming a smooth continuation of the surrounding external surface. At both ends of the vehicle the bumper shall be taken into consideration when establishing the floor line. Dependent upon the particular vehicle the floor line trace may occur at the bumper section extremity or at the body panel below the bumper. Where two or more points of contact occur simultaneously, the lower point of contact shall be used to determine the floor line;'

Item 2.5 is to be re-worded as follows:

'2.5. "radius of curvature" means the radius of the arc of a circle which comes closest to the rounded form of the component under consideration;'

After item 2.5 the following new items 2.6, 2.7, 2.8 and 2.9 shall be added:

'2.6. "Laden vehicle" means the vehicle laden to the maximum permitted technical mass. Vehicles equipped with hydropneumatic, hydraulic or pneumatic suspension or a device for automatic levelling according to load shall be tested with the vehicle in the most adverse normal running condition specified by the manufacturer.

2.7. "Extreme outer edge" of the vehicle means, in relation to the sides of the vehicle, the plane parallel to the median longitudinal plane of the vehicle coinciding with its outer lateral edge, and, in relation to the front and rear ends, the perpendicular transverse plane of the vehicle coinciding with its outer front and rear edges, account not being taken of the projection:

2.7.1. of tyres near their point of contact with the ground, and connections for tyre pressure gauges;

2.7.2. of any anti-skid devices which may be mounted on the wheels;

2.7.3. of rear-view mirrors;

2.7.4. of side direction indicator lamps, end outline marker lamps, front and rear position (side) lamps and parking lamps;

2.7.5. in relation to the front and rear ends, of parts mounted on the bumpers, of towing devices and of exhaust pipes;

- 2.8. "The dimension of the projection" of a component mounted on a panel means the dimension determined by the method described in Annex II, item 2.
- 2.9. "The nominal line of a panel" means the line passing through the two points represented by the position of the centre of a sphere when its surface makes its first and last contact with a component during the measuring procedure described in Annex II, item 2.2.'

Item 3 is to be re-worded as follows:

3. APPLICATION FOR EEC TYPE-APPROVAL
- 3.1. Application for EEC type-approval of a vehicle type in respect of its external projections
- 3.1.1. The application for EEC type-approval of a vehicle type in respect of its external projections shall be submitted by the vehicle manufacturer or by his authorized representative.
- 3.1.2. It shall be accompanied by the undermentioned documents in triplicate:
- 3.1.2.1. photographs of the front, rear, and side parts of the vehicle taken at an angle of 30° to 45° to the vertical longitudinal median plane of the vehicle;
- 3.1.2.2. drawings of the bumpers;
- 3.1.2.3. where appropriate, drawings of specific external projections and, if necessary, of certain sections of the external surface referred to in item 6.9.1.
- 3.1.3. A vehicle representative of the type of vehicle to be approved shall be submitted to the technical service responsible for type-approval. At the request of the technical service, the specific components or samples of the materials used shall likewise be submitted.
- 3.2. Application for EEC type-approval in respect of luggage racks, ski racks or radio receiving or transmitting aerials considered to be separate technical units
- 3.2.1. Applications for EEC type-approval in respect of luggage racks, ski racks or radio receiving or transmitting aerials considered to be separate technical units within the meaning of Article 9a of Directive 70/156/EEC shall be submitted by the vehicle manufacturer or the manufacturer of the aforementioned separate technical units, or by their authorized representative.
- 3.2.2. For every type of any one of the devices referred to in item 3.2.1 above, the application shall be accompanied by the following:
- 3.2.2.1. triplicate copies of documents specifying the technical characteristics of the separate technical unit and the assembly instructions to be supplied with every separate technical unit sold;
- 3.2.2.2. a specimen of the type of separate technical unit. Should the responsible authority consider it necessary, it may request a further specimen. The specimens shall be clearly and indelibly inscribed with the mark specified in Article 9a (3) of Directive 70/156/EEC. As far as luggage racks and ski racks are concerned, provision shall be made for the subsequent compulsory display of the EEC type-approval number. The type-approval number shall be preceded by the international registration letter(s) of the country granting such approval ⁽¹⁾.

Item 4.6 is to be re-worded as follows:

- 4.6.1. When approval is granted for an application under item 3.1, a form conforming to the model in Annex III shall be attached to the type-approval certificate.
- 4.6.2. When approval is granted for an application under item 3.2, a form conforming to the model in Annex IV shall be issued.
- 4.6.3. Where reference is made in an application under item 3.1 to a form of the type illustrated in Annex IV, the scope of the vehicle test shall be reduced accordingly in respect of the external projections. In such cases, the type-approval certificate for the vehicle shall be accompanied by a copy of the type-approval certificate for the separate technical unit.'

(1) B = Belgium, D = Germany, DK = Denmark, F = France, GB = United Kingdom, I = Italy, IRL = Ireland, L = Luxembourg, NL = Netherlands.

Item 5.1.3 is to be re-worded as follows:

'5.1.3. so located that, in their static condition as well as when in operation, they cannot be contacted by a sphere 100 mm in diameter.'

Item 5.4 is to be re-worded as follows:

'5.4. No protruding part of the external surface shall have a radius of curvature less than 2.5 mm. This requirement shall not apply to parts of the external surface which protrude less than 5 mm, but the outward facing angles of such parts shall be blunted, save where such parts protrude less than 1.5 mm.'

Item 5.5 the following sentences shall be added:

'The hardness measurement shall be taken with the component as installed on the vehicle. Where it is impossible to carry out a hardness measurement by the Shore A procedure, comparable measurements shall be used for evaluation.'

After item 5.5, the following new item 5.6 shall be added:

'5.6. The provisions of the above items 5.1 to 5.5 shall apply in addition to the particular specifications of the following item 6, except where these particular specifications expressly provide otherwise.'

Item 6.1.1 the following sentences shall be added:

'To apply the 10 daN force a flat-ended ram of not more than 50 mm diameter shall be used. Where this is not possible, an equivalent method shall be used. After the ornaments are retracted, detached or bent over, the remaining projections shall not project more than 10 mm. These projections shall in any case satisfy the provisions of item 5.2. If the ornament is mounted on a base, this base is regarded as belonging to the ornament and not to the supporting surface.'

Item 6.1.3 shall be deleted.

Item 6.2.1 shall be completed as follows:

'In the case of a headlight mounted behind an additional transparent surface, the projection shall be measured from the outermost transparent surface. The projections shall be determined according to the method described in item 3 of Annex II.'

After item 6.2.2, the following new item 6.2.3 shall be added:

'6.2.3. The provisions of item 6.2.1 above do not apply to headlights which are sunk into the bodywork or which are "overhung" by the bodywork, if the latter complies with the requirements of item 6.9.1.'

Item 6.3.1 is to be re-worded as follows:

'6.3.1. The requirements of item 5.4 shall not apply to gaps between fixed or movable elements, including those forming part of air intake or outlet grilles and radiator grilles, provided that the distance between consecutive elements does not exceed 40 mm and provided that the grilles and gaps have a functional purpose. For gaps of between 40 mm and 25 mm the radii of curvature shall be 1 mm or more. However, if the distance between two consecutive elements is equal to or less than 25 mm, the radii of curvature of external faces of the elements shall not be less than 0.5 mm. The distance between two consecutive elements of grilles and gaps shall be determined according to the method described in item 4 of Annex II.'

Item 6.4.1 is to be re-worded as follows:

'6.4.1. The windscreen wiper fittings shall be such that the wiper shaft is furnished with a protective casing which has a radius of curvature meeting the requirements of item 5.4 above and an end surface area of not less than 150 mm². In the case of rounded covers, these shall have a minimum projected area of 150 mm² when measured not more than 6.5 mm from the point projecting furthest. These requirements shall also be met by rear window wipers and headlight wipers.'

Item 6.4.2 is to be re-worded as follows:

'6.4.2. Item 5.4 shall not apply to the wiper blades or to any supporting members. However, these units shall be so made as to have no sharp angles or pointed or cutting parts.'

Item 6.5.1 is to be re-worded as follows:

- '6.5.1. The ends of the bumpers shall be turned in towards the external surface in order to minimize the risk of fouling. This requirement is considered to be satisfied if either the bumper is recessed or integrated within the bodywork or the end of the bumper is turned in so that it is not contactable by a 100 mm sphere and the gap between the bumper end and the surrounding bodywork does not exceed 20 mm.'

After item 6.5.2 the following new item 6.5.3 shall be added:

- '6.5.3. The requirement of item 6.5.2 shall not apply to parts on or of the bumper or to bumper insets which have a projection of less than 5 mm, with special reference to joint covers and jets for headlight washers; but the outward facing angles of such parts shall be blunted, save where such parts protrude less than 1.5 mm.'

Item 6.6 is to be re-worded as follows:

- '6.6. **Handles, hinges and push-buttons of doors, luggage compartments and bonnets; fuel tank filler caps and covers**

6.6.1. The projection shall not exceed 40 mm in the case of door or luggage compartment handles and 30 mm in all other cases.

6.6.2. If lateral door handles rotate to operate, they shall meet one or other of the following requirements:

6.6.2.1. In the case of handles which rotate parallel to the plane of the door the open end of handles must be directed towards the rear. The end of such handles shall be turned back towards the plane of the door and fitted into a protective surround or be recessed.

6.6.2.2. Handles which pivot outwards in any direction which is not parallel to the plane of the door shall, when in the closed position, be enclosed in a protective surround or be recessed. The open end shall face either rearwards or downwards.

Nevertheless, handles which do not comply with this last condition may be accepted if:

- they have an independent return mechanism,
- should the return mechanisms fail, they cannot project more than 15 mm,
- they comply, in such opened position, with the provisions of item 5.4, and
- their end surface area, when measured not more than 6.5 mm from the point projecting furthest, is not less than 150 mm².

Item 6.7 is to be re-worded as follows:

- '6.7. **Wheels, wheel nuts, hub caps and wheel discs**

Item 6.7.2 is to be re-worded as follows:

- '6.7.2. The wheels, wheel nuts, hub caps and wheel discs shall not exhibit any pointed or sharp projections that extend beyond the external plane of the wheel rim. Wing nuts shall not be allowed.'

Item 6.8.1 the following new sentence shall be added:

'An unprotected edge shall be considered to be folded back either if it is folded back by approximately 180°, or if it is folded towards the bodywork in such a manner that it cannot be contacted by a sphere having a diameter of 100 mm.'

Item 6.9.1 last line shall read:

'... Annex II, item 1.' instead of '... Annex II.'

Item 6.11 is to be re-worded as follows:

- '6.11. **Jacking brackets and exhaust pipes**

6.11.1. The jacking brackets and exhaust pipe(s) shall not project more than 10 mm beyond the vertical projection of the floor line lying vertically above them. As an exception to this requirement an exhaust pipe may project more than 10 mm beyond the vertical projection of the floor line, so long as it terminates in rounded edges, the minimum radius of curvature being 2.5 mm.'

After item 6.11 the following new items 6.12 to 6.18 shall be added:

6.12. Air intake and outlet flaps

- 6.12.1. Air intake and outlet flaps shall meet the requirements of items 5.2, 5.3 and 5.4 in all positions of use.

6.13. Roof

- 6.13.1. Opening roofs shall be considered only in the closed position.
- 6.13.2. Convertible vehicles shall be examined with the hood in both the raised and lowered positions.
- 6.13.2.1. With the hood lowered, no examination shall be made of the vehicle inside an imaginary surface formed by the hood when in the raised position.
- 6.13.2.2. Where a cover for the linkage of the hood when folded is provided as standard equipment, the examination shall be made with the cover in position.

6.14. Windows

- 6.14.1. Windows which move outwards from the external surface of the vehicle shall comply with the following provisions in all positions of use:
- 6.14.1.1. no exposed edge shall face forwards;
- 6.14.1.2. no part of the window shall project beyond the extreme outer edge of the vehicle.

6.15. Registration plate brackets

- 6.15.1. Supporting brackets provided by the vehicle manufacturer for registration plates shall comply with the requirements of item 5.4 of this Annex if they are contactable by a 100 mm diameter sphere when a registration plate is fitted in accordance with the vehicle manufacturer's recommendation.

6.16. Luggage racks and ski racks

- 6.16.1. Luggage racks and ski racks shall be so attached to the vehicle that positive locking exists in at least one direction and that horizontal, longitudinal and transverse forces can be transmitted which are at least equal to the vertical load-bearing capacity of the rack as specified by its manufacturer. For the test of the luggage rack or ski rack fixed to the vehicle according to the manufacturer's instructions, the test loads shall not be applied at one point only.
- 6.16.2. Surfaces which, after installation of the rack, can be contacted by a sphere of 165 mm diameter shall not have parts with a radius of curvature less than 2.5 mm, unless the provisions of 6.3 can be applied.
- 6.16.3. Fastening elements such as bolts that are tightened or loosened without tools shall not project more than 40 mm beyond the surfaces referred to in 6.16.2, the projection being determined according to the method prescribed in Annex II, item 2, but using a sphere of 165 mm diameter in those cases where the method prescribed in item 2.2 of that Annex is employed.

6.17. Radio receiving or transmitting aerials

- 6.17.1. Radio receiving or transmitting aerials shall be fitted to the vehicle in such a way that if their unattached end is less than 2 m from the road surface in any position of use specified by the manufacturer of the aerial, it shall be inside the zone bounded by the vertical planes which are 10 cm inside the extreme outer edge of the vehicle as defined in item 2.7.
- 6.17.2. Furthermore, aerials shall be so fitted to the vehicle, and if necessary their unattached ends so restricted, that no part of the aerials protrude beyond the extreme outer edge of the vehicle as defined in item 2.7.
- 6.17.3. Shafts of aerials may have radii of curvature of less than 2.5 mm. However, the unattached ends shall be fitted with fixed cappings, the radii of curvature of which are not less than 2.5 mm.
- 6.17.4. The bases of aerials shall not project more than 30 mm when determined according to the procedure of Annex II, item 2. However, in the case of aerials with amplifiers built into the base, these bases may project up to 40 mm.

6.18. Assembly instructions

- 6.18.1. Luggage racks, ski racks and radio receiving or transmitting aeri^{als} that have been type-approved as separate technical units may not be offered for sale, sold or purchased unless accompanied by assembly instructions. The assembly instructions shall contain sufficient information to enable the approved components to be mounted on the vehicle in a manner that complies with the relevant provisions of items 5 and 6. In particular, the positions of use must be indicated for telescopic aeri^{als}.

ANNEX II: The title is to be re-worded as follows:

'METHODS OF DETERMINING THE DIMENSIONS OF PROJECTIONS AND GAPS'

Item 1 is to be re-worded as follows:

- '1. METHOD OF DETERMINING THE HEIGHT OF THE PROJECTION OF FOLDS IN BODY PANELS'

The present items 1, 2, 3 and 4 are renumbered and become items 1.1, 1.2, 1.3 and 1.4.

After item 1, the following new items 2, 3 and 4 shall be added:

2. METHOD OF DETERMINING THE DIMENSION OF THE PROJECTION OF A COMPONENT MOUNTED ON THE EXTERNA L SURFACE
- 2.1. The dimension of the projection of a component which is mounted on a convex surface may be determined either directly or by reference to a drawing of an appropriate section of this component in its installed condition.
- 2.2. If the dimension of the projection of a component which is mounted on a surface other than convex cannot be determined by simple measurement, it shall be determined by the maximum variation of the distance of the centre of a 100 mm diameter sphere from the nominal line of the panel when the sphere is moved over and is in constant contact with that component. Figure 3 shows an example of the use of this procedure.
3. METHOD OF DETERMINING THE PROJECTION OF HEADLIGHT VISORS AND RIMS
- 3.1. The projection from the external surface of the headlight shall be measured horizontally from the point of contact of a 100 mm diameter sphere as shown in Figure 4.
4. METHOD OF DETERMINING THE DIMENSION OF A GAP OR THE SPACE BETWEEN ELEMENTS OF A GRILLE
- 4.1. The dimension of a gap or space between elements of a grille shall be determined by the distance between two planes passing through the points of contact of the sphere and perpendicular to the line joining those points of contact. Figures 5 and 6 show examples of the use of this procedure.'

After Figure 2 add Figures 3 to 6.

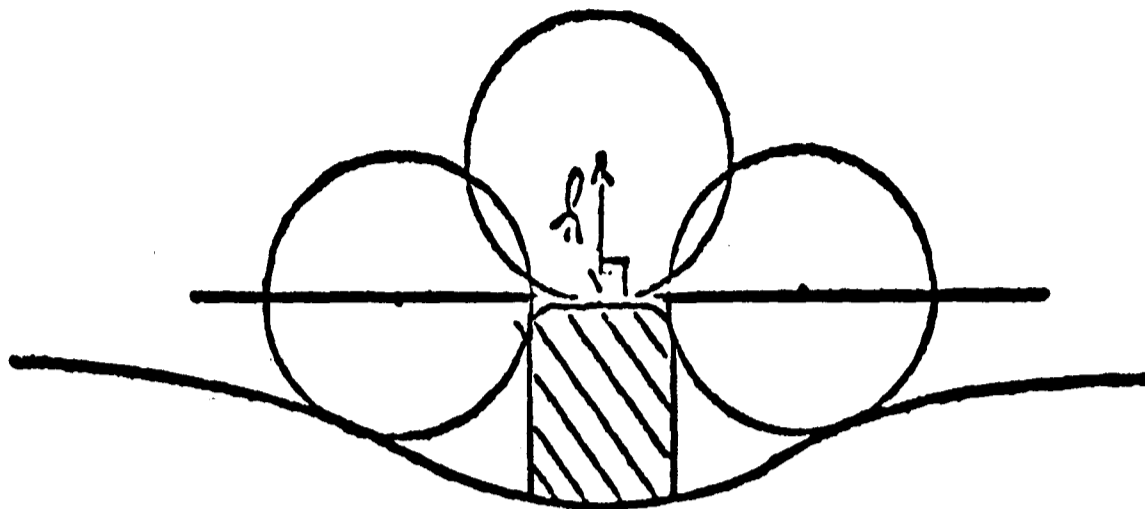

Figure 3

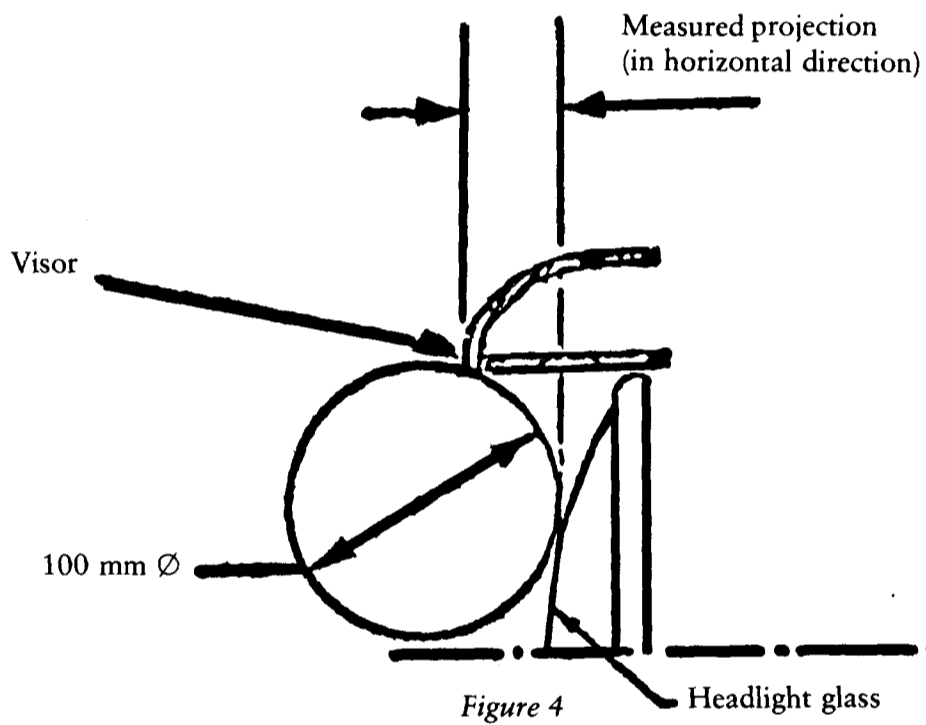

Figure 4

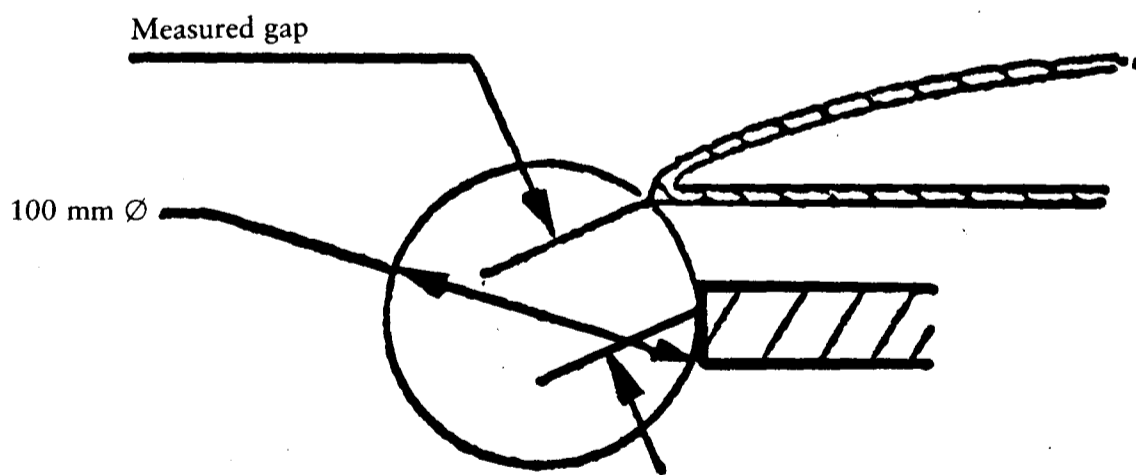

Figure 5

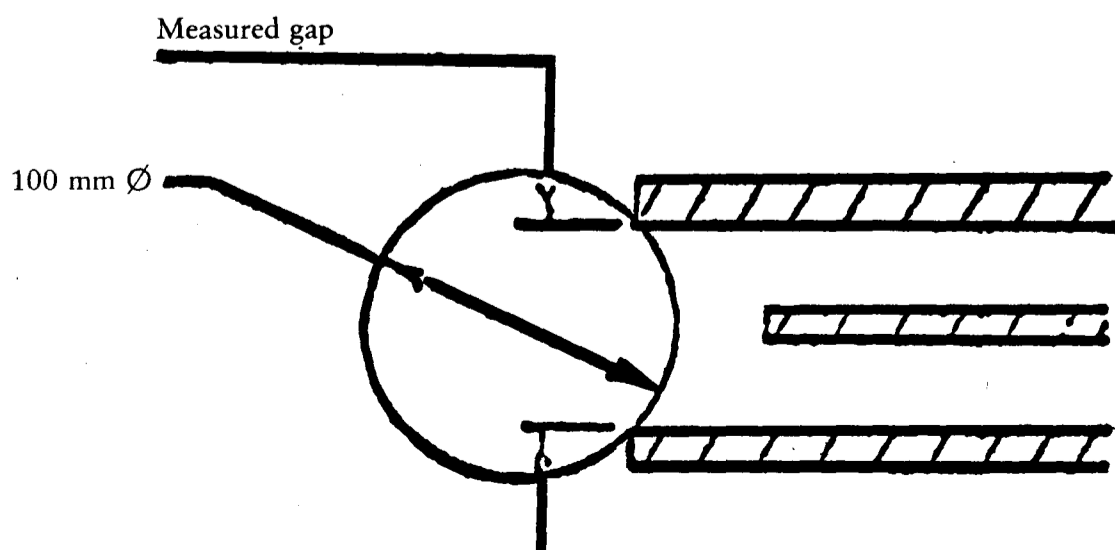

Figure 6

ANNEX III: The title is to be re-worded as follows:

'ANNEX III

MODEL

Name of administration

ANNEX TO THE EEC TYPE-APPROVAL CERTIFICATE WITH REGARD TO EXTERNAL PROJECTIONS

(Articles 4 (2) and 10 of the Council Directive of 6 February 1970 on the approximation of the laws of the Member States relating to the type-approval of motor vehicles and their trailers)

Having regard to the amendments in accordance with Directive 79/488/EEC'

After Annex III the following new Annex IV shall be added:

ANNEX IV

MODEL

(Maximum format: A4 (210 x 297 mm))

Name of administration

EEC TYPE-APPROVAL CERTIFICATE FOR A SEPARATE TECHNICAL UNIT

(Article 9a of Council Directive 70/156/EEC of 6 February 1970 on the approximation of the laws of the Member States relating to the type-approval of motor vehicles and their trailers)

Separate technical unit: type of luggage rack, ski rack, radio receiving or transmitting aerial (1)

EEC type-approval number for the separate technical unit

- 1. Trade name or mark
- 2. Type
- 3. Manufacturer's name and address
- 4. Name and address of manufacturer's authorized representative, if any
- 5. Characteristics of the separate technical unit
- 6. Limitations of use, if any, and assembly instructions
- 7. Specimen required for EEC type-approval of a separate technical unit submitted on
- 8. Technical service
- 9. Date of test report issued by that service
- 10. Number of test report issued by that service
- 11. EEC type-approval for separate technical units has been granted/refused (1) in respect of the luggage rack(s), ski rack(s), radio receiving or transmitting aerial(s) (1)
- 12. Place
- 13. Date
- 14. Signature
- 15. The following documents, bearing the abovementioned EEC type-approval number for a separate technical unit, are annexed to this certificate: (give details where appropriate)
- 16. Remarks

(1) Delete as appropriate.