

This document is meant purely as a documentation tool and the institutions do not assume any liability for its contents

► **B**

COUNCIL DIRECTIVE

of 18 December 1975

**on the approximation of the laws of the Member States relating to anchorages for motor-vehicle
safety belts**

(76/115/EEC)

(OJ L 24, 30.1.1976, p. 6)

Amended by:

	Official Journal		
	No	page	date
► <u>M1</u> Council Directive 81/575/EEC of 20 July 1981	L 209	30	29.7.1981

▼B**COUNCIL DIRECTIVE****of 18 December 1975****on the approximation of the laws of the Member States relating to anchorages for motor-vehicle safety belts**

(76/115/EEC)

THE COUNCIL OF THE EUROPEAN COMMUNITIES,

Having regard to the Treaty establishing the European Economic Community, and in particular Article 100 thereof,

Having regard to the proposal from the Commission,

Having regard to the opinion of the European Parliament ⁽¹⁾,Having regard to the opinion of the Economic and Social Committee ⁽²⁾,Whereas the technical requirements with which motor vehicles must comply pursuant to national laws relate *inter alia* to safety belt anchorages;Whereas those requirements differ from one Member State to another; whereas it is therefore necessary that all Member States adopt the same requirements, either in addition to or in place of their existing rules, in order, in particular, to allow the EEC type-approval procedure, which was the subject of Council Directive 70/156/EEC of 6 February 1970 on the approximation of the laws of the Member States relating to the type approval of motor vehicles and their trailers ⁽³⁾, to be introduced in respect of each type of vehicle;Whereas common requirements for the interior fittings of the passenger compartment, the layout of the controls, the roof, the backrest and rear part of the seats were laid down by Directive 74/60/EEC ⁽⁴⁾; whereas common requirements on interior fittings relating to the behaviour of the steering mechanism in the event of impact were laid down by Directive 74/297/EEC ⁽⁵⁾; whereas common requirements concerning the strength of seats and their anchorages were laid down by Directive 74/408/EEC ⁽⁶⁾; whereas other requirements will be adopted subsequently concerning interior fittings, and in particular safety belts, head restraints and the identification of controls;

Whereas approximation of the national laws relating to motor vehicles entails recognition by the Member States of the checks carried out by each of them on the basis of the common requirements; whereas, for it to operate effectively, such a system calls for the implementation of these requirements by all of the Member States with effect from the same date,

HAS ADOPTED THIS DIRECTIVE:

Article 1

This Directive applies to anchorages for motor vehicle safety belts intended for adult occupants of forward-facing seats.

▼M1*Article 2*

For the purposes of this Directive, 'vehicle' means any motor vehicle in categories M and N as defined in Annex I to Directive 70/156/EEC

⁽¹⁾ OJ No C 5, 8. 1. 1975, p. 41.⁽²⁾ OJ No C 47, 27. 2. 1975, p. 45.⁽³⁾ OJ No L 42, 23. 2. 1970, p. 1.⁽⁴⁾ OJ No L 38, 11. 2. 1974, p. 2.⁽⁵⁾ OJ No L 165, 20. 6. 1974, p. 16.⁽⁶⁾ OJ No L 221, 12. 8. 1974, p. 1.

▼ M1

intended for use on the road, having at least four wheels and a maximum design speed exceeding 25 km/h.

▼ B*Article 3*

No Member State may refuse to grant EEC type-approval or national type-approval of a motor vehicle on grounds relating to the anchorages for safety belts if these anchorages comply with the requirements laid down in Annexes I, III and IV.

Article 4

No Member State may refuse or prohibit the sale, registration, entry into service or use of any motor vehicle on grounds relating to the anchorages for safety belts if these anchorages comply with the requirements laid down in Annexes I, III and IV.

Article 5

A Member State which has granted type-approval shall take the necessary measures to ensure that it is informed of any modification to any of the parts or characteristics referred to in Annex I, point 1.1. The competent authorities of that Member State shall determine whether fresh tests should be carried out on the modified vehicle type and a fresh report drawn up. Where such tests reveal failure to comply with the requirements of this Directive, the modification shall not be approved.

Article 6

Any amendments necessary to adjust the requirements of the Annexes to take account of technical progress shall be adopted in accordance with the procedure laid down in Article 13 of Directive 70/156/EEC.

Article 7

1. Member States shall, before 1 October 1976, adopt and publish the provisions necessary to comply with this Directive and shall immediately inform the Commission thereof.

They shall apply these provisions with effect from 1 January 1977.

2. Once this Directive has been notified, the Member States shall also ensure that the Commission is informed of all draft laws, regulations or administrative provisions which they propose to adopt in the field covered by this Directive in sufficient time to enable it to submit its comments.

Article 8

This Directive is addressed to the Member States.

▼B

ANNEX I

**DEFINITIONS, APPLICATION FOR EEC TYPE-APPROVAL, EEC
TYPE-APPROVAL, SPECIFICATIONS, TESTS, CONFORMITY OF
PRODUCTION, INSTRUCTIONS**

1. DEFINITIONS

For the purpose of this Directive:

- 1.1. *'vehicle type'* as regards safety belt anchorages means a category of vehicles which do not differ in such essential respects as:
- the dimensions, lines and constituent materials of the components of the vehicle structure or seat structure or any other part of the vehicle to which the belt anchorages are attached;
- 1.2. *'belt anchorages'* means the parts of the vehicle structure or seat structure or any other part of the vehicle to which the safety belt assemblies are to be secured;
- 1.3. *'safety belt'* (or *'seat belt'* or *'belt'*) means an arrangement of straps with a securing buckle, adjusting devices and attachments which is capable of being anchored to a vehicle and is designed to diminish the risk of injury to its wearer, in the event of collision or abrupt vehicle deceleration, by limiting the mobility of the wearer's body. Such an arrangement is generally referred to as a 'belt assembly', a term also embracing any device for energy absorption or belt retraction;
- 1.4. *'strap guide'* means a device which alters the lie of the strap in relation to the wearer of the belt assembly.
- 1.5. *'effective belt anchorage'* means the point used to determine, as specified in point 4.4, the angle of each part of the safety belt in relation to the wearer, that is, the point to which a strap would need to be attached to provide the same lie as the intended lie of the belt when worn, and which may or may not be the actual belt anchorage depending on the configuration of the safety belt hardware at its attachment to the belt anchorage, for example, in the case:
- 1.5.1. where a safety belt incorporates a rigid part which is attached to a lower belt anchorage and which is either fixed or free to swivel, the effective belt anchorage for all positions of seat adjustment is the point at which the strap is attached to that rigid part,
- 1.5.2. where a strap guide is used on the vehicle structure or on the seat structure, the middle point of the guide at the place where the strap leaves the guide on the belt wearer's side shall be regarded as the effective belt anchorage; the strap shall lie in a straight line between the effective belt anchorage and the wearer,
- 1.5.3. where the belt runs directly from the wearer to a retractor attached to the vehicle structure or the seat structure without an intervening strap guide, the effective belt anchorage shall be considered as being the intersection of the axis of the reel for storing the strap with the plane passing through the centre line of the strap on the reel;
- 1.6. *'seat'* means a structure which may or may not be integral with the vehicle structure complete with trim, intended to seat one adult person. The term covers both an individual seat or part of a bench seat intended to seat one person;
- 1.7. *'bench seat'* means a structure complete with trim, intended to seat at least two adults;
- 1.8. *'group of seats'* means either a bench-type seat, or seats which are separate but side by side (i.e. fixed so that the front seat anchorages of one of these seats are in line with the front or rear anchorages of the other or between the anchorages of the other seat) and seat one or more adults;
- 1.9. *'folding (tip-up) seat'* means an auxiliary seat intended for occasional use and which is normally folded out of the way;
- 1.10. *'seat type'* means a category of seats which do not differ in such essential respects as:
- 1.10.1. the shape, dimensions and materials of the seat structure,
- 1.10.2. the types and dimensions of the adjustment systems and all locking systems,

▼B

- 1.10.3. the type and dimensions of the belt anchorages on the seat, of the seat anchorage and of the affected parts of the vehicle structure;
- 1.11. '*seat anchorage*' means the system by which the seat assembly is secured to the vehicle structure, including the affected parts of the vehicle structure;
- 1.12. '*adjustment system*' means the device by which the seat or its parts can be adjusted to a position suited to the morphology of the seated occupant; this device may, in particular, allow:
 - 1.12.1. longitudinal displacement,
 - 1.12.2. vertical displacement,
 - 1.12.3. angular displacement,
- 1.13. '*displacement system*' means a device enabling the seat or one of its parts to be displaced angularly or longitudinally, without a fixed intermediate position, to facilitate passenger access;
- 1.14. '*locking system*' means any device ensuring that the seat and its parts are maintained in any position of use and includes both devices to lock the seat back relative to the seat and the seat relative to the vehicle.

2. APPLICATION FOR EEC TYPE-APPROVAL

- 2.1. The application for EEC type-approval of a vehicle type with regard to safety belt anchorages shall be submitted by the vehicle manufacturer or his representative.
- 2.2. It shall be accompanied by the undermentioned documents in triplicate and the following particulars:
 - 2.2.1. general arrangement drawings of the vehicle structure on an appropriate scale, showing the location of the belt anchorages, and detailed drawings of the belt anchorages and the structure to which they are attached;
 - 2.2.2. a specification of the materials used which may affect the strength of the belt anchorages;
 - 2.2.3. a technical description of the belt anchorages;
 - 2.2.4. in the case of belt anchorages affixed to the seat structure, a detailed description of the vehicle type with respect to the design of the seats, the seat anchorages and their adjustment and locking systems;
 - 2.2.5. drawings, on an appropriate scale and in sufficient detail, of the seats, their anchorage to the vehicle and their adjustment and locking systems.
- 2.3. The manufacturer shall submit to the technical service either a vehicle representative of the vehicle type to be approved or the parts of the vehicle considered essential for the belt anchorage tests by the technical service responsible for conducting the approval tests.

3. EEC TYPE-APPROVAL

- 3.1. A form conforming to the model set out in Annex II shall be attached to the EEC type-approval certificate.

4. SPECIFICATIONS

4.1. Definitions (see Annex III)

- 4.1.1. Point H is a reference point determined by the procedure prescribed in Annex IV to Directive 74/60/EEC.
- 4.1.2. The reference line is a straight line passing through the joint of the leg with the pelvis and the joint of the neck with the thorax of the manikin illustrated in figure 2 of Annex IV to Directive 74/60/EEC and representing a 50th percentile adult male.

▼B

- 4.1.3. Points L_1 and L_2 are the lower effective belt anchorages.
- 4.1.4. Point C is a point situated 450 mm vertically above point H.
- 4.1.5. The angles α_1 and α_2 are respectively the angles between a horizontal plane and planes perpendicular to the median longitudinal plane of the vehicle and passing through point H and points L_1 and L_2 .
- 4.1.6. S is the distance in millimetres of the effective upper belt anchorage from a reference plane P parallel to the longitudinal median plane of the vehicle defined as follows:
- 4.1.6.1. if the seating position is well defined by the shape of the seat, the plane P shall be the median plane of this seat;
- 4.1.6.2. in the absence of a well-defined position:
- 4.1.6.2.1. the plane P for the driver shall be a vertical plane parallel to the median longitudinal plane of the vehicle and passing through the centre of the steering wheel in its mean position, if adjustable;
- 4.1.6.2.2. the plane P for the front outboard passenger shall be symmetrical with that of the driver;
- 4.1.6.2.3. plane P for the rear outboard seating position shall be that specified by the manufacturer on condition that the following limits for distance A between the longitudinal median plane of the vehicle and plane P are respected:
- A \geq 200 mm if the bench seat has been designed to accommodate two passengers only,
- A \geq 300 mm if the bench seat has been designed to accommodate two or three passengers.

4.2. General specifications

- 4.2.1. Anchorages for a safety belt shall be so designed, made and situated as to:
- 4.2.1.1. enable the installation of a suitable safety belt. The belt anchorages of the front outboard positions shall be suitable for safety belts incorporating a retractor and pulley, taking into consideration in particular the strength characteristics of the belt anchorages, unless the manufacturer supplies the vehicle equipped with other types of safety belts which incorporate retractors. If the anchorages are suitable only for particular types of safety belts, their types shall be stated on the form mentioned in point 3.1 above;
- 4.2.1.2. reduce to a minimum the risk of the belt slipping when worn correctly;
- 4.2.1.3. reduce to a minimum the risk of strap damage due to contact with sharp rigid parts of the vehicle or seat structures.
- 4.2.2. For belt anchorages which take up different positions to allow persons to enter the vehicle and for restraining the occupants, the specifications of this Directive shall apply to the belt anchorages in the effective restraint position.

4.3. Minimum number of belt anchorages to be provided**▼M1**

- 4.3.1. For the front seats of vehicles in category M_1 , category M_2 (except vehicles of a permissible maximum weight exceeding 3 500 kg and those which include places specially designed for standing passengers) and categories N_1 , N_2 and N_3 , two lower belt anchorages and one upper belt anchorage must be provided. However, for front central seats, two lower belt anchorages are considered as sufficient where the windscreen is located outside the reference zone defined in Annex II to Directive 74/60/EEC. As regards the belt anchorages, the windscreen is considered part of the reference zone where it is capable of entering into static contact with the test apparatus according to the method described in Annex II.

▼ M1

4.3.2. For the other outboard seats of vehicles in category M₁, there must be two lower belt anchorages and one upper belt anchorage.

4.3.3. For all other seats in category M₁ vehicles, and for all other non-protected seats in categories other than M₁ as referred to in 4.3.1, there must be a minimum of two lower belt anchorages.

For the purpose of defining 'protected seat', 'protection area' means the area in front of a seat and contained:

- between two horizontal planes, one through the H point and the other 400 mm above it;
- between two vertical longitudinal planes which are symmetrical in relation to the H point and are 400 mm apart;
- behind a transverse vertical plane 1.30 m from the H point.

Within any transverse vertical plane, 'screen zone' means a continuous surface such that, if a sphere of 165 mm diameter is projected in a longitudinal horizontal direction through any point of the zone and through the centre of the sphere, nowhere in the protection area is there any aperture through which the sphere can be passed.

A seat is considered to be protected if the screen zones within the protection area have a combined surface area of at least 800 cm².

4.3.4. For all folding (tip-up) seats, as well as all the seats of any vehicle which are not covered by sections 4.3.1, 4.3.2 or 4.3.3, not belt anchorages are required. However, if the vehicle is fitted with anchorages for such seats, these anchorages must comply with the provisions of this Directive.

▼ B

4.4. Location for belt anchorages

4.4.1. The location of the belt anchorages as laid down in point 4.3 must comply with the following requirements.

4.4.2. *General*

4.4.2.1. The belt anchorages for any one belt may be located wholly in the vehicle structure, the seat structure or any other part of the vehicle or may be dispersed between these locations.

4.4.2.2. Any one belt anchorage may be used for attaching the ends of two adjacent safety belts provided that the test requirements are met.

4.4.2.3. In the case of a bench seat provided with belt anchorages for two or more seating positions the lower belt anchorages shall all be either integral with the seat or in the body structure. A similar requirement shall also apply to upper belt anchorages.

4.4.3. *Location of the effective lower belt anchorages*

4.4.3.1. The angles α_1 and α_2 shall be within the range of 30° to 80° in all normal travelling positions of the seat. Where, in the case of the front seats, there is no seat adjustment or where the belt anchorages are on the seat itself, the angles α_1 and α_2 shall be 60° ± 10°.

4.4.3.2. In the case of the rear seats, the angles α_1 and α_2 may be less than the minimum specified in point 4.4.3.1 provided they are not less than 20°.

4.4.3.3. The distance between the two vertical planes parallel to the median longitudinal plane of the seat and each passing through a different one of two effective lower anchorages L₁ and L₂ of the same seat belt shall not be less than 350 mm.

▼B

The median longitudinal plane of the seat shall pass between points L_1 and L_2 and shall be at least 120 mm from those points.

4.4.4. *Location of the effective upper belt anchorage*

4.4.4.1. In the case where a strap guide or similar device is used which affects the location of the effective upper belt anchorage, this location will be determined in a conventional way by considering the position of the anchorage when the longitudinal centre line of the strap passes through a point J defined successively from point H by the following three segments:

HZ, which is a segment of the reference line measured in an upward direction from point H and 530 mm long;

ZX, which is a segment perpendicular to the median longitudinal plane of the vehicle, measured from point Z in the direction of the anchorage and 120 mm long;

XJ, which is a segment perpendicular to the plane defined by segments HZ and ZX, measured in a forward direction from point X and 60 mm long.

4.4.4.2. If located to the rear of a plane perpendicular to the median longitudinal plane of the seat and passing through the reference line, the effective upper belt anchorage shall lie below the plane FN perpendicular to the median longitudinal plane of the seat and forming an angle of 65° to the reference line. In the case of rear seats this angle may be reduced to 60° . The plane FN is so positioned that it intersects the reference line at a point D such that DH equals $315 \text{ mm} + 1.6 S$.

If located on or forward of a plane perpendicular to the median longitudinal plane of the seat and passing through the reference line, the effective upper belt anchorage shall be below the plane F_1N_1 perpendicular to the median longitudinal plane of the seat and forming an angle of 65° to the reference line. In the case of rear seats, this angle may be reduced to 60° . The plane F_1N_1 is so positioned that it intersects the reference line at a point D' such that D'H equals $315 \text{ mm} + 1.8 S$.

4.4.4.3. If located to the rear of a plane perpendicular to the median longitudinal plane of the seat and passing through the reference line, the effective upper belt anchorage shall lie behind a plane FK, perpendicular to the median longitudinal plane of the seat, intersecting the reference line at an angle of 120° at a point B such that BH equals $260 \text{ mm} + 1.2 S$.

If located on or forward of a plane perpendicular to the median longitudinal plane of the seat and passing through the reference line, the effective upper belt anchorage shall lie behind a plane F_1K_1 perpendicular to the median longitudinal plane of the seat, intersecting the reference line at an angle of 120° at a point B' such that B'H equals $260 \text{ mm} + S$.

4.4.4.4. The value of S shall not be less than 140 mm.

4.4.4.5. The effective upper belt anchorage shall be situated to the rear of a vertical plane perpendicular to the median longitudinal plane of the vehicle and passing through the H point as shown in Annex III.

4.4.4.6. The effective upper belt anchorage shall be situated above the horizontal plane passing through point C.

4.4.4.7. By way of derogation from the requirement of point 4.4.4.6 and until 1 January 1979, the effective upper belt anchorage may be placed in the area included between horizontal plane CY and plane CM perpendicular to the median longitudinal plane of the vehicle and forming a 20 degree angle with plane CY where the configuration of the vehicle does not allow the location of this anchorage above the plane CY. The seat back may not be lower than the height of a horizontal plane through point C and a strap guide must be provided to prevent the strap from sliding off the shoulder. When tested in accordance with point 5, the point supporting the strap on the seat back shall remain above the plane CM.

▼B**4.5. Dimensions of threaded belt anchorage holes**

4.5.1. A belt anchorage shall have a threaded hole of 11·11 mm (7/16) 20 UNF 2B.

5. TESTING**5.1. General**

5.1.1. Subject to application of the provisions of point 5.2 and at the request of the manufacturer:

5.1.1.1. the tests may be carried out on either a vehicle structure or a completely finished vehicle;

5.1.1.2. windows and doors may or may not be fitted and/or closed;

5.1.1.3. any fitting provided in the vehicle type and likely to contribute to the rigidity of the vehicle structure may be fitted.

5.1.2. The seats shall be fitted and shall be placed in the position for driving or use chosen by the technical service conducting approval tests to give the most adverse conditions with respect to the strength of the system. The position of the seats shall be stated in the report. If the angle between the seat back and the cushion is adjustable, it shall be set as specified in Annex IV, point 2.2 of Directive 74/60/EEC.

5.2. Securing of the vehicle

5.2.1. The method used to secure the vehicle during the test shall not be such as to strengthen the belt anchorages or the belt anchorage areas or to lessen the normal deformation of the structure.

5.2.2. A securing device shall be regarded as satisfactory if it produces no effect on an area extending over the whole width of the structure and if the vehicle or the structure is blocked or fixed in front at a distance of not less than 500 mm from the belt anchorage to be tested and is held or fixed at the rear not less than 300 mm from that anchorage.

5.2.3. It is recommended that the structure should rest on supports arranged approximately in line with the axis of the wheels or, if that is not possible, in line with the points of attachment of the suspension.

5.3. General test specifications

5.3.1. All the belt anchorages of the same group of seats shall be tested simultaneously.

5.3.2. The tractive force shall be applied in a forward direction at an angle of $10^\circ \pm 5^\circ$ above the horizontal in a plane parallel to the median longitudinal plane of the vehicle.

5.3.3. Full application of the load shall be achieved as rapidly as possible. The belt anchorages must withstand the specified load for not less than 0·2 second.

5.3.4. Traction devices to be used in the tests described in point 5.4 below are shown in Annex IV.

5.3.5. The belt anchorages for seats for which upper belt anchorages are provided shall be tested under the following conditions:

5.3.5.1. Front outboard seats:

The belt anchorages shall be submitted to the test prescribed in point 5.4.1 in which the loads are transmitted to them by means of a device reproducing the geometry of a three-point safety belt equipped with a retractor having a pulley or strap guide at the upper belt anchorage.

5.3.5.1.1. In the case where the retractor is not attached to the required outboard lower belt anchorage or in the case where the retractor is attached to the upper belt anchorage, the lower belt anchorages shall also be submitted to the test prescribed in point 5.4.3.

▼B

5.3.5.1.2. In the cases provided for in point 5.3.5.1.1, the tests prescribed in points 5.4.1 and 5.4.3 can be performed on two different structures if the manufacturer so requests.

5.3.5.2. Rear outboard seats and all centre seats:

The belt anchorages shall be subjected to the test prescribed in point 5.4.2, in which the loads are transmitted to them by means of a device reproducing the geometry of a three-point safety belt without a retractor, and to the test prescribed in point 5.4.3, in which the loads are transmitted to the two lower belt anchorages by means of a device reproducing the geometry of a lap belt. The two tests can be performed on two different structures if the manufacturer so requests.

5.3.5.3. By way of derogation from points 5.3.5.1 and 5.3.5.2, when a manufacturer supplies his vehicle with safety belts incorporating retractors, the corresponding belt anchorages shall be submitted to a test in which the loads are transmitted to them by means of a device reproducing the geometry of safety belts for which these anchorages are to be approved.

5.3.6. If no upper belt anchorages are provided for the rear outboard seats and the centre seats, the lower belt anchorages shall be submitted to the test prescribed in point 5.4.3, in which the loads are transmitted to these anchorages by means of a device reproducing the geometry of a lap belt.

5.3.7. If the vehicle is designed to accept other devices which do not enable the straps to be directly attached to belt anchorages without intervening sheaves or other similar devices or which require belt anchorages supplementary to those mentioned in point 4.3, the safety belt or an arrangement of wires, sheaves or other similar devices representing the equipment of the safety belt, shall be attached by such a device to the belt anchorages in the vehicle and the belt anchorages shall be subjected to the tests prescribed in point 5.4, as appropriate.

5.3.8. A test method other than those prescribed in point 5.3 may be used but evidence must be furnished that it is equivalent.

5.4. **Particular test specifications**

5.4.1. *Test in configuration of a three-point belt incorporating a retractor having a pulley or strap guide at the upper belt anchorage*

5.4.1.1. A special pulley or guide for the wire or strap appropriate to transmit the load from the traction device, or the pulley or strap guide supplied by the manufacturer shall be fitted to the upper belt anchorage.

5.4.1.2. A test load of $1\,350\text{ daN} \pm 20\text{ daN}$ shall be applied to a traction device (see Annex IV, figure 2) attached to the belt anchorages of the same belt by means of a device reproducing the geometry of the upper torso strap of such a safety belt.

5.4.1.3. At the same time a tractive force of $1\,350\text{ daN} \pm 20\text{ daN}$ shall be applied to a traction device (see Annex IV, figure 1) attached to the two lower belt anchorages.

5.4.2. *Test in configuration of a three-point belt without retractor or with a retractor at the upper belt anchorage*

5.4.2.1. A test load of $1\,350\text{ daN} \pm 20\text{ daN}$ shall be applied to a traction device (see Annex IV, figure 2) attached to the upper belt anchorage and to the opposite lower belt anchorage of the same belt, using, if supplied by the manufacturer, a retractor fixed at the upper belt anchorage.

5.4.2.2. At the same time a tractive force of $1\,350\text{ daN} \pm 20\text{ daN}$ shall be applied to a traction device (see Annex IV, figure 1) attached to the lower belt anchorages.

5.4.3. *Test in configuration of a lap belt*

A test load of $2\,225\text{ daN} \pm 20\text{ daN}$ shall be applied to a traction device (see Annex IV, figure 1) attached to the two lower belt anchorages.

▼B

5.4.4. *Test for belt anchorages located wholly within the seat structure or dispersed between the vehicle structure and the seat structure*

5.4.4.1. The tests specified in points 5.4.1, 5.4.2 and 5.4.3 shall be performed, as appropriate, at the same time superimposing for each seat and for each group of seats a force as stated below.

5.4.4.2. The loads indicated in points 5.4.1, 5.4.2 and 5.4.3 shall be supplemented by a force equal to 20 times the weight of the complete seat applied horizontally and longitudinally through the centre of gravity of the seat.

5.5. **Results of tests**

5.5.1. All the anchorages shall be capable of withstanding the test prescribed in points 5.3 and 5.4. Permanent deformation, including partial rupture or breakage of any anchorage or surrounding area, shall not constitute failure if the required force is sustained for the specified time. During the test, the minimum spacings for the effective lower belt anchorages specified in point 4.4.3.3 and the requirements of points 4.4.4.6 and 4.4.4.7 for effective upper belt anchorages shall be respected.

5.5.2. In the case of a two-door vehicle, the displacement and locking system enabling the occupants of the rear seats to leave the vehicle must still be operable by hand after removal of the tractive force.

5.5.3. After testing, any damage to the belt anchorages and structures supporting load during tests shall be noted.

6. CONFORMITY OF PRODUCTION

6.1. In order to verify conformity with the approved type, a sufficient number of random checks shall be performed on serially-produced vehicles.

6.2. As a general rule, these checks shall be confined to the taking of measurements. However, if necessary, the vehicles shall be subjected to tests conforming to the requirements of point 5.

7. INSTRUCTIONS

For every vehicle conforming to the approved type, the manufacturer shall state clearly in the instructions for operating the vehicle:

- where the belt anchorages are located,
- the types of safety belt for which they are intended.

▼B

ANNEX II

MODEL

Name of administration

ANNEX TO THE EEC VEHICLE TYPE-APPROVAL CERTIFICATE: APPROVAL OF SAFETY BELT ANCHORAGES

(Article 4 (2) and Article 10 of the Council Directive of 6 February 1970 on the approximation of the laws of the Member States relating to the type-approval of motor vehicles and their trailers)

- EEC type-approval number
1. Trade name or mark of the motor vehicle
 2. Vehicle type
 3. Name and address of manufacturer
 4. Where applicable, name and address of manufacturer's representative
 5. Designation of the types of belts authorized for fitting to the anchorage with which the vehicle is equipped:

			Anchorage ⁽¹⁾	
			Vehicle structure	Seat structure
FRONT	Right-hand seat	{ Lower anchorages Upper anchorage	{ outboard inboard	
	Middle seat	{ Lower anchorages Upper anchorage	{ right left	
	Left-hand seat	{ Lower anchorages Upper anchorage	{ outboard inboard	
REAR	Right-hand seat	{ Lower anchorages Upper anchorage	{ outboard inboard	
	Middle seat	{ Lower anchorages Upper anchorage	{ right left	
	Left-hand seat	{ Lower anchorages Upper anchorage	{ outboard inboard	

Remarks:

⁽¹⁾ Insert in the actual position the following letter or letters:
 'A' for a three-point belt including the case where a retractor is attached directly to the anchorage without a pulley or strap guide at the upper anchorage.
 'B' for a lap belt.
 'S' for special-type belts; in this case the nature of the types under 'Remarks'.
 'Ar', 'Br' or 'Sr' for a belt incorporating retractors using a pulley or strap guide.
 'Ae', 'Be' or 'Se' for a belt with an energy absorption device.
 'Are', 'Bre' or 'Sre' for a belt fitted with a retractor using a pulley or strap guide and an energy absorption device on at least one anchorage.

▼ B

- 6. Description of seats ⁽¹⁾
- 7. Description of adjustment, displacement and locking system either of the seat or seat parts ⁽¹⁾
.....
- 8. Description of seat anchorage ⁽¹⁾
- 9. Description of particular type of safety belt required in the case of an anchorage located
in the seat back or incorporating an energy-dissipating device
-
- 10. Number of report issued by that service
- 11. Type-approval granted/refused ⁽²⁾
- 12. Place
- 13. Date
- 14. Signature
- 15. The following documents, bearing the type-approval number shown above, are annexed to
this certificate:
 - drawings, technical descriptions of the belt anchorages and of the vehicle structure
including photographs where necessary,
 - drawings, technical descriptions of the seats, their vehicle anchorages and adjustment,
displacement and locking systems including photographs where necessary.

⁽¹⁾ Only if the anchorage is affixed on the seat or if the seat supports the belt strap.
⁽²⁾ Delete as appropriate.

▼B

ANNEX III

AREAS OF LOCATIONS OF EFFECTIVE BELT ANCHORAGES

$DH = 315 + 1.6 S$
 $BH = 260 + 1.2 S$
 $D'H = 315 + 1.8 S$
 $B'H = 260 + S$

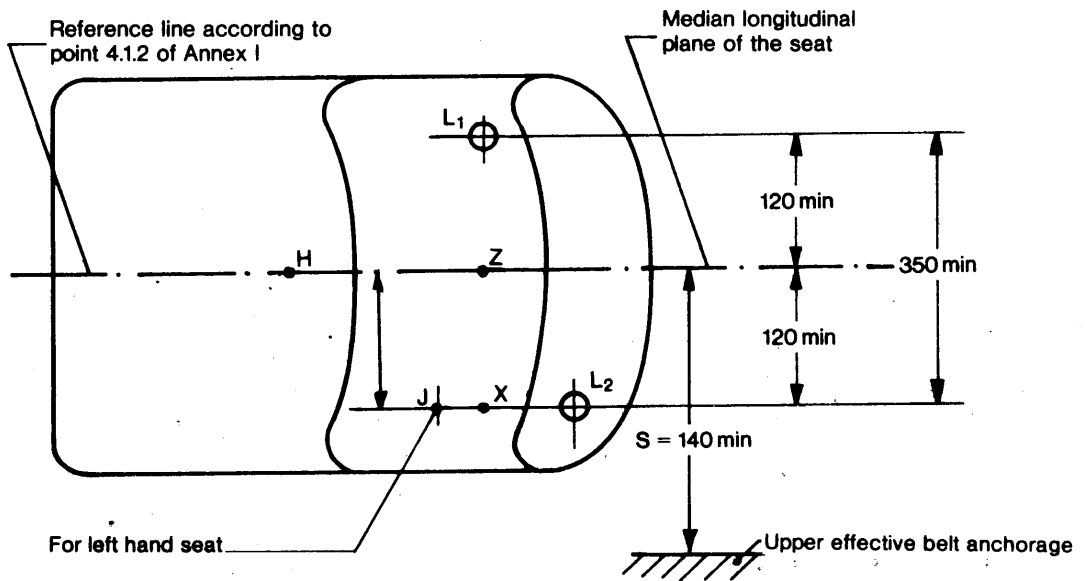
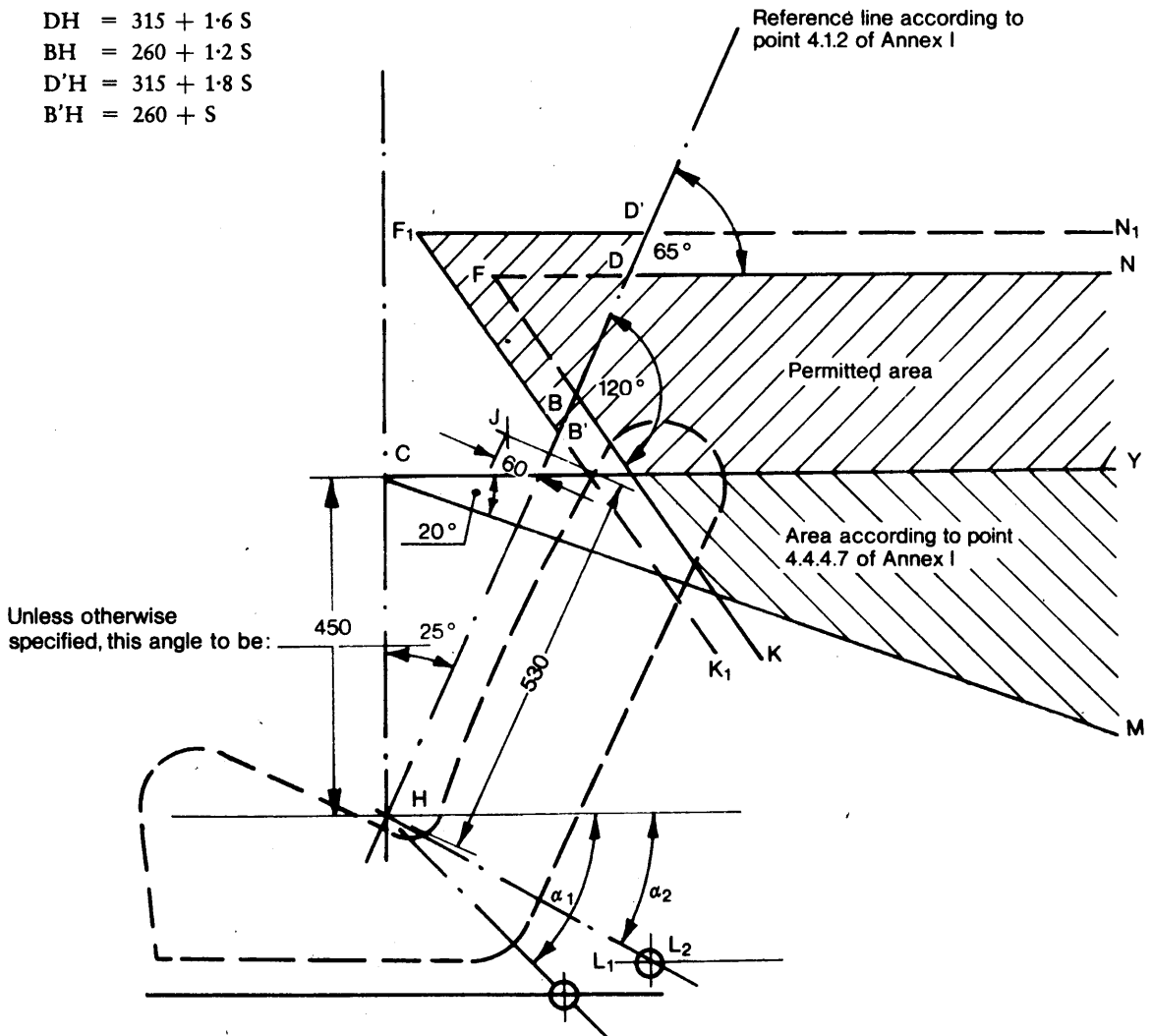

All dimensions are in millimetres

▼B

ANNEX IV

TRACTION DEVICE

Figure 1

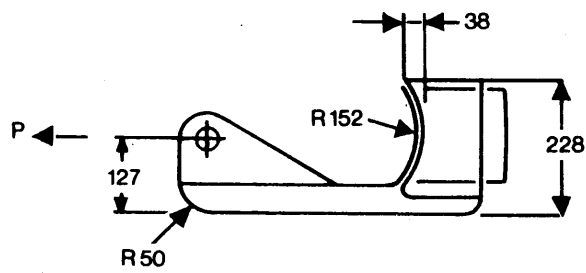
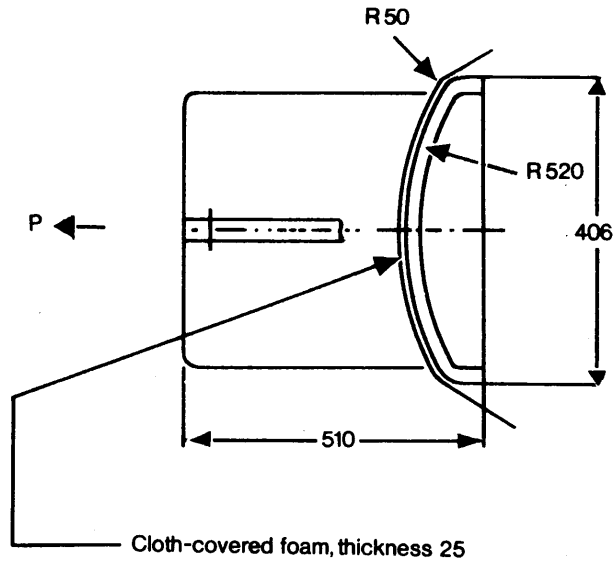

▼B

Figure 2

