

Council Directive of 22 July 1974 relating to motor vehicles with regard to the seats, their anchorages and head restraints (74/408/EEC) (repealed)

[^{F1}COUNCIL DIRECTIVE

of 22 July 1974

relating to motor vehicles with regard to the seats, their anchorages and head restraints
(74/408/EEC)] (repealed)

THE COUNCIL OF THE EUROPEAN COMMUNITIES,

Having regard to the Treaty establishing the European Economic Community, and in particular Article 100 thereof;

Having regard to the proposal from the Commission;

Having regard to the Opinion of the European Parliament⁽¹⁾;

Having regard to the Opinion of the Economic and Social Committee;

Whereas the technical requirements which motor vehicles must satisfy pursuant to national laws relate, *inter alia*, to interior fittings for the strength of seats and their anchorages;

Whereas these requirements differ from one Member State to another; whereas it is therefore necessary that all Member States adopt the same requirements either in addition to or in place of their existing regulations in order, in particular, to allow of the EEC type-approval procedure, which was the subject of Council Directive No 70/156/EEC⁽²⁾ of 6 February 1970 on the approximation of laws of the Member States relating to the type-approval of motor vehicles and their trailers, to be applied in respect of each type of vehicle;

Whereas common requirements for the interior fittings of the passenger compartment, the layout of the controls, the roof, the backrests and the rear part of the seats have been laid down by Council Directive No 74/60/EEC⁽³⁾ of 17 December 1973; whereas requirements for the internal fittings for the behaviour of the steering mechanism in the event of an impact have been laid down by Council Directive 74/297/EEC⁽⁴⁾ of 4 June 1974; whereas other requirements for the internal fittings, and in particular those relating to the head restraint, the seat belt anchorages and the layout of the controls, will be adopted at a later date;

Whereas it is appropriate to utilize basically certain technical requirements adopted by the UN Economic Commission for Europe in its Regulation No 17⁽⁵⁾ (Uniform provisions concerning the approval of vehicles with regard to the strength of the seats and of their anchorages) which is annexed to the Agreement of 20 March 1958 concerning the adoption of uniform conditions of approval and reciprocal recognition of approval for motor vehicle equipment and parts;

Whereas the approximation of national laws relating to motor vehicles entails mutual recognition by Member States of inspection carried out by each of them on the basis of common

Status: EU Directives are being published on this site to aid cross referencing from UK legislation. After IP completion day (31 December 2020 11pm) no further amendments will be applied to this version.

provisions; whereas such a system must, if it is to function smoothly, be applied by all Member States with effect from the same date,

HAS ADOPTED THIS DIRECTIVE:

Textual Amendments

- F1** Substituted by [Commission Directive 96/37/EC of 17 June 1996 adapting to technical progress Council Directive 74/408/EEC relating to the interior fittings of motor vehicles \(strength of seats and of their anchorages\)](#) (Text with EEA relevance).

Article 1

1 For the purposes of this Directive, ‘vehicle’ means any motor vehicle designed for use on the road, with or without bodywork, having at least four wheels and a maximum design speed exceeding 25 km/h,^[F1] with the exception of vehicles which run on rails and of agricultural and forestry tractors and all mobile machinery.]

[^{F2}Vehicles of category M₂ and M₃ shall be subdivided into classes as defined in section 2 of Annex I to Directive 2001/85/EC of the European Parliament and of the Council of 20 November 2001 relating to special provisions for vehicles used for the carriage of passengers comprising more than eight seats in addition to the driver's seat⁽⁶⁾.]

[^{F32} This Directive shall not apply to rearward-facing seats.]

Textual Amendments

- F1** Substituted by [Commission Directive 96/37/EC of 17 June 1996 adapting to technical progress Council Directive 74/408/EEC relating to the interior fittings of motor vehicles \(strength of seats and of their anchorages\)](#) (Text with EEA relevance).
- F2** Inserted by [Directive 2005/39/EC of the European Parliament and of the Council of 7 September 2005 amending Council Directive 74/408/EEC relating to motor vehicles with regard to the seats, their anchorages and head restraints](#) (Text with EEA relevance).
- F3** Substituted by [Directive 2005/39/EC of the European Parliament and of the Council of 7 September 2005 amending Council Directive 74/408/EEC relating to motor vehicles with regard to the seats, their anchorages and head restraints](#) (Text with EEA relevance).

Article 2

No Member State may refuse to grant EEC type-approval or national type-approval of a vehicle^[F1] on grounds relating to the strength of the seats or their anchorages, or to grant EEC type-approval or national type-approval of a seat on grounds relating to its strength and occupant protection capability, if these meet the requirements set out in Annexes II or III, as applicable, when the vehicle belongs to category M and is equipped with seat belts, and the requirements set out in Annex IV when the vehicle belongs to category M₂ or M₃ not equipped with seat belts or to category N. The vehicle categories are defined in Annex IIA to Directive 70/156/EEC.]

Status: EU Directives are being published on this site to aid cross referencing from UK legislation. After IP completion day (31 December 2020 11pm) no further amendments will be applied to this version.

Textual Amendments

- F1** Substituted by [Commission Directive 96/37/EC of 17 June 1996 adapting to technical progress Council Directive 74/408/EEC relating to the interior fittings of motor vehicles \(strength of seats and of their anchorages\)](#) (Text with EEA relevance).

Article 3

No Member State may refuse to register or prohibit the sale, entry into service or use of any vehicle^[F1] on grounds relating to the strength of the seats or their anchorages, or prohibit the sale, entry into service or use of any seat on grounds relating to its strength and occupant protection capability, if these meet the requirements of the relevant Annexes depending on the category to which the vehicle belongs as set out in Article 2.]

Textual Amendments

- F1** Substituted by [Commission Directive 96/37/EC of 17 June 1996 adapting to technical progress Council Directive 74/408/EEC relating to the interior fittings of motor vehicles \(strength of seats and of their anchorages\)](#) (Text with EEA relevance).

^[F2]Article 3a

1 The installation of side-facing seats shall be prohibited in vehicles of categories M₁, N₁, M₂ (of class III or B) and M₃ (of class III or B).

2 Paragraph 1 shall not apply to ambulances or to vehicles listed in the first indent of Article 8(1) of Directive 70/156/EEC.

3 Paragraph 1 shall further not apply to vehicles of category M₃ (of class III or B) of a technically permissible maximum laden mass exceeding 10 tonnes in which side-facing seats are grouped together at the rear of the vehicle to form an integrated saloon of up to 10 seats. Such side-facing seats shall be fitted with, at least, a head restraint and a two-point belt with retractor type-approved in accordance with Council Directive 77/541/EEC⁽⁷⁾. The anchorages for their safety belts shall comply with Council Directive 76/115/EEC⁽⁸⁾.

This exemption shall have effect for five years from 20 October 2005. It may be extended if reliable accident statistics are available and there has been further development of restraint systems.]

Textual Amendments

- F2** Inserted by [Directive 2005/39/EC of the European Parliament and of the Council of 7 September 2005 amending Council Directive 74/408/EEC relating to motor vehicles with regard to the seats, their anchorages and head restraints](#) (Text with EEA relevance).

Article 4

The Member State which has granted type-approval must take the necessary measures to ensure that it is informed of any modification of any part or characteristic referred to in ^[F1]Annex II, 2.2, Annex III, 2.3 or Annex III, 2.4, as applicable]. The competent authorities of that State shall determine whether fresh tests should be carried out on the modified vehicle and a fresh report drawn up. Where such tests reveal failure to comply with the requirements of this Directive, the modification shall not be approved.

Status: EU Directives are being published on this site to aid cross referencing from UK legislation. After IP completion day (31 December 2020 11pm) no further amendments will be applied to this version.

Textual Amendments

- F1** Substituted by [Commission Directive 96/37/EC of 17 June 1996 adapting to technical progress Council Directive 74/408/EEC relating to the interior fittings of motor vehicles \(strength of seats and of their anchorages\)](#) (Text with EEA relevance).

Article 5

Modifications which are necessary to adapt the provisions of [^{F1}the Annexes] to take account of technical progress shall be adopted in accordance with the procedure laid down in Article 13 of Directive No 70/156/EEC.

Textual Amendments

- F1** Substituted by [Commission Directive 96/37/EC of 17 June 1996 adapting to technical progress Council Directive 74/408/EEC relating to the interior fittings of motor vehicles \(strength of seats and of their anchorages\)](#) (Text with EEA relevance).

Article 6

1 By 1 March 1975, the Member States shall adopt and publish the provisions necessary to comply with this Directive and shall immediately inform the Commission thereof.

They shall apply these provisions from 1 October 1975.

2 As soon as this Directive has been notified, the Member States shall ensure that any draft laws, regulations or administrative provisions which they intend to adopt in the field covered by this Directive are communicated to the Commission in sufficient time for the latter to submit its comments thereon.

Article 7

This Directive is addressed to the Member States.

[^{F1}ANNEX I

ADMINISTRATIVE PROVISIONS FOR EEC TYPE-APPROVAL

1. Application for EEC vehicle type-approval
 - 1.1. The application for EEC type-approval of a vehicle of category M or N with regard to the seats, their seat anchorages and their head restraints, or of a vehicle of category M₂ or M₃ with regard to the anchorages, pursuant to Article 3 (4) of Directive 70/156/EEC shall be submitted by the vehicle manufacturer.
 - 1.2. A model for the information document is given in Appendix 1 to this Annex.
 - 1.3. The following must be submitted to the technical service responsible for conducting the type-approval tests:
 - 1.3.1. A vehicle representative of the type of vehicle to be approved and, if required, a relevant part of the vehicle structure;
 - 1.3.2. for vehicles covered by Annex II or III, an additional set of the seats of the type with which the vehicle is equipped, together with their anchorages;
 - 1.3.3. for vehicles in category M₁, in category M₂ with a maximum mass not exceeding 3 500 kg and in category N₁, with seats fitted or capable of being fitted with head restraints, in addition to the requirements set out in Paragraphs 1.3.1 and 1.3.2:
 - 1.3.3.1. in the case of detachable head restraints: an additional set of seats, fitted with head restraints, of the type with which the vehicle is equipped, together with their anchorages;
 - 1.3.3.2. in the case of separate head restraints: an additional set of the seats of the type with which the vehicle is equipped, with their anchorages, an additional set of the corresponding head restraints and the part of the vehicle structure to which the head restraint is fitted, or a complete structure.
2. Application for EEC component type-approval of a seat
 - 2.1. The application for EEC component type-approval of a seat type pursuant to Article 3 (4) of Directive 70/156/EEC shall be submitted by the seat manufacturer.
 - 2.2. [^{X1}A model for the information document is given in Appendix 3 to this Annex.]

Editorial Information

- X1** Substituted by [Corrigendum to Commission Directive 96/37/EC of 17 June 1996 adapting to technical progress Council Directive 74/408/EEC relating to the interior fittings of motor vehicles \(strength of seats and their anchorages\) \(Official Journal of the European Communities No L 186 of 27 July 1996\)](#).

- 2.3. The following must be submitted to the Technical Service responsible for conducting the type-approval tests:
 - 2.3.1. three samples of the seat of the type to be approved. Each seat must be clearly and indelibly marked with the manufacturers trade name or mark and the type-designation.
3. Granting of EEC type-approval

Status: EU Directives are being published on this site to aid cross referencing from UK legislation. After IP completion day (31 December 2020 11pm) no further amendments will be applied to this version.

- 3.1. If the relevant requirements are satisfied EEC type-approval pursuant to Article 4 (3) and, if applicable, Article 4 (4) of Directive 70/156/EEC shall be granted.
- 3.2. A model for the EEC-type approval certificate is given in:
 - 3.2.1. [^{X1}Appendix 2 for applications referred to in Paragraph 1;]
 - 3.2.2. Appendix 4 for applications referred to in Paragraph 2.
- 3.3. An approval number in accordance with Annex VII to Directive 70/156/EEC shall be assigned to each type of vehicle or each type of seat approved. The same Member State shall not assign the same number to another type of vehicle or to another type of seat.
4. Modifications of the type and amendments to approvals
 - 4.1. In the case of modifications of the type approved pursuant to this Directive, the provisions of Article 5 of Directive 70/156/EEC shall apply.
5. Conformity of production
 - 5.1. As a general rule, measures to ensure the conformity of production shall be taken in accordance with the provisions laid down in Article 10 of Directive 70/156/EEC.
6. Markings
 - 6.1. Every seat conforming to the type approved under this Directive as a component shall bear an EEC type-approval mark.
 - 6.2. This mark shall consist of:
 - 6.2.1. a rectangle surrounding the letter 'e' followed by the distinguishing number or letters of the Member State which has granted type-approval:

1	.	for Germany
2	.	for France
3	.	for Italy
4	.	for the Netherlands
5	.	for Sweden
6	.	for Belgium
[^{F47}	.	for Hungary
8	.	for the Czech Republic]
9	.	for Spain
11	.	for the United Kingdom
12	.	for Austria
13	.	for Luxembourg
17	.	for Finland
18	.	for Denmark
[^{F519}	.	for Romania]
[^{F420}	.	for Poland]
21	.	for Portugal
23	.	for Greece
[^{F426}	.	for Slovenia
27	.	for Slovakia
29	.	for Estonia
32	.	for Latvia
[^{F534}	.	for Bulgaria]

36	.	for Lithuania
CY	.	for Cyprus]
IRL	.	for Ireland ^[F6] .
^[F4] MT	.	for Malta.]

Textual Amendments

- F4** Inserted by Act concerning the conditions of accession of the Czech Republic, the Republic of Estonia, the Republic of Cyprus, the Republic of Latvia, the Republic of Lithuania, the Republic of Hungary, the Republic of Malta, the Republic of Poland, the Republic of Slovenia and the Slovak Republic and the adjustments to the Treaties on which the European Union is founded.
- F5** Inserted by Council Directive 2006/96/EC of 20 November 2006 adapting certain Directives in the field of free movement of goods, by reason of the accession of Bulgaria and Romania.
- F6** Deleted by Act concerning the conditions of accession of the Czech Republic, the Republic of Estonia, the Republic of Cyprus, the Republic of Latvia, the Republic of Lithuania, the Republic of Hungary, the Republic of Malta, the Republic of Poland, the Republic of Slovenia and the Slovak Republic and the adjustments to the Treaties on which the European Union is founded.

- 6.2.2. in the vicinity of the rectangle the ‘base approval number’ contained in Section 4 of the type-approval number referred to in Annex VII of Directive 70/156/EEC, preceded by the two figures indicating the sequence number assigned to the most recent major technical amendment to Directive 74/408/EEC on the date EEC type-approval was granted. In this Directive the sequence number is 00;
- 6.2.3. the additional symbol ‘D’ located above the rectangle indicating that the dynamic test(s) according to Appendix 1 of Annex III has (have) been carried out for the approval of the seat.
- 6.3. The EEC type-approval mark must be affixed to the seat or seats in such a way as to be indelible and clearly legible.
- 6.4. An example of the EEC type-approval mark is shown in Appendix 5.

Status: EU Directives are being published on this site to aid cross referencing from UK legislation. After IP completion day (31 December 2020 11pm) no further amendments will be applied to this version.

Appendix 1

Information document No ...

pursuant to Annex I of Directive 70/156/EEC⁽⁹⁾

relating to EEC type-approval of a vehicle with respect to its seats, anchorages and head restraints, Directive 74/408/EEC, as last amended by Directive 96/37/EC

The following information, if applicable must be supplied in triplicate and include a list of contents. Any drawings must be supplied in appropriate scale and in sufficient detail on size A4 or on a folder of A4 format. Photographs, if any, must show sufficient detail.

If the systems, components, or separate technical units have electronic controls, information concerning their performance must be supplied.

- 0. General
 - 0.1. Make (trade name of manufacturer):
 - 0.2. Type and general commercial description(s):
 - 0.3. Means of identification of type. If marked on the vehicle ^(b):
 - 0.3.1. Location of that marking:
 - 0.4. Category of vehicle ^(c):
 - 0.5. Name and address of manufacturer:
 - 0.8. Address(es) of assembly plant(s):
- 1. General construction characteristics of the vehicle
 - 1.1. Photographs and/or drawings of a representative vehicle:
 - 9. Bodywork
 - 9.1. Type of bodywork:
 - 9.2. Materials used and methods of construction:
 - 9.10. Interior fittings
 - 9.10.3. Seats
 - 9.10.3.1. Number:
 - 9.10.3.2. Position and arrangements:
 - 9.10.3.3. Mass:
 - 9.10.3.4. Characteristics: For seats not type approved as components, description and drawings of
 - 9.10.3.4.1. the seats and their anchorages:
 - 9.10.3.4.2. the adjustment system:

9.10.3.4.3 the displacement and locking systems:

9.10.3.4.4 the seat belt anchorages (if incorporated in the seat structure):

9.10.3.4.5 the parts of the vehicle used as anchorages:

9.10.3.5. Coordinates or drawing of the R point (x)

9.10.3.5.1 Driver's seat:

9.10.3.5.2 All other seating positions:

9.10.3.6. Design torso angle

9.10.3.6.1 Driver's seat:

9.10.3.6.2 All other seating positions:

9.10.3.7. Range of seat adjustment

9.10.3.7.1 Driver's seat:

9.10.3.7.2 All other seating positions:

9.10.4. Head restraints

9.10.4.1. Types(s) of head restraints: integrated/detachable/separate (¹)

9.10.4.2. Type-approval number(s), if available:

9.10.4.3. For head restraints not yet approved

9.10.4.3.1 A detailed description of the head restraint, specifying in particular the nature of the padding material or materials used and, where applicable, the position and specification of the braces and anchorage pieces for the type or types of seats for which approval is sought:

9.10.4.3.2 In the case of a 'separate' head restraint

9.10.4.3.2.1 A detailed description of the structural zone to which the head restraint is intended to be fixed:

9.10.4.3.2.2 Dimensional drawings of the characteristics parts of the structure and the head restraint:

Date, file

In the case of applications with respect to seats, their anchorages and, if applicable, their head restraints, all the items listed above except item 9.10.3.4.5 must be indicated.

In the case of applications with respect to seat anchorages of vehicles in category M₂ or M₃, items 0 to 0.8, 1, 1.1, 9 to 9.2, 9.10.3.4 and 9.10.3.4.5 must be indicated.

Status: EU Directives are being published on this site to aid cross referencing from UK legislation. After IP completion day (31 December 2020 11pm) no further amendments will be applied to this version.

Appendix 2

MODEL

(maximum format: A4 (210 × 297 mm))

EEC TYPE-APPROVAL CERTIFICATE

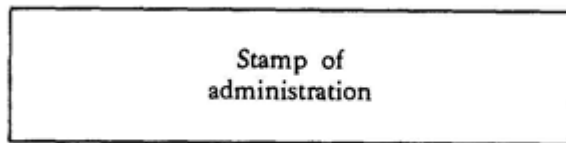

Communication concerning the

- type-approval⁽¹⁰⁾
- extension of type-approval⁽¹⁰⁾
- refusal of type-approval⁽¹⁰⁾
- withdrawal of type-approval⁽¹⁰⁾

of a type of vehicle/component/separate technical unit⁽¹⁰⁾ with regard to Directive 74/408/EEC, as last amended by Directive 96/37/EC.

Type-approval Number:

Reason for extension:

Section I

- 0.1. Make (trade name of manufacturer):
- 0.2. Type and general commercial description(s):
- 0.3. Means of identification of type, if marked on the vehicle/component/separate technical unit⁽¹⁰⁾⁽¹¹⁾:
 - 0.3.1. Location of that marking:
- 0.4. Category of vehicle⁽¹²⁾:
- 0.5. Name and address of manufacturer:
- 0.7. In the case of components and separate technical units, location and method of affixing of the EEC approval mark:
- 0.8. Address(es) of assembly plant(s):

Section II

1. Additional Information (where applicable) (see Addendum)

Status: EU Directives are being published on this site to aid cross referencing from UK legislation. After IP completion day (31 December 2020 11pm) no further amendments will be applied to this version.

2. Technical service responsible for carrying out the tests:
3. Date of test report:
4. Number of test report:
5. Remarks (if any) (see Addendum)
6. Place:
7. Date:
8. Signature:
9. The index to the information package lodged with the approval authority, which may be obtained on request, is attached.

Status: EU Directives are being published on this site to aid cross referencing from UK legislation. After IP completion day (31 December 2020 11pm) no further amendments will be applied to this version.

Addendum to EEC type-approval certificate No ...

concerning the type-approval of a vehicle with regard to
Directive 74/408/EEC as last amended by Directive 96/37/EC

1. Additional Information
 - 1.1. Make and type of EEC component type approved seats (if any):
 - 1.2. For each row of seats: individual/bench, fixed/adjustable, fixed back/adjustable back, tipping back/inclining back⁽¹³⁾.
 - 1.3. Position and arrangement of seats (EEC type-approved seats and other seats):
 - 1.4. Seats, if any, which incorporate a safety belt anchorage:
 - 1.5. For each seat: type of head restraints, if any integrated/detachable/separate⁽¹³⁾.
 - 1.6. Brief description of the vehicle type with respect to its seat anchorages and minimum value of the distance between anchorages (in the case of approvals granted with regard to seat anchorages of M₂ or M₃ vehicles):
5. Remarks:

Appendix 3

Information document No ...

relating to EEC type-approval of seats as components,

Directive 74/408/EEC, as last amended by Directive 96/37/EC

The following information, if applicable, must be supplied in triplicate and include a list of contents. Any drawings must be supplied in appropriate scale and in sufficient detail on size A4 or on a folder of A4 format. Photographs, if any, must show sufficient detail.

If the systems, components, or separate technical units have electronic controls, information concerning their performance must be supplied.

0. GENERAL
 - 0.1. Make (trade name of manufacturer):
 - 0.2. Type and general commercial description(s):
 - 0.5. Name and address of manufacturer:
 - 0.7. In the case of components and separate technical units, location and method of affixing of the EEC approval mark:
 - 0.8. Address(es) of assembly plant(s):
1. Description of the device
 - 1.1. Characteristics: Description and drawings of
 - 1.1.1. The seat and its attachment fittings:
 - 1.1.2. The adjustment system:
 - 1.1.3. The displacement and locking systems:
 - 1.1.4. The seat belt anchorages (if incorporated in the seat structure):
 - 1.1.5. Minimum distance between fitting points:
 - 1.1.6. Head restraints, if any:
 - 1.2. Co-ordinates or drawing of the R point (x):
 - 1.3. Range of seat adjustment:

Date, file

Status: EU Directives are being published on this site to aid cross referencing from UK legislation. After IP completion day (31 December 2020 11pm) no further amendments will be applied to this version.

Appendix 4

MODEL

(maximum format: A4 (210 × 297 mm))

EEC TYPE-APPROVAL CERTIFICATE

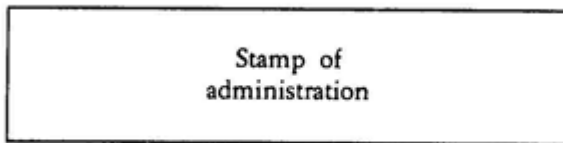

Communication concerning the

- type-approval⁽¹⁴⁾
- extension of type-approval⁽¹⁴⁾
- refusal of type-approval⁽¹⁴⁾
- withdrawal of type-approval⁽¹⁴⁾

of a type of vehicle/component/separate technical unit⁽¹⁴⁾ with regard to Directive 74/408/EEC, as last amended by Directive 96/37/EC.

Type-approval Number:

Reason for extension:

Section I

- 0.1. Make (trade name of manufacturer):
- 0.2. Type and general commercial description(s):
- 0.3. Means of identification of type, if marked on the vehicle/component/separate technical unit⁽¹⁴⁾⁽¹⁵⁾:
 - 0.3.1. Location of that marking:
- 0.4. Category of vehicle⁽¹⁶⁾:
- 0.5. Name and address of manufacturer:
- 0.7. In the case of components and separate technical units, location and method of affixing of the EEC type-approval mark:
- 0.8. Address(es) of assembly plant(s):

Status: EU Directives are being published on this site to aid cross referencing from UK legislation. After IP completion day (31 December 2020 11pm) no further amendments will be applied to this version.

Section II

1. Additional Information (where applicable) (see Addendum)
2. Technical service responsible for carrying out the tests:
3. Date of test report:
4. Number of test report:
5. Remarks (if any) (see Addendum)
6. Place:
7. Date:
8. Signature:
9. The index to the information package lodged with the approval authority, which may be obtained on request, is attached.

Status: EU Directives are being published on this site to aid cross referencing from UK legislation. After IP completion day (31 December 2020 11pm) no further amendments will be applied to this version.

Addendum to EEC type-approval certificate No ...

concerning the type-approval of a seat type as a component with regard to Directive 74/408/EEC, as last amended by Directive 96/37/EC

1. Additional Information
 - 1.1. Brief description of the seat type, its attachment fittings and its adjustment, displacement and locking system including the minimum distance between fitting points:
 - 1.3. Position and arrangement of seats:
 - 1.4. Seats, if any, which incorporate a safety belt anchorage:
 - 1.5. Type of head restraint, if any: integrated/detachable/separate⁽¹⁷⁾
5. Remarks:
 - 5.1. Energy absorption test of the rear part of the seat-back: yes/no⁽¹⁷⁾
 - 5.1.2. Drawings showing the area of the rear part of the seat-back verified for energy dissipation:
 - 5.2. Seat approved in accordance with Paragraph 3.2.1 of Annex III (dynamic test): yes/no⁽¹⁷⁾
 - 5.2.1. Test 1: yes/no⁽¹⁷⁾
 - 5.2.2. Test 2: yes/no⁽¹⁷⁾
 - 5.2.3. Description of the belts and anchorages used for the purpose of Test 2:
 - 5.2.4. Type of auxiliary seat used for Test 2 (if different from the type of seat approved):
 - 5.3. Seat approved in accordance with Paragraph 3.2.2 of Annex III (static test): yes/no⁽¹⁷⁾
 - 5.3.1. Test according to Appendix 5: yes/no⁽¹⁷⁾
 - 5.3.2. Test according to Appendix 6: yes/no⁽¹⁷⁾

Appendix 5

Model for the EEC type-approval mark

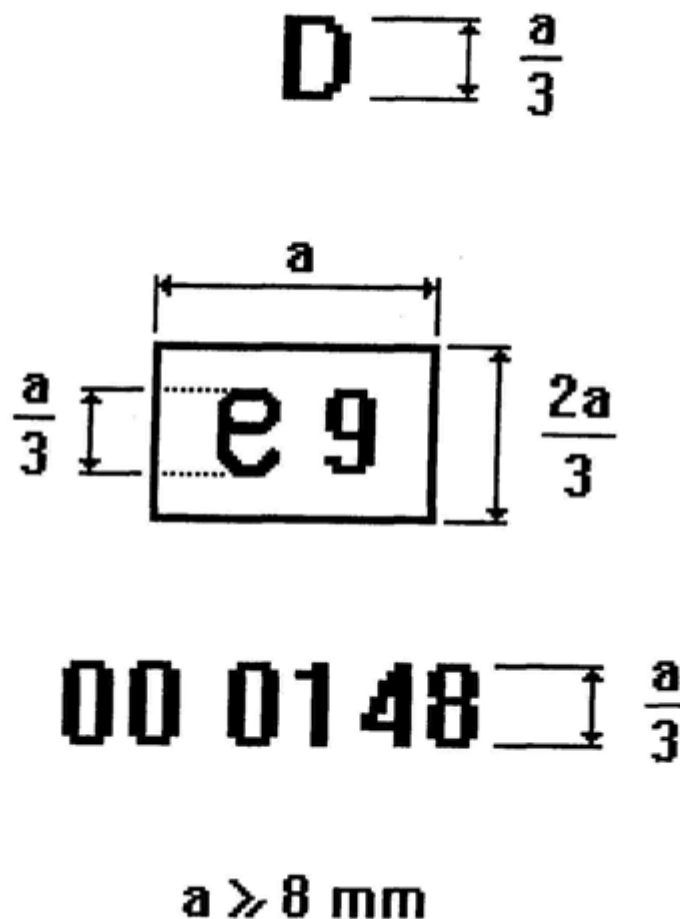

The seat bearing the above EEC type-approval mark is a device which has been approved in Spain (e9) under the base approval number 0148 on the basis of this Directive (00). The figures used are only indicative.]

[^{F1}ANNEX II

SCOPE, DEFINITIONS AND REQUIREMENTS FOR VEHICLES IN CATEGORY M1

1. Scope
 - 1.0. The requirements in this Annex apply to vehicles in categories M₁.

Status: EU Directives are being published on this site to aid cross referencing from UK legislation. After IP completion day (31 December 2020 11pm) no further amendments will be applied to this version.

- [^{F3}1.1. The requirements of this Annex do not apply to rearward-facing seats or to any head restraint fitted to such seats.]
- 1.2. Head restraints approved according to the requirements of Directive 78/392/EEC shall be deemed to conform with the applicable requirements of this Directive.
- 1.3. The rear parts of seats situated in Area 1, or the rear parts of head restraints which conform to the requirements of Paragraph 5.7 of Annex I to Directive 74/60/EEC (which relates to interior fittings), shall be deemed to conform to the corresponding requirements of this Directive.

2. Definitions

For the purposes of this Annex

- 2.1. 'Approval of a vehicle' means the approval of a vehicle type with regard to the strength of the seats and their anchorages, the design of the rear parts of the seat backs and the characteristics of the head restraints;
- 2.2. 'Vehicle type' means motor vehicles which do not differ essentially with respect to:
- 2.2.1. the structure, shape, dimensions, materials and the mass of the seats, although the seats may differ in covering and colour; differences not exceeding 5 % in the mass of the approved seat type shall not be considered significant;
- 2.2.2. the type and dimensions of the adjustment, displacement and locking systems of the seat back and seats and their parts;
- 2.2.3. the type and dimensions of the seat anchorages;
- 2.2.4. the dimensions, frame, materials and padding of head restraints, although they may differ in colour and covering;
- 2.2.5. the type and dimensions of the attachments of the head restraint and the characteristics of the part of the vehicle to which the head restraint is attached, in the case of a separate head restraint;
- [^{F3}2.3. 'Seat' means a structure which may or may not be integral with the vehicle structure, complete with trim, intended to seat one adult person. The term covers both an individual seat or part of a bench seat intended to seat one person.

Depending on its orientation, a seat is defined as follows:

- 2.3.1. 'Forward-facing seat' means a seat which can be used whilst the vehicle is in motion and which faces towards the front of the vehicle in such a manner that the vertical plane of symmetry of the seat forms an angle of less than + 10° or - 10° with the vertical plane of symmetry of the vehicle;
- 2.3.2. 'Rearward-facing seat' means a seat which can be used whilst the vehicle is in motion and which faces towards the rear of the vehicle in such a manner that the vertical plane of symmetry of the seat forms an angle of less than + 10° or - 10° with the vertical plane of symmetry of the vehicle;
- 2.3.3. 'Side-facing seat' means a seat which, with regard to its alignment with the vertical plane of symmetry of the vehicle, does not meet either of the definitions given in 2.3.1 or 2.3.2 above;]

- 2.4. 'Bench seat' means a structure complete with trim, intended to seat more than one adult person;
- 2.5. 'Anchorage' means the system by which the seat assembly is secured to the vehicle structure, including the affected parts of the vehicle structure;
- 2.6. 'Adjustment system' means the device by which the seat or its parts can be adjusted to a position suited to the morphology of the seated occupant. This device may, in particular, permit:
- 2.6.1. longitudinal adjustment;
- 2.6.2. vertical adjustment;
- 2.6.3. angular adjustment;
- 2.7. 'Displacement system' means a device by which the seat or one of its parts can be displaced or rotated, without a fixed intermediate position, to permit easy access to the space behind the seat concerned;
- 2.8. 'Locking system' means a device ensuring that the seat and its parts are maintained in the position of use;
- F⁷2.9.

Textual Amendments

- F7** Deleted by [Directive 2005/39/EC of the European Parliament and of the Council of 7 September 2005 amending Council Directive 74/408/EEC relating to motor vehicles with regard to the seats, their anchorages and head restraints \(Text with EEA relevance\)](#).

- 2.10. 'Transverse plane' means a vertical plane perpendicular to the median longitudinal plane of the vehicle;
- 2.1. 'Longitudinal plane' means a plane parallel to the median longitudinal plane of the vehicle;
- 2.12. 'Head restraint' means a device whose function is to limit the rearward displacement of an adult occupant's head in relation to his torso in order to reduce the danger of injury to the cervical vertebrae of that occupant in the event of an accident;
- 2.12.1. 'Integrated head restraint' means a head restraint formed by the upper part of the seat back. Head restraints meeting the definitions in paragraphs 2.12.2 and 2.12.3 below, but which can only be detached from the seat or the vehicle structure by the use of tools or by the partial or complete removal of the seat covering, meet the present definition;
- 2.12.2. 'Detachable head restraint' means a head restraint consisting of a component separable from the seat, designed for insertion and positive retention in the seat back structure;
- 2.12.3. '[^{X1}Separate head restraint' means a head restraint consisting of a component separate from the seat, designed for insertion and/or positive retention in the structure of the vehicle;]
- 2.13. 'R point' means the seating reference point as defined in Annex III to Directive 77/649/EEC;

Status: EU Directives are being published on this site to aid cross referencing from UK legislation. After IP completion day (31 December 2020 11pm) no further amendments will be applied to this version.

- 2.14. 'Reference line' means the line on the manikin reproduced in Figure 1.
3. Requirements
- 3.1. A head restraint shall be mounted on every outboard front seat in every vehicle of category M₁. (Seats fitted with head restraints, intended for fitment in other seating positions and in other categories of vehicle, may also be approved to this Annex).
- 3.2. General requirements applicable to all seats
- 3.2.1. Every adjustment and displacement system provided shall incorporate a locking system, which shall operate automatically. Locking systems for armrests or other comfort devices are not necessary unless the presence of such devices will cause additional risk of injury to the occupants of a vehicle in the event of a collision.
- 3.2.2. The unlocking control for a device as referred to in Paragraph 2.7 shall be placed on the outside of the seat close to the door. It shall be easily accessible, even to the occupant of the seat immediately behind the seat concerned.
- 3.2.3. The rear parts of seats situated in Area 1, defined in Paragraph 8.1.1 of Appendix 1, shall pass the energy dissipation test in accordance with the requirements of Appendix 2⁽¹⁸⁾.
- 3.2.3.1. This requirement is deemed to be met if, in the tests carried out by the procedure specified in Appendix 2, the deceleration of the headform does not exceed 80g continuously for more than 3 ms. Moreover, no dangerous edge shall occur during or remain after the test.
- 3.2.3.2. This requirements of paragraph 3.2.3 shall not apply to rearmost seats or to back-to-back seats.
- 3.2.4. The surface of the rear parts of seats shall exhibit no dangerous roughness or sharp edges likely to increase the risk of severity of injury to the occupants⁽¹⁸⁾. This requirement is considered as satisfied if the surface of the rear parts of seats tested in the conditions specified in Appendix 1 exhibit radii of curvature of not less than:
- 2,5 mm in area 1,
 - 5,0 mm in area 2,
 - 3,2 mm in area 3.
- These areas are defined in Paragraph 8.1 of Appendix 1.
- 3.2.4.1. This requirement does not apply to:
- the parts of the different areas exhibiting a projection of less than 3.2 mm from the surrounding surface, which shall exhibit blunted edges, provided that the height of the projection is not more than half its width,
 - rearmost seats and back-to-back seats,
 - rear parts of seats situated below a horizontal plane passing through the lowest R point in each row of seats. (Where rows of seats have different heights, starting from the rear, the plane shall be turned up or down forming a vertical step passing through the R point of the row of seats immediately in front),
 - parts such as 'flexible wire mesh'.
- 3.2.4.2. In Area 2, defined in Paragraph 8.1.2 of Appendix 1, surfaces may exhibit radii less than 5 mm, but not less than 2.5 mm provided that they pass the energy-dissipation test

- prescribed in Appendix 2. Moreover, these surfaces must be padded to avoid direct contact of the head with the seat frame structure.
- 3.2.4.3. If the areas above contain parts covered with material softer than Shore 50 hardness, the above requirements, with the exception of those relating to the energy-dissipation test in accordance with the requirements of Appendix 2, shall apply only to the rigid parts.
- 3.2.5. No failure shall be shown in the seat frame or in the seat anchorage, the adjustment and displacement systems or their locking devices during or after the test prescribed in Paragraphs 2 and 3 of Appendix 1. Permanent deformations, including ruptures, may be accepted provided that these do not increase the risk of injury in the event of a collision and the prescribed loads were sustained.
- 3.2.6. No release of the locking systems shall occur during the tests described in Paragraph 3 of Appendix 1.
- 3.2.7. After the tests, the displacement systems intended for permitting or facilitating the access of occupants must be in working order; they must be capable, at least once, of being unlocked and must permit the displacement of the seat or the part of the seat for which they are intended.
- 3.2.8. Any other displacement systems, as well as adjustment systems and their locking systems are not required to be in working order.
- 3.2.9. In the case of seats provided with head restraints, the strength of the seat back and of its locking devices is deemed to meet the requirements set out in Paragraph 2 when, after testing in accordance with Paragraph 4.3.6, no breakage of the seat or seat back has occurred; otherwise, it must be shown that the seat is capable of meeting the requirements set out in Paragraph 2.
- 3.2.10. In the case of seats (benches) with more places to sit than head restraints, the test described in Paragraph 2 shall be carried out.
- 3.3. Special requirements for seats fitted or capable of being fitted with head restraints.
- 3.3.1. The presence of the head restraint must not be an additional cause of danger to the occupants of the vehicle. In particular, it shall not in any position of use exhibit any dangerous roughness or sharp edge liable to increase the risk or seriousness of injury to the occupants.
- 3.3.2. Parts of the front and rear faces of the head restraints situated in Area 1, as defined in Paragraph 8.1.1.3 of Appendix 1, shall pass the energy absorption test.
- 3.3.2.1. This requirement is deemed to be met if in the tests carried out by the procedure specified in Appendix 2 the deceleration of the headform does not exceed 80g continuously for more than 3 ms. Moreover, no dangerous edge shall occur during or remain after the test.
- 3.3.3. Parts of the front and rear faces of head restraints situated in Area 2, as defined in Paragraph 8.1.2 of Appendix 1, shall be so padded as to prevent any direct contact of the head with the components of the structure and shall meet the requirements of Paragraph 3.2.4 applicable to the rear parts of seats situated in Area 2.
- 3.3.4. The requirements of Paragraphs 3.3.2 and 3.3.3 shall not apply to parts of rear faces of head restraints designed to be fitted to seats behind which no seat is provided.

Status: EU Directives are being published on this site to aid cross referencing from UK legislation. After IP completion day (31 December 2020 11pm) no further amendments will be applied to this version.

- 3.3.5. The head restraint shall be secured to the seat or to the vehicle structure in such a way that no rigid and dangerous parts project from the padding of the head restraint or from its attachment to the seat back as a result of the pressure exerted by the head form during the test.
- 3.3.6. In the case of a seat fitted with a head restraint, the provisions of Paragraph 3.2.3 may, after agreement of the technical service, be considered to be met if the seat fitted with its head restraint complies with the provisions of Paragraph 3.3.2.
- 3.4. Height of head restraints
- 3.4.1. The height of head restraints shall be measured as described in Paragraph 5 of Appendix 1.
- 3.4.2. For head restraints not adjustable for height, the height shall be not less than 800 mm⁽¹⁹⁾ for front seats and not less than 750 mm⁽²⁰⁾ for other seating positions.
- 3.4.3. For head restraints adjustable for height:
- 3.4.3.1. the height shall be not less than 800 mm⁽¹⁹⁾ for front seats and not less than 750 mm⁽²⁰⁾ for other seating positions; this value shall be obtained in a position between the highest and lowest positions to which adjustment is possible;
- 3.4.3.2. there shall be no use position resulting in a height of less than 750 mm⁽²⁰⁾;
- 3.4.3.3. in the case of seats other than the front seats the head restraints may be such that they can be displaced to a position resulting in a height of less than 750 mm⁽²⁰⁾, provided that such position is clearly recognisable to the occupant as not being intended for the use of the head restraint;
- 3.4.3.4. in the case of front seats head restraints may be such that they can be automatically displaced when the seat is not occupied, to a position resulting in a height of less than 750 mm⁽²⁰⁾, provided that they automatically return to the position of use when the seat is occupied.
- 3.4.4. The dimensions mentioned in paragraphs 3.4.2 and 3.4.3.1 above may be reduced to leave adequate clearance between the head restraint and the interior surface of the roof, the windows or any part of the vehicle structure; however, the clearance shall not exceed 25 mm. In the case of seats fitted with displacement and/or adjustment systems, this shall apply to all seat positions. Furthermore, by way of derogation from paragraph 3.4.3.2, there shall not be any use position resulting in a height lower than 700 mm.
- 3.4.5. By derogation to the height requirements mentioned in Paragraphs 3.4.2, 3.4.3.1 and 3.4.3.2, the height of any head restraint designed to be provided in rear centre seats or seating positions shall be not less than 700 mm.
- 3.5. In the case of a seat capable of being fitted with a head restraint, the provisions of Paragraphs 3.2.3 and 3.3.2 shall be verified.
- 3.5.1. The height of the part of the device on which the head rests, measured as described in Paragraph 5 of Appendix 1, shall in the case of a head restraint adjustable for height be not less than 100 mm.
- 3.6. There shall be no gap of more than 60 mm between the seat back and the head restraint in the case of a device not adjustable for height. If the head restraint is adjustable for

height it shall, in its lowest position, be not more than 25 mm from the top of the seat back. In the case of seats or bench seats adjustable in height provided with separate head restraints, this requirement shall be verified for all the positions of the seat or bench seat.

- 3.7. In the case of head restraints integral with the seat back, the area to be considered is:
- above a plane perpendicular to the reference line at 540 mm from the R point;
 - between two vertical longitudinal planes passing at 85 mm on either side of the reference line. In this area, one or more gaps which regardless of their shape can show a distance ‘a’ of more than 60 mm when measured as described in Paragraph 7 of Appendix 1, are permitted, provided that, after the additional test under Paragraph 4.3.3.2 of Appendix 1, the requirements of Paragraph 3.10 are still met.
- 3.8. In the case of head restraints adjustable for height one or more gaps, which regardless of their shape can show a distance ‘a’ of more than 60 mm when measured as described in Paragraph 7 of Appendix 1, are permitted on the part of the device serving as a head restraint provided that, after the additional test under Paragraph 4.3.3.2 of Appendix 1, the requirements of Paragraph 3.10 are still met.
- 3.9. The width of the head restraint shall be such as to provide appropriate support for the head of a person normally seated. As determined according to the procedure described in Paragraph 6 of Appendix 1, the head restraint shall cover an area extending not less than 85 mm to each side of the vertical median plane of the seat for which the head restraint is intended.
- 3.10. The head restraint and its anchorage shall be such that the maximum backward displacement X of the head permitted by the head restraint and measured in conformity with the static procedure laid down in Paragraph 4.3 of Appendix 1, is less than 102 mm.
- 3.11. The head restraint and its anchorage shall be strong enough to bear without breakage the load specified in Paragraph 4.3.6 of Appendix 1. In the case of head restraints integral with the seatback, the requirements of this paragraph shall apply to the parts of the seat back structure situated above a plane perpendicular to the reference line at 540 mm from the R point.
- 3.12. If the head restraint is adjustable, it shall not be possible to raise it beyond the maximum operational height except by deliberate action on the part of the user distinct from any act necessary for its adjustment.
- 3.13. The strength of the seat back and of its locking devices is deemed to meet the requirements set out in Paragraph 2 of Appendix 1 when, after testing in accordance with Paragraph 4.3.6 of Appendix 1 no breakage of the seat or seat back has occurred; otherwise, it shall be shown that the seat is capable of meeting the test requirements set out in Paragraph 2 of Appendix 1.

Appendix 1

Tests and instructions for use

1. General specifications applicable to all tests
 - 1.1. The seat back, if adjustable, shall be locked in a position corresponding to a rearward inclination as close as possible to 25° from the vertical of the torso reference line of the manikin shown in Figure 1, unless otherwise specified by the manufacturer.
 - 1.2. When a seat, its locking mechanism and its installation are identical or symmetrical with respect to another seat on the vehicle, the technical service may test only one such seat.
 - 1.3. [^{XI}In the case of seats with adjustable head restraints, the tests shall be conducted with the head restraints placed in the most unfavourable position (generally the highest position) allowed by its adjusting system.]
2. Test of strength of the seat back and its adjustment systems
 - 2.1. A force producing a moment of 530 Nm in relation to the R point shall be applied longitudinally and rearwards to the upper part of the seat back frame through a component stimulating the back of the manikin. In the case of a bench seat, where part or all of the supporting frame (including that of the head restraints) is common to more than one seating position, the test shall be conducted simultaneously for all those seating positions.
3. Test of the strength of the seat anchorage and the adjustment, locking and displacement systems
 - 3.1. [^{XI}A longitudinal horizontal deceleration of not less than 20g shall be applied for 30 ms in the forward direction to the whole shell, or a representative part of the shell, of the vehicle, in accordance with the requirements of Paragraph 1 of Appendix 3.]
 - 3.2. A longitudinal deceleration in accordance with the requirements of Paragraph 3.1 shall be applied in the rearward direction.
 - 3.3. The requirements of Paragraphs 3.1 and 3.2 shall be verified for all positions of the seat. In the case of seats fitted with an adjustable head restraint, the test shall be conducted with the head restraints placed in the most unfavourable position (generally the highest position) allowed by its adjusting system. During the test the seat shall be so positioned that no external factor shall prevent the release of the locking systems.

These conditions shall be considered to be met if the seat is tested after being adjusted in the following positions:

- the longitudinal adjustment is fixed one notch or 10 mm rearward of the most forward normal driving position or position of use as indicated by the manufacturer (for seats with independent vertical adjustment, the cushion shall be placed in its highest position);
- the longitudinal adjustment is fixed one notch or 10 mm forward of the most rearward normal driving position or position of use as indicated by the manufacturer (for seats with independent vertical adjustment, the cushion shall be placed in its lowest position), and where appropriate, in accordance with the requirements of Paragraph 3.4.

- 3.4. In cases where the arrangement of the locking systems is such that, in a seat position other than those defined in Paragraph 3.3, the distribution of the forces on the locking devices and seat anchorages would be less favourable than with either configuration defined in Paragraph 3.3, the tests shall be conducted for that less favourable seating position.
- 3.5. The test conditions of paragraph 3.1 shall be considered to be satisfied if, at the request of the manufacturer, they are replaced by a collision test of the complete vehicle in running order against a rigid barrier as laid down in paragraph 2 of Appendix 3 to this Annex. In this case, the seat shall be adjusted for the least favourable conditions of distribution of stresses in the anchorage system as provided for in paragraphs 1.1, 3.3 and 3.4.
4. Test of the performance of the head restraint
- 4.1. If the head restraint is adjustable, it shall be placed in the most unfavourable position (generally the highest position) allowed by its adjustment system.
- 4.2. In the case of a bench seat, where part or all of the supporting frame (including that of the head restraints) is common to more than one seating position, the test shall be conducted simultaneously for all those seating positions.
- 4.3. Test
- 4.3.1. All lines, including the projections of the reference line, shall be drawn in the vertical median plane of the seat or seating position concerned (see Figure 2).
- 4.3.2. The displaced reference line is determined by applying to the part simulating the back of the manikin referred to in Figure 2 an initial force producing a rearward moment of 373 Nm about the R point.
- 4.3.3. By means of a spherical headform 165 mm in diameter an initial force producing a moment of 373 Nm about the R point is applied at right angles to the displaced reference line at a distance of 65 mm below the top of the head restraint, the reference line being kept in its displaced position as determined in accordance with the requirements of Paragraph 4.3.2.
- 4.3.3.1. If the presence of gaps prevents the application of the force prescribed in Paragraph 4.3.3 at 65 mm from the top of the head restraint, the distance may be reduced so that the axis of the force passes through the centre line of the frame element nearest to the gap.
- 4.3.3.2. In the case described in paragraphs 3.7 and 3.8 of Annex II, the test shall be repeated by applying to each gap, using a sphere of 165 mm in diameter, a force:
- passing through the centre of gravity of the smallest of the sections of the gap, along transversal planes parallel to the reference line,
- and
- reproducing a moment of 373 Nm about the R point.
- 4.3.4. The tangent Y to the spherical headform, parallel to the displaced reference line, is determined.
- 4.3.5. The distance X provided for in Paragraph 3.10 of Annex II, between the tangent Y and the displaced reference line is measured.

Status: EU Directives are being published on this site to aid cross referencing from UK legislation. After IP completion day (31 December 2020 11pm) no further amendments will be applied to this version.

4.3.6. To check the effectiveness of the head restraint, the initial load specified in Paragraphs 4.3.3 and 4.3.3.2 is increased to 890 N unless the breakage of the seat or seat back occurs earlier.

5. Determination of the height of the head restraint

5.1. All lines, including the projection of the reference line, shall be drawn in the vertical median plane of the seat or seating position concerned, the intersection of such plane with the seat determining the contour of the head restraint and of the seat back (see Figure 1a).

5.2. The manikin described in Annex III to Directive 77/649/EEC shall be placed in a normal position on the seat.

5.3. The projection of the reference line of the manikin is then, in the seat concerned, drawn in the plane specified in Paragraph 4.3.1.

The tangent S to the top of the head restraint is drawn perpendicular to the reference line.

5.4. The distance 'h' from the R point to the tangent S is the height to be taken into consideration in implementing the requirements of Paragraph 3.4 of Annex II.

6. Determination of the width of the head restraint (see Figure 1b)

6.1. The plane S₁, perpendicular to the reference line and situated 65 mm below the tangent S defined in Paragraph 5.3, determines a section in the head restraint bounded by the outline C.

6.2. The width of the head restraint to be taken into consideration in implementing the requirements of Paragraph 3.9 of Annex II is the distance 'L' measured in the plan S₁ between the vertical longitudinal planes p and p'.

6.3. The width of the head restraint shall if necessary also be determined in the plane perpendicular to the reference line 635 mm above the R point of the seat, this distance being measured along the reference line.

7. Determination of distance 'a' of head restraint gaps (see Figure 3)

7.1. The distance 'a' shall be determined for each gap and in relation to the front face of head restraint, by means of a sphere having a diameter of 165 mm.

7.2. The sphere shall be put into contact with the gap in a point of the gap area which allows the maximum sphere intrusion, considering no load is to be applied.

7.3. [^{X1}The distance between the two points of contact of the sphere with the gap will constitute the distance 'a' to be considered for the evaluation of the provisions under Paragraphs 3.7 and 3.8 of Annex II.]

8. Tests for checking energy dissipation on the seat back and head restraint

8.1. The surfaces of the rear parts of seats to be checked are those situated in the areas defined below which can be contacted by a 165 mm diameter sphere when the seat is mounted in the vehicle.

8.1.1. Area 1

8.1.1.1. In the case of separate seats without head restraints, this area shall include the rear part of the seat back between the longitudinal vertical planes situated at 100 mm on either

side of the longitudinal median plane of each designated outboard seating position defined by the manufacturer and above a plane perpendicular to the reference line 100 mm below the top of the seat back.

8.1.1.2. In the case of bench seats without head restraints, this area shall extend between the longitudinal vertical planes situated at 100 mm on either side of the longitudinal median plane of each designated outboard seating position defined by the manufacturer and above a plane perpendicular to the reference line 100 mm below the top of the seat-back.

8.1.1.3. In the case of seats or bench seats with head restraints, this area shall extend between the longitudinal vertical planes, on either side of, and 70 mm from the longitudinal median plane of the seat or of the seating position concerned and situated above the plane perpendicular to the reference line 635 mm from the R point. For the test, the head restraint, if adjustable, shall be placed in the most unfavourable position (generally the highest) permitted by its adjustment system.

8.1.2. Area 2

8.1.2.1. In the case of seats or bench seats without head restraints and seats or bench seats with detachable or separate head restraints, Area 2 shall extend above a plane perpendicular to the reference line 100 mm distant from the top of the seat back, other than parts of Area 1.

8.1.2.2. In the case of seats or bench seats with integrated head restraints, Area 2 shall extend above a plane perpendicular to the reference line 440 mm distant from the R point of the seat or of the seating position concerned, other than parts of Area 1.

8.1.3. Area 3

8.1.3.1. Area 3 is defined as the part of the back of the seat or the bench seats situated above the horizontal planes defined in the third indent of Paragraph 3.2.4.1 of this Annex, excluding parts situated in Area 1 and Area 2.

9. Equivalent test methods

If a test method other than those specified in Paragraphs 2, 3, 4 above and Appendix 2 is used, its equivalence shall be proved.

INSTRUCTIONS FOR USE

For seats fitted with adjustable head restraints, the manufacturers shall provide instructions on how to operate, adjust, lock and, where appropriate, remove the head restraints.

Status: EU Directives are being published on this site to aid cross referencing from UK legislation. After IP completion day (31 December 2020 11pm) no further amendments will be applied to this version.

Appendix 2

Test procedure for checking energy dissipation

1. Installation, test apparatus, recording instruments and procedure
 - 1.1. Setting up
 - 1.1.1. The seat, as mounted in the vehicle, shall be firmly secured to the test bench with the attachment parts provided by the manufacturer, so as to remain stationary when the impact is applied.
 - 1.1.2. The seat-back, if adjustable, shall be locked in the position specified in Paragraph 1.1 of Appendix 1.
 - 1.1.3. If the seat is fitted with a head restraint, the head restraint shall be mounted on the seat-back as in the vehicle. Where the head restraint is separate, it shall be secured to the part of the vehicle structure to which it is normally attached.
 - 1.1.4. If the head restraint is adjustable it shall be placed in the most unfavourable position the adjustment device permits.
 - 1.2. Test apparatus
 - 1.2.1. This apparatus consists of a pendulum whose pivot is supported by ball-bearings and whose reduced mass⁽²¹⁾ at its centre of percussion is 6,8 kg. The lower extremity of the pendulum consists of a rigid headform 165 mm in diameter whose centre is identical with the centre of percussion of the pendulum.
 - 1.2.2. The headform shall be fitted with two accelerometers and a speed-measuring device, all capable of measuring values in the direction of impact.
 - 1.3. Recording instruments

The recording instruments used shall be such that measurements can be made with the following degrees of accuracy:

1.3.1. Acceleration

accuracy: $\pm 5\%$ of the actual value

frequency class of data channel: class 600 corresponding to ISO standard 6487 (1987);

cross-axis sensitivity: $\leq 5\%$ of the lowest point on the scale.

1.3.2. Speed

accuracy: $\pm 2,5\%$ of the real value;

sensitivity: 0,5 km/h

1.3.3. Time recording

the instrumentation shall enable the action to be recorded throughout its duration and readings to be made within one-thousandth of a second;

the beginning of the impact at the moment of first contact between the headform and the item being tested shall be detected on the recordings used for analysing the test.

1.4. Test procedure

1.4.1. Tests on the seat back

With the seat installed as indicated in Paragraph 1.1 of this Appendix, the direction of impact from the rear towards the front shall be situated in a longitudinal plane at an angle of 45° from the vertical.

The impact points shall be selected by the test laboratory in Area 1 as defined in Paragraph 8.1.2 of Appendix 1, or if necessary in Area 2 as defined in Paragraph 8.1.2 of Appendix 1, on surfaces exhibiting radii of curvature less than 5 mm.

1.4.2. Tests on the head restraint

The head restraint shall be fitted and adjusted as indicated in Paragraph 1.1 of this Appendix. Impacts shall be performed on points selected by the test laboratory in Area 1 as defined in Paragraph 8.1.1 of Appendix 1, and possibly in Area 2 as defined in Paragraph 8.1.2 of Appendix 1, on surfaces exhibiting radii of curvature less than 5 mm.

1.4.2.1. For the rear face, the direction of impact from the rear towards the front shall be in a longitudinal plane at an angle of 45° from the vertical.

1.4.2.2. For the front face, the direction of impact from the front towards the rear shall be horizontal in a longitudinal plane.

1.4.2.3. The front and rear zones are respectively bounded by the horizontal plane tangential to the top of the head restraint as determined in Paragraph 5 of Appendix 1.

1.4.3. The headform shall strike the test item at a speed of 24,1 km/h; this speed shall be achieved either by the mere energy of propulsion or by using an additional impelling device.

2. Results

The deceleration rate shall be taken as the average of the readings on the two decelerometers.

3. Equivalent procedures

(see Paragraph 9 of Appendix 1 of this Annex).

Status: EU Directives are being published on this site to aid cross referencing from UK legislation. After IP completion day (31 December 2020 11pm) no further amendments will be applied to this version.

Appendix 3

Method for testing the strength of seat anchorages and their adjustment, locking and displacement systems

1. Test of resistance to inertia effects
 - 1.1. The seats to be tested shall be mounted on the vehicle body for which they are designed. This vehicle body shall be firmly anchored on a test trolley as prescribed in the following paragraphs.
 - 1.2. The method used for anchoring the vehicle body on the test trolley shall not result in a reinforcement of the seat anchorages.
 - 1.3. The seats and their parts shall be adjusted and locked as prescribed in Paragraph 1.1 and in one of the positions described in Paragraph 3.3 or 3.4 or Appendix 1 of this Annex.
 - 1.4. If the seats of a group do not present essential differences in the sense of Paragraph 2.2 of this Annex, the tests prescribed in Paragraphs 3.1 and 3.2 of Appendix 1 may be carried out with one seat adjusted to its foremost position and the other set adjusted to its rearmost position.
 - 1.5. The trolley deceleration is measured with data channels of frequency class (CFC) 60 corresponding to the characteristics of international Standard ISO 6487 (1980).
2. Collision test of the complete vehicle against a rigid barrier
 - 2.1. The barrier shall consist of a block of reinforced concrete of not less than 3 m width, not less than 1.5 m in height and not less than 0.6 m in thickness. The front face shall be perpendicular to the final part of the run-up track and shall be covered with plywood boards 19 ± 1 mm thick. At least 90 tonnes of earth shall be compressed behind the block of reinforced concrete. The barrier of reinforced concrete and earth may be replaced by obstacles having the same front surface, provided, that they give equivalent results.
 - 2.2. At the moment of impact the vehicle shall run free. It shall reach the obstacle on a course perpendicular to the collision wall; the maximum lateral misalignment allowed between the vertical median line of the front of the vehicle and the vertical median line of the collision wall shall be ± 30 cm; at the moment of impact the vehicle shall no longer be subjected to the action of any additional steering or propelling device. The speed on impact shall be between 48.3 km/h and 53.1 km/h.
 - 2.3. The fuel feed system shall be filled with water to a mass equal to 90 % of a full tank as specified by the manufacturer.
 - 2.3.1. All other systems (brake, cooling, etc.) may be empty; in this case the mass of the liquids shall be offset.

Figure 1a

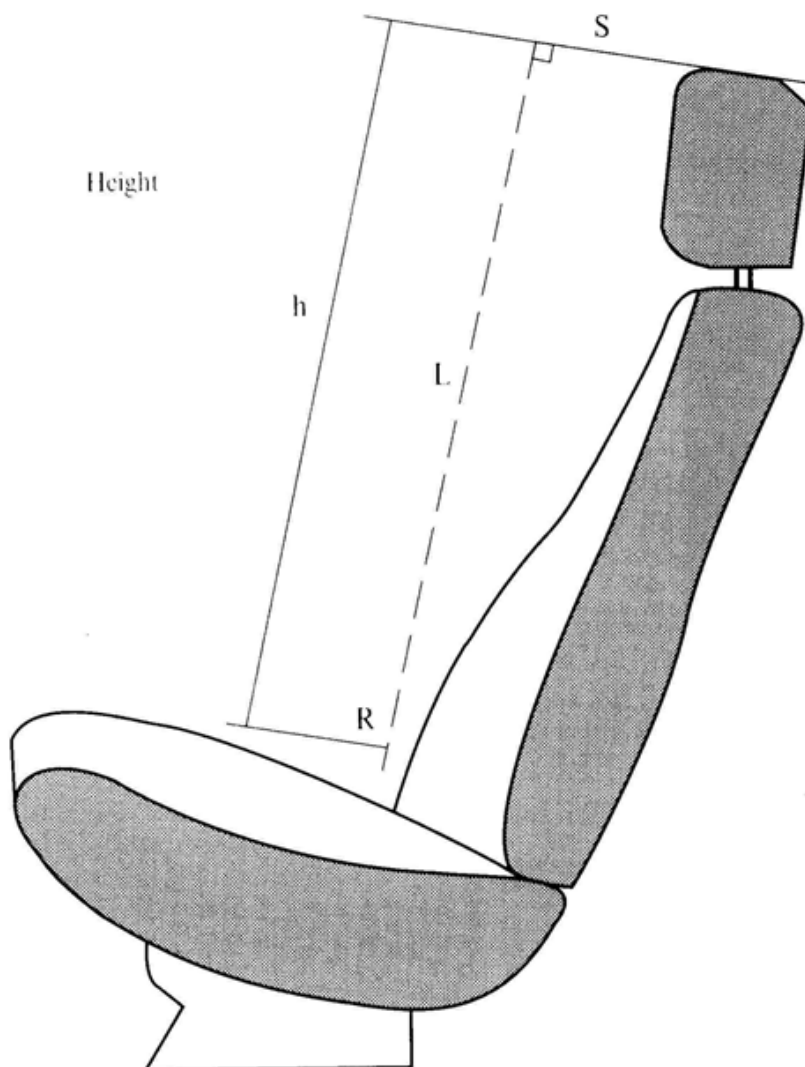

Figure 1b

Status: EU Directives are being published on this site to aid cross referencing from UK legislation. After IP completion day (31 December 2020 11pm) no further amendments will be applied to this version.

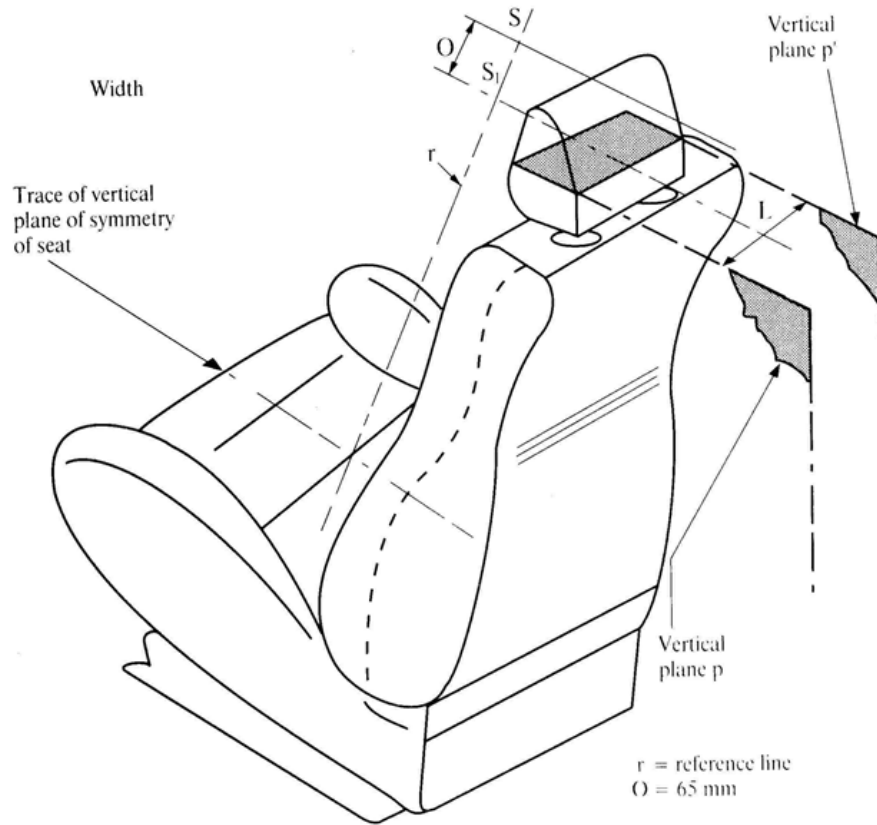
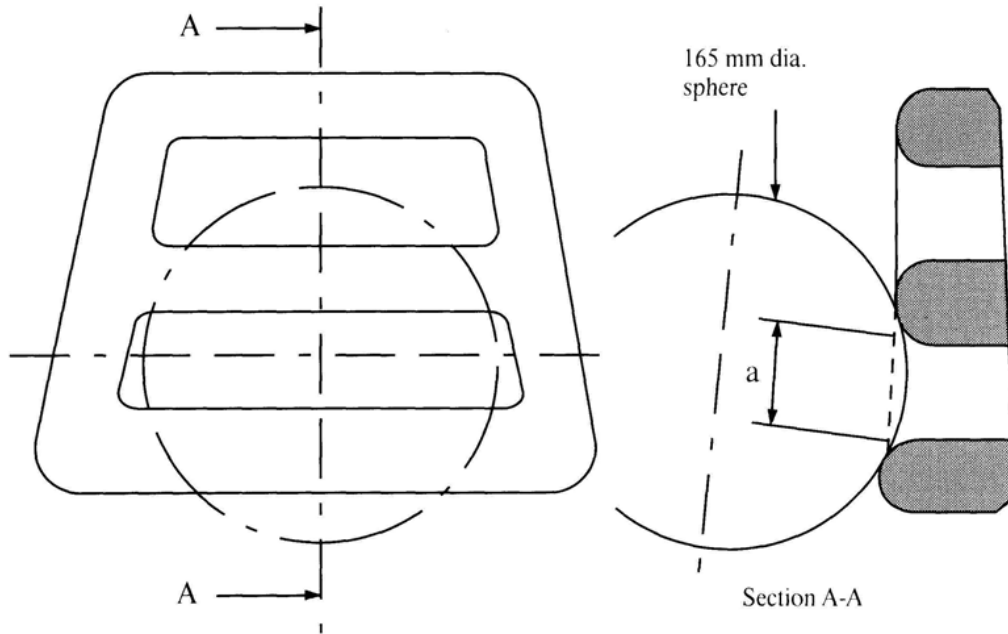
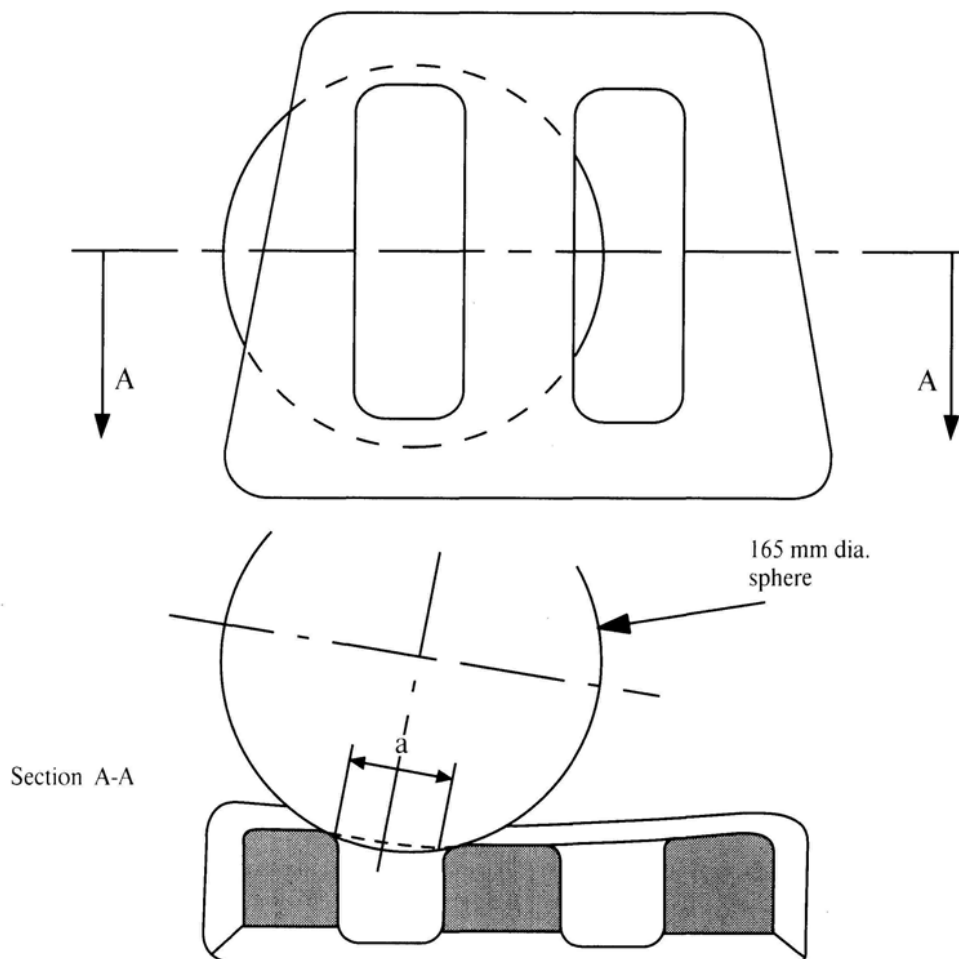

Figure 2

Status: EU Directives are being published on this site to aid cross referencing from UK legislation. After IP completion day (31 December 2020 11pm) no further amendments will be applied to this version.



Note: Section A-A is to be made in a point of the gap area which allows the maximum sphere intrusion without exerting any load.



Note: Section A-A is to be made in a point of the gap area which allows the maximum sphere intrusion without exerting any load.]

[^{F1}ANNEX III

SCOPE, DEFINITIONS AND REQUIREMENTS FOR CERTAIN VEHICLES IN CATEGORIES M₂ AND M₃

1. Scope
 - 1.1. This Annex applies to seats in vehicles in categories M₂ and M₃, except vehicles in these categories which are designed for both urban use and standing passengers, in respect of:
 - 1.1.1. Every passenger seat intended to be installed facing forwards;

Status: EU Directives are being published on this site to aid cross referencing from UK legislation. After IP completion day (31 December 2020 11pm) no further amendments will be applied to this version.

- 1.1.2. The seat anchorages provided in the vehicle and intended to be fitted with the seats indicated in Paragraph 1.1 or any other type of seat likely to be fitted on these anchorages.
- 1.2. M₂ vehicles may be approved to Annex II as an alternative to this Annex.
- 1.3. Vehicles where some seats benefit from the derogation provided in Item 5.5.4 of Annex I to Directive 76/115/EEC shall be approved to this Annex.
- 1.4. The tests described in this Annex may also be applied to other vehicle parts (including rear facing seats), as referred to in Paragraph 3.1.10 of Annex I to Directive 77/541/EEC and Paragraph 4.3.7 of Annex I to Directive 76/115/EEC.

2. Definitions

For the purposes of this Annex:

- 2.1. ‘Approval of a seat’ means an approval of a seat type as a component in relation to the protection of the occupants of forward-facing seats with regard to their strength and the design of the seat backs;
- 2.2. ‘Approval of a vehicle’ means an approval of a vehicle type with regard to the strength of the parts of the vehicle structure to which seats are to be secured, and with regard to the installation of seats;
- 2.3. ‘Seat type’ means seats which do not differ essentially with respect to the following characteristics likely to affect their strength and their aggressiveness:
 - 2.3.1. Structure, shape, dimensions and materials of the load bearing parts;
 - 2.3.2. Types and dimensions of the seat back adjustment and locking system;
 - 2.3.3. Dimensions, structure and materials of the attachments and supports (e. g. legs);
- 2.4. ‘Vehicle type’ means vehicles which do not differ essentially in respect of:
 - the constructional features relevant to this Directive; and,
 - the type or types of EC component type approved seat(s) fitted to the vehicle, if any.
- [^{F3}2.5. ‘Seat’ means a structure likely to be anchored to the vehicle structure, including its trim and attachment fittings, intended to be used in a vehicle and to seat one or more adult persons.

Depending on its orientation, a seat is defined as follows:

- 2.5.1. ‘Forward-facing seat’ means a seat which can be used whilst the vehicle is in motion and which faces towards the front of the vehicle in such a manner that the vertical plane of symmetry of the seat forms an angle of less than + 10° or - 10° with the vertical plane of symmetry of the vehicle;
- 2.5.2. ‘Rearward-facing seat’ means a seat which can be used whilst the vehicle is in motion and which faces towards the rear of the vehicle in such a manner that the vertical plane of symmetry of the seat forms an angle of less than + 10° or - 10° with the vertical plane of symmetry of the vehicle;
- 2.5.3. ‘Side-facing seat’ means a seat which, with regard to its alignment with the vertical plane of symmetry of the vehicle, does not meet either of the definitions given in 2.5.1 or 2.5.2 above;]

- 2.6. 'Individual seat' means a seat designed and constructed for the accommodation of one seated passenger;
- 2.7. 'Double seat' means a seat designed and constructed for the accommodation of two seated passengers side by side; two seats side by side and having no interconnection shall be regarded as two individual seats;
- 2.8. 'Row of seats' means a seat designed and constructed for the accommodation of three or more seated passengers side by side; several individual or double seats arranged side by side shall not be regarded as a row of seats;
- 2.9. 'Seat cushion' means the part of the seat which is arranged almost horizontally and designed to support a seated passenger;
- 2.10. 'Seat-back' means the part of the seat that is almost vertical, designed to support the passenger's back, shoulders and, possibly, his head;
- 2.11. 'Adjustment system' means the device by which the seat or its parts can be adjusted to a position suited to the seated occupant;
- 2.12. 'Displacement system' means a device enabling the angle of the seat or one of its parts to be displaced laterally or longitudinally without a fixed intermediate position of the seat or one of its parts, to facilitate access by passengers;
- 2.13. 'Locking system' means a device ensuring that the seat and its parts are maintained in the position of use;
- 2.14. 'Anchorage' means a part of the floor or of the body of a vehicle to which a seat may be fixed;
- 2.15. 'Attachment fittings' means bolts or other components used to attach the seat to the vehicle;
- 2.16. 'Trolley' means the test equipment made and used for dynamic reproduction of road accidents involving frontal collision;
- 2.17. 'Auxiliary seat' means a seat for the manikin mounted on the trolley to the rear of the seat to be tested. This seat shall be representative of the seat to be used in the vehicle behind the seat to be tested;
- 2.18. 'Reference plane' means the plane passing through the points of contact of the heels of the manikin, used for the determination of the H-point and the actual angle of torso for the seating position of motor vehicles;
- 2.19. 'Reference height' means the height of the top of the seat above the reference plane;
- 2.20. 'Manikin', a manikin corresponding to the specifications for Hybrid II or III⁽²²⁾.
- 2.21. 'Reference zone' means the space between two vertical longitudinal planes, 400 mm apart and symmetrical with respect to the H-point, and defined by rotation of the apparatus, described in Annex II of Directive 74/60/EEC, from vertical to horizontal. The apparatus shall be positioned as described in that Annex and set to the maximum length of 840 mm.
- 2.22. 'Three-point belt' for the purposes of this Directive also includes belts with more than three anchorage points.

Status: EU Directives are being published on this site to aid cross referencing from UK legislation. After IP completion day (31 December 2020 11pm) no further amendments will be applied to this version.

- 2.23. 'Seat pitch' means the horizontal distance between successive seats measured from the front of the seat back on one to the rear of the seat back of the seat in front, at a height of 620 mm above the floor.
3. Requirements for seats
- 3.1. Each type of seat shall be subject to the test requirements of either Appendix 1 (dynamic test) or Appendices 5 and 6 (static test) at the request of the manufacturer.
- 3.2. The tests which the seat type has passed shall be recorded in the Addendum to the Approval Certificate (Appendix 4 of Annex 1).
- 3.3. Every adjustment and displacement system provided shall incorporate a locking system, which shall operate automatically.
- 3.4. The adjustment and locking systems shall not be required to be in full working order after the test.
- 3.5. A head restraint shall be mounted on every outboard front seat in every vehicle of category M₂ with a maximum mass not exceeding 3 500 kg; head restraints mounted in such vehicles shall comply with the requirements of this Annex or Directive 78/932/EEC.
4. Requirements for seat anchorages of a vehicle type
- 4.1. The anchorages for the seats on the vehicle shall be capable of withstanding:
- 4.1.1. either the test described in Appendix 2;
- 4.1.2. or, if a seat is mounted on the part of the vehicle structure being tested, the tests prescribed in Appendix 1. The seat need not be an approved seat provided that it satisfies the requirements of Paragraph 3.2.1 of the above mentioned Appendix.
- 4.2. Permanent deformation, including breakage, of an anchorage or the surrounding area shall be permissible provided the prescribed force has been sustained throughout the prescribed period.
- 4.3. When there is more than one type of anchorage on a vehicle, each variant shall be tested in order to obtain approval for the vehicle.
- 4.4. One test may be used to approve simultaneously a seat and a vehicle.
- 4.5. [^{X1}In the case of vehicles of category M₃, seat anchorages shall be deemed to comply with the requirements of Paragraphs 4.1 and 4.2 if the safety belt anchorages of the corresponding seating positions are fitted directly to the seats to be installed and these belt anchorages comply with the requirements of Directive 76/115/EEC, if necessary with the derogation provided in Item 5.5.4 of Annex I thereof.]
5. Requirements for installation of seats in a vehicle type
- 5.1. All forward-facing seats installed shall be approved to the requirements of Paragraph 3 of this Annex and subject to the following conditions:
- 5.1.1. the seat shall have a reference height of at least 1 m; and
- 5.1.2. the H-point of the seat immediately behind shall be less than 72 mm higher than the H-point of the seat in question or, if the seat behind is more than 72 mm higher, the seat shall be tested and approved for installation in such a position.

- 5.2. When approved to Appendix 1, Tests 1 and 2 shall apply except as follows:
 - 5.2.1. [^{X1}Test 1 shall not apply where the rear of the seat cannot be struck by an unrestrained passenger (i.e. there is no forward-facing seat directly behind the seat to be tested)].
 - 5.2.2. Test 2 shall not apply
 - 5.2.2.1. if the rear of the seat cannot be struck by a restrained passenger; or
 - 5.2.2.2. if the seat behind is fitted with a three-point belt with anchorages that comply fully with Directive 76/115/EEC (without derogation); or
 - 5.2.2.3. if the seat fulfils the requirements of Appendix 6 of this Annex.
- 5.3. When approved to Appendices 5 and 6, all tests shall apply except as follows:
 - 5.3.1. The test of Appendix 5 shall not apply if the rear of the seat cannot be struck by an unrestrained passenger (i. e. there is no forward-facing seat directly behind the seat to be tested).
 - 5.3.2. The test of Appendix 6 shall not apply
 - 5.3.2.1. if the rear of the seat cannot be struck by a restrained passenger; or
 - 5.3.2.2. if the seat behind is fitted with a three-point belt with anchorages that comply fully with Directive 76/115/EEC (without derogation).

Appendix 1

test procedures for seats according to Paragraph 3 and/or anchorages according to paragraph 4.1.2

1. Requirements
 - 1.1. The tests are to determine:
 - 1.1.1. If the seat occupant(s) is (are) correctly retained by the seat(s) in front of him (them) and/or by the use of a safety belt.
 - 1.1.1.1. This requirement shall be considered satisfied if the forward movement of any part of the trunk and the head of the manikin does not pass beyond the transversal vertical plane situated at 1.6 m from the R point of the auxiliary seat;
 - 1.1.2. If the seat occupant(s) is (are) not seriously injured.
 - 1.1.2.1. This requirement shall be considered satisfied if the following biomechanical acceptability criteria for the instrumented manikin, determined in accordance with Appendix 4, are met; that is:
 - 1.1.2.1.1. the head acceptability criterion HAC is less than 500;
 - 1.1.2.1.2. the thorax acceptability criterion (ThAC) is less than 30 g except for periods totalling less than 3 ms ($g = 9,81 \text{ m/s}^2$);
 - 1.1.2.1.3. the femur acceptability criterion (FAC) is less than 10 kN and the value of 8 kN is not exceeded for periods totalling more than 20 ms.
 - 1.1.3. The seat and the seat mountings are strong enough. This requirement shall be considered satisfied if:
 - 1.1.3.1. no part of the seat, the seat mountings or the accessories becomes completely detached during the test;
 - 1.1.3.2. the seat remains firmly held, even if one or more anchorages is partly detached, and all the locking systems remain locked during the whole duration of the test;
 - 1.1.3.3. after the test no structural part of the seat or accessories has any fracture or sharp or pointed edges or corners likely to cause any bodily injury.
 - 1.2. All fittings forming part of the back of the seat or accessories thereto shall be such as to be unlikely to cause any bodily injury to a passenger during impact. This requirement shall be considered satisfied if any part contactable by a sphere 165 mm in diameter presents a radius of curvature of at least 5 mm.
 - 1.2.1. If any part of the fittings and accessories referred to above is made of a material of hardness less than 50 shore A on a rigid backing, the requirements set out in paragraph 3.3 shall apply only to the rigid backing.
 - 1.2.2. The parts of the back of the seat such as adjustment devices for the seat and accessories shall not be subject to any requirements of paragraph 3.3 if in the position of rest they are situated below a horizontal plane 400 mm above the reference plane, even if the occupant might enter into contact with them.
2. Preparation of the seat to be tested

- 2.1. The seat to be tested shall be mounted:
 - 2.1.1. either on a testing platform representative of the body of a vehicle,
 - 2.1.2. or on a rigid testing platform.
- 2.2. The anchorage on the testing platform provided for the test seat(s) shall be identical to or have the same characteristics as that used in vehicle(s) in which the seat is intended to be used.
- 2.3. The seat to be tested shall be complete with all upholstery and accessories. If the seat is fitted with a table, it shall be in the stowed position.
- 2.4. If adjustable laterally, the seat shall be positioned for maximum extension.
- 2.5. If adjustable, the seat back shall be adjusted so that the resulting inclination of the torso of the manikin used for determining the H-point and the actual torso angle for seating positions in motor vehicles is as close as possible to that recommended by the manufacturer for normal use or, in the absence of any particular recommendation by the manufacturer, as near as possible to 25° towards the rear in relation to the vertical.
- 2.6. If the seat back is equipped with a head restraint adjustable for height, it shall be in its lowest position.
- 2.7. Seat belts of an approved type, conforming to Directive 77/541/EEC and mounted on anchorages installed according to Directive 76/115/EEC shall be fitted to both the auxiliary seat and the seat to be tested.

3. Dynamic tests

3.0. Test 1

- 3.1. The testing platform shall be mounted on a trolley.

3.2. Auxiliary seat

The auxiliary seat may be the same type as the seat being tested and shall be located parallel to and directly behind the seat being tested, the two seats being at the same height, adjusted identically and on a pitch of 750 mm.

- 3.2.1. If an auxiliary seat of a different type is used this shall be mentioned in the Addendum to the type-approval certificate (Appendix 4 to Annex I).

3.3. Manikin

A manikin shall be installed behind each seating position of the seat to be tested as follows:

- 3.3.1. The manikin shall be placed unrestrained on the auxiliary seat so that its plane of symmetry corresponds to the plane of symmetry of the seating position in question.
- 3.3.2. The manikin's hands shall rest on their thighs with their elbows touching the seat back; the legs shall be extended to the maximum and shall, if possible, be parallel; the heels shall touch the floor.
- 3.3.3. Each manikin required shall be installed on a seat in accordance with the following procedure:
 - 3.3.3.1. the manikin shall be placed on the seat as close as possible to the desired position.

Status: EU Directives are being published on this site to aid cross referencing from UK legislation. After IP completion day (31 December 2020 11pm) no further amendments will be applied to this version.

- 3.3.3.2. a flat rigid surface 76 mm × 76 mm in area shall be placed as low as possible against the front of the manikin's torso.
 - 3.3.3.3. the flat surface shall be pressed horizontally against the manikin's torso at a load of between 25 and 35 daN:
 - 3.3.3.3.1. the torso shall be drawn forward by the shoulders to the vertical position, then laid back against the seat back. This operation shall be performed twice;
 - 3.3.3.3.2. without the torso moving, the head shall be placed in a position such that the platform supporting the measuring instruments contained in the head is horizontal and that the median sagittal plan of the head is parallel to that of the vehicle.
 - 3.3.3.4. the flat surface shall be carefully removed,
 - 3.3.3.5. the manikin shall be moved forward on the seat and the installation procedure described above repeated,
 - 3.3.3.6. if necessary, the position of the lower members shall be corrected,
 - 3.3.3.7. the measuring instruments installed shall not in any way affect the movement of the manikin during impact,
 - 3.3.3.8. the temperature of the system of measuring instruments shall be stabilised before the test and maintained so far as possible within a range between 19 and 26 °C.
- 3.4. Impact simulation
- 3.4.1. The impact speed of the trolley shall be between 30 and 32 km/h.
 - 3.4.2. The deceleration of the trolley during the impact test shall be in accordance with the provisions shown in Figure 1 below. Except for intervals totalling less than 3 ms, the deceleration time history of the trolley shall remain between the limit curves shown in Figure 1.
 - 3.4.3. Furthermore, the average deceleration shall be comprised between 6,5 and 8,5 g.
- 3.5. Test 2
- 3.5.1. Test 1 shall be repeated with a manikin seated in the auxiliary seat; the manikin shall be restrained by a safety belt fitted and adjusted in accordance with the manufacturers instructions. The number of seat belt anchorage points for the purpose of Test 2 shall be recorded in the addendum to the type-approval certificate for the seat (Appendix 4 of Annex 1 refers).
 - 3.5.2. The auxiliary seat shall be either of the same type as the seat being tested or of a different type, the details of which shall be recorded in the Addendum to the Type-Approval Certificate (Appendix 4 of Annex I).
 - 3.5.3. Test 2 may also be applied to vehicle parts other than a seat, as referred to Paragraph 3.1.10 of Directive 77/541/EEC and Paragraph 4.3.7 of Directive 76/115/EEC.
 - 3.5.4. In the case where Test 2 is conducted with the manikin restrained by a 3-point belt and the injury criteria are not exceeded, the auxiliary seat shall be considered to have met the requirements relating to the static test loads and movement of the upper anchorage during the test specified in Directive 76/115/EEC with regard to this installation.

Figure 1

Status: EU Directives are being published on this site to aid cross referencing from UK legislation. After IP completion day (31 December 2020 11pm) no further amendments will be applied to this version.

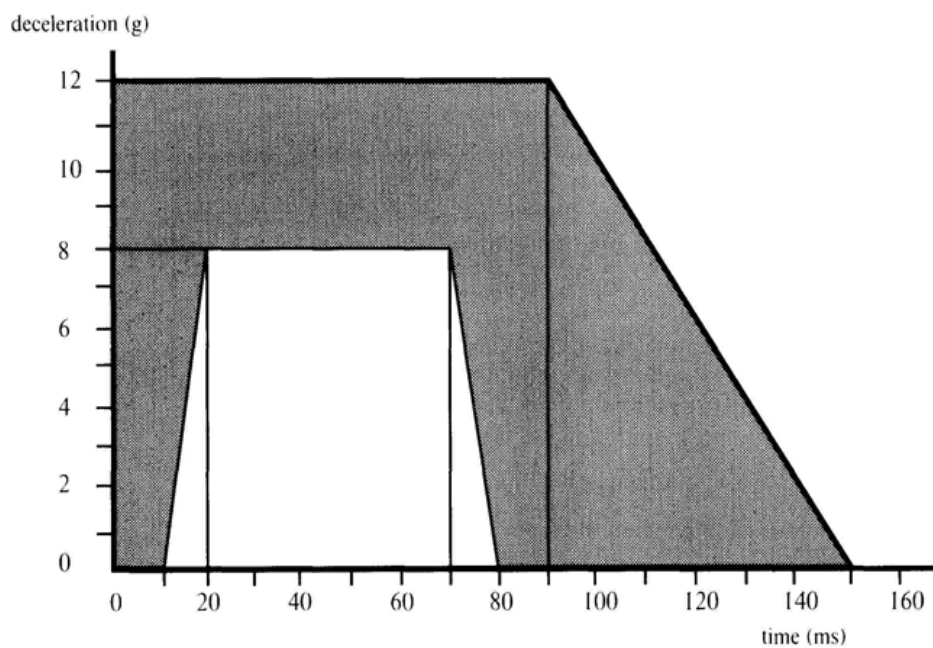

Status: EU Directives are being published on this site to aid cross referencing from UK legislation. After IP completion day (31 December 2020 11pm) no further amendments will be applied to this version.

Appendix 2

Test procedure for the anchorages of a vehicle in application of Paragraph 4.1.1

1. Test apparatus
 - 1.1. A rigid structure sufficiently representative of the seat intended for use on the vehicle is fixed by the means of fixation (bolts, screws, ect.) provided by the manufacturer.
 - 1.2. If several seat types differing from one another in respect of the distance between the front and back ends of their feet can be mounted on the same anchorage, the test shall be carried out with the shortest footing. This footing shall be described on the type-approval certificate.
2. Test procedure
 - 2.1. A force F shall be applied:
 - 2.1.1. at a height of 750 mm above the reference plane and on the vertical line containing the geometrical centre of the surface bounded by the polygon having the different anchorage points as apexes or, if applicable, the extreme anchorages of the seat, by the rigid structure as defined in Paragraph 1.1,
 - 2.1.2. in the horizontal direction and directed to the front of the vehicle,
 - 2.1.3. in a delay as short as possible and for a duration of at least 0.2 s.
 - 2.2. The force F shall be determined either
 - 2.2.1. by the following formula: $F = (5\ 000 \pm 50) \times i$

where: F is given in N and i represents the number of seating positions of the seat for which the anchorages to be tested are to be approved; or, if requested by the manufacturer,
 - 2.2.2. in accordance with the representative loads measured during dynamic tests as described in Appendix 1.

Appendix 3

Measurements to be made

1. All measurements necessary shall be made with measurement systems corresponding to the specifications of International Standard ISO 6487 entitled 'Technique of measurement in impact tests: Instrumentation' and published in 1987.

2. Dynamic test

2.1. Measurements to be made on the trolley

The characteristics of the deceleration of the trolley shall be measured, from the accelerations measured on the rigid frame of the trolley, with measurement systems with a CFC of 60.

2.2. Measurements to be made on manikins

The readings of the measuring devices shall be recorded through independent data channels of the following CFC:

2.2.1. Measurements in the head of the manikin

The resultant triaxial acceleration referring to the centre of gravity (γ_r)⁽²³⁾ shall be measured with a CFC of 600.

2.2.2. Measurements in the thorax of the manikin

The resultant acceleration at the centre of gravity shall be measured with a CFC of 180.

2.2.3. Measurements in the femur of the manikin

The axial compression force shall be measured with a CFC of 600.

Status: EU Directives are being published on this site to aid cross referencing from UK legislation. After IP completion day (31 December 2020 11pm) no further amendments will be applied to this version.

Appendix 4

Determination of acceptability criteria

1. Head acceptability criterion (HAC)

- 1.1. This acceptability criterion (HAC) is calculated on the basis of the resultant triaxial acceleration measured according to Appendix 3, Paragraph 2.2.1 by the following expression:

$$\text{HAC} = (t_2 - t_1) \left[\frac{1}{t_2 - t_1} \int_{t_1}^{t_2} \gamma_r dt \right]^{2.5}$$

in which t_1 and t_2 are any values of time during the test, HAC being maximum value for and interval t_1 and t_2 . The value of t_1 and t_2 are expressed in seconds.

2. Thorax acceptability criterion (ThAC)

- 2.1. This criterion is determined by the absolute value of the resultant acceleration, expressed in g and measured according to Appendix 3, Paragraph 2.2.2, and by the acceleration period, expressed in ms.

3. Femur acceptability criterion (FAC)

This criterion is determined by the compression load expressed in kN, transmitted axially on each femur of the manikin and measured according to Appendix 3, Paragraph 2.2.3, and by the duration of the compression load, expressed in ms.

Appendix 5

Statistic test requirements and procedure

1. Requirements
 - 1.1. The requirements for seats tested according to this Appendix are to determine:
 - 1.1.1. If the seat occupants are correctly retained by the seats in front of them;
 - 1.1.2. If the seat occupants are not seriously injured; and
 - 1.1.3. If the seat and the seat mountings are strong enough.
 - 1.2. The requirements of Paragraph 1.1.1 shall be considered satisfied if the maximum displacement of the central point of application of each force prescribed in Paragraph 2.2.1 measured in the horizontal plane and in the longitudinal median plane of the relevant seating position does not exceed 400 mm.
 - 1.3. The requirements of Paragraph 1.1.2 shall be considered satisfied if the following characteristics are met:
 - 1.3.1. The maximum displacement of the central point of application of each of the forces prescribed in paragraph 2.2.1, measured as described in Paragraph 1.2, is not less than 100 mm.
 - 1.3.2. The maximum displacement of the central point of application of each of the forces prescribed in Paragraph 2.2.2, measured as described in Paragraph 1.2, is not less than 50 mm.
 - 1.3.3. All fittings forming part of the back of the seat of accessories thereto shall be such as to be unlikely to cause any bodily injury to a passenger during impact. This requirement shall be considered satisfied if any part contactable by a sphere 165 mm in diameter presents a radius of curvature of at least 5 mm.
 - 1.3.4. If any part of the fittings and accessories referred to above is made of a material of hardness less than 50 shore A on a rigid backing, the requirements set out in Paragraph 1.3.3 shall apply only to the rigid backing.
 - 1.3.5. The parts of the back of the seat such as adjustment devices for the seat and accessories shall not be subject to any requirements of Paragraph 1.3.3 if in the position of rest they are situated below a horizontal plane 400 mm above the reference plane, even if the occupant might enter into contact with them.
 - 1.4. The requirements of Paragraphs 1.1.3 shall be considered satisfied if:
 - 1.4.1. No part of the seat, the seat mountings or the accessories becomes completely detached during the test;
 - 1.4.2. The seat remains firmly held, even if one or more anchorages is partly detached, and all the locking systems remain locked during the whole duration of the test;
 - 1.4.3. After the test no structural part of the seat or accessories has any fracture or sharp or pointed edges or corners likely to cause any bodily injury.
2. Static tests

Status: EU Directives are being published on this site to aid cross referencing from UK legislation. After IP completion day (31 December 2020 11pm) no further amendments will be applied to this version.

2.1. Test apparatus

2.1.1. This consists of cylindrical surfaces with a radius of curvature equal to 82 (± 3 mm) and a width:

2.1.1.1. at least equal to the width of the seat-back of each seating position of the seat to be tested for the upper form,

2.1.1.2. equal to 320 (- 0 + 10 mm) for the lower form as shown in Figure 1 of this Appendix.

2.1.2. The surface resting against the parts of the seat shall be made of a material the hardness of which is not less than 80 Shore A.

2.1.3. Each cylindrical surface shall be equipped with at least one force transducer able to measure the forces applied in the direction defined in Paragraph 2.2.1.1.

2.2. Test procedure

2.2.1. A test force to

$$\frac{1\ 000}{H} 1 \pm 50\ \text{N}$$

shall be applied using a device, conforming to Paragraph 2.1, to the rear part of the seat corresponding to each seating position of the seat.

2.2.1.1. The direction of application of the force shall be situated in the vertical median plane of the seating position concerned; it shall be horizontal and from the rear towards the front of the seat.

2.2.1.2. This direction shall be situated at the height H_1 which shall be between 0,70 m and 0,80 m and above the reference plane. The exact height shall be determined by the manufacturer.

2.2.2. A test force equal to

$$\frac{2\ 000}{H} 2 \pm 100\ \text{N}$$

shall be applied simultaneously to the rear part of the seat corresponding to each seating position of the seat in the same vertical plane and in the same direction at the height H_2 which shall be between 0,45 and 0,55 m above the reference plane, with a device conforming to Paragraph 2.1. The exact height shall be determined by the manufacturer.

2.2.3. The test forms shall be maintained as far as possible in contact with the rear of the seat during the application of the forces specified in Paragraphs 2.2.1 and 2.2.2. They shall be able to pivot in a horizontal plane.

2.2.4. Where a seat consists of more than one seating position the forces corresponding to each seating position shall be applied simultaneously and there shall be as many upper and lower forms as seating positions.

2.2.5. The initial position of each seating position of each of the forms shall be determined by bringing the test devices into contact with the seat with a force equal to at least 20 N.

2.2.6. The forces indicated in Paragraph 2.2.1 and 2.2.2 shall be applied as rapidly as possible and shall be maintained together at the specified value, whatever the deformation, for at least 0,2 seconds.

2.2.7. If the test has been carried out with one or more forces but not with all the forces greater than those specified in Paragraphs 2.2.1 and 2.2.2 and if the seat complies with the requirements, the test shall be considered to be satisfied.

Figure 1

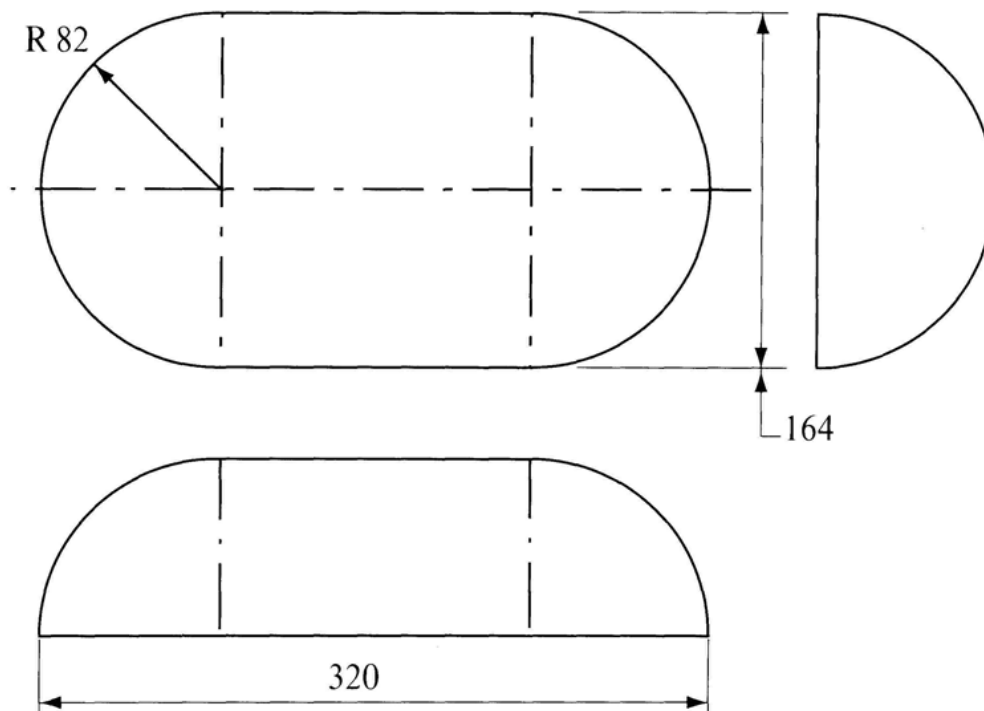

Status: EU Directives are being published on this site to aid cross referencing from UK legislation. After IP completion day (31 December 2020 11pm) no further amendments will be applied to this version.

Appendix 6

Energy absorption characteristics of the rear part of seat backs for vehicles in categories M₂ and M₃

1. [^{X1}Elements of the rear part of seat backs situated in the reference zone, as defined in Paragraph 2.21 of this Annex, shall be verified at the request of the manufacturer according to the energy absorbing requirements set out in Annex III of Directive 74/60/EEC. For this purpose, all accessories fitted shall be tested in all positions of use, except tables which shall be considered in the stowed position.]
2. This test shall be referred to in the Addendum to the Approval Certificate of the seat (Appendix 4 of Annex 1). A drawing showing the area of the rear part of the seat back, verified by the energy dissipation test, shall be enclosed.
3. This test may be applied to parts of a vehicle other than a seat (Paragraph 3.5.3 of Appendix 1).]

[^{F1}ANNEX IV

GENERAL SPECIFICATIONS FOR VEHICLES NOT COVERED BY ANNEXES II AND III

1. General
 - [^{F3}1.1. The requirements set out in this Annex apply to vehicles of categories N₁, N₂ and N₃ and to those of categories M₂ and M₃ not covered by the scope of Annex III. With the exception of the provisions of point 2.5, the requirements also apply to side-facing seats of all categories of vehicles.]
 2. General specifications
 - 2.1. Seats and bench seats must be firmly attached to the vehicle.
 - 2.2. Sliding seats and bench seats must be automatically lockable in all the positions provided.
 - 2.3. Adjustable seat backs must be lockable in all the positions provided.
 - [^{F3}2.4. All seats which can be tipped forward or have fold-on backs must lock automatically in the normal position. This requirement does not apply to seats fitted in the wheelchair spaces of vehicles of category M₂ or M₃ of class I, II or A.]
 - 2.5. A head restraint shall be mounted on every outboard front seat in every vehicle of category M₂ with a maximum mass not exceeding 3 500 kg and of category N₁; head restraints mounted in such vehicles shall comply with the requirements of Annex II or of Directive 78/932/EEC.]

Status: EU Directives are being published on this site to aid cross referencing from UK legislation. After IP completion day (31 December 2020 11pm) no further amendments will be applied to this version.

- (1) [OJ No C 108, 10. 12. 1973, p. 75.](#)
- (2) [OJ No L 42, 23. 2. 1970, p. 1.](#)
- (3) [OJ No L 38, 11. 2. 1974, p. 2.](#)
- (4) [OJ No L 165, 20. 6. 1974, p. 16.](#)
- (5) EEC document from Geneva.

((E/ECE/324/)	Rev. 1/Add. 16.
	E/ECE/TRANS/505)		

- (6) [^{F2}OJ L 42, 13.2.2002, p. 1.]
- (7) [^{F2}OJ L 220, 29.8.1977, p. 95. Directive as last amended by the 2003 Act of Accession.
- (8) [OJ L 24, 30.1.1976, p. 6.](#) Directive as last amended by Commission Directive 96/38/EC ([OJ L 187, 26.7.1996, p. 95.](#))]
- (9) [^{F1}The item numbers and footnotes used in this information Document correspond to those set out in Annex I to Directive 70/156/EEC. Items not relevant for the purpose of this Directive are omitted.
- (10) Delete where not applicable
- (11) If the means of identification of type contains characters not relevant to a description of the vehicle, component or separate technical unit types covered by this type-approval certificate, such characters shall be represented in the documentation by the symbol ‘?’ (e.g. ABC??123??).
- (12) As defined in Annex II A to Directive 70/156/EEC
- (13) Delete where not applicable
- (14) Delete where not applicable
- (15) If the means of identification of type contains characters not relevant to a description of the vehicle, component or separate technical unit types covered by this type-approval certificate, such characters shall be represented in the documentation by the symbol ‘?’ (e. g. ABC??123??).
- (16) As defined in Annex II A to Directive 70/156/EEC.
- (17) Delete where not applicable]
- (18) [^{F1}Vehicles of category M₁ are considered to comply with the provisions of paragraphs 3.2.3 and 3.2.4 of this Annex provided that they comply with the provisions of Directive 74/60/EEC.
- (19) Until 1. 10. 1999 for new vehicle types and 1. 10. 2001 for all vehicles, the value of 750 mm shall apply.
- (20) Until 1. 10. 1999 for new vehicle types and 1. 10. 2001 for all vehicles, the value of 700 mm shall apply.
- (21) The relationship of the reduced mass ‘m_r’ of the pendulum to the total mass ‘m’ of the pendulum at a distance ‘a’ between the centre of percussion and the axis of rotation and at a distance ‘l’ between the centre of gravity and the axis of rotation is given by the formula: m_r = m. l/a.]
- (22) [^{F1}The technical specifications and detailed drawings of Hybrid II and III, corresponding to the principal dimensions of a fiftieth percentile male of the United States of America, and the specifications for its adjustment for this test are deposited with the Secretary-General of the United Nations and may be consulted on request at the secretariat of the Economic Commission for Europe, Palais des Nations, Geneva, Switzerland.
- (23) Expressed in g (= 9,81 m/sec²) the scalar value of which is calculated according to the following formula:

$$\gamma_r^2 = \gamma_l^2 + \gamma_v^2 + \gamma_t^2$$

where:	γ_l	= value of instant longitudinal acceleration,
--------	------------	---

Status: EU Directives are being published on this site to aid cross referencing from UK legislation. After IP completion day (31 December 2020 11pm) no further amendments will be applied to this version.

γ_v	= value of instant vertical acceleration,
γ_t	= value of instant transversal acceleration.

Textual Amendments

- F1** Substituted by Commission Directive 96/37/EC of 17 June 1996 adapting to technical progress Council Directive 74/408/EEC relating to the interior fittings of motor vehicles (strength of seats and of their anchorages) (Text with EEA relevance).
- F2** Inserted by Directive 2005/39/EC of the European Parliament and of the Council of 7 September 2005 amending Council Directive 74/408/EEC relating to motor vehicles with regard to the seats, their anchorages and head restraints (Text with EEA relevance).