

This document is meant purely as a documentation tool and the institutions do not assume any liability for its contents

► **B** **COUNCIL DIRECTIVE**
of 1 March 1971
on the approximation of the laws of the Member States relating to the rear-view mirrors of motor vehicles
(71/127/EEC)
(OJ L 68, 22.3.1971, p. 1)

Amended by:

	Official Journal		
	No	page	date
► <u>M1</u> Commission Directive 79/795/EEC of 20 July 1979	L 239	1	22.9.1979
► <u>M2</u> Commission Directive 85/205/EEC of 18 February 1985	L 90	1	29.3.1985
► <u>M3</u> Commission Directive 86/562/EEC of 6 November 1986	L 327	49	22.11.1986
► <u>M4</u> Council Directive 87/354/EEC of 25 June 1987	L 192	43	11.7.1987
► <u>M5</u> Commission Directive 88/321/EEC of 16 May 1988	L 147	77	14.6.1988

Amended by:

► <u>A1</u> Act of Accession of Denmark, Ireland and the United Kingdom of Great Britain and Northern Ireland (adapted by Council Decision of 1 January 1973)	L 73 L 2	14 1	27.3.1972 1.1.1973
► <u>A2</u> Act of Accession of Greece	L 291	17	19.11.1979
► <u>A3</u> Act of Accession of Spain and Portugal	L 302	23	15.11.1985
► <u>A4</u> Act of Accession of Austria, Sweden and Finland (adapted by Council Decision 95/1/EC, Euratom, ECSC)	C 241 L 1	21 1	29.8.1994 1.1.1995
► <u>A5</u> Act concerning the conditions of accession of the Czech Republic, the Republic of Estonia, the Republic of Cyprus, the Republic of Latvia, the Republic of Lithuania, the Republic of Hungary, the Republic of Malta, the Republic of Poland, the Republic of Slovenia and the Slovak Republic and the adjustments to the Treaties on which the European Union is founded	L 236	33	23.9.2003

Corrected by:

- **C1** Consolidated text of corrigenda to instruments published in Special Editions 1952-72, p. 85 (71/127/EEC)

▼B**COUNCIL DIRECTIVE****of 1 March 1971****on the approximation of the laws of the Member States relating to the rear-view mirrors of motor vehicles**

(71/127/EEC)

THE COUNCIL OF THE EUROPEAN COMMUNITIES,

Having regard to the Treaty establishing the European Economic Community, and in particular Article 100 thereof;

Having regard to the proposal from the Commission;

Having regard to the Opinion of the European Parliament ⁽¹⁾;

Having regard to the Opinion of the Economic and Social Committee ⁽²⁾;

Whereas the technical requirements which motor vehicles must satisfy pursuant to national laws relate, *inter alia*, to their rear-view mirrors;

Whereas those requirements differ from one Member State to another; whereas it is therefore necessary that all Member States adopt the same requirements either in addition to or in place of their existing requirements, in order, in particular, to allow the EEC type-approval procedure which was the subject of the Council Directive of 6 February 1970 ⁽³⁾ on the approximation of the laws of the Member States relating to the type-approval of motor vehicles and their trailers to be applied in respect of each type of vehicle;

Whereas rules on rear-view mirrors should lay down requirements concerning not only how such mirrors should be fitted on vehicles but also their construction;

Whereas a harmonised type-approval procedure for rear-view mirrors makes it possible for each Member State to check compliance with the common construction and testing requirements and to inform the other Member States of its findings by sending a copy of the type-approval certificate completed for each type of rear-view mirror; whereas the placing of an EEC type-approval mark on all mirrors manufactured in conformity with the approved type obviates any need for technical checks on these mirrors in the other Member States;

HAS ADOPTED THIS DIRECTIVE:

Article 1

1. Each Member State shall approve any type of rear-view mirror which satisfies the construction and testing requirements laid down in ►**M2** Annex II ◀.

2. The Member State which has granted type approval shall take the measures required in order to verify, in so far as is necessary and if need be in co-operation with the competent authorities in the other Member States, that production models conform to the approved type. Such verification shall be limited to spot checks.

Article 2

Member States shall issue to the manufacturer, or to his authorised representative, an EEC type-approval mark which shall conform to the model shown in ►**M2** Appendix 2 to Annex II ◀, for each type of rear-view mirror which they approve pursuant to Article 1.

⁽¹⁾ OJ No C 160, 18.12.1969, p. 7.

⁽²⁾ OJ No C 48, 16.4.1969, p. 16.

⁽³⁾ OJ No L 42, 23.2.1970, p. 1.

▼B

Member States shall take all appropriate measures to prevent the use of marks liable to create confusion between rear-view mirrors which have been type-approved pursuant to Article 1 and other mirrors.

Article 3

1. No Member State may prohibit the placing on the market of rear-view mirrors on grounds relating to their construction or method of functioning if they bear the EEC type-approval mark.

2. Nevertheless, this provision shall not prevent a Member State from taking such measures in respect of rear-view mirrors bearing the EEC type-approval mark which, by their design, do not conform to the approved prototype.

That State shall inform the other Member States and the Commission forthwith of the measures taken, specifying the reasons for its decision. The provisions of Article 5 shall also apply.

▼M1

There shall be failure to conform to the approved type, within the meaning of the first subparagraph, where the requirements of ►**M2** Annex II ◀ are not observed.

▼B*Article 4*

The competent authorities of each Member State shall within one month send to the competent authorities of the other Member States a copy of the type-approval certificates completed for each type of rear-view mirror which they approve or refuse to approve.

Article 5

1. If the Member State which has granted EEC type-approval finds that a number of rear-view mirrors bearing the same type-approval mark do not conform to the type which it has approved, it shall take the necessary measures to ensure that production models conform to the approved type. The competent authorities of that State shall advise those of the other Member States of the measures taken, which may, where necessary, extend to withdrawal of EEC type-approval. The said authorities shall take the same measures if they are informed by the competent authorities of another Member State of such failure to conform.

2. The competent authorities of Member States shall inform each other within one month of any withdrawal of EEC type-approval, and of the reasons for such measure.

3. If the Member State which has granted EEC type-approval disputes the failure to conform notified to it, the Member States concerned shall endeavour to settle the dispute. The Commission shall be kept informed and shall, where necessary, hold appropriate consultations for the purpose of reaching a settlement.

Article 6

All decisions taken pursuant to the provisions adopted in implementation of this Directive which refuse or withdraw type-approval for a rear-view mirror or prohibit its use shall set out in detail the reasons on which they are based. A decision shall be notified to the party concerned, who shall at the same time be informed of the remedies available to him under the laws in force in the Member States and of the time limits allowed for the exercise of such remedies.

▼M2*Article 7*

1. With effect from 1 October 1985, no Member State may, on grounds relating to rear-view mirrors:

- (a) — refuse, in respect of a type of motor vehicle, to grant EEC type-approval, to issue the document referred to in the third indent of Article 10 (1) of Directive 70/156/EEC, or to grant national type-approval, or

— prohibit the entry into service of the vehicles,

if the rear-view mirrors of this type of vehicle or of these vehicles comply with the provisions of this Directive;

- (b) — refuse, in respect of a type of rear-view mirror, to grant EEC component type-approval or national type-approval, if these rear-view mirrors comply with the provisions of this Directive, or

— prohibit the placing on the market of rear-view mirrors which bear the EEC component type-approval mark issued in accordance with the requirements of this Directive.

2. With effect from 1 October 1986 a Member State:

- (a) — shall not issue the document referred to in the third indent of Article 10 (1) of Directive 70/156/EEC in respect of a type of vehicle of which the rear-view mirrors do not comply with the provisions of this Directive,

— may refuse to grant national type-approval in respect of a type of vehicle of which the rear-view mirrors do not comply with the provisions of this Directive;

- (b) — shall not grant EEC component type-approval in respect of a type of rear-view mirror if the latter does not comply with the provisions of this Directive,

— may refuse to grant national component type-approval in respect of a type of rear-view mirror if the latter does not comply with the provisions of this Directive.

3. With effect from 1 October 1988, Member States may prohibit the entry into service of vehicles — with the exception of those referred to in item 2.1.3 of Annex III — of which the rear-view mirrors do not comply with the provisions of this Directive.

With effect from 1 October 1992, Member States may prohibit the entry into service of vehicles referred to in item 2.1.3 of Annex III of which the rear-view mirrors do not comply with the provisions of this Directive. They may likewise prohibit the placing on the market of rear-view mirrors which do not bear the component type-approval mark issued in accordance with the requirements of this Directive.

▼A1*Article 7a*

No Member State may refuse or prohibit the sale or registration, entry into service or use of a vehicle on grounds relating to its rear-view mirrors if these comply with the requirements laid down in the Annexes.

▼B*Article 8*

For the purposes of this Directive, ‘vehicle’ means any motor vehicle intended for use on the road, with or without bodywork, having at least four wheels and a maximum design speed exceeding 25 km/h, with the exception of vehicles which run on rails, agricultural tractors and machinery, and public works vehicles.

Article 9

The amendments necessary for adjusting the requirements of Annexes I, II and III so as to take account of technical progress shall be adopted in accordance with the procedure laid down in Article 13 of the

▼B

Council Directive of 6 February 1970 on the approximation of the laws of the Member States relating to the type approval of motor vehicles and their trailers.

Article 10

1. Member States shall put into force provisions containing the requirements needed in order to comply with this Directive within eighteen months of its notification and shall forthwith inform the Commission thereof.
2. Member States shall ensure that the texts of the main provisions of national law which they adopt in the field governed by this Directive are communicated to the Commission.

Article 11

This Directive is addressed to the Member States.

▼ M2

ANNEX I

DEFINITIONS

1. *Rear-view mirror* means any device, excluding complex optical systems such as periscopes, intended to give a clear view to the rear and side of the vehicle within the fields of vision defined in item 5 of Annex III.
2. *Interior rear-view mirror* means a device as defined in item 1 which can be fitted in the passenger compartment of a vehicle.
3. *Exterior rear-view mirror* means a device as defined in item 1 which can be mounted on the external surface of a vehicle.
4. *Surveillance rear-view mirror* means a rear-view mirror other than a device of the type defined in item 1 which can be fitted to the inside or outside of the vehicle in order to provide fields of vision other than those specified in item 5 of Annex III.
5. *Rear-view mirror type* means devices which do not differ significantly in respect of the following essential characteristics:
 - 5.1. the dimensions and radius of curvature of the rear-view mirror's reflecting surface;
 - 5.2. the design, shape or materials of the rear-view mirrors, including the connection with the bodywork.
6. *Class of rear-view mirror* means all devices having one or more common characteristics or functions. They are classified as follows:

Class I:	Interior rear-view mirrors, giving the field of vision defined in item 5.2 of Annex III.
Classes II and III:	'Main' exterior rear-view mirrors, giving the fields of vision defined in item 5.3 of Annex III.
Class IV:	'Wide-angle' exterior rear-view mirrors, giving the field of vision defined in item 5.4 of Annex III.
Class V:	'Close-proximity' exterior rear-view mirrors, giving the field of vision defined in item 5.5 of Annex III.
7. *r* means the average of the radii of curvature measured over the reflecting surface, in accordance with the method described in item 2 of Appendix 1 to this Annex.
8. *The principal radii of curvature at one point on the reflecting surface (r)* means the values obtained with the apparatus defined in Appendix 1, measured on the arc of the reflecting surface passing through the centre of this surface parallel to the segment b, as defined in item 2.2.1 of Annex II and on the arc perpendicular to this segment.
9. *The radius of curvature at one point on the reflecting surface (r_p)* means the arithmetical average of the principal radii of curvature r_i and r'_i i.e.:

$$r_p = \frac{r_i + r'_i}{2}$$
10. *Centre of the reflecting surface* means the centroid of the visible area of the reflecting surface.
11. *The radius of curvature of the constituent parts of the rear-view mirror* means the radius 'c' of the arc of the circle which most closely approximates to the curved form of the part in question.
12. *The driver's ocular points* means two points 65 mm apart and 635 mm vertically above point R of the driver's seat as defined in Appendix 2 to this Annex. The straight line joining these points runs perpendicular to the vertical longitudinal median plane of the vehicle. The centre of the segment joining the two ocular points is in a vertical longitudinal plane which must pass through the centre of the driver's designated seating position, as specified by the vehicle manufacturer.
13. *Ambinocular vision* means the total field of vision obtained by the superimposition of the monocular fields of the right eye and the left eye (see diagram below).

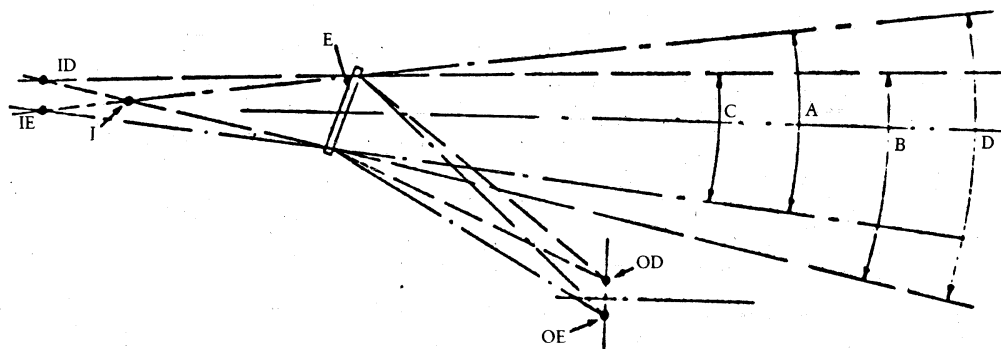
▼ M2

E	=	interior rear-view mirror
OD	}	= driver's eyes
OE		
ID	}	= virtual monocular images
IE		
I	=	virtual ambinoocular image
A	=	angle of vision of left eye
B	=	angle of vision of right eye
C	=	binocular angle of vision
D	=	ambinoocular angle of vision

14. *Type of vehicle as regards rear-view mirrors* means motor vehicles which are identical in respect of the following basic features:
- 14.1. the bodywork features which reduce the field of vision;
 - 14.2. the coordinates of point R;
 - 14.3. the prescribed positions and types of compulsory and (if fitted) optional rear-view mirror.
15. *Vehicles of categories M_1 , M_2 , M_3 , N_1 , N_2 , N_3* means those defined in Annex I to Directives 70/156/EEC.

▼ **M2***Appendix 1 to Annex I***PROCEDURE FOR DETERMINING THE RADIUS OF CURVATURE 'r'
OF THE REFLECTING SURFACE OF A REAR-VIEW MIRROR**

1. MEASUREMENTS

1.1. **Equipment**

The 'spherometer' described in Figure 1 is used.

1.2. **Measuring points**

- 1.2.1. The principal radii of curvature shall be measured at three points situated as close as possible to positions at one-third, one-half and two-thirds of the distance along the arc of the reflecting surface passing through the centre of this surface and parallel to segment b, or of the arc passing through the centre of the reflecting surface which is perpendicular to it if this arc is the longer.
- 1.2.2. Where, owing to the size of the reflecting surface, it is impossible to obtain measurements in the directions defined in item 8 of this Annex, the technical services responsible for the tests may take measurements at the said point in two perpendicular directions as close as possible to those prescribed above.

2. CALCULATION OF THE RADIUS OF CURVATURE 'r'

'r' expressed in mm is calculated from the formula:

$$r = \frac{r_{p1} + r_{p2} + r_{p3}}{3}$$

where:

- r_{p1} = the radius of curvature at the first measuring point,
 r_{p2} = the radius of curvature at the second measuring point,
 r_{p3} = the radius of curvature at the third measuring point.

▼M2

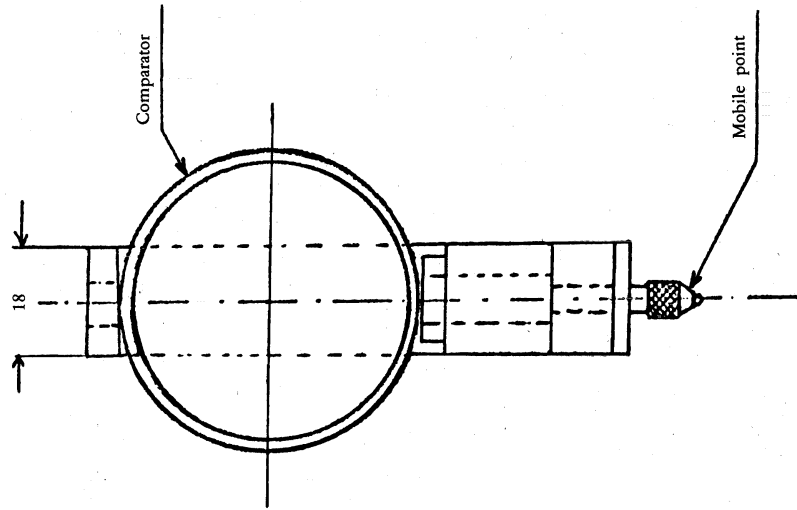

[∇]

Figure 1

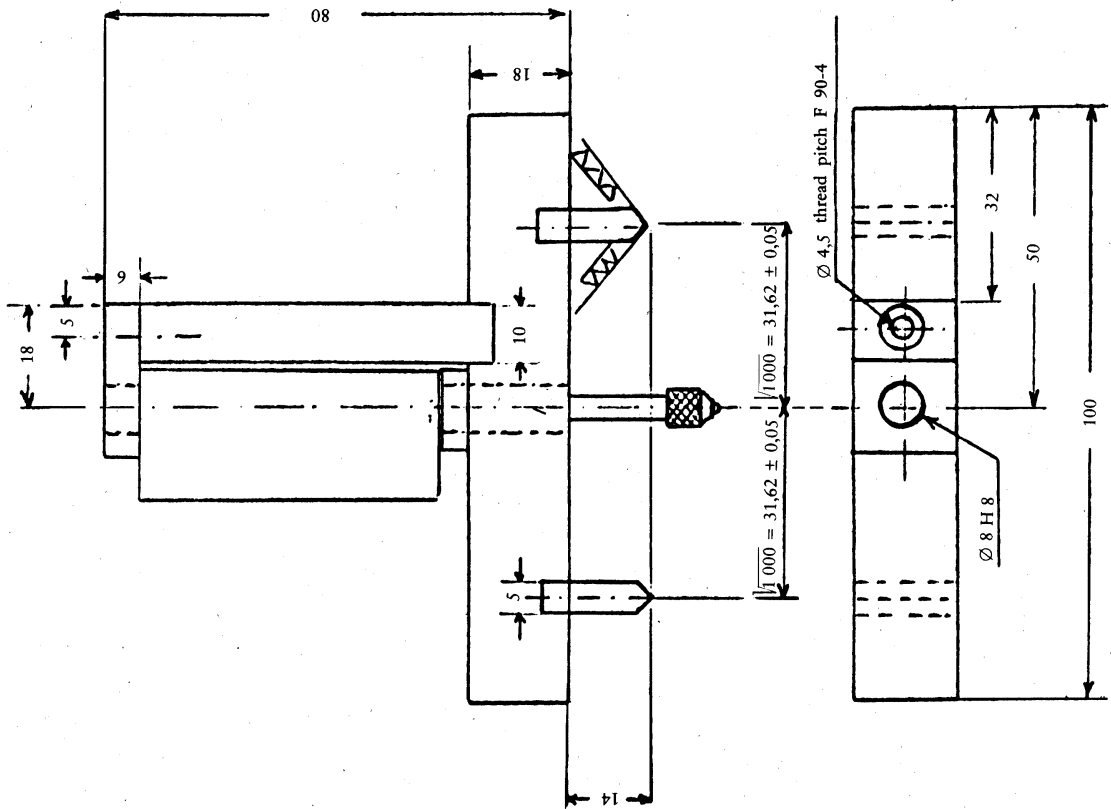

▼ M2

Appendix 2 to Annex I

**PROCEDURE FOR DETERMINING THE H POINT AND VERIFYING
THE RELATIVE POSITIONS OF THE R AND H POINTS**

The relevant parts of Annex III to Directive 77/649/EEC are applicable.

▼ **M2***ANNEX II***DESIGN SPECIFICATIONS AND TESTS REQUIRED FOR EEC COMPONENT TYPE-APPROVAL OF REAR-VIEW MIRRORS**

1. GENERAL SPECIFICATIONS
- 1.1. All rear-view mirrors must be adjustable.
- 1.2. The edge of the reflecting surface must be enclosed in a protective housing (holder, etc.) which, on its perimeter, must have a value 'c' greater than or equal to 2,5 mm at all points and in all directions. If the reflecting surface projects beyond the protective housing, the radius of curvature 'c' on the edge of the projecting part must be not less than 2,5 mm and the reflecting surface must return into the protective housing under a force of 50 N applied to the point of greatest projection, relative to the protective housing, in a horizontal direction, approximately parallel to the longitudinal median plane of the vehicle.
- 1.3. When the rear-view mirror is mounted on a plane surface, all parts, irrespective of the adjustment position of the device, including those parts remaining attached to the support after the test provided for in 4.2, which are in potential, static contact with a sphere either 165 mm in diameter in the case of an interior rear-view mirror or 100 mm in diameter in the case of an exterior rear-view mirror, must have a radius of curvature 'c' of not less than 2,5 mm.
- 1.3.1. Edges of fixing holes or recesses of which the diameter or longest diagonal is less than 12 mm are exempt from the radius requirements of item 1.3 provided that they are blunted.
- 1.4. The device for the attachment of rear-view mirrors to the vehicle must be so designed that a cylinder with a 50 mm radius, having as its axis the axis, or one of the axes, of pivot or rotation which ensures deflection of the rear-view mirror in the direction of impact concerned, passes through at least part of the surface to which the device is attached.
- 1.5. The parts of exterior rear-view mirrors referred to in items 1.2 and 1.3 which are made of a material with a Shore A hardness not exceeding 60 are exempt from the relevant provisions.
- 1.6. In the case of those parts of interior rear-view mirrors which are made of a material with a Shore A hardness of less than 50 and which are mounted on a rigid support, the requirements of items 1.2 and 1.3 shall only apply to the support.
2. DIMENSIONS
- 2.1. **Interior rear-view mirrors (Class I)**
- The dimensions of the reflecting surface must be such that it is possible to inscribe thereon a rectangle one side of which is 4 cm and the other 'a' cm in length, where
- $$a = 15 \text{ cm} \times \frac{1}{1 + \frac{1000}{r}}$$
- 2.2. **Main exterior rear-view mirrors (Classes II and III)**
- 2.2.1. The dimensions of the reflecting surface must be such that it is possible to inscribe therein:
- a rectangle 4 cm high the base length of which, measured in centimetres, has the value 'a';
 - a segment which is parallel to the height of the rectangle and the length of which, expressed in centimetres, has the value 'b'.
- 2.2.2. The minimum values of 'a' and 'b' are given in the table below:

▼ **M2**

Class of rear-view mirror	Categories of vehicles for which the rear-view mirrors are designed	a	b
II	M ₂ , M ₃ , N ₂ and N ₃	$\frac{17}{1 + \frac{1000}{r}}$	20
III	► M5 M ₁ , N ₁ and N ₂ ◀ N ₃ (if the requirements of item 2.1.3 of Annex III are applicable)	$\frac{13}{1 + \frac{1000}{r}}$	7

2.3. **‘Wide-angle’ exterior rear-view mirrors (Class IV)**

The contours of the reflecting surface must be of simple geometric form and its dimensions such that it provides, if necessary in conjunction with a Class II exterior rear-view mirror, the field of vision specified in item 5.4 of Annex III.

2.4. **‘Close-proximity’ exterior rear-view mirrors (Class V)**

The contours of the reflecting surface must be of simple geometric form and its dimensions such that the mirror provides the field of vision specified in item 5.5 of Annex III.

3. REFLECTING SURFACE AND COEFFICIENTS OF REFLECTION

3.1. The reflecting surface of a rear-view mirror must be either flat or spherically convex.

3.2. **Differences between the radii of curvature**

3.2.1. The difference between r_i or r'_i and r_p at each reference point must not exceed 0,15 r.

3.2.2. The difference between any of the radii of curvature (r_{p1} , r_{p2} and r_{p3}) and r must not exceed 0,15 r.

3.2.3. When r is not less than 3 000 mm, the value of 0,15 r quoted in items 3.2.1 and 3.2.2 is replaced by 0,25 r.

3.3. The value of ‘r’ must not be less than:

3.3.1. 1 200 mm for interior rear-view mirrors (Class I) and Class III main exterior rear-view mirrors;

3.3.2. 1 800 mm for Class II main exterior rear-view mirrors;

3.3.3. 400 mm for ‘wide-angle’ exterior rear-view mirrors (Class IV) and ‘close-proximity’ exterior rear-view mirrors (Class V).

3.4. The value of the normal coefficient of reflection, as determined according to the method described in Appendix I to this Annex, must be not less than 40 %.

If the reflecting surface has two positions (‘day’ and ‘night’) the ‘day’ position must allow the colours of the signals used for road traffic to be recognized. The value of the normal coefficient of reflection in the ‘night’ position must be not less than 4 %.

3.5. The reflecting surface must retain the characteristics laid down in item 3.4 in spite of prolonged exposure to adverse weather conditions in normal use.

4. TESTS

4.1. Rear-view mirrors shall be subjected to the tests described in items 4.2 and 4.3.

4.1.1. The test provided for in item 4.2 shall not be required in the case of any exterior rear-view mirror of which no part is less than 2 m from the ground, regardless of the adjustment position, when the vehicle is under a load corresponding to its maximum technically permissible weight.

This derogation also applies to the attachments of rear-view mirrors (attachment plates, arms, swivel joints, etc.) which are situated less than 2 m from the ground and which do not project beyond the

▼ **M2**

overall width of the vehicle, measured in the transverse plane passing through the lowest rear-view mirror attachments or any other point forward of this plane if this configuration produces a greater overall width.

In such cases, a description specifying that the rear-view mirror must be mounted so as to conform with the abovementioned conditions for the positioning of its attachments on the vehicle must be provided.

Where advantage is taken of this derogation, the arm shall be indelibly marked with the symbol \hat{m} and the type-approval certificate shall be endorsed to this effect.

4.2. Impact test

4.2.1. Description of the test rig

4.2.1.1. The test rig consists of a pendulum capable of swinging about two horizontal axes at right angles to each other, one of which is perpendicular to the plane containing the 'release' trajectory of the pendulum.

The end of the pendulum comprises a hammer formed by a rigid sphere with a diameter of 165 ± 1 mm having a 5-mm-thick rubber covering of Shore A hardness 50.

A device is provided which permits determination of the maximum angle assumed by the arm in the plane of release.

A support firmly fixed to the structure of the pendulum serves to hold the specimens in compliance with the impact requirements specified in item 4.2.2.6.

Figure 1 below gives the dimensions of the test rig and the special design specifications.

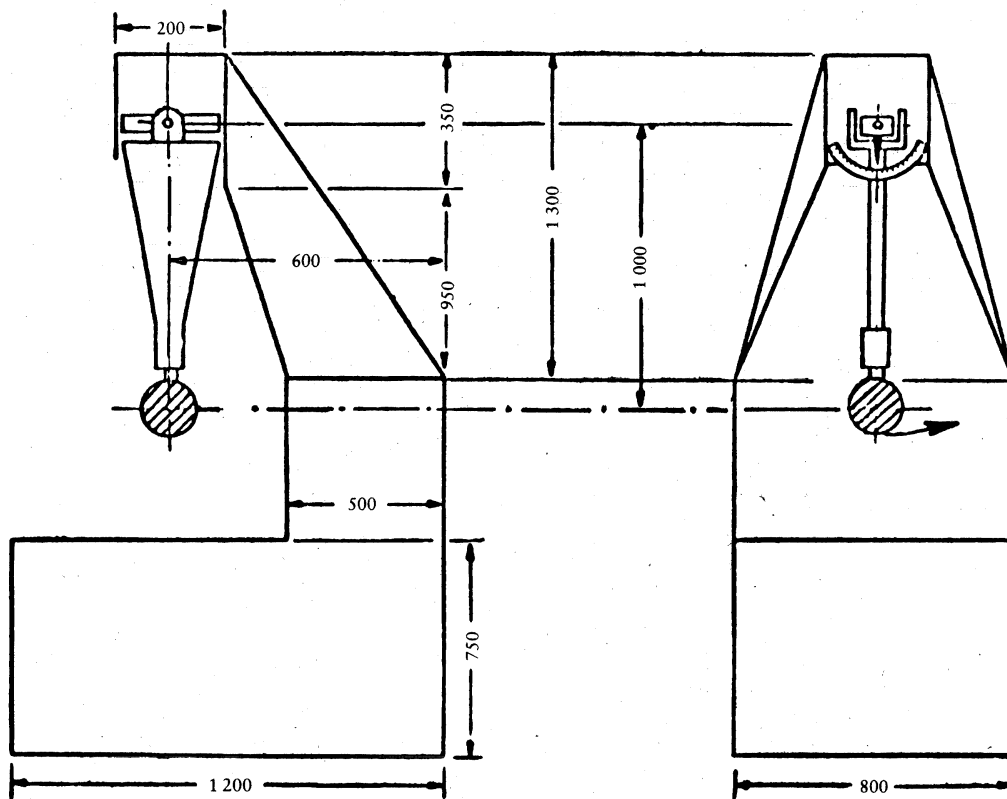

Figure 1

4.2.1.2. The centre of percussion of the pendulum coincides with the centre of the sphere which forms the hammer. It is at a distance '1' from the axis of oscillation in the release plane which is equal to $1 \text{ m} \pm 5 \text{ mm}$. The reduced mass of the pendulum is $m_0 = 6,8 \pm 0,05$ kilograms (the relationship of 'm' to the total mass 'm' of the pendulum and to the

▼ **M2**

distance 'd' between the centre of gravity of the pendulum and its axis of rotation is expressed in the equation:

$$m_0 = m \frac{d}{l}$$

4.2.2. *Description of the test*

4.2.2.1. The procedure used to clamp the rear-view mirror to the support shall be that recommended by the manufacturer of the device or, where appropriate, by the vehicle manufacturer.

4.2.2.2. Positioning of the rear-view mirror for the test

4.2.2.2.1. Rear-view mirrors shall be positioned on the pendulum impact rig such that the axes which are horizontal and vertical when the rear-view mirror is installed on a vehicle in accordance with the applicant's mounting instructions are in a similar position.

4.2.2.2.2. When a rear-view mirror is adjustable with respect to the base, the test position shall be that in which any pivoting device is least likely to operate, within the limits of adjustment provided by the applicant.

4.2.2.2.3. When the rear-view mirror has a device for adjusting its distance from the base, the device must be set in the position in which the distance between the housing and the base is shortest.

4.2.2.2.4. When the reflecting surface is mobile in the housing, it shall be so adjusted that the upper corner which is furthest from the vehicle is in the position of greatest projection relative to the housing.

4.2.2.3. Except in the case of test 2 for interior rear-view mirrors (see item 4.2.2.6.1), when the pendulum is in a vertical position the horizontal and longitudinal vertical planes passing through the centre of the hammer shall pass through the centre of the reflecting surface as defined in item 10 of Annex I. The longitudinal direction of oscillation of the pendulum shall be parallel to the longitudinal median plane of the vehicle.

4.2.2.4. When, under the conditions governing adjustment laid down in items 4.2.2.1 and 4.2.2.2 parts of the rear-view mirror limit the return of the hammer, the point of impact must be displaced in a direction perpendicular to the axis of rotation or pivoting in question.

The displacement must be no greater than is strictly necessary for the execution of the test; it must be limited in such a way that:

- either the sphere delimiting the hammer remains at least tangential to the cylinder as defined in paragraph 1.4;
- or the point of contact with the hammer is located at least 10 mm from the periphery of the reflecting surface.

4.2.2.5. The test consists in allowing the hammer to fall from a height corresponding to a pendulum angle of 60° from the vertical so that the hammer strikes the rear-view mirror at the moment when the pendulum reaches the vertical position.

4.2.2.6. The rear-view mirrors are subjected to impact under the following different conditions:

4.2.2.6.1. Interior rear-view mirrors

Test 1: The points of impact shall be as defined in item 4.2.2.3. The impact must be such that the hammer strikes the rear-view mirror on the reflecting surface side.

Test 2: Point of impact on the edge of the protective housing, such that the impact produced makes an angle of 45° with the plane of the reflecting surface and is situated in the horizontal plane passing through the centre of that surface. The impact must occur on the reflecting surface side.

4.2.2.6.2. Exterior rear-view mirrors

Test 1: The point of impact shall be as defined in item 4.2.2.3 or 4.2.2.4. The impact must be such that the hammer strikes the rear-view mirror on the reflecting surface side.

Test 2: The point of impact shall be as defined in item 4.2.2.3 or 4.2.2.4. The impact must be such that the hammer strikes the rear-view mirror on the side opposite to the reflecting surface.

▼ **M2**

Where Class II or III rear-view mirrors are fixed to the same mounting as Class IV rear-view mirrors, the abovementioned tests shall be executed on the lower mirror. Nevertheless, the technical service responsible for testing may repeat one or both of these tests on the upper mirror if this is less than 2 m from the ground.

4.3. Bending test on the protective housing fixed to the stem

4.3.1. This test shall be performed on all rear-view mirrors with the exception of those in Class V.

4.3.2. Description of the test

The protective housing is placed horizontally in a device in such a way that the adjustment parts of the mounting can be clamped securely. In the direction of the greatest dimension of the housing, the end nearest to the point of fixing on the adjustment part is immobilized by means of a fixed stop 15 mm wide covering the entire width of the housing.

At the other end, a stop identical to the one described above is placed on the housing so that the specified test load can be applied to it (Figure 2).

The end of the housing opposite that at which the force is applied may be clamped instead of simply blocked, as shown in Figure 2.

Example of bending-test apparatus for rear-view mirror holders

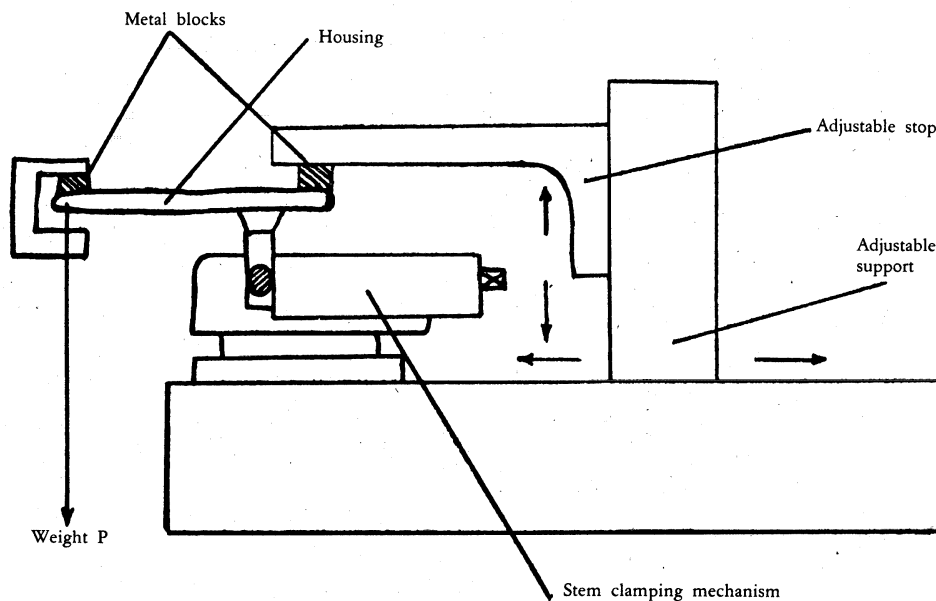

Figure 2

4.3.3. The test load is 25 kilograms. It is applied for one minute.

5. RESULTS OF THE TEST

5.1. In the tests described in item 4.2, the pendulum must continue to swing after impact in such a way that the projection of the position assumed by the arm on the plane of release makes an angle of at least 20 ° with the vertical.

The accuracy of measurement of the angle shall be within $\pm 1^\circ$.

5.1.1. This requirement is not applicable to rear-view mirrors stuck to the windscreen, in respect of which the requirement stipulated in item 5.2 shall apply after the test.

5.1.2. The required pendulum angle of return to the vertical is reduced from 20 ° to 10 ° for all Class II rear-view mirrors and for Class III rear-view mirrors which are fitted on the mounting normally used with Class IV rear-view mirrors.

5.2. Should the mounting of the rear-view mirror break during the tests described in item 4.2. for rear-view mirrors stuck to the windscreen, the part remaining must not project beyond the base by more than

▼ M2

1 cm and the configuration remaining after the test must satisfy the conditions laid down in item 1.3.

- 5.3. The reflecting surface must not break during the tests described in items 4.2 and 4.3. However breakage of the reflecting surface will be allowed if one of the following conditions is fulfilled:
 - 5.3.1. the fragments of glass still adhere to the back of the housing or to a surface firmly attached to the housing; partial separation of the glass from its backing is admissible provided this does not exceed 2,5 mm on either side of the cracks. It is permissible for small splinters to become detached from the surface of the glass at the point of impact;
 - 5.3.2. the reflecting surface is made of safety glass.

TEST METHOD FOR DETERMINING REFLECTIVITY

1. DEFINITIONS

- 1.1. CIE standard illuminant A ⁽¹⁾: Colorimetric illuminant, respecting the full radiator at $T_{68} = 2855,6$ K.
- 1.2. CIE standard source A ⁽¹⁾: Gas-filled tungsten filament lamp operating at a correlated colour temperature of $T_{68} = 2855,6$ K.
- 1.3. CIE 1931 standard colorimetric observer ⁽¹⁾: Receptor of radiation whose colorimetric characteristics correspond to the spectral tristimulus values $\bar{x}(\lambda)$, $\bar{y}(\lambda)$, $\bar{z}(\lambda)$ (see table).
- 1.4. CIE spectral tristimulus values ⁽¹⁾: Tristimulus values of the spectral components of an equi-energy spectrum in the CIE (XYZ) system.
- 1.5. Photopic vision ⁽¹⁾: Vision by the normal eye when it is adapted to levels of luminance of at least several candelas per square metre.

2. APPARATUS

2.1. General

The apparatus shall consist of a light source, a holder for the test sample, a receiver unit with a photo-detector and an indicating meter (see Figure 1), and means of eliminating the effects of extraneous light.

The receiver may incorporate a light-integrating sphere to facilitate measuring the reflectance of non-flat (convex) mirrors (see Figure 2).

2.2. Spectral characteristics of light source and receiver

The light source shall consist of a CIE standard source A and associated optics to provide a near-collimated light beam. A voltage stabilizer is recommended in order to maintain a fixed lamp voltage during instrument operation.

The receiver shall have a photodetector with a spectral response proportional to the photopic luminosity function of the CIE (1931) standard colorimetric observer (see table). Any other combination of illuminant-filter-receptor giving the overall equivalent of CIE standard illuminant A and photopic vision may be used. When an integrating sphere is used in the receiver, the interior surface of the sphere shall be coated with a matt (diffusive) spectrally non-selective white coating.

2.3. Geometrical conditions

The angle of the incident beam (Θ) should preferably be $0,44 \pm 0,09$ rad ($25 \pm 5^\circ$) from the perpendicular to the test surface and shall not exceed the upper limit of the tolerance (i.e. $0,53$ rad or 30°). The axis of the receptor shall make an angle (Θ) with this perpendicular equal to that of the incident beam (see Figure 1). The incident beam upon arrival at the test surface shall have a diameter of not less than 19 mm ($0,75$ in.). The reflected beam shall not be wider than the sensitive area of the photodetector, shall not cover less than 50 % of such area, and as nearly as possible shall cover the same area segment as used during instrument calibration.

When an integrating sphere is used in the receiver section, the sphere shall have a minimum diameter of 127 mm (5 in.). The sample and incident beam apertures in the sphere wall shall be of such a size as to admit the entire incident and reflected light beams. The photodetector shall be so located as not to receive direct light from either the incident or the reflected beam.

2.4. Electrical characteristics of the photodetector-indicator unit

The photodetector output as read on the indicating meter shall be a linear function of the light intensity of the photosensitive area. Means (electrical and/or optical) shall be provided to facilitate zeroing and calibration adjust-

⁽¹⁾ Definitions taken from CIE publication 50 (45), International Electrotechnical Vocabulary, Group 45: Lighting.

▼ **M2**

ments. Such means shall not affect the linearity or the spectral characteristics of the instrument. The accuracy of the receptor-indicator unit shall be within $\pm 2\%$ of full scale, or $\pm 10\%$ of the magnitude of the reading, whichever is the smaller.

2.5. Sample holder

The mechanism shall be capable of locating the test sample so that the axes of the source arm and receptor intersect at the reflecting surface. The reflecting surface may lie within or at either face of the mirror sample, depending on whether it is a first-surface, second-surface or prismatic 'flip'-type mirror.

3. PROCEDURE**3.1. Direct calibration method**

In the direct calibration method, air is used as the reference standard. This method is applicable for those instruments which are so constructed as to permit calibration at the 100 % point by swinging the receiver to a position directly on the axis of the light source (see Figure 1).

It may be desired in some cases (such as when measuring low-reflectivity surfaces) to use an intermediate calibration point (between 0 and 100 % on the scale) with this method. In these cases, a neutral density filter of known transmittance shall be inserted in the optical path, and the calibration control shall then be adjusted until the meter reads the percentage transmission of the neutral density filter. This filter shall be removed before reflectivity measurements are performed.

3.2. Indirect calibration method

The indirect calibration method is applicable in the case of instruments with fixed source and receiver geometry. A properly calibrated and maintained reflectance standard is required. This reference standard should preferably be a flat mirror with a reflectance value as near as possible to that of the test samples.

3.3. Flat mirror measurement

The reflectance of flat mirror samples can be measured on instruments employing either the direct or the indirect calibration method. The reflectance value is read directly from the indicating meter.

3.4. Non-flat (convex) mirror measurement

Measurement of the reflectance of non-flat (convex) mirrors requires the use of instruments which incorporate an integrating sphere in the receiver unit (see Figure 2). If the instrument indicating meter indicates n_x divisions with a standard mirror of $E\%$ reflectance, then, with a mirror of unknown reflectance, n_x divisions will correspond to a reflectance of $X\%$, in accordance with the formula:

$$X = E \frac{n_x}{n_e}$$

▼ M2

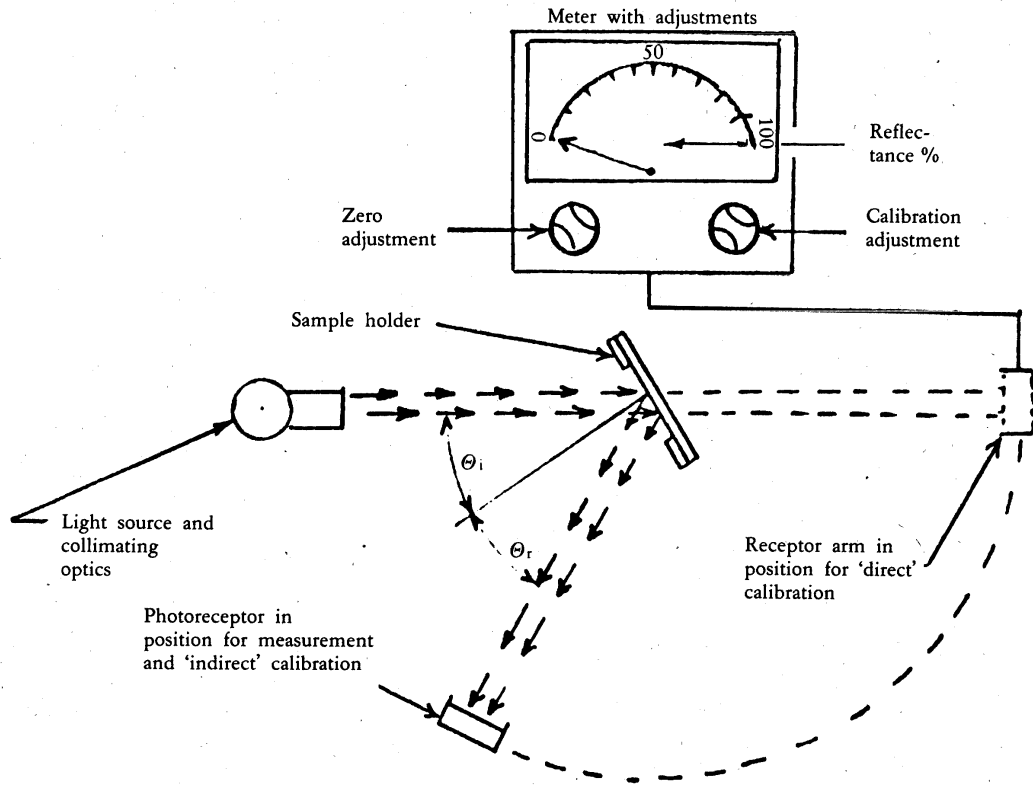

Figure 1. Generalized reflectometer showing geometries for the two calibration methods

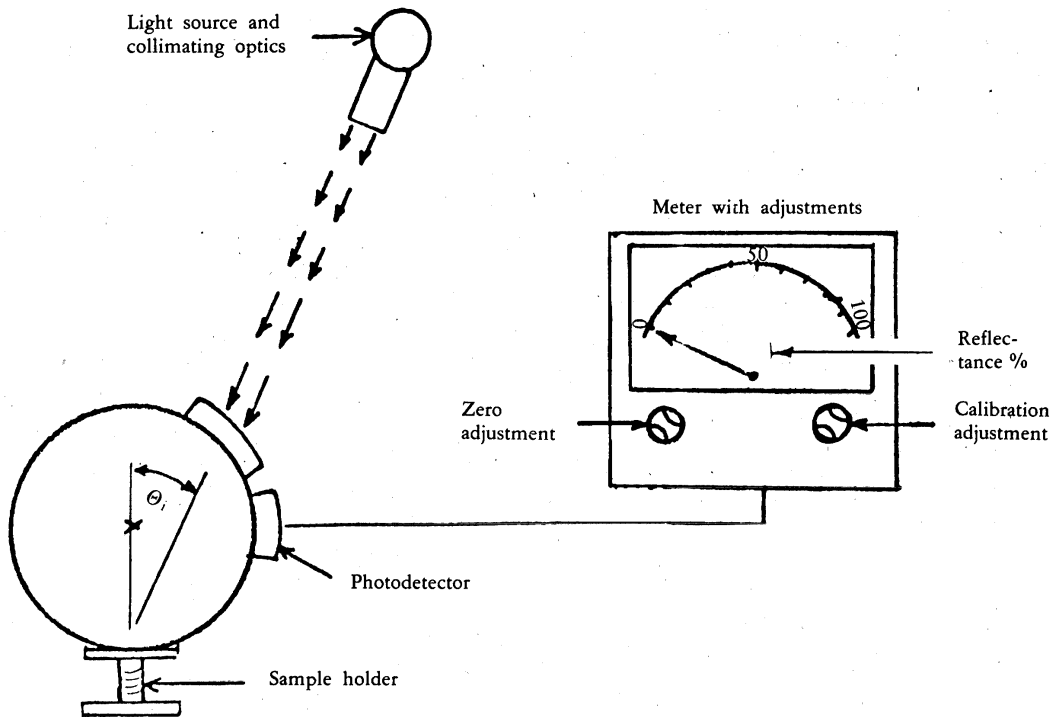

Figure 2. Generalized reflectometer incorporating an integrating sphere in the receiver

▼ M2

Spectral tristimulus values for the CIE 1931 standard colorimetric observer⁽¹⁾

This table is taken from CIE publication 50 (45) (1970)

λ nm	$\bar{x}(\lambda)$	$\bar{y}(\lambda)$	$\bar{z}(\lambda)$
380	0,001 4	0,000 0	0,006 5
390	0,004 2	0,000 1	0,020 1
400	0,014 3	0,000 4	0,067 9
410	0,043 5	0,001 2	0,207 4
420	0,134 4	0,004 0	0,645 6
430	0,283 9	0,011 6	1,385 6
440	0,348 3	0,023 0	1,747 1
450	0,336 2	0,038 0	1,772 1
460	0,290 8	0,060 0	1,669 2
470	0,195 4	0,091 0	1,287 6
480	0,095 6	0,139 0	0,813 0
490	0,032 0	0,208 0	0,465 2
500	0,004 9	0,323 0	0,272 0
510	0,009 3	0,503 0	0,158 2
520	0,063 3	0,710 0	0,078 2
530	0,165 5	0,862 0	0,042 2
540	0,290 4	0,954 0	0,020 3
550	0,433 4	0,995 0	0,008 7
560	0,594 5	0,995 0	0,003 9
570	0,762 1	0,952 0	0,002 1
580	0,916 3	0,870 0	0,001 7
590	1,026 3	0,757 0	0,001 1
600	1,062 2	0,631 0	0,000 8
610	1,002 6	0,503 0	0,000 3
621	0,854 4	0,381 0	0,000 2
630	0,642 4	0,265 0	0,000 0
640	0,447 9	0,175 0	0,000 0
650	0,283 5	0,107 0	0,000 0
660	0,164 9	0,061 0	0,000 0
670	0,087 4	0,032 0	0,000 0
680	0,046 8	0,017 0	0,000 0
690	0,022 7	0,008 2	0,000 0
700	0,011 4	0,004 1	0,000 0
710	0,005 8	0,002 1	0,000 0
720	0,002 9	0,001 0	0,000 0
730	0,001 4	0,000 5	0,000 0
740	0,000 7	0,000 2 ⁽²⁾	0,000 0
750	0,000 3	0,000 1	0,000 0
760	0,000 2	0,000 1	0,000 0
770	0,000 1	0,000 0	0,000 0
780	0,000 0	0,000 0	0,000 0

⁽¹⁾ Abridged table. The values of $\bar{y}(\lambda) = V(\lambda)$ are rounded off to four decimal places.⁽²⁾ Changed in 1966 from 3 to 2.

▼ **M2***Appendix 2 to Annex II***CONDITIONS GOVERNING THE EEC COMPONENT TYPE-APPROVAL AND MARKING OF REAR-VIEW MIRRORS**

1. APPLICATION FOR EEC COMPONENT TYPE-APPROVAL
 - 1.1. Application for EEC component type-approval for a type of rear-view mirror shall be made by the holder of the trade mark or name, or by his authorized representative.
 - 1.2. For each type of rear-view mirror the application shall be accompanied by:
 - 1.2.1. a technical description, specifying in particular the type(s) of vehicle for which the rear-view mirror is intended;
 - 1.2.2. sufficiently detailed drawings for identification of the rear-view mirror, together with instructions for mounting: the drawings must show the proposed position of the component type-approval number and the additional symbol in relation to the rectangle which forms part of the EEC component type-approval mark;
 - 1.2.3. four rear-view mirrors: three for use in the tests and one to be retained by the laboratory for any further examination that might subsequently prove necessary. Additional specimens may be called for at the request of the laboratory.
2. INSCRIPTIONS

Specimens of a type of rear-view mirror submitted for EEC component type-approval must bear the applicant's clearly visible and indelible trade mark or name and must allow sufficient space for the inscription of the EEC component type-approval mark; this space must be indicated in the diagrams referred to in item 1.2.2.
3. EEC COMPONENT TYPE-APPROVAL
 - 3.1. EEC component type-approval shall be granted and a component type-approval number issued in respect of any rear-view mirror submitted in accordance with the provisions of item 1 above which satisfies the requirements of items 1 to 5 of Annex II.
 - 3.2. This number shall not be assigned to any other type of rear-view mirror.
4. MARKING
 - 4.1. Any rear-view mirror conforming to a type in respect of which component type-approval has been granted pursuant to this Directive shall bear an EEC component type-approval mark.
 - 4.2. The EEC component type-approval mark shall consist of a rectangle surrounding the lower case letter 'e' followed by the distinguishing letter(s) or number of the Member State which has granted the component type-approval: ► **A3** (1 for Germany, 2 for France, 3 for Italy, 4 for the Netherlands, ► **A4** 5 for Sweden, ◀ 6 for Belgium, ► **A5** 7 for Hungary, 8 for the Czech Republic, ◀ 9 for Spain, 11 for the United Kingdom, ► **A4** 12 for Austria, ◀ 13 for Luxembourg, ► **A4** 17 for Finland, ◀ 18 for Denmark, ► **A5** 20 for Poland, 26 for Slovenia, 27 for Slovakia, 29 for Estonia, 32 for Latvia, 36 for Lithuania, CY for Cyprus, ◀ ► **M4** EL for Greece ◀, IRL for Ireland, ► **A5** MT for Malta, ◀ P for Portugal) ◀. It must also include in the vicinity of the rectangle the EEC component type-approval number. This number shall consist of the component type-approval number shown on the certificate completed for the type (see Appendix 3), preceded by two figures indicating the sequence number of the latest amendment to Council Directive 71/127/EEC on the date EEC component type-approval was granted. The amendment sequence number and the component type-approval number shown on the certificate shall be separated by an asterisk. In this Directive the sequence number is 02. ► **M3** Sequence number 01 may, however, be retained for Class I, II and III rear-view mirrors if the requirements relating to these three classes of mirror remain unchanged. ◀
 - 4.3. The EEC component type-approval mark shall be completed by the addition of the symbol I or II or III or IV or V, specifying the class to which the type of rear-view mirror belongs. The additional symbol shall be

▼ M2

placed in any convenient position in the vicinity of the rectangle containing the letter 'e'.

- 4.4. The EEC component type-approval mark and the additional symbol shall be indelibly inscribed on an integral part of the rear-view mirror in such a way as to be clearly visible even after the rear-view mirror has been mounted on a vehicle.
- 4.5. Four examples of EEC component type-approval marks, completed by the additional symbol are given below.

▼ M2

Examples of EEC component type-approval marks and the additional symbol

Example No 1

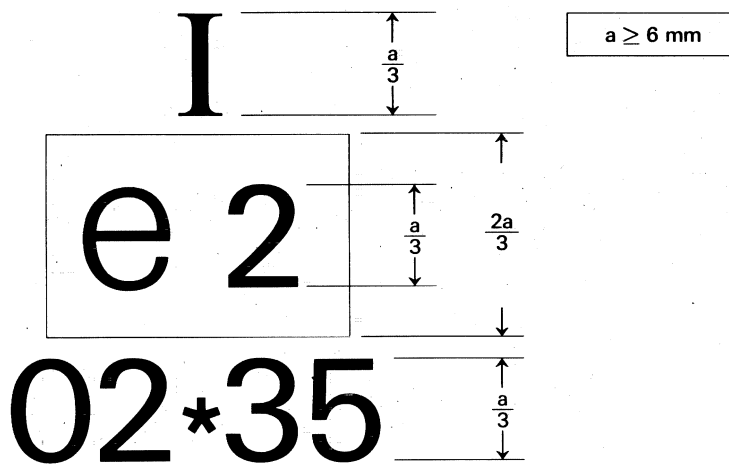

The rear-view mirror bearing the EEC component type-approval mark shown above is a Class I mirror (interior rear-view), which has been type-approved in France (e2) under the number 02 * 35.

Example No 2

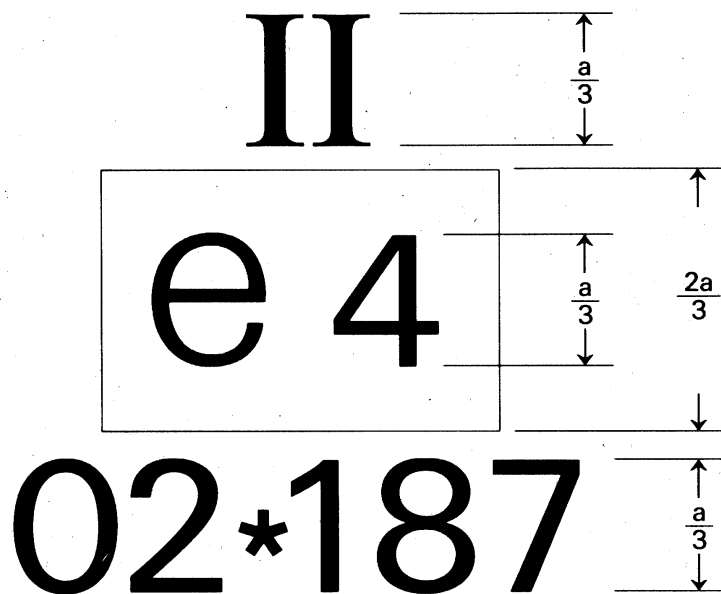

The rear-view mirror bearing the EEC component type-approval mark shown above is a Class II mirror (exterior rear-view), which has been type-approved in the Netherlands (e4) under the number 02 * 187.

▼M2

Example No 3

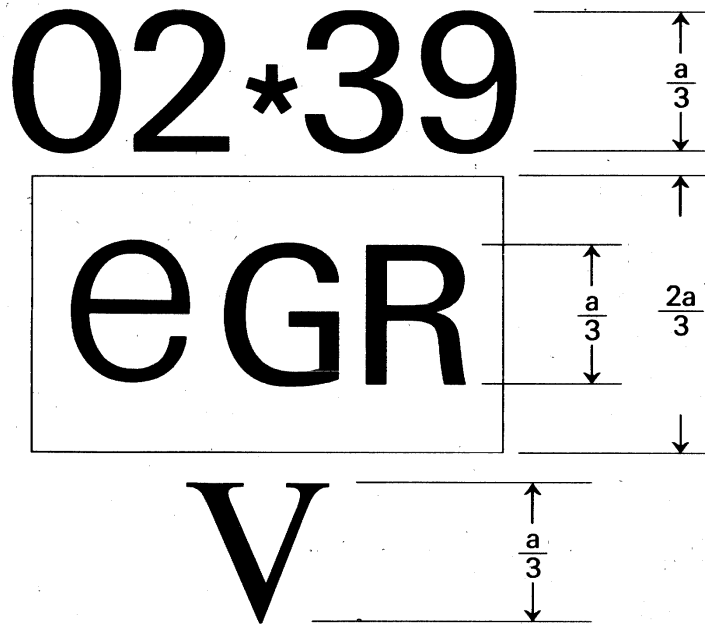

The rear-view mirror bearing the EEC component type-approval mark shown above is a Class V mirror (exterior rear-view 'reversing') which has been type-approved in Greece (eGR) under the number 02 * 39.

Example No 4

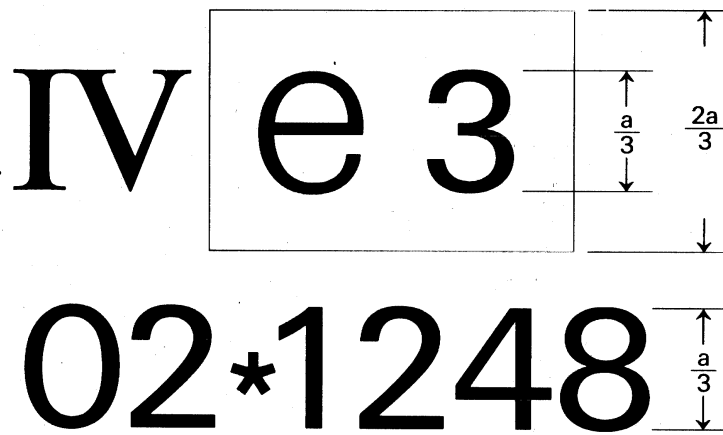

The rear-view mirror bearing the EEC component type-approval mark shown above is a Class IV mirror (exterior rear-view 'wide-angle'), which has been type-approved in Italy (e3) under the number 02 * 1248.

▼ M2

Appendix 3 to Annex II

MODEL EEC COMPONENT TYPE-APPROVAL CERTIFICATE FOR A REAR-VIEW MIRROR

Name of administration

Notification concerning the grant, refusal, withdrawal or extension of EEC component type-approval for a type of rear-view mirror

EEC component type-approval No

1. Trade name or mark

.....

2. Class (I, II, III, IV, V) (1)

3. Name and address of manufacturer

.....

4. If applicable, name and address of manufacturer's authorized representative

.....

5. Symbol Σ_m defined in item 4.1.1 of Annex II: yes/no (1)

6. Submitted for type-approval on

7. Test laboratory

.....

8. Date and number of laboratory report

9. Date of grant/refusal/withdrawal/extension of EEC component type-approval (1)

.....

10. Place

11. Date

12. The following documents, bearing the type-approval number shown above, are annexed to this type-approval certificate

.....

(Descriptive notes, drawings, diagrams and plans of the rear-view mirror)

These documents must be supplied to the competent authorities of the other Member States at their express request.

13. Remarks, if any, particularly as regards restrictions on use and/or conditions for fitting

.....

.....

.....
(Signature)

(1) Delete where inapplicable.

▼ M2*ANNEX III***REQUIREMENTS CONCERNING THE FITTING OF REAR-VIEW MIRRORS TO VEHICLES**

1. GENERAL
- 1.1. Rear-view mirrors must be fitted in such a way that the mirror does not move so as significantly to change the field of vision as measured or vibrate to an extent which would cause the driver to misinterpret the nature of the image perceived.
- 1.2. The conditions laid down in item 1.1 must be maintained when the vehicle is moving at speeds of up to 80 % of its maximum design speed, but not exceeding 150 km/h.

▼ M3

- 1.3. Vehicles having received EEC type-approval in respect of the fitting of their rear-view mirrors in pursuance of this Directive may, either fully or in part, be fitted with Class I, II or III rear-view mirrors bearing within their EEC component type-approval number sequence number 01, on condition that the requirements relating to these three classes of rear-view mirror remain unchanged.

▼ M2

2. NUMBER
- 2.1. **Minimum number of compulsory rear-view mirrors**

▼ M5

- 2.1.1. The fields of vision prescribed in point 5 shall be obtained from the minimum number of mandatory rear-view mirrors set out in the following table:

Category	External rear-view mirrors				
	Inside rear-view mirrors Class I	Main rear-view mirrors		Wide-angle rear-view mirrors Class IV	Close-proximity rear-view mirrors Class V
		Class II	Class III		
M ₁	1 (see, however, point 2.1.2)	— (see, however, point 2.1.2.3)	1 on the side opposite the direction followed by the traffic (see, however, point 2.2.1)	—	—
M ₂	—	2 (1 on the left and 1 on the right)	—	— (see, however, point 2.2.4)	— (see, however points 2.2.2 and 3.7)
M ₃	—	2 (1 on the left and 1 on the right)	—	— (see, however, point 2.2.4)	— (see, however, points 2.2.2 and 3.7)
N ₁	1 (see, however, point 2.1.2)	— (see, however, point 2.1.2.3)	1 on the side opposite the direction followed by the traffic (see, however, point 2.2.1)	— (see, however, point 2.2.4)	—
N ₂ ≤ 7,5 tonnes	— (see, however, point 2.2.3)	2 (1 on the left and 1 on the right)	— (see, however, point 2.1.3)	— (see, however, point 2.1.4)	— (see, however, points 2.2.2 and 3.7)
N ₃ > 7,5 tonnes	— (see, however, point 2.2.3)	2 (1 on the left and 1 on the right)	— (see, however, point 2.1.3)	1	— (see, however, point 3.7)

Category	External rear-view mirrors			
	Inside rear-view mirrors Class I	Main rear-view mirrors		Wide-angle rear-view mirrors Class IV
		Class II	Class III	
N ₃	— (see, however, point 2.2.3)	2 (1 on the left and 1 on the right)	— (see, however, point 2.1.3)	1 (see, however, point 3.7)

Close-proximity rear-view mirrors
Class V

▼ M2

- 2.1.2. Nevertheless, in the case of vehicles in categories M_1 and N_1 :
- 2.1.2.1. if the interior rear-view mirror does not satisfy the requirements laid down in item 5.2, a second exterior rear-view mirror must be fitted to the side of the vehicle opposite that of the compulsory rear-view mirror referred to in item 2.1.1 above;
- 2.1.2.2. if the interior rear-view mirror does not provide any rearward vision, its presence shall not be required;
- 2.1.2.3. Class II exterior rear-view mirrors are admissible.
- 2.1.3. ►M5 However, ◀ if the design ►M5, for category N_2 and N_3 vehicles ◀ makes it technically impossible to obtain the fields of vision specified in items 5.3.2.2 and 5.4 when a Class IV rear-view mirror is fitted to the same mounting as a Class II rear-view mirror, the latter may be replaced by a Class III rear-view mirror.

This derogation shall apply only until 1 October 1992.

▼ M5

- 2.1.4. A Class IV rear-view mirror is mandatory on all category N_2 vehicles having a maximum mass not exceeding 7,5 tonnes if the mandatory Class II rear-view mirror, fitted to the same side, is not convex.

▼ M2

- 2.2. **Maximum number of optional rear-view mirrors**
- 2.2.1. In the case of vehicles of category M_1 and N_1 , an exterior rear-view mirror may be fitted on the side of the vehicle opposite to that on which the compulsory exterior rear-view mirror referred to in item 2.1.1 is fitted.

▼ M5

- 2.2.2. A Class V outside rear-view mirror is acceptable for category N_2 vehicles having a maximum mass not exceeding 7,5 tonnes, and for category M_2 and M_3 vehicles.

▼ M2

- 2.2.3. An interior rear-view mirror may be fitted to vehicles in categories N_2 and N_3 .

▼ M5

- 2.2.4. A Class IV outside rear-view mirror is acceptable for N_2 vehicles having a maximum mass not exceeding 7,5 tonnes, and for category M_2 and M_3 vehicles.

▼ M2

- 2.2.5. The rear-view mirrors referred to in items 2.2.1 to 2.2.4 must satisfy the requirements of this Directive.

Nevertheless, the provisions of item 5 of this Annex shall not apply to the rear-view mirrors referred to in item 2.2.3.

- 2.2.6. The provisions of this Directive do not apply to the surveillance rear-view mirrors defined in item 4 of Annex I. Nevertheless, these rear-view mirrors must be mounted at least 2 m above the ground when the vehicle is under a load corresponding to its maximum permissible all-up weight.

3. POSITION

- 3.1. Rear-view mirrors must be so placed that the driver, when sitting on the driving seat, in a normal driving position, has a clear view of the road to the rear and side(s) of the vehicle.
- 3.2. Exterior rear-view mirrors shall be visible through the side windows or through the portion of the windscreen that is swept by the windscreen wiper. Nevertheless, for design reasons this provision shall not apply to exterior rear-view mirrors fitted on the right side of vehicles of categories M_2 and M_3 in Member States with right-hand rule of the road and on the left side of vehicles of the same categories in Member States with left-hand rule of the road.
- 3.3. In the case of any vehicle which is in chassis/cab form when the field of vision is measured, the minimum and maximum body widths shall be stated by the manufacturer and, if necessary, simulated by dummy headboards. All vehicles and mirror configurations taken into consideration during the tests shall be shown on the EEC type-approval certificate for a vehicle with regard to the installation of rear-view mirrors (see Appendix).

▼ **M2**

- 3.4. The prescribed exterior rear-view mirror on the driver's side of the vehicle must be so located that an angle of not more than 55° is formed between the vertical longitudinal median plane of the vehicle and the vertical plane passing through the centre of the rear-view mirror and through the centre of the straight line 65 mm long which joins the driver's two ocular points.
- 3.5. Rear-view mirrors must not project beyond the external bodywork of the vehicle substantially more than is necessary to comply with the requirements concerning fields of vision laid down in item 5.
- 3.6. Where the lower edge of an exterior rear-view mirror is less than 2 m above the ground when the vehicle is loaded to its maximum permissible all-up weight, this rear-view mirror must not project more than 0,20 m beyond the overall width of the vehicle measured without rear-view mirrors.
- 3.7. Class V rear-view mirrors shall be mounted on vehicles in such a way that, regardless of their position after adjustment, no part of these mirrors or their holders is less than 2 m from the ground when the vehicle is under a load corresponding to its maximum permissible all-up weight.

These rear-view mirrors shall not, however, be mounted on vehicles the cab height of which is such as to prevent compliance with this requirement.

- 3.8. Subject to the requirements of items 3.5, 3.6 and 3.7, rear-view mirrors may project beyond the permissible maximum widths of vehicles.

4. ADJUSTMENT

- 4.1. The interior rear-view mirror must be capable of being adjusted by the driver from his driving position.
- 4.2. The exterior rear-view mirror situated on the driver's side must be capable of being adjusted from inside the vehicle while the door is closed, although the window may be open. The mirror may, however, be locked in position from the outside.
- 4.3. The requirements of item 4.2 do not apply to exterior rear-view mirrors which, after having been knocked out of alignment, can be returned to their former position without the need for adjustment.

5. FIELDS OF VISION

5.1. General

The fields of vision defined below must apply in respect of ambinocular vision, the eyes being at the 'driver's ocular points' as defined in item 12 of Annex I above. The fields of vision shall be determined when the vehicle is in running order as defined in item 2.6 of Annex I to Directive 70/156/EEC and is carrying in addition one front-seat passenger, the mass of the passenger being 75 kilograms \pm 1 %. They must be established through windows which have a total light transmission factor of at least 70 % measured perpendicularly to the surface.

5.2. Interior rear-view mirror (Class I)

The field of vision must be such that the driver can see at least a 20-m-wide, flat, horizontal portion of the road centred on the vertical longitudinal median plane of the vehicle and extending from 60 m behind the driver's ocular points (Figure 3) to the horizon.

5.3. Main exterior rear-view mirrors (Classes II and III)

- 5.3.1. *Left-hand exterior rear-view mirror for vehicles driven on the right of the road and right-hand exterior rear-view mirror for vehicles driven on the left of the road*
- 5.3.1.1. The field of vision must be such that the driver can see at least a 2,50-m-wide, flat, horizontal portion of the road, which is bounded on the right (in the case of vehicles driven on the right), or on the left (in the case of vehicles driven on the left) by the plane which is parallel to the median longitudinal vertical plane passing through the outermost point of the vehicle on the left (in the case of vehicles driven on the right), or on the right (in the case of vehicles driven on the left) and extends from 10 m behind the driver's ocular points to the horizon (Figures 4 and 5).

▼ **M2**5.3.2. *Right-hand exterior rear-view mirror for vehicles driven on the right and left-hand exterior rear-view mirror for vehicles driven on the left*

5.3.2.1. In the case of category M₁ vehicles and category N₁ vehicles having a maximum weight not exceeding 2 tonnes, the field of vision must be such that the driver can see at least a 4-m-wide flat, horizontal portion of the road which is bounded on the left (in the case of vehicles driven on the right), or on the right (in the case of vehicles driven on the left) by a plane parallel to the median longitudinal vertical plane passing through the outermost point of the vehicle on the right (in the case of vehicles driven on the right) or on the left (in the case of vehicles driven on the left) and which extends from 20 m behind the driver's ocular points to the horizon (see Figure 4).

5.3.2.2. In the case of vehicles other than those referred to in item 5.3.2.1 above, the field of vision must be such that the driver can see at least a 3,50-m-wide, flat, horizontal portion of the road, which is bounded on the left (in the case of vehicles driven on the right), or on the right (in the case of vehicles driven on the left) by a plane parallel to the median longitudinal vertical plane of the vehicle and passing through the outermost point of the vehicle on the right (in the case of vehicles driven on the right) or on the left (in the case of vehicles driven on the left) and which extends from 30 m behind the driver's ocular points to the horizon.

In addition, the road must be visible to the driver over a width of 0,75 m, from a point 4 m behind the vertical plane passing through the driver's ocular points (Figure 5).

5.4. **'Wide-angle' exterior rear-view mirror (Class IV)**

5.4.1. The field of vision must be such that the driver can see at least a 12,50-m-wide, flat, horizontal portion of the road, which is bounded on the left (in the case of vehicles driven on the right), or on the right (in the case of vehicles driven on the left) by a plane parallel to the median longitudinal vertical plane of the vehicle and passing through the outermost point of the vehicle on the right (in the case of vehicles driven on the right) or on the left (in the case of vehicles driven on the left) and which extends from at least 15 m to 25 m behind the driver's ocular points. In addition, the road must be visible to the driver over a width of 2,5 m, from a point 3 m behind the vertical plane passing through the driver's ocular points (see Figure 6).

5.5. **'Close-proximity' exterior rear-view mirror (Class V)**

The field of vision must be such that the driver can see a flat horizontal portion of the road along the side of the vehicle, bounded by the following vertical planes (see Figures 7a and 7b):

5.5.1. the plane parallel to the median longitudinal vertical plane of the vehicle which passes through a point 0,2 m beyond the outermost point of the vehicle cab on the right ► **M5** (for left-hand drive vehicles) ◀ or on the left ► **M5** (for right-hand drive vehicles) ◀;

5.5.2. in the transverse direction, the parallel plane passing at a distance of 1 m in front of the plane mentioned in item 5.5.1;

5.5.3. to the rear, the plane parallel to the vertical plane passing through the driver's ocular points and situated at a distance of 1,25 m behind that plane;

5.5.4. to the front, the plane parallel to the vertical plane passing through the driver's ocular points and situated at a distance of 1 m in front of that plane. If the vertical transverse plane passing through the leading edge of the vehicle bumper is less than 1 m in front of the vertical plane passing through the driver's ocular points, the field of vision shall be limited to that plane (see Figure 7b).

5.6. In the case of rear-view mirrors consisting of several reflecting surfaces which are either of different curvature or make an angle with each other, at least one of the reflecting surfaces must provide the field of vision and have the dimensions (see item 2.2.2 of Annex II) specified for the class to which they belong.

5.7. **Obstructions**5.7.1. *Interior rear-view mirror (Class I)*

5.7.1.1. A reduction in the field of vision due to the presence of devices such as head-restraints, sun-visors, rear window wipers and heating elements is

▼ M2

permissible, provided that all these devices together do not obscure more than 15 % of the specified field of vision.

5.7.1.2. The degree of obstruction is measured with the headrests adjusted to their lowest possible position and with the sun-visors folded back.

5.7.2. *Exterior rear-view mirrors (Classes II, III, IV and V)*

In the fields of vision specified above, obstruction due to the bodywork and some of its components, such as door handles, outline marker lights, direction indicators and the extremities of rear bumpers, as well as reflective-surface cleaning components, shall not be taken into account if they are responsible for a total obstruction of less than 10 % of the specified field of vision.

5.8. **Test procedure**

The field of vision shall be determined by placing powerful light sources at the ocular points and examining the light reflected on the vertical monitoring screen. Other, equivalent, methods may be used.

▼ M2

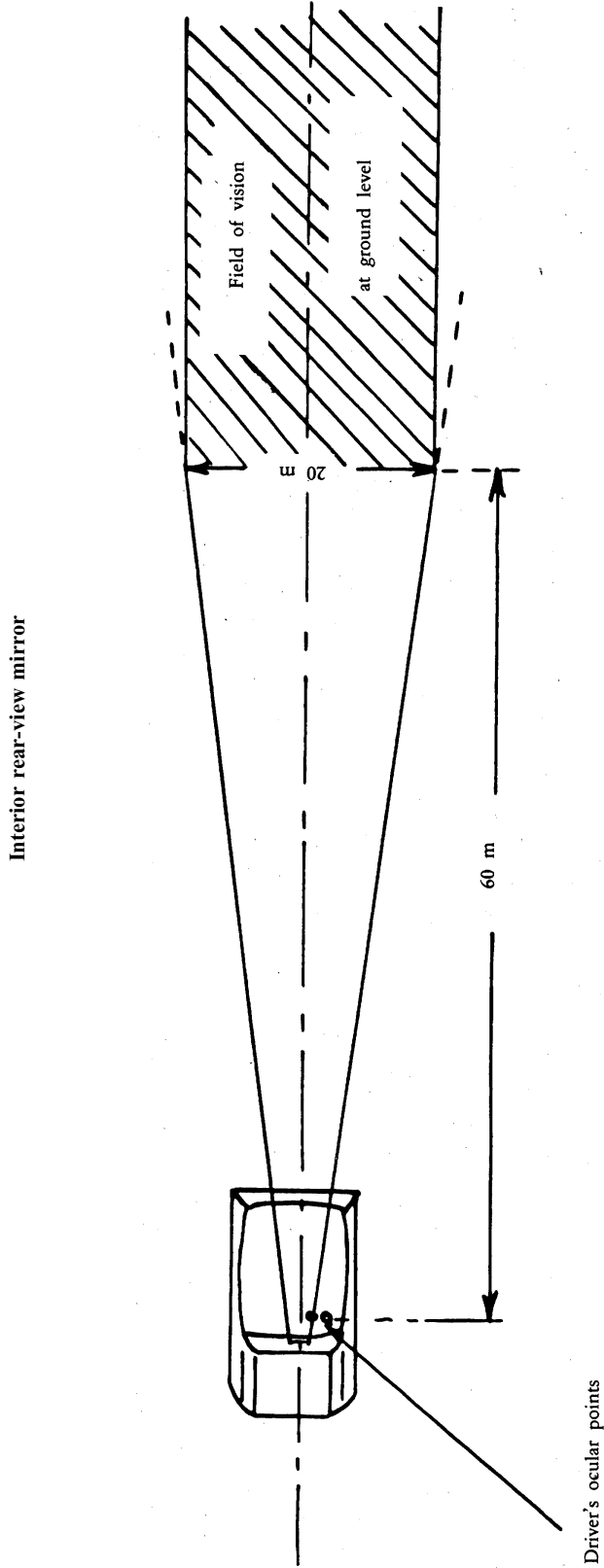

Figure 3

▼ **M2**

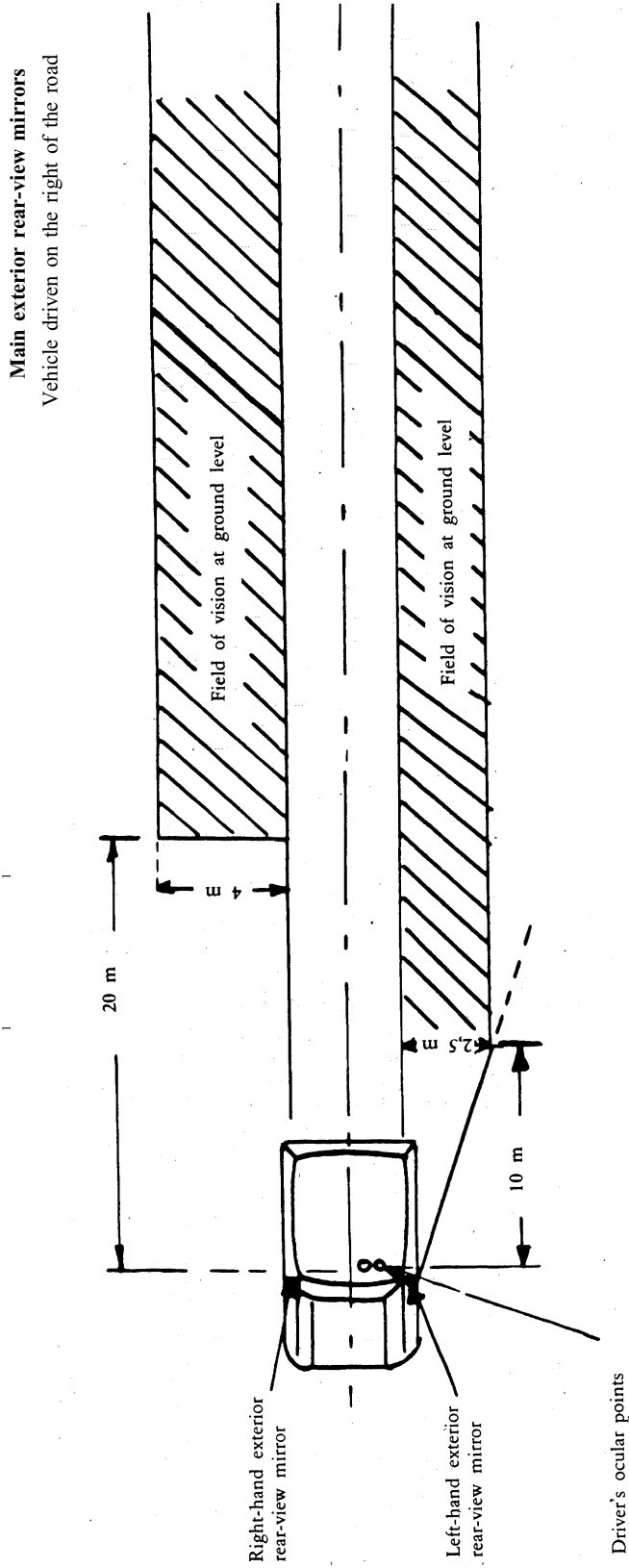

Figure 4

Vehicle category M and category N not exceeding 2 tonnes in weight

▼ M2

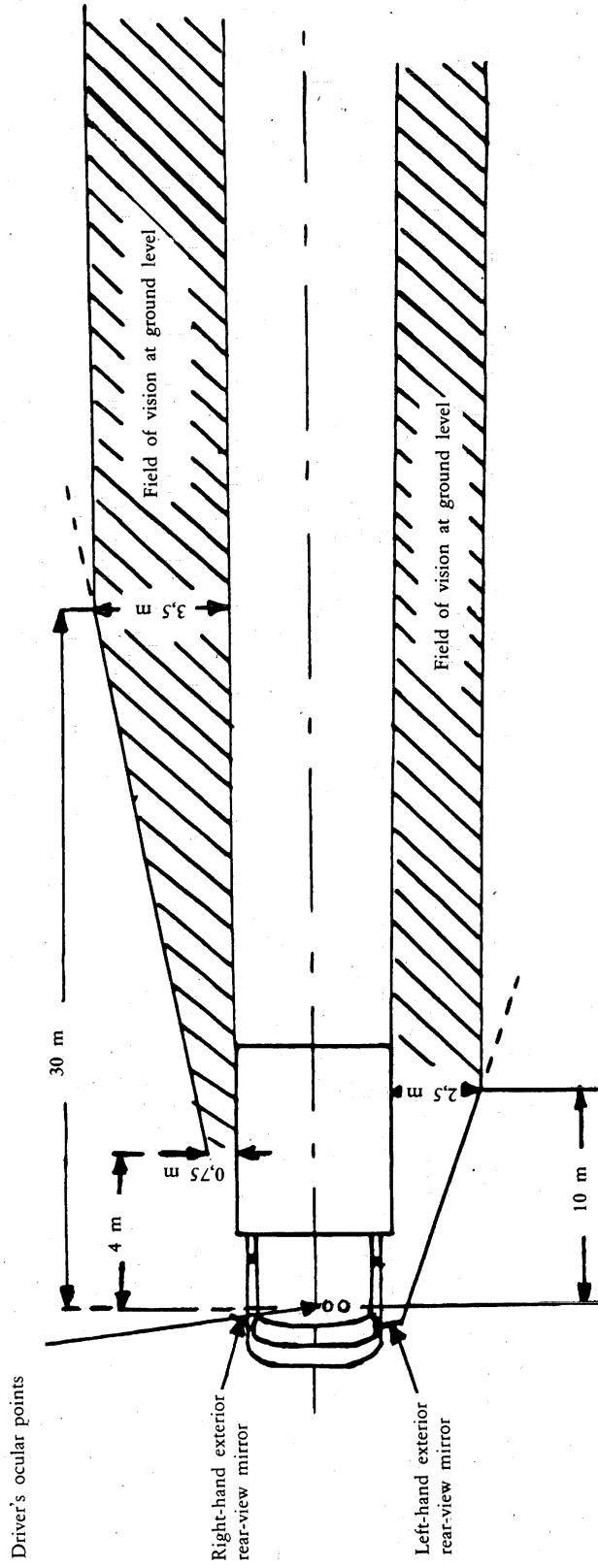

Figure 5

Vehicles in categories other than M and N not exceeding 2 tonnes in weight

▼M2

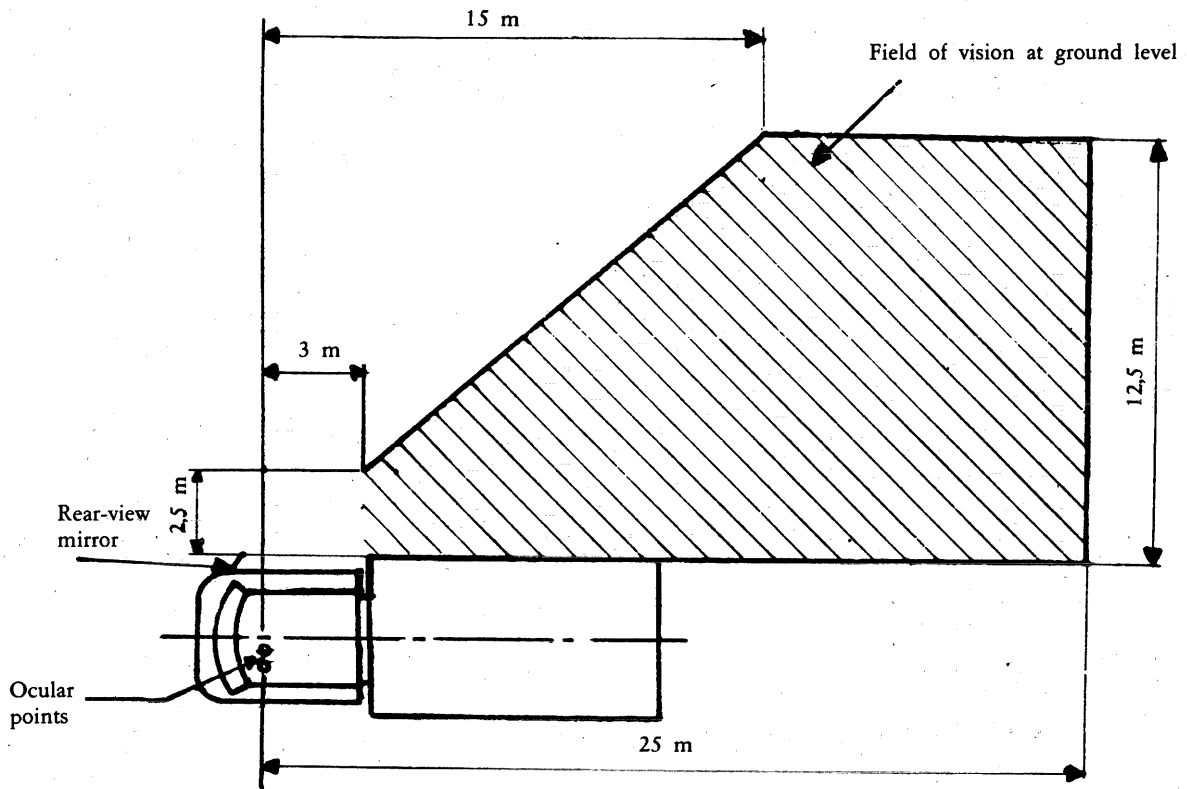

Figure 6
Wide-angle rear-view mirror

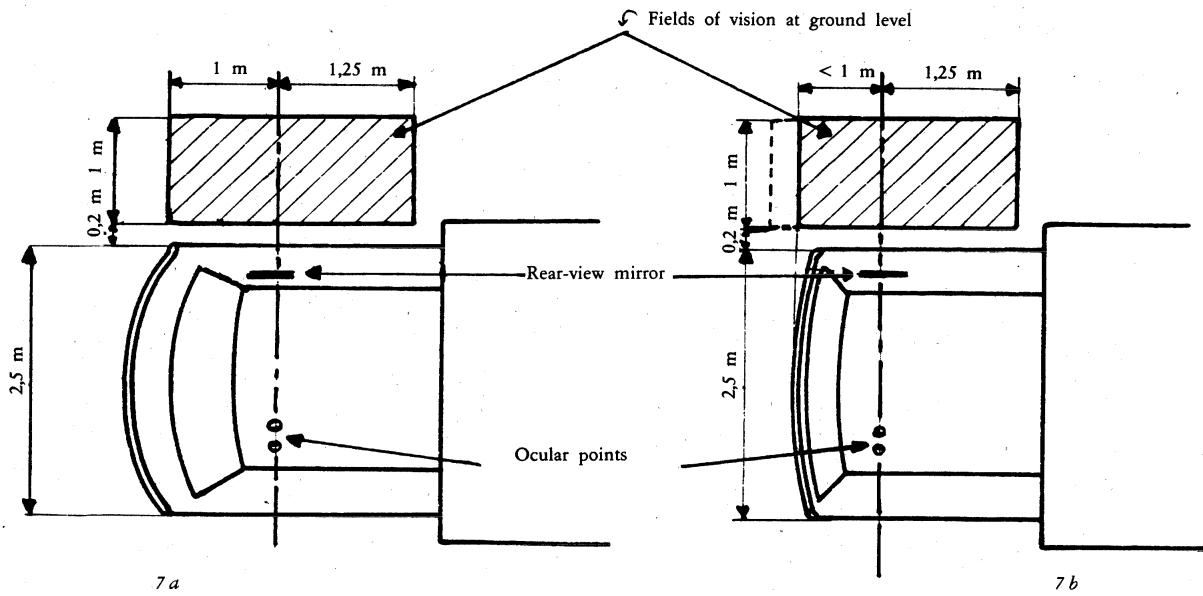

Figure 7
'Close-proximity' exterior rear-view mirror

▼M2

Appendix to Annex III

ANNEX TO THE EEC TYPE-APPROVAL CERTIFICATE FOR A VEHICLE WITH REGARD TO THE INSTALLATION OF REAR-VIEW MIRRORS

(Articles 4 (2) and 10 of Council Directive 70/156/EEC of 6 February 1970 on the approximation of the laws of the Member States relating to the type-approval of motor vehicles and their trailers)

Name of administration

- EEC type-approval No
- extension (1)
1. Trade name or mark of vehicle
 2. Type of vehicle
 3. Category of vehicle (M₁, M₂, M₃, N₁ ≤ 2 t, N₁, N₂, N₃) (2)
 - 3.1. Type of category N₃ vehicle : rigid lorry/trailer/semi-trailer (2)
 4. Name and address of vehicle manufacturer
 5. If applicable, name and address of authorized representative
 6. Trade name or mark of rear-view mirrors and component type-approval number
 7. Class(es) of rear-view mirror (I, II, III, IV, V) (2)
 8. The derogation (applicable until 1 October 1992) in respect of the fitting of a Class II and a Class IV rear-view mirror on the same mounting on category N₃ vehicles (in the case referred to in item 2.1.3 of Annex III) is granted/refused (2).
 9. Extension of EEC type-approval of the vehicle to cover the following rear-view mirror type
 10. Date for identification of the R point of the driver's seating position
 11. Maximum and minimum bodywork widths in respect of which the rear-view mirror has been granted type-approval (in the case of chassis/cabs referred to in item 3.3 of Annex III)

(1) Where appropriate, state whether the extension of the initial EEC type-approval is the first, second, etc.

(2) Delete where inapplicable.

▼ M2

12. Vehicle submitted for EEC type-approval on
13. Technical department responsible for checking conformity for the purpose of EEC type-approval
14. Date of report issued by that department
15. Number of report issued by that department
16. EEC type-approval in respect of the installation of rear-view mirrors has been granted/refused (!)
17. An extension of EEC type-approval in respect of the installation of rear-view mirrors has been granted/refused (!)
18. Place
19. Date
20. Signature
21. The following documents, bearing the type-approval number shown above, are annexed to this certificate :
 - drawings showing the mountings of the rear-view mirrors ;
 - drawings and plans showing the mounting positions and the characteristics of the part of the structure where the rear-view mirrors are mounted ;
 - general view from the front, the rear and the passenger compartment showing where the rear-view mirrors are fitted.

These documents must be supplied to the competent authorities of the other Member States at their express request.

(!) Delete where inapplicable.