

Commission Decision (EU) 2016/1756 of 28 September 2016 determining the European Union position with regard to a decision of the management entities under the Agreement between the Government of the United States of America and the European Union on the coordination of energy-efficiency labelling programmes for office equipment, on the revision of specifications for displays included in Annex C to the Agreement (Text with EEA relevance)

ANNEX II

ANNEX C

PART II TO THE AGREEMENT

I. DISPLAY SPECIFICATIONS (Version 7.0)

1. **Definitions**

(A) Product Types:

(1) Electronic Display (Display) : A product with a display screen and associated electronics, often encased in a single housing, that as its primary function produces visual information from (1) a computer, workstation, or server via one or more inputs (e.g. VGA, DVI, HDMI, DisplayPort, IEEE 1394, USB), (2) external storage (e.g. USB flash drive, memory card), or (3) a network connection.

(a) Monitor : An Electronic Display intended for one person to view in a desk-based environment.

(b) Signage Display : An Electronic Display intended for multiple people to view in non-desk-based environments, such as retail or department stores, restaurants, museums, hotels, outdoor venues, airports, conference rooms or classrooms. For the purposes of this specification, a Display shall be classified as a Signage Display if it meets two or more criteria listed below:

(1) Diagonal screen size is greater than 30 inches;

(2) Maximum Reported Luminance is greater than 400 candelas per square metre;

(3) Pixel density is less than or equal to 5 000 pixels per square inch; or

(4) Ships without a mounting stand.

(B) Operational Modes:

- (1) On Mode : The mode in which the Display has been activated, and is providing the primary function.
- (2) Sleep Mode : A low-power mode in which the Display provides one or more non-primary protective functions or continuous functions.

Note: Sleep Mode may serve the following functions: facilitate the activation of On Mode via remote switch, Touch Technology, internal sensor, or timer; provide information or status displays including clocks; support sensor-based functions; or maintain a network presence.

- (3) Off Mode : The mode where the Display is connected to a power source, produces no visual information, and cannot be switched into any other mode with the remote control unit, an internal signal, or an external signal.

Note: The Display may only exit this mode by direct user actuation of an integrated power switch or control. Some products may not have an Off Mode.

(C) Visual Characteristics:

- (1) Ambient Light Conditions : The combination of light illuminances in the environment surrounding a Display, such as a living room or an office.

- (2) Automatic Brightness Control (ABC) : The self-acting mechanism that controls the brightness of a Display as a function of Ambient Light Conditions.
Note: ABC functionality must be enabled to control the brightness of a Display.

- (3) Colour Gamut : Colour gamut area shall be reported as a percentage of the CIE LUV 1976 u' v' colour space and calculated as per Section 5.18 Gamut Area of the Information Display Measurements Standard Version 1.03.

Note: Any gamut support in non-visible/invisible colour areas is not to be counted. The gamut's size must be expressed as a percentage of area of the visible CIE LUV colour space only.

- (4) Luminance : The photometric measure of the luminous intensity per unit area of light travelling in a given direction, expressed in candelas per square metre (cd/m^2).

- (a) : The maximum luminance the Maximum Display may attain at an On Reported Mode preset setting, and as Luminance specified by the manufacturer, for example, in the user manual.

- (b) : The maximum measured Maximum luminance the Display may attain by manually configuring

Status: This is the original version (as it was originally adopted).

- Measured Luminance (c) : Measured its controls, such as brightness and contrast. The luminance of the Display at the factory default preset setting the manufacturer selects for normal home or applicable market use.
- As-shipped Luminance : The luminance of the Display at the factory default preset setting the manufacturer selects for normal home or applicable market use.
- (5) Native Vertical Resolution : The number of physical lines along the vertical axis of the Display within the visible area of the Display.
Note: A Display with a screen resolution of 1 920 × 1 080 (horizontal × vertical) would have a Native Vertical Resolution of 1 080.
- (6) Screen Area : The visible area of the Display that produces images.
Note: Screen Area is calculated by multiplying the viewable image width by the viewable image height. For curved screens, measure the width and height along the arc of the Display.
- (D) Additional Functions and Features:
- (1) Bridge Connection : A physical connection between two hub controllers (i.e. USB, FireWire).
Note: Bridge Connections allow for expansion of ports typically for the purpose of relocating the ports to a more convenient location or increasing the number of available ports.
- (2) Full Network Connectivity : The ability of the Display to maintain network presence while in Sleep Mode. Presence of the Display, its network services, and its applications, is maintained even if some components of the Display are powered down. The Display can elect to change power states based on receipt of network data from remote network devices, but should otherwise stay in Sleep Mode absent a demand for services from a remote network device.
Note: Full Network Connectivity is not limited to a specific set of protocols. Also referred to as ‘network proxy’ functionality and described in the Ecma-393 standard.
- (3) Occupancy Sensor : A device used to detect human presence in front of or in the area surrounding a Display.
Note: An Occupancy Sensor is typically used to switch a Display between On Mode and Sleep Mode.
- (4) Touch Technology : Enables the user to interact with a product by touching areas on the Display screen.
- (5) Plug-in Module : A modular plugin device that provides one or more of the following functions without the explicit purpose of providing general computing function:

- (a) Display images, mirror remote content streamed to it, or otherwise render content on the screen from local or remote sources; or
- (b) Process touch signals.

Note: Modules providing any other additional input options are not considered Plug-in Modules for the purposes of this specification.

(E) **Product Family:** A group of product models that: (1) are made by the same manufacturer; (2) share the same Screen Area, Resolution, and Maximum Reported Luminance; and (3) are of a common basic screen design. Models within a Product Family may differ from each other according to one or more characteristics or features. For Displays, acceptable variations within a Product Family include:

- (1) External housing;
- (2) Number and types of interfaces;
- (3) Number and types of data, network, or peripheral ports; and
- (4) Processing and memory capability.

(F) **Representative Model:** The product configuration that is tested for Energy Star qualification and is intended to be marketed and labelled as ENERGY STAR.

(G) **Power Source**

- (1) External Power Supply (EPS) : An external power supply circuit that is used to convert household electric current into DC current or lower-voltage AC current to operate a consumer product.
- (2) Standard DC : A method for transmitting DC power defined by a well-known technology standard, enabling plug-and-play interoperability.

Note: Common examples are USB and Power-over-Ethernet. Usually Standard DC includes both power and communications over the same cable, but as with the 380 V DC standard, that is not required.

2. **Scope**

2.1. **Included products**

2.1.1. Products that meet the definition of a Display as specified herein and are powered directly from AC mains, an External Power Supply, or Standard DC are eligible for Energy Star qualification, with the exception of products listed in Section 2.2. Typical products that would be eligible for qualification under this specification include:

- (i) Monitors;
- (ii) Monitors with keyboard, video, and mouse (KVM) switch functionality;
- (iii) Signage Displays; and

- (iv) Signage Displays and Monitors with Plug-in Modules.
- 2.2. Excluded products
- 2.2.1. Products that are covered under other Energy Star product specifications are not eligible for qualification under this specification including Televisions and Computers (Thin Clients, Slates/Tablets, Portable All-in-one Computers, Integrated Desktops). The list of specifications currently in effect can be found at <http://www.eu-energystar.org/specifications.htm>
- 2.2.2. The following products are not eligible for qualification under this specification:
- (i) Products with an integrated television tuner;
 - (ii) Displays with integrated or replaceable batteries designed to support primary operation without AC mains or external DC power, or device mobility (e.g. electronic readers, battery-powered digital picture frames); and
 - (iii) Products that must meet EU regulations for medical devices that prohibit power management capabilities and/or do not have a power state meeting the definition of Sleep Mode.
3. **Qualification criteria**
- 3.1. Significant digits and rounding
- 3.1.1. All calculations shall be carried out with directly measured (unrounded) values.
- 3.1.2. Unless otherwise specified, compliance with specification requirements shall be evaluated using directly measured or calculated values without any benefit from rounding.
- 3.1.3. Directly measured or calculated values that are submitted for reporting to the European Commission shall be rounded to the nearest significant digit as expressed in the corresponding specification requirements.
- 3.2. General requirements for Monitors and Signage Displays
- 3.2.1. External power supplies (EPSs): Single- and Multiple-voltage EPSs shall meet the Level VI or higher performance requirements under the International Efficiency Marking Protocol when tested according to the Uniform Test Method for Measuring the Energy Consumption of External Power Supplies, Appendix Z to 10 CFR Part 430.
- (i) Single- and Multiple-voltage EPSs shall include the Level VI or higher marking.
 - (ii) Additional information on the Marking Protocol is available at <http://www.regulations.gov/#!documentDetail;D=EERE-2008-BT-STD-0005-0218>
- 3.2.2. Power management:
- (i) Products shall offer at least one power management feature that is enabled by default, and that can be used to automatically transition from Sleep Mode to On Mode either by a connected host device or internally (e.g. support for VESA Display Power Management Signalling (DPMS), enabled by default).
 - (ii) Products that generate content for display from one or more internal sources shall have a sensor or timer enabled by default to automatically engage Sleep or Off Mode.

- (iii) For products that have an internal default delay time after which the product transitions from On Mode to Sleep Mode or Off Mode, the delay time shall be reported.
- (iv) Monitors shall automatically enter Sleep Mode or Off Mode within 5 minutes of being disconnected from a host computer.
- 3.2.3. Signage Displays shall have a true power factor in On Mode of 0,7 or greater as per Section 5.2(F) in the Energy Star Test Method.
- 3.3. Energy requirements for computer monitors
- 3.3.1. The Total Energy Consumption (TEC) in kWh shall be calculated as per Equation 1 based on measured values.

Equation Total Energy Consumption Calculation

1

$$E_{TEC} = 8,76 \times (0,35 \times P_{ON} + 0,65 \times P_{SLEEP})$$

Where:

- E_{TEC} is the Total Energy Consumption calculation in kWh,
- P_{ON} is Measured On Mode Power in watts,
- P_{SLEEP} is Measured Sleep Mode Power in watts, and
- The result shall be rounded to the nearest tenth of a kWh for reporting.

- 3.3.2. The Maximum TEC (E_{TEC_MAX}) in kWh for Monitors shall be calculated as per Table 1.

TABLE 1

Calculation of Maximum TEC (E_{TEC_MAX}) for Monitors in kWh

Area (in ²)	E_{TEC} Max (kWh) Where: A Viewable screen area in in ² r Screen resolution in megapixels The result shall be rounded to the nearest tenth of a kWh for reporting
$A < 130$	$(6,13 \times r) + (0,06 \times A) + 9$
$130 \leq A < 150$	$(6,13 \times r) + (0,69 \times A) - 72,38$
$150 \leq A < 180$	$(6,13 \times r) + (0,21 \times A) - 0,50$
$180 \leq A < 200$	$(6,13 \times r) + (0,05 \times A) + 28$
$200 \leq A < 230$	$(6,13 \times r) + (0,03 \times A) + 31,33$
$230 \leq A < 280$	$(6,13 \times r) + (0,2 \times A) - 7$
$280 \leq A < 300$	$(6,13 \times r) + 49$
$300 \leq A < 500$	$(6,13 \times r) + (0,2 \times A) - 11$
$A \geq 500$	$(6,13 \times r) + 89$

- 3.3.3. For all Monitors, Calculated TEC (E_{TEC}) in kWh shall be less than or equal to the calculation of Maximum TEC (E_{TEC_MAX}) with the applicable allowances and adjustments (applied at most once) as per Equation 2.

Equation Total Energy Consumption Requirement for Monitors

2

$$E_{TEC} \leq (E_{TEC_MAX} + E_{EP} + E_{ABC} + E_N + E_{OS} + E_T) \times eff_{AC_DC}$$

Where:

- E_{TEC} is TEC in kWh calculated as per Equation 1,
- E_{TEC_MAX} is the Maximum TEC requirement in kWh calculated as per Table 1,
- E_{EP} is the enhanced performance display allowance in kWh as per Section 3.3.4,
- E_{ABC} is the Automatic Brightness Control allowance in kWh as per Equation 4,
- E_N is the Full Network Connectivity allowance in kWh as per Table 3,
- E_{OS} is the Occupancy Sensor allowance in kWh as per Table 4,
- E_T is the Touch Technology allowance in kWh as per Equation 5, and
- eff_{AC_DC} is the standard adjustment for AC-DC power conversion losses that occur at the device powering the Display, and is 1,0 for AC-powered Displays and 0,85 for Displays with Standard DC.

3.3.4. For Monitors meeting the enhanced performance display (EPD) requirements below, only one of the following Table 2 allowances shall be used in Equation 2:

- (i) Contrast ratio of at least 60:1 measured at a horizontal viewing angle of at least 85° from the perpendicular on a flat screen and at least 83° from the perpendicular on a curved screen, with or without a screen cover glass;
- (ii) A native resolution greater than or equal to 2,3 megapixels (MP); and
- (iii) Colour Gamut greater than or equal to 32,9 % of CIE LUV.

TABLE 2

Calculation of Energy Allowance for Enhanced Performance Displays

Colour Gamut Criteria	E_{EP} (kWh) Where: E_{TEC_MAX} is the Maximum TEC requirement in kWh, and r is screen resolution in megapixels
Colour Gamut support is 32,9 % of CIE LUV or greater.	$0,15 \times (E_{TEC_MAX} - 6,13 \times r)$
Colour Gamut support is 38,4 % of CIE LUV or greater.	$0,65 \times (E_{TEC_MAX} - 6,13 \times r)$

Note: A model supporting greater than 99 % of the sRGB colour space translates to 32,9 % of CIE LUV and a model supporting greater than 99 % of Adobe RGB translates to 38,4 % of CIE LUV.

3.3.5. For monitors with Automatic Brightness Control (ABC) enabled by default, an energy allowance (E_{ABC}), as calculated per Equation 4, shall be added to E_{TEC_MAX} in Equation 2, if the On Mode power reduction (R_{ABC}), as calculated per Equation 3, is greater than or equal to 20 %.

Equation Calculation of On Mode Reduction with ABC Enabled by Default

3

$$R_{ABC} = 100 \% \times \left(\frac{P_{300} - P_{12}}{P_{300}} \right)$$

Where:

- R_{ABC} is the On Mode percent power reduction due to ABC,
- P_{300} is the On Mode power in watts, as measured at an ambient light level of 300 lux in Section 6.4 of the Test Method, and
- P_{12} is the On Mode power in watts, as measured at an ambient light level of 12 lux in Section 6.4 of the Test Method.

Equation **Monitor ABC Energy Allowance (E_{ABC}) for Monitors**

4

$$E_{ABC} = 0,05 \times E_{TEC_MAX}$$

Where:

- E_{ABC} is the energy allowance for Automatic Brightness Control in kWh, and
 - E_{TEC_MAX} is the Maximum TEC in kWh, as per Table 1.
- 3.3.6. Products with Full Network Connectivity confirmed in Section 6.7 of the Energy Star Test Method shall apply the allowance specified in Table 3.

Table 3 **Full Network Connectivity Energy Allowance (E_N) for Monitors**

E_N (kWh)

2,9

- 3.3.7. Products tested with an Occupancy Sensor active shall apply the allowance specified in Table 4.

TABLE 4

Additional Functions Energy Allowance (E_{OS}) for Monitors

Type	Allowance (kWh)
Occupancy Sensor E_{OS}	1,7

- 3.3.8. Products tested with Touch Technology active in On Mode shall apply the allowance specified in Equation 5.

Equation **Energy Allowance for Touch Technology (E_T) for Monitors**

5

$$E_T = 0,15 \times E_{TEC_MAX}$$

Where:

- E_T is the energy allowance for Touch Technology in kWh, and
 - E_{TEC_MAX} is the Maximum TEC in kWh, as per Table 1.
- 3.4. On Mode requirements for Signage Displays
- 3.4.1. The Maximum On Mode Power (P_{ON_MAX}) in watts shall be calculated as per Equation 6.

Equation **Calculation of Maximum On Mode Power (P_{ON_MAX}) in Watts for Signage Displays**

6

Status: This is the original version (as it was originally adopted).

$$P_{ON_MAX} = (4,0 \times 10^{-5} \times \# \times A) + 119 \times \tanh(0,0008 \times (A - 200,0) + 0,11) + 6$$

Where:

- P_{ON_MAX} is the Maximum On Mode Power, in watts,
- A is the Screen Area in square inches,
- $\#$ is the Maximum Measured Luminance of the Display in candelas per square metre, as measured in Section 6.2 of the test method,
- \tanh is the hyperbolic tangent function, and
- the result shall be rounded to the nearest tenth of a watt for reporting.

Equation On Mode Power Requirement for Signage Displays

7

$$P_{ON} \leq P_{ON_MAX} + P_{ABC}$$

Where:

- P_{ON} is On Mode Power in watts, as measured in Section 6.3 or 6.4 of the Test Method,
- P_{ON_MAX} is the Maximum On Mode Power in watts, as per Equation 6, and
- P_{ABC} is the On Mode power allowance for ABC in watts, as per Equation 8.

- 3.4.2. For Signage Displays with ABC enabled by default, a power allowance (P_{ABC}), as calculated per Equation 8, shall be added to P_{ON_MAX} , as calculated per Equation 6, if the On Mode power reduction (R_{ABC}), as calculated per Equation 3, is greater than or equal to 20 per cent.

Equation Calculation of On Mode Power Allowance for Signage Displays with ABC Enabled by Default

8

$$P_{ABC} = 0,05 \times P_{ON_MAX}$$

Where:

- P_{ABC} is the Measured On Mode Power allowance for ABC in watts, and
- P_{ON_MAX} is the Maximum On Mode Power requirement in watts.

3.5. Sleep Mode requirements for Signage Displays

- 3.5.1. Measured Sleep Mode Power (P_{SLEEP}) in watts shall be less than or equal to the sum of the Maximum Sleep Mode Power Requirement (P_{SLEEP_MAX}) and any allowances (applied at most once) as per Equation 9.

Equation Sleep Mode Power Requirement for Signage Displays

9

$$P_{SLEEP} \leq P_{SLEEP_MAX} + P_N + P_{OS} + P_T$$

Where:

- P_{SLEEP} is Measured Sleep Mode Power in watts,
- P_{SLEEP_MAX} is the Maximum Sleep Mode Power requirement in watts as per Table 5,
- P_N is the Full Network Connectivity allowance in watts as per Table 6,
- P_{OS} is the Occupancy Sensor allowance in watts as per Table 7, and
- P_T is the Touch allowance in watts as per Table 7.

Table 5 Maximum Sleep Mode Power Requirement (P_{SLEEP_MAX}) for Signage Displays

$P_{\text{SLEEP_MAX}}$

(watts)

0,5

- 3.5.2. Products with Full Network Connectivity confirmed in Section 6.7 of the Energy Star Test Method shall apply the allowance specified in Table 6.

Table 6 Full Network Connectivity Allowance for Signage Displays

 P_{N}

(watts)

3,0

- 3.5.3. Products tested with an Occupancy Sensor or Touch Technology active in Sleep Mode shall apply the allowances specified in Table 7.

TABLE 7

Additional Functions Sleep Mode Power Allowance for Signage Displays

Type	Screen Size(in)	Allowance (watts)
Occupancy Sensor P_{OS}	All	0,3
Touch Functionality P_{T} (applicable only to Signage Displays where screen size is greater than 30 inches)	≤ 30	0,0
	> 30	1,5

- 3.6. Off Mode requirements for all displays

- 3.6.1. A product need not have an Off Mode to be eligible for qualification. For products that do offer an Off Mode, measured Off Mode power (P_{OFF}) shall be less than or equal to the Maximum Off Mode Power Requirement ($P_{\text{OFF_MAX}}$) in Table 8.

Table 8 Maximum Off Mode Power Requirement ($P_{\text{OFF_MAX}}$)

 $P_{\text{OFF_MAX}}$

(watts)

0,5

- 3.7. Luminance reporting requirements

- 3.7.1. Maximum Reported and Maximum Measured Luminance shall be reported for all products; As-Shipped Luminance shall be reported for all products except those with ABC enabled by default.

4. Test requirements

- 4.1. Test methods

Status: This is the original version (as it was originally adopted).

- 4.1.1. Test methods identified in Table 9 shall be used to determine qualification for Energy Star.

TABLE 9

Test Methods for Energy Star Qualification

Product Type	Test Method
All Product Types and Screen Sizes	Energy Star Test Method for Determining Display Energy
Enhanced Performance Displays	International Committee for Display Metrology (ICDM) Information Display Measurements Standard — Version 1.03
Displays Claiming Full Network Connectivity	CEA-2037-A, Determination of Television Set Power Consumption

- 4.2. Number of units required for testing
- 4.2.1. One unit of a Representative Model, as defined in Section 1, shall be selected for testing.
- 4.2.2. For qualification of a Product Family, the product configuration that represents the worst-case power demand for each product category within the Product Family shall be considered the Representative Model.
5. **User interface**
- 5.1. Manufacturers are encouraged to design products in accordance with the user interface standard, IEEE P1621: Standard for User Interface Elements in Power Control of Electronic Devices Employed in Office/Consumer Environments. For details, see <http://energy.lbl.gov/controls/>
6. **Effective date**
- 6.1. Effective Date: The Version 7.0 Energy Star Display specification shall take effect on the effective date of the Agreement. To qualify for Energy Star, a product model shall meet the Energy Star specification in effect on its date of manufacture. The date of manufacture is specific to each unit and is the date on which a unit is considered to be completely assembled.
- 6.2. Future Specification Revisions: The European Commission reserves the right to change this specification should technological and/or market changes affect its usefulness to consumers, industry, or the environment. In keeping with current policy, revisions to the specification are arrived at through stakeholder discussions. In the event of a specification revision, please note Energy Star qualification is not automatically granted for the life of a model.
7. **Considerations for future revisions**
- 7.1. On Mode DC Power Limit: EPA and the European Commission are interested in considering a separate On Mode Power Maximum requirement for Standard DC products that does not necessitate an AC-DC conversion calculation. EPA and the European Commission anticipate these products will become more popular on the

market with the latest USB standard and look forward to receiving additional direct DC-tested data for these products.

FINAL Rev. Sep-2015 TEST METHOD FOR DISPLAYS

1. Overview

The following test method shall be used for determining product compliance with requirements in the Energy Star Specification for Displays.

2. Applicability

The following test method is applicable to all products eligible for qualification under the Energy Star Product Specification for Displays.

3. Definitions

Unless otherwise specified, all terms used in this document are consistent with the definitions in the Energy Star Specification for Displays.

(A) Host Machine : The machine or device used as the source of video/audio signal for testing Displays. It may be a computer or any other device capable of providing a video signal.

4. Test set-up

(A) Test Set-up and Instrumentation: Test set-up and instrumentation for all portions of this method shall be in accordance with the requirements of International Electrotechnical Commission (IEC) 62301:2011, 'Household electrical appliances — Measurement of standby power,' Section 4, 'General Conditions for Measurements,' unless otherwise noted in this document. In the event of conflicting requirements, the Energy Star Test Method shall take precedence.

(B) AC Input Power: Products capable of being powered from AC mains shall be connected to a voltage source appropriate for the intended market, as specified in Table 10. If an external power supply is shipped with the product, it shall be used to connect the product to the specified voltage source.

TABLE 10

Input Power Requirements for Products

Market	Voltage	Voltage Tolerance	Maximum Total Harmonic Distortion	Frequency	Frequency Tolerance
North America, Taiwan	115 V AC	+/- 1,0 %	5,0 %	60 Hz	+/- 1,0 %
Europe, Australia,	230 V AC	+/- 1,0 %	5,0 %	50 Hz	+/- 1,0 %

Status: This is the original version (as it was originally adopted).

New Zealand					
Japan	100 V AC	+/- 1,0 %	5,0 %	50 Hz or 60 Hz	+/- 1,0 %

(C) DC Input Power:

- (1) Products may be tested with a DC source (e.g. via network or data connection) only if DC is the only available source of power for the product (i.e. no AC plug or External Power Supply (EPS) is shipped with the product).
- (2) DC-powered products shall be installed and powered as directed by the manufacturer, using a port with the full specifications recommended for the Display (e.g. Universal Serial Bus (USB) 3.1 if applicable, even if backwards-compatible with USB 2.0).
- (3) The power measurement shall be made between the DC source (e.g. Host Machine) and the cable shipped with the product, including the losses introduced by the shipped cable. If no cable is shipped with the product, any cable between 2 and 6 feet long may be used in its place. The resistance of the cable used to connect the Display to the point of measurement shall be measured and reported.

Note: The measured resistance of DC power cables includes the sum of resistances of both the DC supply voltage wire and the ground wire.

- (4) A spliced cable may be used between the shipped cable and DC source in order to connect the power meter. If this method is used, the following requirements must be met:
 - (a) The spliced cable shall be used in addition to the shipped cable described in Section 4(C)(3).
 - (b) The spliced cable shall be connected between the DC source and the shipped cable.
 - (c) The spliced cable shall be no longer than 1 foot.
 - (d) For measuring voltage, the total amount of wiring used between the voltage measurement and the shipped cable shall be less than 50 milliohms of resistance. This only applies to the wiring that is carrying load current.

Note: Voltage and current need not necessarily be measured at the same location, so long as the voltage is measured within 50 milliohms of the shipped cable.

- (e) The current measurement can be made either on the ground wire or the DC supply voltage wire.
- (f) Figure 1 depicts an example spliced cable set-up using a USB 2.0-powered Display connected to the Host Machine.

Figure 1

Example Spliced USB 2.0 Cable Arrangement

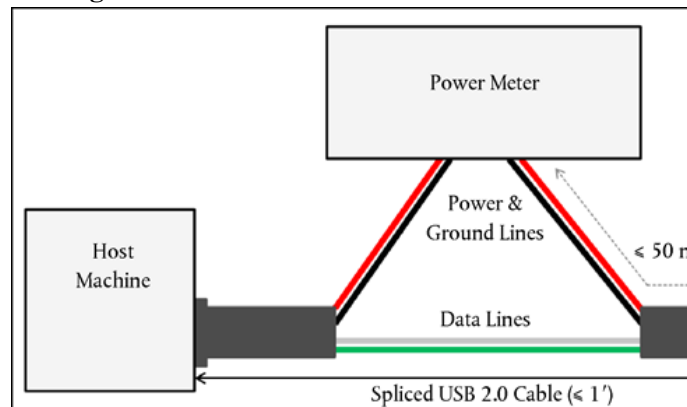

- (D) Ambient Temperature: Ambient temperature shall be $23\text{ }^{\circ}\text{C} \pm 5\text{ }^{\circ}\text{C}$.
- (E) Relative Humidity: Relative humidity shall be from 10 % to 80 %.
- (F) UUT Alignment:
- (1) All four corners of the face of the Unit Under Test (UUT) shall be equidistant from a vertical reference plane (e.g. wall).
 - (2) The bottom two corners of the face of the UUT shall be equidistant from a horizontal reference plane (e.g. floor).
- (G) Light Source for On Mode Testing:
- (1) Lamp Type:
 - (a) Standard spectrum halogen flood reflector lamp. The lamp shall not meet the definition of 'Modified spectrum' as defined in 10 CFR 430.2 — Definitions⁽¹⁾.
 - (b) Rated Brightness: $980 \pm 5\%$ lumens.
 - (2) Light Source Alignment for Testing Products With ABC Enabled By Default:
 - (a) There shall be no obstructions between the lamp and the UUT's Automatic Brightness Control (ABC) sensor (e.g. diffusing media, frosted lamp covers, etc.).
 - (b) The centre of the lamp shall be placed at a distance of 5 feet from the centre of the ABC sensor.
 - (c) The centre of the lamp shall be aligned at a horizontal angle of 0° with respect to the centre of the UUT's ABC sensor.
 - (d) The centre of the lamp shall be aligned at a height equal to the centre of the UUT's ABC sensor with respect to the floor (i.e. the light source shall be placed at a vertical angle of 0° with respect to the centre of the UUT's ABC sensor).

Status: This is the original version (as it was originally adopted).

- (e) No test room surface (i.e. floor, ceiling, and wall) shall be within 2 feet of the centre of the UUT's ABC Sensor.
- (f) Illuminance values shall be obtained by varying the input voltage of the lamp.
- (g) Figure 2 and Figure 3 and provide more information on UUT and light source alignment.

Figure 2

Test Set-up — Top View

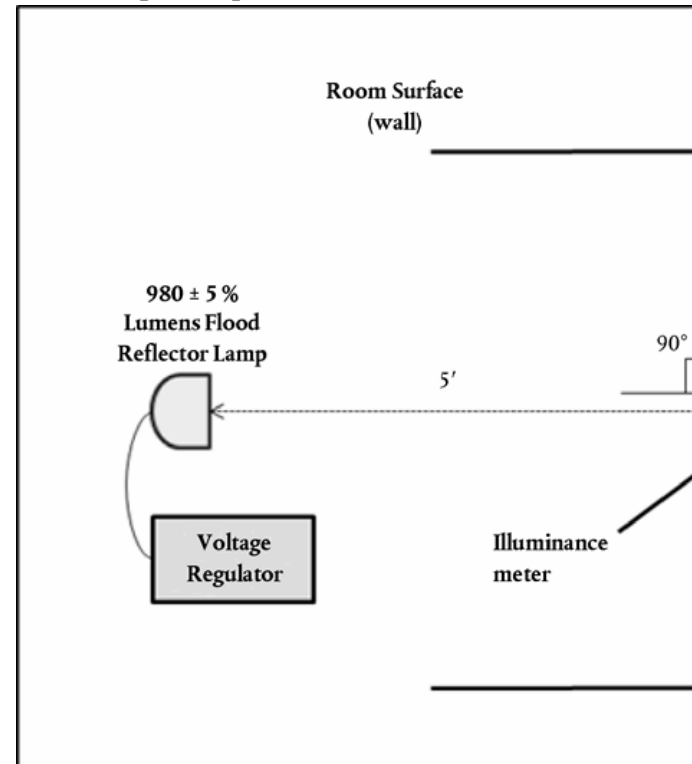

Notes:

- $D_1 = D_2$ with respect to vertical reference plane,
- D_1 and D_2 indicate that the corners of the face of the UUT shall be at least 2 feet from the vertical reference plane,
- D_3 and D_4 indicate that the centre of the light sensor shall be at least 2 feet from the room walls.

Figure 3

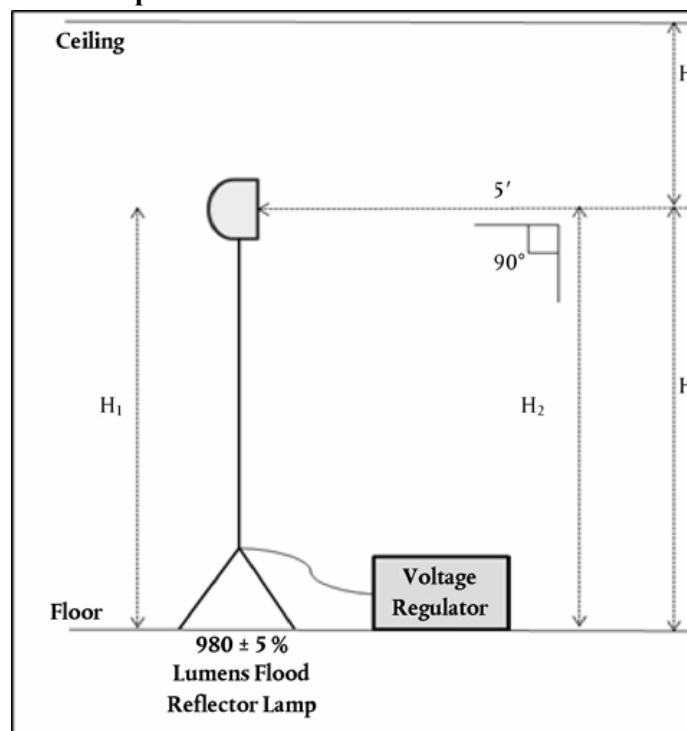
Test Set-up — Side View*Notes:*

- $D_1 = D_2$ with respect to vertical reference plane,
- D_1 and D_2 indicate that the corners of the face of the UUT shall be at least 2 feet from the vertical reference plane,
- illuminance meter shall be removed for power measurements, after target illuminance achieved,
- $H_1 = H_2$ with respect to horizontal reference plane (e.g. floor),
- H_3 and H_4 indicate that the centre of the light sensor must be at least 2 feet from the floor and 2 feet from the ceiling,
- illuminance meter removed for power measurements, after target illuminance achieved.

(H) Power Meter: Power meters shall possess the following attributes

(1) Crest Factor:

- (a) An available current crest factor of 3 or more at its rated range value; and
- (b) Lower bound on the current range of 10 mA or less.

(2) Minimum Frequency Response: 3,0 kHz

(3) Minimum Resolution:

- (a) 0,01 W for measurement values less than or equal to 10 W;

- (b) 0,1 W for measurement values from greater than 10 W to 100 W;
and
- (c) 1,0 W for measurement values greater than 100 W.

(I) Luminance and Illuminance Meters:

- (1) Luminance measurement shall be performed using either
 - (a) A contact meter; or
 - (b) A non-contact meter.
- (2) All luminance and illuminance meters shall be accurate to $\pm 2\%$ (± 2 digits) of the digitally displayed value.
- (3) Non-contact luminance meters shall have an acceptance angle of 3 degrees or less.

The overall accuracy of a meter is found by taking (\pm) the absolute sum of 2 % of the measurement and a 2-digit tolerance of the displayed value least significant digit. For example, if an illuminance meter displays '200,0' when measuring a screen brightness of 200 nits, 2 % of 200 nits is 4,0 nits. The least significant digit is 0,1 nits. 'Two digits' implies 0,2 nits. Thus, the displayed value would be $200 \pm 4,2$ nits (4 nits + 0,2 nits). The accuracy is specific to the illuminance meter and shall not be considered as tolerance during actual light measurements.

(J) Measurement Accuracy:

- (1) Power measurements with a value greater than or equal to 0,5 W shall be made with an uncertainty of less than or equal to 2 % at the 95 % confidence level.
- (2) Power measurements with a value less than 0,5 W shall be made with an uncertainty of less than or equal to 0,01 W at the 95 % confidence level.
- (3) All ambient light values (measured lux) shall be measured at the location of the ABC sensor on the UUT with light entering directly into the sensor and with the main menu from the test signal from IEC 62087:2011, 'Methods of measurement for the power consumption of audio, video and related equipment' displayed on the product. For products not compatible with the IEC test signal format, ambient light values shall be measured with the Video Electronics Standard Association (VESA) Flat Panel Display Measurements Standard version 2.0 (FPDM2) FK test signal being displayed on the product.
- (4) Ambient light values shall be measured within the following tolerances:
 - (a) At 12 lux, ambient lighting shall be within $\pm 1,0$ lux; and
 - (b) At 300 lux, ambient lighting shall be within $\pm 9,0$ lux.

5. **Test conduct**

5.1. Guidance for power measurements

- (A) Testing at Factory Default Settings: Power measurements shall be performed with the product in its as-shipped condition for the duration of Sleep Mode and On Mode

testing, with all user-configurable options set to factory defaults, except as otherwise specified by this test method.

- (1) Picture level adjustments shall be performed as per the instructions in this test method.
 - (2) Products that include a 'forced menu' that requires picture setting selection upon initial start-up shall be tested in the 'standard' or 'home' picture setting. In the case that no standard setting or equivalent exists, the default setting recommended by the manufacturer shall be used for testing and recorded in the test report. Products that do not include a forced menu shall be tested in the default picture setting.
- (B) Point of Deployment (POD) Modules: Optional POD modules shall not be installed.
- (C) Plug-in Modules: Optional Plug-in Modules shall be removed from the Display if the Display can be tested according to the test method without the module installed.
- (D) Sleep Mode with Multiple Functionalities: If the product offers multiple options for device behaviour in Sleep Mode (e.g. quick start) or multiple methods by which Sleep Mode may be entered, the power during all Sleep Modes shall be measured and recorded. All Sleep Mode testing shall be carried out as per Section 6.5.

5.2. Conditions for power measurements

- (A) Power measurements:
- (1) Power measurements shall be taken from a point between the power source and the UUT. No Uninterruptible Power Supply (UPS) units may be connected between the power meter and the UUT. The power meter shall remain in place until all On Mode, Sleep Mode and Off Mode power data are fully recorded.
 - (2) Power measurements shall be recorded in watts as directly measured (unrounded) values at a rate of greater than or equal to 1 reading per second.
 - (3) Power measurements shall be recorded after voltage measurements are stable to within 1 %.
- (B) Dark Room Conditions:
- (1) Unless otherwise specified, the illuminance measured at the UUT screen with the UUT in Off Mode shall be less than or equal to 1,0 lux. If the UUT does not have an Off Mode, the illuminance shall be measured at the UUT screen with the UUT's power cord disconnected.
- (C) UUT Configuration and Control:
- (1) Peripherals and Network Connections:
 - (a) External peripheral devices (e.g. mouse, keyboard, external hard disk drive (HDD), etc.) shall not be connected to USB ports or other data ports on the UUT.
 - (b) Bridging: If the UUT supports bridging as per the definition in Section 1 of the Energy Star Specification for Displays Version 7.0, a bridge connection shall be made between the UUT and the Host Machine. The connection shall be made in the following order of

Status: This is the original version (as it was originally adopted).

preference. Only one connection shall be made and the connection shall be maintained for the duration of the test.

- (i) Thunderbolt;
- (ii) USB;
- (iii) Firewire (IEEE 1394);
- (iv) Other.

Note: Examples of bridging for Displays may include:

- (1) A case where the Display converts data between two different port types (e.g. Thunderbolt and Ethernet). This can allow a device to use Thunderbolt as an Ethernet connection or vice versa.
 - (2) Allowing a USB keyboard/mouse to be connected to another system (e.g. Host Machine) through the Display by a USB hub controller.
- (c) Networking: If the UUT has networking capability (i.e. it has the ability to obtain an IP address when configured and connected to a network) the networking capability shall be activated, and the UUT shall be connected to a live physical network (e.g. WiFi, Ethernet, etc.). The physical network shall support the highest and lowest data speeds of the UUT's network function. An active connection is defined as a live physical connection over the physical layer of the networking protocol. In the case of Ethernet, the connection shall be via a standard Cat 5e or better Ethernet cable to an Ethernet switch or router. In the case of WiFi the device shall be connected and tested in proximity to a wireless access point (AP). The tester shall configure the address layer of the protocol, taking note of the following:
- (i) Internet Protocol (IP) v4 and IPv6 have neighbour discovery and will generally configure a limited, non-routable connection automatically.
 - (ii) IP can be configured manually or by using Dynamic Host Configuration Protocol (DHCP) with an address in the 192.168.1.x Network Address Translation (NAT) address space if the UUT does not behave normally when autoIP is used. The network shall be configured to support the NAT address space and/or autoIP.
 - (iii) The UUT shall maintain this live connection to the network for the duration of testing unless otherwise specified in this Test Method, disregarding any brief lapses (e.g. when transitioning between link speeds). If the UUT is equipped with multiple network capabilities, only one connection shall be made in the following order of preference:
 - (a) WiFi (Institution of Electrical and Electronics Engineers — IEEE 802.11- 2007⁽²⁾);

- (b) Ethernet (IEEE 802.3). If the UUT supports Energy Efficient Ethernet (IEEE 802.3az-2010⁽⁹⁾), then it shall be connected to a device that also supports IEEE 802.3az;
 - (c) Thunderbolt;
 - (d) USB;
 - (e) Firewire (IEEE 1394);
 - (f) Other.
 - (d) Touchscreen Functionality: If the UUT features a touchscreen that requires a separate data connection, this function shall be set up as directed by the manufacturer's instructions, including connections to the Host Machine and installation of software drivers.
 - (e) In the case of a UUT that has a single connection capable of performing multiple functions (e.g. bridging, networking, and/or touchscreen functionality), a single connector can be used to meet these functionalities provided it is the highest preferred connection the UUT supports for each functionality.
 - (f) In the case of a UUT that has no data/network capabilities, the UUT shall be tested as shipped.
 - (g) Built-in speakers and other product features and functions not specifically addressed by the Energy Star Specification or test method must be configured in the as-shipped power configuration.
 - (h) Availability of other capabilities such as occupancy sensors, flash memory-card/smart-card readers, camera interfaces, PictBridge shall be recorded.
- (2) Signal Interface:
- (a) If the UUT has multiple signal interfaces, the UUT shall be tested with the first available interface from the list below:
 - (i) Thunderbolt;
 - (ii) DisplayPort;
 - (iii) HDMI;
 - (iv) DVI;
 - (v) VGA;
 - (vi) Other Digital Interface;
 - (vii) Other Analogue Interface.
- (3) Occupancy Sensor: If the UUT has an occupancy sensor, the UUT shall be tested with the occupancy sensor settings in the as-shipped condition. For UUT's with an occupancy sensor enabled as-shipped:

Status: This is the original version (as it was originally adopted).

- (a) A person shall be within close proximity of the occupancy sensor for the entire warm up, stabilisation, luminance testing and On Mode to prevent the UUT from entering a lower power state (e.g. Sleep Mode or Off Mode). The UUT shall remain in On Mode for the duration of the warm up period, stabilisation period, luminance test and On Mode test.
 - (b) No person shall be within close proximity of the occupancy sensor for the duration of the Sleep Mode and Off Mode tests to prevent the UUT from entering a higher power state (e.g. On Mode). The UUT shall remain in Sleep Mode or Off Mode for the duration of the Sleep Mode or Off Mode tests, respectively.
 - (4) Orientation: If the UUT can be rotated into vertical and horizontal orientations, it shall be tested in the horizontal orientation, with the longest dimension being parallel to the table surface.
- (D) Resolution and Refresh Rate:
 - (1) Fixed-pixel Displays:
 - (a) Pixel format shall be set to the native level as specified in the product manual.
 - (b) For non-Cathode Ray Tube (CRT) Displays, refresh rate shall be set to 60 Hz, unless a different default refresh rate is specified in the product manual, in which case the specified default refresh rate shall be used.
 - (c) For CRT Displays, pixel format shall be set to the highest resolution that is designed to be driven at a 75 Hz refresh rate, as specified in the product manual. Typical industry standards for pixel format timing shall be used for testing. Refresh rate shall be set to 75 Hz.
- (E) Accuracy of Input Signal Levels: When using analogue interfaces, video inputs shall be within $\pm 2\%$ of referenced white and black levels. When using digital interfaces, the source video signal shall not be adjusted for colour, or modified by the tester for any purpose other than to compress/inflate and encode/decode for transmission, as required.
- (F) True Power Factor: Programme participants shall report the true power factor (PF) of the UUT during On Mode measurement. The power factor values shall be recorded at the same rate at which the power value (P_{ON}) are recorded. The reported power factor shall be averaged over the entire duration of the On Mode testing.
- (G) Test Materials:
 - (1) 'IEC 62087:2011 Dynamic Broadcast-Content Signal' shall be used for testing, as specified in IEC 62087:2011, Section 11.6, 'On (average) mode testing using dynamic broadcast-content video signal'.
 - (2) 'VESA FPDm2' shall be used only for products that cannot display the IEC 62087:2011 Dynamic Broadcast-Content Signal.
- (H) Video Input Signal:

- (1) The Host Machine shall generate the video input signal in the native resolution of the Display such that the active area of the video fills the entire screen. This may require the playback software to adjust the aspect ratio of the video.
- (2) The frame rate of the video input signal should match the frame rate most commonly used in the region in which the product is sold (e.g. for the US and Japan, a 60 Hz frame rate is used; for Europe and Australia, a 50 Hz frame rate is used).
- (3) The audio settings on the Host Machine shall be disabled so that no sound is produced alongside the video input signal.

6. Test procedures for all products

6.1. Pre-test UUT initialisation

- (A) Prior to the start of testing, the UUT shall be initialised as follows:
 - (1) Set up the UUT as per the instructions in the supplied product manual.
 - (2) Connect an acceptable watt meter to the power source and connect the UUT to the power outlet on the watt meter.
 - (3) With the UUT off, set the ambient light level such that the measured screen illuminance is less than 1,0 lux (see Section 5.2(B)).
 - (4) Power on the UUT and perform initial system configuration, as applicable.
 - (5) Ensure UUT settings are in their as-shipped configuration, unless otherwise specified in this test method.
 - (6) Warm up the UUT for 20 minutes, or the time it takes the UUT to complete initialisation and become ready for use, whichever is longer. The IEC 62087:2011 test signal format, as specified in Section 5.2(G)(1), shall be displayed for the entire warm-up period. Displays that cannot display the IEC 62087:2011 test signal format shall have the VESA FPD M2 L80 test signal, as specified in Section 5.2(G)(2), displayed on the screen.
 - (7) Report the AC input voltage and frequency or DC input voltage.
 - (8) Report the test room ambient temperature and relative humidity.

6.2. Luminance testing

- (A) Luminance testing shall be performed immediately following the warm up period and in dark room conditions. Product screen illuminance, as measured with the UUT in Off Mode, shall be less than or equal to 1,0 lux.
- (B) Luminance shall be measured perpendicular to the centre of the product screen using a luminance meter in accordance with the meter's user manual.
- (C) The position of the luminance meter relative to the product screen shall remain fixed throughout the duration of testing.
- (D) For products with ABC, luminance measurements shall be performed with ABC disabled. If ABC cannot be disabled, luminance measurements shall be measured

perpendicular to the centre of the product screen with light entering directly into the UUT's ambient light sensor at greater than or equal to 300 lux.

- (E) Luminance measurements shall be performed as follows:
- (1) Verify that the UUT is in the default as-shipped luminance value or 'Home' picture setting.
 - (2) Display the test video signal for the specific product class, as described below:
 - (a) All products, except as specified in (b): Three-bar video signal specified in IEC 62087:2011, Section 11.5.5 (three bars of white (100 %) over a black (0 %) background).
 - (b) Products that cannot display signals from IEC 62087:2011: VESA FPDM2 L80 test signal for the maximum resolution supported by the product.
 - (3) Display the test video signal for no less than 10 minutes to allow the UUT luminance to stabilise. This 10-minute stabilisation period may be reduced if luminance measurements are stable to within 2 % over a period of not less than 60 seconds.
 - (4) Measure and record the luminance in default as-shipped setting $L_{As-shipped}$.
 - (5) Set the brightness and contrast levels of the UUT to their maximum values.
 - (6) Measure and record the luminance as $L_{Max_Measured}$.
 - (7) Record the manufacturer-reported maximum luminance $L_{Max_Reported}$.
- (F) The contrast setting shall be left at the maximum level for the subsequent On Mode tests unless otherwise specified.
- 6.3. On Mode testing for products without ABC enabled by default
- (A) After the Luminance Testing and prior to On Mode power measurement, the luminance of the UUT shall be set according to the following:
- (1) For Signage Displays, the product shall be tested with luminance set at a value greater than or equal to 65 % of the manufacturer-reported maximum luminance ($L_{Max_Reported}$). Luminance values shall be measured as per Section 6.2. This luminance value L_{On} shall be recorded.
 - (2) For all other products, adjust appropriate luminance controls until the luminance of the screen is 200 candelas per square metre (cd/m^2). If the UUT cannot achieve this luminance, set the product luminance to the nearest achievable value. Luminance values shall be measured as per Section 6.2. This luminance value L_{On} shall be reported. Appropriate luminance controls refer to any controls that adjust the brightness of the Display, but do not include contrast settings.
- (B) For a UUT capable of displaying the IEC signals, On Mode power (P_{ON}) shall be measured according to IEC 62087:2011 Section 11.6.1 'Measurements using dynamic broadcast-content video signal.' For a UUT not capable of displaying the IEC signals, On Mode power (P_{ON}) shall be measured as follows:

- (1) Ensure that the UUT has been initialised as per Section 6.1.
- (2) Display the VESA FPDM2, A112-2F, SET01K test pattern (8 shades of grey from full black (0 volts) to full white (0,7 volts)).
- (3) Verify that input signal levels conform to VESA Video Signal Standard (VSIS), Version 1.0, Rev. 2.0, December 2002.
- (4) With the brightness and contrast controls at maximum, verify that the white and near-white grey levels can be distinguished. If necessary, adjust contrast controls until the white and near-white grey levels can be distinguished.
- (5) Display the VESA FPDM2, A112-2H, L80 test pattern (full white (0,7 volts) box that occupies 80 % of the image).
- (6) Ensure that the luminance measurement area falls entirely within the white portion of the test pattern.
- (7) Adjust appropriate luminance controls until the luminance of the white area of the screen is set as described in Section 6.3(A).
- (8) Record the screen luminance (L_{On}).
- (9) Record On Mode power (P_{ON}) and total pixel format (horizontal \times vertical). The On Mode power shall be measured over a 10-minute period similar to the IEC 62087:2011 dynamic broadcast-content test.

6.4. On Mode testing for products with ABC enabled by default

The average On Mode power consumption of the product shall be determined with the dynamic broadcast-content as defined in IEC 62087:2011. If the product cannot display the IEC signal, then the VESA FPDM2 L80 test pattern, as described in Section 6.3(B)(5), shall be used for all of the following steps.

- (A) Stabilise the UUT for 30 minutes. This shall be done with three repetitions of the 10-minute IEC dynamic broadcast-content video signal.
- (B) Set the light output of the lamp used for testing to 12 lux as measured at the face of the ambient light sensor.
- (C) Display the 10 minute dynamic broadcast-content video signal. Measure and record the power consumption, P_{12} , during the 10 minute dynamic broadcast-content video signal.
- (D) Repeat steps 6.4(B) and 6.4(C) for an ambient light level of 300 lux, to measure P_{300} .
- (E) Disable ABC and measure On Mode power (P_{ON}) as per Section 6.3. If ABC cannot be disabled, power measurements shall be conducted as follows:
 - (1) If the brightness can be set to a fixed value as specified in Section 6.3, then On Mode power for these products shall be measured as per Section 6.3 with light entering directly into the UUT's ambient light sensor at greater than or equal to 300 lux.
 - (2) If the brightness cannot be set to a fixed value, then On Mode power for these products shall be measured as per Section 6.3 with light entering directly

into the UUT's ambient light sensor at greater than or equal to 300 lux and without modifying the screen brightness.

6.5. Sleep Mode testing

- (A) Sleep Mode power (P_{SLEEP}) shall be measured according to IEC 62301:2011, with the additional guidance in Section 5.
- (B) The Sleep Mode test shall be conducted with the UUT connected to the Host Machine in the same manner as in the On Mode test. If possible, Sleep Mode shall be enacted by putting the Host Machine to sleep. For a computer Host Machine, Sleep Mode is defined in the Version 6.1 Energy Star Computers specification.
- (C) If the product has a variety of Sleep Modes that may be manually selected, or if the product can enter Sleep Mode via different methods (e.g. remote control or putting the Host Machine to sleep), measurements shall be performed and recorded in all Sleep Modes.

If the product automatically transitions through its various Sleep Modes, the measurement time shall be long enough to obtain an average of all Sleep Modes. The measurement shall still meet requirements (e.g. stability, measurement period, etc.) outlined in Section 5.3 of IEC 62301:2011.

6.6. Off Mode testing

- (A) For products having Off Mode capability, at the conclusion of the Sleep Mode test, initiate Off Mode via the most easily accessible power switch.
- (B) Measure Off Mode power (P_{OFF}) according to Section 5.3.1 of the IEC 62301:2011. Document the method of adjustment and sequence of events required to reach Off Mode.
- (C) Any input synchronising signal check cycle may be ignored when measuring Off Mode power.

6.7. Additional testing

- (A) For products with data/networking capabilities or a bridge connection, in addition to tests performed with data/networking capabilities activated and a bridge connection established (see Section 5.2(C)(1)), Sleep Mode Testing shall be performed with data/networking features deactivated and without any bridge connection established, as per Section 5.2(C)(1)(b) and (c).
- (B) The presence of Full Network Connectivity shall be determined by testing the Display for network activity in Sleep Mode according to Section 6.7.5.2 of CEA-2037-A, Determination of Television Set Power Consumption, with the following guidance:
 - (1) The Display shall be connected to a network as per Section 5.2(C)(1)(c) prior to the test.
 - (2) The Display shall be placed into Sleep Mode in place of standby-active, low.

- (1) <http://www.gpo.gov/fdsys/pkg/CFR-2011-title10-vol3/pdf/CFR-2011-title10-vol3-sec430-2.pdf>
- (2) IEEE 802 — Telecommunications and information exchange between systems—Local and metropolitan area networks — Part 11: Wireless LAN Medium Access Control (MAC) and Physical Layer (PHY) Specifications
- (3) Part 3: Carrier Sense Multiple Access with Collision Detection (CSMA/CD) Access Method and Physical Layer Specifications — Amendment 5: Media Access Control Parameters, Physical Layers, and Management Parameters for Energy-Efficient Ethernet