

This document is meant purely as a documentation tool and the institutions do not assume any liability for its contents

► **B**

**COMMISSION DECISION**

**of 1 March 2013**

**establishing the guidelines for Member States on calculating renewable energy from heat pumps from different heat pump technologies pursuant to Article 5 of Directive 2009/28/EC of the European Parliament and of the Council**

*(notified under document C(2013) 1082)*

**(Text with EEA relevance)**

(2013/114/EU)

(OJ L 62, 6.3.2013, p. 27)

Corrected by:

► **C1** Corrigendum, OJ L 8, 11.1.2014, p. 32 (2013/114/EU)

**COMMISSION DECISION****of 1 March 2013****establishing the guidelines for Member States on calculating renewable energy from heat pumps from different heat pump technologies pursuant to Article 5 of Directive 2009/28/EC of the European Parliament and of the Council***(notified under document C(2013) 1082)***(Text with EEA relevance)**

(2013/114/EU)

THE EUROPEAN COMMISSION,

Having regard to the Treaty on the Functioning of the European Union,

Having regard to Directive 2009/28/EC of the European Parliament and of the Council of 23 April 2009 on the promotion of the use of energy from renewable sources and amending and subsequently repealing Directives 2001/77/EC and 2003/30/EC <sup>(1)</sup>, and in particular Article 5(4) in conjunction with Annex VII thereto,

Whereas:

- (1) Directive 2009/28/EC sets out an EU target of 20 % renewable energy in gross final consumption of energy to be achieved by 2020 and contains national targets for renewable energy for each Member State, and an indicative minimum trajectory.
- (2) An appropriate energy statistics methodology is necessary to measure the consumption of renewable energy.
- (3) Annex VII to Directive 2009/28/EC sets out the rules for accounting of energy from heat pumps and requires the Commission to establish guidelines for Member States to estimate the necessary parameters, taking into consideration differences in climatic conditions, especially very cold climates.
- (4) The method to account renewable energy from heat pumps should build on best available science, be as accurate as possible, while not being overly complicated and costly to implement.
- (5) Only ambient air, i.e. outdoor air, can be the source of energy for an air-sourced heat pump. However, if the energy source is a mixture of waste energy and ambient energy (e.g. exhaust air from air-circulation units), the method for calculating the renewable energy supplied should reflect this.

<sup>(1)</sup> OJ L 140, 5.6.2009, p. 16.

**▼B**

- (6) Reversible heat pumps in warmer climates are often installed with the purpose of cooling the indoor environment, although they can also be used to provide heating during the winter. Such heat pumps might also be installed in parallel to an existing heating system. In such situations, the installed capacity reflects the cooling demand rather than the supplied heating. As the installed capacity is used as an indicator of heating demand in these guidelines, it implies that the statistics of installed capacity will over-estimate the amount of heating supplied. This needs appropriate adjustment.
- (7) These guidelines allow Member States to account for and calculate the renewable energy supplied from heat pump technologies. In particular they set out how Member States shall estimate the two parameters  $Q_{\text{usable}}$  and the 'seasonal performance factor' (SPF), taking into consideration differences in climatic conditions, especially very cold climates.
- (8) It is appropriate to allow Member States to undertake their own calculations and surveys in order to improve the accuracy of national statistics beyond what is feasible with the methodology set out in this Decision,

HAS ADOPTED THIS DECISION:

*Article 1*

The guidelines for estimating the renewable energy production from different heat pump technologies as required by Annex VII to Directive 2009/28/EC are set out in the Annex to this Decision.

*Article 2*

The guidelines may be revised and complemented by the Commission no later than 31 December 2016, if statistical, technical or scientific progress makes it necessary.

*Article 3*

This Decision is addressed to the Member States.



## ANNEX

**Guidelines for Member States on calculating renewable energy from heat pumps from different heat pump technologies pursuant to Article 5 of Directive 2009/28/EC**

## 1. INTRODUCTION

Annex VII to the Renewable Energy Directive 2009/28/EC (the Directive) establishes the basic method for calculating renewable energy supplied by heat pumps. Annex VII sets out three parameters that are needed for the calculation of the renewable energy from heat pumps to be counted for the renewable energy targets;

- (a) the power system efficiency ( $\eta$  or eta);
- (b) the estimated amount of useful energy supplied from the heat pumps ( $Q_{\text{usable}}$ );
- (c) the ‘seasonal performance factor’ (SPF).

The methodology for determining the power system efficiency ( $\eta$ ) was agreed in the Renewable Energy Statistics Working Party of 23 October 2009<sup>(1)</sup>. The data required for the calculation of the power system efficiency is covered by Regulation (EC) No 1099/2008 of the European Parliament and of the Council of 22 October 2008<sup>(2)</sup> on energy statistics. The power system efficiency ( $\eta$ ) is set at 0,455 (or 45,5 %), based on the most recent data for 2010<sup>(3)</sup>, which is the value to be used towards 2020.

These guidelines therefore set out how Member States should estimate the two remaining parameters of  $Q_{\text{usable}}$  and the ‘seasonal performance factor’ (SPF), taking into consideration differences in climatic conditions, especially very cold climates. With these guidelines Member States are enabled to calculate the amount of renewable energy supplied by heat pump technologies.

## 2. DEFINITIONS

For the purpose of this Decision, the following definitions apply:

‘ $Q_{\text{usable}}$ ’ means the estimated total usable heat delivered by heat pumps, calculated as the product of the rated capacity for heating ( $P_{\text{rated}}$ ) and the annual equivalent heat pump hours ( $H_{\text{HP}}$ ), expressed in GWh;

‘annual equivalent heat pump hours’ ( $H_{\text{HP}}$ ) means the assumed annual number of hours a heat pump has to provide heat at rated capacity to deliver the total usable heat delivered by heat pumps, expressed in h;

<sup>(1)</sup> See point 4.5 of minutes of 23 October 2009, available here: <https://circabc.europa.eu/w/browse/be80a323-0f89-4ab7-b8f7-888e3ff351ed>

<sup>(2)</sup> OJ L 304, 14.11.2008, p. 1.

<sup>(3)</sup> The value for  $\eta$  in 2010 is 45,5 % (developing from 44,0 % in 2007, 44,7 % 2008 and 45,1 % in 2009), leading to a minimum SPF of 2,5 in 2010. This is a conservative estimate, as the power system efficiency is expected to increase towards 2020. However, as the basis of estimating the power system efficiency ( $\eta$ ) changes due to updates in the underlying statistics, it is more predictable to set the  $\eta$  at a fixed level in order to avoid confusion regarding the minimum SPF requirements (create legal certainty) and also to facilitate methodology development by Member States (see Section 3.10). If necessary,  $\eta$  can be revised as per Article 2 (revision of guidelines if necessary by 31 December 2016).

**▼ B**

‘rated capacity’ ( $P_{\text{rated}}$ ) means the cooling or heating capacity of the vapour compression cycle or sorption cycle of the unit at standard rating conditions;

‘SPF’ shall mean the estimated average seasonal performance factor, which refers to the ‘net seasonal coefficient of performance in active mode’ ( $\text{SCOP}_{\text{net}}$ ) for electrically driven heat pumps or ‘net seasonal primary energy ratio in active mode’ ( $\text{SPER}_{\text{net}}$ ) for thermally driven heat pumps.

### 3. ESTIMATING SPF AND $Q_{\text{USABLE}}$

#### 3.1. Methodology Principles

The methodology follows three main principles:

- (a) the methodology has to be technically sound;
- (b) the approach must be pragmatic, balancing accuracy and cost-effectiveness;
- (c) the default factors for establishing the contribution of renewable energy from heat pumps are set at a conservative level to lower the risk of overestimating the contribution of renewable energy from heat pumps.

Member States are encouraged to improve the conservative default values by adapting them to national/regional circumstances, including the development of more accurate methodologies. Such improvements should be reported to the Commission and made publicly available.

#### 3.2. Outline of methodology

In accordance with Annex VII to the Directive, the amount of renewable energy supplied by heat pump technologies ( $E_{\text{RES}}$ ) shall be calculated with the following formula:

$$E_{\text{RES}} = Q_{\text{usable}} * (1 - 1/\text{SPF})$$

$$Q_{\text{usable}} = H_{\text{HP}} * P_{\text{rated}}$$

Where:

- $Q_{\text{usable}}$  = the estimated total usable heat delivered by heat pumps [GWh],
- $H_{\text{HP}}$  = equivalent full load hours of operation [h],
- $P_{\text{rated}}$  = capacity of heat pumps installed, taking into account the lifetime of different types of heat pumps [GW],
- SPF = the estimated average seasonal performance factor ( $\text{SCOP}_{\text{net}}$  or  $\text{SPER}_{\text{net}}$ ).

Default values for  $H_{\text{HP}}$  and conservative default SPF values are set out in Tables 1 and 2 in Section 3.6.

#### 3.3. Minimum performance of heat pumps to be considered as renewable energy under the Directive

In accordance with Annex VII to the Directive, Member States shall ensure that only heat-pumps with a SPF above  $1,15 * 1/\eta$  are taken into account.

With power system efficiency ( $\eta$ ) set at 45,5 % (see Section 1 and footnote 3) it implies that the minimum SPF of electrically driven heat pumps ( $\text{SCOP}_{\text{net}}$ ) to be considered as renewable energy under the Directive is 2,5.

▼ **B**

For heat pumps that are driven by thermal energy (either directly, or through the combustion of fuels), the power system efficiency ( $\eta$ ) is equal to 1. For such heat pumps the minimum SPF ( $SPER_{net}$ ) is 1,15 for the purposes of being considered as renewable energy under the Directive.

Member States should consider, in particular for air sourced heat pumps, how large a fraction of their already installed capacity of heat pumps have a SPF above the minimum performance. In that assessment the Member States may rely on both test data and measurements, although lack of data may in many cases reduce the assessment to expert judgment by each Member State. Such expert judgments should be conservative, meaning that the estimates rather underestimate than overestimate the contribution of heat pumps <sup>(1)</sup>. In the case of air-sourced water heaters it is normally only in exceptional cases that such heat pumps have an SPF above the minimum threshold.

### 3.4. System boundaries for measuring energy from heat pumps

The system boundaries for measurement include the refrigerant cycle, the refrigerant pump and, for ad/absorption, in addition the sorption cycle and solvent pump. The determination of the SPF should be according to the seasonal coefficient of performance ( $SCOP_{net}$ ) according to EN 14825:2012 or seasonal primary energy ratio ( $SPER_{net}$ ) according to EN 12309. That implies that electric energy or fuel consumption for operation of the heat pump and circulation of the refrigerant should be taken into account. The corresponding system boundary is shown in Figure 1 below as  $SPFH_2$ , highlighted in red.

Figure 1

System boundaries for measurement of SPF and  $Q_{usable}$

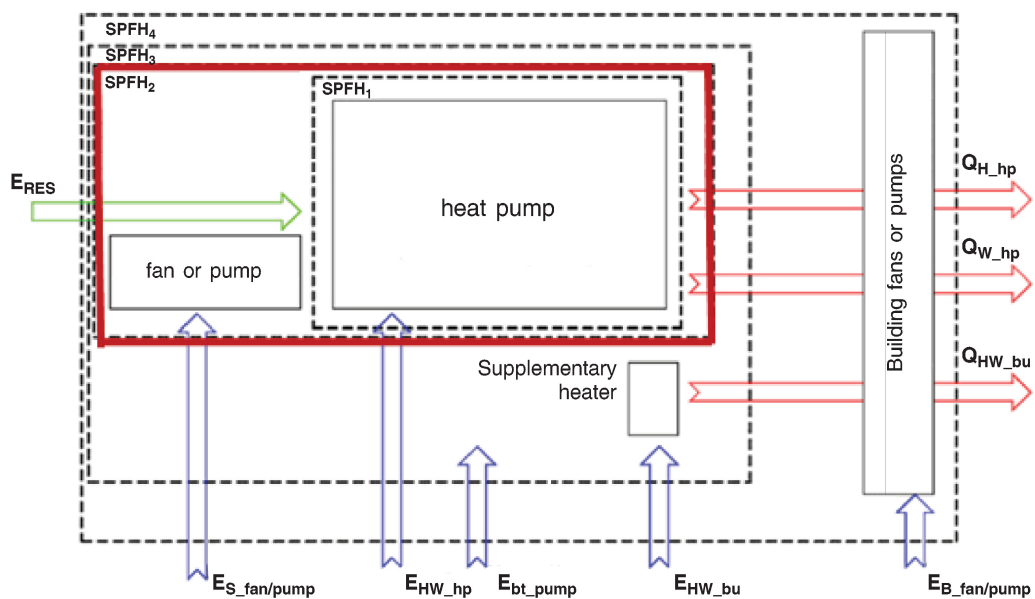

<sup>(1)</sup> Particular attention is required regarding reversible air sourced heat pumps, as a number of potential sources of overestimation exist, notably: (a) not all reversible heat pumps are used for heating, or only to a limited extent, and (b) older (and new less efficient) units may have an efficiency (SPF) below the required minimum threshold of 2,5.

**▼ B**

*Source:* SEPEMO build.

The following abbreviations are used in Figure 1:

$E_{S\_fan/pump}$  Energy used to run fan and/or pump that circulates the refrigerant

$E_{HW\_hp}$  Energy used to run the heat pump itself

$E_{bt\_pump}$  Energy used to run pump that circulates the medium that absorbs the ambient energy (not relevant for all heat pumps)

$E_{HW\_bu}$  Energy used to run supplementary heater (not relevant for all heat pumps)

$E_{B\_fan/pump}$  Energy used to run fan and/or pump that circulates the medium that supplies the final usable heat

$Q_{H\_hp}$  Heat supplied from the heat source via the heat pump

$Q_{W\_hp}$  Heat supplied from the mechanical energy used to drive the heat pump

$Q_{HW\_hp}$  Heat supplied from the supplementary heater (not relevant for all heat pumps)

$E_{RES}$  Renewable aerothermal, geothermal or hydrothermal energy (the heat source) captured by the heat pump

$E_{RES}$   $E_{RES} = Q_{usable} - E_{S\_fan/pump} - E_{HW\_hp}$   
 $= Q_{usable} * (1 - 1/SPF)$

$Q_{usable}$   $Q_{usable} = Q_{H\_hp} + Q_{W\_hp}$

It follows from the system boundaries set out above, that the calculation of renewable energy supplied by the heat pump depends on the heat pump alone and not the heating system the heat pump is a part of. Inefficient use of heat pump energy is therefore a matter of energy efficiency, and should therefore not influence the calculations of renewable energy supplied by heat pumps.

### 3.5. Climate conditions

The definition of average, colder and warmer climate conditions follows the method as proposed in the draft for Commission Delegated Regulation on energy labelling of boilers<sup>(1)</sup>, where ‘average climate conditions’, ‘colder climate conditions’ and ‘warmer climate conditions’ mean the temperature conditions characteristic for the cities of Strasbourg, Helsinki and Athens, respectively. Suggested climate condition areas are set out in Figure 2 below.

<sup>(1)</sup> This draft has not been adopted yet by the Commission (January 2013). The draft can be found in the WTO’s database: [http://members.wto.org/cnattachments/2012/tbt/EEC/12\\_2119\\_00\\_e.pdf](http://members.wto.org/cnattachments/2012/tbt/EEC/12_2119_00_e.pdf)



**Figure 2**  
Climate condition areas

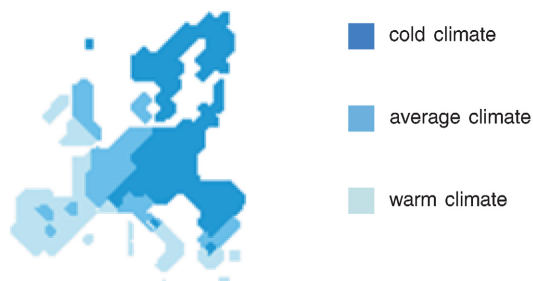

In cases where several climate conditions are existing within the same Member State, the Member States should estimate the installed capacity of heat pumps in the respective climate condition area.

### 3.6. Default values for SPF and $Q_{usable}$ for heat pumps

The default values for  $H_{HP}$  and SPF ( $SCOP_{net}$ ) for electrically driven heat pumps are as set out in the table below:

Table 1

Default values for  $H_{HP}$  and SPF ( $SCOP_{net}$ ) for electrically driven heat pumps

Heat Pump Energy source:	Energy source and distribution medium	Climate conditions					
		Warmer climate		Average climate		Colder climate	
		$H_{HP}$	SPF ( $SCOP_{net}$ )	$H_{HP}$	SPF ( $SCOP_{net}$ )	$H_{HP}$	SPF ( $SCOP_{net}$ )
Aerothermal energy	Air-Air	1 200	2,7	1 770	2,6	1 970	2,5
	Air-Water	1 170	2,7	1 640	2,6	1 710	2,5
	Air-Air (reversible)	► <u>C1</u> 120 ◀	2,7	710	2,6	1 970	2,5
	Air-Water (reversible)	► <u>C1</u> 120 ◀	2,7	660	2,6	1 710	2,5
	Exhaust Air-Air	760	2,7	660	2,6	600	2,5
	Exhaust Air-Water	760	2,7	660	2,6	600	2,5
Geothermal energy	Ground-Air	1 340	3,2	2 070	3,2	2 470	3,2
	Ground-Water	1 340	3,5	2 070	3,5	2 470	3,5
Hydrothermal heat	Water-Air	1 340	3,2	2 070	3,2	2 470	3,2
	Water-Water	1 340	3,5	2 070	3,5	2 470	3,5



**▼B**

The default values for  $H_{HP}$  and SPF ( $SPER_{net}$ ) for heat pumps driven by thermal energy are as set out in the table below:

Table 2

**Default values for  $H_{HP}$  and SPF ( $SPER_{net}$ ) for heat pumps driven by thermal energy**

Heat Pump Energy source:	Energy source and distribution medium	Climate conditions					
		Warmer climate		Average climate		Colder climate	
		$H_{HP}$	SPF ( $SPER_{net}$ )	$H_{HP}$	SPF ( $SPER_{net}$ )	$H_{HP}$	SPF ( $SPER_{net}$ )
Aerothermal energy	Air-Air	1 200	1,2	1 770	1,2	1 970	1,15
	Air-Water	1 170	1,2	1 640	1,2	1 710	1,15
	Air-Air (reversible)	► <u>C1</u> 120 ◀	1,2	710	1,2	1 970	1,15
	Air-Water (reversible)	► <u>C1</u> 120 ◀	1,2	660	1,2	1 710	1,15
	Exhaust Air-Air	760	1,2	660	1,2	600	1,15
	Exhaust Air-Water	760	1,2	660	1,2	600	1,15
Geothermal energy	Ground-Air	1 340	1,4	2 070	1,4	2 470	1,4
	Ground-Water	1 340	1,6	2 070	1,6	2 470	1,6
Hydrothermal heat	Water-Air	1 340	1,4	2 070	1,4	2 470	1,4
	Water-Water	1 340	1,6	2 070	1,6	2 470	1,6

The default values set out in Tables 1 and 2 above are typical for the segment of heat pumps with a SPF above the minimum threshold, meaning that heat pumps with SPF below 2,5 have not been taken into consideration when the typical values have been established <sup>(1)</sup>.

### 3.7. Remarks related to non-electrically driven heat pumps

The heat pumps that do not use electricity, either use liquid or gaseous fuel to drive the compressor, or use an ad/absorption process (driven by combustion of liquid or gaseous fuel or by use of geothermal/solarthermal energy or waste heat) are delivering renewable energy as long as the 'net seasonal primary energy ratio in active mode' ( $SPER_{net}$ ) is 115 % or larger than that value <sup>(2)</sup>.

### 3.8. Remarks related to heat pumps using exhaust air as energy source

Heat pumps using exhaust air as energy source use ambient energy, and such heat pumps therefore supply renewable energy. But simultaneously such heat pumps recover the energy in the exhaust air, which is not aerothermal energy according to the Directive <sup>(3)</sup>. It is therefore only the aerothermal energy that is counted as renewable energy. This is adjusted for by correcting the  $H_{HP}$  values for such heat pumps as set out in Section 3.6.

<sup>(1)</sup> This implies that Member States can consider the values set out in Tables 1 and 2 as average values of the electrically driven heat pumps that have SPF above the minimum 2,5.

<sup>(2)</sup> See Section 3.3.

<sup>(3)</sup> See Article 5(4), and definition of 'aerothermal energy' in Article 2(b) of the Directive.

**▼B****3.9. Remarks to air sourced heat pumps**

The  $H_{HP}$  values shown in Tables 1 and 2 above are based on  $H_{HE}$  values which includes not only the hours the heat pump is used, but also the hours that the supplementary heater is used. As the supplementary heater is outside of the system boundaries described in Section 3.4, the  $H_{HE}$  values for all air source heat pumps are appropriately adjusted to only account for the useful heat delivered by the heat pump itself. The adjusted  $H_{HP}$  figures are shown in Tables 1 and 2 above.

In the case of air sourced heat pumps with capacity reported for design conditions (and not for standard testing conditions), the  $H_{HE}$  values should be used <sup>(1)</sup>.

Only ambient air, i.e. outdoor air, can be the source of energy for an air-sourced heat pump.

**3.10. Remarks related to reversible heat pumps**

Firstly, reversible heat pumps in warm and to some extent average climates are often installed with the purpose of cooling the indoor environment, although they are also used to provide heating during the winter. As the cooling demand in the summer is higher than the heating demand in the winter, the rated capacity reflects the cooling demand rather than the need for heating. As the installed capacity is used as an indicator of heating demand, it implies that the statistics of installed capacity will not reflect the capacity installed for heating purposes. Moreover, reversible heat pumps are often installed in parallel to existing heating systems, implying that these heat pumps are not always used for heating purposes.

Both elements need appropriate adjustment. A conservative reduction <sup>(2)</sup> to 10 % for warm climate and 40 % for average climate is assumed in Tables 1 and 2 above. However, the real reduction is strongly dependent on national practices for providing heating systems, and national figures shall therefore be used where possible. The use of alternative figures should be submitted to the Commission, together with a report describing the method and data used. The Commission will, if necessary, translate the documents and publish them on its transparency platform.

**3.11. Renewable energy contribution from hybrid heat pump systems**

For hybrid heat pump systems, where the heat pump works in cooperation with other renewable energy technologies (e.g. solar thermal collectors used as pre-heaters), the accounting of renewable energy is at risk of

<sup>(1)</sup> These values are 1 336, 2 066 and 3 465 for warm, average and cold climate respectively.

<sup>(2)</sup> An Italian study (referred to on page 48 of 'Outlook 2011 — European Heat Pump Statistics') finds that in less than 10 % of the cases, heat pumps were the only installed heat generator. As reversible air-air heat pumps is the single most installed heat pump technology type (60 % of all installed units — mostly installed in Italy, Spain and France, as well as Sweden and Finland), it is important to adjust the figures appropriately. The Impact Assessment of Commission Regulation (EU) No 206/2012 of 6 March 2012 implementing Directive 2009/125/EC of the European Parliament and of the Council with regard to ecodesign requirements for air conditioners and comfort fans (OJ L 72, 10.3.2012, p. 7) assumes that EU wide, 33 % of reversible heat pumps are not used for heating. In addition one can assume that a large number of the 67 % of reversible heat pumps are only used partly for heating, as the heat pump is installed in parallel to another heating system. The proposed values are therefore appropriate to reduce the risk of over-estimation.

**▼B**

inaccuracy. Member States shall therefore ensure that the accounting of renewable energy from hybrid heat pump systems is correct, and in particular ensure that no renewable energy is accounted more than once.

### 3.12. Guidance on the development of more accurate methodologies

It is envisaged and encouraged that Member States do their own estimations for both SPF and  $H_{HP}$ . If improved estimations can be made, such national/regional approaches should be based on accurate assumptions, representative samples of sufficient size, resulting in a significantly improved estimate of renewable energy from heat pumps compared to the estimate obtained through the use of the method set out in this Decision. Such improved methodologies may be based on detailed calculation based on technical data taking into account, among other factors, year of installation, quality of installation, compressor type, operation mode, heat distribution system, bivalence point and the regional climate.

If measurements are only available at other system boundaries than the system boundary set out in Section 3.4, appropriate adjustments should be made.

Only those heat pumps with energy efficiency above the minimum threshold, as set out in Annex VII to the Directive, shall be included for the calculation of renewable energy for the purpose of the Directive.

Member States are invited, when alternative methodologies and/or values are used, to submit them to the Commission together with a report describing the method and data used. The Commission will, if necessary, translate the documents and publish them on its transparency platform.

## 4. CALCULATION EXAMPLE

The table below shows an example for a hypothetical Member State located in average climate conditions, which has 3 different heat pump technologies installed.

				Air to air (revers- ible)	Water to water	Exhaust Air to water
Calculation	Description	Variable	Unit			
	Capacity of heat pumps installed	$P_{rated}$	GW	255	74	215
	of which the SPF is above the minimum threshold	$P_{rated}$	GW	150	70	120
	Equivalent full load hours of operation	$H_{HP}$	h	852 (*)	► <b>C1</b> 2 070 ◀	660
$P_{rated} * H_{HP} = Q_{usable}$	Estimated total usable heat delivered by heat pumps	$Q_{usable}$	GWh	127 800	144 900	79 200
	the estimated average seasonal performance factor	SPF		2,6	3,5	2,6

▼ B

				Air to air (revers- ible)	Water to water	Exhaust Air to water
Calculation	Description	Variable	Unit			
$E_{RES} = Q_{usable}(1 - 1/SPF)$	Amount of renewable energy supplied per heat pump technology	$E_{RES}$	GWh	78 646	103 500	48 738
	Total amount of renewable energy supplied by heat pumps	$E_{RES}$	GWh		230 885	

(\*) The Member State in this hypothetical example did a survey of installed reversible air to air heat pumps and concluded that the equivalent of 48 % of the installed reversible heat pump capacity were used fully for heating, instead of the 40 % assumed in these guidelines. The  $H_{HP}$  value is therefore adjusted up from 710 hours, which assumes 40 % and set out in Table 1, to 852 hours, which is representative for the estimated 48 %.