

SCHEDULE 1

Regulation 2(4)

AMENDMENTS SUBJECT TO WHICH PART 3 OF BS 7114 IS TO BE READ FOR THE PURPOSES OF THESE REGULATIONS

Appendix A. Test paper

Substitute the following for Appendix A—

“A.1 Test paper

A.1.1 Requirements

When determined in accordance with BS EN ISO 536(1), after conditioning as specified in BS EN 20187(2), the grammage of the paper shall be $70\text{g/m}^2 \pm 5\text{g/m}^2$.

A.1.2 Conditioning prior to use

The test paper shall be conditioned at $(20 \pm 4)^\circ\text{C}$ and $(65 \pm 5)\%$ relative humidity for at least 24 h immediately prior to use.

A.2 Flame witness paper

The test paper shall comply with A.1.1 and shall also be subjected to the scorch test described in A.3 immediately prior to use. The highest sheet in the stack which shows no sign of discoloration after being subjected to the scorch test described shall be sheet ‘6’, ‘7’, ‘8’, ‘9’ or ‘10’.

A.3 Scorch test

A.3.1 Material

A.3.1.1 *Cigarette(s)*, untipped, of length $70\text{mm} \pm 4\text{mm}$, diameter $8.0\text{mm} \pm 0.5\text{mm}$ and mass $1.0\text{g} \pm 0.1\text{g}$, and having a smouldering rate of $12.0\text{ min} \pm 3.0\text{ min}$ over 50mm distance when determined in accordance with appendix D.

A.3.2 Apparatus

A.3.2.1 *Metal plate*, mass $225\text{g} \pm 1\text{g}$, dimensions as shown in figure A.1, with a rectangular hole cut in the centre (as shown). The mass of the plate shall be reduced to 225g by drilling holes symmetrically around the plate as necessary.

NOTE. The four holes in figure A.1 are shown as an example only.

A.3.3 Test specimen

Take twelve sheets of the paper, each at least $205\text{mm} \times 105\text{mm}$, number them consecutively (for identification) and assemble them in a stack, with the matt surfaces (if any) uppermost and sheet ‘1’ on the top.

-
- (1) BS EN ISO 536: 1997, the British Standard Specification for paper and board—determination of grammage, published on 15th February 1997. ISBN 0 580 25355 4.
- (2) BS EN 20187: 1993, the British Standard Specification for paper, board and pulps—standard atmosphere for conditioning and testing and procedure for monitoring the atmosphere and conditioning of samples, published on 15 December 1993. ISBN 0 580 21881 3.

Status: This is the original version (as it was originally made). This item of legislation is currently only available in its original format.

A.3.4 Procedure

A.3.4.1 Place the test specimen (A.3.3) on a flat, smooth, wooden surface and place the metal plate (A.3.2.1) on top of the stack (i.e. on top of sheet '1') so that the paper projects out around the edges. Light a cigarette (A.3.1.1) and allow it to burn at least 10mm along its length.

A.3.4.2 Place the burning cigarette on the exposed paper in a position which is at least 10mm from any edge of the rectangular hole in the metal plate, and so that it will burn inwards, and then remove the cigarette after 60 s.

Figure A.1. Metal plate for scorch test. All dimensions are in mm

Figure A.1. Metal plate for scorch test. All dimensions are in mm

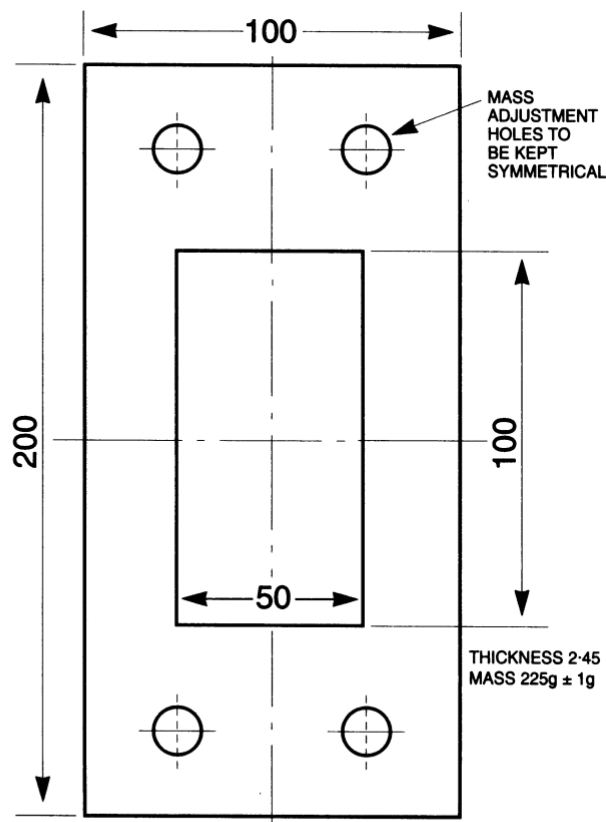

Figure A.1. Metal plate for scorch test. All dimensions are in mm

A.3.4.3 Repeat the operations described in A.3.4.2 a further four times, each time selecting a different position which is at least 10mm from any edge and at least 10mm from any scorch mark. If the cigarette has burnt more than 40mm along its length, light a new cigarette, allow it to burn 10mm and then use it for the next position.

A.3.4.4 Examine each sheet of paper and determine which is the highest sheet (i.e. that with the lowest number) which shows no sign of discoloration.”

Appendix D

After Appendix C, add a new appendix as follows—

“Appendix D. Method for determination of smouldering rate of cigarette

Condition the cigarette for at least 16 h, immediately before the test, at a temperature of $20^{\circ}\text{C}\pm 5^{\circ}\text{C}$ and a relative humidity of $50\%\pm 20\%$.

Mark the cigarette at 10mm and 60mm from the end to be lit. Ignite the cigarette and draw air through it until the tip glows brightly. Not less than 5mm and not more than 8mm of the cigarette shall be consumed in this operation. In draught-free air, impale the cigarette horizontally on a horizontal spike inserted not more than 13mm from the unlit end. Record the time taken for the cigarette to smoulder from the 6mm mark to the 60mm mark.”