STATUTORY INSTRUMENTS

1998 No. 2241

**MERCHANT SHIPPING
SAFETY**

The Merchant Shipping (Load Line) Regulations 1998

Made - - - - *8th September 1998*
Laid before Parliament *21st September 1998*
Coming into force - - *12th October 1998*

The Secretary of State, after consulting the persons referred to in section 86(4) of the Merchant Shipping Act 1995(1), in exercise of the powers conferred by section 85(1)(a) and (b), (3) and (5) to (7) and section 86(1) and (2) of that Act, and of all other powers enabling him in that behalf, hereby makes the following Regulations;

**PART I
GENERAL**

Citation and commencement

1. These Regulations may be cited as the Merchant Shipping (Load Line) Regulations 1998 and shall come into force on 12th October 1998.

Interpretation

2.—(1) In these Regulations, except where the context otherwise requires—

“the 1966 Convention” means the International Convention on Load Lines, 1966(2);

“alteration” includes deterioration;

“amidships” in relation to a ship means the middle of the ship’s length (L);

“appropriate load lines” means the load lines directed to be marked on a ship pursuant to regulation 7(2)(b), or in the case of a ship not surveyed under these Regulations, pursuant to an International Load Line Certificate (1966) which is in force, indicating the maximum depth to which the ship may be loaded in salt water in a particular zone or area and seasonal period;

(1) 1995 c. 21; sections 85 and 86 were amended by the Merchant Shipping and Maritime Security Act 1997 (c. 28), section 8.
(2) Cmnd. 3708.

“appropriate certificate” means—

- (a) in the case of a Convention-size ship, an International Load Certificate 1966, and
- (b) in the case of any other ship, a United Kingdom Load Line Certificate;

“appropriate marks” means the appropriate load lines, the deck-line and load line mark;

“Assigning Authority” means the Secretary of State or any person or organisation authorised by the Secretary of State for the purposes of these Regulations;

“Category A, B, C or D waters” means the waters specified as such in Merchant Shipping Notice No. M. 1504;

“clearance” includes transire;

“column stabilised” means, in relation to a mobile offshore drilling unit or a mobile offshore support unit, constructed with the main deck of the unit connected to its underwater hull or footings by columns or caissons;

“Convention country” means a country or territory which is either—

- (a) a country the Government of which is party to the 1966 Convention; or
- (b) a territory to which the 1966 Convention extends;

“Convention-size” in relation to a ship, means in the case of an existing ship, of not less than 150 gross tons (ascertained in accordance with the law in force on 21st July 1968), and in the case of a new ship, of not less than 24 metres in length;

“exclusive surveyor” means a surveyor appointed by and working exclusively for an Assigning Authority;

“freeboard” means the distance measured vertically downwards at amidships from the upper edge of the deck-line described in regulation 16 to the position at which the upper edge of the load line appropriate to the freeboard is to be marked;

“freeboard deck” means the deck from which the freeboards assigned to the ship are calculated, being—

- (a) the uppermost complete deck exposed to weather and sea, which has permanent means of closing all openings open to the weather, and below which all openings in the sides of the ship are fitted with permanent means of watertight closing; or
- (b) at the request of the owner and subject to the approval of the Secretary of State, a deck lower than that described in subparagraph (a) above, it being a complete and permanent deck which is continuous both in a fore and aft direction at least between the machinery space and peak bulkheads of the ship, and athwartships.

When this lower deck is stepped the lowest line of the deck and the continuation of that line parallel to the upper part of the deck is taken as the freeboard deck;

“international voyage” means a voyage between—

- (a) a port in the United Kingdom and a port outside the United Kingdom; or
- (b) a port in a Convention country (other than the United Kingdom) and a port in any other country or territory (whether a Convention country or not) which is outside the United Kingdom;

“length” and “(L)” in relation to a ship means the greater of the following distances, measured at and along the waterline—

- (a) the distance between the foreside of the stem and the axis of the rudder stock; or
- (b) a distance measured from the foreside of the stem, being 96 per cent of the distance between that point and the aft side of the stern.

The waterline referred to in this definition shall be at 85 per cent of the least moulded depth of the ship. In the case of a ship having a rake of keel, the waterline shall be parallel to the designed waterline;

“load line” means a mark on the ship indicating the maximum depth to which a ship may be loaded;

“local fisheries committee” means a local fisheries committee constituted under the Sea Fisheries Regulation Act 1966(3);

“Maritime and Coastguard Agency” means the Maritime and Coastguard Agency, an Executive Agency of the Department of the Environment, Transport and the Regions;

“material date” for the purposes of the definitions of a new and an existing ship is—

- (a) in relation to a ship whose parent country is a Convention country other than the United Kingdom, the date on which the 1966 Convention entered into force for that country; and
- (b) in relation to any other ship, the 21st July 1968;

“Merchant Shipping Notice” means a Notice described as such and issued by the Maritime and Coastguard Agency, and any reference to a particular Merchant Shipping Notice includes a reference to any Merchant Shipping Notice amending that Notice;

“mobile offshore drilling unit” means a ship capable of engaging in drilling operations for the exploration or exploitation of resources beneath the sea bed such as liquid or gaseous hydrocarbons, sulphur or salt;

“mobile offshore support unit” means a ship used in connection with the offshore petroleum industry to provide ancillary services such as accommodation, cranes or repair facilities;

“moulded depth” in relation to a ship means the vertical distance measured from the top of the keel to the top of the freeboard deck beam at side, except that—

- (a) in the case of a wood or composite ship, it shall be measured from the lower edge of the keel rabbet;
- (b) if the form at the lower part of the midship section of the ship is of a hollow character or if thick garboards are fitted, it shall be measured from the point where the line of the flat of the bottom continued inwards cuts the side of the keel;
- (c) in the case of a ship having rounded gunwales it shall be measured to the point of intersection of the moulded lines of the deck and side shell plating, the lines extending as though the gunwale were of angular design; and
- (d) if the freeboard deck is stepped and the raised part of the deck extends over the point at which the moulded depth is to be determined, it shall be measured to a line of reference extending from the lower part of the deck along a line parallel to the raised part of the deck;

“near-coastal voyage” means a voyage during which the vessel is never more than 150 nautical miles from a safe haven in the United Kingdom, or never more than 30 nautical miles from a safe haven in the Republic of Ireland;

“new ship” means a ship whose keel is laid, or which is at a similar stage of construction, on or after the material date; and “existing ship” means a ship which is not a new ship;

“non-United Kingdom ship” means any ship other than a United Kingdom ship within the meaning of section 85(2) of the Merchant Shipping Act 1995;

“parent country”, in relation to a ship, means the country or territory in which the ship is registered or, if the ship is not registered anywhere, it means the country or territory whose flag the ship flies;

“pleasure vessel” means—

- (a) any ship which at the time it is being used is—
 - (i) (a) in the case of a ship wholly owned by an individual or individuals, used only for the sport or pleasure of the owner or the immediate family or friends of the owner; or
 - (b) in the case of a ship owned by a body corporate, used only for sport or pleasure and on which the persons are employees or officers of the body corporate, or their immediate family or friends; and
 - (ii) on a voyage or excursion for which the owner does not receive money for or in connection with operating the ship or carrying any person, other than as a contribution to the direct expenses of the operation of the ship incurred during the voyage or excursion; or
- (b) any ship wholly owned by or on behalf of a members' club formed for the purpose of sport or pleasure which, at the time it is being used, is used only for the sport or pleasure of members of that club or their immediate family; and for the use of which any charges levied are paid into club funds and applied for the general use of the club; and
- (c) in the case of any ship referred to in paragraph (a) or (b) above no other payments are made by or on behalf of users of the ship, other than by the owner.

In this definition “immediate family” in relation to an individual means, the husband or the wife of the individual, and a relative of the individual or the individual’s husband or wife, and “relative” means brother, sister, ancestor or lineal descendant;

“rake of keel” means the inclination of the keel to a horizontal baseline;

“sailing ship” means a ship designed to carry sail, whether as the sole means of propulsion, or as a supplementary means;

“sea” does not include Category A, B, C or D waters;

“surveyor” means a surveyor appointed by the Secretary of State or an exclusive surveyor of any other Assigning Authority;

“valid Convention certificate” means an International Load Line Certificate (1966) or an International Load Line Exemption Certificate issued under the 1966 Convention which is in force;

“watertight” in relation to any part of the ship, means capable of preventing the passage of water in any direction.

(2) In determining, for the purposes of the definition of an international voyage what are the ports between which a voyage is made no account shall be taken of any deviation by a ship from its intended voyage which is solely due to stress of weather or any other circumstance which neither the master nor the owner nor the charterer (if any) of the ship could have prevented or forestalled.

(3) Any reference in these Regulations to the 1966 Convention includes any amendment of it considered by the Secretary of State to be relevant from time to time, and specified in a Merchant Shipping Notice.

(4) In these Regulations—

- (a) a reference to a numbered Part is, unless otherwise stated, a reference to the Part of that number in these Regulations;
- (b) a reference to a numbered regulation is, unless otherwise stated, a reference to the regulation of that number in these Regulations; and
- (c) a reference in a regulation to a numbered paragraph is, unless otherwise stated, a reference to the paragraph of that number in that regulation.

(5) Any approval given pursuant to these Regulations shall be given in writing and shall specify the date on which it takes effect and the conditions (if any) on which it is given.

Repeals and revocations

3.—(1) The following provisions of the Merchant Shipping Act 1995 are hereby repealed:

- (a) section 89;
- (b) in section 261(4)(a), the words “89 (and Schedule 3),”;
- (c) in section 306(3) the words “paragraph 29 of Schedule 3”; and
- (d) Schedule 3.

(2) The following Instruments are hereby revoked, namely—

- the Merchant Shipping (Load Line) (Transitional Provisions) Regulations 1968(4);
- the Merchant Shipping (Load Line) Rules 1968(5);
- the Merchant Shipping (Load Line) (Length of Ship) Regulations 1968(6);
- the Merchant Shipping (Load Line) (Deck Cargo) Regulations 1968(7);
- the Merchant Shipping (Load Line) (Exemption) Order 1968(8);
- the Merchant Shipping (Load Line) (Amendment) Rule 1970(9);
- the Merchant Shipping (Load Line) (Particulars of Depth of Loading) Regulations 1972(10);
- the Merchant Shipping (Load Lines Convention) (Various Countries Order) 1977(11);
- the Merchant Shipping (Load Line) (Amendment) Rules 1979(12);
- the Merchant Shipping (Load Lines Convention) (Countries) Order 1981(13);
- the Merchant Shipping (Load Line) (Exemption) (Amendment) Order 1990(14);
- the Merchant Shipping (Load Line) (Amendment) Rules 1990(15);
- the Merchant Shipping (Load Line) (Exemption) (Amendment) Order 1991(16) and
- the Merchant Shipping (Load Line) Act 1967 (Unregistered Ships) Order 1993(17).

Application

4.—(1) These Regulations apply to United Kingdom ships wherever they may be and to other ships while they are within United Kingdom waters, except—

- (a) ships of war;
- (b) ships solely engaged in fishing;
- (c) pleasure vessels;
- (d) ships which do not go to sea; and

-
- (4) S.I.1968/1052.
 - (5) S.I. 1968/1053.
 - (6) S.I. 1968/1072.
 - (7) S.I. 1968/1089.
 - (8) S.I. 1968/1116.
 - (9) S.I. 1970/1003.
 - (10) S.I. 1972/1841.
 - (11) S.I. 1977/1875.
 - (12) S.I. 1979/1267.
 - (13) S.I. 1981/236.
 - (14) S.I. 1990/365.
 - (15) S.I. 1990/2128.
 - (16) S.I. 1991/1298.
 - (17) S.I. 1993/1994.

- (e) ships under 80 tons register falling within one of the classes specified in paragraph (2) engaged solely in the coasting trade, and, subject to paragraph (3), not carrying cargo—
- (2) Those classes are—
 - (a) tugs or salvage ships;
 - (b) hopper barges or dredgers;
 - (c) ships used by or on behalf of—
 - (i) a general or local lighthouse authority for the purpose of the authority's functions as such;
 - (ii) a Government department for fishery protection purposes, or a local fisheries committee for the regulation of sea fisheries within its district;
 - (iii) a Government department for fishery or scientific research; or
 - (iv) the Secretary of State for Defence for the purpose of ensuring safety in the use of firing ranges or weapons at sea; and
 - (d) ships in respect of which passenger certificates are in force specifying limits beyond which the ship must not ply, and which operate solely within those limits;
 - (e) ships carrying not more than 12 passengers for sport or pleasure on a voyage in the course of which they are at no time more than 3 miles from land nor more than 15 miles from their point of departure, unless the point of departure lies within Category A, B, C or D waters, when the distance of 15 miles shall be measured from the seaward boundary of such limits.
- (3) A ship referred to in paragraph (1)(e) falling within the class in paragraph (2)(d) shall be excepted from the provisions of these Regulations while carrying cargo in accordance with the terms, if any, of the ship's passenger certificate expressly authorising the carriage of cargo.

Exemptions

- 5.—(1) Subject to paragraph (4) below the Secretary of State may exempt from these Regulations—
- (a) any ship which embodies features of a novel kind if the development of those features and their incorporation in ships engaged on international voyages might be seriously impeded if the ship had to comply with all the requirements of these Regulations.
 - (b) any ship plying on international voyages between near neighbouring ports if—
 - (i) in his opinion the sheltered nature and condition of the voyages makes it unreasonable or impracticable to apply these Regulations; and
 - (ii) he is satisfied the Government of the other country (or, as the case may be, of each of the other countries) concurs in that opinion.
 - (2) Subject to paragraph (4) below the Secretary of State may exempt from these Regulations:
 - (a) a ship which is not a Convention-size ship;
 - (b) any other ship which does not ply on international voyages.
 - (3) Subject to paragraph (4) below, where a United Kingdom ship does not normally ply on international voyages but is, in exceptional circumstances, required to undertake a single international voyage, the Secretary of State may exempt the ship while engaged on that voyage.
 - (4) Any exemption conferred under this regulation may be conferred subject to such conditions as the Secretary of State thinks fit; and, where any such exemption is conferred subject to conditions, the exemption shall not have effect unless those conditions are complied with.

General compliance

6.—(1) Subject to any exemption conferred under these Regulations, a ship shall not proceed, or attempt to proceed, to sea unless—

- (a) it has been surveyed in accordance with these Regulations;
- (b) it is marked with the appropriate marks;
- (c) it complies with the conditions of assignment applicable to it; and
- (d) the information required by regulation 32 and 33 is provided for the guidance of the master of the ship.

(2) Paragraph (1) above does not apply to a non-United Kingdom ship in respect of which a valid Convention certificate is produced.

(3) A ship shall not be so loaded that—

- (a) if the ship is in salt water and has no list the appropriate load line on each side of the ship is submerged; or
- (b) in any other case, the appropriate load line on each side of the ship would be submerged if the ship were in salt water and had no list.

(4) A ship shall not proceed to sea when it is in contravention of paragraph (3).

(5) Before any ship proceeds to sea from any port in the United Kingdom, the master of that ship shall produce to an officer of customs from whom a clearance for the ship is demanded for an international voyage:

- (i) an appropriate certificate;
- (ii) an International Load Line Exemption Certificate issued under the Convention; or
- (iii) a United Kingdom Load Line Exemption Certificate issued pursuant to regulation 12,

as the case may be, which is in force in relation to the ship.

(6) For the purpose of this regulation, where a valid Convention certificate cannot be produced the freeboard deck and the freeboard shall be determined in accordance with these Regulations and the appropriate load line shall be the maximum depth to which the ship may be loaded in salt water.

PART II

SURVEYS AND CERTIFICATES

Assignment of freeboards

7.—(1) The Assigning Authority shall assign freeboards to a United Kingdom ship in accordance with the requirements of these Regulations.

(2) The Assigning Authority shall—

- (a) determine the particulars of the freeboards to be assigned;
- (b) determine which of the load lines described in Part III are to be marked on the sides of the ship in accordance with the requirements of that Part;
- (c) determine the position where the load lines, the deck-line and the load line mark are to be so marked; and
- (d) complete a copy of the record of particulars relating to the conditions of assignment.

(3) Where a passenger ship is marked with subdivision load lines, and the lowest of those lines is lower than the line which is the appropriate load line then that subdivision load line shall have effect as if it is the appropriate load line for the purposes of these Regulations.

Initial, periodical and annual surveys

8.—(1) A United Kingdom ship shall be subject to the surveys specified below:

- (a) An initial survey before the ship is put into service, which shall include a complete inspection of its structure and equipment as required by these Regulations. This survey shall be such as to ensure that the arrangements, materials and scantlings comply fully with the requirements of these Regulations.
- (b) A renewal survey at intervals not exceeding five years, which shall be such as to ensure that the structure, equipment, arrangements, materials and scantlings comply fully with the requirements of these Regulations.
- (c) An annual survey within three months either way of each annual anniversary date of the load line certificate, to ensure that no alterations have been made to the hull or superstructures which would affect the basis on which the position of the load line had been assigned and that the fittings and appliances for the protection of openings, the guard rails, the freeing ports and the means of access to crew's quarters are maintained in an effective condition.

(2) The owner and master shall ensure that after any of the surveys referred to in paragraph (1) has been completed, no material alteration is made to the ship, its structure and equipment, without the approval of the Assigning Authority.

(3) After a satisfactory annual survey referred to in paragraph (1)(c), the surveyor shall endorse the International Load Line Certificate (1966) or, as the case may be, the United Kingdom Load Line Certificate, accordingly.

Issue of appropriate certificates

9.—(1) Subject to the provisions of regulation 10, the Assigning Authority shall issue the appropriate certificate in respect of a United Kingdom ship which has been surveyed and marked in accordance with these Regulations.

(2) If the certificate is an International Load Line Certificate (1966) it shall be in the form prescribed by the 1966 Convention.

(3) If the certificate is a United Kingdom Load Line Certificate it shall be in the form prescribed in Schedule 8 of Merchant Shipping Notice MSN 1701 (M).

(4) Subject to any exemption conferred by or under these Regulations, a ship shall not proceed, or attempt to proceed, to sea unless the appropriate certificate is in force in respect of that ship.

(5) The Secretary of State may request, through a proper officer or otherwise, the Government of a Convention country to survey a United Kingdom ship and, if satisfied that the requirements of the Convention are complied with, to issue or authorise the issue, in respect of this ship, an International Load Line Certificate (1966). A certificate issued in accordance with such a request shall contain a statement that it has been so issued, and shall have the same effect as if it was issued by the Secretary of State.

(6) In the case of a ship that has transferred from the registry of the Government of another country to the United Kingdom registry, the Assigning Authority, subject to such survey requirements it considers to be necessary may, and in the case of a ship to which Council Regulation EEC No. 613/91(18) applies shall, issue an International Load Line Certificate (1966) for a period to be

(18) O.J. No. L.68, 15.3.91, p. 1.

determined by the Assigning Authority, but for not longer than the period of validity of the certificate issued by or on behalf of the Government of that other country if satisfied that—

- (a) the ship has already been subjected to satisfactory initial, periodical, annual and additional surveys, as appropriate;
- (b) the condition of the ship, including its structure and equipment, have been maintained so as to comply with the requirements of the 1966 Convention applicable to the ship;
- (c) after any of the surveys referred to in subparagraph (a) above have been completed, no material change has been made to the ship, including its structure and equipment, subject to such surveys, without the approval of the administration of that State; and
- (d) that in the case of a ship to which Council Regulation EEC No. 613/91 applies, the intact stability information approved by or on behalf of the Government of that other country is in English and complies with the requirements of the International Maritime Organisation's Resolution A.167(ES.IV).

Duration and extension of certificates

10.—(1) The duration of any certificate issued under these Regulations shall not exceed five years from the date of completion of the survey referred to in regulation 8(1)(a) or (b). Subject to paragraph (2), this duration may be extended for a period not exceeding 5 months if—

- (a) the load line certificate is still in force;
- (b) the ship has been surveyed in accordance with regulation 8(1)(b), and complies with the requirements of these Regulations; and
- (c) it is not reasonably practicable to issue a new certificate before the expiry of the current certificate.

(2) No such extension shall have effect unless the date to which the period of validity is extended and the place at, and the date on, which such extension was given are endorsed by the Assigning Authority on the current certificate.

(3) The period of validity of any load line certificate coming into effect immediately on the expiry of a certificate extended pursuant to this regulation shall not exceed a period of 5 years commencing on the date of completion of the survey referred to in regulation 8(1)(b).

Cancellation of certificates

11.—(1) The Secretary of State may cancel a load line certificate issued in respect of a United Kingdom ship—

- (a) if satisfied that—
 - (i) the certificate was issued on false or erroneous information;
 - (ii) the ship ceases to comply with the conditions of assignment relating to it;
 - (iii) the structural strength of the ship is reduced to an extent that the ship is unsafe; or
 - (iv) information on the basis of which freeboards were assigned to the ship was incorrect in a material particular;
- (b) if the certificate is not endorsed in accordance with the requirements of regulation 8(1)(c) to show that the ship has been surveyed in accordance with that regulation,
- (c) if a new certificate is issued in respect of the ship; or
- (d) if the ship ceases to be a United Kingdom ship.

(2) The Secretary of State shall notify the owner in writing of the cancellation specifying the grounds for cancellation and may require any certificate issued under these Regulations which has

expired or been cancelled, to be delivered up as he directs. Such notice shall not take effect unless the owner has been given the opportunity to make representations, unless the Secretary of State considers that urgent safety considerations require this.

Issue of exemption certificates

12.—(1) Where a ship is exempted under regulation 5(1) or (3) an “International Load Line Exemption Certificate” in the form prescribed by the 1966 Convention shall be issued in respect of the ship by the Secretary of State; and

(2) Where a ship is exempted under regulation 5(2), a “United Kingdom Load Line Exemption Certificate” shall be issued in respect of the ship by the Secretary of State which shall state the conditions with which the ship is to comply.

(3) Except in so far as the nature or terms of any such exemption require the contrary:

- (a) the ship shall be assigned freeboards in accordance with regulation 7;
- (b) shall be subject to surveys in accordance with regulation 8; and
- (c) regulations 9 to 11 shall apply in relation to the certificate of exemption as they apply in relation to load line certificates,

subject to the substitution, for references in the said regulations to an Assigning Authority, of references to the Secretary of State.

Publication of load line certificate and notification of draughts

13.—(1) Where an appropriate certificate or an Exemption Certificate is issued in respect of a United Kingdom ship, the owner and master of the ship shall ensure that it is kept legible and posted up in some conspicuous place on board the ship.

(2) Before any United Kingdom ship leaves any dock, wharf, harbour or other place for the purpose of proceeding to sea, the master of the ship shall, subject to paragraph (4), ensure a notice is posted up in some conspicuous place on board the ship, in a form and containing such particulars relating to the depth to which the ship is loaded as is specified in Schedule 7 in Merchant Shipping Notice MSN 1701(M).

(3) Where a notice has been posted up in accordance with paragraph (2), the master of the ship shall cause it to be kept posted and legible until the ship arrives at some other dock, wharf, harbour or place.

(4) Paragraph (2) does not apply to ships employed on a near-coastal voyage.

Non-United Kingdom ships

14.—(1) The Secretary of State may, at the request of a Government of a Convention country survey a ship registered in that country and if satisfied that the requirements of the 1966 Convention are complied with and that a survey has been satisfactorily completed in accordance with these Regulations, issue to the ship an International Load Line Certificate (1966) and, where appropriate, endorse such certificates in accordance with the requirements of the 1966 Convention. A certificate issued in accordance with such a request shall contain a statement that it has been so issued and shall have the same effect as if it was issued by that Government and not by the Secretary of State.

(2) A United Kingdom Load Line Certificate may be issued to a non-United Kingdom ship which has been surveyed and marked in accordance with these Regulations.

(3) Subject to paragraph (4), a certificate issued under paragraph (2) shall be subject to the same conditions and have the same effect as a similar certificate issued to a United Kingdom ship.

(4) Any certificate issued under paragraph (2) in respect of a ship registered in a Convention country shall be valid only so long as the ship is not plying on international voyages, and shall be cancelled by the Secretary of State if he has reason to believe that the ship is plying on international voyages.

PART III

LOAD LINES AND MARKS

Marking

15.—(1) The load line directed to be marked on the ship pursuant to regulation 7(2)(b), the deckline and the load line mark shall be marked on each side of the ship in accordance with the directions of the Assigning Authority and the requirements of this Part.

(2) Where an Exemption Certificate is issued in association with the assignment of special freeboards which are less than those required by regulation 29, the ship shall be marked in accordance with regulation 22(4).

Deck-line

16.—(1) The deck-line shall consist of a horizontal line 300 millimetres in length and 25 millimetres in width and shall be marked amidships on each side of the ship so as to indicate the position of the freeboard deck.

(2) Subject to paragraph (3), the deck-line shall be marked in such a position on the side of the ship that its upper edge passes through the point amidships where the continuation outwards of the upper surface of the freeboard deck, or of any sheathing of that deck, intersects the outer surface of the shell of the ship as shown in Figure 1.

(3) Where the design of the ship, or other circumstances, render it impracticable to mark the deck-line in accordance with paragraph (2) the Assigning Authority may direct that it be marked by reference to another fixed point as near as practicable to the position described in paragraph (2).

Load line mark

17. The load line mark as shown in Figure 2 shall consist of a ring 300 millimetres in outside diameter and 25 millimetres wide, intersected by a horizontal line 450 millimetres long and 25 millimetres wide the upper edge of which passes through the centre of the ring. The centre of the ring shall be marked amidships vertically below the deck-line so that, except as otherwise provided in regulation 31, the distance from the centre of the ring to the upper edge of the deck-line is equal to the Summer freeboard assigned to the ship.

Load lines

18.—(1) Except as otherwise provided for in paragraph (3), the load lines shown in Figure 2 shall consist of horizontal lines of 230 millimetres in length and 25 millimetres in width extending forward or abaft of a vertical line 25 millimetres in width marked 540 millimetres forward of the centre of the ring of the load line mark and at right angles to that line. The individual load lines shall be as follows—

- (a) the *Summer load line*, which shall extend forward of the said vertical line, and shall correspond horizontally with the line passing through the centre of the ring of the load line mark, and shall be marked S;
- (b) the *Winter load line*, which shall extend forward of the vertical line, and be marked W;

- (c) the *Winter North Atlantic load line*, which shall extend forward of the vertical line, and be marked WNA;
 - (d) the *Tropical load line*, which shall extend forward of the vertical line, and be marked T;
 - (e) the *Fresh Water load line*, which shall extend abaft the vertical line, and be marked F; and
 - (f) the *Tropical Fresh Water load line*, which shall extend abaft the vertical line and be marked TF.
- (2) The maximum depth to which a ship may be loaded in relation to a load line referred to in paragraph (1) shall be the depth indicated by the upper edge of the appropriate load line.
- (3) In the case of a sailing ship—
- (a) the *Summer load line* shall consist of the line passing through the centre of the ring of the load line mark; and
 - (b) the *Winter North Atlantic load line* and *Fresh Water load line* only shall be marked on the ship as shown in Figure 3.

Timber load lines

19.—(1) Timber load lines shall consist of horizontal lines of the dimensions specified in respect of such lines in regulation 18(2), extending abaft or forward of a vertical line 25 millimetres in width and marked 540 millimetres abaft the center of the ring of the load line mark and at right angles to that line as shown in Figure 4 and individual Timber load lines shall be as follows—

- (a) the *Summer Timber load line*, which shall extend abaft the said vertical line and be marked LS;
 - (b) the *Winter Timber load line*, which shall extend abaft the vertical line and be marked LW;
 - (c) the *Winter North Atlantic Timber load line*, which shall extend abaft the vertical line and be marked LWNA;
 - (d) the *Tropical Timber load line*, which shall extend forward of the vertical line and be marked LT;
 - (e) the *Fresh Water Timber load line*, which shall extend forward of the vertical line and be marked LF; and
 - (f) the *Tropical Fresh Water Timber load line*, which shall extend forward of the vertical line and be marked LTF.
- (2) The maximum depth to which a ship may be loaded in relation to a Timber load shall be the depth indicated by the upper edge of the appropriate Timber load line.

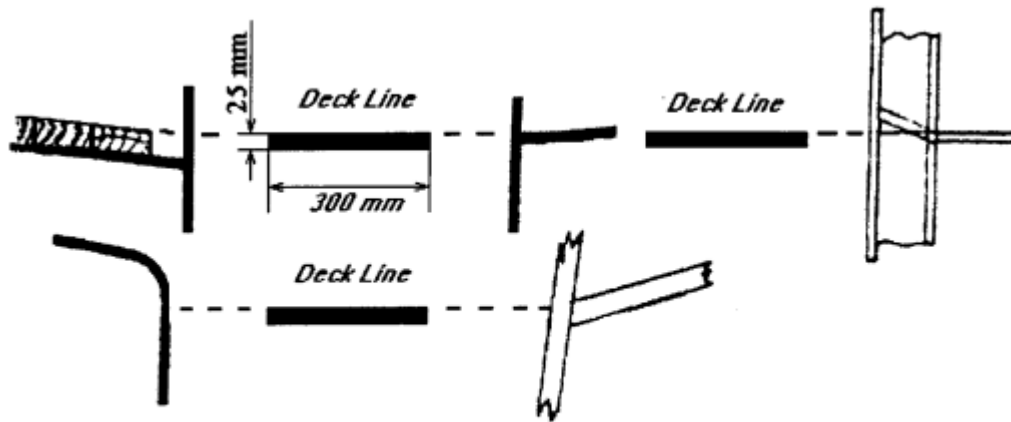

Figure 1: Deck-line

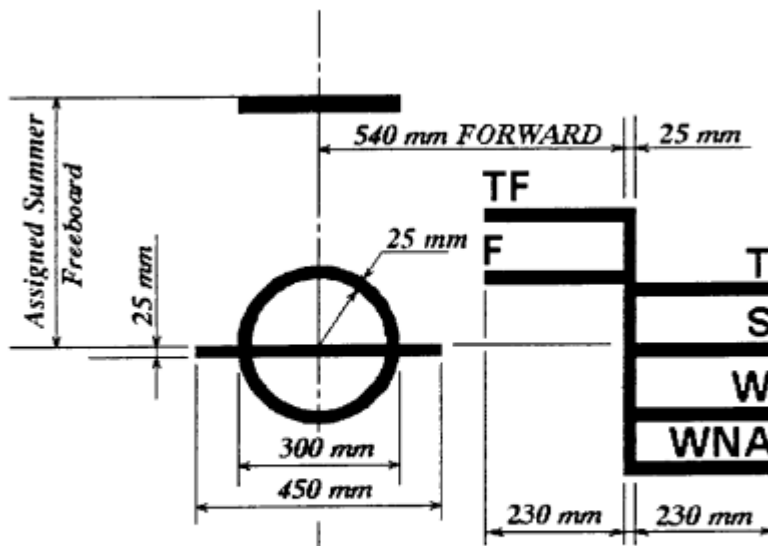

Figure 2: Load Line Mark and Lines to be used with this mark

Status: This is the original version (as it was originally made). This item of legislation is currently only available in its original format.

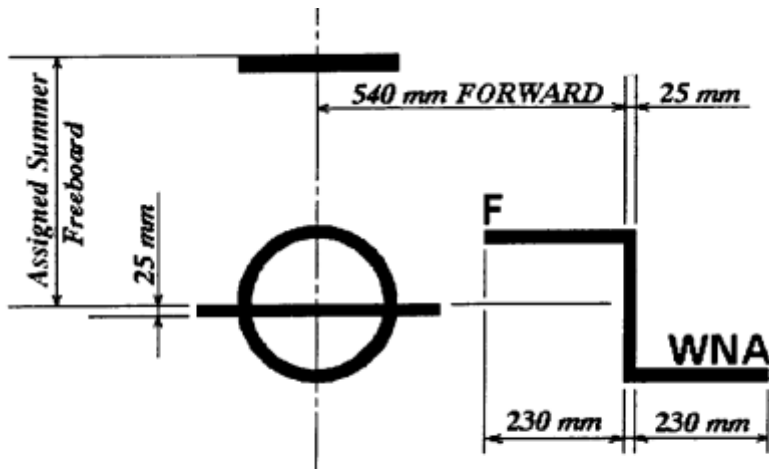

Figure 3: Load Line Mark and Lines for Sailing Ships

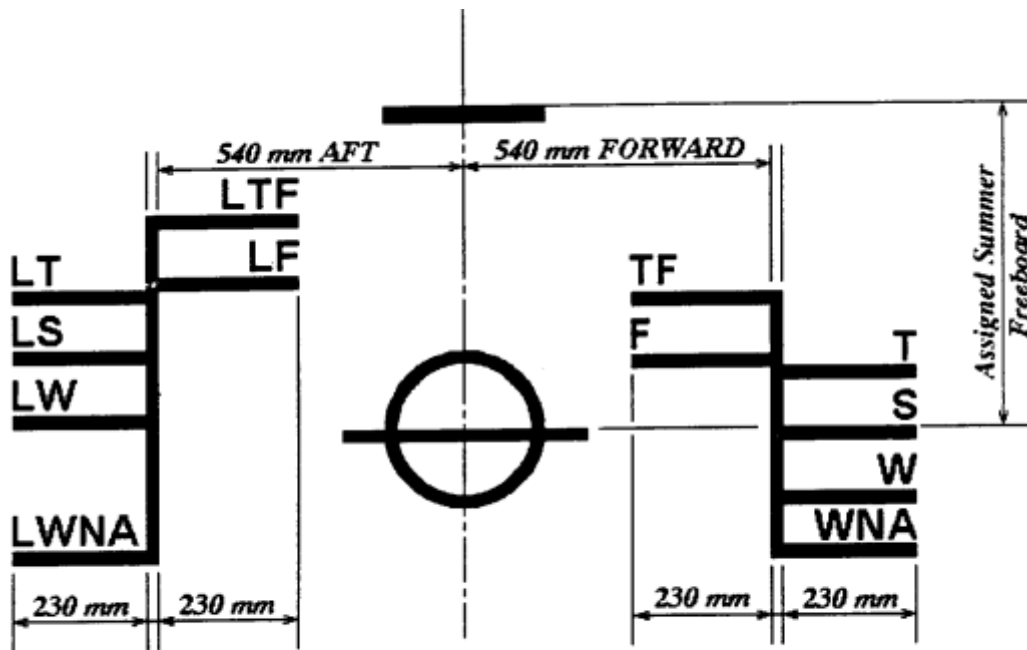

Figure 4: Timber Load Line Mark and Lines to be used with this mark

Appropriate load line

20. The appropriate load line in respect of a ship at any particular zone or area and seasonal period shall be ascertained in accordance with the provisions of Schedule 1 in Merchant Shipping Notice MSN 1701(M).

Position of load lines

21. Each load line shall be marked in such a position on each side of the ship that the distance measured vertically downwards from the upper edge of the deck-line to the upper edge of the load line is equal to the freeboard assigned to the ship which is appropriate to that load line.

Method of marking

22.—(1) The appropriate marks shall be marked in such a manner as to be plainly visible.

(2) If the sides of the ship are of metal the appropriate marks shall be cut in, centre punched or welded; if the sides of the ship are of wood the marks shall be cut into the planking to a depth of not less than 3 millimetres; if the sides are of other materials to which the foregoing methods of marking cannot effectively be applied the marks shall be permanently affixed by bonding or some other effective method.

(3) The appropriate marks shall be painted in white or yellow if the background is dark, and in black if the background is light.

(4) Where a ship is assigned special freeboards which are less than those required by regulation 29 the load line mark shall comply with the requirements of regulation 17, except that it shall be painted in red on a contrasting background. If the red marking is in addition to the load line mark required by regulation 17 it shall be placed with the centre of the ring 762 mm abaft the load line mark.

Authorisation of removal, etc., of appropriate marks

23. After the appropriate marks have been made on a ship,

- (a) it shall be the duty of the owner and master to keep the ship so marked; and
- (b) the marks shall not be concealed, removed, altered, defaced or obliterated except with the authority of the Assigning Authority.

Mark of Assigning Authority

24.—(1) The identity of the Assigning Authority may be marked alongside the load line ring either above the horizontal line which passes through the centre of the ring, or above and below it.

(2) Such a mark shall consist of not more than four initials each measuring approximately 115 millimetres in height and 75 millimetres in width.

PART IV

CONDITIONS OF ASSIGNMENT

Requirements relevant to the assignment of freeboards

25. Freeboards assigned under these Regulations shall comply with the requirements applicable to the ship of Schedule 2 in Merchant Shipping Notice MSN 1701(M).

Compliance with conditions of assignment

26.—(1) Except as otherwise provided for in paragraph (2), a ship will cease to comply with the conditions of assignment—

- (a) if at any time after the assignment of freeboards there has been any alteration of the hull, superstructures, fittings or appliances of the ship such that—

- (i) a requirement applicable to the ship under regulation 25 is not complied with; or
 - (ii) it differs in a material respect from the record of particulars provided in accordance with regulation 27; or
- (b) if the record of particulars is not on board in accordance with regulation 27(2).
- (2) A ship shall be taken to comply with the conditions of assignment notwithstanding an alteration referred to in paragraph (1)(a) if—
- (a) amended freeboards appropriate to the condition of the ship have been assigned, the ship has been marked with these load lines and a new certificate issued to the owner of the ship accordingly; or
 - (b) the alteration has been inspected by a surveyor on behalf of the Assigning Authority and that Authority is satisfied that the alteration is not such as to require any change in the freeboards assigned to the ship, and full particulars of the alteration together with the date and place of his inspection have been endorsed by the surveyor on the record referred to in regulation 27(1).

Record of particulars

27.—(1) The record of particulars shall be provided on the ship in a form given in Schedule 3 of Merchant Shipping Notice MSN 1701(M).

- (2) The record shall be furnished by the Assigning Authority and be retained on board at all times.

PART V

FREEBOARDS

Types of freeboard

28. The freeboards that can be assigned to a ship under these Regulations are the Summer freeboard; Tropical freeboard; Winter freeboard; Winter North Atlantic freeboard; Fresh Water freeboard and Tropical Fresh Water freeboard. In the case of ships carrying Timber the freeboards that may be assigned are Summer Timber freeboard; Winter Timber freeboard; Winter North Atlantic Timber freeboard; Tropical Timber freeboard; Fresh Water Timber freeboard and Tropical Fresh Water Timber freeboard.

Determination of freeboards

29.—(1) Except as otherwise provided for in regulation 30 the freeboards assigned to a new ship shall be determined in accordance with the provisions of Schedule 3 in Merchant Shipping Notice MSN 1701(M).

- (2) The freeboards assigned to an existing ship shall be determined in accordance with the provisions applicable to the ship under the law in force immediately before 21st July 1968:

Provided that if an existing ship has been so constructed or modified as to comply with all the requirements of Schedule 2 of Merchant Shipping Notice MSN 1701(M) applicable to a new ship of her type, and application is made for the assignment to her of freeboards determined in accordance with Schedule 4 of that Merchant Shipping Notice, such freeboards shall be assigned to her.

Greater than minimum freeboards

30.—(1) A freeboard determined in accordance with regulation 29 is the minimum freeboard that may be assigned to the ship.

(a) (2) (a) Subject to subparagraph (b) below the Assigning Authority may however, if it is satisfied that the ship complies with the requirements of these Regulations, assign freeboards (other than Timber freeboards) which exceed the minimum freeboards by such an amount as it may determine.

(b) Timber freeboards shall not be assigned to a ship to which greater than minimum freeboards have been assigned.

(3) Where a freeboard greater than the minimum is assigned to a ship and the load line appropriate to that freeboard corresponds to, or is lower than, the position at which the lowest of the load lines appropriate to minimum freeboards would be marked then—

(a) load lines only appropriate to the greater than minimum Summer freeboard and Fresh Water freeboard shall be marked on the sides of the ship;

(b) the load line appropriate to the greater than minimum Summer freeboard shall be known as the “All Seasons load line” and shall consist of the horizontal line intersecting the load line mark;

(c) the vertical line described in regulation 18 shall be omitted;

(d) subject to the provisions of subparagraph (c) above, the Fresh Water load line shall be as described in regulation 18(1) and be marked accordingly.

Special position of deck-line: correction of freeboards

31. In any ship where the deck line is marked in accordance with regulation 16(3), the freeboards assigned to the ship shall be corrected to allow for the vertical distance by which the position of the deck-line is altered by virtue of that paragraph. The reference point to which the deck-line has been so marked, and the identity of the deck which has been taken as the freeboard deck, shall be specified in the load line certificate issued to the ship.

PART VI

INFORMATION FOR THE MASTER

Information as to stability of ships

32.—(1) The owner of every ship to which these Regulations apply shall provide, for the guidance of the master, information relating to the stability of the ship in accordance with this regulation. The information shall be in the form of a book which shall be kept on the ship at all times in the custody of the master.

(2) In the case of a United Kingdom ship this information shall include all matters specified in Schedule 6 in Merchant Shipping Notice MSN 1701(M), and be in the form required by that Schedule. This information shall also be in accordance with the requirements of paragraphs (3), (4) and (5).

(3) Subject to paragraph (4), this information shall be based on the determination of stability taken from an inclining test carried out in the presence of a surveyor appointed by the Secretary of State or, for ships listed in paragraph (5), by the Assigning Authority. This information shall be amended whenever any alterations are made to the ship or changes occur to it which will materially affect this information and, if necessary, the ship shall be re-inclined.

- (4) The inclining test may be dispensed with if—
- (a) in the case of any ship basic stability data is available from the inclining test of a sister ship and it is known that reliable stability information can be obtained from such data; and
 - (b) in the case of
 - (i) a ship specially designed for the carriage of liquids or ore in bulk, or
 - (ii) of any class of such ships,
 the information available in respect of similar ships shows that the ship's proportions and arrangements will ensure more than sufficient stability in all probable loading conditions.
- (5) Before this information is issued to the master—
- (a) if it relates to a ship which is—
 - (i) an oil tanker over 100 metres in length;
 - (ii) a bulk carrier, or an ore carrier, over 150 metres in length;
 - (iii) a single deck bulk carrier over 100 metres in length but not exceeding 150 metres in length;
 - (iv) a single deck dry cargo ship over 100 metres in length;
 - (v) a purpose built container ship over 125 metres in length;
 - (vi) a column stabilised mobile offshore drilling unit; or
 - (vii) a column stabilised mobile offshore support unit,
 it shall be approved either by the Secretary of State or the Assigning Authority which assigned freeboards to the ship; and
 - (b) if it relates to any other ship, it shall be approved by the Secretary of State.

Information as to loading and ballasting of ships

33.—(1) The owner of any ship of more than 150 metres in length specially designed for the carriage of liquids or ore in bulk shall provide, for the guidance of the master, information relating to the loading and ballasting of the ship.

(2) This information shall indicate the maximum stresses permissible for the ship and specify the manner in which the ship is to be loaded and ballasted to avoid the creation of unacceptable stresses in its structure.

(3) In the case of a United Kingdom ship the provisions of regulation 32(5) shall have effect in respect of information required under this regulation, and the information so approved shall be included in the book referred in regulation 32(1).

PART VII

EQUIVALENTS, PENALTIES AND DETENTION

Equivalents

- 34.** The Assigning Authority may, with the approval of the Secretary of State—
- (a) allow any fitting, material, appliance or apparatus to be fitted in a ship, or allow other provisions to be made in a ship, in the place of any fitting, material, appliance, apparatus or provision respectively which is required under any of the provisions of these Regulations, if satisfied by trial or otherwise that it is at least as effective as that so required; or

- (b) allow in an exceptional case departure from the requirements of any of the said provisions on condition that the freeboards to be assigned to the ship are increased to such an extent as to satisfy the Secretary of State that the safety of the ship and protection afforded to the crew will be no less effective than would be the case if the ship fully complied with those requirements and there were no such increase of freeboards.

Penalties

35.—(1) Where regulation 6(1) is contravened the owner and master of the ship shall each be guilty of an offence and liable:

- (a) on summary conviction, to a fine not exceeding the statutory maximum; and
- (b) on conviction on indictment, to a fine.

(2) Any contravention of regulation 6(3) shall be an offence by both the owner and master and, being an offence corresponding to the offence under paragraphs 4(2) and (3) and 14 of Schedule 3 to the Merchant Shipping Act 1995, shall be punishable:

- (a) on summary conviction, by a fine not exceeding the statutory maximum and by such additional fine, not exceeding an amount calculated in accordance with paragraph (3), as the court thinks fit to impose, having regard to the extent to which the earning capacity of the ship was increased by reason of the contravention; and
- (b) on conviction on indictment, by a fine.

(3) Any additional fine imposed under paragraph (2)(a) shall not exceed £1,000 for each complete centimetre by which—

- (a) in a case falling within regulation 6(3)(a), the appropriate load line on each side of the ship was submerged; or
- (b) in a case falling within regulation 6(3)(b), the appropriate load line on each side of the ship would have been submerged.

(4) Any contravention of regulation 6(4) shall be an offence by the master and by any other person who, having reason to believe that the ship is so loaded, sends or is party to sending the ship to sea, punishable (without prejudice to any fine liable in respect of an offence under paragraph (2)):

- (a) on summary conviction, by a fine not exceeding the statutory maximum; and
- (b) on conviction on indictment, by a fine.

(5) Where a person is charged with an offence under paragraph (2), it shall be a defence to prove that the contravention was due solely to deviation or delay and that the deviation or delay was caused solely by stress of weather or other circumstances which neither the master nor the owner nor the charterer (if any) could have prevented or forestalled.

- (a) (6) (a) Any contravention of regulation 23(1) shall be an offence by both the owner and the master punishable on summary conviction by a fine not exceeding level 5 on the standard scale.
- (b) Any contravention of regulation 23(2) by any person shall be an offence punishable on summary conviction by a fine not exceeding level 5 on the standard scale.
- (c) It shall be a defence for a person charged under this paragraph to show he had reasonable excuse for the contravention.

(7) Any contravention of regulation 9(4) shall be an offence by the master punishable—

- (a) on summary conviction, by a fine not exceeding the statutory maximum; and
- (b) on conviction on indictment, by a fine.

(8) Any contravention of regulation 13 shall be an offence by both the master and owner punishable on summary conviction by a fine not exceeding level 3 on the standard scale.

Offences and penalties in relation to certificates and surveys

36.—(1) No person shall:

- (a) intentionally alter a certificate referred to in these Regulations;
- (b) falsely make a certificate referred to in these Regulations;
- (c) in connection with any survey required by these Regulations, knowingly or recklessly furnish false information;
- (d) with intent to deceive, use, lend, or allow to be used by another, a certificate referred to in these Regulations;
- (e) fail to surrender a certificate required to be surrendered under regulation 11; or
- (f) in Scotland forge any certificate referred to in these Regulations.

(2) Any contravention of paragraph (1) shall be an offence punishable on summary conviction by a fine not exceeding the statutory maximum, or on conviction on indictment by imprisonment for a term not exceeding 6 months, or a fine, or both.

Detention

37.—(1) Any ship which, in contravention of regulation 6(1), proceeds or attempts to proceed to sea without being surveyed and marked may be detained until it has been so surveyed and marked.

(2) Any ship which does not comply with the conditions of assignment applicable to it shall be liable to be detained until it complies.

(3) Without prejudice to any proceedings under regulation 33, any ship which is loaded in contravention of regulation 6(3) may be detained until it ceases to be so loaded.

(4) In any case where a ship is liable to be detained section 284 of the Merchant Shipping Act 1995⁽¹⁹⁾ (which relates to the detention of a ship) shall have effect in relation to the ship, subject to the modification that as if for the words “this Act” wherever they appear, there were substituted the words “the Merchant Shipping (Load Lines) Regulations 1998”.

(5) The provisions of sections 96 and 97 (except section 96(3) and the words “as a dangerously unsafe ship” in section 96(5) of the Merchant Shipping Act 1995 shall apply in relation to a detention notice issued pursuant to this regulation as they apply in relation to detention notices issued pursuant to section 95, and in such application “the relevant inspector” means a person issuing the detention notice.

Signed by the authority of the Secretary of State for the Environment, Transport and the Regions

Glenda Jackson
Parliamentary Under Secretary of State,
Department of the Environment, Transport and
the Regions

8th September 1998

(19) Section 284 was amended by the Merchant Shipping and Maritime Security Act 1997, Schedule 1.

EXPLANATORY NOTE

(This note is not part of the Regulations)

1. These Regulations replace section 89 and Schedule 3 of the Merchant Shipping Act 1995, the Merchant Shipping (Load Line) Rules 1968 and amendments and other instruments made for the purpose of defining and elaborating Schedule 3, without substantive change.
2. The Regulations apply the provisions of the International Convention on Load Lines, 1966 to all United Kingdom ships which go to sea, with certain exceptions. They also apply to all sea-going foreign ships within United Kingdom waters.
3. A number of the detailed technical requirements and specifications are now contained in a Merchant Shipping Notice, MSN 1701(M).
4. The Regulations enable the Secretary of State to authorise persons or organisations to act as Assigning Authorities for the purpose of the Regulations. Currently so authorised are Lloyd's Register of Shipping, the British Committee of Bureau Veritas, the British Committee of Det Norske Veritas, the British Committee of Germanischer Lloyd, the British Committee of Registro Italiano Navale and the British Technical Committee of the American Bureau of Shipping.
5. Merchant Shipping Notices are obtainable from Eros Marketing Support Services Ltd, Delta House, Imber Court Business Park, Orchard Lane, East Moseley, Surrey. International Maritime Organisation Resolutions are obtainable from IMO, 4 Albert Embankment, London SE1 7SR.