

2004 No. 317

SEEDS

The Oil and Fibre Plant Seed (Scotland) Regulations 2004

Made - - - - - *1st July 2004*

Laid before the Scottish Parliament *2nd July 2004*

Coming into force - - - *26th September 2004*

ARRANGEMENT OF REGULATIONS

**PART I
GENERAL**

1. Citation, commencement and extent
2. Interpretation
3. Definitions of seed categories
4. Definition of marketing
5. Seed to which the Regulations apply

**PART II
MARKETING**

6. Marketing of seed
7. Mixtures
8. Exception for scientific selection work and for tests and trials
9. Varietal associations
10. General exemptions
11. Marketing of officially certified lower germination seed
12. Marketing of early movement seed
13. Requirement for homogeneity

**PART III
PROCEDURES FOR ISSUING OFFICIAL CERTIFICATES**

14. Applications for official certificates
15. Sampling

**PART IV
PACKAGING AND LABELLING REQUIREMENTS FOR FULLY CERTIFIED SEED**

16. Sealing of packages of fully certified seed
17. Labelling of packages of fully certified seed
18. Marketing of unpacked seed

**PART V
PROCEDURES FOR ISSUING BREEDER'S CONFIRMATIONS**

19. Breeder's confirmations

**PART VI
PACKAGING AND LABELLING REQUIREMENTS RELATING TO BREEDER'S
CONFIRMATION**

20. Sealing of packages of seed in relation to breeder's confirmation
21. Labelling of packages of seed in relation to breeder's confirmation

**PART VII
MISCELLANEOUS**

22. Comparative tests and trials
23. Civil liabilities of sellers of seed
24. Service of notices
25. Written and electronic communication
26. Amendment to the Seeds (Fees) (Scotland) Regulations 2002
27. Revocations and transitional provisions

**SCHEDULE 1
SPECIES OF SEED TO WHICH THE REGULATIONS APPLY**

**SCHEDULE 2
OFFICIAL CERTIFICATES AND BREEDER'S CONFIRMATIONS**

**PART I
OFFICIAL CERTIFICATES**

1. Applications for seed harvested in the United Kingdom
2. When applications will be refused
3. When applications may be refused
4. Applications for seed harvested in an EEA State or third country

**PART II
BREEDER'S CONFIRMATIONS**

5. Applications
6. When applications will be refused
7. When applications may be refused

**SCHEDULE 3
PARTICULARS TO BE SPECIFIED IN AN OFFICIAL CERTIFICATE OR A
BREEDER'S CONFIRMATION**

1. Particulars to be specified in an official certificate
2. Particulars to be specified in a breeder's confirmation

SCHEDULE 4

REQUIREMENTS FOR BASIC SEED, CERTIFIED SEED, CERTIFIED SEED OF THE FIRST GENERATION, CERTIFIED SEED OF THE SECOND GENERATION, CERTIFIED SEED OF THE THIRD GENERATION AND COMMERCIAL SEED

PART I

CONDITIONS RELATING TO CROPS FROM WHICH SEED OTHER THAN COMMERCIAL SEED IS OBTAINED

1. Methods of crop testing
2. Varietal identity and varietal purity
3. Crop inspection
4. Harmful organisms in the crop
5. Previous cropping
6. Isolation distances - general
7. Isolation distances - minimum distance
8. Standards for varietal purity
9. Crop conditions for Pre-basic Seed

PART II

CONDITIONS RELATING TO BASIC SEED, CERTIFIED SEED, CERTIFIED SEED OF THE FIRST GENERATION, CERTIFIED SEED OF THE SECOND GENERATION, CERTIFIED SEED OF THE THIRD GENERATION AND COMMERCIAL SEED

10. Standards for varietal purity
11. Standards for varietal purity for hybrid varieties of swede rape
12. Parental ratio in production of Certified Seed of hybrids of sunflower
13. Further standards and conditions of varietal purity
14. Further provisions relating to varietal purity
15. Harmful organisms in the seed

PART III

OFFICIAL EXAMINATIONS USED TO ASCERTAIN WHETHER A CROP OR SEED LOT MEETS THE CONDITIONS RELATING TO BASIC SEED, CERTIFIED SEED, CERTIFIED SEED OF THE FIRST GENERATION, CERTIFIED SEED OF THE SECOND GENERATION, CERTIFIED SEED OF THE THIRD GENERATION AND COMMERCIAL SEED

16. Methods for official examinations

SCHEDULE 5

PART I

SAMPLING OF SEED LOTS

1. Definitions
2. Obtaining a submitted sample
3. Primary sample size
4. Condition of the seed lot
5. Seed lot containers
6. Sampling from sacks - minimum number of containers to be sampled
7. Sampling from sacks or similar containers
8. Sampling from small containers - general
9. Sampling from small containers - moisture-proof containers
10. Sampling from small containers - primary samples
11. Sampling from large containers
12. Sampling from a seed stream

13. Sampling instruments - general
14. Sampling instruments - instruments and methods
15. Sampling instruments - power to allow other instruments and methods
16. Sampling instruments - instruments for drawing primary samples
17. Methods of use of dynamic spear samplers, stick samplers, cargo samplers and seed stream samplers - general
18. Methods of use of dynamic spear samplers, stick samplers, cargo samplers and seed stream samplers - specific
19. Obtaining a submitted sample - composite sample division instruments
20. Method of use of riffle divider
21. Methods of use of a centrifugal divider

PART II

MAXIMUM WEIGHT OF A SEED LOT AND MINIMUM WEIGHT OF A SUBMITTED SAMPLE

22. Maximum weight of a seed lot
23. Margin by which seed lots can exceed maximum weight
24. Minimum weight of a sample

SCHEDULE 6

PART I GENERAL

1. Method of referring to species of seed
2. Method of referring to varieties of seed

PART II LABELS

3. Label for a package of Breeder's Seed
4. Official label for a package of Pre-basic Seed
5. Official label for a package of Basic Seed or Seed of a Certified Generation
6. Official label for a package of Commercial Seed
7. Official label for a package of a varietal association of seed

PART III SMALL PACKAGES

8. Label for a small package of Pre-basic Seed, Basic Seed, Seed of a Certified Generation or Commercial Seed

PART IV

PARTICULARS TO BE MARKED OR DISPLAYED ON THE SALE OF UNPACKETED SEED

9. Particulars to be marked or displayed on the sale of unpacketed seed

PART V

INFORMATION IN RESPECT OF SEED IMPORTED FROM COUNTRIES WHICH ARE NOT EEA STATES IN PACKAGES EXCEEDING 2 KILOGRAMS NET WEIGHT

10. Information to be supplied in respect of seed imported from a country which is not an EEA State in a package exceeding 2 kilograms net weight

PART VI

PRINTING OF SPECIFIED MATTERS ON PACKAGES

(WHOLE BAG LABELLING)

11. Packages sealed in Scotland - printers' returns
12. Packages sealed in Scotland - individual serial numbers
13. Packages sealed in Scotland - printing or stamping
14. Packages sealed in Scotland - particulars to be included in the printing or stamp
15. Packages sealed in Scotland - lower germination seed
16. Packages sealed in Scotland - record keeping for lower germination seed
17. Seed packages sealed in the United Kingdom but not in Scotland, or in an EEA State other than the United Kingdom

SCHEDULE 7

LIMITS OF VARIATION

GERMINATION

ANALYTICAL PURITY

CONTENT OF SEEDS OF OTHER SPECIES

NUMBER OF SEEDS OF OTHER SPECIES

SCHEDULE 8

REVOCATIONS

The Scottish Ministers, in exercise of the powers conferred by sections 16(1), (1A), (2), (3), (4) and (5) and 36 of the Plant Varieties and Seeds Act 1964^(a) and of all other powers enabling them in that behalf, after consultation in accordance with section 16(1) of that Act with representatives of such interests as appear to them to be concerned, hereby make the following Regulations:

PART I

GENERAL

Citation, commencement and extent

1.—(1) These Regulations may be cited as the Oil and Fibre Plant Seed (Scotland) Regulations 2004, and shall come into force on 26th September 2004.

(2) These Regulations extend to Scotland only.

Interpretation

2.—(1) In these Regulations—

“the Act” means the Plant Varieties and Seeds Act 1964;

“Annex V(C) document” means a document of the type specified in the second indented sub-paragraph of the first paragraph of Article 19(2) (packing and labelling of not yet finally certified seed harvested in another EEA State or third country) of the Oil and Fibre Plant Seed Directive containing the particulars specified in Part C (document to be provided in the case of not yet finally certified seed harvested in another EEA State or third country) of Annex V of that Directive issued by the relevant competent seed certification authority;

^(a) 1964 c.14; section 16 was amended by the European Communities Act 1972 (c.68), section 4(1) and Schedule 4, paragraph 5(1) and (2). See section 38(1) for the definition of “the Minister”. The functions of the Secretary of State were transferred to the Scottish Ministers by virtue of section 53 of the Scotland Act 1998 (c.46).

“black mustard” means plants of the species specified in column 2 of Schedule 1 in relation to black mustard;

“blended seed lot” means a seed lot obtained by mixing seed where–

- (a) the seed that goes into the seed lot–
 - (i) is of the same variety;
 - (ii) has come from different sources; and
 - (iii) either–
 - (aa) is fully certified seed;
 - (bb) is not fully certified seed, but is seed which has been harvested from seed crops for which official field inspection reports have been issued showing that the relevant crops met the conditions for the relevant category of seed specified in Part I of Schedule 4 or Annex I (crop conditions) of the Oil and Fibre Plant Seed Directive; or
 - (cc) is made up of seed which falls within sub-paragraph (aa) and seed which falls within sub-paragraph (bb); and
- (b) a National Authority has been notified that the seed which goes into the seed lot is intended to be included in a blended seed lot;

“breeder”–

- (a) in relation to a variety which has not been accepted on to a UK National List or the Common Catalogue, includes any person lawfully multiplying (on their own account) seed bred by another; and
- (b) in relation to a variety which has been so accepted, means the person who is indicated in the relevant UK National List or in the Common Catalogue as responsible for maintaining the plant variety in accordance with the characteristics to which regard was had when the plant variety was accepted on to the relevant UK National List or Common Catalogue;

“breeder’s confirmation” means a document issued by the Scottish Ministers in accordance with Part II of Schedule 2 containing in respect of the seed to which it relates the particulars specified in paragraph 2 of Schedule 3;

“brown mustard” means plants of the species specified in column 2 of Schedule 1 in relation to brown mustard;

“bulked seed lot” means a seed lot obtained by mixing seed where–

- (a) the seed that goes into the seed lot is–
 - (i) of the same variety;
 - (ii) has come from different sources; and
 - (iii) has been harvested from seed crops for which official field inspection reports have been issued showing that the relevant crops met the conditions for the relevant category of seed specified in Part I of Schedule 4 or Annex I (crop conditions) of the Oil and Fibre Plant Seed Directive; and
- (b) a National Authority has been notified that the seed which goes into the seed lot is intended to be included in a bulked seed lot;

“Common Catalogue” means the Common Catalogue of varieties of species of agricultural plants published in the Official Journal of the European Communities;

“the Common Catalogue Directive” means Council Directive 2002/53/EC(a) on the common catalogue of varieties of agricultural plant species, as amended by the Food and Feed Regulation;

“component” means–

- (a) in the case of Pre-basic Seed, a component used in the production of a hybrid variety; and
- (b) in the case of Basic Seed, a component of a hybrid variety;

(a) O.J. No. L 193, 20.7.02, p.1.

“control plot” means a plot sown by a European Authority with seed from a submitted sample taken–

- (a) by a European Authority; or
- (b) by a licensed seed sampler;

“the 1990 Deliberate Release Directive” means Council Directive 90/220/EEC(a) on the deliberate release into the environment of genetically modified organisms, as amended by Commission Directive 94/15/EC(b) and Commission Directive 97/35/EC(c);

“the 2001 Deliberate Release Directive” means Directive 2001/18/EC of the European Parliament and of the Council(d) on the deliberate release into the environment of genetically modified organisms and repealing Council Directive 90/220/EEC, as amended by Commission Decision 2002/623(e), the Food and Feed Regulation and Regulation (EC) No 1830/2003 of the European Parliament and of the Council(f);

“Department of Agriculture and Rural Development” means the Department of Agriculture and Rural Development in Northern Ireland;

“dioecious hemp” means hemp of dioecious hemp varieties;

“early movement seed” means seed marketed under regulation 12;

“EEA State” means a Member State, Norway, Iceland or Lichtenstein;

“Equivalence Decision” means Council Decision 2003/17/EC(g) on the equivalence of field inspections carried out in third countries on seed-producing crops and on the equivalence of seed produced in third countries, as amended by Council Decision 2003/403/EC(h) and Council Regulation (EC) No 885/2004(i);

“European Authority” means a National Authority or a competent seed certification authority of an EEA State other than the United Kingdom and “by a European Authority” means–

- (a) by or on behalf of the Department of Agriculture and Rural Development;
- (b) by or on behalf of the National Assembly for Wales;
- (c) by the Scottish Ministers;
- (d) by or on behalf of the Secretary of State; or
- (e) by a competent seed certification authority of an EEA State other than the United Kingdom;

“first buyer by way of trade” has the same meaning as for the purposes of the Oil and Fibre Plant Seed Directive;

“flax” means plants of the species specified in column 2 of Schedule 1 in relation to flax, commonly known as flax;

“the Food and Feed Regulation” means Regulation (EC) No 1829/2003 of the European Parliament and of the Council(j) on genetically modified food and feed;

“fully certified” means–

- (a) officially certified; or
- (b) certified by a European Authority other than the Scottish Ministers,

as satisfying the conditions specified for the relevant category of seed in regulation 3 and in Annexes I (crop conditions) and II (seed conditions) of the Oil and Fibre Plant Seed Directive;

“genetically modified” has the same meaning as for the purposes of the 2001 Deliberate Release Directive;

“hemp” means plants of the species specified in column 2 of Schedule 1 in relation to hemp;

(a) O.J. No. L 117, 8.5.90, p.15.
(b) O.J. No. L 103, 22.4.94, p.20.
(c) O.J. No. L 169, 27.6.97, p.72.
(d) O.J. No. L 106, 17.4.01, p.1.
(e) O.J. No. L 200, 30.7.02, p.22.
(f) O.J. No. L 268, 18.10.03, p.24.
(g) O.J. No. L 8, 14.1.03, p.10.
(h) O.J. No. L 141, 7.6.03, p.23.
(i) O.J. No. L 168, 1.5.04, p.1.
(j) O.J. No. L 268, 18.10.03, p.1.

“homogeneous seed lot” means a seed lot in which the seed has been so mixed or blended that it is as uniform as practicable and, as far as is practicable, the seed lot shows no evidence of heterogeneity;

“inbred line” means a sufficiently uniform and stable line obtained either by artificial self-fertilisation with selection over several successive generations or by equivalent operations;

“licensed crop inspector” means a person who holds a current licence to be a crop inspector granted by–

- (a) the Scottish Ministers under regulation 10(1) (licensing of seed samplers and crop inspectors) of the Seeds (Registration, Licensing and Enforcement) Regulations 1985(a); or
- (b) a National Authority other than the Scottish Ministers under provisions equivalent to that regulation;

“licensed EC crop inspector” means a person authorised by a competent seed certification authority in an EEA State other than the United Kingdom, pursuant to Article 2(5)(a)(iii) (licensed crop inspectors) of the Oil and Fibre Plant Seed Directive, to carry out field inspections of crops in that EEA State;

“licensed seed sampler” means a person who holds a current licence to be a seed sampler granted by–

- (a) the Scottish Ministers under regulation 10(1) (licensing of seed samplers and crop inspectors and licensed seed samplers) of the Seeds (Registration, Licensing and Enforcement) Regulations 1985; or
- (b) a National Authority other than the Scottish Ministers under provisions equivalent to that regulation;

“licensed seed testing station” means an establishment which holds a current licence for testing of seed granted by–

- (a) the Scottish Ministers under regulation 9(1) (licensing of seed testing stations) of the Seeds (Registration, Licensing and Enforcement) Regulations 1985; or
- (b) a National Authority other than the Scottish Ministers under provisions equivalent to that regulation;

“linseed” means plants of the species specified in column 2 of Schedule 1 in relation to linseed, commonly known as linseed;

“lower germination seed” means seed marketed under regulation 11;

“monoecious hemp” means hemp of monoecious hemp varieties;

“National Authority” means the Department of Agriculture and Rural Development, the National Assembly for Wales, the Scottish Ministers or the Secretary of State;

“official certificate” means a certificate issued by the Scottish Ministers in accordance with Part I of Schedule 2 containing in respect of the seed to which it relates the particulars specified in paragraph 1 of Schedule 3 and “officially certified” shall be construed accordingly;

“official examination” means–

- (a) in relation to Seed of a Certified Generation or Commercial Seed–
 - (i) an examination or a test carried out by the Scottish Ministers;
 - (ii) if the seed has undergone official post-control the results of which have been satisfactory, a field examination carried out by a licensed crop inspector; or
 - (iii) a test carried out by a licensed seed testing station; and
- (b) in relation to Pre-basic Seed and Basic Seed–
 - (i) an examination or a test carried out by the Scottish Ministers; or
 - (ii) a test carried out by a licensed seed testing station;

“official field inspection” means a field examination of a crop carried out–

- (i) by a European Authority; or
- (ii) in the case of seed which, if it were fully certified would be Seed of a Certified Generation, or Commercial Seed, and which has been harvested from a crop which has been produced

(a) S.I. 1985/980, as relevantly amended by S.I. 1987/1098, 1990/611 and 1993/2530.

from seed that has undergone official post-control the results of which have been satisfactory, by a field examination of the crop carried out by a licensed crop inspector or a licensed EC crop inspector;

“official label” means a label issued by a European Authority;

“official post-control” means a control plot has been sown with seed from the relevant seed lot and has produced plants which have been examined by the relevant European Authority; and “official post-control the results of which have been satisfactory” means official post control has been carried out for the relevant seed lot and the relevant European Authority has found, having regard to—

(a) the conditions specified in—

(i) in the case of the Scottish Ministers—

(aa) paragraphs 4, 8 and 9 of Part I of Schedule 4;

(bb) paragraphs 10, 11 and 15(1) of Part II of Schedule 4; and

(ii) in the case of a European Authority other than the Scottish Ministers—

(aa) Annex I (crop conditions) of the Oil and Fibre Plant Seed Directive; and

(bb) Annex II (seed conditions) of the Oil and Fibre Plant Seed Directive; and

(b) the category of the seed to be produced,

that the plants produced in the control plot indicate that the corresponding plants in the field are satisfactory plants from which to harvest the relevant category of seed;

“Oil and Fibre Plant Seed Directive” means Council Directive 2002/57/EC on the marketing of seed of oil and fibre plants^(a) as amended by Council Directive 2002/68/EC^(b), Commission Directive 2003/45/EC^(c) and Council Directive 2003/61/EC^(d);

“Secretary of State” means the Secretary of State for Environment, Food and Rural Affairs;

“seed lot” means an identifiable consignment of seed of a weight not exceeding that specified in column 2 of the table in paragraph 24 of Part II of Schedule 5 for the species specified in column 1 of that table by more than 5%, including a blended seed lot and a bulked seed lot, which bears a unique seed lot reference number;

“small package” means a package containing a net weight of not more than 15 kilograms of fully certified Pre-basic Seed, fully certified Basic Seed, Seed of a Certified Generation or Commercial Seed;

“soya bean” means plants of the species specified in column 2 of Schedule 1 in relation to soya bean;

“submitted sample” means a sample of at least the minimum weight of a sample specified in paragraph 24 of Part II of Schedule 5, or in the case of a sample to be submitted to a licensed seed testing station, double the minimum weight of a sample specified in paragraph 24 of Part II of Schedule 5, taken from a seed lot in accordance with the provisions of Part I of Schedule 5;

“sunflower” means plants of the species specified in column 2 of Schedule 1 in relation to sunflower;

“swede rape” means plants of the species specified in column 2 of Schedule 1 in relation to swede rape, including plants commonly known as swede fodder rape and swede oilseed rape;

“third country” means a country listed in Annex I (countries, authorities and species) to the Equivalence Decision or Switzerland;

“turnip rape” means plants of the species specified in column 2 of Schedule 1 in relation to turnip rape, including plants commonly known as turnip fodder rape and turnip oilseed rape;

“UK National List ” means a list of varieties of species of oil and fibre plants for the time being published in accordance with the Seeds (National Lists of Varieties) Regulations 2001^(e);

(a) O.J. No. L 193, 20.7.02, p.74.
(b) O.J. No. L 195, 24.7.02, p.32.
(c) O.J. No. L 138, 5.6.03, p.40.
(d) O.J. No. L 165, 3.7.03, p.23.
(e) S.I. 2001/3510.

“white mustard” means plants of the species specified in column 2 of Schedule 1 in relation to white mustard.

(2) In these Regulations–

- (a) any reference to a numbered regulation, to a numbered Part or to a numbered Schedule is a reference to the regulation, Part or Schedule in these Regulations so numbered; and
- (b) any reference to a numbered paragraph is a reference to the paragraph so numbered in the regulation or Schedule in which that reference occurs.

Definitions of seed categories

3. In these Regulations–

“Breeder’s Seed” means seed of a generation prior to Basic Seed which has been produced by or under the responsibility of the breeder and is intended for the production of Pre-basic Seed or Basic Seed;

“Pre-basic Seed” means seed of a generation prior to Basic Seed which–

- (a) other than in relation to a component used in the production of a hybrid variety–
 - (i) has been produced by or under the responsibility of the breeder according to accepted practices for the maintenance of the variety; and
 - (ii) is intended to be used for the production of more Pre-basic Seed, Basic Seed, or with the written authority of the breeder–
 - (aa) in the case of black mustard, brown mustard, dioecious hemp, sunflower, swede rape, turnip rape or white mustard, Certified Seed;
 - (bb) in the case of flax, linseed, monoecious hemp or soya bean, Certified Seed of the First Generation;
 - (cc) in the case of flax, linseed, monoecious hemp or soya bean, Certified Seed of the Second Generation; or
 - (dd) in the case of flax or linseed, Certified Seed of the Third Generation; or
- (b) in relation to a component of a hybrid variety seed is intended to be used for the production of–
 - (i) more Pre-basic Seed of the component;
 - (ii) Basic Seed; or
 - (iii) with the written authority of the breeder, Certified Seed of a hybrid variety; and
- (c) has been–
 - (i) officially certified, or certified by the Scottish Ministers by means of a breeder’s confirmation, as satisfying the conditions specified in paragraph (a) or (b) and the requirements for Basic Seed specified in Schedule 4; or
 - (ii) certified by a European Authority other than the Scottish Ministers as satisfying the conditions specified in paragraph (a) or (b) and the requirements for Basic Seed specified in Annexes I (crop conditions) and II (seed conditions) of the Oil and Fibre Plant Seed Directive;

“Basic Seed” means seed which–

- (a) in relation to black mustard, brown mustard, flax, hemp, linseed, soya bean, sunflower, swede rape, turnip rape and white mustard, other than a hybrid variety–
 - (i) has been produced by or under the responsibility of the breeder according to accepted practices for the maintenance of the variety; and
 - (ii) is intended to be used for the production of–
 - (aa) in the case of black mustard, brown mustard, dioecious hemp, sunflower, swede rape, turnip rape or white mustard, Certified Seed;
 - (bb) in the case of flax, linseed, monoecious hemp or soya bean, Certified Seed of the First Generation;

- (cc) in the case of flax, linseed, monoecious hemp or soya bean, Certified Seed of the Second Generation; or
- (dd) in the case of flax or linseed, Certified Seed of the Third Generation; or
- (b) in relation to a component of a hybrid variety, or an inbred line which is a component of a hybrid variety, seed which is intended to be used for the production of Certified Seed of a hybrid variety; or
- (c) in relation to a simple hybrid which is a component of a hybrid variety, seed which is intended to be used for the production of Certified Seed of a double cross hybrid variety or three way cross hybrid variety, where–
 - (i) “single cross hybrid” means the first generation of a cross between two inbred lines, defined by the breeder;
 - (ii) “double cross hybrid” means the first generation of a cross between two single cross hybrids, defined by the breeder; and
 - (iii) “three way cross hybrid” means the first generation of a cross between an inbred line and a single cross hybrid, defined by the breeder; and
- (d) has been–
 - (i) officially certified, or certified by the Scottish Ministers by means of a breeder’s confirmation, as satisfying the conditions specified in paragraphs (a), (b) or (c) and the requirements for Basic Seed specified in Schedule 4; or
 - (ii) certified by a European Authority other than the Scottish Ministers as satisfying the conditions specified in paragraph (a), (b) or (c) and the requirements for Basic Seed specified in Annexes I (crop conditions) and II (seed conditions) of the Oil and Fibre Plant Seed Directive;

“Certified Seed” means seed which, in relation to black mustard, brown mustard, dioecious hemp, sunflower, swede rape, turnip rape and white mustard including hybrids–

- (a) has been produced directly from Basic Seed or, with the breeder’s written authority, from Pre-basic Seed;
- (b) is intended for purposes other than the production of oil and fibre plant seed; and
- (c) has been–
 - (i) officially certified as satisfying the conditions specified in paragraphs (a) and (b) and the requirements for Certified Seed specified in Schedule 4; or
 - (ii) certified by a European Authority other than the Scottish Ministers as satisfying the conditions specified in sub-paragraphs (a) and (b) and the requirements for Certified Seed specified in Annexes I (crop conditions) and II (seed conditions) of the Oil and Fibre Plant Seed Directive;

“Certified Seed of the First Generation” means seed of flax, linseed, monoecious hemp or soya bean which–

- (a) has been produced directly from Basic Seed or, with the written authority of the breeder, from Pre-basic Seed;
- (b) is intended–
 - (i) for the production of Certified Seed of the Second Generation;
 - (ii) in the case of flax or linseed for the production of Certified Seed of the Third Generation; or
 - (iii) for purposes other than the production of oil and fibre plant seed; and
- (c) has been
 - (i) officially certified as meeting the conditions specified in paragraphs (a) and (b) and the requirements for Certified Seed of the First Generation specified in Schedule 4; or
 - (ii) certified by a European Authority other than the Scottish Ministers as satisfying the conditions specified in paragraphs (a) and (b) and the requirements for Certified Seed of the

First Generation specified in Annexes I (crop conditions) and II (seed conditions) of the Oil and Fibre Plant Seed Directive;

“Certified Seed of the Second Generation” means seed of flax, linseed, monoecious hemp or soya bean which–

- (a) in the case of flax, linseed or soya bean–
 - (i) has been produced directly from the Basic Seed, Certified Seed of the First Generation or, with the written authority of the breeder, from Pre-basic Seed;
 - (ii) is intended–
 - (aa) in the case of flax or linseed, for the production of Certified Seed of the Third Generation; or
 - (bb) in the case of flax, linseed or soya bean for purposes other than the production of oil and fibre plant seed; and
 - (iii) has been–
 - (aa) officially certified as satisfying the conditions specified in sub-paragraphs (i) and (ii) and the requirements for Certified Seed of the Second Generation specified in Schedule 4; or
 - (bb) certified by a European Authority other than the Scottish Ministers as satisfying the conditions specified in sub-paragraphs (i) and (ii) and the requirements for Certified Seed of the Second Generation specified in Annexes I (crop conditions) and II (seed conditions) of the Oil and Fibre Plant Seed Directive;
- (b) in the case of monoecious hemp–
 - (i) has been produced directly from Certified Seed of the First Generation which has been established and officially controlled with a special view to the production of Certified Seed of the Second Generation;
 - (ii) is intended for the production of hemp to be harvested in flower; and
 - (iii) has been–
 - (aa) officially certified as satisfying the conditions specified in sub-paragraphs (i) and (ii) and the requirements of Certified Seed of the Second Generation specified in Schedule 4; or
 - (bb) certified by a European Authority other than the Scottish Ministers as satisfying the conditions specified in sub-paragraphs (i) and (ii) and the requirements for Certified Seed of the Second Generation specified in Annexes I (crop conditions) and II (seed conditions) of the Oil and Fibre Plant Seed Directive;

“Certified Seed of the Third Generation“ means seed of flax or linseed which–

- (a) has been produced directly from Basic Seed, Certified Seed of the First Generation or Certified Seed of the Second Generation or, with the written authority of the breeder, from Pre-basic Seed;
- (b) is intended for purposes other than the production of oil and fibre plant seed; and
- (c) has been–
 - (i) officially certified as satisfying the conditions specified in paragraphs (a) and (b) and the requirements for Certified Seed of the Third Generation specified in Schedule 4; or
 - (ii) certified by a European Authority other than the Scottish Ministers as satisfying the conditions specified in paragraphs (a) and (b) and the requirements for Certified Seed of the Third Generation specified in Annexes I (crop conditions) and II (seed conditions) of the Oil and Fibre Plant Seed Directive;

“Commercial Seed” means seed of black mustard which–

- (a) is identifiable as to its species; and
- (b) has been–
 - (i) officially certified as satisfying the conditions specified in paragraph (a) and the requirements for Certified Seed specified in Part II of Schedule 4; or

- (ii) certified by a European Authority other than the Scottish Ministers as satisfying the conditions specified in paragraph (a) and the requirements for Certified Seed specified in Annex II (seed conditions) of the Oil and Fibre Plant Seed Directive;

“Seed of a Certified Generation” means Certified Seed, Certified Seed of the First Generation, Certified Seed of the Second Generation and Certified Seed of the Third Generation.

Definition of marketing

4.—(1) In these Regulations “marketing” means—

- (a) selling, holding with a view to sale and offering for sale; and
- (b) any disposal, supply or transfer for the purpose of commercial exploitation of seed to third parties,

whether or not for consideration, and “market” and “marketed” shall be construed accordingly.

(2) Trade in seed not aimed at commercial exploitation of the variety, such as the following operations:—

- (a) the supply of seed to official testing and inspection bodies; or
- (b) the supply of seed to any person for the purposes of processing or packaging the seed provided that person does not acquire title to the seed supplied,

shall not be treated as marketing of seed of that variety.

Seed to which the Regulations apply

5.—(1) Subject to paragraph (2), these Regulations apply to oil and fibre plant seed of the species specified in Schedule 1, being seed intended to be used only for the production of agricultural crops other than for ornamental purposes.

(2) These Regulations shall not apply to seed which is shown to be intended for export to a country which is not an EEA State.

PART II MARKETING

Marketing of seed

6.—(1) Subject to the provisions of this Part, no person shall market any seed unless—

- (a) it is marketed in seed lots or in parts of seed lots; and
- (b) it is—
 - (i) Commercial Seed; or
 - (ii) seed of a plant variety of a species specified in Part I of Schedule 1 (varieties of plant species on national lists) to the Seeds (National Lists of Varieties) Regulations 2001^(a) accepted on to a UK National List or the Common Catalogue and which is fully certified Pre-basic Seed, fully certified Basic Seed or Seed of a Certified Generation; or
 - (iii) Breeder’s Seed.

(2) Paragraph (1) shall not apply to the marketing of seed which has not yet been fully certified if—

- (a) the seed is marketed for processing;
- (b) the identity of the seed is ensured; and
- (c) the seed has been harvested from a crop which has been found by an official field inspection to satisfy the conditions specified in Part I of Schedule 4 or Annex I (crop conditions) of the Oil and Fibre Plant Seed Directive for the relevant category of seed.

^(a) S.I. 2001/3510.

(3) Where seed is sampled in an untreated state for either the official examination referred to in paragraph 2(c) of Part I of Schedule 2, or for an examination or test carried out by a European Authority other than the Scottish Ministers, and the seed is subsequently subjected to chemical treatment the seller shall, upon or before delivering the seed to the purchaser, provide the purchaser with a statement in writing that the seed has been subsequently subjected to chemical treatment and specifying the chemical nature of such treatment.

(4) Notwithstanding paragraph (1), no person shall market seed of a genetically modified variety unless it is clearly indicated, in the sales catalogue of the person marketing the seed and in any other marketing information or marketing representations provided by that person, as having been genetically modified.

(5) Any person marketing seed which has been imported from a country which is not an EEA State and which exceeds 2 kilograms of seed shall supply the Scottish Ministers, in such manner and at such time as the Scottish Ministers may require, with the particulars relating to the seed specified in paragraph 10 of Part V of Schedule 6.

Mixtures

7. Regulation 6(1) shall not prevent the marketing of a mixture of seed permitted by the Fodder Plant Seeds Regulations 1993(a) which includes seed of a species to which these Regulations apply which—

- (a) fell within regulation 6(1)(b)(i) or (ii); and
- (b) complied with the provisions of these Regulations,

before mixing with the fodder plant seed.

Exception for scientific selection work and for tests and trials

8.—(1) Regulation 6(1)(b) shall not apply to the marketing by a producer of—

- (a) small quantities of seed for scientific purposes or selection work; or
- (b) seed for test and trial purposes,

for which—

- (i) an authorisation has been granted to the producer by the Scottish Ministers in accordance with this regulation; or
- (ii) an authorisation has been granted to the producer by a European Authority other than the Scottish Ministers in respect of small quantities of seed for scientific purposes or selection work pursuant to Article 6(1)(a) (exemption for small quantities of seed for scientific purposes or selection work) of the Oil and Fibre Plant Seed Directive or in respect of seed for test and trial purposes, pursuant to Article 6(1)(b) (exemption for test and trial purposes) of the Oil and Fibre Plant Seed Directive.

(2) A producer in Scotland may apply to the Scottish Ministers for authorisation under this regulation.

(3) An application under this regulation shall be made in such form and manner and at such time as the Scottish Ministers shall require and shall be accompanied by such information as the Scottish Ministers may require for the purpose of determining whether to grant an authorisation.

(4) The Scottish Ministers shall not grant an authorisation under this regulation for scientific purposes and selection work in respect of seed of a genetically modified variety unless an authorisation is in force in respect of the variety concerned under the Food and Feed Regulation, or under Part B (deliberate release of GMOs for any other purpose than for placing on the market) or Part C (placing on the market of GMOs as or in products) of the 2001 Deliberate Release Directive, or under Part B (deliberate release of GMOs for any other purpose than for placing on the market) or Part C (placing on the market of GMOs as or in products) of the 1990 Deliberate Release Directive and then only if all appropriate measures, in accordance with the environmental risk assessment in respect of the genetically modified material carried out in accordance with Article 7(4) (environmental risk assessment for seed varieties) of the Common Catalogue

(a) S.I. 1993/2009, as relevantly amended by S.I. 1993/2529, 1996/1453, 1997/616, 1999/1864, S.S.I. 2000/247, S.I. 2001/3510 and S.S.I. 2002/564..

Directive have been taken by the producer of the seed to avoid adverse effects on human health and the environment.

(5) The Scottish Ministers shall not grant an authorisation under this regulation in respect of seed for test and trial purposes unless—

- (a) they consider that the amount of seed that may be marketed under it is of an appropriate quantity for the test or trial; and
- (b) (i) either—
 - (aa) an application has been submitted to the relevant authority under regulation 4(1)(a) (applications in relation to national lists) of the Seeds (National Lists of Varieties) Regulations 2001^(a) for acceptance of the variety concerned on to a UK National List and the application has not been withdrawn or finally determined; and
 - (bb) in the case of seed of a genetically modified variety, an authorisation is in force in respect of the variety concerned under the Food and Feed Regulation or under Part C (placing on the market of GMOs as or in products) of the 2001 Deliberate Release Directive or under Part C (placing on the market of GMOs as or in products) of the 1990 Deliberate Release Directive; or
- (ii) in the case of seed of a genetically modified variety, an authorisation is in force in respect of the variety concerned under Part B (deliberate release of GMOs for any other purpose than for placing on the market) of the 2001 Deliberate Release Directive or under Part B (deliberate release of GMOs for any other purpose than for placing on the market) of the 1990 Deliberate Release Directive.

(6) An authorisation under this regulation may—

- (a) and in the case of an authorisation in respect of seed for test and trial purposes shall, specify the amount of seed which may be marketed under it; and
- (b) impose such conditions as the Scottish Ministers may think necessary or desirable having regard to the nature of the scientific purpose or selection work involved in the case of an authorisation granted for scientific purposes and selection work and, in all cases, to the nature of the seed to which the authorisation relates, including a condition relating to the keeping of records in respect of the marketing of the seed.

Varietal associations

9.—(1) Regulation 6(1)(b) shall not apply to the marketing of a varietal association of seed—

- (a) to which these Regulations apply; and
- (b) the female and male components of which—
 - (i) have been dressed using a different coloured dressing; and
 - (ii) have been mechanically combined in proportions notified to a European Authority by the person responsible for the maintenance of the pollinator-dependent hybrid and pollinator within the varietal association.

(2) Subject to paragraph (3), the person responsible for the maintenance of the pollinator-dependent hybrid and pollinator within a varietal association may notify the Scottish Ministers of the proportions of the pollinator-dependent hybrid and pollinator within the varietal association.

(3) In a case where different persons are responsible for the maintenance of the pollinator-dependent hybrid and pollinator within a varietal association, those persons may notify the Scottish Ministers of the proportions of the pollinator-dependent hybrid and pollinator agreed by them within the varietal association.

(4) A notification given under paragraph (2) or (3) shall be made in such form and manner as the Scottish Ministers may require and be accompanied by such information and other documents as the Scottish Ministers may require.

^(a) S.I. 2001/3510.

(5) The Scottish Ministers shall acknowledge the receipt of each notification that they receive under paragraph (2) or (3).

(6) In this regulation—

“pollinator-dependent hybrid” means a male-sterile component within a varietal association (female component);

“pollinator” means a component shedding pollen within a varietal association (male component); and

“varietal association” means an association of Certified Seed of a specified pollinator-dependent hybrid accepted on to a UK National List or the Common Catalogue with Certified Seed of one or more specified pollinators similarly accepted.

General exemptions

10.—(1) Subject to paragraphs (2) and (3), the Scottish Ministers may, by a general licence, exempt any person or class of persons, or persons generally, from compliance with any provision of these Regulations.

(2) The Scottish Ministers shall not exercise the power to issue a general licence under paragraph (1) except—

(a) to the extent that the provisions of the general licence are permitted in accordance with a temporary experiment organised under Article 16 (temporary experiments) of the Oil and Fibre Plant Seed Directive;

(b) to the extent that the provisions of the general licence are permitted in accordance with Article 19(2) (waiving packing and labelling requirements for not yet fully certified seed imported from other EEA States) of the Oil and Fibre Plant Seed Directive;

(c) to give effect to the provisions of a Council Decision made under Article 20 (checks on third country field inspections and quality control) of the Oil and Fibre Plant Seed Directive, including for the avoidance of doubt the Equivalence Decision, and amendments made to such a Decision; or

(d) to the extent that the provisions of the general licence are permitted in accordance with measures taken pursuant to Article 21 (permission to market lower quality seed) of the Oil and Fibre Plant Seed Directive.

(3) A general licence issued under paragraph (1)—

(a) shall have effect during the period specified in it unless the Scottish Ministers revoke it earlier; and

(b) may impose such conditions as the Scottish Ministers may think necessary or desirable having regard to the marketing permitted by the general licence and the nature of the seed to which it relates, including a condition relating to the keeping of records in respect of the marketing of the seed.

Marketing of officially certified lower germination seed

11.—(1) Notwithstanding regulation 6(1)(b) and the requirement in regulation 3 that Pre-basic Seed and Basic Seed shall attain the minimum standards of germination specified for Basic Seed in Part II of Schedule 4 or Annex II (seed conditions) of the Oil and Fibre Plant Seed Directive, any person may, subject to paragraphs (2) and (3) and regulation 17(6) and the other provisions of these Regulations, market seed—

(a) in respect of which an official certificate certifying that the seed is of the relevant category of seed has been issued in accordance with Part I of Schedule 2, although it attains a lower percentage of germination than that specified in paragraph 13 of Part II of Schedule 4 in relation to Basic Seed by virtue of exception (ii) of paragraph 2 of Part I of Schedule 2;

(b) which has been certified as satisfying the conditions for the relevant category of seed by a European Authority other than the Scottish Ministers although the seed attains a lower germination than that specified in Annex II (seed conditions) of the Oil and Fibre Plant Seed Directive in relation to Basic Seed, by virtue of Article 5(a) (marketing of lower germination seed) of the Oil and Fibre Plant Seed Directive; or

- (c) which the person marketing the seed knows does not satisfy the minimum standards of germination specified for Basic Seed—
 - (i) in the case of seed which has been officially certified as being Pre-basic Seed or Basic Seed, in paragraph 13 of Part II of Schedule 4, irrespective of the findings of the Scottish Ministers; and
 - (ii) in the case of seed which has been fully certified as being Pre-basic Seed or Basic Seed by a European Authority other than the Scottish Ministers, in Annex II (seed conditions) of the Oil and Fibre Plant Seed Directive, irrespective of the findings of the relevant European Authority.

(2) Paragraph (1) shall not apply unless the person marketing the seed guarantees a specific minimum percentage of germination of the seed.

(3) Paragraph (1) shall not apply to seed which has been imported into the United Kingdom from a country which is not an EEA State.

Marketing of early movement seed

12.—(1) In a case where—

- (a) the official examination in respect of the germination of any seed lot of seed of a plant variety of a species specified in Part I (varieties of plant species on national lists) of Schedule 1 to the Seeds (National Lists of Varieties) Regulations 2001 accepted on to a UK National List or the Common Catalogue has not been completed, but a provisional germination report has shown that the seed attains the appropriate minimum standard of germination specified in paragraph 13 of Part II of Schedule 4 and the seed in all other respects satisfies the appropriate requirements of Schedule 4; or
- (b) any seed lot has been certified by a European Authority other than the Scottish Ministers by virtue of Article 5(b) (early movement of seed) of the Oil and Fibre Plant Seed Directive,

the seed lot or any part of the seed lot may, notwithstanding regulation 6(1)(b) but subject to paragraphs (2) to (5), regulation 17(7) and the other provisions of these Regulations, be marketed to the first buyer by way of trade.

(2) In the event of any marketing under paragraph (1), the seller of the seed shall—

- (a) upon or before delivery, provide the first buyer by way of trade with a written statement that the seed is marketed before the completion of the official germination test together with the result in the provisional germination report;
- (b) notify the Scottish Ministers in writing of the name and address of the first buyer by way of trade as soon as practicable after delivery and in any event not later than seven days after delivery;
- (c) guarantee a specific minimum percentage of germination, which shall be the percentage of the germination of the seed as ascertained in the provisional germination report; and
- (d) in the event of the official germination test showing the failure of the seed to comply with the minimum germination standard specified in paragraph 13 of Part II of Schedule 4 for seed of the relevant category, the seller shall provide the first buyer by way of trade with the result of the completed official germination test, in writing, as soon as practicable and in any event not later than seven days after being informed of it.

(3) The provisions of paragraph (1) shall not apply to the marketing of any seed lot or part of any seed lot in respect of which a previous official examination or an examination by a European Authority other than the Scottish Ministers has shown that the seed fails to meet the standards specified for the relevant category of seed in Part II of Schedule 4 or Annex II (seed conditions) of the Oil and Fibre Plant Seed Directive.

(4) A person who sells any seed in accordance with paragraph (1) shall make and, until the end of the period of two years after the date of delivery of the seed to the first buyer by way of trade, keep available for inspection by the Scottish Ministers a record of the date of such delivery, of the reference number of the seed lot or part of a seed lot delivered, of the name and address of the first buyer by way of trade, of the date on which the preliminary test of germination was carried out and of the result of that test in the

provisional germination report and, if appropriate, of the date on which the first buyer by way of trade was informed of the result of the completed official germination test.

(5) Paragraph (1) shall not apply to seed which has been imported into the United Kingdom from a country which is not an EEA State.

Requirement for homogeneity

13. No person shall market seed in accordance with regulation 6(1)(b)(i) or (ii), 11 or 12 unless it is marketed in a homogeneous seed lot or in part of a homogeneous seed lot.

PART III

PROCEDURES FOR ISSUING OFFICIAL CERTIFICATES

Applications for official certificates

14.—(1) An application in respect of a seed lot for the issue of an official certificate certifying the seed to be Pre-basic Seed, Basic Seed, Seed of a Certified Generation or Commercial Seed—

- (a) shall be made in writing to the Scottish Ministers in such form and manner, and shall include such information, records, illustrations, material and seed as the Scottish Ministers may require; and
- (b) shall be made not later than 31st December in the year following the year of harvest of the crop from which the seed lot is obtained or within such other time as the Scottish Ministers may allow.

(2) Where an application for the issue of an official certificate is made to the Scottish Ministers in accordance with paragraph (1) the Scottish Ministers shall, subject to paragraph (3), deal with the application in accordance with the provisions of Part I of Schedule 2.

(3) Where a breeder applies to the Scottish Ministers for the issue of an official certificate in accordance with paragraph (1), in respect of a seed lot which already has a breeder's confirmation after the variety of the seed in that seed lot has been accepted on to a UK National List (or an equivalent list in another EEA State) or, if the seed in the seed lot is a component of a hybrid variety of oilseed rape, after the hybrid variety has been accepted on to a UK National List (or an equivalent list in another EEA State), the Scottish Ministers shall issue an official certificate in respect of that seed lot provided they are satisfied that—

- (a) the seed is the seed in respect of which the breeder's confirmation was issued;
- (b) the breeder's confirmation has not been withdrawn pursuant to regulation 19(3);
- (c) the provisions of regulation 20 have been complied with; and
- (d) there is no reason why the breeder's confirmation should be withdrawn pursuant to regulation 19(3).

(4) An official certificate which has been issued by the Scottish Ministers may be withdrawn by them in respect of either the whole of a seed lot or any part of a seed lot if—

- (a) the results of an official examination of the sample taken from the seed lot in respect of which the official certificate has been issued are deemed to be null and void in accordance with regulation 15(2);
- (b) on the basis of information received by them, the Scottish Ministers are satisfied that the crop from which the seed in the seed lot was harvested did not meet the conditions laid down in Part I of Schedule 4;
- (c) on the basis of information received by them, the Scottish Ministers are satisfied that the seed in the seed lot, or part of the seed lot—
 - (i) did not meet the conditions laid down in Part II of Schedule 4 at the time the seed was tested for seed certification purposes, which includes the purpose of issuing a breeder's confirmation; or

(ii) although it met the conditions in Part II of Schedule 4 at the time of such testing no longer meets them; or

(d) the licensed seed sampler who sampled the seed lot or the licensed crop inspector or licensed EC crop inspector who inspected the crop, did so in breach of any of the terms of the licensed seed sampler's, or licensed crop inspector's, or licensed EC crop inspector's, licence,

and any seed from which an official certificate has been so withdrawn shall be deemed not to have been officially certified.

(5) The Scottish Ministers may withdraw the official certificate in respect of a seed lot, or any part of a seed lot, by giving notice to—

(a) the person who made an application in respect of the seed lot under paragraph (1); or

(b) any person marketing, or who has marketed, any of the seed.

(6) Where, in accordance with paragraph (5), the official certificate in respect of a seed lot, or part of a seed lot, is withdrawn under paragraph (4), the Scottish Ministers may notify—

(a) the person who made an application under paragraph (1) in respect of the seed lot;

(b) any person marketing, or who has marketed, any of the seed; and

(c) any person who has purchased, or been supplied with, any of the seed,

that the official certificate in respect of the seed lot, or part of a seed lot, as the case may be, has been withdrawn.

(7) Where the official certificate in respect of a seed lot, or part of a seed lot, is withdrawn under paragraph (4), any seller of the seed shall, as soon as practicable and in any case not later than 7 days after being informed of it, notify the purchaser, in writing, that the official certificate has been withdrawn and that the seed is deemed not to have been officially certified.

Sampling

15.—(1) A sample of seed taken for the purposes of an official examination shall be taken—

(a) (i) by a European Authority; or

(ii) by a licensed seed sampler in accordance with the terms of the licensed seed sampler's licence;

(b) in accordance with the methods specified in Part I of Schedule 5; and

(c) from a homogeneous seed lot.

(2) If a sample from a seed lot submitted or taken for the purpose of an official examination—

(a) is found not to have been taken in accordance with paragraph (1);

(b) is taken from a seed lot which, subject to paragraph 23 of Part II of Schedule 5, does not comply with paragraph 22 of Part II of Schedule 5;

(c) is not a submitted sample; or

(d) is otherwise found not to have been taken in accordance with the seeds regulations,

no, or no further, official examination of that sample shall be made under these Regulations, and any findings or results obtained in the course of any official examination of that sample, or from inspecting plants grown in a plot which has been sown with seed from that sample, shall be deemed to be null and void and shall be disregarded.

(3) For the avoidance of doubt, the provisions of this regulation apply for the purposes of issuing a breeder's confirmation, as they do for the purposes of issuing an official certificate.

PART IV

PACKAGING AND LABELLING REQUIREMENTS FOR FULLY CERTIFIED SEED

Sealing of packages of fully certified seed

16.—(1) Subject to regulation 18, no person shall market in accordance with regulations 6(1), 9, 11 or 12 a package (other than a small package sealed in accordance with paragraph (4)) of Commercial Seed, Pre-basic Seed, Basic Seed, Seed of a Certified Generation, a varietal association to which regulation 9 applies, lower germination seed or early movement seed unless, subject to paragraph (2), it has been—

- (a) (i) not later than at the time of sampling; or
 - (ii) in the case of seed which is wholly or partly re-packaged, the original package has been not later than at the time of sampling,
sealed in Scotland by the Scottish Ministers or a licensed seed sampler with a sealing device in such a manner that when the package is opened the sealing device will be broken and cannot be re-used; or
- (b) sealed—
 - (i) in the United Kingdom but not in Scotland; or
 - (ii) in an EEA State other than the United Kingdom,
in accordance with the provisions of Article 11(1) (sealing of packages) of the Oil and Fibre Plant Seed Directive.

(2) In the case of a package of seed in respect of which the Scottish Ministers have issued an official certificate under regulation 14(3)—

- (a) paragraph (1)(a) shall apply as if the words “not later than at the time of sampling” were omitted; and
- (b) subject to sub-paragraph (a), the package of seed shall be sealed in accordance with paragraph (1)(a) within 7 days of the issue of the official certificate.

(3) If a package of seed which has been sealed in accordance with paragraph (1) is opened it may not be marketed in accordance with regulations 6(1), 9, 11 or 12 unless it is re-sealed or further re-sealed—

- (a) in Scotland by the Scottish Ministers or a licensed seed sampler with a sealing device in such a manner that when the package is opened the sealing device is broken and cannot be re-used; or
- (b) (i) in the United Kingdom but not in Scotland; or
 - (ii) in an EEA State other than the United Kingdom,
in accordance with the provisions of Article 11(2) (re-sealing of packages) of the Oil and Fibre Plant Seed Directive.

(4) No person shall market in accordance with regulations 6(1), 9, 11 or 12 a small package of Commercial Seed, Pre-basic Seed, Basic Seed, Seed of a Certified Generation, a varietal association to which regulation 9 applies, lower germination seed or early movement seed, unless it has been, or in the case of seed which is wholly or partly re-packaged, the original package has been, sealed by the Scottish Ministers, a licensed seed sampler or a person registered by a National Authority in any part of the United Kingdom as a seed merchant, seed packer or seed processor under regulation 4(1) (registration of seed merchants, seed packers and seed processors) of the Seeds (Registration, Licensing and Enforcement) Regulations 1985^(a) or provisions equivalent to that regulation, not later than at the time of sampling in the United Kingdom with a sealing device in such a manner that when the package is opened the sealing device is broken and cannot be re-used.

(5) If a small package of seed which has been sealed in accordance with paragraph (4) is opened, it may not be marketed in accordance with regulations 6(1), 9, 11 or 12 unless it is re-sealed or further re-sealed by the Scottish Ministers, a licensed seed sampler or a person registered by a National Authority in any part of the United Kingdom as a seed merchant, seed packer or seed processor under regulation 4(1) (registration of seed merchants, seed packers and seed processors) of the Seeds (Registration, Licensing

^(a) S.I. 1985/980, as relevantly amended by S.I. 1987/1098, 1990/611 and 1993/2530.

and Enforcement) Regulations 1985 or provisions equivalent to that regulation, with a sealing device, in such a manner that when the package is opened the sealing device is broken and cannot be re-used.

(6) No person shall market in accordance with regulation 6(1) a package of Breeder's Seed unless it is marketed in a package which has been sealed with a sealing device in such a manner that when the package is opened the sealing device is broken and cannot be re-used.

(7) If a package of Breeder's Seed which has been sealed in accordance with paragraph (6) is opened it may not be marketed in accordance with regulation 6(1) unless it is re-sealed or further re-sealed with a sealing device in such a manner that when the package is opened the sealing device is broken and cannot be re-used.

Labelling of packages of fully certified seed

17.—(1) Subject to regulation 18, no person shall market in accordance with regulations 6(1), 9, 11 or 12 any Commercial Seed, Pre-basic Seed, Basic Seed, Seed of a Certified Generation, a varietal association to which regulation 9 applies, lower germination seed or early movement seed, except in a package which, not later than at the time of sealing, is labelled, inscribed or otherwise dealt with in accordance with this regulation.

(2) In the case of a package of seed in respect of which the Scottish Ministers have issued an official certificate under regulation 14(3)—

- (a) paragraph (1) shall apply as if the words “not later than at the time of sealing” were omitted; and
- (b) subject to sub-paragraph (a), the package of seed shall be re-labelled in accordance with this regulation within 7 days of the issue of the official certificate.

(3) In the case of seed of a variety which has been genetically modified, any label, document, printing or stamp, whether official or otherwise, affixed to or accompanying a seed lot or any part of a seed lot in accordance with the provisions of this regulation, and any particulars given under regulation 18, shall clearly indicate that the variety has been genetically modified.

(4) A package of Breeder's Seed shall have affixed on the outside a label containing, as appropriate to the seed, particulars of the matters specified, and being of the colour also specified, in paragraph 3 of Part II of Schedule 6, which shall be either an adhesive label or tear-proof label and shall be affixed, in either case, not later than at the time of sealing.

(5) Subject to paragraph (10), a package (other than a small package sealed in the United Kingdom in accordance with regulation 16(4)) of Commercial Seed, Pre-basic Seed, Basic Seed, Seed of a Certified Generation, a varietal association of seed to which regulation 9 applies, lower germination seed or early movement seed—

- (a) which is sealed in Scotland shall have affixed on the outside an official label—
 - (i) containing, as appropriate to the category of seed and the seed itself, particulars of the matters specified, and being of at least the size and of the colour also specified, in the relevant paragraph of Part II of Schedule 6; and
 - (ii) which shall be either an adhesive label or a label secured to the package by a sealing device approved by the Scottish Ministers and shall be affixed, in either case, by the Scottish Ministers or a licensed seed sampler; and

- (b) which is sealed—
 - (i) in the United Kingdom but not in Scotland; or
 - (ii) in an EEA State other than the United Kingdom,
in accordance with the provisions of Articles 11(2) (re-sealing), 12(1)(a) (labelling of packages) and 18(c) (labelling of packages of Pre-basic Seed) of the Oil and Fibre Plant Seed Directive appropriate to the relevant category of seed and the seed itself.

(6) If in accordance with regulation 11 a person shall market any lower germination seed—

- (a) the official label shall contain a statement that the minimum percentage of germination of the seed is less than the minimum percentage of germination for Basic Seed; and

- (b) a label affixed to the outside of the package shall contain a statement of the specific minimum percentage of germination of the seed guaranteed by the person marketing the seed in accordance with regulation 11(2) together with the name and address of the seller and the reference number of the seed lot.

(7) If in accordance with regulation 12 a person shall market any early movement seed, a label affixed to the outside of the package shall contain—

- (a) a statement that the seed is being sold before the official examination of the germination of that seed lot has been concluded; and
- (b) a statement of the specific minimum percentage of germination guaranteed by the person marketing the seed in accordance with regulation 12(2)(c), together with the name and address of the seller and the reference number of the seed lot.

(8) Subject to paragraph (9), a package (other than a small package sealed in the United Kingdom in accordance with regulation 16(4)) of Commercial Seed, Pre-basic Seed, Basic Seed, Seed of a Certified Generation, a varietal association of seed to which regulation 9 applies, lower germination seed or early movement seed—

- (a) which is sealed in Scotland shall contain an official inner label which shall be of the same colour as, and in addition to, the official label affixed to the outside of the package in accordance with paragraph (5) and shall contain particulars of the matters specified in the items numbered—
 - (i) in the case of Pre-basic Seed and lower germination seed to which paragraph 4 of Part II of Schedule 6 is relevant, paragraph 4(a)(iii) to (v) of Part II of Schedule 6;
 - (ii) in the case of Basic Seed, Seed of a Certified Generation, or lower germination seed to which paragraph 5 of Part II of Schedule 6 is relevant, paragraph 5(a)(iv) to (vi) of Part II of Schedule 6;
 - (iii) in the case of Commercial Seed, paragraph 6(a)(iv) to (vi) of Part II of Schedule 6; and
 - (iv) in the case of a varietal association to which regulation 9 applies, paragraph 7(a)(iv) to (vi) of Part II of Schedule 6; and
- (b) which is sealed in—
 - (i) the United Kingdom but not in Scotland; or
 - (ii) an EEA State other than the United Kingdom,shall contain an official document in accordance with Article 12(1)(b) (official documents) of the Oil and Fibre Plant Seed Directive.

(9) The official inner label or document referred to in paragraph (8) shall not be required if the particulars specified in paragraphs (3), (8) and (13) are printed indelibly on the outside of the package or if the official label is an adhesive or a tear-resistant label.

(10) Notwithstanding paragraph (5), but subject to paragraphs (6) and (7), a package (other than a small package sealed in the United Kingdom in accordance with regulation 16(4)) of Commercial Seed, Basic Seed, Seed of a Certified Generation, a varietal association of seed to which regulation 9 applies, lower germination seed or early movement seed may be marketed if—

- (a) the appropriate particulars of the matters specified in Part II of Schedule 6 and paragraphs (3), (12) and (13) for packages sealed in Scotland, and in Articles 5 (lower germination and early movement seed), 11(2) (re-sealing) 12(1)(a) (labelling) and 14 (identification of genetically modified varieties) and Annex IV (labels) of the Oil and Fibre Plant Seed Directive for packages sealed in either—
 - (i) the United Kingdom but not Scotland; or
 - (ii) an EEA State other than the United Kingdom,are printed or stamped indelibly on the package in a panel of at least the size and of the colour so specified; and
- (b) the requirements of paragraphs 11 to 16 of Part VI of Schedule 6 are satisfied, in the case of a package sealed in Scotland; and

- (c) the requirements of paragraph 17 of Part VI of Schedule 6 are satisfied in the case of a package sealed in either–
- (i) the United Kingdom but not in Scotland; or
 - (ii) an EEA State other than the United Kingdom.

(11) A small package sealed in the United Kingdom shall have affixed on the outside a label containing, as appropriate to the category of the seed and the seed itself, particulars of the matters specified in paragraphs (3), (12) and (13) and the relevant paragraph of Part II of Schedule 6, and being of the colour specified in the relevant paragraph of Part II of Schedule 6, except that subject to paragraphs (6) and (7)–

- (a) if such particulars are printed indelibly on the outside of the package in a panel of the colour so specified, the label shall not be required; and
- (b) if the packaging material is transparent the label may be placed inside the package provided it can be read through the packaging.

(12) Subject to paragraph (10) or (11), if a package of seed has been re-sealed in accordance with regulation 16(3) or 20(4) this fact shall be stated on the official label required under paragraph (5) or the label required under paragraph (11), as the case may be, together with the month and year of re-sealing and the name of the authority responsible for the re-sealing.

(13) If any seed has been subjected to any chemical treatment this fact and the nature of the treatment or the proprietary name of the chemical used in the treatment shall be stated either–

- (a) in a case where regulation 18 applies, with the particulars given in accordance with that regulation;
- (b) in a case where regulation 18 does not apply–
 - (i) on a separate label on the package; or
 - (ii) on the label referred to in paragraph (4), (5) or (11), the official inner label or document referred to in paragraph (8), or the printing or stamp referred to in paragraph (9), (10) or (11),

and also, except where the information prescribed by this paragraph is given on an adhesive or tear-resistant label, either on the outside of the package or on a document enclosed inside the package.

(14) The particulars and information given in accordance with this regulation shall be given in one of the official languages of the European Community.

(15) Subject to the provisions of the Act and of these Regulations, no person shall, in the course of the marketing or the preparation for marketing of any seed by that person or by any other person, wilfully reproduce, remove, alter, deface, conceal or misuse in any way any label affixed to, contained in or marked on any package of seed or which is to be so affixed, contained or marked.

Marketing of unpacked seed

18. Subject to regulation 17(3) and (13) a person may sell any seed otherwise than in a package which is sealed, labelled, inscribed or otherwise dealt with in accordance with regulations 16 and 17 where–

- (a) the seed is sold in a quantity not exceeding 5 kilograms to the final consumer; and
- (b) the seed is taken, in the presence of the final consumer, from a container on which there is clearly and visibly marked, or near which there is clearly and visibly displayed, a statement containing particulars of the matters specified in paragraph 9 of Part IV of Schedule 6.

PART V

PROCEDURES FOR ISSUING BREEDER'S CONFIRMATIONS

Breeder's confirmations

19.—(1) An application for the issue of a breeder's confirmation for Pre-basic Seed or Basic Seed in respect of a seed lot–

- (a) shall be made in writing by the breeder to the Scottish Ministers in such form and manner, and shall include such information, records, illustrations, material and seed, as the Scottish Ministers may require; and
- (b) shall be made not later than 31st December in the year following the year of harvest of the crop from which the seed lot is obtained or within such other time as the Scottish Ministers may allow; and
- (c) shall be made only—
 - (i) for seed of a variety for which an application has been made to have that variety accepted on to a UK National List (or an equivalent list in another EEA State); or
 - (ii) for seed of a component of a hybrid variety of oilseed rape for which hybrid variety an application has been made to have that hybrid variety accepted on to a UK National List (or to an equivalent list in another EEA State).

(2) Where an application for the issue of a breeder's confirmation is made to the Scottish Ministers in accordance with paragraph (1) the Scottish Ministers shall deal with the application in accordance with the provisions of Part II of Schedule 2.

(3) A breeder's confirmation which has been issued by the Scottish Ministers may be withdrawn by them in respect of either the whole of a seed lot or any part of a seed lot if—

- (a) the results of an official examination of the sample taken from the seed lot in respect of which the breeder's confirmation has been issued are declared null and void in accordance with regulation 15(2);
- (b) on the basis of information received by them, the Scottish Ministers are satisfied that the crop from which the seed in the seed lot was harvested did not meet the conditions specified in Part I of Schedule 4; or
- (c) on the basis of information received by them, the Scottish Ministers are satisfied that the seed in the seed lot, or part of the seed lot—
 - (i) did not meet the conditions laid down in Part II of Schedule 4 at the time the seed was tested for breeder's confirmation purposes; or
 - (ii) although it met the conditions in Part II of Schedule 4 at the time of such testing no longer meets them,

and any seed from which a breeder's confirmation has been so withdrawn shall be deemed not to have had a breeder's confirmation.

(4) The Scottish Ministers may withdraw the breeder's confirmation in respect of a seed lot, or any part of a seed lot, by giving notice to the person who made an application in respect of the seed lot under paragraph (1).

PART VI

PACKAGING AND LABELLING REQUIREMENTS RELATING TO BREEDER'S CONFIRMATION

Sealing of packages of seed in relation to breeder's confirmation

20.—(1) No person shall have in their possession any package of seed in respect of which a breeder's confirmation for Pre-basic Seed or Basic Seed has been applied for or issued unless it has been sealed in accordance with this regulation by the Scottish Ministers or a licensed seed sampler with a sealing device in such manner that when the package is opened the sealing device will be broken and cannot be re-used.

(2) Sealing under paragraph (1) shall take place not later than at the time of sampling or, in the case of seed which is wholly or partly re-packaged, the sealing of the original package shall take place no later than that time.

(3) Subject to paragraph (4), no person shall open a package of seed which has been sealed in accordance with paragraph (1) or re-sealed in accordance with paragraph (4) except—

- (a) for the purpose of sowing all the seed;
- (b) where—
 - (i) some of the seed is sown immediately after the package is opened;
 - (ii) the rest of the seed remains in the package after the seed is sown in accordance with subparagraph (i); and
 - (iii) the package is re-sealed immediately after the seed is sown in accordance with subparagraph (i); or
- (c) for the purpose of re-packaging and re-sealing all of the seed.

(4) If a package of seed which has been sealed in accordance with paragraph (1), or re-sealed in accordance with this paragraph, is in accordance with paragraph (3) or otherwise, opened neither it nor any other package containing any of that seed may be sealed, re-sealed or further re-sealed, as the case may be, except by the Scottish Ministers or a licensed seed sampler.

(5) If the details on any label required by regulation 21 cease to be correct as a consequence of any action of the kind described in paragraph (3) the label shall be replaced by the Scottish Ministers or a licensed seed sampler at the time the package is re-sealed under paragraph (4).

Labelling of packages of seed in relation to breeder's confirmation

21.—(1) No person shall have in their possession any package of seed in respect of which a breeder's confirmation has been applied for unless it has been, not later than the time of sealing under regulation 20, labelled, inscribed or otherwise dealt with in accordance with this regulation.

(2) In the case of seed of a variety which has been genetically modified, any label, document, printing or stamp, whether official or otherwise, affixed to or accompanying a seed lot or any part of a seed lot in accordance with the provisions of this regulation, shall clearly indicate that the variety has been genetically modified.

(3) Packages of seed in respect of which a breeder's confirmation has been applied for shall have affixed on the outside an official label—

- (a) containing, as appropriate to the category of seed and the seed itself, particulars of the matters specified, and being of at least the size and of the colour also specified, in the relevant paragraph of Part II of Schedule 6; and
- (b) which shall be—
 - (i) either an adhesive label or a label secured to the package by a sealing device approved by the Scottish Ministers;
 - (ii) affixed, in either case, by the Scottish Ministers or a licensed seed sampler; and
 - (iii) over stamped “not certified”.

(4) If in accordance with paragraphs 5 and 6(c) of Part II of Schedule 2 a breeder's confirmation has been issued in respect of seed of a lower percentage of germination than that specified for Basic Seed in Part II of Schedule 4—

- (a) the official label, or the particulars printed or stamped on the package in accordance with paragraph (5), shall contain a statement that the minimum percentage of germination of the seed is less than the minimum percentage of germination for Basic Seed; and
- (b) where possession of the package is transferred to another person, the transferor shall—
 - (i) guarantee a specific minimum percentage of germination of the seed; and
 - (ii) affix a label to the outside of the package containing a statement of the specific minimum percentage of germination of the seed guaranteed by the person transferring possession of the seed together with the name and address of the transferor and the reference number of the seed lot.

(5) Notwithstanding paragraphs (2) to (4) and (9), a package of seed need not be labelled if–

- (a) the appropriate particulars of the matters specified in the relevant paragraph of Part II of Schedule 6 and paragraphs (2), (4), (8) and (9) are printed or stamped indelibly on the package in a panel of at least the size and of the colour so specified and over-stamped “not certified”; and
- (b) the requirements of paragraphs 11 to 14 and 16 of Part VI of Schedule 6 are satisfied.

(6) Subject to paragraph (7), a package of seed for which a breeder’s confirmation has been issued shall contain an official inner label which shall be of the same colour as, and in addition to, the official label affixed to the outside of the package in accordance with paragraph (3) and shall contain particulars of the matters specified in the items numbered–

- (i) in the case of Pre-basic Seed and lower germination seed to which paragraph 4 of Part II of Schedule 6 is relevant, paragraph 4(a)(iii) to (v) of Part II of Schedule 6; and
- (ii) in the case of Basic Seed and lower germination seed to which paragraph 5 of Part II of Schedule 6 is relevant, paragraph 5(a)(iv) to (vi) of Part II of Schedule 6.

(7) The official inner label referred to in paragraph (6) shall not be required if the particulars specified in paragraphs (2), (6) and (8) are printed indelibly on the outside of the package or if the official label is an adhesive or tear-resistant label.

(8) If a package of seed has been re-sealed in accordance with regulation 20(4) this fact shall be stated on the official label required in terms of paragraph (3), and if an official certificate is issued in respect of the seed, on the official label required in terms of regulation 17(12), together with the month and year of re-sealing and the name of the authority responsible for the re-sealing.

(9) If any seed has been subjected to any chemical treatment this fact and the nature of the treatment or the proprietary name of the chemical used in the treatment shall be stated either–

- (a) on a separate label on the package; or
- (b) on the label referred to in paragraph (3) or (4) or the printing or stamp referred to in paragraph (5),

and also, except where the information prescribed by this paragraph is given on an adhesive or tear-resistant label, either on the outside of the package or as a document enclosed inside the package.

(10) The particulars and information given in accordance with this regulation shall be given in one of the official languages of the European Community.

(11) For the purposes of this regulation, references in Schedule 6 to the “certifying authority” shall, in the case of a breeder’s confirmation, be taken to be references to that authority as issuer of the breeder’s confirmation.

(12) Subject to the provisions of the Act and of these Regulations, no person shall wilfully reproduce, remove, alter, deface, conceal or misuse in any way any label affixed to, contained in or marked on any package of seed or which is to be so affixed, contained or marked, except as may occur in the course of opening the package for the purposes of regulation 17(2)(b) or 20(3).

PART VII

MISCELLANEOUS

Comparative tests and trials

22. For the purposes of comparative tests and trials under Article 23 (comparative tests and trials) of the Oil and Fibre Plant Seed Directive, the Scottish Ministers shall be entitled, on request, to an additional submitted sample taken from any seed lot of seed to which these Regulations apply whenever that seed lot is sampled for the purposes of–

- (a) an official examination under these Regulations; or
- (b) for the purposes of an examination or test carried out by a National Authority or a licensed seed testing station under the Oil and Fibre Plant Seeds Regulations 1993(a).

(a) S.I. 1993/2007 as relevantly amended by S.I. 1994/1423, 1996/1451, 1997/616, 1999/1862, S.S.I. 2000/249, S.I. 2001/3510 and S.S.I. 2003/304.

Civil liabilities of sellers of seed

23.—(1) The particulars given to a purchaser by the seller of seed to which these Regulations apply, whether given in pursuance of these Regulations expressly or by implication arising from the description under which the seed is sold, shall constitute a statutory warranty for the purpose of section 17 of the Act in so far as they relate to the category of the seed, the percentage germination of the seed, the percentage analytical purity of the seed, the content of seed of other plant species, the varietal identity and the varietal purity of the seed or, in the case of a mixture of seed permitted by regulation 7, of each of its constituents to which these Regulations apply.

(2) Section 17(2) of the Act shall apply to any particulars given to a purchaser by the seller of seed, being particulars given or implied as in paragraph (1), in so far as they relate to the percentage germination, the percentage analytical purity, or the content of seed of other plant species and there are hereby prescribed in respect of such matters the limits of variation set out in Schedule 7.

(3) Section 17(3) of the Act shall apply to any particulars given to a purchaser by the seller of the seed, being particulars given or implied as in paragraph (1), in so far as they relate to the percentage germination, the percentage analytical purity or the content of seed of other plant species.

(4) A purchaser who intends to obtain a test of seed for the purposes of section 17(3) of the Act shall, not more than 10 days after delivery to that purchaser of the seed, give to the seller written notice of the purchaser's intention and thereupon the seller may indicate a day (not being more than 21 days after delivery of the seed to the purchaser) and a reasonable time on that day at which a sample of the seed may be taken in the presence of the seller or the seller's representative and the purchaser shall afford to the seller reasonable facilities for that purpose.

(5) On the day and at the time appointed by the seller in accordance with paragraph (4) or, if the seller fails to appoint such a day and time, on a day not more than 28 days after delivery of the seed to the purchaser, the purchaser or the purchaser's representative may, and if the seller or the seller's representative is present shall, take a sample from the relevant seed lot or part of a seed lot sold to the purchaser, which sample shall be at least twice the minimum weight prescribed in paragraph 24 of Part II of Schedule 5.

(6) A sample taken in accordance with the requirements of paragraph (5) shall be taken, and divided by the purchaser or the purchaser's representative into two parts in accordance with the methods specified in Part I of Schedule 5, each part being of at least the minimum weight prescribed in paragraph 24 of Part II of Schedule 5, of which one part shall be sent to the Chief Officer of the Official Seed Testing Station for Scotland for the purpose of being tested and the other part delivered or tendered to the seller or the seller's representative or, if the seller or the seller's representative was not present when the sample was taken, sent to the seller by post.

Service of notices

24.—(1) Any notice required by virtue of these Regulations to be given to any person by the Scottish Ministers may be given by them—

- (a) by delivering it to that person or by leaving it at that person's proper address or by sending it by post to that person at that address;
- (b) if the person is a body corporate other than a limited liability partnership, by giving it in accordance with sub-paragraph (a) to the secretary of the body;
- (c) if the person is a limited liability partnership, by giving it in accordance with sub-paragraph (a) to a member of the partnership; or
- (d) if the person is a partnership, by giving it in accordance with sub-paragraph (a) to a partner or a person having control of the management of the partnership business.

(2) For the purposes of this regulation and section 7 (service of documents by post) of the Interpretation Act 1978(a) in its application to this section, the proper address of any person to whom a notice is to be given shall be that person's last known address, except that—

(a) 1978 c.30.

- (a) in the case of a seed merchant, seed packer or seed processor registered under regulation 4(1) (registration of seed merchants, seed packers and seed processors) of the Seeds (Registration, Licensing and Enforcement) Regulations 1985^(a) or a licensed crop inspector who has a current licence granted by the Scottish Ministers or a licensed seed sampler who has a current licence granted by the Scottish Ministers, it shall be the address which could be made available by the Scottish Ministers under regulation 13(a) (inspection and publication of lists of registered and licensed persons) of the Seeds (Registration, Licensing and Enforcement) Regulations 1985; and
- (b) in other cases it shall be—
 - (i) in the case of a body corporate (other than a limited liability partnership) or its secretary, the address of the registered or principal office of the body;
 - (ii) in the case of a limited liability partnership or a member of the partnership, the address of the registered or principal office of the partnership; and
 - (iii) in the case of a partnership or a partner or a person having the control or management of a partnership business, the address of the principal office of the partnership.

(3) Paragraph (4) applies if a person to be given a notice under these Regulations by the Scottish Ministers has specified to them an address within the United Kingdom other than that person's proper address (as determined under paragraph (2)) as the one at which that person or someone on that person's behalf will accept notices of that description.

(4) In relation to that notice, that address shall be treated as that person's proper address for the purposes of this regulation and section 7 (service of documents by post) of the Interpretation Act 1978 in its application to this regulation, instead of that determined under paragraph (2).

Written and electronic communication

25.—(1) All applications, approvals, authorisations, notices, notifications and statements to which these Regulations apply shall be made in writing.

(2) "Writing" in paragraph (1) includes an electronic communication as defined in the Electronic Communications Act 2000^(b), which has been recorded and is consequently capable of being reproduced, provided that—

- (a) any document of the type referred to in paragraph (1) shall only be sent to the Scottish Ministers by an electronic communication if the Scottish Ministers have represented that electronic communication is a means by which persons can send such a document to them; and
- (b) notifications required to be sent by the Scottish Ministers to any person shall only be made by an electronic communication if the intended recipient has used the same form of electronic communication in communicating with the Scottish Ministers for the purpose of these Regulations or has otherwise represented that that form of electronic communication is a means by which the Scottish Ministers can communicate with them.

Amendment to the Seeds (Fees) (Scotland) Regulations 2002

26. In Schedule 3 (matters arising under the Oil and Fibre Plant Seeds Regulations 1993) of the Seeds (Fees) (Scotland) Regulations 2002^(c) for "Oil and Fibre Plant Seeds Regulations 1993" substitute "Oil and Fibre Plant Seed (Scotland) Regulations 2004^(d)".

Revocations and transitional provisions

27.—(1) Subject to paragraph (2), the Regulations set out in column 1 of Schedule 8 are revoked to the extent specified in the corresponding entry in relation to those Regulations in column 3 of Schedule 8.

(2) Subject to regulation 5 and paragraph (3), the provisions of these Regulations shall—

^(a) S.I. 1985/980, as relevantly amended by S.I. 1987/1098, 1990/611 and 1993/2530.

^(b) 2000 c.7.

^(c) S.S.I. 2002/526.

^(d) S.S.I.2004/317.

- (a) apply to hemp seed, varietal associations of seed and seed of hybrid varieties, from the coming into force date of these Regulations; and
 - (b) not apply to seed other than seed to which paragraph (2)(a) applies, harvested on or before the coming into force date of these Regulations until 1st July 2005.
- (3) Subject to regulation 5, regulation 22 shall apply to all seed from the coming into force date of these Regulations.
- (4) Section 17 (repeal and re-enactment) of the Interpretation Act 1978 shall not apply in relation to general licences granted under the Oil and Fibre Plant Seeds Regulations 1993.

St Andrew's House,
Edinburgh
1st July 2004

ROSS FINNIE
A member of the Scottish Executive

SCHEDULE 1

Regulations 2(1) and 5(1)

SPECIES OF SEED TO WHICH THE REGULATIONS APPLY

Column 1 Common Name	Column 2 Latin Name
Black mustard	<i>Brassica nigra</i> (L.) Koch
Brown mustard	<i>Brassica juncea</i> (L.) Czernj. et Cosson
Hemp(a)	<i>Cannabis sativa</i> L.
Flax	<i>Linum usitatissimum</i> L.
Linseed	<i>Linum usitatissimum</i> L.
Soya bean	<i>Glycine max</i> (L.) Merr.
Sunflower	<i>Helianthus annuus</i> L.
Swede rape(b)	<i>Brassica napus</i> L. (<i>partim</i>)
Turnip rape	<i>Brassica rapa</i> L. var. <i>silvestris</i> (Lam.) Briggs
White mustard	<i>Sinapis alba</i> L.

(a) See regulation 2(1) for the definitions of “dioecious hemp”, “hemp” and “monoecious hemp”.

(b) See regulation 2(1) for the definition of “swede rape”.

OFFICIAL CERTIFICATES AND BREEDER'S CONFIRMATIONS

PART I

OFFICIAL CERTIFICATES

Applications for seed harvested in the United Kingdom

1. On receipt of an application made in accordance with regulation 14(1) but not made in pursuance of Article 19 (certification of seed from other EEA States or equivalent third countries) of the Oil and Fibre Plant Seed Directive for the issue of an official certificate in respect of a seed lot as Pre-basic Seed(a), Basic Seed(b), Seed of a Certified Generation(c) or Commercial Seed(d), the Scottish Ministers shall, subject to paragraphs 2 and 3, issue in respect of such a seed lot an official certificate containing the particulars specified in paragraph 1 of Schedule 3.

When applications will be refused

2. The Scottish Ministers shall refuse to issue an official certificate in respect of a seed lot unless—

- (a) an application has been made to the Scottish Ministers, in writing in such form and manner and at such time as the Scottish Ministers may require, and has been accompanied by such information material, records, illustrations and other documents as they may require, in respect of—
 - (i) the seed lot or seed lots to be used for the production of the crop or crops from which is to be or has been obtained the seed lot in respect of which the application for an official certificate has been made; and
 - (ii) the crop or crops from which the seed lot is to be or has been obtained;
- (b) an official examination of the crop or crops from which was obtained the seed lot in respect of which the application for an official certificate has been made has shown that the crop or crops met the standards appropriate to the category of seed referred to in the application specified in Part I of Schedule 4; and
- (c) an official examination of a sample of the seed lot has shown that the seed lot meets the standards appropriate to the relevant category of seed referred to in the application specified in Part II of Schedule 4,

except that—

- (i) paragraphs 2(a) and (b) shall not apply in relation to an application for the issue of an official certificate in respect of Commercial Seed; and
- (ii) paragraph 2(c), in so far as it relates to standards of percentage of germination specified in paragraph 13 of Part II of Schedule 4, shall not apply in relation to an application for the issue of an official certificate in respect of lower germination seed.

When applications may be refused

3. The Scottish Ministers may refuse to issue an official certificate in respect of a seed lot if it appears to them that—

(a) See regulation 3 for the definition of "Pre-basic Seed".
(b) See regulation 3 for the definition of "Basic Seed".
(c) See regulation 3 for the definition of "Seed of a Certified Generation".
(d) See regulation 3 for the definition of "Commercial Seed".

- (a) a sample taken from the seed lot for the purpose of an official examination to ascertain whether the seed lot meets the appropriate standards specified in Part II of Schedule 4 has not been taken in accordance with regulation 15(1);
- (b) an official examination of a control plot sown with a sample of the seed lot sown in the field shows that the crop does not meet the appropriate standards specified in Part I of Schedule 4; or
- (c) there has been any breach of seeds regulations in relation to the seed lot in respect of which the application for an official certificate has been made.

Applications for seed harvested in an EEA State or third country

4. Notwithstanding paragraphs 2 and 3, on receipt of an application made in accordance with regulation 14(1) and in pursuance of Article 19 (certification of seed from other EEA States or equivalent third countries) of the Oil and Fibre Plant Seed Directive for the issue of an official certificate in respect of a seed lot as Pre-basic Seed, Basic Seed, Seed of a Certified Generation or Commercial Seed, the Scottish Ministers shall issue in respect of the seed lot an official certificate containing the particulars specified in paragraph 1 of Schedule 3 if–

- (a) the seed has been–
 - (i) produced directly from fully certified Basic Seed, Certified Seed of the First Generation^(a) or seed certified in a third country which is permitted to be sold as Basic Seed or Certified Seed of the First Generation by virtue of a general licence granted by the Scottish Ministers under regulation 5(1)(b)(iii) (general licences) or 5(3) (general licences) of the Oil and Fibre Plant Seeds Regulations 1993^(b) or regulation 10; and
 - (ii) harvested in an EEA State other than the United Kingdom or in a third country; or
- (b) the seed has been–
 - (i) produced directly from the crossing of fully certified Basic Seed with seed certified in a third country which is permitted to be sold as Basic Seed by virtue of a general licence granted by the Scottish Ministers under regulation 5(1)(b)(iii) (general licences) or 5(3) (general licences) of the Oil and Fibre Plant Seeds Regulations 1993 or regulation 10 or the implementation of the Equivalence Decision; and
 - (ii) harvested in an EEA State other than the United Kingdom or in a third country; or
- (c) the seed–
 - (i) is to be certified by the Scottish Ministers as Basic Seed;
 - (ii) has been produced directly from fully certified Pre-basic Seed or from seed certified in a third country which is permitted to be sold as Pre-basic seed by virtue of a general licence granted by the Scottish Ministers under regulation 5(1)(b)(iii) (general licences) or 5(3) (general licences) of the Oil and Fibre Plant Seeds Regulations 1993 or regulation 10 or the implementation of the Equivalence Decision; and
 - (iii) has been harvested in an EEA State other than the United Kingdom or in a third country; and

provided that–

- (d) if the seed has been harvested in an EEA State other than the United Kingdom–
 - (i) the seed has been harvested from a crop which has been found by field examination of the crop carried out by the competent seed certification authority in the EEA State; or
 - (ii) in the case of a seed lot which is to be certified by the Scottish Ministers as Seed of a Certified Generation, seed which has been harvested from a crop which has been produced from seed that has undergone official post-control the results of which have been satisfactory, by a field examination of the crop carried out by a licensed EC crop inspector,
 to satisfy the crop conditions specified in Annex I (crop standards) of the Oil and Fibre Plant Seed Directive for the relevant category of seed;

^(a) See regulation 3 for the definition of “Certified Seed of the First Generation”.

^(b) S.I. 1993/2007, as relevantly amended by S.I. 1994/1423, 1996/1451, 1997/616, 1999/1862, S.S.I. 2000/249, S.I. 2001/3510 and S.S.I. 2003/304.

- (e) if the seed has been harvested in a third country, the seed has been harvested from a crop which has been found by field examination satisfying the conditions specified in the Equivalence Decision to satisfy the conditions specified in Annex I (crop standards) of the Oil and Fibre Plant Seed Directive for the relevant category of seed;
- (f) if the seed has been harvested in an EEA State, the seed has been packed in a sealed package in accordance with the requirements of Article 11(1) (sealing) of the Oil and Fibre Plant Seed Directive and has been labelled in accordance with the requirements of the second indented subparagraph of the first paragraph of Article 19(2) (labelling requirements for certification of seed from other EEA States or equivalent third countries) of the Oil and Fibre Plant Seed Directive;
- (g) if the seed has been harvested in an EEA State, has been imported into the United Kingdom as not finally certified seed;
- (h) is accompanied by an Annex V(C) document relating to the seed issued by the competent seed certification authority in the EEA State; and
- (i) official examination has shown that the conditions specified in Part II of Schedule 4 for the relevant category of seed have been satisfied.

PART II

BREEDER'S CONFIRMATIONS

Applications

5. On receipt of an application made in accordance with regulation 19(1) for the issue of a breeder's confirmation in respect of a seed lot, as Pre-basic Seed or Basic Seed, the Scottish Ministers shall, subject to paragraphs 6 and 7, issue in respect of that seed lot a breeder's confirmation containing the particulars specified in paragraph 2 of Schedule 3.

When applications will be refused

6. The Scottish Ministers shall refuse to issue a breeder's confirmation in respect of a seed lot unless—
- (a) an application has been made to the Scottish Ministers in writing in such form and manner and at such time as the Scottish Ministers may require, and has been accompanied by such information, material, records, illustrations and other documents as they may require, in respect of—
 - (i) the seed lot or seed lots to be used for the production of the crop or crops from which is to be or has been obtained the seed lot in respect of which the application for a breeder's confirmation has been made; and
 - (ii) the crop or crops from which the seed lot is to be or has been obtained;
 - (b) an official examination of the crop or crops from which was obtained the seed lot in respect of which the application for a breeder's confirmation has been made has shown that the crop or crops meet the standards specified in Part I of Schedule 4 appropriate in the category referred to in the application; and
 - (c) an official examination of a sample taken from the seed lot has shown that the seed lot meets the standards specified in Part II of Schedule 4 appropriate to the relevant category of seed referred to in the application except that a breeder's confirmation can be issued for Pre-basic Seed or Basic Seed in respect of seed which attains a lower percentage of germination than that specified in paragraph 13 of Part II of Schedule 4.

When applications may be refused

7. The Scottish Ministers may refuse to issue a breeder's confirmation in respect of a seed lot if it appears to them that—

- (a) a sample taken from the seed lot for the purpose of an official examination to ascertain whether the seed lot meets the appropriate standards specified in Part II of Schedule 4 has not been taken in accordance with regulation 15(1);
- (b) an official examination of a control plot sown with a sample of the seed lot sown in the field shows that the crop does not meet the appropriate standards specified in Part I of Schedule 4;
- (c) there has been a breach of seeds regulations in relation to the seed lot in respect of which application for a breeder's confirmation has been made.

SCHEDULE 3

Regulation 2(1), paragraphs 1 and 4
of Part I of Schedule 2 and paragraph 5
of Part II of Schedule 2

PARTICULARS TO BE SPECIFIED IN AN OFFICIAL CERTIFICATE OR A BREEDER'S CONFIRMATION

Particulars to be specified in an official certificate

1. The following particulars shall be specified in an official certificate:—

- (a) name and address of certifying authority;
- (b) applicant's name, address and, if appropriate, registered number;
- (c) seed lot reference number;
- (d) species/variety/category, as appropriate;
- (e) net weight of seed lot and number of containers; and
- (f) seed treatment, if any.

Particulars to be specified in a breeder's confirmation

2. The following particulars shall be specified in a breeder's confirmation:—

- (a) name and address of issuing authority;
- (b) applicant's name, address and, if appropriate, registered number;
- (c) seed lot reference number;
- (d) species/variety/category, as appropriate;
- (e) net weight of seed lot and number of containers;
- (f) seed treatment, if any; and
- (g) statement that the breeder's confirmation does not constitute an official certificate and does not permit marketing of the seed.

SCHEDULE 4

Regulations 2(1), 3, 6(2), 11(1), 12(1),
(2) and (3), 21(4) and paragraphs 2, 3 and
4 of Part I of Schedule 2 and paragraphs 6
and 7 of Part II of Schedule 2

REQUIREMENTS FOR BASIC SEED, CERTIFIED SEED, CERTIFIED SEED OF THE FIRST GENERATION, CERTIFIED SEED OF THE SECOND GENERATION, CERTIFIED SEED OF THE THIRD GENERATION AND COMMERCIAL SEED

PART I

CONDITIONS RELATING TO CROPS FROM WHICH SEED OTHER THAN COMMERCIAL SEED IS OBTAINED

Methods of crop testing

1. The Scottish Ministers may ascertain, so far as practicable, whether the requirements for the crop set out in this Part of this Schedule are met by the use of methods which shall include official field inspection of the crop and which may include examination of a control plot sown with a sample from the seed lot sown in the field and the consideration of any other relevant information.

Varietal identity and varietal purity

2. The characteristics used for the determination of varietal identity and varietal purity shall be those to which regard was had when the relevant variety was accepted on to the relevant UK National List, an equivalent list in another EEA State or the Common Catalogue.

Crop inspection

3. (a) An official examination of the crop shall be made by means of an official field inspection.
- (b) The official field inspection shall only be carried out when the cultural condition of the field and the stage of development and condition, including state of health, of the crop are such as to permit suitable checks of varietal identity, varietal purity and species purity to be made.
- (c) Subject to paragraphs (d) and (e), at least one official field inspection of the crop shall be carried out.
- (d) At least two official field inspections shall be carried out in the case of a hybrid of sunflower.
- (e) At least three official field inspections shall be carried out in the case of a hybrid of swede rape and shall be carried out as follows:—
- (i) the first official field inspection shall be carried out before the flowering stage;
 - (ii) the second official field inspection shall be carried out at the early flowering stage; and
 - (iii) the third official field inspection shall be carried out at the end of the flowering stage.

Harmful organisms in the crop

4. Harmful organisms which reduce the usefulness of the seed shall be at the lowest possible level including in the case of soya bean, *Pseudomonas syringae* pv *glycinea*, *Diaporthe phaseolorum* var. *caulivora* and var. *sojae*, *Phialophora gregata* and *Phytophthora megasperma* f.sp. *glycinea*.

Previous cropping

5. (a) The previous cropping of the field shall not have been incompatible with the production of seed of the species and variety of the crop, and the field shall be sufficiently free from plants which are volunteers from previous cropping.
- (b) The crop may be grown only on land which complies with the Scottish Ministers' requirements in respect of previous cropping.
- (c) In the case of a hybrid of swede rape the crop shall be raised in a production ground where not less than 5 years have elapsed since plants of *cruciferae* were last grown.

Isolation distances - general

6. There shall be either a physical barrier or at least 2 metres of fallow ground between the seed crop and any crop likely to cause contamination in the seed.

Isolation distances - minimum distance

7. For black mustard, brown mustard, hemp, sunflower, swede rape, turnip rape and white mustard, the minimum distance from neighbouring crops or plants of other species, or of other varieties of the same species, liable to cross-pollinate with the crop shall be the distance specified in column 2 of the following table for the corresponding crop specified in column 1 of the table (which can include any distance of at least 2 metres of fallow ground required under paragraph 6 of this Part of this Schedule):–

Column 1 Crop	Column 2 Minimum Distance
(a) Black mustard, brown mustard, dioecious hemp, turnip rape and white mustard–	
(i) for the production of Basic Seed	400 metres
(ii) for the production of Certified Seed ^(a)	200 metres
(b) Monoecious hemp–	
(i) for the production of Basic Seed	5,000 metres
(ii) for the production of Seed of a Certified Generation	1,000 metres
(c) Sunflower–	
(i) for the production of Basic Seed of hybrids	1,500 metres
(ii) for the production of Basic Seed of varieties other than hybrids	750 metres
(iii) for the production of Seed of a Certified Generation	500 metres
(d) Swede rape–	
(i) for the production of Basic Seed of varieties other than hybrids	400 metres
(ii) for the production of Basic Seed of hybrids	500 metres
(iii) for the production of Certified Seed of varieties other than hybrids	200 metres
(iv) for the production of Certified Seed of hybrids	300 metres

but with the approval of the Scottish Ministers these distances may be modified or disregarded if there is adequate protection against undesirable foreign pollen.

^(a) See regulation 3 for the definition of "Certified Seed".

Standards for varietal purity

8. (a) The crop shall have sufficient varietal identity and varietal purity, including–
- (i) in the case of a crop of an inbred line, sufficient varietal identity and varietal purity as regards its characteristics; and
 - (ii) in the case of a crop used for the production of seed of hybrid varieties, sufficient varietal identity and varietal purity as regards the characteristics of the components of the hybrid variety, including male sterility or fertility restoration.
- (b) in crops of black mustard, brown mustard and hemp the number of plants of the crop species which are recognisable as obviously not being true to the variety shall not exceed–
- (i) one plant in 30 square metres for the production of Basic Seed; and
 - (ii) one plant in 10 square metres for the production of Seed of a Certified Generation.
- (c) in crops of hybrids of sunflower–
- (i) the percentage by number of plants which are recognisable as obviously not being true to the inbred line or to the component shall not exceed the percentage specified in column 2 of the following table corresponding to the relevant crop specified in column 1 of the table:–

Column 1 Crop of hybrid of sunflower	Column 2 Percentage by number of plants
(aa) For the production of Basic Seed–	
(aaA) inbred lines	0.2%
(aaB) simple hybrids–	
(aaBa) male parent, plants which have shed pollen while 2% or more of the female plants have receptive flowers	0.2%
(aaBb) female parent	0.5%
(bb) For the production of Certified Seed–	
(bbA) male component, plants which have shed pollen while 5% or more of the female plants have receptive flowers	0.5%
(bbB) female component	1.0%

- (ii) used for the production of seed of hybrid varieties–
 - (aa) sufficient pollen shall be shed by the plants of the male component while the plants of the female component are in flower;
 - (bb) where the female component plants have receptive stigmas, the percentage by number of female component plants which have shed pollen, or are shedding pollen, shall not exceed 0.5%;
 - (cc) of Basic Seed the total percentage by number of plants of the female component which are recognisable as obviously not being true to the component and which have shed pollen, or are shedding pollen, shall not exceed 0.5%; and
 - (dd) where a male-sterile component has been used to produce Certified Seed by using a male component which contains a specific restorer line or lines, at least one-third of the plants grown from the resulting hybrid shall produce pollen which appears normal in all aspects.
- (d) in a case where a male-sterile component is used for the production of seed of a hybrid variety of swede rape the percentage by number of male sterility shall be at least 99% for the production of Basic Seed and 98% for the production of Certified Seed and the level of male sterility shall be assessed by examining flowers for the absence of fertile anthers;

- (e) in the case of hybrids of swede rape produced using male sterility the percentage by number of plants which are recognisable as obviously not true to the inbred line or to the component shall not exceed the percentage specified in column 2 of the following table corresponding to the relevant crop specified in column 1 of the table:-

Column 1 Crop of hybrids of swede rape produced using male sterility	Column 2 Percentage by number of plants
(i) For the production of Basic Seed-	
(aa) inbred lines	0.1%
(bb) simple hybrids-	
(bbA) male component	0.1%
(bbB) female component	0.2%
(ii) For the production of Certified Seed-	
(aa) male component	0.3%
(bb) female component	1.0%

Crop conditions for Pre-basic Seed

9. For the purpose of determining whether a crop from which Pre-basic Seed is to be produced meets the conditions specified in this Part of this Schedule, the crop from which such seed is to be produced shall be treated in the same way as a crop from which Basic Seed is to be produced.

PART II

CONDITIONS RELATING TO BASIC SEED, CERTIFIED SEED, CERTIFIED SEED OF THE FIRST GENERATION, CERTIFIED SEED OF THE SECOND GENERATION, CERTIFIED SEED OF THE THIRD GENERATION AND COMMERCIAL SEED

Standards for varietal purity

10. (a) The seed shall possess sufficient varietal identity and varietal purity. In particular, seed of the species and category specified in column 1 of the following table shall possess at least the percentage of minimum varietal purity specified in the corresponding entry in column 2 of the table:-

Column 1 Species and category	Column 2 Percentage of minimum varietal purity
(i) Flax-	
(aa) Basic Seed	99.7%
(bb) Certified Seed of the First Generation	98.0%
(cc) Certified Seed of the Second Generation(a)	97.5%
(dd) Certified Seed of the Third Generation(b)	97.5%
(ii) Linseed-	
(aa) Basic Seed	99.7%
(bb) Certified Seed of the First Generation	98.0%
(cc) Certified Seed of the Second Generation	97.5%
(dd) Certified Seed of the Third Generation	97.5%
(iii) Soya bean-	
(aa) Basic Seed	99.5%

(a) See regulation 3 for the definition of "Certified Seed of the Second Generation".

(b) See regulation 3 for the definition of "Certified Seed of the Third Generation".

Column 1 Species and category	Column 2 Percentage of minimum varietal purity
(bb) Certified Seed of the First Generation	99.0%
(cc) Certified Seed of the Second Generation	99.0%
(iv) Sunflower except hybrid varieties and components of hybrid varieties–	
(aa) Basic Seed	99.7%
(bb) Certified Seed	99.0%
(v) Swede rape (except hybrid varieties) other than varieties to be used solely for fodder purposes and turnip rape other than varieties to be used solely for fodder purposes–	
(aa) Basic Seed	99.9%
(bb) Certified Seed	99.7%
(vi) Swede rape (except hybrid varieties) and turnip rape varieties to be used solely for fodder purposes–	
(aa) Basic Seed	99.7%
(bb) Certified Seed	99.0%
(vii) Hybrid varieties of swede rape produced using male sterility and their components–	
(aa) Basic Seed, female component	99.0%
(bb) Basic Seed, male component	99.9%
(cc) Certified Seed	90.0%
(viii) White mustard–	
(aa) Basic Seed	99.7%
(bb) Certified Seed	99.0%

- (b) Subject to paragraph 11, for the purposes of this paragraph the minimum varietal purity of seed shall be examined mainly in official field inspections carried out in accordance with the conditions specified in Part I of this Schedule.

Standards for varietal purity for hybrid varieties of swede rape

11. In the case of seed of a hybrid variety of swede rape produced using male sterility–

- (a) subject to sub-paragraph (c), the requirement for sufficient varietal identity and varietal purity shall also apply to the characteristics of its components including male sterility or restoration of fertility;
- (b) subject to sub-paragraph (d), the seed shall not be certified as Certified Seed unless due account has been taken of the results of official post-control tests on samples of Basic Seed taken in accordance with regulation 15(1) and carried out during the growing season of the seed for which an application has been made for certification as Certified Seed to ascertain whether the Basic Seed has met the requirements for Basic Seed specified in these Regulations in respect of varietal identity as regards the characteristics of the components, including male sterility and in respect of the minimum varietal purity;
- (c) the varietal purity of a component of the hybrid variety may be assessed by appropriate biochemical methods; and
- (d) the standards in respect of the minimum varietal purity laid down in sub-paragraph (b) in respect of Certified Seed of hybrids shall be monitored by official post-control tests on an appropriate proportion of samples taken in accordance with regulation 15(1) and appropriate biochemical methods may be used in these official post-control tests.

Parental ratio in production of Certified Seed of hybrids of sunflower

12. Where a female male-sterile component and a male component which does not restore male fertility have been used for the production of Certified Seed of hybrids of sunflower, the seed produced by the male-sterile parent shall be blended with seed produced by the fully fertile parent. The ratio of male-sterile parent seed to male-fertile parent seed shall not exceed two to one.

Further standards and conditions of varietal purity

13. The seed shall, subject to paragraph 14, comply with the following standards and other conditions as regards percentage germination of pure seed, analytical purity and content of seed of other plant species (including *Orobanch* spp.):—

Species	Minimum germination (% of pure seed)	Analytical purity		Maximum content by number of seeds of other plant species in a sample of the weight specified in column 4 of the table in paragraph 24 of Part II of Schedule 5						
		Minimum analytical purity (% by weight)	Maximum content of seed of other plant species (% by weight)	Other plant species (including seed of the species specified in columns 6 to 11)	Wild Oat (<i>Avena fatua</i> , <i>A. ludoviciana</i> , <i>A. sterilis</i>)	Dodder (<i>Cuscuta</i> spp.)	Wild radish (<i>Raphanus raphanistrum</i>)	Dock (<i>Rumex</i> spp. excluding <i>R. acetosella</i>)	Blackgrass (<i>Alopecurus myosuroides</i>)	<i>Lolium remotum</i>
1	2	3	4	5	6	7	8	9	10	11
Black mustard and brown mustard										
– Basic Seed	85	98	0.3	n/a	0	0	10	2	n/a	n/a
– Certified Seed	85	98	0.3	n/a	0	0	10	5	n/a	n/a
Flax	92	99	n/a	15	0	0	n/a	n/a	4	2
Hemp	75	98	n/a	30	0	0	n/a	n/a	n/a	n/a
Linseed	85	99	n/a	15	0	0	n/a	n/a	4	2
Soya bean	80	98	n/a	5	0	0	n/a	n/a	n/a	n/a
Sunflower	85	98	n/a	5	0	0	n/a	n/a	n/a	n/a
Swede rape and turnip rape										
– Basic Seed	85	98	0.3	n/a	0	0	10	2	n/a	n/a
– Certified Seed	85	98	0.3	n/a	0	0	10	5	n/a	n/a
White mustard										
– Basic Seed	85	98	0.3	n/a	0	0	10	2	n/a	n/a
– Certified Seed	85	98	0.3	n/a	0	0	10	5	n/a	n/a

Further provisions relating to varietal purity

14. (a) The presence of one seed of dodder (*Cuscuta* spp.) in a sample of–
- (i) black mustard;
 - (ii) brown mustard;
 - (iii) flax;
 - (iv) linseed;
 - (v) swede rape;
 - (vi) turnip rape; or
 - (vii) white mustard,
- shall not be regarded as an impurity where a second sample of the same weight is free from any seeds of dodder.
- (b) The determination of total content of seed of other plant species by number need not be carried out in the case of hemp seed unless there is doubt whether the conditions laid down in column 5 of the table in paragraph 13 have been satisfied.
- (c) Subject to sub-paragraph (d), hemp seed shall be free from *Orobanche* spp..
- (d) The presence of one seed of *Orobanche* spp. in a sample of 100 grams of hemp seed shall not be regarded as an impurity where a second sample of 200 grams is free from any seed of *Orobanche* spp..

Harmful organisms in the seed

15. (a) Harmful organisms which reduce the usefulness of the seed shall be at the lowest possible level.
- (b) Subject to sub-paragraph (c) in any sample of seed of the species specified in column 1 of the following table:–
- (i) harmful organisms of the type specified in columns 2 and 3 of the table shall not exceed the percentage by number of seeds specified in the relevant corresponding entry of the table; and
 - (ii) the number of sclerotia or fragments of sclerotia in a sample of the weight specified in column 4 of the table specified in paragraph 24 of Part II of Schedule 5 shall not exceed the number specified in the relevant corresponding entry in column 4 of the following table:–

Species	Harmful organisms		
	Maximum percentage by number of seeds contaminated by harmful organisms (total per column)		<i>Sclerotinia sclerotiorum</i> (maximum number of sclerotia or fragments of sclerotia in a sample of the weight specified in Column 4 of paragraph 24 of Part II of Schedule 5)
	<i>Botrytis</i> spp.	<i>Alternaria</i> spp., <i>Ascochyta linicola</i> (syn. <i>Phoma linicola</i>), <i>Colletotrichum lini</i> , <i>Fusarium</i> spp.	
1	2	3	4
Flax	5	5	n/a
Hemp	5	n/a	n/a
Linseed	5	5	n/a
Sunflower	5	n/a	10
Swede rape	n/a	n/a	10

Species	Harmful organisms		
	Maximum percentage by number of seeds contaminated by harmful organisms (total per column)		<i>Sclerotinia sclerotiorum</i> (maximum number of sclerotia or fragments of sclerotia in a sample of the weight specified in Column 4 of paragraph 24 of Part II of Schedule 5)
	<i>Botrytis</i> spp.	<i>Alternaria</i> spp., <i>Ascochyta linicola</i> (syn. <i>Phoma linicola</i>), <i>Colletotrichum lini</i> , <i>Fusarium</i> spp.	
1	2	3	4
Turnip rape	n/a	n/a	5
White mustard	n/a	n/a	5

- (c) Notwithstanding the provisions of sub-paragraph (b), in any sample of flax seed, the maximum percentage by number of seed of *Ascochyta linicola* (syn. *Phoma linicola*) shall not exceed 1%.
- (d) In the case of soya bean seed—
- (i) within a sample of at least 5,000 seeds per seed lot which is subdivided into 5 sub-samples, the maximum number of sub-samples which are found to be contaminated by *Pseudomonas syringae* pv. *glycinea* shall not exceed 4;
 - (ii) where suspect colonies are identified in all five sub-samples referred to in sub-paragraph (i) appropriate biochemical tests on the suspect colonies isolated on a preferential medium for each sub-sample may be used to confirm the conditions specified in sub-paragraph (i);
 - (iii) the maximum number of seeds contaminated by *Diaporthe phaseolorum* shall not exceed 15%; and
 - (iv) the percentage by weight of inert matter shall not exceed 0.3%.

PART III

OFFICIAL EXAMINATIONS USED TO ASCERTAIN WHETHER A CROP OR SEED LOT MEETS THE CONDITIONS RELATING TO BASIC SEED, CERTIFIED SEED, CERTIFIED SEED OF THE FIRST GENERATION, CERTIFIED SEED OF THE SECOND GENERATION, CERTIFIED SEED OF THE THIRD GENERATION AND COMMERCIAL SEED

Methods for official examinations

16. All official examinations used to ascertain whether crops or seed lots meet the standards specified in this Schedule shall be carried out in accordance with current international methods.

SCHEDULE 5

Regulations 2(1), 15(1) and (2),
23(5) and (6) and paragraph 15
of Part II of Schedule 4

PART I

SAMPLING OF SEED LOTS

Definitions

1. In this Part of this Schedule—

“composite sample” means a single sample comprising all of the primary samples taken from a seed lot during a single sampling exercise to produce a submitted sample(a) for the seed lot; and

“primary sample” means a sample taken from a seed lot in accordance with paragraphs 13 to 18 of this Part of this Schedule.

Obtaining a submitted sample

2. A submitted sample shall be obtained from the seed lot by taking primary samples systematically or at random from different positions in the seed lot and combining them to form a composite sample. Where the composite sample is a submitted sample, it may be submitted for an official examination intact or it may be reduced in weight by using one of the instruments referred to in paragraph 19 of this Part of this Schedule in accordance, where appropriate, with the relevant procedures specified in paragraphs 19 to 21 of this Part of this Schedule to give a smaller submitted sample.

Primary sample size

3. At each position of sampling of a seed lot, primary samples of approximately equal size shall be taken.

Condition of the seed lot

4. The seed lot to be sampled shall be a homogeneous seed lot(b).

Seed lot containers

5. If a seed lot is presented for sampling in more than one container, the containers shall be of the same size and type and contain approximately the same weight of seed.

Sampling from sacks - minimum number of containers to be sampled

6. When the seed lot is in sacks or similar sized containers each containing at least 15 kilograms of seed and not more than 100 kilograms of seed, the minimum number of containers to be sampled shall be in accordance with the following table:—

(a) See regulation 2(1) for the definition of “submitted sample”.

(b) See regulation 2(1) for the definition of “homogeneous seed lot”.

Number of containers in which the seed lot is contained	Minimum number of containers to be sampled
1-4	3 primary samples from each container
5-8	2 primary samples from each container
9-15	1 primary sample from each container
16-30	A total of 15 primary samples with each sample being taken from a different container
31-59	A total of 20 primary samples with each sample being taken from a different container
60 or more	A total of 30 primary samples with each sample being taken from a different container

Sampling from sacks or similar containers

7. The containers to be sampled shall be selected systematically or at random and primary samples shall be drawn from the top, middle and bottom of containers; and if more than one primary sample is taken from any container then the position from which the seed is taken shall be varied from primary sample to primary sample and from container to container.

Sampling from small containers - general

8. For sampling seed lots in containers holding less than 15 kilograms of seed, a 100 kilogram weight of seed shall be taken as the basic unit and the small containers shall be combined to form sampling units not exceeding this weight (for example 9 packages of 10 kilograms, 20 packages of 5 kilograms) and for sampling purposes each unit shall be regarded as one container and the sampling procedures prescribed in paragraphs 6 and 7 of this Part of this Schedule shall be used.

Sampling from small containers - moisture-proof containers

9. When seed is in moisture-proof containers the opened or pierced containers shall be adequately closed or the residues from sampling transferred to new containers.

Sampling from small containers - primary samples

10. When seed is in packets of 100 grams or less each packet may be considered as a primary sample and sufficient shall be taken at random to obtain a submitted sample.

Sampling from large containers

11. For the sampling of containers holding at least 100 kilograms of seed, primary samples shall be taken from different horizontal and vertical positions selected at random and the minimum number of primary samples to be taken shall be in accordance with the following table:-

Seed lot weight (kilograms)	Number of primary samples to be taken
Up to 500	At least 5
501-3,000	1 for each 300 kilograms but no fewer than 5
3,001-20,000	1 for each 500 kilograms but no fewer than 10
20,001 and above	1 for each 700 kilograms but no fewer than 40

Sampling from a seed stream

12. Primary samples may be drawn from a seed stream during processing using an automatic sampling device, which shall uniformly sample the entire cross-section of the seed stream when a sample is taken. Primary samples of seed shall be taken at regular intervals throughout the processing of the seed lot using the same sampling intensity as specified in paragraph 11 of this Part of this Schedule.

Sampling instruments - general

13. Sampling instruments shall be capable of sampling all parts of the seed lot.

Sampling instruments - instruments and methods

14. Subject to paragraph 15 of this Part of this Schedule, one of the instruments described in paragraph 16 of this Part of this Schedule shall be used, as appropriate to the location of the seed, to draw primary samples in accordance with the relevant methods described in paragraphs 17 and 18 of this Part of this Schedule.

Sampling instruments - power to allow other instruments and methods

15. Where it is not practicable to use any of the instruments described in paragraph 16 of this Part of this Schedule in accordance with the relevant methods described in paragraphs 17 and 18 of this Part of this Schedule, another instrument or method may be used with the written approval of the Scottish Ministers.

Sampling instruments - instruments for drawing primary samples

16. The instruments referred to in paragraph 14 of this Part of this Schedule, to be used for drawing primary samples are as follows:-

(a) **Dynamic spear sampler**

Subject to paragraph 13 of this Part of this Schedule, a dynamic spear sampler may be used, in accordance with the methods described in paragraph 18(a) of this Part of this Schedule, for sampling seed lots in sacks or small containers. It shall be a hollow, cylindrical, solid-pointed metal spear or trier which shall be long enough to reach beyond the middle of the sack from the side and shall have an aperture so positioned that portions of seed of equal volume are removed from each part of the sack through which it travels. In sampling seed lots of the species specified in column 1 of the following table a dynamic spear sampler shall have a point length (a), shoulder length (b), boss length (c), aperture length (d), aperture width (e), bore width (f) and outside diameter (g) as shown in the diagrams below of dimensions no smaller than those specified in the corresponding entries in the table:-

Species of Seed for which dynamic spear sampler can be used	Dimensions in millimetres						
	Point length (a)	Shoulder length (b)	Boss length (c)	Aperture Length (d)	Aperture Width (e)	Bore width (f)	Outside Diameter (g)
1	2	3	4	5	6	7	8
All species other than flax, hemp, linseed, soya bean or sunflower	42	7	8	20	8	10	12
Flax and linseed	85	12	10	33	11	13	15

Species of Seed for which dynamic spear sampler can be used	Dimensions in millimetres						
	Point length (a)	Shoulder length (b)	Boss length (c)	Aperture Length (d)	Aperture Width (e)	Bore width (f)	Outside Diameter (g)
1	2	3	4	5	6	7	8
Hemp, soya bean and sunflower	82	12	13	40	15	17	19

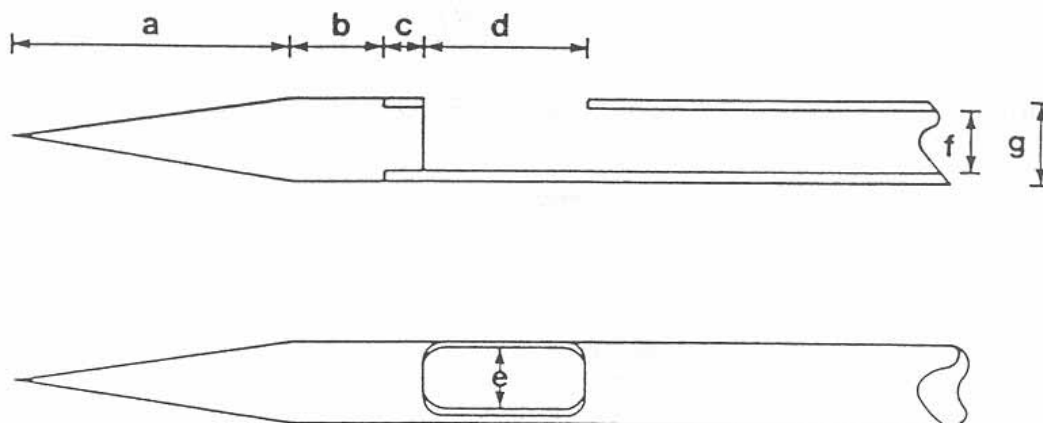

(b) Stick samplers

A stick sampler of one of the types described in sub-paragraphs (i) and (ii) may, subject to sub-paragraphs (i) and (ii), be used if it has an aperture or apertures of sufficient size to allow the unrestricted entry of seed and other particles and is capable of being opened and closed during the sampling procedure as appropriate to the method of use described in paragraph 18(b) and (c) of this Part of this Schedule.

(i) Single chamber type

Subject to paragraph 13 of this Part of this Schedule, a single chamber type stick sampler may be used to sample seed lots in open sacks or in large containers. In sampling seed lots in open sacks or in large containers, as specified in column 1 of the following table, a single chamber type stick sampler shall have a point length (a), shoulder length (b), sliding sleeve length (c), aperture length (d), aperture width (e) and bore width (f), as shown in the diagrams below, of the dimensions specified in the corresponding entries in the table, or such other dimensions as the Scottish Ministers may approve in writing:-

Type of Container	Dimensions in millimetres					
	Point length (a)	Shoulder length (b)	Sliding sleeve length (c)	Aperture length (d)	Aperture width (e)	Bore width (f)
1	2	3	4	5	6	7
Seed lots in sacks	55	25	75	50	22	25
Seed lots in large containers or seed in bulk	100	390	63	50	22	30

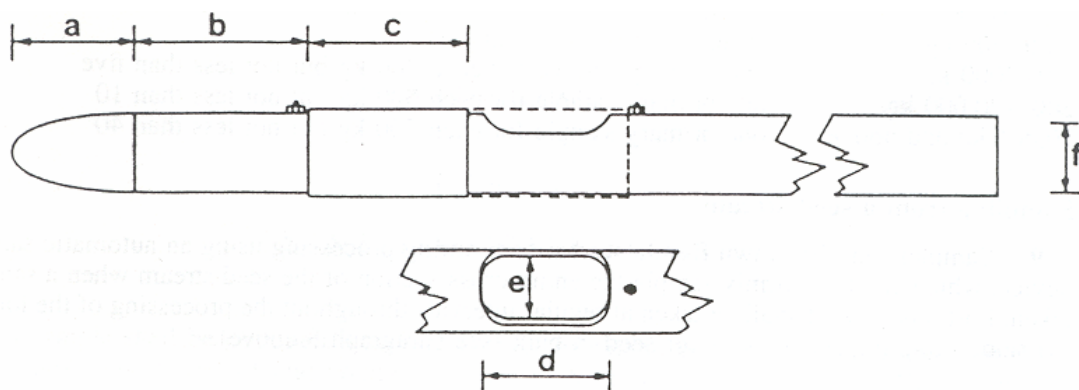

(ii) Multi-chamber type

Subject to paragraph 13 of this Part of this Schedule, a multi-chamber type stick sampler may be used to sample seed lots in sacks or any other containers. The apertures shall open into chambers which shall be separated from one another by transverse partitions. The contents of each chamber shall be regarded as a primary sample. The multi-chamber type stick sampler shall have a point length (a), shoulder length (b), aperture length (c), aperture width (d), aperture separation distance (e) and bore width (f), as shown in the diagram below, of the dimensions specified in the following table or such other dimensions as the Scottish Ministers may approve in writing:-

Dimensions in millimetres					
Point length (a)	Shoulder length (b)	Aperture length (c)	Aperture width (d)	Aperture separation distance (e)	Bore width (f)
60	50	100	15	110	25

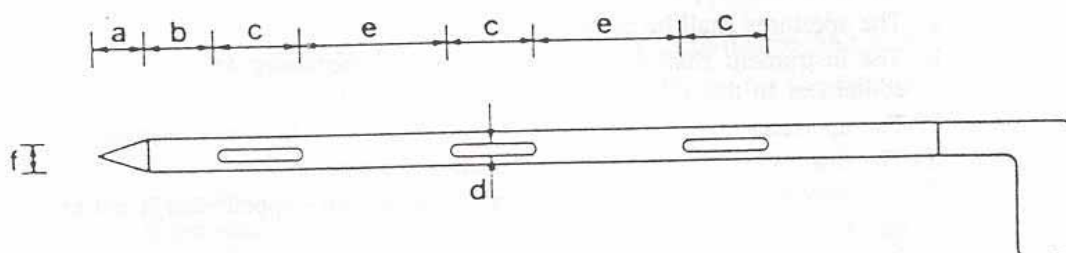

(c) Cargo sampler

Subject to paragraph 13 of this Part of this Schedule, a cargo sampler may be used, in accordance with the method described in paragraph 18(d) of this Part of this Schedule, to sample seed lots in large containers and shall only be used in the vertical position.

(d) **Seed stream sampler**

Subject to paragraph 13 of this Part of this Schedule, a seed stream sampler may be used if it has been approved in writing by the Scottish Ministers and if it uniformly samples the cross-section of the seed stream without any loss of the seed and any other particles which enter the seed stream sampler, in accordance with the method described in paragraph 18(e) of this Part of this Schedule. Timing devices shall be attached so that the frequency and duration of sampling can be adjusted to meet the requirements of paragraph 12 of this Part of this Schedule.

Methods of use of dynamic spear samplers, stick samplers, cargo samplers and seed stream samplers - general

17. All instruments shall be clean before use.

Methods of use of dynamic spear samplers, stick samplers, cargo samplers and seed stream samplers - specific

18. The methods of using the instruments described in paragraph 16 shall be as follows:–

Dynamic spear sampler

(a) Dynamic spear samplers may be used in one of two ways depending on their length–

Method 1

(i) in the case of a dynamic spear sampler in which the aperture reaches only to the centre of the sack or small container–

- (aa) the instrument shall be inserted into the sack in an upward direction at an angle of approximately 30° to the horizontal with its aperture downwards until the aperture reaches the centre of the sack or container;
- (bb) the instrument shall be lightly tapped to remove any seed taken in and then rotated to bring the aperture uppermost;
- (cc) the instrument shall be withdrawn immediately with a vibratory or oscillatory motion and at a decreasing speed so that the quantity of seed and any other particles obtained from successive locations increases progressively from the centre to the side of the sack; and
- (dd) seed and any other particles passing through the instrument shall be collected in a clean container.

Method 2

(ii) in the case of a dynamic spear sampler in which the aperture reaches to the far side of a sack or small container–

- (aa) the instrument shall be inserted in the manner described in sub-paragraph (i)(aa) until its aperture reaches almost to the far side of the sack or container;
- (bb) the instrument shall be tapped and rotated in the manner described in sub-paragraph (i)(bb) and then withdrawn at a uniform speed; and
- (cc) the seed and any other particles passing through the instrument shall be collected in a clean container.

Stick samplers

Single chamber type stick sampler

(b) In the case of a single chamber type stick sampler–

- (i) the sleeve shall move freely;

- (ii) the instrument shall be inserted vertically downwards until the aperture reaches the appropriate primary sampling position ensuring that the sleeve covers the aperture as it enters the seed lot;
- (iii) the instrument shall be withdrawn sufficiently to uncover the aperture;
- (iv) the instrument shall be left in position until the primary sample has been collected; and
- (v) the instrument shall be withdrawn and the contents emptied into a clean container.

Multi-chamber type stick sampler

- (c) In the case of a multi-chamber type stick sampler–
 - (i) the apertures shall be closed before insertion;
 - (ii) the instrument shall be inserted diagonally into sacks or vertically into large containers so that all apertures are fully covered;
 - (iii) the apertures shall be opened;
 - (iv) the instrument shall be agitated so that seed and any other particles enter the chambers;
 - (v) the apertures shall be closed gently to ensure that trapped seed and any other particles are not broken or damaged;
 - (vi) the instrument shall be withdrawn and if the chambers are full the contents shall be emptied onto a clean surface or into a clean container; and
 - (vii) if all the chambers are not full, the contents shall be discarded and the procedures specified in sub-paragraphs (c)(i) to (vi) shall be repeated.

Cargo sampler

- (d) In the case of cargo sampler–
 - (i) the lid shall open and close easily;
 - (ii) the instrument shall be inserted with the lid closed to the appropriate primary sampling position which shall be at least 300 millimetres below the surface of the seed lot;
 - (iii) the handle shall be raised sufficiently to open the lid;
 - (iv) the instrument shall be left in position until the primary sample has been collected; and
 - (v) the instrument shall be withdrawn and the contents shall be emptied into a clean container.

Seed stream sampler

- (e) In the case of a seed stream sampler, the instrument shall take the number of primary samples necessary for the weight of seed lot being sampled, the primary samples being taken from the seed lot at regular intervals and the resultant composite sample being of a weight not less than the minimum weight prescribed in paragraph 24 of Part II of this Schedule and not greater than can conveniently be reduced by means of one of the methods of sample reduction specified in paragraphs 19 to 21. They shall be installed in such a way that the composite sample can be readily identified with the seed lot from which it was taken.

Obtaining a submitted sample - composite sample division instruments

19. Where the composite sample exceeds the minimum weight prescribed for a sample in paragraph 24 of Part II of this Schedule, any of the following instruments may be used to reduce the weight of the sample:–

Riffle divider

- (a) (i) The riffle divider shall consist of a rectangular hopper leading to a series of evenly spaced chutes, arranged so that seed is distributed equally on two sides;
- (ii) there shall be a minimum of 18 chutes, each discharging in the opposite direction to its immediate neighbour; and
- (iii) three (or more) metal collecting vessels (pans) of sufficient depth to prevent seed bouncing out shall be used.

Centrifugal divider

- (b) (i) The centrifugal divider shall consist of a hopper from which seed flows on to a shallow cup which is then rotated by an electric motor; and
- (ii) the seed shall be distributed by centrifugal force onto a stationary baffle which divides it into two equal parts which are then discharged through separate spouts. Four metal collecting vessels (pans) of sufficient depth to prevent seed bouncing out shall be used.

Other instruments

- (c) Other instruments and methods may be used with the written approval of the Scottish Ministers.

Method of use of riffle divider

20. The method of using a riffle divider shall be as follows:–

- (a) the riffle divider shall be placed on a firm level surface;
- (b) the riffle divider and pans shall be clean;

Sample mixing

- (c) an empty pan shall be placed on each side of the riffle divider to receive the discharge from the chutes;
- (d) the entire composite sample shall be poured evenly into the other pan(s);
- (e) the seed shall then be poured from the pan(s) evenly along the entire length of the hopper;
- (f) the two pans into which the seed has passed shall then be replaced with empty pans;
- (g) the procedures specified in sub-paragraphs (e) and (f) shall then be repeated twice to mix the sample thoroughly;

Sample reduction

- (h) before reduction, the composite sample shall have been thoroughly mixed using the procedures specified in sub-paragraphs (c) to (g). The contents of one of the two receiving pans shall then be set aside. If the seed and any other particles in the second pan is of at least the minimum weight prescribed in paragraph 24 of Part II of this Schedule for a sample, it may be used as a submitted sample. If the weight of seed in the second pan is greater than the minimum weight prescribed in paragraph 24 of Part II of this Schedule for a sample, it may be reduced using the procedures specified in sub-paragraphs (i) to (k);
- (i) an empty pan shall be placed on each side of the divider to receive the discharge from the chutes;
- (j) the contents of the second pan shall be poured evenly along the entire length of the hopper;
- (k) the contents of one of the two pans into which the seed and other particles have passed shall then be set aside. If the weight of seed and other particles in the other pan is still greater than the minimum weight prescribed in paragraph 24 of Part II of this Schedule

for a sample, it may be used as a submitted sample intact or it may be reduced further using the procedures specified in sub-paragraphs (i) to (k);

- (l) if the weight of seed and other particles in either of the two pans set aside in the procedures specified either in sub-paragraph (h) or sub-paragraph (k) is less than the minimum weight prescribed in paragraph 24 of Part II of this Schedule for a sample, the procedures specified in sub-paragraphs (m) to (q) shall be used;
- (m) an empty pan shall be placed on each side of the divider to receive the discharge from the chutes;
- (n) the contents of one of the pans shall be set aside. The contents of the other pan shall be poured evenly along the entire length of the hopper;
- (o) one receiving pan and its contents shall then be removed and replaced with an empty pan. The other pan, with its contents, shall be left in place;
- (p) the contents of the pan removed during the procedure specified in sub-paragraph (o) shall be poured evenly along the entire length of the hopper so that two sub-samples of different weights shall be produced;
- (q) the procedures specified in sub-paragraphs (o) and (p), when repeated, constitute the process of continuous halving, and shall be repeated using whichever sub-sample is appropriate until sufficient seed and any other particles is obtained in one pan, which, when added to the seed and any other particles set aside during the procedure specified in sub-paragraph (n), produces a submitted sample;

Obtaining more than one submitted sample

- (r) when two submitted samples are required from one composite sample, one composite sample of at least twice the minimum weight prescribed in paragraph 24 of Part II of this Schedule for a sample shall be obtained using the procedures specified in sub-paragraphs (c) to (g) and (h) to (q), as appropriate. The composite sample shall then be divided into two parts by passing it once through the riffle divider; and
- (s) when three submitted samples are required from one composite sample, one composite sample of at least three times the minimum weight prescribed in paragraph 24 of Part II of this Schedule for a sample shall be obtained using the procedures specified in sub-paragraphs (c) to (g) and (h) to (q) as appropriate. A submitted sample shall then be extracted using the procedures specified in sub-paragraphs (c) to (g) and (h) to (q), as appropriate. All portions of seed which have been set aside shall then be recombined and two submitted samples shall be obtained from this residue of the composite sample by following the procedure specified in sub-paragraph (r).

Methods of use of a centrifugal divider

21. The method of using a centrifugal divider shall be as follows:–

- (a) the centrifugal divider shall be levelled prior to use;
- (b) the centrifugal divider and pans shall be clean;

Sample mixing

- (c) an empty pan shall be placed under each spout of the centrifugal divider;
- (d) the entire composite sample shall be poured into the centre of the hopper;
- (e) the motor shall be operated so that the seed and any other particles in the sample pass into the pans;
- (f) the motor shall be switched off;
- (g) the two pans containing seed and any other particles shall be removed and replaced by empty ones;
- (h) the contents of both pans removed during the procedure specified in sub-paragraph (g) shall be poured together into the centre of the hopper, the seed and any other particles

being allowed to blend as they flow in. The procedures specified in sub-paragraphs (e) to (g) shall be repeated;

- (i) the procedure specified in sub-paragraph (h) shall be repeated to mix the sample thoroughly;

Sample reduction

- (j) before reduction, the composite sample shall have been thoroughly mixed using the procedures specified in sub-paragraphs (c) to (i). The contents of one of the two receiving pans shall then be set aside. If the seed and any other particles in the second pan is of at least the minimum weight prescribed in paragraph 24 of Part II of this Schedule for a sample, it may be used as a submitted sample. If the weight of seed in the second pan is greater than the minimum weight prescribed in paragraph 24 of Part II of this Schedule for a sample, it may be reduced using the procedures specified in sub-paragraphs (k) to (m);
- (k) empty pans shall be placed under the spouts;
- (l) the contents of the second pan shall be poured into the hopper and the procedures specified in sub-paragraphs (e) and (f) shall be repeated;
- (m) the contents of one of the two pans into which the seed and any other particles have passed shall then be set aside. If the weight of seed and any other particles in the other pan is still greater than the minimum weight prescribed in paragraph 24 of Part II of this Schedule for a sample, the sample may be used as a submitted sample intact or it may be reduced further using the procedures specified in sub-paragraphs (k) to (m);
- (n) if the weight of seed and any other particles in either of the two pans referred to either in sub-paragraph (j) or (m) is less than the minimum weight prescribed in paragraph 24 of Part II of this Schedule for a sample, the procedures specified in sub-paragraphs (o) to (s) shall be used;
- (o) empty pans shall be placed under the spouts;
- (p) the contents of one of the pans shall be set aside. The contents of the other pan shall be poured into the centre of the hopper and the procedures specified in sub-paragraphs (e) and (f) shall be repeated;
- (q) one receiving pan and its contents shall then be removed and replaced with an empty pan. The other pan, with its contents, shall be left in place;
- (r) the contents of the pan removed during the procedure specified in sub-paragraph (q) shall be poured into the centre of the hopper and the procedures specified in sub-paragraphs (e) and (f) shall be repeated so that two sub-samples of different weights shall be produced;
- (s) the procedures specified in sub-paragraphs (q) and (r), when repeated, constitute the process of continuous halving, and shall be repeated using whichever sub-sample is appropriate until a sufficient sample is obtained in one pan, which, when added to the seed and any other particles set aside during the procedure specified in sub-paragraph (p), produces a submitted sample;

Obtaining more than one submitted sample

- (t) when two submitted samples are required from one composite sample, one composite sample of at least twice the minimum weight prescribed in paragraph 24 of Part II of this Schedule for a sample shall be obtained using the procedures specified in sub-paragraphs (c) to (i) and (j) to (s) as appropriate. The composite sample shall then be divided into two parts by passing it once through the centrifugal divider; and
- (u) when three submitted samples are required from one composite sample, one composite sample of at least three times the minimum weight prescribed in paragraph 24 of Part II of this Schedule for a sample shall be obtained using the procedures specified in sub-paragraphs (c) to (i) and (j) to (s), as appropriate. A submitted sample shall then be extracted using the procedures specified in sub-paragraphs (c) to (i) and (j) to (s), as appropriate. All portions of seed which have been set aside shall then be recombined and

two submitted samples shall be obtained from this residue of the composite sample by following the procedure specified in sub-paragraph (t).

PART II

MAXIMUM WEIGHT OF A SEED LOT AND MINIMUM WEIGHT OF A SUBMITTED SAMPLE

Maximum weight of a seed lot

22. Subject to paragraph 23, the maximum weight of a seed lot shall be that set out in column 2 of the table in paragraph 24 in relation to the corresponding entry in column 1 of the table.

Margin by which seed lots can exceed maximum weight

23. A seed lot may exceed the maximum weight for a seed lot set out in column 2 of the table in paragraph 24 by not more than 5%.

Minimum weight of a sample

24. The minimum weight of a sample submitted for official examination shall be that specified in column 3 of the following table in relation to the corresponding entry in column 1 of the table:–

Column 1	Column 2	Column 3	Column 4
Species	Maximum weight of a seed lot	Minimum weight of a sample taken from a seed lot for submission for official examination	Weight of the sample for determination by number provided for in columns 5 to 11 of the table in paragraph 13 of Part II of Schedule 4, and column 4 of the table in paragraph 15 of Part II of Schedule 4
	tonnes	grams	grams
Black mustard	10	100	40
Brown mustard	10	100	40
Flax	10	300	150
Hemp	10	600	600
Linseed	10	300	150
Soya bean	25	1,000	1,000
Sunflower	25	1,000	1,000
Swede rape	10	200	100
Turnip rape	10	200	70
White mustard	10	400	200

SCHEDULE 6 Regulation 6(5), 17(4), (5), (8), (10),
(11), 18, 21(3), (5), (6) and (11)

PART I
GENERAL

Method of referring to species of seed

1. Where the species of seed is one of the particulars to be indicated on a label, in accordance with the provisions of this Schedule, the species must be indicated at least under its botanical name, which may be given in abridged form and without the author's name, in Roman characters.

Method of referring to varieties of seed

2. Where the variety of seed is one of the particulars to be indicated on a label, in accordance with the provisions of this Schedule, the variety must be indicated at least in Roman characters.

PART II
LABELS

Label for a package of Breeder's Seed

3. The label for a package of Breeder's Seed shall—

- (a) contain the following information:—
 - (i) name and address of the supplier responsible for affixing the labels or the supplier's registered number;
 - (ii) reference number of the seed lot;
 - (iii) species;
 - (iv) variety;
 - (v) the words "Breeder's Seed";
 - (vi) declared net or gross weight; and
 - (vii) the words "NOT CERTIFIED"; and
- (b) be coloured buff.

Official label for a package of Pre-basic Seed

4. The official label for a package of Pre-basic Seed shall—

- (a) contain the following information:—
 - (i) certifying authority and EEA State or their commonly used initials;
 - (ii) month and year of sealing or the month and year of the last official sampling for the purposes of certification, expressed respectively as follows:—
 - (aa) by the word "Sealed" followed by the month and year of sealing; or
 - (bb) by the word "Sampled" followed by the month and year of official sampling;
 - (iii) reference number of the seed lot;
 - (iv) species;

- (v) variety;
 - (vi) the words “Pre-basic Seed”;
 - (vii) country of production;
 - (viii) declared net or gross weight;
 - (ix) where weight is indicated and granulated pesticides, pelleting substances or other solid additives are used, the nature of the additives and also the approximate ratio between the weight of seed and the total weight; and
 - (x) number of generations preceding seed of the categories Certified Seed or Certified Seed of the First Generation;
- (b) be a minimum size of 110 millimetres by 67 millimetres; and
- (c) be coloured white with a diagonal violet line.

Official label for a package of Basic Seed or Seed of a Certified Generation

5. The official label for a package of Basic Seed or Seed of a Certified Generation shall—

- (a) subject to sub-paragraph (b), contain the following information:—
 - (i) the words “EC rules and standards”;
 - (ii) certifying authority and EEA State or their commonly used initials;
 - (iii) month and year of sealing or the month and year of the last official sampling for the purposes of certification, expressed respectively as follows:—
 - (aa) by the word “Sealed” followed by the month and year of sealing; or
 - (bb) by the word “Sampled” followed by the month and year of official sampling;
 - (iv) reference number of the seed lot;
 - (v) species;
 - (vi) variety;
 - (vii) category;
 - (viii) country of production;
 - (ix) declared net or gross weight;
 - (x) where weight is indicated and granulated pesticides, pelleting substances or other solid additives are used, the nature of the additive and also the approximate ratio between the weight of pure seed and the total weight;
 - (xi) in the case of Basic Seed which is a component of a hybrid variety, where the component has been officially accepted on to a UK National List or the Common Catalogue, the name under which it has been officially accepted, with or without reference to the final hybrid variety, accompanied, in the case of a component which is intended solely as a component for a final hybrid variety, by the word “component”;
 - (xii) in the case of Basic Seed which is a component of a hybrid variety where the component has not been officially accepted on to a UK National List or the Common Catalogue, the name of the component, which may be given in code form, accompanied by a reference to the final hybrid variety, with or without reference to its function (male or female), and accompanied by the word “component”;
 - (xiii) in the case of Seed of a Certified Generation which is a hybrid, the name of the variety to which the seed belongs, accompanied by the word “hybrid”;
 - (xiv) in the case of Certified Seed which is intended to be used as a component of a varietal association of swede rape, a reference to its function (male or female), accompanied by the word “component” and the name of the final varietal association; and

- (xv) where at least germination has been retested, the word “Retested” followed by the month and year of retesting and the service responsible for such retesting;
- (b) not contain the information referred to in sub-paragraph (a)(xv) if that information is given on an official sticker attached to the official label;
- (c) be a minimum size of 110 millimetres by 67 millimetres; and
- (d) be coloured–
 - (i) white for Basic Seed;
 - (ii) blue for Certified Seed and Certified Seed of the First Generation; and
 - (iii) red for Certified Seed of the Second Generation and Certified Seed of the Third Generation.

Official label for a package of Commercial Seed

6. The official label for a package of Commercial Seed shall–

- (a) subject to sub-paragraph (b), contain the following information:–
 - (i) the words “EC rules and standards”;
 - (ii) certification authority and EEA State or their commonly used initials;
 - (iii) month and year of sealing expressed by the word “Sealed” followed by the month and year of sealing;
 - (iv) reference number of the seed lot;
 - (v) species;
 - (vi) the words “Commercial Seed (not certified as to variety)”;
 - (vii) country of production and the region of production within that country;
 - (viii) declared net or gross weight;
 - (ix) where weight is indicated and granulated pesticides, pelleting substances or other solid additives are used, the nature of the additive and also the approximate ratio between the weight of pure seed and the total weight; and
 - (x) where at least germination has been retested, the word “Retested” followed by the month and year of retesting and the service responsible for such retesting;
- (b) not contain the information referred to in sub-paragraph (a)(x) if that information is given on an official sticker attached to the official label;
- (c) be a minimum size of 110 millimetres by 67 millimetres; and
- (d) be coloured brown.

Official label for a package of a varietal association of seed

7. The official label for a package of a varietal association of seed shall–

- (a) subject to sub-paragraph (b), contain the following information:–
 - (i) the words “EC rules and standards”;
 - (ii) certifying authority and EEA State or their commonly used initials;
 - (iii) month and year of sealing or the month and year of the last official sampling for the purposes of certification, expressed respectively as follows:–
 - (aa) by the word “Sealed” followed by the month and year of sealing; or
 - (bb) by the word “Sampled” followed by the month and year of official sampling;
 - (iv) reference number of the seed lot;
 - (v) species;
 - (vi) the words “varietal association” followed by its name;

- (vii) category;
- (viii) country of production;
- (ix) declared net or gross weight;
- (x) where weight is indicated and granulated pesticides, pelleting substances or other solid additives are used, the nature of the additive and also the approximate ratio between the weight of pure seed and the total weight;
- (xi) the percentages by weight of the various components in the varietal association shown by variety unless this information has been notified to the purchaser on request and notified to a National Authority; and
- (xii) where at least the germination of the components of the varietal association have been retested, the word "Retested" followed by the month and year of retesting and the service responsible for such retesting;
- (b) not contain the information referred to in sub-paragraph (a)(xii) if that information is given on an official sticker attached to the official label;
- (c) be a minimum size of 110 millimetres by 67 millimetres; and
- (d) be coloured blue with a diagonal green line.

PART III

SMALL PACKAGES

Label for a small package of Pre-basic Seed, Basic Seed, Seed of a Certified Generation or Commercial Seed

8. The label for a small package of Pre-basic Seed, Basic Seed, Seed of a Certified Generation or Commercial Seed shall—

- (a) contain the following information:—
 - (i) the words "EC rules and standards";
 - (ii) name and address of the person responsible for fixing the label;
 - (iii) reference number of the seed lot;
 - (iv) species;
 - (v) variety (or, in the case of Commercial Seed the words "Commercial Seed not certified as to variety");
 - (vi) category; and
 - (vii) declared net weight, except in the case of packages not exceeding 15 grams net weight; and
- (b) be coloured—
 - (i) white with a diagonal violet line for Pre-basic Seed;
 - (ii) white for Basic Seed;
 - (iii) blue for Certified Seed and Certified Seed of the First Generation;
 - (iv) red for Certified Seed of the Second Generation and Certified Seed of the Third Generation; and
 - (v) brown for Commercial Seed.

PART IV
PARTICULARS TO BE MARKED OR DISPLAYED ON THE SALE OF
UNPACKETED SEED

Particulars to be marked or displayed on the sale of unpacketed seed

9. The following particulars shall be marked on, or displayed near, the container referred to in regulation 18:—

- (a) the words “complies with legal standards”;
- (b) species; and
- (c) except in the case of Commercial Seed, variety.

PART V
INFORMATION IN RESPECT OF SEED IMPORTED FROM COUNTRIES
WHICH ARE NOT EEA STATES IN PACKAGES EXCEEDING 2 KILOGRAMS
NET WEIGHT

Information to be supplied in respect of seed imported from a country which is not an EEA State in a package exceeding 2 kilograms net weight

10. The information to be supplied to the Scottish Ministers in accordance with regulation 6(5) in respect of seed imported from a country which is not an EEA State in a package exceeding 2 kilograms of seed is as follows:—

- (a) species;
- (b) variety;
- (c) category;
- (d) country of production and official inspection authority;
- (e) country of despatch;
- (f) importer; and
- (g) quantity of seed.

PART VI
PRINTING OF SPECIFIED MATTERS ON PACKAGES
(WHOLE BAG LABELLING)

Packages sealed in Scotland - printers’ returns

11. Arrangements shall be made with the printers for returns to be made to the Scottish Ministers of the number of packages printed or stamped pursuant to regulations 17(10) and 21(5) and of the individual serial numbers of such packages.

Packages sealed in Scotland - individual serial numbers

12. Each package shall have printed or stamped on it, or be perforated with, an individual serial number allocated by the Scottish Ministers, which shall appear in the same panel as the particulars of the matters specified in Part II of this Schedule.

Packages sealed in Scotland - printing or stamping

13. The printing or stamping of the packages shall be by, and in accordance with the instructions, of the Scottish Ministers or by a licensed seed sampler.

Packages sealed in Scotland - particulars to be included in the printing or stamp

14. The reference number of the seed lot and the month and year in which the package was officially sealed shall be printed or stamped by the Scottish Ministers or a licensed seed sampler at the time of sampling for official examination.

Packages sealed in Scotland - lower germination seed

15. Each package of seed marketed in accordance with regulation 17(10) shall be capable of having affixed to it, in a manner approved by the Scottish Ministers, a label containing a statement pursuant to regulation 17(6).

Packages sealed in Scotland - record keeping for lower germination seed

16. There shall be kept such records of seed packaged and marketed pursuant to regulation 17(10) as may be required by the Scottish Ministers.

Seed packages sealed in the United Kingdom but not in Scotland, or in an EEA State other than the United Kingdom

17. (a) Such requirements of the EEA State (if the seed was sealed in that EEA State) or the Department of Agriculture and Rural Development (if the seed was sealed in Northern Ireland), the National Assembly for Wales (if the seed was sealed in Wales) or the Secretary of State (if the seed was sealed in England) as correspond to the requirements specified in paragraphs 11 to 16 of this Part of this Schedule for seed which has been sealed in Scotland shall be satisfied; and
- (b) the Scottish Ministers shall be satisfied that the requirements specified in sub-paragraph (a) have been met.

SCHEDULE 7

Regulation 23(2)

LIMITS OF VARIATION

GERMINATION

Minimum percentage of germination (expressed as an integer)	Limit of variation per cent
99-100	2
97-98	3
94-96	4
91-93	5
87-90	6
82-86	7
76-81	8
70-75	9

ANALYTICAL PURITY

Minimum percentage of analytical purity (expressed to one decimal point)	Limit of variation per cent
99.9-100	0.2
99.8	0.3
99.6-99.7	0.4
99.3-99.5	0.5
99.0-99.2	0.6
98.5-98.9	0.7
98.3-98.4	0.8
97.5-98.2	0.9
97.0-97.4	1.0
96.5-96.9	1.1
95.5-96.4	1.2
95.0-95.4	1.3

CONTENT OF SEEDS OF OTHER SPECIES

Maximum percentage (by weight) of number of seeds of other species (expressed to one decimal point)	Limit of variation per cent
0.0	0.1
0.1-0.2	0.3
0.3-0.4	0.4
0.5	0.5

NUMBER OF SEEDS OF OTHER SPECIES

Maximum number of seeds of other species	Limit of variation number
0	1
1	3
2	4
3 and 4	5
5 and 6	6
7 and 8	7
9 to 11	8
12 to 14	9
15 to 17	10
18 to 21	11
22 to 25	12
26 to 29	13
30 to 34	14
35 to 40	15
41 to 45	16
46 to 50	17

SCHEDULE 8

Regulation 27(1)

REVOCATIONS

Regulations revoked	References	Extent
The Oil and Fibre Plant Seeds Regulations 1993	S.I. 1993/2007	The whole Regulations insofar as they apply to Scotland
The Oil and Fibre Plant Seeds (Amendment) Regulations 1994	S.I. 1994/1423	The whole Regulations insofar as they apply to Scotland
The Oil and Fibre Plant Seeds (Amendment) Regulations 1996	S.I. 1996/1451	The whole Regulations insofar as they apply to Scotland
The Seeds (Miscellaneous Amendments) Regulations 1997	S.I. 1997/616	Regulation 2, and insofar as it applies to the Oil and Fibre Plant Seeds Regulations 1993, regulation 4(2), all insofar as the Regulations apply to Scotland
The Oil and Fibre Plant Seeds (Amendment) Regulations 1999	S.I. 1999/1862	The whole Regulations insofar as they apply to Scotland
The Oil and Fibre Plant Seeds (Amendment) (Scotland) Regulations 2000	S.S.I. 2000/249	The whole Regulations
The Seeds (National Lists of Varieties) Regulations 2001	S.I. 2001/3510	Regulation 25(5)(a) insofar as it applies to Scotland
The Oil and Fibre Plant Seeds (Amendment) (Scotland) Regulations 2003	S.S.I. 2003/304	The whole Regulations

EXPLANATORY NOTE

(This note is not part of the Regulations)

These Regulations, which extend to Scotland only, consolidate, with amendments, the provisions of the Oil and Fibre Plant Seeds Regulations 1993 (S.I. 1993/2007) as relevantly amended by the Oil and Fibre Plant Seeds (Amendment) Regulations 1994 (S.I. 1994/1423), the Oil and Fibre Plant Seeds (Amendment) Regulations 1996 (S.I. 1996/1451), the Seeds (Miscellaneous Amendments) Regulations 1997 (S.I. 1997/616), the Oil and Fibre Plant Seeds (Amendment) Regulations 1999 (S.I. 1999/1862), the Oil and Fibre Plant Seeds (Amendment) (Scotland) Regulations 2000 (S.S.I. 2000/249), the Seeds (National Lists of Varieties) Regulations 2001 (S.I. 2001/3510) and the Oil and Fibre Plant Seeds (Amendment) (Scotland) Regulations 2003 (S.S.I. 2003/304), (“the 1993 Regulations”).

The 1993 Regulations implemented the provisions of Council Directive 69/208/EEC on the marketing of seed of oil and fibre plants (O.J. No. L 169, 10.7.69, p.3, OJ/SE 1969 (11), p.315). That Directive, as amended, was replaced by Council Directive 2002/57/EC on the marketing of seed of oil and fibre plants (O.J. No. L 193, 20.7.02, p.74) as amended by Council Directive 2002/68/EC (O.J. No. L 195, 24.7.02, p.32), Commission Directive 2003/45/EC (O.J. No. L 138, 5.6.03, p.40) and Council Directive 2003/61/EC (O.J. No. L 165, 3.7.03, p.23). These Regulations implement the provisions of that Directive, subject to exemptions for caraway, cotton, hemp and opium poppy contained in Commission Decision 74/360/EEC (O.J. No. L 196, 19.7.74, p.18) and the exemption for safflower contained in Commission Decision 89/101/EEC (O.J. No. L 38, 10.2.89, p.37) and the withdrawal of the exemption for hemp contained in Commission Decision 2003/234/EC (O.J. No. L 86, 3.4.03, p.48).

The Regulations apply to the certification and marketing of seed of oil and fibre plants of the species specified in Schedule 1 to these Regulations (regulation 4 and Schedule 1). The Regulations introduce the power to require an additional sample of seed for the purposes of European tests and trials (regulation 22 and regulation 27(3)) from 26th September 2004. The rest of the Regulations apply to all hemp seed, varietal associations of seed and seed of hybrid varieties from 26th September 2004. The Regulations (other than regulation 22) also apply to all other oil and fibre seed from 26th September 2004 except seed harvested on or before that date, to which the Regulations will not apply until 1st July 2005 (regulation 27).

The Regulations include provisions which prohibit the marketing of seed of oil and fibre plants in Scotland unless it is Commercial Seed, seed of a listed variety which has been officially certified or Breeder’s Seed (regulation 6(1)). The prohibition does not apply in the case of seed:

- (a) which has not yet been fully certified if it is marketed for processing (regulation 6(2));
- (b) which forms part of a mixture permitted by the Fodder Plant Seeds Regulations 1993 (S.I. 1993/2009, as amended by S.I. 1993/2529, 1996/1453, 1997/616, 1999/1864 and S.I. 2000/247) (regulation 7);
- (c) where authorisation has been granted for scientific purposes or selection work or for the purpose of tests and trials (regulation 8);
- (d) of certain varietal associations of seed (regulation 9); or
- (e) the marketing of which is authorised by general licence made under regulation 10.

The Regulations include provisions about the standards to be met by oil and fibre plant seed before it will be officially certified by the Scottish Ministers (regulations 3 and 14 and Schedules 2 and 4). There are provisions allowing marketing of seed which does not attain the relevant germination standards (regulation 11) and for marketing of seed before it is shown to meet the relevant germination standards (regulation 12).

The Regulations make provisions for breeder’s confirmations for seed which is not yet accepted on to a UK National List or the Common Catalogue but which otherwise meets the requirements for Pre-basic Seed or Basic Seed (regulations 3 and 19, and Schedules 2 and 4) and for upgrading a breeder’s confirmation to an official certificate (regulation 14(3)).

The Regulations lay down requirements relating to seed sampling (regulation 15 and Schedule 5) and the packaging and sealing of packages of seed (regulations 16, 18 and 20) and the labelling of packages of such seed (regulations 17, 18 and 21 and Schedule 6).

The Regulations provide that particulars given to a purchaser by a seller of seed to which the Regulations apply will constitute a statutory warranty so far as they relate to certain information about the seed being sold (regulation 23).

The Regulations introduce provisions about service of notices (regulation 24) and permit electronic communications to be used in certain circumstances (regulation 25).

The Regulations amend the Seeds (Fees) (Scotland) Regulations 2002 (S.S.I. 2002/526) to allow fees to be charged for procedures carried out in relation to the Regulations (regulation 26).

General licences made under the 1993 Regulations will be replaced by general licences made under these Regulations (regulation 27).

The Regulations introduce the power to require an additional sample of seed for the purposes of European tests and trials (regulation 22).

Contravention of these Regulations is a criminal offence (section 16(7) of the Plant Varieties and Seeds Act 1964).

A copy of the Scottish Ministers' requirements in respect of previous cropping can be obtained from SEERAD, Pentland House, 47 Robb's Loan, Edinburgh EH14 1TY.

No regulatory impact assessment has been prepared for these Regulations.