

SCHEDULE 15

(see regulation 94(1), (4), (6) and (9) to (12))

Conditions to be complied with in relation to the use of vehicles carrying wide or long loads or vehicles carrying loads or having fixed appliances or apparatus which project

Part I

Advance notice to Police

1. The conditions referred to in regulation 94(4)(ii)(A), (6), (9) and (11)(b)(ii) are—
 - (a) before using on a road a vehicle to which this Schedule applies, the owner shall give at least two clear working days notice in writing of the intended use to the Chief Constable of the Royal Ulster Constabulary, and the notice shall include the following details—
 - (i) time, date and route of the proposed journey, and
 - (ii) in a case to which regulation 6(15) applies, the overall length of the trailer,
 - (iii) in a case to which regulation 94(3) applies, the overall length and width of the vehicle by which the load is carried and the width of the lateral projection of its load,
 - (iv) in a case to which regulation 94(6)(a) applies, the overall length and width of each vehicle by which the load is carried, the length of any forward or rearward projection and, where the load rests on more than one vehicle, the distance between the vehicles,
 - (v) in a case to which regulation 94(6)(b) applies, the overall length of the combination of vehicles and the length of any forward or rearward projection of the load, and
 - (vi) in a case to which regulation 94(9) and (10) applies, the overall length of the vehicle and the length of any forward or rearward projection of the load or special appliance or apparatus.

The Chief Constable of the Royal Ulster Constabulary may, at his discretion, accept a shorter period of notice or fewer details.

- (b) The vehicle shall be used only in accordance with the details specified in sub-paragraph (a) subject to any variation in the time, date or route which may be directed by—
 - (i) the Chief Constable of the Royal Ulster Constabulary to the owner of the vehicle, or
 - (ii) a constable to the driver in the interests of road safety or in order to avoid undue traffic congestion by halting the vehicle in a place on or adjacent to the road on which the vehicle is travelling.

In this paragraph—

- (i) “working day” means a day which is not a Sunday, a bank holiday, Christmas Day or Good Friday, and
- (ii) “bank holiday” means a day which is a bank holiday under section 1 of the Banking and Financial Dealings Act 1971(1).

Attendants

2. The conditions referred to in regulation 94(4)(ii)(B), (6), (9) and (11)(b)(ii) are—

Status: This is the original version (as it was originally made). This item of legislation is currently only available in its original format.

- (1) Subject to sub-paragraph (2) at least one person in addition to the person employed in driving the vehicle shall be employed—
 - (a) in attending to that vehicle and its load and any other vehicle drawn by that vehicle and the load carried on the vehicle so drawn, and
 - (b) to give warning to the driver of the motor vehicle and to any person of any danger likely to be caused to him by reason of the presence of the said vehicle on the road.
- (2) Where three or more vehicles are travelling together in convoy, it shall be sufficient compliance with this paragraph if only the foremost and rearmost vehicles in the convoy are attended as prescribed in sub-paragraph (1).
- (3) When a motor vehicle is drawing a trailer—
 - (i) any person employed in pursuance of regulation 105 in attending that vehicle or trailer shall be treated as being an attendant required by this paragraph so long as he is also employed to discharge the duties mentioned in sub-paragraph (1); and
 - (ii) when another motor vehicle is used for the purpose of assisting in their propulsion on the road, the person employed in driving that other motor vehicle shall not be treated as a person employed in attending to the first-mentioned vehicle or any vehicle drawn by it.

Marking of longer projections

3. The conditions referred to in regulation 94(9) and (12) are—
 - (a) a forward and rearward projection shall be fitted with—
 - (i) an end marker, except in the case of a rearward projection which is fitted with a rear marking in accordance with the Lighting Regulations, and
 - (ii) where required by sub-paragraphs (c) and (d) two or more side markers which shall be of the size, shape and colour described in Part II;
 - (b) the end marker shall be so fitted that—
 - (i) it is as near to the projection as is practicable in a transverse plane,
 - (ii) it is not more than 0.5m from the extreme end of the projection,
 - (iii) the vertical distance between the lowest point of the marker and the road surface is not more than 2.5m,
 - (iv) it, and any means by which it is fitted to the projection impedes the view of the driver as little as possible, and
 - (v) it is clearly visible within a reasonable distance to a person using the road at the end of the vehicle from which the projection extends;
 - (c) where the forward projection exceeds 2m or the rearward projection exceeds 3m, one side marker shall be fitted on the right hand side and one on the left hand side of the projection so that—
 - (i) each marker is as near to the projection as is practicable in a longitudinal plane,
 - (ii) no part extends beyond the end of the projection,
 - (iii) the vertical distance between the lowest part of each marker and the surface of the road is not more than 2.5m,
 - (iv) the horizontal distance between each marker and the end marker or, as the case may be, the rear marking carried in accordance with the Lighting Regulations does not exceed 1m, and
 - (v) each marker is clearly visible within a reasonable distance to a person using the road on that side of the projection;

(d) where—

- (i) a forward projection exceeds 4.5m, or
- (ii) a rearward projection exceeds 5m

extra side markers shall be fitted on either side of the projection so that the horizontal distance between the extreme projecting point of the vehicle from which the projection extends and the nearest point on any side marker from that point, and between the nearest points of any adjacent side markers on the same side does not exceed—

2.5m in the case of a forward projection, or

3.5m in the case of a rearward projection.

For the purpose of this sub-paragraph the expression “the vehicle” shall not include any special appliance or apparatus or any part of them which is a forward projection or a rearward projection within the meaning given to those expressions in regulation 94;

- (e) the extra side markers required by this sub-paragraph shall also meet the requirements of (i), (iii) and (v) of sub-paragraph (c);
- (f) every marker fitted in accordance with this paragraph shall be kept clean and unobscured and between sunset and sunrise be illuminated by a lamp which renders it readily visible from a reasonable distance and which is so shielded that its light, except as reflected from the marker, is not visible to other persons using the road.

Marking of shorter projections

4. The conditions referred to in regulation 94(9), (10)(a) and (12) are that a projection shall be rendered clearly visible to other persons using the road within a reasonable distance, in the case of a forward projection, from the front thereof or, in the case of a rearward projection, from the rear thereof and, in either case, from either side thereof.

Marking of wide loads

- (a) (a) Subject to sub-paragraph (d), every load carried on a vehicle in circumstances where this paragraph applies shall be fitted on each side and in the prescribed manner, with—
 - (i) a prescribed marker in such a position that it is visible from the front of the vehicle, and
 - (ii) a prescribed marker in such a position that it is visible from the rear of the vehicle;
- (b) for the purposes of sub-paragraph (a)—
 - (i) a marker on a side of the load is fitted in the prescribed manner if at least part of it is within 50mm of a longitudinal plane passing through the point on that side of the load which is furthest from the axis of the vehicle; and
 - (ii) a prescribed marker is a marker of the size, shape and colour described in Part II;
- (c) every marker fitted pursuant to this paragraph shall be kept clean and between sunset and sunrise be illuminated by a lamp which renders it readily visible from a reasonable distance and which is so shielded that its light, except as reflected from the marker, is not visible to other persons using the road;
- (d) if the load does not extend beyond the longitudinal plane passing through the extreme projecting point on one side of the vehicle, it shall not be necessary for a marker to be fitted to the load on that side.

(see paragraph 3(a) and 5(b) of Part I)

Status: This is the original version (as it was originally made). This item of legislation is currently only available in its original format.

Part II

Projection Markers

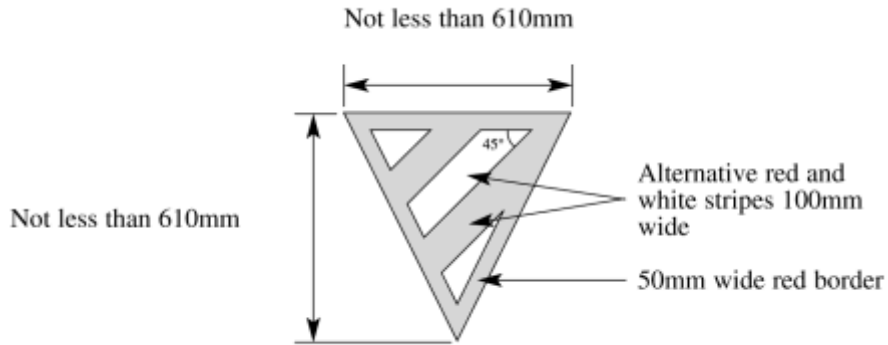

Diagram of side marker surface

