STATUTORY RULES OF NORTHERN IRELAND

1999 No. 121

ROAD TRAFFIC AND VEHICLES

**Traffic Signs (Temporary Obstructions)
Regulations (Northern Ireland) 1999**

Made - - - - *15th March 1999*

Coming into operation *26th April 1999*

The Department of the Environment, in exercise of the powers conferred on it by Article 30(1) of the Road Traffic Regulation (Northern Ireland) Order 1997(1) and of every other power enabling it in that behalf, hereby makes the following Regulations:

Part I

Preliminary

Citation and commencement

1. These Regulations may be cited as the Traffic Signs (Temporary Obstructions) Regulations (Northern Ireland) 1999 and shall come into operation on 26th April 1999.

Interpretation

2.—(1) In these Regulations—

“the 1997 Regulations” means the Traffic Signs Regulations (Northern Ireland) 1997(2);

“EEA State” means a State which is a contracting Party to the Agreement on the European Economic Area signed at Oporto on 2nd May 1992(3) as adjusted by the Protocol signed at Brussels on 17th March 1993(4);

“flat traffic delineator” means a traffic sign of the size, colour and type prescribed by regulation 8;

“keep right sign” means a traffic sign of the size, colour and type prescribed by regulation 7;

“reflectorised” means illuminated with retroreflecting material, that is to say material which reflects a ray of light back towards the source of that light;

(1) S.I.1997/276 (N.I. 2); see Article 2(2) for the definition of “the Department”

(2) S.R. 1997 No. 386

(3) Cmnd 2073

(4) Cmnd 2183

“road vehicle sign” means a traffic sign of the size, colour and type prescribed by regulation 9;
“traffic cone” means a traffic sign of the size, colour and type prescribed by regulation 10;
“traffic pyramid” means a traffic sign of the size, colour and type prescribed by regulation 11;
“traffic triangle” means a traffic sign of the size, colour and type prescribed by regulation 12;
and
“warning lamp” means a traffic sign of the type prescribed by regulation 13.

(2) The dimensions indicated in the diagrams in the Schedules are all expressed in millimetres.

Part II

Significance of Traffic Signs

Keep right sign

3. In addition to the requirement conveyed by the sign shown in diagram 610 in Schedule 2 to the 1997 Regulations in accordance with those Regulations, a keep right sign shall convey to vehicular traffic a warning of a temporary obstruction.

Flat traffic delineator and traffic cone

4. In addition to indicating the edge of a route for vehicular traffic through or past a temporary obstruction in accordance with the 1997 Regulations, a traffic cone and a flat traffic delineator shall each convey to such traffic on a road a warning of an obstruction in the road.

Road vehicle sign

5. A road vehicle sign shall convey to vehicular traffic using a road a warning of a temporary obstruction in the road caused by a stationary vehicle.

Traffic pyramid, traffic triangle and warning lamp

6. A traffic pyramid, a traffic triangle and a warning lamp shall each convey to vehicular traffic using a road a warning of a temporary obstruction in the road, other than an obstruction caused by the carrying out of works.

Part III

Size, Colour and Type of Traffic Signs

Keep right sign

7. A keep right sign shall consist of a device which is—
- of the colour and type of the traffic sign shown in diagram 610 in Schedule 2 to the 1997 Regulations varied so that the arrow points downwards to the right;
 - of the size shown in that diagram except that its minimum diameter shall be 900 millimetres instead of 270 millimetres; and
 - illuminated in accordance with the provisions in column (3) of item 1 of Schedule 17 to the 1997 Regulations.

Flat traffic delineator

8. A flat traffic delineator shall consist of a device which is of the type specified in, and complies with the provisions of, regulation 45(3) of the 1997 Regulations and is of the colour and type of the traffic sign shown in the two parts of diagram 7102 in Schedule 12 to those Regulations, except that—

- (a) its minimum height shall be 450 millimetres instead of 750 millimetres; and
- (b) it shall not have the optional white strip on its base referred to in regulation 45(3)(a) and shown in the second part of diagram 7102.

Road vehicle sign

9. A road vehicle sign shall consist of a device which is of the size, colour and type specified in the diagram in Schedule 1.

Traffic cone

10. A traffic cone shall consist of a device which—

- (a) complies with the requirements of regulation 45(1) of the 1997 Regulations; and
- (b) is of the size, colour and type of the traffic sign shown in diagram 7101 in Schedule 12 to the 1997 Regulations.

Traffic pyramid

11. A traffic pyramid shall consist of a device which is—

- (a) pyramidically shaped with at least three visible faces, each of which is of the size and colour specified in one of the diagrams in Schedule 2;
- (b) made of rubber or flexible plastic material; and
- (c) so constructed that it can stand upright firmly on the surface of a road.

Traffic triangle

12. A traffic triangle shall consist of a device which is—

- (a) of the size, colour and type specified in either of the diagrams in Schedule 3; and
- (b) legibly and permanently marked—
 - (i) in the case of a triangle of the size, colour and type specified in the first diagram in Schedule 3, with the specification number of the British Standard for an Advance Warning Triangle to indicate a temporary obstruction, namely BS: AU47: 1965 as amended by Amendment No. 1 of 6th May 1966, or the specification number of an equivalent standard which has been approved by a recognised standardising body in an EEA State; or
 - (ii) in the case of a triangle of the size, colour and type specified in the second diagram in Schedule 3, with the marking designated as an approval mark by regulation 4 of the Motor Vehicles (Designation of Approval Marks) Regulations 1979(5) and shown in item 27 of Schedule 2 to those Regulations.

Warning lamp

13. A warning lamp shall consist of a device which—

(5) S.I. 1979/1088 to which there are amendments not relevant to these Regulations

- (a) shows an intermittent amber light having a flashing rate of not less than 55 nor more than 150 flashes per minute; and
- (b) is illuminated by either—
 - (i) a single source of light; or
 - (ii) two or more sources of light mounted adjacent to each other and flashing in such a manner that all the sources of light are illuminated or extinguished simultaneously.

Part IV

Placing of Traffic Signs

Authorisation to place traffic signs

14.—(1) Subject to paragraph (4), a person who is in charge of or accompanies an emergency vehicle or a breakdown vehicle which is temporarily obstructing a road is hereby authorised to place a keep right sign for the purpose of warning vehicular traffic of the obstruction created by the vehicle and to indicate the way past the vehicle.

(2) Subject to paragraph (4), any person not otherwise authorised to do so is hereby authorised to place a road vehicle sign on a vehicle or a flat traffic delineator, traffic cone, traffic pyramid, traffic triangle or warning lamp on any road for the purpose of warning traffic of a temporary obstruction in the road, other than one caused by the carrying out of works.

(3) In paragraph (1), the expressions “emergency vehicle” and “breakdown vehicle” have the meanings assigned to them in regulation 3(1) of the Road Vehicles Lighting Regulations (Northern Ireland) 1995⁽⁶⁾.

(4) The authorisations given by paragraphs (1) and (2) are subject to the conditions prescribed by regulation 15.

Conditions of authorisation

15.—(1) In this regulation—

- (a) “placed” in relation to a traffic sign means placed in pursuance of an authorisation given by regulation 14;
- (b) references to “the obstruction” are to the temporary obstruction in relation to which a traffic sign is placed; and
- (c) references to “the road” are to the road on which the obstruction is situated.

(2) A traffic sign which has been placed shall be removed as soon as the obstruction has been removed.

(3) A flat traffic delineator, keep right sign, traffic cone, traffic pyramid or traffic triangle shall be placed in an upright position.

(4) A flat traffic delineator, keep right sign, traffic cone or traffic pyramid shall be placed so as to guide traffic past the obstruction.

(5) A traffic sign referred to in column (2) of an item in the Table may be placed only if the conditions specified in column (3) of the item are complied with.

(6) S.R. 1995 No. 449

Table

<i>Item</i> (1)	<i>Traffic sign</i> (2)	<i>Conditions</i> (3)
1.	Flat traffic delineator	<p>1. At least three other flat traffic delineators shall also be placed in relation to the obstruction.</p> <p>2. Each flat traffic delineator shall be so placed as to face traffic approaching the obstruction from the side of the obstruction on which it is placed.</p>
2.	Road vehicle sign	<p>1. It shall be placed to face traffic approaching the stationary vehicle from the front, rear or side of the vehicle on which it is placed.</p> <p>2. It shall be securely fixed to the stationary vehicle.</p> <p>3. It shall not obscure any registration plate or lamps or reflectors of the stationary vehicle.</p>
3.	Traffic cone	At least three other traffic cones shall also be placed in relation to the obstruction.
4.	Traffic pyramid	At least three other traffic pyramids shall also be placed in relation to the obstruction.
5.	Traffic triangle	<p>1. A traffic triangle shall be placed at least 45 metres away from the obstruction.</p> <p>2. A traffic triangle shall be so placed as to face traffic approaching the obstruction from the side of the obstruction on which it is placed.</p>
6.	Warning lamp	<p>1. A warning lamp may be used only in conjunction with another traffic sign lawfully placed in accordance with these Regulations being—</p> <p>(a) a flat traffic delineator;</p> <p>(b) a keep right sign;</p>

Status: This is the original version (as it was originally made). Northern Ireland Statutory Rules are not carried in their revised form on this site.

<i>Item</i>	<i>Traffic sign</i>	<i>Conditions</i>
(1)	(2)	(3)
		(c) a road vehicle sign; (d) a traffic cone; (e) a traffic pyramid; or (f) a traffic triangle, and shall be so placed as not to obscure that other traffic sign from the view of approaching traffic. 2. Not more than one warning lamp shall be placed in conjunction with each such other traffic sign.

Part V

Savings

Savings

16. Nothing in these Regulations shall affect regulation 42 (Certain temporary signs) of the 1997 Regulations.

17. Nothing in the Motorways Traffic Regulations (Northern Ireland) 1984(7) shall preclude any person, acting in accordance with an authorisation conferred by Part IV, from placing a flat traffic delineator, keep right sign, traffic cone, traffic pyramid, traffic triangle or warning lamp on, or having placed it there removing it from, a special road to which those Regulations apply.

Part VI

Miscellaneous

Revocation

18. The Traffic Signs (Temporary Obstructions) Regulations (Northern Ireland) 1975(8) are hereby revoked.

(7) S.R. 1984 No. 160 as amended by S.R. 1994 No. 190 and S.R. 1997 No. 468

(8) S.R. 1975 No. 315

Sealed with the Official Seal of the Department of the Environment on

15th March 1999.

J. Carlisle
Assistant Secretary

SCHEDULE 1

Regulation 9

The Road Vehicle Sign

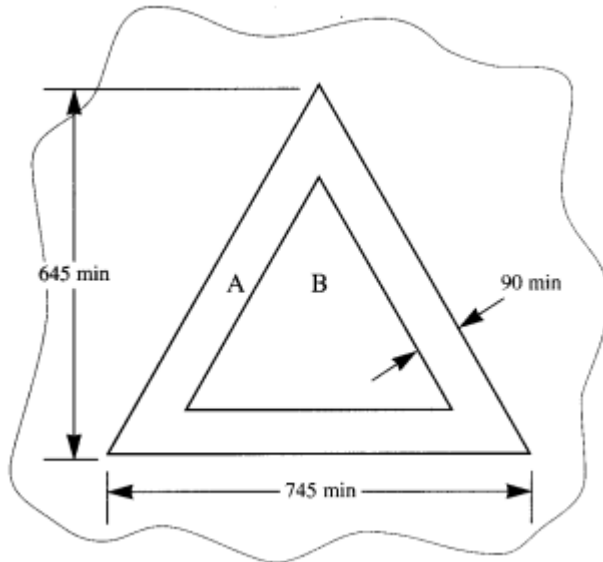

1. A road vehicle sign shall be a flexible sheet on which appears a triangle.
2. The triangle shall be equilateral. The area marked A in the diagram shall be coloured red, and shall be reflectorised to Class 1 of British Standard Specification BS 873: Part 6 or an equivalent standard which has been approved by a recognised standardising body in an EEA State.
3. The area marked B in the diagram may be coloured white, in which case it shall be reflectorised to Class 1 of British Standard Specification BS 873: Part 6 or an equivalent standard which has been approved by a recognised standardising body in an EEA State. If the area marked B is not coloured white it shall be of the same colour as the background specified in note 4.
4. The background shall be coloured yellow which shall be fluorescent and may also be reflectorised.
5. The total area of the sheet, including the red triangle, shall be not less than 0.8 square metres.

SCHEDULE 2

Regulation 11

The Traffic Pyramid — First Diagram

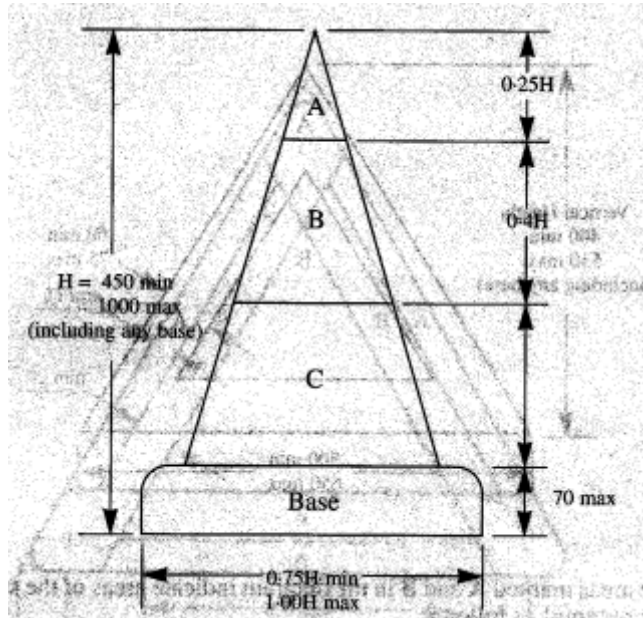

1. The areas marked A, B and C in the diagram indicate areas of the surface on each face of the pyramid as follows:

A — Surface coloured red which may be reflectorised.

B — Surface coloured white which shall be reflectorised.

C — Surface coloured red which may be reflectorised. Up to 50% of this surface may be obscured by constructional components.

2. The pyramid shall not be directly illuminated either internally or externally.

3. The base may be of any colour or it may be omitted.

The Traffic Pyramid — Second Diagram

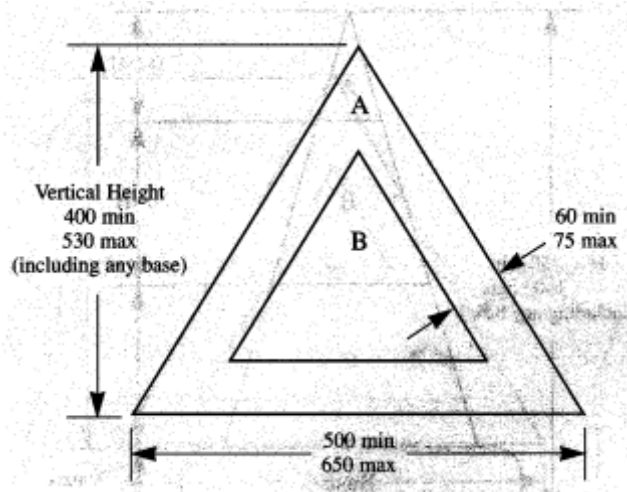

1. The areas marked A and B in the diagram indicate areas of the surface on each face of the pyramid as follows:

- A — Surface coloured red which may be reflectorised.
- B — Surface coloured white which shall be reflectorised.

2. Each outer edge of the triangular face shall be the same length.

3. The pyramid shall not be directly illuminated either internally or externally.

SCHEDULE 3

Regulation 12

The Traffic Triangle — First Diagram

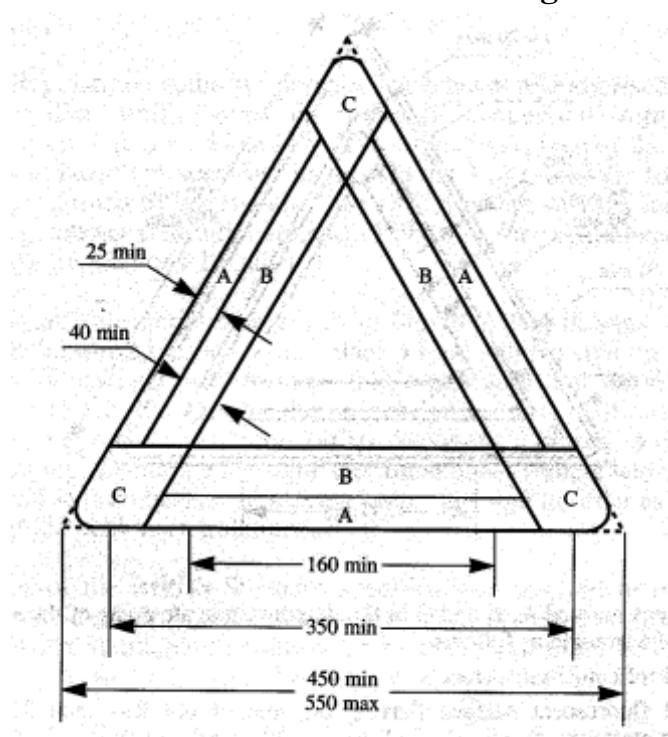

1. The areas marked A, B and C in the diagram indicate areas of the surface on the face of the triangle as follows:

A — Red reflectorised surface. Not more than a total of 15 square centimetres may be obscured by constructional components.

B — Red fluorescent surface.

C — May have either red reflectorised surface or a combination of both red reflectorised and red fluorescent surface. Not more than 10 square centimetres in each corner may be obscured by constructional components.

2. The corners shall be radiused.

3. All sides shall be the same length.

4. The reflectorised areas of the surface may be internally illuminated provided that such illumination is steady, presents a uniform appearance throughout that area and does not impair the retroreflecting properties of that area of the surface. The triangle shall not be directly illuminated externally.

The Traffic Triangle — Second Diagram

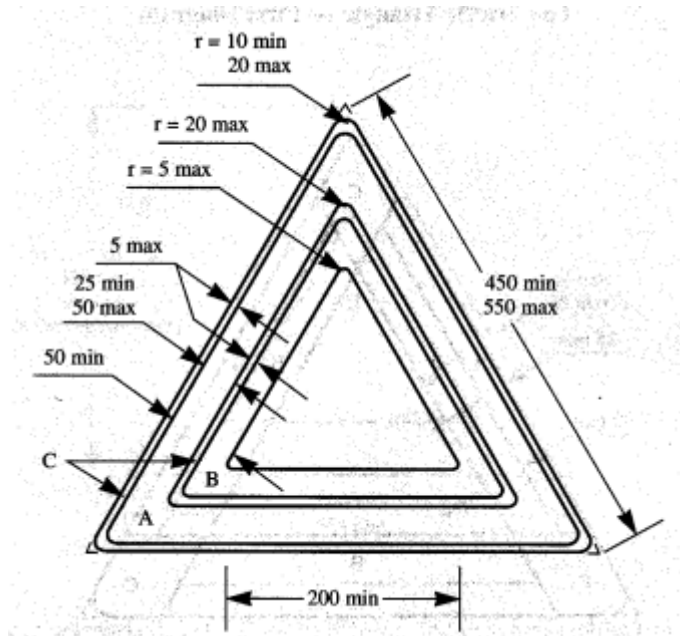

1. The areas marked A, B and C in the diagram indicate areas of the surface on each face of the triangle as follows:

A — Red reflectorised surface.

B — Red fluorescent surface (having an area of not less than 315 square centimetres).

C — Red edging which may be omitted.

2. The corners shall be radiused.

3. All sides shall be the same length.

4. The reflectorised areas of the surface may be internally illuminated provided that such illumination is steady, presents a uniform appearance throughout that area and does not impair the retroreflecting properties of that area of the surface. The triangle shall not be directly illuminated externally.

EXPLANATORY NOTE

(This note is not part of the Regulations.)

These Regulations revoke and re-enact with amendments the Traffic Signs (Temporary Obstructions) Regulations (Northern Ireland) 1975 (“the 1975 Regulations”).

The Regulations authorise persons not otherwise authorised to do so to place specified traffic signs on roads in connection with temporary obstructions (regulations 14 and 15). The indications given by the signs which may be so placed are specified in regulations 3 to 6 and the form of those signs

is prescribed by regulations 7 to 13. There are savings for the Traffic Signs Regulations (Northern Ireland) 1997 and for regulations relating to motorways (regulations 16 and 17).

There are substantial changes from the 1975 Regulations. Persons not otherwise authorised to do so may place a road vehicle sign on a vehicle or flat traffic delineators, traffic cones, traffic pyramids and warning lamps in addition to traffic triangles for the purpose of warning traffic of temporary obstructions in roads (regulation 14(2)). Secondly, a person in charge of, or accompanying, an emergency vehicle or breakdown vehicle which is causing an obstruction is authorised to place a keep right sign in order to indicate the route past the vehicle (regulation 14(1)).

Copies of the British Standard specifications referred to in regulation 12(b)(i) and Schedule 1 can be obtained from any of the sales outlets operated by the British Standards Institution, or by post from that Institution at 389 Chiswick High Road, London, W4 4AL (telephone number 0181 996 7000).

These Regulations have been notified to the European Commission pursuant to Directive [98/34/EC](#) of 22nd June 1998 laying down a procedure for the provision of information in the field of technical standards and regulations and of rules on Information Society services (O.J. No. L204, 21.07.98, p. 37-48) as amended by Directive [98/48/EC](#) of 20th July 1998 (O.J. No. L217, 05.08.98, p. 18-26). Copies of the Directives can be obtained from the Stationery Office Bookshop, 16 Arthur Street, Belfast, BT1 4GD.