

SCHEDULE 13

Regulations 9(3) and 34

Information to be Displayed During Carriage

Part I

Packages and Overpacks

1. Paragraphs 2 to 11 shall apply to packages, other than excepted packages, and overpacks.

Common provisions

2.—(1) Each package and overpack shall display danger signs conforming to figure 2, 3 or 4 in Part III, according to the appropriate category.

(2) The danger signs referred to in sub-paragraph (1) shall be affixed to two opposite sides of the package or overpack.

3.—(1) Subject to sub-paragraph (5), the following information shall be legibly and durably marked on each danger sign displayed in accordance with paragraph 2—

- (a) in the upper half of each sign, the trefoil, conforming to the model depicted in figure 1 in Part III; and
- (b) in the lower half of each sign—
 - (i) the word “RADIOACTIVE” followed by a single, double or triple vertical bar to indicate the category,
 - (ii) the CONTENTS in accordance with sub-paragraphs (2) to (4),
 - (iii) the maximum ACTIVITY of the radioactive contents during carriage expressed in Bq with the appropriate SI prefix, except where the contents are fissile material where the total mass expressed in units of grammes (g) or multiples thereof may be displayed instead of activity,
 - (iv) for category II-YELLOW and category III-YELLOW, the Transport Index, and
 - (v) the figure “7” measuring not less than 25mm in height.

(2) Except for LSA-I, the CONTENTS shall comprise—

- (a) subject to sub-paragraph (3)—
 - (i) the symbol of the radionuclide, specified in Table I of paragraph 19 of the Approved Document, and
 - (ii) the element and atomic number (hereinafter referred to in this Schedule as the “name”) of that radionuclide, where one is specified in that Table; and
- (b) the group of LSA material or SCO (LSA-II, LSA-III, SCO-I or SCO-II, as appropriate), following the name of the radionuclide.

(3) For mixtures of radionuclides, the most restrictive nuclides shall be listed to the extent that the space on the line permits.

(4) For LSA-I, the CONTENTS shall comprise the term “LSA-I” only.

(5) The CONTENTS and ACTIVITY entries on each overpack shall reflect the entire contents of the overpack, except where the overpack concerned contains mixed loads of packages with different radionuclides, when those entries may be replaced by the words “see Carriage Information”.

4. Where the package or overpack contains any radioactive material listed in paragraph 20 of the Approved Document in respect of which a subsidiary hazard is specified in that paragraph, the

Status: This is the original version (as it was originally made). This item of legislation is currently only available in its original format.

appropriate subsidiary hazard sign, determined in accordance with regulation 5 of the CDGCPL Regulations and conforming to the specification in Schedule 2 to those Regulations shall—

- (a) be affixed to the package or overpack concerned, adjacent to each danger sign; and
- (b) have sides which measure not less than 100 mm.

5. Each package shall be legibly and durably marked with the UN number for the radioactive material shown in the Carriage Information.

Special provisions

6. Each package with a gross mass exceeding 50 kg shall be legibly and durably marked on the outside with its permissible gross mass.

7. Each TYPE A PACKAGE containing radioactive material other than fissile material shall be legibly and durably marked on the outside with the words “Type A”.

8. Each TYPE B(U) PACKAGE and each TYPE B(M) PACKAGE containing radioactive material other than fissile material shall be legibly and durably marked on the outside with—

- (a) the competent authority identification mark;
- (b) the serial number to identify uniquely the packaging which conforms to the design for that package;
- (c) the words “Type B(U)” or “Type B(M)”, as appropriate; and
- (d) the trefoil symbol depicted in figure 1 in Part III, embossed or stamped on the outermost fire and water resistant receptacle.

9. Each package and overpack containing fissile material shall be legibly and durably marked on the outside with—

- (a) the competent authority identification mark; and
- (b) the words “Type A”, “Type B(U)”, or “Type B(M)”, as appropriate.

10. Where an excepted package contains radioactive material of limited activity, the packaging shall be legibly and durably marked with the word “RADIOACTIVE” on an internal surface.

11. Where an excepted package contains any instrument or article (other than radio-luminescent time-pieces or devices) that instrument or article, as the case may be, shall be legibly and durably marked on the outside with the word “RADIOACTIVE”.

Part II

Freight Containers, Tank Containers, Tank Wagons and Wagons

Interpretation

12. For the purposes of paragraphs 13 to 20, any reference to the carriage of any radioactive material in a wagon shall include the carriage of radioactive material in a road vehicle on a wagon (“piggyback transport”).

Common provisions

13.—(1) Danger signs conforming to figure 2, 3 or 4 in Part III according to the appropriate category, shall be displayed on each freight container, tank container, tank wagon and wagon which is being used for the carriage of radioactive material, other than in the form of excepted packages.

Status: This is the original version (as it was originally made). This item of legislation is currently only available in its original format.

- (2) The danger signs referred to in sub-paragraph (1) shall—
- (a) be affixed to all four sides of the freight container, tank container, tank wagon or wagon;
 - (b) be affixed in a vertical plane, perpendicular to the longitudinal axis of the freight container, tank container, tank wagon or wagon; and
 - (c) be clearly visible.

14.—(1) Subject to sub-paragraph (5), the following information shall be legibly and durably marked on each of the danger signs displayed in accordance with paragraph 13—

- (a) in the upper half of each sign, the trefoil, conforming to figure 1 in Part III; and
- (b) in the lower half of each sign—
 - (i) the word “RADIOACTIVE” followed by a single, double or triple vertical bar to indicate the category,
 - (ii) the CONTENTS in accordance with sub-paragraphs (2) to (4),
 - (iii) the maximum ACTIVITY of the radioactive contents during carriage expressed in Bq with the appropriate SI prefix, except where the contents are fissile material where the total mass expressed in units of grammes (g) or multiples thereof may be displayed instead of the maximum activity,
 - (iv) for category II-YELLOW, and category III-YELLOW the TRANSPORT INDEX, and
 - (v) the figure “7”, measuring not less than 25mm in height.

(2) Except for LSA-I, the CONTENTS shall comprise—

- (a) subject to sub-paragraph (3), the symbol of the radionuclide, as specified in Table I of paragraph 19 of the Approved Document, and the name of that radionuclide, where one is specified in that Table; and
- (b) the group of LSA material or SCO (LSA-II, LSA-III, SCO-I or SCO-II, as appropriate), following the name of the radionuclide.

(3) For mixtures of radionuclides, the most restrictive nuclides shall be listed to the extent that the space on the line permits.

(4) For LSA-I, the CONTENTS shall comprise “LSA-I” only.

(5) The CONTENTS and ACTIVITY entries shall reflect the entire contents of the freight container, tank container, tank wagon or wagon, except where the freight container, tank container, tank wagon or wagon concerned contains mixed loads of packages with different radionuclides, when those entries may be replaced by the words “see Carriage Information”.

15.—(1) Subject to paragraph 17, danger signs conforming to figure 5 in Part III shall be displayed on each freight container, tank container, tank wagon or wagon which is being used for the carriage of radioactive material, other than in the form of excepted packages.

- (2) The danger signs referred to in sub-paragraph (1) shall—
- (a) be affixed to all four sides of the freight container, tank container, tank wagon or wagon;
 - (b) be affixed in a vertical plane, perpendicular to the longitudinal axis of the freight container, tank container, tank wagon or wagon; and
 - (c) be clearly visible.

16. The following information shall be legibly and durably marked on the danger signs displayed in accordance with paragraph 15—

- (a) in the upper half of each sign, the trefoil conforming to figure 1 in Part III; and

Status: This is the original version (as it was originally made). This item of legislation is currently only available in its original format.

- (b) in the lower half of each sign—
 - (i) the word “RADIOACTIVE”, and
 - (ii) the figure “7”, measuring not less than 25 mm in height.

17. The danger signs referred to in paragraph 15 need not be affixed to any freight container, tank container, tank wagon or wagon which is being used for the carriage of radioactive material, provided the sides of the danger signs displayed in accordance with paragraph 13 are enlarged to measure not less than 250 mm.

Special provisions

18. Where the consignment is unpackaged LSA-I or SCO-I for carriage in a freight container, tank container, tank wagon or wagon or the consignment is packaged radioactive material having a single UN number for carriage under exclusive use, the appropriate UN number for the consignment shall be displayed in black digits not less than 65 mm high either—

- (a) in the lower half of the danger signs displayed in accordance with paragraph 15; or
- (b) on orange-coloured panels conforming to figure 6 in Part III, which shall—
 - (i) be affixed immediately adjacent to the danger signs displayed in accordance with paragraph 13,
 - (ii) be affixed in a vertical plane and perpendicular to the longitudinal axis of the freight container, tank container, tank wagon or wagon, and
 - (iii) be clearly visible.

19. Where the freight container, tank container, tank wagon or wagon is being used for the carriage of any radioactive material listed in paragraph 20 of the Approved Document in respect of which a subsidiary hazard is specified in that paragraph, the appropriate subsidiary hazard sign, determined in accordance with regulation 5 of the CDGCPL Regulations and conforming to the specification in Schedule 2 to those Regulations shall—

- (a) be affixed to the freight container, tank container, tank wagon or wagon concerned adjacent to each danger sign; and
- (b) have sides which measure not less than 250 mm.

Part III

Symbols, Signs and Panels

Fig. 1. Trefoil Symbol

Fig. 1. Trefoil Symbol

Status: This is the original version (as it was originally made). This item of legislation is currently only available in its original format.

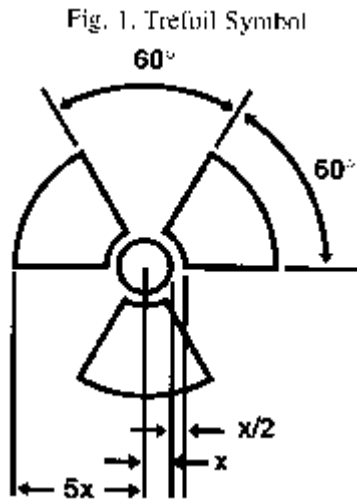

Fig. 2. Category I-WHITE LabelThe background colour of the label shall be white, the colour of the trefoil and the printing shall be in black, and the colour of the category bar shall be red.
Fig. 2. Category I-WHITE LabelThe background colour of the label shall be white, the colour of the trefoil and the printing shall be in black, and the colour of the category bar shall be red.

Fig. 2. Category I-WHITE Label



The background colour of the label shall be white, the colour of the trefoil and the printing shall be in black, and the colour of the category bar shall be red.

Fig. 3. Category II-YELLOW LabelThe background colour of the upper half of the label shall be yellow and the lower half white, the colour of the trefoil and the printing shall be in black, and the colour of the category bars shall be red.
Fig. 3. Category II-YELLOW LabelThe background colour of the upper half of the label shall be yellow and the lower half white, the colour of the trefoil and the printing shall be in black, and the colour of the category bars shall be red.

Status: This is the original version (as it was originally made). This item of legislation is currently only available in its original format.

Fig. 3. Category II-YELLOW Label



The background colour of the upper half of the label shall be yellow and the lower half white, the colour of the trefoil and the printing shall be in black, and the colour of the category bars shall be red.

Fig. 4. Category III-YELLOW LabelThe background colour of the upper half of the label shall be yellow and the lower half white, the colour of the trefoil and the printing shall be in black, and the colour of the category bars shall be red.

Fig. 4. Category III-YELLOW LabelThe background colour of the upper half of the label shall be yellow and the lower half white, the colour of the trefoil and the printing shall be in black, and the colour of the category bars shall be red.

Fig. 4. Category III-YELLOW Label



The background colour of the upper half of the label shall be yellow and the lower half white, the colour of the trefoil and the printing shall be in black, and the colour of the category bars shall be red.

Status: This is the original version (as it was originally made). This item of legislation is currently only available in its original format.

Fig. 5. Placard Minimum dimensions are given: when larger dimensions are used the relative proportions must be maintained. The figure “7” shall not be less than 25mm high. The background colour of the upper half of the placard shall be yellow and the lower half white, the colour of the trefoil and the printing shall be black. The use of the word “RADIOACTIVE” in the bottom half is optional to allow the alternative use of this placard to display the appropriate United Nations number for the consignments.

Fig. 5. Placard Minimum dimensions are given: when larger dimensions are used the relative proportions must be maintained. The figure “7” shall not be less than 25mm high. The background colour of the upper half of the placard shall be yellow and the lower half white, the colour of the trefoil and the printing shall be black. The use of the word “RADIOACTIVE” in the bottom half is optional to allow the alternative use of this placard to display the appropriate United Nations number for the consignments.

Fig. 5. Placard



Minimum dimensions are given: when larger dimensions are used the relative proportions must be maintained. The figure “7” shall not be less than 25mm high. The background colour of the upper half of the placard shall be yellow and the lower half white, the colour of the trefoil and the printing shall be black. The use of the word “RADIOACTIVE” in the bottom half is optional to allow the alternative use of this placard to display the appropriate United Nations number for the consignments.

Fig. 6. Placard for separate display of the United Nations number The background colour of the placard shall be orange and the border and United Nations number shall be black. The symbol “****” denotes the space in which the appropriate United Nations number for radioactive material, as specified in paragraph 20 of the Approved Document shall be displayed.

Fig. 6. Placard for separate display of the United Nations number The background colour of the placard shall be orange and the border and United Nations number shall be black. The symbol “****” denotes the space in which the appropriate United Nations number for radioactive material, as specified in paragraph 20 of the Approved Document shall be displayed.

Status: This is the original version (as it was originally made). This item of legislation is currently only available in its original format.

Fig. 6. Placard for separate display of the United Nations number

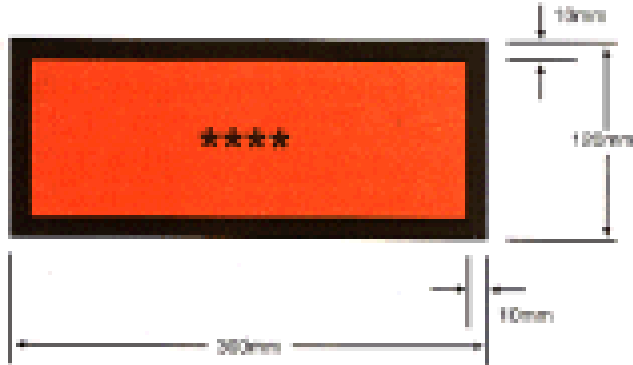

The background colour of the placard shall be orange and the border and United Nations number shall be black. The symbol "****" denotes the space in which the appropriate United Nations number for radioactive material, as specified in paragraph 20 of the Approved Document shall be displayed.