

1982 No. 338

AGRICULTURE

The Feeding Stuffs (Sampling and Analysis) Regulations
(Northern Ireland) 1982*Made* 19th October 1982*Coming into operation* 25th February 1983

ARRANGEMENT OF REGULATIONS

Regulation

1. Title, commencement and interpretation.
2. Prescribed amount for the purposes of the definition of sampled portion.
3. Manner of taking, dividing, marking, sealing and fastening of samples.
4. Methods of sending part of a sample.
5. Application of the methods of analysis.
6. Form of certificate of analysis.
7. Period within which analysis of the oil content of a feeding stuff must be carried out.
8. Modification of the Act as respects metrication.

SCHEDULES

- Schedule 1. Manner of taking, dividing, marking, sealing and fastening of samples.
- Part I Definitions.
 - Part II General instructions for the taking of samples.
 - Part III Quantitative requirements.
 - Part IV Taking and preparation of samples.
 - Part V Marking, sealing and fastening of the final sample.
 - Part VI Sampling tables.
- Schedule 2. Methods of analysis.
- Schedule 3. Form of certificate of analysis.

The Department(a) of Agriculture, in exercise of the powers conferred on it by Sections 66(1), 74A(b), 75(1), 76(1), 77(4), 78(6), 79(1), (2) and (9), 84 and 86(2), (5), (6), (7) and (9) of the Agriculture Act 1970(c) and of all other powers enabling it in that behalf, after consultation with such persons or organisations as appear to it to represent the interests concerned hereby makes the following regulations:

Title, commencement and interpretation

1.—(1) These regulations may be cited as the Feeding Stuffs (Sampling and Analysis) Regulations (Northern Ireland) 1982, and shall come into operation on 25th February 1983.

(2) In these regulations, unless the context otherwise requires, “the Act” means the Agriculture Act 1970.

(3) The Interpretation Act (Northern Ireland) 1954(d) shall apply to these regulations as it applies to a Measure of the Northern Ireland Assembly.

(a) Formerly Ministry: see 1973 c.36 s.40 Sch.5 para. 8(1)

(b) Inserted by 1972 c. 68 s. 4(1) and Sch. 4 para. 6

(c) 1970 c. 40

(d) 1954 c. 33 (N.I.)

Prescribed amount for the purposes of the definition of sampled portion

2.—(1) The prescribed amount of material for the purposes of the definition of sampled portion in section 66(1) of the Act shall be determined in accordance with the provisions of this regulation.

(2) In relation to solid feeding stuff in packages the prescribed amount shall be the quantity of material present or 5 tonnes, whichever is the less.

(3) In relation to solid feeding stuff in bulk containers, the prescribed amount shall be:—

- (a) the contents of the lowest number of containers which together hold not less than 5 tonnes; or
- (b) if all the containers together hold less than 5 tonnes or if all the feeding stuff is in one container, the quantity of material present; or
- (c) if any such bulk containers hold not less than 5 tonnes, the content of any such bulk container.

(4) In relation to solid feeding stuff which is loose in heaps or bays, the prescribed amount shall be:—

- (a) the contents of the lowest number of heaps or bays which together contain not less than 5 tonnes; or
- (b) if all the heaps or bays together contain less than 5 tonnes or if all the feeding stuff is in one heap or bay, the quantity of material present; or
- (c) if any such heaps or bays contain not less than 5 tonnes, the content of any such heap or bay.

(5) In relation to liquid or semi-liquid feeding stuff in containers, the prescribed amount shall be:—

- (a) the contents of the lowest number of containers which together hold not less than 5000 litres; or
- (b) if all the containers together hold less than 5000 litres or if all the feeding stuff is in one container, the quantity of material present; or
- (c) if any such containers hold not less than 5000 litres, the content of any such container.

Manner of taking, dividing, marking, sealing and fastening of samples

3. The manner in which samples are to be taken, divided, marked, sealed and fastened in cases where under Part IV of the Act they are taken in the prescribed manner shall be as set out in Schedule 1.

Methods of sending part of a sample

4. Any part of a sample required to be sent to any person in pursuance of subsection (1)(b) or (2) of section 77 of the Act shall be sent by registered post or by recorded delivery or may be delivered or given by hand.

Application of the methods of analysis

5.—(1) In respect of substances for which methods of analysis are specified in Schedule 2, the methods by which analyses of feeding stuffs shall be made for the purposes of the Act shall be those set out in the said Schedule.

(2) Method 10b in Schedule 2 shall not be used after 25th February 1984.

Form of certificate of analysis

6. The certificate of an agricultural analyst of the analysis shall be in the form set out in Schedule 3. The notes and the numbers referring to them in Part II of the said Schedule are for guidance only and do not form part of and need not appear on the certificate.

Period within which analysis of the oil content of a feeding stuff must be carried out

7. Where a sample of a feeding stuff has been taken by an inspector in the prescribed manner and sent to an agricultural analyst for analysis, any such analysis of the oil content of that feeding stuff shall be disregarded unless it is carried out before the end of 3 weeks commencing with the date of sampling.

Modification of the Act as respects metrication

8. For the purposes of its application to feeding stuffs the Act shall be modified as follows:—

- (a) in the definition of sampled portion in section 66(1) the words “five tonnes or 5000 litres” shall be substituted for the words “five tons or 1,000 gallons or the prescribed metric substitution”;
- (b) in section 68(2)(b) the words “to sales in quantities of not more than 25 kilograms” shall be substituted for the words “to sales of small quantities (that is to say, sales in quantities of not more than fifty six pounds or the prescribed metric substitution)”; and
- (c) in section 76(5) the words “six kilograms” shall be substituted for the words “fourteen pounds or the prescribed metric substitution”.

Sealed with the Official Seal of the Department of Agriculture on 19th October 1982.

(L.S.)

W. H. Parker

Assistant Secretary

SCHEDULE 1

Regulation 3

**MANNER OF TAKING, DIVIDING, MARKING, SEALING
AND FASTENING OF SAMPLES**

PART 1

DEFINITIONS

In this Schedule:—

“sampled portion” means a quantity of a material constituting a unit and having characteristics presumed to be uniform;

“incremental sample” means a quantity taken from one point in the sampled portion;

“aggregate sample” means an aggregate of incremental samples taken from the same sampled portion;

“reduced sample” means a representative part of the aggregate sample obtained from the latter by a process of reduction;

“final sample” means a representative part of the reduced sample or, where no intermediate reduction is required, of the aggregate sample; and

“unit” means a material identifiable as such by reason of its manufacturer, packer, uniform manner of packaging or labelling.

PART II

GENERAL INSTRUCTIONS FOR THE TAKING OF SAMPLES

1. In the case of feeding stuff in packages or containers, except where section 68(2)(b) of the Act applies, only unopened packages or containers which appear to the inspector proposing to take the sample to be the original packages or containers of the feeding stuff shall be selected for the purpose of the sample.

2. The sample shall be taken and prepared as quickly as possible having regard to the precautions necessary to ensure that it remains representative of the sampled portion. Instruments, surfaces and containers used in sampling shall be clean and dry.

3. No sample shall be drawn from any part of the sampled portion which appears to be damaged.

4. Where any appreciable portion of the feeding stuff appears to be mouldy, or is otherwise apparently unsuitable for feeding purposes, separate samples shall be drawn of the unsuitable portion and of the residue of the feeding stuff respectively. These shall be treated as separate sampled portions.

5. An inspector who intends to take a sample in accordance with the provisions of section 76(1)(b) of the Act on premises (not being premises used only as a dwelling) on which he has reasonable cause to believe that there is any feeding stuff which the occupier of the premises has purchased, shall:—

(a) satisfy himself that the conditions in which the feeding stuff is stored are not such as might cause undue deterioration of the said feeding stuff, and that the feeding stuff appears not to have been contaminated by any other material;

(b) where he has reasonable cause to believe that feeding stuff in packages or containers is only part of an original consignment, select the number of packages or containers to be sampled as if not less than the whole consignment were still present, except that sampling shall not take place if fewer than the minimum number of packages or containers prescribed in sub-paragraph 2(a) of Part III of this Schedule and in table 1 of Part VI for the purposes of paragraphs 2(c)(i) and 2(d)(i) of Part III of this Schedule are present.

The provisions of this paragraph shall not apply as respects any feeding stuff purchased for the purpose of resale in the course of trade.

6. The sampling apparatus shall be made of materials which cannot contaminate the feeding stuffs to be sampled.

7. In the case of a sampling spear its dimensions shall be appropriate to the characteristics of the sampled portion in all respects including dimensions of the container and particle size of the feeding stuff.

8. Notwithstanding the provisions of these regulations, a sampling spear shall not be used if, prior to the taking of a sample, objection is raised thereto by the manufacturer on the ground that the material is unsuitable.

9. Mechanical apparatus may be used for the sampling of moving feeding stuffs, provided that such equipment is capable of taking samples right across the flow of the product.

10. Apparatus designed to divide the sample into approximately equal parts may be used for taking incremental samples and for the preparation of reduced and final samples.

11. A sample taken according to the methods described below shall be considered as representative of the sampled portion.

PART III

QUANTITATIVE REQUIREMENTS

1. Sampled Portion

The sampled portion in compliance with regulation 2 shall be such that each of its constituent parts can be sampled in accordance with the requirements of this Schedule.

2. Incremental Sample

The incremental samples shall be selected in the following manner:—

- (a) in the case of pet foods in packages or containers where it appears to the inspector that to open the packages or containers and remove part or all of their contents may affect the composition or impede the proper analysis or other appropriate examination of the contents, the number of packages shall be selected in accordance with the following table:—

<i>Number of packages or containers in the sampled portion</i>	<i>Number to be selected for sampling</i>
12 to 144	not less than 12
145 to 256	not less than 16
257 and above	not less than 20

Provided that when the circumstances set out in section 77(2) of the Act are applicable the number of packages selected as incremental samples shall not be less than 16;

- (b) in the case of feed blocks or mineral licks, a number of blocks or licks shall be selected in accordance with the following table:—

<i>Number of blocks or mineral licks in the sampled portion</i>	<i>Number to be selected for sampling</i>
1 to 25	not less than 1
26 to 50	not less than 2
51 to 75	not less than 3
76 or more	not less than 4

(c) in relation to the control of undesirable substances likely to be distributed non-uniformly (a) in feeding stuffs other than compound feeding stuffs:—

- (i) in the case of feeding stuffs in packages the number of packages shall be selected in accordance with table 1 of Part VI of this Schedule;
 - (ii) in the case of loose feeding stuffs the number of incremental samples shall be selected in accordance with table 2 of Part VI of this Schedule; and
- (d) in respect of any feeding stuffs other than those mentioned in sub-paragraphs (a), (b) and (c) above:—
- (i) in the case of feeding stuffs in packages or containers, the number of packages or containers shall be selected in accordance with table 1 of Part VI of this Schedule, except that—

(a) the number of packages or containers need not exceed 20,

(b) where the contents of the package or container do not exceed 1 kg, or 1 litre, the number of packages or containers selected shall be not less than 4;

- (ii) in the case of loose feeding stuffs the number of incremental samples shall be selected in accordance with table 2 of Part VI of this Schedule.

3. Aggregate Sample

(a) In respect of any feeding stuffs other than those mentioned in sub-paragraph (b) a single aggregate sample per sampled portion is required. The weight or volume, as appropriate, of the aggregate sample shall be not less than the following:—

- (i) packaged feeding stuffs
 - (a) packages of more than 1 kg 4 kg
 - (b) packages not exceeding 1 kg 2 kg
 - (ii) loose feeding stuffs 4 kg
 - (iii) liquid or semi-liquid feeding stuffs
 - (a) containers of more than 1 litre 4 litres
 - (b) containers not exceeding 1 litre 2 litres
 - (iv) feed blocks or mineral licks
 - (a) feed block or mineral lick of more than 1 kg 4 kg
 - (b) feed block or mineral lick not exceeding 1 kg 2 kg
- (b) in relation to the control of undesirable substances likely to be distributed non-uniformly (a) in feeding stuffs other than compound feeding stuffs the weight of the aggregate sample shall be not less than 4 kg.

4. Final Sample

The amount of material in each final sample shall be not less than 500g in the case of solid feeding stuffs or 500ml in the case of liquid or semi-liquid feeding stuffs.

PART IV

TAKING AND PREPARATION OF SAMPLES

A. All feeding stuffs with the exception of those referred to under B of this Part of the Schedule.

1. Incremental samples

Incremental samples of approximately equal sizes shall be taken at random throughout the whole sampled portion in the following manner:—

- (a) in the case of packaged feeding stuffs to which paragraph 2(d)(i) of Part III of this Schedule applies—

(a) Such as aflatoxins, rye ergot, castor-oil plant and crotalaria.

- (i) the required number of packages having been selected, part of the content of each selected package shall be taken as the incremental sample;
 - (ii) where necessary, each selected package shall be emptied and worked up with a shovel separately, and one shovelful taken as the incremental sample;
 - (iii) when the material is of a suitable nature the incremental sample may be taken from each selected package by means of a sampling spear or by divider;
 - (iv) where the feeding stuff is in the state of small lumps or meal, the sample shall be taken in accordance with paragraph (ii) or (iii) of this sub-paragraph;
 - (v) where the feeding stuff consists of particles of grossly differing sizes the incremental sample shall be taken in accordance with paragraph (ii) of this sub-paragraph. Any lumps shall be crushed (and for this purpose may be separated from other material) and the whole then thoroughly remixed;
 - (vi) when the material is so packed or of such a nature that a shovel or spear or divider cannot be used, or where the content of the package does not exceed 1 kg, the whole package shall be taken as the incremental sample;
- (b) in the case of pet foods in packages or containers where the unopened packages or containers have been selected in accordance with sub-paragraph 2(a) of Part III of this Schedule, they shall be taken as the incremental samples;
- (c) in the case of loose feeding stuffs—
- (i) an imaginary division shall be made of the sampled portion into a number of approximately equal parts, corresponding to the number of incremental samples required in accordance with paragraph 2(d)(ii) of Part III of this Schedule, and an equal number of incremental samples shall be taken at random from each of these parts;
 - (ii) when sampling is being carried out while the material comprising the sampled portion is in motion, the incremental samples shall be taken from the randomly selected parts as required in paragraph (i) of this sub-paragraph;
 - (iii) when a sampling spear is used the sample shall be taken at an angle to the base of the heap;
 - (iv) where the feeding stuff consists of particles of grossly differing sizes the incremental samples shall be taken and treated in accordance with the relevant provisions of paragraph 1(a)(v);
- (d) in the case of feed blocks and mineral licks the number of blocks or licks to be selected shall be taken in accordance with sub-paragraph 2(b) of Part III of this Schedule. Where the block or lick does not weigh more than 1 kg, the whole block or lick shall be taken as the incremental sample; otherwise, sufficient shall be taken in any manner to give the aggregate sample, approximately equal portions being taken from each block;
- (e) in the case of liquid or semi-liquid feeding stuff in containers the number of containers to be selected shall be taken in accordance with paragraph 2(d)(i) of Part III of this Schedule, and
- (i) where the containers each contain not more than 1 litre the entire contents of the selected containers shall be transferred into a clean dry vessel of suitable material;
 - (ii) where the containers each contain more than 1 litre and not more than 200 litres—
 - (a) if the liquid is homogenisable the selected containers shall be well shaken or the contents agitated or otherwise treated to ensure uniformity. An approximately equal proportion of fluid shall then be taken immediately from each of the selected containers and transferred into a clean dry vessel of suitable material; but

- (b) if the liquid is non-homogenisable or if the inspector considers that the procedure in sub-paragraph (a) may not be appropriate, the contents shall be sampled by lowering an open tube (which must be long enough to reach the bottom of the container) perpendicularly, into the container. One or both ends of the tube shall be closed and the contents transferred into a clean dry vessel of suitable material. If sampling by tube is impracticable, portions shall be taken from various levels of the container with a sampling bottle so as to obtain a quantity fairly representative of the whole. An approximately equal proportion of fluid shall be taken from each container. The appropriate process shall be repeated until a total quantity of not less than 10 litres has been withdrawn;
- (iii) in the case of liquid or semi-liquid feeding stuff in containers each containing more than 200 litres—
- (a) when a consignment is being withdrawn from the container and there is a tap in the outlet pipe from which it is suitable to draw a sample, a quantity of not less than 4 litres shall be drawn from the tap (after first withdrawing sufficient to remove any residues in the pipe) into a clean dry vessel of suitable material, made up of portions of not less than 0.5 litre and of approximately equal size taken at regular intervals; otherwise
- (b) if the liquid is homogeneous, not less than 4 litres shall be drawn from a convenient outlet in the container (after first withdrawing sufficient to remove any residues in the outlet) into a clean dry vessel of suitable material; or
- (c) if the liquid is homogenisable it shall be well stirred or otherwise agitated; sampling shall then proceed as in sub-paragraph (b); but
- (d) if the liquid is non-homogenisable or if the inspector considers that the procedure in sub-paragraphs (a), (b) and (c) may not be appropriate, the contents shall be sampled as in sub-paragraph (ii)(b). The appropriate process shall be repeated until a total quantity of not less than 10 litres has been withdrawn;
- (e) where a sampled portion consists of two or more containers, incremental samples of approximately equal size shall be taken from each, drawn in the manner described in sub-paragraphs (a), (b), (c) or (d), as appropriate, until a quantity of not less than 4 or 10 litres has been withdrawn.

2. Aggregate sample

Except in the case of unopened packages or containers to which sub-paragraph 1(b) of this Part of this Schedule applies, the incremental samples shall be thoroughly mixed to form a single aggregate sample. In the case of solid feeding stuff, the material in the aggregate sample shall be carefully mixed to obtain an homogenised sample. Any lumps inconsistent with the nature of the material shall be broken up (if need be by separating them out and returning them to the aggregate sample). In the case of feed blocks and mineral licks not exceeding 1 kg the incremental samples shall be crushed or otherwise broken up and then thoroughly mixed to form a single aggregate sample.

3. Reduced sample

- (a) In the case of solid feeding stuff except where sub-paragraph (d) applies, the aggregate sample shall, if necessary, be reduced to not less than 2 kg in the following manner:—
- (i) the material shall be heaped to form a "cone" which shall then be flattened and quartered. Two diagonally opposite quarters shall be rejected, and the remainder shall then be mixed and the quartering and rejection continued as necessary; or
- (ii) a reduction method effected by the use of a mechanical device;

- (b) in the case of liquid or semi-liquid feeding stuff except where sub-paragraph (d) applies:—
- (i) where the aggregate sample consists of approximately 2 litres, it shall be taken as the final sample;
 - (ii) in all other cases, the aggregate sample shall be thoroughly mixed and a quantity of at least 2 litres transferred immediately into a clean dry vessel of suitable material;
- (c) in the case of feed blocks and mineral licks, the aggregate sample shall, if necessary, be reduced to not less than 2 kg in the manner described in sub-paragraph (a);
- (d) in the case of pet foods in unopened packages or containers to which sub-paragraph 1(b) of this Part of this Schedule applies the incremental samples shall be taken as the reduced sample.

4. Final samples

The final samples shall be obtained in the following manner:—

- (a) in the case of solid feeding stuff, including feed blocks and mineral licks, the reduced sample, or where necessary the aggregate sample, shall be thoroughly mixed and divided into three or, in the circumstances set out in section 77(2) of the Act, four similar and approximately equal parts and each part placed in an appropriate airtight container;
- (b) in the case of liquid or semi-liquid feeding stuff, the reduced sample, or where necessary the aggregate sample, shall be thoroughly mixed and at once divided into three or, in the circumstances set out in section 77(2) of the Act, four similar and approximately equal parts by pouring successive portions into appropriate airtight containers;
- (c) in the case of feeding stuff to which sub-paragraph 1(b) of this Part of this Schedule applies the reduced sample shall be randomly divided into three, or, in the circumstances set out in section 77(2) of the Act, four parts. Each part, which shall consist of the same number of unopened packages or containers, shall be placed in an appropriate container.

The containers used shall be such that the characteristics of the feeding stuff at the time of sampling are preserved.

B. In relation to the control of undesirable substances likely to be distributed non-uniformly(a) in feeding stuffs other than compound feeding stuffs

5. When samples are taken to determine the presence of undesirable substances likely to be distributed non-uniformly(a) in feeding stuffs other than compound feeding stuffs, the inspector is required to obtain a number of separate aggregate samples from the sampled portion from which separate final samples are to be obtained. The minimum number of aggregate samples per sampled portion shall be as follows:—

- (a) in the case of feeding stuffs in packages—

<i>Number of packages in the sampled portion</i>	<i>Number of separate aggregate samples required per sampled portion</i>
1 to 16	Not less than 1
17 to 200	Not less than 2
201 to 800	Not less than 3
More than 800	Not less than 4

- (b) in the case of loose feeding stuffs—

<i>Size of the sampled portion in tonnes</i>	<i>Number of separate aggregate samples required per sampled portion</i>
Up to and including 1	Not less than 1
Greater than 1 and up to and including 10	Not less than 2
Greater than 10 and up to and including 40	Not less than 3
Greater than 40	Not less than 4

(a) Such as aflatoxins, rye ergot, castor-oil plant and crotalaria.

6. (a) The number of incremental samples determined in accordance with sub-paragraph 2(c) of Part III of this Schedule shall be divided; if necessary, by the required number of aggregate samples determined in accordance with paragraph 5. If necessary, the resultant figure shall be rounded up to the next whole number.
- (b) The sampled portion shall be divided into approximately equal parts, if necessary, the number of parts being equal to the number of aggregate samples determined in accordance with paragraph 5.
- (c) The number of incremental samples determined in sub-paragraph (a) shall be taken at random from each of the parts determined in accordance with sub-paragraph (b) in the appropriate manner described in A of this Part of this Schedule.
- (d) The incremental samples taken from one part shall not be mixed with the incremental samples from another part. Final samples shall be taken from each of the parts in the appropriate manner described in A of this Part of this Schedule.

PART V

MARKING, SEALING AND FASTENING OF THE FINAL SAMPLE

1. Each container of a final sample shall be so secured and sealed by the person taking the sample that the container cannot be opened without breaking the seal; alternatively the container may be placed in a stout envelope or in a linen, cotton or plastic bag, and this further receptacle then secured and sealed in such a manner that the contents cannot be removed without breaking the seal or the receptacle.
2. A label shall be attached to the container or receptacle containing the final sample and sealed in such a manner that it cannot be removed without the seal being broken. The label shall be marked with the following particulars, which shall be visible without the seal being broken:—
 - (a) name of the inspector and the authority to which he belongs;
 - (b) identification mark given by the inspector to the sample;
 - (c) place of sampling;
 - (d) date of sampling;
 - (e) name of the material; and
 - (f) identification code, batch reference number or consignment identification of the material sampled, where readily available.
3. The container or receptacle may also be sealed, or the label also signed or initialled, by the holder of the material sampled or person acting on his behalf.

PART VI
SAMPLING TABLES

TABLE 1
PACKAGED FEEDING STUFFS

<i>Number of packages or containers in the sampled portion</i>	<i>Number of packages or containers to be selected</i>
1 to 4	All packages or containers not less than 4
5 to 16	4
17 to 25	5
26 to 36	6
37 to 49	7
50 to 64	8
65 to 81	9
82 to 100	10
101 to 121	11
122 to 144	12
145 to 169	13
170 to 196	14
197 to 225	15
226 to 256	16
257 to 289	17
290 to 324	18
325 to 361	19
362 to 400	20
401 to 441	21
442 to 484	22
485 to 529	23
530 to 576	24
577 to 625	25
626 to 676	26
677 to 729	27
730 to 784	28
785 to 841	29
842 to 900	30
901 to 961	31
962 to 1024	32
1025 to 1089	33
1090 to 1156	34
1157 to 1225	35
1226 to 1296	36
1297 to 1369	37
1370 to 1444	38
1445 to 1521	39
1522 and above	40

TABLE 2

LOOSE FEEDING STUFFS

<i>Size of sampled portion in tonnes</i>		<i>Number of incremental samples required</i>	
Up to and including 2.5		not less than	7
Greater than 2.5 and up to and including 3		"	8
" 3	" 4	"	9
" 4	" 5	"	10
" 5	" 6	"	11
" 6	" 7	"	12
" 7	" 8	"	13
" 8	" 9	"	14
" 9	" 11	"	15
" 11	" 12	"	16
" 12	" 14	"	17
" 14	" 16	"	18
" 16	" 18	"	19
" 18	" 20	"	20
" 20	" 22	"	21
" 22	" 24	"	22
" 24	" 26	"	23
" 26	" 28	"	24
" 28	" 31	"	25
" 31	" 33	"	26
" 33	" 36	"	27
" 36	" 39	"	28
" 39	" 42	"	29
" 42	" 45	"	30
" 45	" 48	"	31
" 48	" 51	"	32
" 51	" 54	"	33
" 54	" 57	"	34
" 57	" 61	"	35
" 61	" 64	"	36
" 64	" 68	"	37
" 68	" 72	"	38
" 72	" 76	"	39
" 76	"	"	40

METHODS OF ANALYSIS**1. General**

- (a) In general a single method of analysis is established for the determination of each substance in feeding stuffs. Where two or more methods are prescribed the choice shall, except where otherwise indicated, be left to the agricultural analyst concerned; the method used must however be indicated in the certificate of analysis.
- (b) The result given in the analysis report shall be the average value obtained from at least two independent determinations, carried out on separate portions of the sample, and of satisfactory repeatability.
- (c) The result shall be expressed in the manner laid down in the method of analysis to an appropriate number of significant figures and shall be corrected, if necessary, to the moisture content of the final sample prior to preparation (see paragraph 4 of Method 1).

2. Reagents and Apparatus

- (a) Unless otherwise specified in the methods of analysis, all reagents must be analytically pure. The purity of the reagents, especially when determining trace elements, must be checked by a blank test. Depending upon the results obtained, further purification of the reagents may be required.
- (b) As a general rule, water should be demineralized or distilled. In particular cases, which are indicated in the methods of analysis, it must be submitted to special procedures of purification.
- (c) Any operation involving preparation of solutions, dilution, rinsing or washing, mentioned in the methods of analysis without indication as to the nature of the solvent or diluent employed implies that water must be used.
- (d) Only those instruments or apparatus requiring special standards are mentioned in the descriptions of the methods of analysis. All instruments or apparatus used must be clean, especially when very small amounts of substances have to be determined.

3. Methods of Analysis

- 1. Preparation of sample for analysis
- 2. Moisture
- 3. a. Oil—in the presence of milk powder
- b. Oil—in the absence of milk powder
- 4. Protein
- 5. Urea
- 6. Uric acid
- 7. Ammonia and Volatile Nitrogenous Bases
- 8. Phosphorus
- 9. Fibre
- 10. a. Sugar—Luff-Schoorl method
- b. Sugar—Lane and Eynon method
- 11. Lactose
- 12. Ash
- 13. Ash insoluble in hydrochloric acid
- 14. Water-soluble chlorides
- 15. a. Calcium—volumetric method
- b. Calcium—atomic absorption method
- 16. Copper—diethyldithiocarbamate spectrophotometric method
- 17. Iron, Copper, Manganese and Zinc
- 18. a. Magnesium—gravimetric method
- b. Magnesium—atomic absorption
- 19. Vitamin A (retinol)
- 20. Thiamine hydrochloride (vitamin B₁, aneurine)

21. Ascorbic acid and dehydroascorbic acid (vitamin C)
22. Menadione (vitamin K₃)
23. Hydrocyanic acid
24. Volatile mustard oil
25. Free and total gossypol
26. a. Aflatoxin B₁—for certain straight feeding stuffs
b. Aflatoxin B₁—for all other feeding stuffs
27. Carbonates
28. Sodium
29. Urease activity
30. a. Starch—polarimetric method
b. Starch—pancreatic method
31. Proteins soluble in pepsin and hydrochloric acid
32. Pepsin activity
33. Moisture in fats and oils
34. Isobutylidenediurea

1. PREPARATION OF THE SAMPLE FOR ANALYSIS

1. Samples must be prepared in such a way that the amounts weighed out, as provided for in the methods of analysis, are homogeneous and representative of the final samples.

2. All the necessary operations must be performed in such a way as to avoid, as far as possible, any change in, or contamination of, the sample. Grinding, mixing and sieving should be carried out as quickly as possible with minimal exposure of the sample to the air and light. Avoid any overgrinding. Mills and grinders likely to heat the sample appreciably should not be used. Nevertheless, where some loss or gain of moisture is unavoidable, allowance should be made for such changes (see paragraph 4). Manual grinding is recommended for feeding stuffs which are particularly sensitive to heat. Care should also be taken to ensure that the apparatus itself is not a source of contamination by trace elements.

3. If the final sample as received consists of unopened packages or containers then immediately prior to the preparation of the sample for analysis the whole contents shall be thoroughly mixed together.

4. If the sample is appreciably moist or if for any reason the preparation cannot be carried out without significant changes in the moisture content of the sample, determine the moisture content before and after preparation using method 2.

5. When a microscopic examination for the presence of undesirable substances is required, it is recommended that the sample is crushed and ground only to such an extent that facilitates the examination. Grinding to pass 1mm may lead to difficulties in identifying the undesirable substances listed in Schedule 5 of the Feeding Stuffs Regulations 1982(a).

6. Procedure

Mix the sample thoroughly either mechanically or manually. Divide the sample into two equal portions (the quartering method should be used where applicable). Preliminary crushing and/or grinding may be necessary if the sample is in a coarse condition to facilitate this division. Keep one of the portions in a suitable container i.e. non-corrodible, clean and dry, fitted with an air-tight stopper and prepare the other portion or a representative part of it, of at least 100g, as indicated below.

6.1 Feeding stuffs which can be ground as such

Unless otherwise specified in the methods of analysis sieve the whole sample through a sieve having apertures of 1mm square⁽¹⁾(²), after grinding, if necessary.

Mix the sieved sample and collect it in a suitable container i.e. non-corrodible, clean and dry fitted with an air-tight stopper. Mix again, immediately before weighing out the amounts for analysis.

6.2 Feeding stuffs which can be ground only after drying

Unless otherwise specified in the methods of analysis dry the sample until grinding enables the sample to be passed wholly through a sieve having apertures of 1mm square⁽¹⁾(²). Then proceed as indicated in 6.1.

6.3 Liquid or semi-liquid feeding stuffs

Collect the sample in a suitable container i.e. non-corrodible, clean and dry, fitted with an air-tight stopper. Mix thoroughly immediately before weighing out the amount for analysis.

6.4 Other feeding stuffs

Samples which cannot be prepared according to one of the above procedures should be treated by any other procedure which ensures that the amounts weighed out for analysis are homogeneous and representative of the final samples.

7. Storage of samples

The samples must be stored at such a temperature as will minimise compositional changes. Samples intended for the analysis of vitamins or substances which are particularly sensitive to light should be placed in brown glass containers.

2. MOISTURE

1. Scope and Field of Application

This method is for the determination of moisture in feeding stuffs; it is not applicable to pet foods containing more than 14% moisture.

2. Principle

The sample is dried to constant weight in an oven at 100° C. The loss in weight corresponds to the moisture content of the sample.

3. Apparatus

- 3.1 Suitable containers with lids ensuring air-tight closure; the dimensions should allow the sample to be spread at about 0.3g per cm².
- 3.2 Electrically heated oven, suitably ventilated and capable of being maintained at 100±1° C.

4. Procedure

Weigh to the nearest 0.001g, approximately 5g of the prepared sample and transfer to a previously weighed container (3.1). Place the uncovered container and the lid in the oven (3.2) for 2 to 3 hours. Replace the lid on the container, remove from the oven and allow to cool in a desiccator and weigh. Reheat for another hour, cool and reweigh. If the difference in weight exceeds 0.010g continue the heating and cooling procedure until a weight constant within 0.002g is attained.

5. Expression of the Results

Calculate the total loss of weight and express it as a percentage of the original weight.

⁽¹⁾ Test sieves conforming to British Standard 410:1976 are suitable.

⁽²⁾ Where an analysis for copper has to be carried out, a stainless steel sieve should be used.

3a. OIL—IN THE PRESENCE OF MILK POWDER

1. Scope and Field of Application

This method is for the determination of oil in milk powders, including oil or fat fortified milk powders, and also for feeding stuffs containing milk powder and/or oil or fat fortified milk powder; it is not applicable to pet foods.

2. Principle

The sample is suspended in water, alcohol and ammonia added and the oil is extracted with a mixture of diethyl ether and light petroleum. The mixed solvent is distilled off and the residue dried and weighed.

3. Reagents

- 3.1 Ammonia solution ($d=0.88\text{g/ml}$).
- 3.2 Diethyl ether, peroxide free.
- 3.3 Ethanol 95% (V/V).
- 3.4 Light petroleum, boiling range 40–60° C.

4. Apparatus

Fat extraction tube ⁽¹⁾ provided with a glass stopper and siphon tube.

5. Procedure

Weigh to the nearest 0.001g, approximately 1g of the prepared sample and transfer to the extraction tube (4.).

Add 9ml water, temperature 60–70° C, stopper the tube and shake vigorously until the sample is uniformly suspended. Cool to room temperature, add 1.5ml ammonia solution (3.1), stopper and shake thoroughly. Add 10ml ethanol (3.3) using some to rinse the stopper and collect the washings in the extraction tube. Stopper the tube and shake thoroughly. Add 25ml diethyl ether (3.2) using some to wash the stopper as before, stopper the tube and shake vigorously for 90 seconds. Cool the tube and remove the stopper cautiously so as to avoid loss of contents. Add 25ml light petroleum (3.4), washing the stopper as before, stopper the tube and shake vigorously for 90 seconds. Centrifuge or allow to stand so that the solvent layer separates cleanly. Remove the stopper, insert a siphon tube and transfer the ether layer to a flask. Raise the siphon and, before removing it from the tube, wash it down with 15ml of diethyl ether (3.2). Remove the siphon tube and rinse the tip with ether, collecting the rinsings in the flask. Add 1ml ethanol (3.3) to the tube, stopper, shake vigorously for 90 seconds, cool, remove the stopper, add 15ml light petroleum (3.4) and again shake for 90 seconds. Allow to stand for 15 minutes or until the solvent layer separates cleanly, fit the siphon tube and remove the solvent layer to the flask as before.

Carry out a third extraction with 15ml diethyl ether (3.2) followed by 15ml light petroleum (3.4) in the same way, collecting the solvent in the flask. Remove the solvent from the flask by evaporation and dry the flask lying on its side at 100° C for 2 hours; cool in a desiccator and weigh. Reheat at 100° C for 30 minutes, cool and weigh. The second weight should not differ by more than 0.002g from the first weight. Add about 20ml light petroleum (3.4) to the flask and swirl gently to dissolve the oil, warming if necessary. Allow any residue to settle, then decant the supernatant solution taking care to retain any insoluble residue. Add another 20ml light petroleum (3.4) swirl cautiously and decant as before. Repeat with further small quantities of light petroleum, until all the oil has been removed from the flask. Reheat the flask, lying on its side, at 100° C for 1 hour, allow to cool and weigh.

6. Expression of the Results

The oil content of the sample is calculated from the weight of extract soluble in light petroleum expressed as a percentage of the weight of the test portion.

⁽¹⁾ British Standard 1743:1968, fig. 1 is suitable.

3b. OIL—IN THE ABSENCE OF MILK POWDER

1. Scope and Field of Application

This method is for the determination of oil in feeding stuffs not containing milk powder or fat fortified milk powder; it is not applicable to pet foods.

2. Principle

The sample is extracted with light petroleum and the solvent is distilled off and the extract dried and weighed.

3. Reagent

Light petroleum with a boiling range of 40–60° C. The bromine value should be less than 1 and the residue on evaporation less than 2mg/100ml.

4. Apparatus

4.1 Extraction apparatus: if fitted with a siphon (soxhlet apparatus), the reflux rate should be such as to produce about 10 cycles per hour; if of the non-siphoning type, the reflux rate should be about 10ml per minute.

4.2 Extraction thimbles: these should be free of matter soluble in light petroleum and should be of a porosity consistent with the requirements of 4.1.

4.3 Drying oven: either a vacuum oven set at $75 \pm 3^\circ$ C or an air-oven set at $100 \pm 3^\circ$ C.

5. Procedure

Weigh to the nearest 0.001g, between 3 and 5g of the prepared sample, transfer it to an extraction thimble (4.2) and cover with a fat-free wad of cotton wool. Place the thimble in an extractor (4.1) and extract for six hours with light petroleum (3.). Collect the light petroleum extract in a dry, weighed, flask containing fragments of pumice stone.

Distil off the solvent and dry the evaporation residue for one and a half hours in the drying oven (4.3). Cool in a desiccator and weigh. Dry again for 30 minutes to ensure that the weight of the oils and fats remains constant (loss in weight must be less than 1 mg).

6. Expression of Result

Express the result as a percentage of the sample.

4. PROTEIN

1. Scope and Field of Application

This method is for the determination of protein in feeding stuffs by the Kjeldahl method for nitrogen.

2. Principle

The sample is digested by mineral acid. The acidic solution is made alkaline by a sodium hydroxide solution. The ammonia released is removed by distillation and collected in a measured quantity of sulphuric acid, the excess of which is titrated with a solution of sodium hydroxide.

3. Reagents

3.1 Catalyst: mercuric oxide.

3.2 Potassium sulphate or anhydrous sodium sulphate.

3.3 Sucrose.

3.4 Zinc, granulated.

3.5 Pumice stone, granulated, washed in hydrochloric acid and ignited.

3.6 Sulphuric acid ($d=1.84$ g/ml).

- 3.7 Sodium hydroxide solution, carbonate free: dissolve 400g sodium hydroxide in water and dilute to 1,000ml.
- 3.8 Sodium sulphide, cold saturated solution.
- 3.9 Sodium thiosulphate solution: 8g sodium thiosulphate ($\text{Na}_2\text{S}_2\text{O}_3 \cdot 5\text{H}_2\text{O}$) per 100ml.
- 3.10 Sodium hydroxide solution, 0.1N.
- 3.11 Sodium hydroxide solution, 0.25N.
- 3.12 Sulphuric acid solution, 0.1N.
- 3.13 Sulphuric acid solution, 0.5N.
- 3.14 Methyl red indicator solution: dissolve 0.3g methyl red in 100ml of ethanol (95–96% V/V).
- 3.15 Screened methyl red indicator solution:
 - (a) dissolve 0.2g methyl red in 100ml of ethanol (95–96% V/V).
 - (b) dissolve 0.1g methylene blue in 100ml of ethanol (95–96% V/V).Mix one volume of (a) with one volume of (b).

4. Apparatus

Apparatus for mineral acid digestion and distillation according to Kjeldahl's method.

5. Procedure

5.1 Mineral acid digestion

Weigh to the nearest 0.001g, approximately 1g of the prepared sample, and transfer to a Kjeldahl Flask. Add 10g potassium sulphate (3.2) or sodium sulphate (3.2), 0.6 to 0.7g mercuric oxide (3.1), 25ml sulphuric acid (3.6) and a few grains of pumice stone (3.5). Mix. Heat the flask moderately at first, shaking from time to time, until the mass is carbonised and the froth has disappeared; then increase the heat and bring the liquid to a steady boil. Avoid overheating the walls which may cause organic particles to stick to the sides of the flask. When the solution appears clear and colourless continue boiling for a further 2 hours. Then allow to cool.

NOTE: If after the digestion and cooling crystallisation occurs repeat the analysis. If crystallisation still occurs, repeat the analysis using a larger quantity of sulphuric acid.

5.2 Distillation

Add 250–350ml water carefully mixing the contents during the addition; allow to cool. Then add a few pieces of zinc (3.4).

Transfer 25.0ml 0.1N (3.12) or 0.5N sulphuric acid (3.13) to the collecting flask of the distillation apparatus, according to the presumed level of nitrogen and a few drops of methyl red indicator (3.14) or (3.15).

Taking precautions against loss of ammonia, carefully add 100ml sodium hydroxide solution (3.7) and then add either 10ml sodium sulphide solution (3.8) or 25ml sodium thiosulphate solution (3.9). Mix well and connect immediately to the distillation apparatus.

Heat the flask so that approximately 150ml of the liquid is distilled in 30 minutes. At the end of this time, check the pH of the resulting distillate with indicator paper. If the reaction is alkaline, continue the distillation. Discontinue distillation when the distillate appears neutral to indicator paper. During the distilling process, swirl the contents of the collecting flask from time to time.

NOTE: If the contents of the collecting flask become alkaline, the determination should be abandoned and the analysis repeated making appropriate adjustments.

5.3 Titration

In the collecting flask titrate the excess sulphuric acid with sodium hydroxide solution 0.1N (3.10) or 0.25N (3.11), according to the normality of the sulphuric acid employed, to the end point of the indicator, (3.14) or (3.15).

5.4 Blank Test

Carry out a blank test on the reagents using 1g sucrose in place of the sample, and allow for this in the calculation of the results.

6. Expression of the Results

Determine the volume of sulphuric acid consumed. 1ml 0.1N sulphuric acid \equiv 1.4 mg nitrogen.

Calculate the percentage of nitrogen in the sample and convert to percentage protein by multiplying the result by 6.25.

NOTE: Where it is believed that the sample contains nitrogen in the form of ammoniacal or nitrate nitrogen, the appropriate determination should be made (Method 7) and the amount so obtained deducted from the total nitrogen content. Except in the case of compound feeding stuffs for ruminants, where it is believed that the sample contains nitrogen in the form of urea nitrogen or urea phosphate, uric acid nitrogen, biuret nitrogen or 1, 1-isobutylidenediurea nitrogen, the amount of nitrogen contributed by these ingredients should be determined and deducted from the total nitrogen content (Methods 5, 6 and 34).

5. UREA

1. Scope and Field of Application

This method is for the determination of urea in feeding stuffs.

2. Principle

The sample is suspended in water with a clarifying agent and filtered. The urea content of the filtrate is determined after the addition of 4-dimethylaminobenzaldehyde (4-DMAB) by measuring the absorbance at 435nm.

3. Reagents

- 3.1 Activated charcoal.
- 3.2 Carrez solution I: dissolve 21.9g of zinc acetate dihydrate in water, add 3ml of glacial acetic acid and dilute to 100ml with water.
- 3.3 Carrez solution II: 10.6g potassium ferrocyanide per 100ml.
- 3.4 Hydrochloric acid 0.02N.
- 3.5 Sodium acetate solution: 136g sodium acetate trihydrate per 1,000ml.
- 3.6 14-dimethylaminobenzaldehyde solution: dissolve 1.6g of 4-dimethylaminobenzaldehyde (4-DMAB) in 100ml of 96% ethanol and add 10ml of hydrochloric acid ($d=1.18\text{g/ml}$).
- 3.7 Urea standard solution: 0.1g urea per 100ml.

4. Apparatus

- 4.1 Rotary shaker.
- 4.2 Spectrophotometer with 10mm cells.

5. Procedure

5.1 Dissolution of sample

Weigh to the nearest 0.001g, approximately 2g of the prepared sample or a suitable amount expected to contain between 50 and 200mg of urea, and transfer to a 500ml graduated flask. Add 150ml 0.02N hydrochloric acid (3.4) shake for 30 minutes then add 10ml sodium acetate solution (3.5) and mix well. Add 1g activated charcoal (3.1) to the flask and shake well and stand for a further 15 minutes. Add 5ml Carrez solution I (3.2), followed by 5ml Carrez solution II (3.3), mixing well between additions. Dilute to volume with water and mix well. Filter a portion through a dry filter paper into a clean, dry 250ml beaker.

5.2 Determination

Transfer 10ml of the filtrate to a ground-glass stoppered test tube, add 10ml of 4-DMAB solution (3.6) mix and allow to stand for 15 minutes. Measure the absorbance of the solution at 435nm, in a 10mm cell, against a reference solution prepared from the reagents.

5.3 Calibration curve

Dilute 5, 10, 20, 30 and 40ml of the urea solution (3.7) to 100ml with water. Transfer 10ml of each solution to ground-glass stoppered test tubes and add 10ml of 4-DMAB solution (3.6) to each. Mix and allow to stand for 15 minutes. Measure the absorbance at a wavelength of 435nm in a 10mm cell against a reference solution prepared by mixing 10ml of 4-DMAB solution (3.6) with 10ml water. Construct a graph relating the absorbances to the amounts of urea present.

6. Expression of Results

Determine the amount of urea in the sample by reference to the calibration curve. Express the result as a percentage of the sample. (% urea $\times 0.4665$ = % urea nitrogen).

NOTE: If the sample is highly coloured the proportion of activated charcoal must be increased up to 5g. The final solution after filtering should be colourless.

6. URIC ACID

1. Scope and Field of Application

This method is for the determination of uric acid and its salts in dried poultry waste and in feeding stuffs containing dried poultry waste.

2. Principle

Uric acid is extracted with neutral ethanolic formaldehyde solution, precipitated as silver magnesium urate, redissolved in sodium thiosulphate solution and determined spectrophotometrically.

3. Reagents

3.1 Sodium hydroxide solution: dissolve 50g sodium hydroxide in 50ml water, mix well and store in a suitable plastic container.

3.2 Formaldehyde solution: the strength of the commercially available solution should be checked as follows: mix 3ml formaldehyde solution with 50ml 1N sodium hydroxide solution and 25ml hydrogen peroxide solution (20 volumes). Heat on a steam bath until effervescence stops. Cool, and titrate with 1N hydrochloric acid using phenolphthalein indicator. Carry out a blank titration using 3ml water in place of the formaldehyde.

1ml of 1N sodium hydroxide $\equiv 0.0300$ g formaldehyde

strength of formaldehyde solution $\equiv (B-T) \times \frac{0.0300 \times 100}{3}$ g per 100ml

where B = blank titre; and

T = sample titre.

3.3 Neutral ethanolic formaldehyde solution: mix an appropriate volume of formaldehyde solution (3.2) containing 17.5g of formaldehyde with 250ml water and 500ml ethanol. Adjust the pH of the solution to 7.0 with 0.1N sodium hydroxide solution. Dilute to 1,000ml with water, mix and again adjust the pH to 7.0 if necessary.

3.4 Succinate buffer solution: dissolve by heating, 29.5g of succinic acid in 750ml water and 20ml sodium hydroxide solution (3.1). Cool, add an appropriate volume of formaldehyde solution (3.2) containing 17.5g of formaldehyde, mix well and adjust the pH to 6.0 with sodium hydroxide solution (3.1). Dilute to 1,000ml with water, mix and again adjust the pH to 6.0 if necessary.

3.5 Sodium thiosulphate solution: 25g sodium thiosulphate ($\text{Na}_2\text{S}_2\text{O}_3 \cdot 5\text{H}_2\text{O}$) per 1,000ml.

- 3.6 Silver lactate solution: dissolve, by heating, 3g silver lactate in 50ml water and 1ml lactic acid. Dilute to 100ml with water, filter, and store in dark glassware. Do not expose to strong light.
- 3.7 Ammoniacal magnesium solution: dissolve 8.75g magnesium sulphate ($\text{MgSO}_4 \cdot 7\text{H}_2\text{O}$) and 17.5g ammonium chloride in 50ml water. Add 30ml ammonia solution ($d=0.88$ g/ml) mix well and dilute to 100ml with water.
- 3.8 Benedict and Hitchcock reagent: mix 35ml silver lactate solution (3.6) with 15ml ammoniacal magnesium solution (3.7). Add 50ml ammonia solution ($d=0.88$ g/ml). Mix well. Prepare *immediately* before use.
- 3.9 Standard uric acid solution: weigh to the nearest 0.1mg, 250mg of uric acid and transfer to a 150ml round-bottomed flask fitted with a reflux condenser. Add 100ml ethanolic formaldehyde solution (3.3) and boil under reflux on a steam bath for 30 minutes, shaking frequently. Cool, transfer the solution to a 250ml graduated flask, wash the round-bottomed flask with ethanolic formaldehyde solution (3.3) and combine the washings with the uric acid solution. Dilute to the mark with ethanolic formaldehyde solution (3.3) and mix. 1ml contains 1mg of uric acid.
- 3.10 Light petroleum, boiling range 40-60° C.

4. Apparatus

- 4.1 Spectrophotometer, with 10mm silica cells.
- 4.2 Percolation tubes, glass. Upper part: approximately 240mm long, 18mm internal diameter; lower part: approximately 120mm long, 8mm internal diameter.

5. Procedure

5.1 *Extraction of Uric Acid*

5.1.1 *From dried poultry waste:*

Weigh to the nearest 0.001g, about 0.4g dried poultry waste and place in a 150ml round-bottomed flask. Add 60ml ethanolic formaldehyde solution (3.3), fit a reflux condenser onto the flask and heat on a steam bath for 1 hour. Cool and filter by suction through a sintered glass crucible (porosity 4) into a 100ml graduated flask. Wash out the round-bottomed flask with 3×10ml portions of ethanolic formaldehyde solution (3.3) passing each portion through the crucible into the graduated flask. Dilute to 100ml with ethanolic formaldehyde solution and mix.

5.1.2 *From feeding stuffs:*

Weigh to the nearest 0.001g, between 4g and 5g of prepared sample. Transfer to a glass percolation tube (4.2) fitted with a small paper cup to retain the feed. Remove the fat from the feed by extraction with light petroleum (3.10). Transfer quantitatively the defatted sample to a 150ml round-bottomed flask and remove the residual solvent with a slow current of air. Continue as in 5.1.1, second sentence "... Add 60ml ethanolic formaldehyde solution (3.3). ...".

5.2. *Determination*

Transfer by pipette 20ml of the sample extract prepared as in 5.1.1 or 5.1.2 to a 50ml centrifuge tube. Add 10ml of Benedict and Hitchcock reagent (3.8), mix well and allow to stand in the dark for 1 hour. Centrifuge at 2,000 rpm for 15 minutes, pour off the supernatant liquid and allow to drain for 10 minutes. Carefully wipe off any remaining liquid without disturbing the precipitate, and add 20ml sodium thiosulphate solution (3.5) to each tube. Dissolve the precipitate by stirring with a thin glass rod. Transfer by pipette 5ml of this solution into a 200ml graduated flask containing 40ml succinate buffer solution (3.4). Dilute to 200ml with water and mix well. Measure the absorbance of the solution at 294nm in 10mm silica cells against a solution prepared by mixing 5ml sodium thiosulphate solution (3.5) with 40ml succinate buffer solution (3.4) and diluting to 200ml with water. Determine the quantity of uric acid present by reference to the calibration curve (5.3).

5.3 Calibration Curve

Into a series of 50ml centrifuge tubes, transfer by pipette 2, 4, 6, 8, 10 and 12ml standard uric acid solution (3.9) (corresponding to 2, 4, 6, 8, 10 and 12mg of uric acid) and make up to 20ml with ethanolic formaldehyde solution (3.3). Add to each tube 10ml Benedict and Hitchcock reagent (3.8), mix well and stand in the dark for 1 hour. Continue as in 5:2 from "... Centrifuge at 2,000 rpm. . .". Measure the absorbances of the solutions and plot the calibration curve using absorbances as the ordinates and the corresponding quantities of uric acid, in mg (as shown above) as the abscissae.

6. Expression of the Results

The uric acid nitrogen content per cent of the sample is given by the formula:

$$\frac{A}{6 \times W}$$

where:

A = mg uric acid (in the aliquot volume of the sample extract) as determined by photometric measurement; and

W = weight of sample in grams.

7. AMMONIA AND VOLATILE NITROGENOUS BASES

1. Scope and Field of Application

This method is to be used for those feeding stuffs for which a declaration of protein content is required and which are believed to contain ammoniacal nitrogen (see NOTE to Method 4). It is also to be used for those products listed in Schedule 2 of the Feeding Stuffs Regulations 1982 for which a declaration in terms of volatile nitrogenous bases may be given.

2. Principle

Ammonia and other nitrogenous bases are liberated from an aqueous extract of the sample by alkaline hydrolysis, displaced from solution by a stream of air at room temperature and collected in sulphuric acid solution, excess of which is titrated with sodium hydroxide.

3. Reagents

3.1 Sulphuric acid solution, 0.1N.

3.2 Sodium hydroxide solution, 0.1N.

3.3 Potassium carbonate, saturated solution.

3.4 Screened methyl red indicator solution:

(a) dissolve 0.2g methyl red in 100ml of ethanol (95—96% V/V)

(b) dissolve 0.1g methylene blue in 100ml of ethanol (95—96% V/V)

Mix one volume of (a) with one volume of (b).

3.5 Octan-1-ol.

4. Apparatus

4.1 An example of the recommended apparatus is shown in fig. 1. The apparatus is made up of a specially shaped reaction vessel (A) with a ground-glass neck, a side neck, a connecting tube (C) with a splash head leading into a conical flask (D) and a perpendicular tube (B) for the introduction of air. Alternatively the tubes can be connected to the reaction vessel by means of a simple perforated rubber bung. It is important to give a suitable shape to the end of the tubes introducing air, since the bubbles of gas must be evenly distributed throughout the solutions contained in the vessel and the absorber. The best arrangement consists of small mushroom-shaped pieces with an external diameter of 20mm and six openings of 1mm around the periphery.

4.2 Rotary shaker, 35-40 turns per minute.

5. Procedure

Weigh to the nearest 0.001g, approximately 5g of the prepared sample and transfer to a 250ml graduated flask. Add water to the mark and shake the flask and contents for 10 minutes on the rotary shaker (4.2) to dissolve the soluble salts. Filter the aqueous extract collecting the filtrate in a clean flask. Transfer by pipette to the dry reaction flask a portion of the filtrate containing a maximum of 20mg ammoniacal nitrogen. Connect up the apparatus. Place 50.0ml standard sulphuric acid (3.1) in the 500ml conical flask (D), add a few drops of indicator and sufficient distilled water so that the level of the liquid is 50mm above the opening of the delivery tube. Introduce through the side neck of the reaction vessel distilled water to bring the volume up to 50ml; add a few drops of octan-1-ol (3.5) to prevent foaming during aeration. Add 50ml saturated potassium carbonate solution (3.3), close the side tube to prevent loss of ammonia. Pass a current of air through the system (3,000ml per minute). The air should be purified by passing it through washing flasks containing dilute sulphuric acid and dilute sodium hydroxide. Ammonia should be completely liberated in 3 hours. Disconnect the conical flask (D) and rinse the delivery end of the apparatus and the sides of the conical flask (D) with distilled water. Titrate the excess acid with standard 0.1N sodium hydroxide (3.2). Carry out a blank determination omitting only the sample.

6. Expression of the Results

The amount of ammoniacal nitrogen, as a percentage of the sample, is given by:

$$\frac{(a-A) \times 0.14}{W}$$

where:

a = blank titre, ml;

A = sample titre, ml; and

W = weight of sample extract in grams, present in the aliquot part taken for analysis.

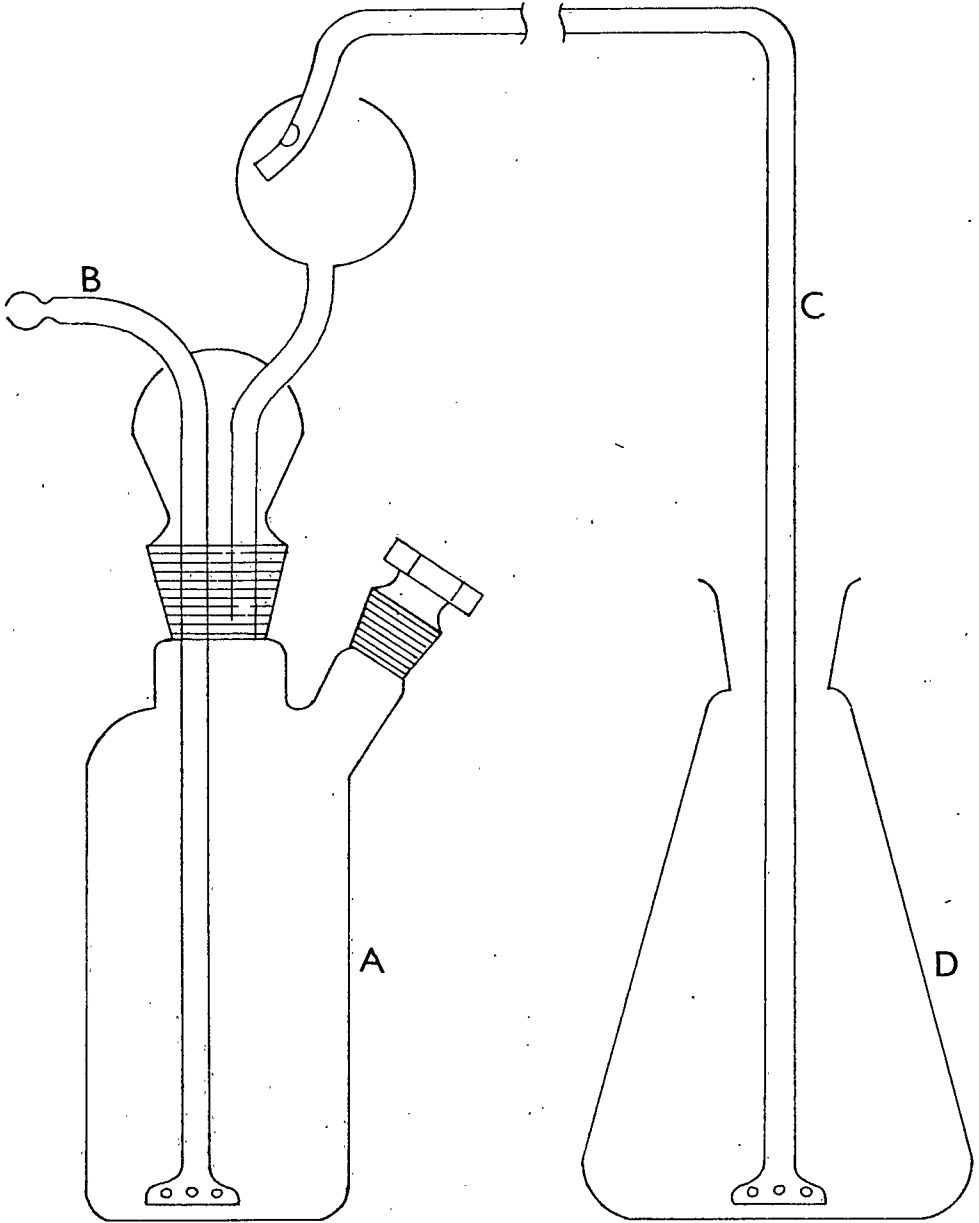

Fig. 1

- A = Reaction vessel, 350-400ml capacity.
- B = Tube for introduction of air.
- C = Delivery tube with splash head.
- D = Conical Flask, 500ml capacity.

8. PHOSPHORUS

1. Scope and Field of Application

This method is for the determination of total phosphorus in feeding stuffs.

2. Principle

The sample is either ashed (in the case of organic feeding stuffs) or digested with acid (in the case of mineral compounds and liquid feeding stuffs). An acidic solution is treated with molybdovanadate reagent and the absorbance of the yellow solution is measured at 430nm.

3. Reagents

- 3.1 Calcium carbonate.
- 3.2 Nitric acid ($d=1.42\text{g/ml}$).
- 3.3 Sulphuric acid ($d=1.84\text{g/ml}$).
- 3.4 Hydrochloric acid, 50% (V/V): dilute an appropriate volume of hydrochloric acid ($d=1.18\text{g/ml}$) with an equal volume of water.
- 3.5 Nitric acid, 10% (V/V): dilute 10ml of nitric acid (3.2) to 100ml with water.
- 3.6 Molybdovanadate reagent: dissolve separately 20g of ammonium molybdate $[(\text{NH}_4)_6\text{Mo}_7\text{O}_{24} \cdot 4\text{H}_2\text{O}]$ and 0.47g of ammonium vanadate in water, mix, acidify with 140ml of nitric acid (3.2) and dilute to 1,000ml.
- 3.7 Phosphorus standard solution: dissolve 4.387g of potassium dihydrogen phosphate, previously dried at 105°C for 1 hour, in water and dilute to 1,000ml. 1ml=1mg phosphorus (P).

4. Apparatus

- 4.1 Muffle furnace capable of being maintained at $550 \pm 5^\circ\text{C}$.
- 4.2 Spectrophotometer with 10mm cells.

5. Procedure

5.1 *Dissolution of the sample*

According to the nature of the sample, prepare a solution as indicated in either 5.1.1 or 5.1.2.

5.1.1 *For samples containing organic feeding stuffs free from calcium and magnesium phosphates:*

Weigh to the nearest 0.001g, approximately 2.5g of the prepared sample and transfer to a silica or porcelain crucible. Add 1g of calcium carbonate (3.1), mix well and incinerate at $550 \pm 5^\circ\text{C}$ until a white or grey ash is obtained. Allow to cool, transfer the ash quantitatively to a 250ml beaker, add 20ml of water and sufficient hydrochloric acid (3.4) until effervescence ceases, taking suitable precautions to avoid loss. Add a further 10ml of hydrochloric acid (3.4) and evaporate to dryness to make the silica insoluble. Cool, treat the residue with 10ml of nitric acid (3.5), and boil for five minutes, avoid evaporating to dryness. Transfer the solution to a 500ml graduated flask, rinsing the beaker several times with hot water. Cool to room temperature, make up to volume with water, mix and filter.

5.1.2 *Alternative procedure, especially suitable for mineral compounds and liquid feeding stuffs:*

Weigh to the nearest 0.001g, approximately 1g of the prepared sample and transfer to a Kjeldahl flask. Add 20ml of sulphuric acid (3.3), shake to break up the sample and to prevent it sticking to the sides of the flask. Boil for ten minutes, allow to cool, add 2ml of nitric acid (3.2) and bring back to boiling point. Repeat the procedure of addition of nitric acid until a colourless solution is obtained. Cool, cautiously add a small volume of water and transfer the solution to a 500ml graduated flask, rinsing the Kjeldahl flask with hot water. Cool to room temperature, make up to volume with water, mix and filter.

5.2 Determination

Dilute, if necessary, the filtrate as obtained in 5.1.1 or 5.1.2 in order to obtain a phosphorus concentration of not more than $40\mu\text{g/ml}$. Transfer 10ml of this solution to a glass-stoppered test tube, add 10ml of freshly prepared molybdovanadate reagent (3.6) and mix. Allow to stand for ten minutes at 20°C , and then measure the absorbance at 430nm against a freshly prepared reference solution prepared by adding 10ml of molybdovanadate reagent (3.6) to 10ml of water.

5.3 Calibration curve

From the standard solution (3.7) prepare solutions containing respectively 5, 10, 20, 30 and $40\mu\text{g}$ of phosphorus per ml. Transfer 10ml of each of these solutions to glass-stoppered test tubes, add 10ml of molybdovanadate reagent, mix and proceed as in 5.2. Construct a graph relating the absorbances to the amount of phosphorus present. The calibration curve should be newly constructed, if possible, at the same time as the determination is carried out.

6. Expression of the Results

Determine the amount of phosphorus in the test sample by reference to the calibration curve. Express the result as a percentage of the sample.

9. FIBRE

1. Scope and Field of Application

This method is for the determination of the fibre content of feeding stuffs.

2. Principle

The sample is defatted and treated successively with boiling solutions of sulphuric acid and sodium hydroxide of specified concentrations. The residue is separated by filtration, washed, dried, weighed and ashed. The loss of weight resulting from ashing corresponds to the fibre present in the test sample.

3. Reagents

- 3.1 Sulphuric acid solution, 0.255N.
- 3.2 Sodium hydroxide solution, 0.313N: the solution must be free or nearly free from sodium carbonate.
- 3.3 Anti-foam agent (e.g. silicone).
- 3.4 Ethanol, 95% (V/V).
- 3.5 Diethyl ether.
- 3.6 Light petroleum, boiling range $40-60^\circ\text{C}$.
- 3.7 Hydrochloric acid: dilute 10ml of hydrochloric acid ($d=1.18\text{g/ml}$) with water to 1,000ml.

4. Apparatus

- 4.1 Conical flask, 1,000ml.
- 4.2 Buchner flask.
- 4.3 Buchner funnel.
- 4.4 Platinum or silica crucibles.
- 4.5 Electric muffle furnace.
- 4.6 Extraction apparatus, for removal of fatty material.

5. Procedure

Weigh to the nearest 0.001 g, between 2.7 and 3.0g of the prepared sample, transfer to the extraction apparatus (4.6) and extract with light petroleum (3.6). Alternatively, extract with light petroleum by stirring, settling and decanting three times. Air dry the extracted sample and transfer to a dry 1,000ml conical flask (4.1). Add 200ml of sulphuric acid (3.1), measured at ordinary temperature and brought to boiling point, the first 30 to 40ml being used to disperse the sample; heat to boiling point within 1 minute. An appropriate amount of anti-foam agent (3.3) may be added if necessary. Boil gently for exactly 30 minutes, maintaining a constant volume and rotating the flask every few minutes in order to mix the contents and remove particles from the sides.

Meantime fit a Buchner funnel with suitable filter paper. This should be of such quality that it does not release any paper fibre during washings⁽¹⁾ (it is convenient to use two filter papers, thereby facilitating the transfer of the insoluble matter at a later stage). Pour boiling water into the funnel, allow to remain until the funnel is hot and then drain by applying suction.

At the end of the 30 minutes boiling period, allow the acid mixture to stand for 1 minute and then pour immediately into a shallow layer of hot water under gentle suction in the prepared funnel. Adjust the suction so that the filtration of the bulk of the 200ml is completed within 10 minutes. Repeat the determination if this time is exceeded.

Wash the insoluble matter with boiling water until the washings are free from acid; then wash back into the original flask by means of a wash bottle containing 200ml 0.313N sodium hydroxide solution (3.2) measured at ordinary temperature and brought to boiling point. Boil for 30 minutes with the same precautions as those used in the earlier boiling and treatment. Allow to stand for 1 minute and then filter immediately through a suitable filter paper. Transfer the whole of the insoluble material to the filter paper by means of boiling water, wash first with boiling water then with dilute hydrochloric acid (3.7) and finally with boiling water until free from acid. Then wash twice with ethanol (3.4) and three times with diethyl ether (3.5). Transfer the insoluble matter to a dried, weighed, ashless filter paper⁽¹⁾ and dry at 100° C to a constant weight. Allow to cool in a desiccator and weigh. Transfer the paper and insoluble matter to a crucible (4.4) previously ignited to constant weight. Incinerate the paper and contents to an ash at a dull red heat to a constant weight. Allow to cool in a desiccator and weigh.

6. Expression of the Results

The fibre content, as a percentage of the sample, is given by the formula:

$$\frac{d - (p + a) \times 100}{W}$$

where:

d = weight of the paper + insoluble matter after drying (g);

p = weight of the paper (g);

a = weight of the ash (g); and

W = weight of sample (g).

NOTE: In the event of the sample containing 3% or more of calcium carbonate (chalk or limestone flour), it will be necessary to remove the calcium carbonate before digesting the sample with acid. This can be done at the stage in the procedure when the portion taken for analysis has been extracted with light petroleum. The original weight taken for the determination should be such that the actual amount of feeding stuff free from calcium carbonate is between 2.7 and 3.0g.

Transfer the air-dried extracted sample to a 1,000ml conical flask, add a quantity of hydrochloric acid (3.7) more than sufficient to neutralise the calcium carbonate present and stir well. Allow to settle, decant off the supernatant liquid through a filter and wash the residue twice by decantation with water, passing the washings through the filter. Allow the residue and the filter to drain thoroughly. Bring 200ml 0.255N sulphuric acid (3.1) (measured at ordinary temperature) to boiling point and use a portion of this to wash any particles on the filter back into the flask. Add the remainder of the acid to the flask and heat to boiling point within 1 minute. Add an appropriate amount of anti-foam agent (3.3) if necessary and continue the determination as described in 5; commencing "Boil gently for exactly 30 minutes, . . .".

(1) Whatman No. 541 or equivalent.

10a. SUGAR—LUFF-SCHOORL METHOD

1. Scope and Field of Application

This method is for the determination of glucose, reducing sugars expressed as glucose and total sugar expressed as sucrose in feeding stuffs.

2. Principle

The sugars are extracted either with aqueous ethanol or with water, the solution is clarified and the sugars are determined before and after inversion by the Luff-Schoorl method.

3. Reagents

- 3.1 Ethanol solution: 40% (V/V) neutralised to phenolphthalein.
- 3.2 Carrez solution I: dissolve 21.9g zinc acetate dihydrate in water, add 3ml glacial acetic acid and dilute to 100ml with water.
- 3.3 Carrez solution II: dissolve 10.6g potassium ferrocyanide in water and dilute to 100ml.
- 3.4 Methyl orange solution: 0.1g per 100ml.
- 3.5 Hydrochloric acid solution; 4N.
- 3.6 Hydrochloric acid solution, 0.1N.
- 3.7 Sodium hydroxide solution, 0.1N.
- 3.8 Luff-Schoorl reagent:
 - 3.8.1 Copper sulphate solution: dissolve 25g copper sulphate pentahydrate in water and dilute to 100ml.
 - 3.8.2 Citric acid solution: dissolve 50g citric acid monohydrate in water and dilute to 50ml.
 - 3.8.3 Sodium carbonate solution: dissolve 143.8g anhydrous sodium carbonate in approximately 300ml of warm water. Leave to cool. Stirring carefully, pour the citric acid solution (3.8.2) into the sodium carbonate solution (3.8.3). Add the copper sulphate solution (3.8.1) and make up to 1,000ml with water. Leave to settle overnight and then filter. Check the normality of the reagent thus obtained (Cu 0.1N; Na₂CO₃2N). The solution's pH should be approximately 9.4.
- 3.9 Sodium thiosulphate solution, 0.1N.
- 3.10 Starch solution: dissolve 5g soluble starch in 30ml water and add this to 1,000ml boiling water. Boil for 3 minutes, allow to cool and add 10mg mercuric iodide as preservative.
- 3.11 Sulphuric acid solution, 6N.
- 3.12 Potassium iodide solution: 30g per 100ml.
- 3.13 Granulated pumice stone boiled in hydrochloric acid, washed in water and dried.
- 3.14 3-methylbutan-1-ol.
- 3.15 Ethanol solution: 80% (V/V).

4. Apparatus

Rotary shaker, 35–40 turns per minute.

5. Procedure

5.1 *Extraction of the sample*

5.1.1 *All straight and compound feeding stuffs except those listed under 5.1.2 and 5.1.3*

Weigh, to the nearest 0.001g, approximately 2.5g of the prepared sample and transfer to a 250ml graduated flask. Add 200ml 40% ethanol (3.1) and mix on the rotary shaker (4.) for 1 hour. Add 5ml Carrez solution I (3.2) and stir for one minute. Add 5ml of Carrez solution II (3.3) and again stir for one minute. Make up to volume with

40% ethanol (3.1), mix and filter. Remove 200ml of the filtrate and evaporate to approximately half volume in order to eliminate most of the ethanol. Transfer the residue quantitatively to a 200ml graduated flask using warm water, cool, make up to volume with water, mix and filter if necessary. This solution is used to determine the amount of reducing sugars and, after inversion, of total sugars.

5.1.2 *Feeding stuffs rich in molasses and other feeding stuffs which are not particularly homogeneous*

Weigh, to the nearest 0.001g, approximately 20g of the prepared sample and place with 500ml water in a 1,000ml graduated flask. Mix for 1 hour on the rotary shaker (4.). Clarify using Carrez I (3.2) and II (3.3) reagents as described in 5.1.1, this time using four times the quantity of each reagent. Make up to volume with 80% ethanol (3.15), mix and filter. Proceed as described in 5.1.1 from "Remove 200ml of the filtrate. . .".

5.1.3 *Molasses and straight feeding stuffs which are rich in sugar and almost starch free*

Weigh, to the nearest 0.001g, approximately 5g of the prepared sample and place with 200ml water in a 250ml graduated flask. Mix for 1 hour, or more if necessary, on the rotary shaker (4.). Clarify using Carrez I (3.2) and II (3.3) reagents as described in 5.1.1. Make up to volume with water, mix and filter.

5.2 *Determination of reducing sugars*

If necessary, dilute the solution prepared in 5.1 so that 25ml contains less than 60mg reducing sugars, expressed as glucose. Determine the content of reducing sugars by the Luff-Schoorl method as in 5.4 below.

5.3 *Determination of total sugars after inversion*

Take 50ml of the solution prepared in 5.1 and transfer to a 100ml graduated flask and add a few drops of methyl orange solution (3.4). Carefully and stirring continuously, add hydrochloric acid (3.5) until the liquid turns a definite red. Add 15ml hydrochloric acid (3.6) and immerse the flask in a boiling water bath for thirty minutes. Cool rapidly to approximately 20° C and add 15ml sodium hydroxide solution (3.7). Make up to 100ml with water and mix. If necessary, dilute the solution so that 25ml contains less than 60mg reducing sugars expressed as glucose. Determine the content of reducing sugars by the Luff-Schoorl method as in 5.4 below.

5.4 *Titration by the Luff-Schoorl method*

Take 25.0ml of Luff-Schoorl reagent (3.8) and transfer to a 300ml Erlenmeyer flask and add 25.0ml of the clarified sugar solution from 5.2 or 5.3. Add 2 granules of pumice stone (3.13) and 1ml 3-methylbutan-1-ol (3.14), heat, while swirling by hand, over a free flame of medium height so as to bring the liquid to the boil in approximately two minutes. Place the flask immediately on an asbestos-coated wire gauze with a hole approximately 60mm in diameter, under which a flame has been lit. The flame shall be regulated in such a way that only the base of the flask is heated. Fit a reflux condenser to the Erlenmeyer flask and boil for exactly ten minutes. Cool immediately in cold water and after approximately five minutes titrate as below.

Add 10ml of potassium iodide solution (3.12) and immediately add 25ml of sulphuric acid (3.11) added carefully in small increments to prevent excessive foaming. Titrate with sodium thiosulphate solution (3.9) until a dull yellow colour appears; add the starch indicator (3.10) and complete the titration.

5.5 *Blank titration*

Carry out the same titration (without boiling) on a mixture of 25.0ml of Luff-Schoorl reagent (3.8) and 25ml of water, after adding 10ml of potassium iodide solution (3.12) and 25ml of sulphuric acid (3.11).

6. Expression of Results

Calculate the difference between the sample titration (5.4) and the blank titration (5.5) expressed in ml 0.1N sodium thiosulphate solution.

6.1 *Glucose and reducing sugars expressed as glucose*

From the table provided (7.) determine the amount of glucose (in mg) in the aliquot portion taken for the titration (5.2); interpolate where necessary.

Express the result as a percentage of the sample.

6.2 *Sucrose*

From the table provided (7.) determine the amount of glucose (in mg) in the aliquot portions taken for the titrations both before inversion (5.2) and after inversion (5.3); interpolate where necessary. The difference between the two values multiplied by 0.95 gives the amount of sucrose present.

Express the result as a percentage of the sample.

6.3 *Total sugars after inversion, expressed as sucrose*

From the table provided (7.) determine the amount of glucose (in mg) in the aliquot portion taken for the titration (5.3); interpolate where necessary. This value multiplied by 0.95 gives the amount of total sugar as sucrose.

Express the result as the percentage of the sample.

7. Table of Values for 25ml of Luff-Schoorl Reagent

The table gives the amount of glucose expressed in mg that is equivalent to the difference between the sample titre (5.4) and the blank titre (5.5) expressed in ml 0.1N sodium thiosulphate solution.

Sodium thiosulphate, 0.1N ml	Glucose mg
1	2.4
2	4.8
3	7.2
4	9.7
5	12.2
6	14.7
7	17.2
8	19.8
9	22.4
10	25.0
11	27.6
12	30.3
13	33.0
14	35.7
15	38.5
16	41.3
17	44.2
18	47.1
19	50.0
20	53.0
21	56.0
22	59.1
23	62.2

10b. SUGAR—LANE AND EYNON METHOD**1. Scope and Field of Application**

This method is for the determination of total sugar expressed as sucrose in feeding stuffs. It is not applicable to the determination of glucose and reducing sugars expressed as glucose. It shall not be used after 25th February 1984.

2. Principle

The sugar is extracted from the sample with water, the solution clarified and the total reducing sugar content is determined after inversion of the sucrose.

3. Reagents

3.1 Fehling's solution

3.1.1 Copper sulphate solution: dissolve 69.28g copper sulphate ($\text{CuSO}_4 \cdot 5\text{H}_2\text{O}$) in water and dilute to 1,000ml.

3.1.2 Potassium sodium tartrate solution: dissolve 346g potassium sodium tartrate and 100g sodium hydroxide in water and dilute to 1,000ml. For use, mix equal volumes of solutions 3.1.1 and 3.1.2.

NOTE: The strength of the Fehling's solution should be such that 10ml is equivalent to 0.0525g invert sugar. It should be checked as follows: dissolve 2.375g sucrose (dried at 100°C) in about 100ml water in a 300ml beaker, add 15ml hydrochloric acid (3.2) and sufficient water to give a volume of 150ml. Heat to boiling point, boil for 2 minutes; cool, add 2 or 3 drops of phenolphthalein indicator solution (3.8), just neutralise with sodium hydroxide solution (3.6) transfer to a 500ml graduated flask and dilute to 500ml. Then follow the procedure described in 4.2.3: 1ml of this solution \equiv 0.00475g sucrose \equiv 0.005g invert sugar, i.e. 10ml Fehling's solution \equiv 10.5ml of this standard invert sugar solution.

3.2 Hydrochloric acid solution, N.

3.3 Carrez solution I: dissolve 21.9g zinc acetate dihydrate in water, add 3ml glacial acetic acid and dilute to 100ml with water.

3.4 Carrez solution II: dissolve 10.6g potassium ferrocyanide in water and dilute to 100ml.

3.5 Potassium oxalate solution: dissolve 5g potassium oxalate in water and dilute to 100ml.

3.6 Sodium hydroxide solution: dissolve 10g sodium hydroxide in water and dilute to 100ml.

3.7 Methylene blue solution: dissolve 2.5g methylene blue in water and dilute to 250ml.

3.8 Phenolphthalein indicator solution: dissolve 0.25g phenolphthalein in 150ml industrial methylated spirit and dilute with water to 250ml.

4. Procedure

4.1 Extraction

4.1.1 Sample in solid form

Weigh to the nearest 0.01g, approximately 10g of the prepared sample, or a sufficient quantity to obtain about 2g sugar. Grind in a mortar with warm water at a temperature not exceeding 60°C and transfer to a 500ml graduated flask using about 400ml water. Shake the flask at intervals during 30 minutes. Add 5ml potassium oxalate solution (3.5) to the contents of the flask, followed by 5ml Carrez solution I (3.3), mix well and then add 5ml Carrez solution II (3.4) make up to the mark with water at room temperature, mix well and filter. Determine the sugar in 100ml of the filtrate by the procedure described in 4.2.

4.1.2 Sample in liquid form

Weigh to the nearest 0.001g, approximately 5g of the prepared sample and wash with water into a 250ml graduated flask, using about 200ml water. To clear the solution add 5ml Carrez solution I (3.3). Mix, then add 5ml Carrez solution II (3.4), again mix, dilute to the mark with water, mix and filter. Determine the sugar in 25ml of the filtrate by the method described in 4.2.

4.2 Determination

4.2.1 Inversion

Transfer the measured volume of filtrate obtained as described in 4.1.1 or 4.1.2 to a 300ml beaker add 15ml hydrochloric acid (3.2), dilute to 150ml with water, cover with a watch glass and heat to boiling point. Continue to boil for 2 minutes, cool, add 2 or 3 drops of phenolphthalein indicator solution (3.8), just neutralise with sodium hydroxide solution (3.6), transfer to a 200ml graduated flask and dilute to the mark. Filter if necessary.

4.2.2 Preliminary estimation

(This estimation is usually necessary where the percentage of sugar is unknown)

Transfer 10.0ml Fehling's solution (3.1) to a 250ml conical flask and add 20ml of water. Add from a burette approximately 10ml of the filtrate prepared as described in 4.2.1, heat to boiling point and boil briskly for 1 minute. Add 3 drops of methylene blue solution (3.7) and titrate from the burette at the rate of 1ml per 15 seconds until the blue colour is discharged, the contents of the flask being kept boiling throughout the titration. Note the total number of ml required, and call this x ml. This titration should not be outside the range of 15-40ml otherwise the determination should be repeated using a more appropriate volume of the filtrate.

4.2.3 Exact determination

To 10ml Fehling's solution (3.1) in a 250ml conical flask add from a burette $(x-1)$ ml of the filtrate prepared as described in 4.2.1, together with sufficient water to make a total volume 60ml. Heat to boiling point, boil briskly for $1\frac{1}{2}$ minutes and add 3 drops of methylene blue solution (3.7). Titrate from the burette at the rate of approximately 0.25ml per 15 seconds until the blue colour is discharged, the contents of the flask being kept boiling briskly throughout the titration which must not take more than $1\frac{1}{2}$ minutes. The total number of ml used in the determination equals the sugar equivalent of 10ml Fehling's solution.

10ml Fehling's solution \equiv 0.0525g invert sugar.

Not more than 1ml of filtrate should be required for the completion of the titration. If more than 1ml is required, then the determination should be repeated, using a more closely calculated volume of filtrate for the original addition. The time taken from the initial boiling point until the end of the titration should be about 3 minutes. If this time is exceeded by more than 20 seconds, the titration should be repeated.

5. Expression of the Results

The total copper reducing power should be calculated as invert sugar and multiplied by 0.95 to give the sugar content.

11. LACTOSE

1. Scope and Field of Application

This method is for the determination of lactose in feeding stuffs containing more than 0.5% lactose.

2. Principle

The sugars are extracted from the sample with water and subjected to fermentation by the yeast *Saccharomyces cerevisiae*. The solution is clarified and filtered and the lactose content of the filtrate is determined by the Luff-Schoorl method.

3. Reagents

- 3.1 *Saccharomyces cerevisiae* suspension: suspend 25g of fresh yeast in 100ml water. This suspension will keep for 1 week if stored in a refrigerator.

- 3.2 Carrez solution I: dissolve 21.9g zinc acetate dihydrate in water, add 3ml glacial acetic acid and dilute to 100ml with water.
- 3.3 Carrez solution II: dissolve 10.6g potassium ferrocyanide in water and dilute to 100ml.
- 3.4 Luff-Schoorl reagent:
 - 3.4.1 Copper sulphate solution: dissolve 25g copper sulphate pentahydrate in water and dilute to 100ml.
 - 3.4.2 Citric acid solution: dissolve 50g citric acid monohydrate in water and dilute to 50ml.
 - 3.4.3 Sodium carbonate solution: dissolve 143.8g anhydrous sodium carbonate in approximately 300ml of warm water. Leave to cool. Stirring carefully, pour the citric acid solution (3.4.2) into the sodium carbonate solution (3.4.3). Add the copper sulphate solution (3.4.1) and make up to 1,000ml with water. Leave to settle overnight and then filter. Check the normality of the reagent thus obtained (Cu 0.1N; Na₂CO₃ 2N). The solution's pH should be approximately 9.4.
- 3.5 Granulated pumice stone, boiled in hydrochloric acid, washed in water and dried.
- 3.6 Potassium iodide solution: 20g per 100ml.
- 3.7 Sulphuric acid solution, 6N.
- 3.8 Sodium thiosulphate solution, 0.1N.
- 3.9 Starch solution: dissolve 5g soluble starch in 30ml water and add this to 1,000ml boiling water. Boil for 3 minutes, allow to cool and add 10mg mercuric iodide as preservative.

4. Apparatus

Water bath.

5. Procedure

5.1 Preparation of the solution

Weigh, to the nearest 0.001g, approximately 1g of the sample and transfer to a 100ml graduated flask. Add 25-30ml water. Place the flask in a boiling water bath (4.) for 30 minutes and then cool to approximately 35° C. Add 5ml yeast suspension (3.1) (see NOTE), mix and maintain the flask at 38-40° C for 2 hours. Cool to approximately 20° C. Add 2.5ml Carrez solution I (3.2), stir for 30 seconds, then add 2.5ml Carrez solution II (3.3) and again stir for 30 seconds. Make up to 100ml with water, mix and filter. Transfer by pipette into a 300ml Erlenmeyer flask a suitable volume of filtrate not exceeding 25ml and containing from 40 to 80mg lactose. If necessary make up to 25ml with water.

NOTE: If the sample contains more than 40% fermentable sugar, increase the amount of yeast suspension (3.1) used accordingly.

5.2 Reagent blank

Carry out a blank test on the reagents following the procedure in 5.1, but omitting the sample.

5.3 Determination

Determine the lactose content of the prepared solution, using the Luff-Schoorl method, as follows:

Transfer 25.0ml of Luff-Schoorl reagent (3.4) to the flask containing the sample solution and add 2 granules of pumice stone (3.5). Heat, while swirling by hand, over a free flame of medium height so as to bring the liquid to the boil in approximately 2 minutes. Place the flask immediately on an asbestos-coated wire gauze with a hole approximately 60mm in diameter, under which a flame has been lit. The flame should be regulated in such a way as to heat only the base of the flask. Fit a reflux condenser to the Erlenmeyer flask and boil for exactly 10 minutes. Cool immediately in cold water and after approximately 5 minutes titrate as below.

Add 10ml potassium iodide solution (3.6) and immediately add 25ml of sulphuric acid (3.7) (added carefully in stages to prevent excessive foaming). Titrate with sodium thiosulphate solution (3.8) until a dull yellow colour appears; then add the starch indicator (3.9) and complete the titration.

5.4 Blank titration

To a flask containing 10ml potassium iodide solution (3.6) and 25ml sulphuric acid (3.7) transfer 25.0ml of Luff-Schoorl reagent (3.4) and 25ml water. Titrate this solution as directed in 5.3, but without boiling.

6. Expression of Results

Calculate the difference between sample titration (5.3) and blank titration (5.4) expressed in ml of 0.1N sodium thiosulphate solution. Using the table provided (7.) and interpolating where necessary, determine the amount of lactose in the aliquot portion taken for titration, taking into account the reagent blank. Express the result as the percentage of lactose in the sample.

7. Table of Values for 25ml of Luff-Schoorl Reagent

The table gives the amount of lactose expressed in mg that is equivalent to the difference between the sample titre (5.3) and the blank titre (5.4) expressed in ml 0.1N sodium thiosulphate solution.

Sodium thiosulphate, 0.1N ml	Lactose mg
1	3.6
2	7.3
3	11.0
4	14.7
5	18.4
6	22.1
7	25.8
8	29.5
9	33.2
10	37.0
11	40.8
12	44.6
13	48.4
14	52.2
15	56.0
16	59.9
17	63.8
18	67.7
19	71.7
20	75.7
21	79.8
22	83.9
23	88.0

12. ASH

1. Scope and Field of Application

This method is for the determination of the ash content of feeding stuffs.

2. Principle

The sample is ashed at 550° C; the residue is weighed.

3. Reagents

Ammonium nitrate solution: 20g ammonium nitrate per 100ml.

4. Apparatus

- 4.1 Hot-plate.
- 4.2 Muffle furnace capable of being maintained at $550 \pm 5^\circ \text{C}$.
- 4.3 Crucibles for ashing made of platinum or an alloy of platinum and gold (10% Pt, 90% Au), either rectangular ($60 \times 40 \times 25\text{mm}$) or circular (diameter: 60 to 75mm, height: 20 to 25mm).

5. Procedure

Weigh to the nearest 0.001g, approximately 5g of the prepared sample (2.5g in the case of products which have a tendency to swell) and place in a crucible for ashing which has first been heated at 550°C , cooled in a desiccator and weighed. Either place the crucible in a cold muffle and bring up to a temperature of 550°C overnight, or carbonise the contents of the crucible before placing in the hot muffle. Keep at this temperature until white, light grey or reddish ash is obtained which appears to be free from carbonaceous particles. Place the crucible in a desiccator, allow to cool and weigh.

6. Expression of Results

Calculate the weight of the residue and express the result as a percentage of the sample.

7. Observations

- 7.1 Substances which are difficult to ash must be subjected to an initial ashing of at least three hours, cooled and then a few drops of ammonium nitrate solution (3.) added to it (carefully, to avoid dispersal of the ash or the formation of lumps). Dry in an oven at 100°C and then incinerate at 550°C . Repeat the operation as necessary until ashing is complete.
- 7.2 In the case of substances resistant to the treatment described under 7.1, proceed as follows: after ashing for three hours, place the ash in warm water and filter through a small, ash-free filter. Ash the filter and its contents in the original crucible. Place the filtrate in the cooled crucible, evaporate until dry, ash and weigh.
- 7.3 In the case of oils and fats, weigh accurately a sample of approximately 25g in a suitably sized crucible. Carbonise by setting light to the substance with a strip of ash-free filter paper. After combustion, moisten with as little water as possible. Dry and ash as described in 5.

13. ASH INSOLUBLE IN HYDROCHLORIC ACID

1. Scope and Field of Application

This method is for the determination of hydrochloric acid-insoluble mineral substances in feeding stuffs. Two methods can be used, according to the nature of the sample.

- 1.1 Method A: applicable to feeding stuffs composed predominantly of organic substances.
- 1.2 Method B: applicable to feeding stuffs composed predominantly of mineral substances and including those whose hydrochloric acid-insoluble portion, as determined by method A, is greater than 1%.

2. Principle

- 2.1 Method A: the sample is ashed, boiled in hydrochloric acid and the insoluble residue filtered and weighed.
- 2.2 Method B: the sample is treated with hydrochloric acid and the resulting solution is filtered. The residue is ashed and then treated as in method A.

3. Reagents

- 3.1 Hydrochloric acid solution, 3N.
- 3.2 Trichloroacetic acid solution, 20g per 100ml.
- 3.3 Trichloroacetic acid solution, 1g per 100ml.

4. Apparatus

- 4.1 Hot-plate.
- 4.2 Electric muffle furnace, with thermostat.
- 4.3 Crucibles for ashing: platinum or platinum and gold alloy (10% Pt, 90% Au), rectangular (60 × 40 × 25mm) or circular (diameter: 60 to 75mm, height: 20 to 25mm).

5. Procedure

5.1 Method A

Ash the sample using the method for the determination of ash (Method 12). Transfer the ash into a 250 to 400ml beaker using 75ml 3N hydrochloric acid (3.1) and evaporate to dryness. Continue heating for at least one hour to dehydrate any silica which may be present. Cool, add 75ml 3N hydrochloric acid (3.1), bring slowly to the boil and boil gently for 15 minutes. Filter the warm solution through an ash-free filter paper and wash the residue with warm water until the filtrate is no longer acid. Dry the filter containing the residue and ash in a tared crucible (4.3) at a temperature of not less than 550° C and not more than 700° C. Cool in a desiccator and weigh.

5.2 Method B

Weigh to the nearest 0.001g, approximately 5g of the prepared sample and transfer to a 250 to 400ml beaker. Add 25ml water and 25ml 3N hydrochloric acid (3.1) carefully, mix and wait for any release of gas to cease. Add a further 50ml of HCl 3N (3.1). Wait for any release of gas to cease then place the beaker in a boiling water bath for at least 30 minutes in order to hydrolyse thoroughly any starch which may be present. Filter the solution while still warm through an ash-free filter paper and wash the filter with 50ml warm water (see NOTE). Place the filter containing the residue in a tared crucible (4.3), dry and ash at a temperature of not less than 550° C and not more than 700° C.

Transfer the ash to a 250 to 400ml beaker using 75ml 3N hydrochloric acid (3.1). Continue as in 5.1 from “. . . Bring slowly to the boil and boil gently for 15 minutes . . .”.

NOTE: if filtration proves difficult, repeat the analysis, replacing the 50ml 3N hydrochloric acid (3.1) by 50ml trichloroacetic acid solution (3.2) and washing the filter in a warm solution of 1% trichloroacetic acid (3.3).

6. Expression of the Results

Calculate the weight of the residue and express the result as a percentage of the sample.

14. WATER-SOLUBLE CHLORIDES

1. Scope and Field of Application

This method is for the determination of the amount of water-soluble chloride expressed as sodium chloride. It is applicable to all feeding stuffs.

2. Principle

The sample is extracted with water and the solution clarified if necessary. The chloride is precipitated in acid solution with a known amount of standard silver nitrate solution and the excess of silver is titrated with standard thiocyanate solution, using ferric alum as indicator.

3. Reagents

- 3.1 Activated charcoal.
- 3.2 Acetone.
- 3.3 Diethyl ether.
- 3.4 Nitric acid ($d=1.42\text{g/ml}$).
- 3.5 Ammonium ferric sulphate, saturated solution.
- 3.6 Carrez solution I: dissolve 21.9g zinc acetate dihydrate in water, add 3ml glacial acetic acid. Make up to 100ml with water.
- 3.7 Carrez solution II: 10.6g potassium ferrocyanide per 100ml.
- 3.8 Ammonium thiocyanate solution, 0.1N, or potassium thiocyanate solution, 0.1N.
- 3.9 Silver nitrate solution, 0.1N.

4. Apparatus

Rotary shaker: approximately 35 to 40rpm.

5. Procedure

5.1 Preparation of the solution

According to the nature of the sample, prepare a solution as shown in 5.1.1, 5.1.2 or 5.1.3.

At the same time carry out a blank test omitting the sample to be analysed.

5.1.1 Samples free from organic matter

Weigh to the nearest 0.001g a portion of the prepared sample of not more than 10g and containing not more than 3g of chlorine in the form of chlorides. Place with 400ml of water in a 500ml graduated flask at approximately 20° C. Mix for 30 minutes in the rotary shaker (4.), bring up to volume, mix and filter.

5.1.2 Samples containing organic matter, excluding the products listed in 5.1.3

Weigh to the nearest 0.001g, approximately 5g of the prepared sample and place with 1g of activated charcoal (3.1) in a 500ml graduated flask. Add 400ml water at approximately 20° C, shake well and allow to stand for 30 minutes. Add 5ml Carrez solution I (3.6) mix well and then add 5ml Carrez solution II (3.7). Mix for 30 minutes in the rotary shaker (4.) make up to the mark, mix and filter.

5.1.3 Samples containing cooked feeding stuffs, linseed cakes and flour, products rich in linseed flour and other products rich in mucilage or in colloidal substances (for example, dextrinated starch)

Prepare the solution as described in 5.1.2 but do not filter. Decant (if necessary, centrifuge) and transfer 100ml of the supernatant liquid to a 200ml graduated flask. Mix with acetone (3.2) and bring up to the mark with this solvent, mix and filter.

5.2 Titration

Transfer to an Erlenmeyer flask from 25ml to 100ml of the filtrate (according to the presumed chlorine content) obtained as described in 5.1.1, 5.1.2 or 5.1.3. The aliquot portion must not contain more than 150mg of chlorine. Dilute if necessary to not less than 50ml with water, add 5ml nitric acid (3.4), 20ml saturated solution of ammonium ferric sulphate (3.5) and two drops of the thiocyanate solution (3.8) transferred by means of a burette filled up to the zero mark. Add from a burette the silver nitrate solution (3.9) in such a way that an excess of 5ml is obtained. Add 5ml of diethyl ether (3.3) and shake hard to coagulate the precipitate.

Titrate the excess silver nitrate with the thiocyanate solution (3.8), until the reddish-brown tint persists for one minute.

6. Expression of Results

The weight of chlorine in mg (W), expressed as sodium chloride, present in the volume of filtrate taken for titration is calculated by using the following formula:

$$[W = 5.845 \times (V_1 V_2)]$$

where:

V_1 = ml of silver nitrate solution, 0.1N added; and

V_2 = ml of ammonium thiocyanate solution, 0.1N or potassium thiocyanate solution, 0.1N, used for titration.

If the blank test indicates that silver nitrate solution, 0.1N has been consumed deduct this value from the volume ($V_1 - V_2$).

Express the result as a percentage of the sample.

15a. CALCIUM — VOLUMETRIC METHOD

1. Scope and Field of Application

This method is for the determination of the total calcium content of feeding stuffs.

2. Principle

The sample is ashed, the ash treated with hydrochloric acid and the calcium precipitated as calcium oxalate. The precipitate after filtering and washing is dissolved in acid and the liberated oxalic acid is titrated with standard potassium permanganate solution.

3. Reagents

- 3.1 Ammonia (d=0.88g/ml).
- 3.2 Hydrochloric acid solution, 50% (V/V): dilute an appropriate volume of concentrated hydrochloric acid (d=1.18g/ml) with an equal volume of water.
- 3.3 Nitric acid (d=1.42g/ml).
- 3.4 Ammonium chloride solution: 5g ammonium chloride per 100ml.
- 3.5 Ammonium oxalate, cold saturated solution.
- 3.6 Citric acid monohydrate solution: 30g citric acid monohydrate per 100ml.
- 3.7 Sulphuric acid solution, 20% (V/V): 20ml sulphuric acid (d=1.84g/ml) per 100ml.
- 3.8 Potassium permanganate solution, 0.1N:
- 3.9 Bromocresol green indicator solution: dissolve 0.04g of bromocresol green in 20ml ethanol and dilute to 100ml with water.

4. Apparatus

- 4.1 Muffle furnace capable of being maintained at 550° C.
- 4.2 Platinum, silica or porcelain crucibles for ashing.
- 4.3 Glass filter crucibles, No. 4 porosity.

5. Procedure

5.1 Dissolution of sample

Weigh to the nearest 0.001g, approximately 5g of the prepared sample into the crucible (4.2) and incinerate at a temperature not exceeding 550° C until all the organic matter has been destroyed. Allow to cool, moisten the ash with water and cautiously add 10ml of hydrochloric acid (3.2), avoiding loss by use of a cover glass. Wash the cover glass with water adding the washings to the crucible and evaporate to dryness. Continue the heating for at least one hour in order to dehydrate any silica that might be present. Cool, add 20ml water, 40ml of hydrochloric acid (3.2), bring to the boil and then filter into a 250ml graduated flask. Wash the crucible and filter with hot water collecting the washings in the flask. Cool, make up to the mark and mix.

5.2 Determination

Transfer an aliquot of the solution from 5.1 containing 10 to 40mg of calcium into a 250ml beaker, add 1ml of citric acid solution (3.6) and 5ml of ammonium chloride solution (3.4). Make the volume up to approximately 100ml with water, bring to the boil, add 8 to 10 drops of bromocresol green indicator solution (3.9) and 30ml of a warm solution of ammonium oxalate (3.5). If any precipitate forms dissolve it by adding a few drops of hydrochloric acid (3.2). Neutralise very slowly with ammonia (3.1), stirring continuously until a pH of 4.4–4.6 is obtained (i.e. when the indicator changes colour). Place the beaker on a steam bath and keep it there for 30 minutes to allow the precipitate, which has formed, to settle. Remove the beaker from the steam bath and allow it to stand for one hour. Transfer the precipitate to the glass filter crucible (4.3) with water and wash the beaker and the precipitate with water until the excess ammonium oxalate is removed. (The absence of chloride in the washing water indicates that they have been sufficiently washed). Rinse the outside of the glass filter crucible with water and discard the rinsings. Place the crucible containing the precipitate in the original 250ml beaker, add 50ml of sulphuric acid (3.7) and water to give a total volume of about 100ml and heat the contents to 70–80° C in order to dissolve the precipitate. Titrate the hot solution with potassium permanganate (3.8) until a pink colour persists for one minute.

6. Expression of the Results

1ml 0.1N potassium permanganate \equiv 2.004mg calcium. Express the result obtained as a percentage of the sample.

NOTE: where the magnesium content of the sample exceeds that of the calcium, the calcium oxalate should be re-dissolved and re-precipitated before titration with potassium permanganate.

15b. CALCIUM—ATOMIC ABSORPTION METHOD

1. Scope and Field of Application

This method is for the determination of the calcium content of feeding stuffs.

2. Principle

The sample is ashed, the ash treated with hydrochloric acid and dissolved in hydrochloric acid. The calcium content of the solution is determined by atomic absorption spectrophotometry in the presence of lanthanum salt. The lanthanum salt is added to eliminate the interference of other elements, (phosphorus, alkali metals).

3. Reagents

- 3.1 Hydrochloric acid ($d=1.18\text{g/ml}$).
- 3.2 Hydrochloric acid solution, 50% (V/V): dilute an appropriate volume of hydrochloric acid (3.1) with an equal volume of water.
- 3.3 Lanthanum oxide solution (releasing agent): moisten 117.3g lanthanum oxide (La_2O_3), low in calcium content, with water. Slowly add 350ml hydrochloric acid (3.1) and stir until all the lanthanum oxide is dissolved. Allow to cool and dilute to 1,000ml with water.
- 3.4.1 Calcium standard solution: dry calcium carbonate at 105° C for one hour. Weigh accurately 2.497g and transfer to a 1,000ml graduated flask using approximately 100ml water. Add slowly, while swirling, 60ml N hydrochloric acid (3.5). When all the carbonate has dissolved, make up to the mark with water. 1ml of this solution \equiv 1.00mg calcium (Ca).
- 3.4.2 Calcium standard solution (dilute): dilute 20ml of calcium standard solution (3.4.1) to 200ml with water. 1ml of this solution \equiv 100 μg calcium (Ca).
- 3.5 Hydrochloric acid solution, 1N.

4. Apparatus

- 4.1 Muffle furnace capable of being maintained at 550° C.
- 4.2 Platinum or silica crucibles for ashing.
- 4.3 Atomic absorption spectrophotometer with a calcium hollow cathode lamp.

5. Procedure

5.1 *Dissolution of sample*

Weigh to the nearest 0.001 g, approximately 5g of the prepared sample into a platinum or silica crucible (4.2), and ash at a temperature not exceeding 550° C until all the organic matter has been destroyed. Allow to cool, moisten the ash with water and cautiously add 10ml 50% (V/V) hydrochloric acid (3.2) avoiding loss by use of a cover glass. Wash the cover glass with water, adding the washings to the crucible and evaporate to dryness. Continue the heating for at least one hour to dehydrate any silica which may be present. Cool, add 20ml water and 10ml 50% (V/V) hydrochloric acid (3.2), bring to the boil and filter into a 250ml graduated flask. Wash the crucible and filter with hot water, collecting the washings in the flask. Cool, make up to volume and mix.

5.2 *Determination*

Set up the instrument using the line at a wavelength of 422.7nm. Use a fuel rich flame. Add releasing agent (3.3) and water to a suitable aliquot of the sample solution to produce a standard volume of solution to contain between 5 and 10µg of calcium per ml and 10% (V/V) releasing agent. Prepare a blank solution from which only the sample has been omitted. Spray water into the flame and zero the instrument. Spray successively in triplicate, the standard solution (5.3), sample and blank, washing the instrument through with water between each spraying. Determine the calcium content of the sample and blank solution by reference to the calibration curve (5.3) and from the difference between them calculate the calcium content of the sample.

5.3 *Calibration curve*

Add 10ml releasing agent (3.3) to each of six 100ml graduated flasks. Measure 0, 3, 6, 9, 12 and 15ml of dilute calcium solution (3.4.2) into flasks and dilute to 100ml with water. The flasks contain 0, 3, 6, 9, 12 and 15µg calcium per ml respectively. Carry out the measurements as indicated in 5.2. Plot the mean reading obtained for each standard solution against its calcium content.

6. Expression of the Results

Express the result as a percentage of the sample.

7. Observations

If no organic matter is present, the sample should be dissolved directly in hydrochloric acid. For products, such as calcium aluminium phosphates which are not readily soluble in acid, an alkaline fusion should be adopted as follows:

Mix the sample to be analysed in a platinum crucible with a mixture five times its weight, consisting of equal parts of potassium carbonate and sodium carbonate. Heat carefully until the mixture is completely fused. Cool and dissolve carefully in hydrochloric acid and proceed as in 5.1.

16. COPPER—DIETHYLDITHIOCARBAMATE SPECTRO- PHOTOMETRIC METHOD

1. Scope and Field of Application

This method is for the determination of copper in feeding stuffs.

NOTE: determination of copper may also be carried out by atomic absorption spectrophotometry (Method 17).

2. Principle

The sample is ashed and the residue treated with hydrochloric acid. Copper is extracted from the resulting solution as its diethyldithiocarbamate complex into carbon tetrachloride. The copper content is measured at 436nm, by reference to a calibration curve.

3. Reagents

The water used should be free from copper.

- 3.1 Carbon tetrachloride, redistilled.
- 3.2 Sodium diethyldithiocarbamate solution: dissolve 1g sodium diethyldithiocarbamate in water and dilute to 100ml. Filter the solution if it is not clear. The solution may be stored, protected from light, in a refrigerator but should not be used after seven days.
- 3.3 EDTA-citrate solution: dissolve 20g ammonium citrate and 5g of the disodium salt of ethylenediaminetetra-acetic acid (EDTA) in water and dilute to 100ml. To purify, add 0.1ml sodium diethyldithiocarbamate solution (3.2) and extract with carbon tetrachloride (3.1). Add a further quantity of sodium diethyldithiocarbamate solution (3.2) to ensure that it is in excess.
- 3.4 Ammonium hydroxide solution approximately 6N: this may be prepared by passing gaseous ammonia into water, or by purifying ammonia solution as described for the EDTA-citrate solution (3.3).
- 3.5 Sulphuric acid solution, 2N.
- 3.6 Hydrochloric acid solution, 50% (V/V): dilute an appropriate volume of hydrochloric acid ($d=1.18\text{g/ml}$) with an equal volume of water.
- 3.7 Hydrochloric acid solution, 2N.
- 3.8 Nitric acid solution, 30% (V/V): dilute 30ml of nitric acid ($d=1.42\text{g/ml}$) with water to 100ml.
- 3.9 Copper standard solution: weigh to the nearest 0.1mg, 393mg of copper sulphate ($\text{CuSO}_4 \cdot 5\text{H}_2\text{O}$), dissolve in 100ml 2N sulphuric acid (3.5) and dilute to 1,000ml with water.
- 3.10 Copper standard working solution: dilute 5ml of the copper sulphate standard solution (3.9) to 250ml with 2N sulphuric acid (3.5) immediately before use. 1 ml of this solution $\equiv 2\mu\text{g}$ copper (Cu).
- 3.11 Thymol blue indicator solution: dissolve 0.1g thymol blue in 2.15ml of 0.1N sodium hydroxide and dilute to 100ml with water.

4. Apparatus

Spectrophotometer with 10mm cells.

5. Preparation of the test sample

Grind the sample to pass through a stainless steel sieve having apertures about 1mm square.

6. Procedure

6.1 Dissolution of sample

Weigh, to the nearest 0.001g, approximately 10g of the sample prepared in accordance with 5., into a silica dish or basin and place a silica cover on top. Transfer to a cool muffle furnace. Raise the temperature to $450 \pm 10^\circ \text{C}$ and allow to ash until all the carbonaceous matter has disappeared; a slow current of air through the furnace during the initial stages of ashing is desirable. In the case of high-fat content materials, care must be taken to avoid ignition of the sample. When all the organic matter has been destroyed, cool, add 10ml 50% (V/V) hydrochloric acid solution (3.6) and evaporate to dryness on a water-bath. Extract the soluble salts from the residue with two successive 10ml

portions of boiling 2N hydrochloric acid solution (3.7) decanting the solution each time through the same suitable filter paper⁽¹⁾ into a 50ml graduated flask. Then add 5ml of 50% (V/V) hydrochloric acid solution (3.6) and about 5ml of 30% (V/V) nitric acid solution (3.8) to the residue in the basin, and evaporate the mixture to dryness on a hot-plate at low heat. Finally, add a further 10ml of boiling 2N hydrochloric acid solution (3.7) to the residue and filter the solution through the same filter paper into the flask. Wash the basin and the filter with water, and collect the washings in the flask, make up to the mark with water and mix.

6.2 *Determination*

Transfer to a separating funnel a suitable aliquot of the solution prepared in accordance with 6.1, (or a dilution of this solution in N hydrochloric acid), containing not more than 50µg of copper. Add 10ml EDTA-citrate solution (3.3), two drops of thymol blue indicator solution (3.11) and ammonium hydroxide solution (3.4) until the mixture is coloured green or bluish-green. Cool the mixture, add 1ml of sodium diethyldithiocarbamate solution (3.2) and, from a burette, 15ml of carbon tetrachloride (3.1). Stopper the funnel, shake vigorously for two minutes and allow the layers to separate.

Place a piece of cotton-wool in the stem of the funnel and run off the carbon tetrachloride layer into a dry 10mm spectrophotometer cell (4.). Avoid undue exposure of the solution to light.

Measure immediately the absorbance of the sample solution at a wavelength of 436nm, against carbon tetrachloride as reference. Determine the quantity of copper by reference to the calibration curve (6.4).

6.3 *Blank Test*

Carry out a blank test omitting only the sample and following the procedure described in 6.2.

6.4 *Calibration curve*

To a series of separating funnels, transfer 10ml EDTA-citrate solution (3.3) and the following amounts of copper standard working solution (3.10) and 2N sulphuric acid (3.5):

Copper solution	0	1	2.5	5	10	15	20	25 ml
2N H ₂ SO ₄	25	24	22.5	20	15	10	5	0 ml

Proceed as for the test solution, as described in 6.2 commencing "... two drops thymol blue indicator (3.11) ...". Measure the absorbances of the solutions and plot the calibration curve using absorbances as the ordinates and the corresponding quantities of copper in µg as the abscissae.

7. *Expression of the Results*

The copper content in mg/kg of sample is given by the formula:

$$\frac{A \times 50 \times F}{V \times W}$$

where:

A = weight of copper in aliquot taken for colour development as read from the calibration curve after allowing for blank reading (µg);

V = volume of aliquot taken for colour development (ml);

W = weight of test portion in g; and

F = dilution factor (from 6.2).

⁽¹⁾ Whatman No. 541 or equivalent.

17. IRON, COPPER, MANGANESE AND ZINC

1. Scope and Field of Application

This method is for the determination of the trace elements iron, copper, manganese and zinc in feeding stuffs. The lower limits of determination are:—

- iron (Fe): 20mg/kg
- copper (Cu): 10mg/kg
- manganese (Mn): 20mg/kg
- zinc (Zn): 20mg/kg.

2. Principle

The sample is ashed and dissolved in hydrochloric acid, or if it contains no organic substances it is dissolved directly in hydrochloric acid. The elements iron, copper, manganese and zinc are determined by atomic absorption spectrophotometry.

3. Reagents

- 3.1 Hydrochloric acid ($d=1.18\text{g/ml}$).
- 3.2 Hydrochloric acid solution, 6N.
- 3.3 Hydrochloric acid solution, 0.5N.
- 3.4 Hydrofluoric acid, 38 to 40% (V/V) having an iron content of less than 1mg Fe/1,000ml and a residue after evaporation of less than 10mg/1,000ml (as sulphate).
- 3.5 Sulphuric acid ($d=1.84\text{g/ml}$).
- 3.6 Hydrogen peroxide, 100 volumes, 30% oxygen by weight.
- 3.7.1 Iron solution (stock): weigh to the nearest 0.001g, 1g pure iron, dissolve in 200ml 6N hydrochloric acid solution (3.2), add 16ml hydrogen peroxide (3.6) and dilute to 1,000ml with water.
1ml of this solution \equiv 1,000 μg iron (Fe).
- 3.7.2 Iron solution (dilute): dilute 10.0ml of stock solution (3.7.1) to 100ml with water.
1ml of this solution \equiv 10 μg iron (Fe).
- 3.8.1 Copper solution (stock): weigh to the nearest 0.001g, 1g pure copper, dissolve in 25ml 6N hydrochloric acid solution (3.2), add 5ml hydrogen peroxide (3.6) and make up to 1,000ml with water.
1ml of this solution \equiv 1,000 μg copper (Cu).
- 3.8.2 Copper solution (dilute): dilute 10.0ml of stock solution (3.8.1) to 1,000ml with water.
1ml of this solution \equiv 10 μg copper (Cu).
- 3.9.1 Manganese solution (stock): weigh to the nearest 0.001g, 1g pure manganese, dissolve in 25ml 6N hydrochloric acid solution (3.2) and make up to 1,000ml with water.
1ml of this solution \equiv 1,000 μg manganese (Mn).
- 3.9.2 Manganese solution (dilute): dilute 10.0ml of stock solution (3.9.1) to 1,000ml with water.
1ml of this solution \equiv 10 μg manganese (Mn).
- 3.10.1 Zinc solution (stock): weigh to the nearest 0.001g, 1g pure zinc, dissolve in 25ml 6N hydrochloric acid (3.2) and make up to 1,000ml with water.
1ml of this solution \equiv 1,000 μg zinc (Zn).
- 3.10.2 Zinc solution (dilute): dilute 10.0ml of stock solution (3.10.1) to 1,000ml with water.
1ml of this solution \equiv 10 μg zinc (Zn).

NOTE: commercially prepared standard solutions of iron, copper, manganese and zinc may also be used.

- 3.11 Lanthanum chloride solution: dissolve 12g lanthanum oxide in 150ml water, add 100ml 6N hydrochloric acid (3.2) and dilute to 1,000ml with water.

4. Apparatus

Atomic absorption spectrophotometer fitted with iron, copper, manganese or zinc lamps.

5. Procedure

5.1 *Preparation of the solution for analysis*

5.1.1 *In the presence of organic matter*

Weigh to the nearest 0.001g, between 5 and 10g of the prepared sample into a silica or platinum crucible, and place the crucible in a cold muffle furnace. Close the furnace and gradually raise the temperature to 450–475° C over about 90 minutes. Maintain at this temperature for at least 16 hours and then open the furnace and allow the crucible to cool. Moisten the ash with water and transfer it to a 250ml beaker. Wash the crucible with 5ml hydrochloric acid (3.1) and add the latter slowly and carefully to the beaker (there may be a vigorous reaction due to carbon dioxide formation). If necessary add more hydrochloric acid (3.1), stirring until all effervescence has stopped. Evaporate the solution to dryness, occasionally stirring with a glass rod. Add 15ml 6N hydrochloric acid solution (3.2) and 120ml water. Stir with the glass rod, which should be left in the beaker, and cover with a watch glass. Boil the solution gently until dissolution appears complete and filter through a Whatman 541 (or equivalent) filter paper into a 250ml graduated flask. Wash the beaker and filter with 5ml of hot 6N sulphuric acid solution (3.5) and with boiling water. Cool, and make up to the mark with water. (The hydrochloric acid concentration of the solution should be about 0.5N).

NOTE 1: if the residue in the filter paper still appears black due to the presence of carbon, transfer it back into the crucible, place it in the furnace and ash at 450–475° C for 5 hours.

Dissolve the residue in 2ml hydrochloric acid (3.1), evaporate to dryness and add 5ml 6N hydrochloric acid solution (3.2). Heat, filter the solution into the 250ml graduated flask and make up to the mark with water. (The hydrochloric acid concentration of the solution should be about 0.5N).

NOTE 2: green fodder, (fresh or dried) is liable to contain large amounts of vegetable silica which can retain trace elements. For samples of these feeding stuffs, the following procedure must be used.

Carry out the procedure described in 5.1.1 as far as the filtration stage. Wash the filter paper containing the insoluble residue with boiling water and then place it in a platinum crucible. Ignite in the muffle furnace, at a temperature of 550° C until all carbonaceous material has disappeared. Allow to cool, moisten with water, add 10 to 15ml hydrofluoric acid (3.4) and evaporate to dryness on a hot plate. If any silica remains in the crucible, treat with a further 5ml hydrofluoric acid and again evaporate to dryness. Add 5 drops of sulphuric acid (3.5) and heat until no more white fumes are produced. Add 5ml 6N hydrochloric acid solution (3.2), about 30ml water, heat, filter the solution into the 250ml graduated flask, and make up to the mark with water. (The hydrochloric acid concentration of the solution should be about 0.5N).

5.1.2 *In the absence of organic matter (mineral feeding stuffs)*

Weigh to the nearest 0.001g, 5g of the prepared sample into a 250ml beaker, add 5 ml hydrochloric acid (3.1) (take suitable precautions if there is a vigorous reaction due to carbon dioxide formation). Continue as in 5.1.1 from "If necessary add more hydrochloric acid (3.1) . . .".

5.2 *Blank test*

Carry out a blank determination repeating the procedure but omitting the sample.

5.3 Determination

5.3.1 Preparation of the sample and blank test solutions

For the determination of copper, dilute, if necessary, the sample solutions prepared in 5.1.1 or 5.1.2 and the blank solution (5.2) with 0.5N hydrochloric acid solution (3.3) to a concentration within the working range of the spectrophotometer (4.).

For the determination of iron, manganese and zinc, dilute the sample solutions prepared in 5.1.1 or 5.1.2 and the blank test solution (5.2) with 0.5N hydrochloric acid solution (3.3) to a concentration within the working range of the spectrophotometer (4.). Each final solution must contain 10% (V/V) of the lanthanum chloride solution (3.11).

5.3.2 Preparation of the calibration solutions

By diluting the standard solutions 3.7.2, 3.8.2, 3.9.2 and 3.10.2 with 0.5N hydrochloric acid solution (3.3) prepare at least 5 standard solutions of increasing concentrations corresponding to the optimal measuring range of the spectrophotometer for each trace metal. In the case of iron, manganese and zinc the final solutions must contain 10% (V/V) lanthanum chloride solution (3.11).

5.4 Measurement

Set up the spectrophotometer for the determination of the following trace elements, in each case using an oxidising air-acetylene flame.

Iron	248.3nm
Copper	324.8nm
Manganese	279.5nm
Zinc	213.8nm

Spray successively, in triplicate, the standard solutions (5.3.2), the sample solutions and the blank test solutions (5.3.1), washing the instrument through with distilled water between each spraying. Plot the calibration curve, using the mean absorbances as the ordinates and the corresponding concentrations of trace elements in $\mu\text{g/ml}$ as the abscissae. Determine the concentration of the trace element (Cu, Fe, Mn or Zn) in the final sample and blank solutions by reference to the calibration curves.

6. Expression of the Results

Calculate the trace element (Fe, Cu, Mn or Zn) content of the sample taking into account the weight of the test sample and the dilutions carried out in the course of the analysis. Express the result either as a percentage or as mg/kg.

18a. MAGNESIUM—GRAVIMÉTRIC METHOD

1. Scope and Field of Application

This method is for the determination of magnesium in feeding stuffs. It is particularly appropriate for contents of magnesium of 1% and above, but it should not be used when substantial quantities of mineral phosphates are present.

2. Principle

The sample is ashed and taken up in acid solution. Calcium is separated by the addition of ammonium oxalate, and the magnesium precipitated with ammonium phosphate. The magnesium ammonium phosphate is ignited to magnesium pyrophosphate and weighed.

3. Reagents

- 3.1 Citric acid solution: 30g citric acid monohydrate per 100ml.
- 3.2 Ammonia ($d=0.88\text{g/ml}$).
- 3.3 Ammonia solution: dilute 5ml ammonia (3.2) with water to 100ml.

- 3.4 Ammonium oxalate solution: saturated aqueous solution.
- 3.5 Ammonium phosphate solution: 20g diammonium hydrogen phosphate per 100ml.
- 3.6 Calcium wash solution: dissolve 1g oxalic acid [(COOH)₂.2H₂O] and 2g ammonium oxalate in water and dilute to 100ml.
- 3.7 Hydrochloric acid, (d=1.18g/ml).
- 3.8 Hydrochloric acid 50% (V/V): dilute an appropriate volume of hydrochloric acid (3.7) with an equal volume of water.
- 3.9 Hydrochloric acid 20% (V/V): dilute 20ml hydrochloric acid (3.7) with water to 100ml.
- 3.10 Methyl red indicator solution: dissolve 0.025g methyl red in 5ml 95% (V/V) ethanol with the aid of 0.5ml 0.1N sodium hydroxide solution. Dilute to 250ml with 50% (V/V) ethanol.

4. Apparatus

- 4.1 Platinum, silica or porcelain crucible, suitable for ashing.
- 4.2 Electric muffle furnace, capable of being maintained at a temperature up to 950° C.
- 4.3 Filter crucible of 5 to 15 microns porosity, suitable for ignition at temperatures up to 1,000° C.

5. Procedure

5.1 Dissolution of sample

Weigh to the nearest 0.001g, a quantity of the prepared sample expected to contain between 0.05g and 0.50g of magnesium and incinerate at a temperature not exceeding 550° C until all the organic matter has been destroyed. Allow to cool, moisten the ash with water and cautiously add 10ml of 50% (V/V) hydrochloric acid (3.8), avoiding loss by use of a cover glass. Wash the cover glass with water, add the washings to the basin and evaporate to dryness. Continue the heating for at least one hour in order to dehydrate any silica that might be present. Cool, add 10ml of 20% (V/V) hydrochloric acid (3.9), heat on a steam bath and then filter into a 50ml graduated flask. Repeat the extraction with two further 10ml portions of 20% (V/V) hydrochloric acid (3.9). Wash the basin and filter with hot water and collect the washings in the flask. Cool, make up to the mark and mix.

5.2 Precipitation and determination

Transfer a measured volume (v) of the solution prepared in accordance with 5.1, containing between 0.04 and 0.06g of magnesium, to a 500ml beaker and dilute with water to 100ml. Add ammonia solution (3.3) until a slight precipitate is formed then add citric acid solution (3.1) until the precipitate just dissolves and add 3-4ml in excess. Heat the solution to boiling and add 0.2ml (4 or 5 drops) of methyl red indicator solution (3.10). Add 25ml of hot ammonium oxalate solution (3.4) gradually with constant stirring then add dilute ammonia solution (3.3) drop by drop until the solution is neutral or faintly alkaline (colour changes from red to yellow). Heat the mixture on a steam bath for one hour. Decant the clear supernatant liquid through a suitable filter paper⁽¹⁾, transfer the precipitate quantitatively to the filter using the calcium wash solution (3.6), rinse the beaker with the same solution, pass the rinsings through the precipitate and collect them in the filtrate. Test the filtrate for absence of calcium by adding a few drops of ammonium oxalate solution (3.4). Reserve the filtrate.

Dissolve the precipitate by passing 10ml of 20% (V/V) hydrochloric acid (3.9) through the filter and collect the extract in a 250ml beaker. Repeat with two further quantities of 20% (V/V) hydrochloric acid (3.9) and finally wash the filter with water. Add 2 or 3 drops of methyl red indicator (3.10) to the combined extracts, heat to boiling and add 25ml of ammonium oxalate solu-

⁽¹⁾ Whatman No. 40 or equivalent.

tion (3.4). Neutralise the solution by adding dilute ammonia (3.3) with constant stirring until the colour changes from red to yellow. Heat on a steam bath for one hour and then filter through a suitable filter paper⁽¹⁾, finally transferring the precipitate with the aid of calcium wash solution (3.6). Retain the filtrate and add it to the filtrate reserved from the first precipitation. Measure the approximate volume of the combined filtrates and add 20% (V/V) hydrochloric acid (3.9) until just acid to methyl red. Add, while stirring with a glass rod, 20ml of ammonium phosphate solution (3.5) taking care not to touch the sides of the beaker with the rod. Continue to stir and add ammonia (3.2) drop by drop until the mixture is neutralised, then add a further 10ml of ammonia (3.2) for each 100ml in the beaker. Allow the beaker to stand for at least 4 hours, or preferably, overnight.

Transfer the precipitate to a tared crucible (4.3) and wash the residue with cold ammonia solution (3.3), ensuring that any precipitate adhering to the beaker and glass rod is transferred to the crucible. Discard the filtrate and washings. Dry the crucible and precipitate at 120° C, transfer to a muffle furnace and ensure that a temperature of at least 950° C is maintained for one hour. Allow the crucible to cool in a desiccator and weigh. Repeat the heating and cooling until constant weight is achieved.

6. Expression of the Results

Calculate the percentage of magnesium in the sample using the formula:

$$\text{Magnesium (\%)} = \frac{m \times 21.85 \times 50}{w \quad v}$$

where:

m = weight of the precipitate (g);

w = weight of sample taken (g); and

v = measured volume (ml) taken for determination (5.2).

18b. MAGNESIUM—ATOMIC ABSORPTION METHOD

1. Scope and Field of Application

This method is for the determination of magnesium in feeding stuffs. It is particularly appropriate for determining magnesium contents lower than 5%.

2. Principle

The sample is ashed and dissolved in dilute hydrochloric acid, or if it contains no organic substances, it is dissolved directly in dilute hydrochloric acid. The solution is diluted and the magnesium content determined by atomic absorption spectrophotometry at 285.2nm.

3. Reagents

3.1 Hydrochloric acid (d=1.18g/ml).

3.2 Magnesium ribbon or wire, or magnesium sulphate heptahydrate.

3.3 Releasing agent.

3.3.1 Lanthanum oxide solution: moisten 117.3g lanthanum oxide (La₂O₃), low in magnesium content, with water, slowly add 350ml hydrochloric acid (3.1) and stir until the lanthanum oxide is dissolved. Allow to cool and dilute to 1,000ml with water.

3.3.2 Strontium salt solution (chloride or nitrate) containing 25g per 1,000ml of strontium (use 76.08g SrCl₂·6H₂O or 60.38g Sr(NO₃)₂ per 1,000ml).

⁽¹⁾ Whatman No. 40 or equivalent.

- 3.4 Magnesium standard solution: weigh to the nearest 0.001g, exactly 1.0g of magnesium (3.2) from which the oxide coating has been carefully removed, or the corresponding quantity (10.143g) of magnesium sulphate heptahydrate (3.2) and transfer to a 1,000ml graduated flask. Dissolve the metal or magnesium sulphate in 80ml of hydrochloric acid (3.1) and dilute to the mark with water. 1ml of this solution \equiv 1,000mg of magnesium (Mg).

4. Apparatus

- 4.1 Electric muffle furnace capable of being maintained at 550° C.
4.2 Atomic absorption spectrophotometer, with magnesium hollow cathode lamp.

5. Procedure

5.1 *Dissolution of sample*

5.1.1 *Feeding stuffs composed exclusively of mineral substances*

Weigh to the nearest 0.001g, approximately 5g of the prepared sample and transfer to a 500ml graduated flask with 250 to 300ml water. Add 40ml hydrochloric acid (3.1), bring to the boil and keep the liquid gently boiling for 30 minutes. Allow to cool, make up to volume with water, mix and filter into a dry beaker through a dry pleated filter. Discard the first 30ml of the filtrate. In the presence of silica, treat the sample with a sufficient quantity (15-30ml) of hydrochloric acid (3.1), evaporate to dryness on a steam bath and transfer to an oven at 105° C for one hour. Proceed as from the third sentence of 5.1.2.

5.1.2 *Feeding stuffs composed predominantly of mineral substances*

Weigh to the nearest 0.001g, approximately 5g of the prepared sample into a crucible and ash at 550° C in the muffle furnace (4.1) until an ash which is free from carbonaceous particles is obtained and leave to cool. In order to eliminate silica, add to the ash a sufficient quantity (15-30ml) of hydrochloric acid (3.1) evaporate to dryness on a steam bath and transfer to an oven at 105° C for one hour. Treat the residue with 10ml hydrochloric acid (3.1) and transfer to a 500ml graduated flask using warm water. Leave to cool and make up to volume with water. Mix and filter into a dry beaker through a dry pleated filter. Discard the first 30ml of the filtrate.

5.1.3 *Feeding stuffs composed predominantly of organic substances*

Weigh to the nearest 0.001g, approximately 5g of the prepared sample into a crucible and ash at 550° C in the muffle furnace (4.1) until an ash which is free from carbonaceous particles is obtained. Treat the ash with 5ml hydrochloric acid (3.1), evaporate to dryness on a steam bath and then dry for one hour in an oven at 105° C in order to render any silica insoluble. Treat the ash with 5ml hydrochloric acid (3.1) transfer to a 250ml graduated flask using warm water, bring to the boil, leave to cool and make up to volume with water. Mix and filter into a dry beaker through a dry pleated filter. Discard the first 30ml of the filtrate.

5.2 *Determination*

Transfer a suitable volume of the solution obtained in accordance with 5.1 to a 100ml graduated flask, add 10ml of the releasing agent solution (3.3.1) or (3.3.2), make up to the mark with water and mix. The magnesium content of this solution must be within the optimal measuring range of the spectrophotometer and the hydrochloric acid concentration must not exceed 0.4N. Measure the absorption of the solution at 285.2nm.

5.3 *Calibration curve*

Prepare at least five standard solutions of increasing concentration of magnesium, corresponding to the optimal measuring range of the spectrophotometer (4.2), by diluting suitable volumes of the magnesium standard solution (3.4). Measure the absorption of these solutions at a wavelength of 285.2nm. Construct a graph relating absorbances to the amounts of magnesium present.

6. Expression of the Results

Calculate the quantity of magnesium in the sample by relation to the calibration curve (5.3). Express the result as a percentage of the sample.

19. VITAMIN A (RETINOL)

1. Scope and Field of Application

This method is for the determination of Vitamin A in feeding stuffs. The lower limit of the determination is 10,000 IU/kg for highly pigmented feeds and 4,000 IU/kg for others⁽¹⁾. Products are classified in two groups, according to their presumed retinol content:

Group A: contents lower than 200,000 IU/kg;

Group B: contents equal to or greater than 200,000 IU/kg.

2. Principle

The sample is hydrolysed in hot ethanolic potassium hydroxide solution, either in the presence of an antioxidant or in a nitrogen atmosphere. The mixture is extracted with 1,2-dichloroethane. The extract is evaporated to dryness and treated with light petroleum. The solution is chromatographed on a column of aluminium oxide (for Group B products, chromatography is only required in certain cases). For Group A products, the retinol is determined by development of a coloured complex according to the Carr-Price reaction and measurement of its absorbance at 610nm. For Group B products, the determination is by measurement of the absorbance at 325nm.

3. Reagents

a. used for analysing products of Groups A and B

- 3.1 Aluminium oxide, neutral: ignite for 8 hours at 750° C, cool in a desiccator and keep in a brown glass bottle fitted with a ground-glass stopper. Before use in chromatography moisten as follows: place in a brown glass bottle 10g aluminium oxide and 0.9ml water, seal with a stopper, reheat for 5 minutes in a boiling water bath while shaking. Allow to cool. Verify the activity of the aluminium oxide thus prepared by subjecting a known quantity of retinol (3.17) (ca. 500 IU) to the procedure of 5.3 and 5.4 and checking recovery.
- 3.2 Aluminium oxide, basic, degree of activity 1⁽²⁾.
- 3.3 1,2-Dichloroethane.
- 3.4 Diethyl ether: remove peroxides and traces of water by chromatography on a column of basic aluminium oxide (3.2) (25g aluminium oxide per 250ml diethyl ether).
- 3.5 Ethanol, 96% (V/V).
- 3.6 Nitrogen.
- 3.7 Light petroleum, boiling range 40-60° C. If necessary, purify as follows: stir 1,000ml light petroleum with 20ml lots of concentrated sulphuric acid until the acid remains colourless. Remove the acid and wash the light petroleum successively with 500ml water, twice with 250ml of sodium hydroxide solution (approximately 2.5N) and three times with 500ml water. Remove the aqueous layer, dry the light petroleum for 1 hour over active carbon and anhydrous sodium sulphate, filter and distil.
- 3.8 Diethyl ether solutions: prepare a series of solutions containing 4, 8, 12, 16 and 20% (V/V) diethyl ether (3.4) in light petroleum.
- 3.9 Potassium hydroxide solution: dissolve 500g potassium hydroxide in water and dilute to 1,000ml.
- 3.10 Sodium ascorbate solution: 10g sodium ascorbate per 100ml.

⁽¹⁾ 1 IU=0.3µg of retinol.

⁽²⁾ Woelm, Merck or equivalent.

- 3.11 Sodium sulphide solution, 0.5 molar in 70% (V/V) glycerine.
- 3.12 Potassium hydroxide solution, N.
- 3.13 Potassium hydroxide solution, 0.5N.

b. used exclusively for analysing Group A products.

- 3.14 Benzene; crystallisable.
- 3.15 Chloroform: remove the ethanol, phosgene and traces of water by chromatography on a column of basic aluminium oxide (3.2). (50g aluminium oxide per 200ml chloroform; it is advisable to chromatograph the first 50ml of the eluate a second time).
- 3.16 Carr-Price reagent: stir approximately 25g antimony trichloride (kept in a desiccator) with 100ml chloroform (3.15) until the solution is saturated. (If necessary warm to 50° C and allow to cool). A slight deposit of antimony trichloride causes no problem. Add 2ml acetic anhydride. Keep in a refrigerator in a moisture-proof brown glass bottle with ground-glass stopper. The solution keeps for 2 to 3 weeks.
- 3.17 Retinol—standardised spectrophotometrically.

c. used exclusively for analysing Group B products.

- 3.18 Propan-2-ol.

4. Apparatus

- 4.1 Rotary vacuum evaporator.
- 4.2 Glass chromatography tubes (length: 300mm; internal diameter: about 13 mm).
- 4.3 Spectrophotometer with 10mm cells. Measurements in the UV require silica cells.
- 4.4 UV lamp 365nm.

5. Procedure

N.B.—All operations must be carried out away from direct sunlight using amber glass where necessary.

5.1 Test portion

From the prepared sample, take a quantity proportional to the presumed retinol content, thus:

- 0.1-1.0g for contents greater than 20,000,000 IU/kg;
- 3.0-5.0g for contents between 400,000 and 20,000,000 IU/kg;
- 10-20g for contents between 200,000 and 400,000 IU/kg; and
- 30g for Group A products.

Immediately place the test sample in a 500ml flask with a ground-glass stopper.

5.2 Hydrolysis and extraction⁽¹⁾

Add successively to the sample 40ml ethanol (3.5), 2ml sodium ascorbate solution (3.10)⁽²⁾, 10ml potassium hydroxide solution (3.9) and 2ml sodium sulphide solution (3.11).

Heat for 30 minutes at 70-80° C under a reflux condenser and then cool under a stream of water. Add 50ml ethanol (3.5) and 100ml 1,2-dichloroethane (3.3). Shake vigorously and then carefully decant the supernatant liquid into a separating funnel avoiding transfer of solids. Add 150ml potassium hydroxide solution (3.12) shake for 30 seconds and allow to stand

(1) For milk feeds and products with a tendency to agglomerate or swell, double the quantity of the reagents shown in the first and second paragraphs of 5.2.

(2) Sodium ascorbate need not be added when hydrolysis is carried out in a nitrogen atmosphere.

until the layers have separated. Collect the lower dichloroethane layer in a separating funnel, add 40ml potassium hydroxide solution (3.13), shake for 10 seconds and allow to stand until the layers have separated. Collect the dichloroethane layer in a separating funnel, and wash at least 6 times with 40ml lots of water. It is essential that the dichloroethane is free of alkali and washing must be continued until the wash water gives no positive reaction to phenolphthalein. Collect the dichloroethane layer and remove the last traces of water using strips of filter paper.

Evaporate to dryness an aliquot part of the solution under vacuum on a water bath at 40° C. Rapidly treat the residue with 5ml light petroleum (3.7).

For Group A products, chromatograph as shown in 5.3.1.

For Group B products, transfer the solution to a 50ml graduated flask, make up to volume with light petroleum (3.7), mix and measure the absorbance as shown in 5.4.3.

5.3 Chromatography

5.3.1 Group A products

Fill a chromatograph tube (4.2) to a height of 200mm with aluminium oxide (3.1) previously slurred with light petroleum (3.7). Place in the tube the solution obtained in 5.2 and immediately add 20ml light petroleum (3.7). Elute successively with 10ml lots of the light petroleum solutions at 4, 8, 12, 16 and 20% diethyl ether (3.8) under pressure or partial vacuum, the rate of flow being 2 to 3 drops per second.

The carotene is eluted first⁽¹⁾. The retinol is generally eluted with the light petroleum solution at 20% diethyl ether (3.8). The elution is followed under UV light (brief irradiation of the column with the mercury lamp). The fluorescent zone of the retinol is clearly separated from the yellow xanthophyll zones following it. If the zones have not separated the chromatography should be repeated, using increased concentrations of diethyl ether in the eluting solvent. Collect the eluate fraction containing the retinol in an Erlenmeyer flask.

5.3.2 Group B products

Chromatography must only be carried out if the absorbance measurements obtained in 5.4.3 do not conform to the requirements given in 5.4.3.

If chromatography proves necessary, place in the chromatography column an aliquot part of the solution in the light petroleum obtained in accordance with 5.2, containing approximately 500 IU of retinol, and chromatograph as shown in 5.3.1.

5.4 Determination

5.4.1 Group A products

Evaporate to dryness under vacuum the eluate containing the retinol obtained in accordance with 5.3.1. Treat the residue with 2ml benzene (3.14) using a safety pipette. Take 0.3ml of this solution and add 3ml of the Carr-Price reagent (3.16). A blue colour develops. Measure the absorbance at a wavelength of 610nm exactly 30 seconds after the reaction has begun against a reference solution prepared from 0.3ml of benzene and 3ml of Carr-Price reagent. Determine the retinol content by reference to the calibration curve (5.4.2).

5.4.2 Calibration curve

Prepare in benzene (3.14) a series of solutions of retinol (3.17) containing 2 to 16 IU per 0.3ml. Treat this volume (0.3ml) of each solution with 3ml Carr-Price reagent (3.16) and measure the absorbance at a wavelength of 610nm.

(¹) Carotene content may be determined by absorbance measurement at 450nm.

$$E_{10\text{mm}}^{1\%} = 2,600$$

5.4.3 Group B products

Take an aliquot part of the solution in light petroleum obtained in accordance with 5.2 containing approximately 200 IU retinol. Evaporate to dryness under vacuum and dissolve the residue in 25ml propan-2-ol (3.18). Measure the absorbance in the spectrophotometer at wavelengths of 325, 310 and 334nm. The absorption maximum is located at a wavelength of 325nm. The retinol content of the solution is calculated as follows:

Absorbance at 325nm \times 18.30 = IU of retinol/ml

However, the ratios of the absorbances $\frac{X}{Y}$ and $\frac{Z}{Y}$ must be 0.857 where:

X = absorbance at 310nm;

Y = absorbance at 325nm; and

Z = absorbance at 334nm.

If one of these ratios differs appreciably from this value (<0.830 or >0.880), the measurement of the absorbances must be preceded by chromatography in accordance with the method given in 5.3.2. If the measurement of the absorbances carried out after chromatography shows that the above-mentioned ratios still differ appreciably from the value of 0.857 (<0.830 or >0.880), the determination must be carried out in accordance with the method given for Group A products.

6. Expression of the Results

Calculate the retinol content of the sample taking into account the weight of the test sample and the dilutions carried out in the course of analysis. Express the results in IU of retinol per kg of feeding stuffs.

20. THIAMINE HYDROCHLORIDE (VITAMIN B₁, ANEURINE)

1. Scope and Field of Application

This method is for the determination of thiamine hydrochloride (aneurine, Vitamin B₁) in feeding stuffs. The lower limit of the determination is 5mg/kg.

2. Principle

The sample is treated with hot dilute sulphuric acid, hydrolysed enzymatically and then subjected to alkaline oxidation. The thiochrome formed is extracted with 2-methylpropan-1-ol, and determined spectrofluorimetrically.

3. Reagents

- 3.1 Ethanol, 96% (V/V).
- 3.2 2-Methylpropan-1-ol.
- 3.3 Multienzymatic preparation containing protease, phosphatase and amylase⁽¹⁾.
- 3.4 Sodium metabisulphite (Na₂S₂O₅).
- 3.5 Potassium ferricyanide solution: 20g potassium ferricyanide per 100ml.
- 3.6 Potassium hydroxide solution: 25g potassium hydroxide per 100ml.
- 3.7 Oxidising mixture: mix 2ml of potassium ferricyanide solution (3.5) with 48ml of potassium hydroxide solution (3.6). The mixture does not keep for more than 4 hours.
- 3.8 Sodium acetate solution, 2.5N.
- 3.9 Sulphuric acid solution, 0.2N.

⁽¹⁾ e.g. Clarase.

- 3.10 Thiamine standard solution: dissolve 127.1mg thiamine hydrochloride ($C_{12}H_{17}ClN_4OS \cdot HCl$), previously dried under vacuum to constant weight, in 1,000ml of dilute sulphuric acid (3.9). 1ml of this solution contains $100\mu g$ of thiamine base ($C_{12}H_{17}ClN_4OS$). It will keep for one month if stored in a cool dark place.

4. Apparatus

- 4.1 Centrifuge;
4.2 Spectrofluorimeter with 10mm silica cells.

5. Procedure

5.1 Enzymatic hydrolysis

Place in each of two 250ml graduated flasks, A and B, identical amounts of the prepared sample containing approximately $100\mu g$ thiamine base and 125ml sulphuric acid (3.9). Also add to flask A only, 1ml standard solution (3.10) (internal standard).

Shake the flasks vigorously, place on a steam bath and keep there for 15 minutes, shaking occasionally. Allow to cool to approximately $45^\circ C$. Add to each flask 20ml sodium acetate solution (3.8) and 0.5g multienzymatic preparation (3.3), then allow to stand for 20 minutes. Cool to room temperature if necessary and then add 20ml sodium acetate solution (3.8), make up to volume with water, mix and filter. Collect filtrates A and B after having discarded the first 15ml. Prepare the following solutions:

5.1.1 Reference solution T

Place in a centrifuge tube 5ml filtrate A and approximately 10mg sodium metabisulphite (3.4). Immerse the tube in a boiling water bath for 15 minutes and then allow to cool to room temperature.

5.1.2 Solutions A (internal standard) and B (sample)

Place 5ml filtrate A in a centrifuge tube and 5ml filtrate B in another centrifuge tube.

5.2 Oxidation

Add to solutions T, A and B, 5ml of the oxidising mixture (3.7) and, one minute later, 10ml 2-methylpropan-1-ol (3.2). Stopper the tubes and shake vigorously for 5 seconds. Allow to stand for one minute and centrifuge (4.1) so as to separate the layers. From each tube transfer 5ml of the supernatant 2-methylpropan-1-ol (3.2) layer to separate 25ml graduated flasks, make up to volume with ethanol (3.1) and mix; label these extracts T, A and B.

5.3 Measurement of fluorescence

Carry out the measurements at the wavelength for which the spectrofluorimeter (4.2) gives an optimal response to the fluorescence of the thiochrome. Irradiate at a wavelength of approximately 365nm. Adjust the instrument to zero using extract T. Measure the intensity of fluorescence of extracts A and B.

6. Expression of the Results

The thiamine hydrochloride content in mg/kg of the sample is calculated from the formula:

$$\frac{b \times d}{c \times (a - b)}$$

where:

a=intensity of fluorescence of extract A (internal standard);

b=intensity of fluorescence of extract B (sample);

c=weight of the test sample in grams; and

d=amount of thiamine hydrochloride in μg added to the test sample (internal standard).

21. ASCORBIC ACID AND DEHYDROASCORBIC ACID (VITAMIN C)

1. Scope and Field of Application

This method is for the determination of the total quantity of ascorbic and dehydroascorbic acids (Vitamin C) in feeding stuffs. The lower limit of the determination is 20mg/kg. Products are classified in two groups, according to their presumed Vitamin C content:

Group A: contents lower than 10g/kg;

Group B: contents equal to or greater than 10g/kg.

2. Principle

The sample is suspended in a dilute solution of metaphosphoric acid and extracted with chloroform. The aqueous phase is treated with a solution of 2,6-dichlorophenolindophenol in order to transform the ascorbic acid into dehydroascorbic acid, and then with a solution of 2,4-dinitrophenylhydrazine. The hydrazone formed is extracted with a mixture of ethyl acetate, glacial acetic acid and acetone. The solution is chromatographed on a column of silica gel, the eluate evaporated to dryness and the residue dissolved in dilute sulphuric acid. The absorbance of the solution is measured at 509nm.

For Group A products the eluate resulting from chromatography on the column is further subjected to thin layer chromatography to isolate the hydrazone.

3. Reagents

- 3.1 Carbon dioxide (gas).
- 3.2 Chloroform.
- 3.3 Filtration aid.
- 3.4 Nitrogen.
- 3.5 Silica gel, particle size 0.05 to 0.2mm.
- 3.6 Silica gel, Stahl grade H, for thin layer chromatography.
- 3.7 Mixture of ethyl acetate (96 parts by volume), glacial acetic acid (2 parts by volume) and acetone (2 parts by volume).
- 3.8 Mixture of dichloromethane (97 parts by volume) and glacial acetic acid (3 parts by volume).
- 3.9 2,4-Dinitrophenylhydrazine: dissolve 2g 2,4-dinitrophenylhydrazine in 100ml dilute sulphuric acid (25ml sulphuric acid ($d=1.84\text{g/ml}$) diluted by making up to 100ml with water). Stored at a cool temperature, this solution keeps for one week.
- 3.10 Eluting solvent for thin layer chromatography: mix 75ml diethyl ether, 25ml ethyl acetate and 4ml acetic acid (96g per 100ml). Renew after two to three chromatographic runs.
- 3.11 Metaphosphoric acid solution: dissolve 200g of ground metaphosphoric acid in water and make up to 2,000ml with water. Keep at 4° C. This solution is stable for one week.
- 3.12 Sulphuric acid, dilute solution: place 105ml water in a 200ml graduated flask, and cautiously make up to volume with sulphuric acid ($d=1.84\text{g/ml}$).
- 3.13 2,6-Dichlorophenolindophenol solution: 0.5g per 100ml. Prepare immediately before use.
- 3.14 L-ascorbic acid solution: dissolve 50mg L-ascorbic acid in approximately 20ml metaphosphoric acid solution (3.11) and make up to 100ml with water. Prepare immediately before use.

4. Apparatus

- 4.1 Water bath controlled at 20° C.
- 4.2 Centrifuge.
- 4.3 Rotary vacuum evaporator.
- 4.4 Glass chromatography tubes (length: 100mm; internal diameter: 20mm), with a sintered disc (e.g. Allihn tubes).
- 4.5 Spectrophotometer with 10mm cells.
- 4.6 Apparatus for thin layer chromatography, with silica gel plates (3.6) coated to a depth of 0.5 to 0.6mm. (Ready-made plates are suitable). Dry the plates for 2½ to 3 hours in a drying oven at 120 to 130° C. Allow to cool and then keep in a desiccator for at least 24 hours before use.

5. Procedure

5.1 Extraction

Place in each of two 250ml graduated flasks A and B, identical quantities (up to 10g, according to the presumed ascorbic acid content, weighed to the nearest 0.001g) of the prepared sample. Add to flask B (at 4° C) 30ml chloroform (3.2) and 25ml metaphosphoric acid solution (3.11). Add to flask A, 30ml chloroform (3.2) and an aliquot portion of the standard solution (3.14) corresponding to the amount of ascorbic acid presumed to be present in the sample; make up the volume of the aqueous phase to 25ml with metaphosphoric acid solution (3.11). Stopper the flasks, shake briefly, and then allow to stand for 10 to 15 minutes.

To each flask add 25ml water, stopper and shake vigorously for 10 seconds and allow to stand for 10 to 15 minutes in the water bath (4.1). Centrifuge to separate the aqueous and chloroform layers. The aqueous phases are retained for subsequent analysis.

5.2 Oxidation

Place in a 50ml stoppered flask, a volume of extract B, expected to contain about 160µg ascorbic acid (if necessary, dilute the extract with a mixture of equal volumes of metaphosphoric acid solution (3.11) and water, such that this weight of ascorbic acid is contained in about 10ml). Place in a second 50ml flask an identical volume of extract A. Dilute the contents of each flask to 40ml with a mixture of equal volumes of metaphosphoric acid solution (3.11) and water. Add between 0.5 and 1ml of dichlorophenolindophenol solution (3.13) and mix well. A red colour develops which should persist for at least 15 minutes. Add approximately 300mg filtration aid (3.3), shake and filter through a dry pleated filter. The filtrate need not necessarily be clear.

5.3 Reaction with 2,4-dinitrophenylhydrazine and hydrazone extraction

Pipette 10ml of the filtrate obtained in accordance with 5.2 to a centrifuge tube, add 2ml 2,4-dinitrophenylhydrazine solution (3.9) and mix. Pass a stream of nitrogen (3.4) or carbon dioxide (3.1) rapidly into the tube, stopper the tube and immerse it for approximately 15 hours (overnight) in the water bath (4.1).

Then add 3ml water, 20ml of the ethyl acetate/glacial acetic acid/acetone mixture (3.7) and approximately 800mg filtration aid (3.3). Stopper the tube, shake vigorously for 30 seconds and centrifuge. Place 15ml of the supernatant phase in an evaporation flask and evaporate under reduced pressure in the rotary evaporator (4.3) until an oily residue is obtained. Dissolve the residue in 2ml of the ethyl acetate/glacial acetic acid/acetone mixture (3.7) by heating at 50° C, allow to cool, add 10ml of the dichloromethane/glacial acetic acid mixture (3.8) and mix.

5.4 Chromatography on a column

Fill a chromatography tube (4.4) up to a level of 30mm with the dichloromethane/glacial acetic acid mixture (3.8). Suspend (shaking vigorously) 5g silica gel (3.5) in 30ml of the dichloromethane/glacial acetic acid mixture (3.8); pour the suspension into the tube, allow to stand and then compress under nitrogen (3.4) at low pressure. Decant into the tube the

solution obtained in 5.3, rinse the flask with a small quantity of the dichloromethane/glacial acetic acid mixture (3.8) and decant into the tube, then fill the latter with this solvent (3.8). Wash the column with 5ml portions of this solvent (3.8) until the eluate is colourless; discard this eluate.

Elute the reddish zone at the top of the column with the ethyl acetate/glacial acetic acid/acetone mixture (3.7), collect the eluate and evaporate to dryness.

5.4.1 *For Group A products (contents of vitamin C lower than 10g/kg):* dissolve the residue in 2ml of the ethyl acetate/glacial acetic acid/acetone mixture (3.7) and chromatograph immediately on a thin layer plate as shown in 5.5.

5.4.2 *For Group B products (contents of vitamin C equal to or greater than 10g/kg):* treat the oily residue with 4ml dilute sulphuric acid (3.12), shake vigorously to dissolve the residue completely and measure the absorbance as shown in 5.6.

5.5 *Thin layer chromatography*

Carry out in duplicate the operations described as follows. Place in a thin line on the plate (4.6) 0.5ml of the solution obtained in accordance with 5.4.1. Using the eluting solvent (3.10) develop for at least 20 minutes in a tank saturated with solvent vapour, until the pink-coloured hydrazone zone is clearly separated. Allow to dry in the open. Remove the pink zone quantitatively from the plate and transfer it into a chromatography tube (4.4).

Elute successively once with 2ml and twice with 1.5ml of the ethyl acetate/glacial acetic acid/acetone mixture (3.7). Collect the eluate in a small flask (the last part must be colourless). Evaporate to dryness, treat the oily residue with 4ml dilute sulphuric acid (3.12), shake vigorously to dissolve the residue completely and measure the absorbance.

5.6 *Determination*

Measure the absorbance at a wavelength of 509nm, 20 to 30 minutes after dissolving the residue in sulphuric acid against a reference solution of dilute sulphuric acid (3.12).

5.7 *Blank Test*

Carry out a blank test applying the same procedure but without the sample.

6. Expression of the Results

The vitamin C content of the sample in g per kg is calculated from the formula:

$$\frac{e \times (c - a) \times F}{1,000 \times d \times (b - c)}$$

where:

a=absorbance of the blank;

b=absorbance of the sample plus internal standard solution;

c=absorbance of the sample solution;

d=weight, in grams, of the test sample;

e=weight, in μg , of ascorbic acid added as internal standard; and

F=dilution factor (5.2).

22. MENADIONE (VITAMIN K₃)

1. Scope and Field of Application

This method is for the determination of menadione (Vitamin K₃) in feeding stuffs. The lower limit of the determination is 1mg/kg.

2. Principle

The sample is extracted with diluted ethanol, clarified with tannin solution and centrifuged. The supernatant is treated with a solution of sodium carbonate; the menadione is extracted with 1,2-dichloroethane. The dichloroethane extract is treated, according to its menadione content, either directly or after evaporation, with 2,4-dinitrophenylhydrazine in solution in ethanol acidified with hydrochloric acid. The resulting hydrazone is treated with ammonia in excess to form a blue-green complex, the absorbance of which is measured at 635nm.

3. Reagents

- 3.1 1,2-Dichloroethane.
- 3.2 Ethanol, absolute.
- 3.3 Ethanol, 40% (V/V).
- 3.4 Hydrochloric acid ($d=1.18\text{g/ml}$).
- 3.5 Ammonia solution, 25% (V/V): dilute one volume of ammonia ($d=0.88\text{g/ml}$) with three volumes of water.
- 3.6 Sodium carbonate solution: 10g sodium carbonate (anhydrous) per 100ml.
- 3.7 Tannin solution: 10g purified powdered tannin per 100ml.
- 3.8 Ammonia-ethanol mixture: mix one volume of ethanol (3.2) with one volume of ammonia solution (3.5).
- 3.9 2,4-Dinitrophenylhydrazine reagent: dissolve 0.04g of 2,4-dinitrophenylhydrazine in about 40ml of boiling absolute ethanol (3.2). Allow to cool, transfer to a 50ml graduated flask. Add 0.4ml of hydrochloric acid (3.4) and make up to volume with absolute ethanol. Prepare immediately before use.
- 3.10 Standard solutions of menadione: dissolve 20mg menadione (Vitamin K_3) in 1,2-dichloroethane (3.1) and make up to 200ml. Dilute aliquots of this stock solution with 1,2-dichloroethane (3.1) to obtain a series of solutions with menadione concentrations between 2 and $10\mu\text{g}$ per ml. These solutions must be freshly prepared.

4. Apparatus

- 4.1 Mechanical shaker.
- 4.2 Centrifuge.
- 4.3 Rotary vacuum evaporator.
- 4.4 Spectrophotometer, with 10mm cells.
- 4.5 Phase separating paper ⁽¹⁾.

5. Procedure

- N.B.—1. All operations must be carried out away from direct sunlight, using amber glass where necessary.
2. All glassware must be free from detergent and washed first with 50% hydrochloric acid (V/V) then with acetone and dried.

5.1 Extraction

For vitamin-concentrates and premixes weigh to the nearest 0.001g, between 0.1 and 5g of the prepared sample; for other feeding stuffs weigh to the nearest 0.01g, 20 to 30g of the prepared sample. Transfer to a 250ml conical flask with ground-glass stopper. Add to the test sample exactly 96ml dilute ethanol (3.3) and shake mechanically for 15 minutes at room temperature. Then add 4ml tannin solution (3.7), mix, transfer the extract into a centrifuge tube, centrifuge until a clear solution is obtained and decant. Place 20 to 40ml, accurately measured, of the extract in a 250ml separator, add 50ml 1,2-dichloroethane (3.1), mix and add 20ml sodium carbonate solution (3.6). Shake vigorously for 30 seconds and then collect the dichloroethane phase in a

⁽¹⁾ Whatman No. 1PS or equivalent.

100ml separator. Add 20ml water, shake again for 15 seconds, allow the phases to separate and collect the dichloroethane phase through a phase separating paper in order to remove traces of water.

For vitamin-concentrates and premixes, take an aliquot part of the extract and dilute with 1,2-dichloroethane (3.1) to obtain a menadione concentration of 2 to 10 μ g per ml. For all other feeding stuffs, evaporate to dryness an aliquot part of the extract under reduced pressure in an atmosphere of nitrogen on a water bath at 40° C. Rapidly treat the residue with 1,2-dichloroethane (3.1) to obtain a solution containing 2 to 10 μ g menadione per ml.

5.2 *Hydrazone formation*

Transfer 2.0ml of the dichloroethane extract obtained in accordance with 5.1 to a 10ml graduated flask and add 3ml 2,4-dinitrophenylhydrazine reagent (3.9), securely stopper the flask with a cork or teflon stopper to prevent evaporation and heat for two hours at 70° C on a water bath. Allow to cool, add 3ml ammoniacal ethanol (3.8), mix, make up to volume with absolute ethanol (3.2) and mix again.

5.3 *Determination*

Measure the absorbance of the blue-green complex at a wavelength of 635nm against a reference solution obtained by treating 2ml 1,2-dichloroethane (3.1) as indicated in 5.2.

Determine the quantity of menadione by reference to a calibration curve established for each series of analyses.

5.4 *Calibration curve*

Treat 2ml of the menadione standard solutions (3.10) as described in 5.2. Measure the absorbance as indicated in 5.3. Construct a graph relating the absorbances to the amount of menadione present.

6. Expression of the Results

Calculate the menadione content of the sample by taking account of the weight of the test sample and of the dilutions carried out in the course of analysis. Express the result in mg menadione per kg of the sample.

23. HYDROCYANIC ACID

1. Scope and Field of Application

This method is for the determination of hydrocyanic acid, free and combined in the form of glycosides, in feeding stuffs and in particular in products derived from linseed, manioc flour and certain species of beans.

2. Principle

The sample is suspended in water. The hydrocyanic acid is released by the action of enzymes, separated by steam distillation and collected in a specific volume of acidified silver nitrate solution. The silver cyanide is separated by filtration and the excess silver nitrate is titrated with a solution of ammonium thiocyanate.

3. Reagents

- 3.1 Anti-foam (e.g. silicone).
- 3.2 Nitric acid (d=1.42g/ml).
- 3.3 Ammonia solution. Prepare by diluting one volume of ammonia (d=0.88g/ml) with two volumes of water.
- 3.4 Ammonium ferric sulphate, saturated solution.
- 3.5 Sweet almonds suspension; crush twenty blanched sweet almonds in 100ml water at 37 to 40 ° C. Check that there is no hydrocyanic acid in 10ml of the suspension using sodium picrate paper or by carrying out a blank test as described in the last paragraph of 5.

- 3.6 Sodium acetate solution, neutral to phenolphthalein: 10g sodium acetate, anhydrous, per 100ml.
- 3.7 Ammonium thiocyanate solution, 0.02N.
- 3.8 Silver nitrate solution, 0.02N.

4. Apparatus

- 4.1 Oven regulated at 37-38° C.
- 4.2 Apparatus for steam distillation fitted with a condenser with a curved extension piece.
- 4.3 1,000ml flat-bottomed flasks with ground-glass stoppers.
- 4.4 Oil bath.
- 4.5 Burette graduated to 0.05ml.

5. Procedure

Weigh to the nearest 0.005g, approximately 20g of the prepared sample, place in a 1,000ml flat-bottomed flask (4.3) and add 50ml of water and 10ml of sweet almond suspension (3.5). Stopper the flask and transfer to the oven (4.1) for sixteen hours at 37-38° C. Cool to room temperature, add 80ml of water, 10ml of sodium acetate solution (3.6) and a drop of anti-foam (3.1).

Connect the flask to the steam distillation apparatus (4.2) and place in the oil bath (4.4) which has first been brought to a temperature slightly above 100° C. Distil 200 to 300ml of liquid by passing a current of steam through the flask and gently heating the oil bath. Collect the distillate in an Erlenmeyer flask protected from the light and containing exactly 50ml of silver nitrate solution 0.02N (3.8) and 1ml of nitric acid (3.2). Make sure that the condenser's extension piece is immersed in the silver nitrate solution.

Transfer the contents of the Erlenmeyer flask to a 500ml graduated flask, make up to volume with water, mix and filter. Remove 250ml of the filtrate, add approximately 1ml ammonium ferric sulphate solution (3.4) and titrate the excess silver nitrate with the solution of ammonium thiocyanate 0.02N (3.7). A blank test may, if required, be carried out by applying the same procedure to 10ml of sweet almond suspension (3.5); omitting the sample.

6. Expression of the Results

If the blank test indicates that silver nitrate solution 0.02N has been consumed, subtract the value of this from the volume consumed by the distillate of the sample. 1ml of 0.02N $\text{AgNO}_3 \equiv 0.54\text{mg}$ of HCN. Express the result as a percentage of the sample.

NOTE: If the sample (e.g. beans) contains a large quantity of sulphides a black precipitate of silver sulphide is formed which is filtered together with the silver cyanide deposit. The formation of this precipitate consumes silver nitrate solution and this effect must be allowed for in the calculation of the HCN content. To do this, proceed as follows: treat the deposit left on the filter with 50ml of ammonia (3.3) in order to dissolve the silver cyanide. Wash the residue in dilute ammonia and then determine its silver content. Convert the value obtained into ml of 0.02N silver nitrate solution and subtract this volume from the volume of silver nitrate solution consumed by the sample distillate.

24. VOLATILE MUSTARD OIL

1. Scope and Field of Application

This method is for the determination of volatile mustard oil contained in cakes made from the *Brassica* and *Sinapis* species, and in feeding stuffs which contain cakes made from those species. The steam separated component is expressed as allyl isothiocyanate.

2. Principle

The sample is suspended in water. The volatile mustard oil is released by the action of enzymes, entrained by distillation with ethanol and collected in dilute ammonia. The solution is treated while warm with a given volume of silver nitrate solution, then cooled and filtered. The excess silver nitrate is titrated with a solution of ammonium thiocyanate.

3. Reagents

- 3.1 Anti-foam (e.g. silicone).
- 3.2 Ethanol, 96% (V/V).
- 3.3 Nitric acid ($d=1.42\text{g/ml}$).
- 3.4 White mustard (*Sinapis alba*).
- 3.5 Ammonia solution: prepare by diluting one volume of ammonia ($d=0.88\text{g/ml}$) with two volumes of water.
- 3.6 Ammonium ferric sulphate, saturated solution.
- 3.7 Ammonium thiocyanate solution, 0.1N.
- 3.8 Silver nitrate solution, 0.1N.

4. Apparatus

- 4.1 Flat-bottomed 500ml flasks with ground-glass stoppers.
- 4.2 Distilling apparatus fitted with a condenser and a splash head.

5. Procedure

Weigh to the nearest 0.001g, approximately 10g of the prepared sample and place in a 500ml flat-bottomed flask (4.1) and add 2g of finely ground white mustard (3.4) [an enzyme source] and 200ml water at 20° C. Stopper the flask and keep at 20° C for approximately 2 hours, shaking frequently. Add 40ml ethanol (3.2) and one drop of anti-foam (3.1). Distil approximately 150ml and collect the distillate in a 500ml conical flask containing 20ml ammonia (3.5) making sure that the end of the condenser is immersed in the liquid. Add to the ammoniacal solution 50ml 0.1N silver nitrate solution, (3.8) (or more if necessary), place a small funnel over the neck of the flask and heat the mixture on a steam bath for one hour. Allow to cool, transfer to a 250ml graduated flask rinsing in with water, make up to the mark, mix and filter. To 100ml of the clear filtrate, add 5ml nitric acid (3.3) and approximately 5ml ammonium ferric sulphate solution (3.6). Titrate the excess silver nitrate with the 0.1N ammonium thiocyanate solution (3.7).

Carry out a blank test by applying the same procedure to 2g finely ground white mustard (3.4), omitting the sample.

6. Expression of the Results

Subtract the volume of 0.1N silver nitrate solution consumed in the blank test from that consumed by the sample. The value obtained gives the number of ml of 0.1N silver nitrate solution consumed by the mustard oil in the sample. 1ml of 0.1N $\text{AgNO}_3 \equiv 4.956\text{mg}$ of allyl isothiocyanate. Express the result as allyl isothiocyanate as a percentage of the sample.

25. FREE AND TOTAL GOSSYPOL

1. Scope and Field of Application

This method is for the determination of free gossypol, total gossypol and chemically related substances in seed, flour and cotton seed cake, and feeding stuffs containing these substances. The lower limit of determination is 20mg/kg.

2. Principle

The gossypol is extracted in the presence of 3-aminopropan-1-ol either by a mixture of propan-2-ol and hexane for the determination of free gossypol, or by dimethylformamide for the determination of total gossypol. The gossypol is converted by aniline to gossypol-dianiline, the absorbance of which is measured at 440nm.

3. Reagents

- 3.1 Propan-2-ol/hexane mixture: mix 60 parts by volume propan-2-ol with 40 parts by volume hexane.
- 3.2 Solvent A: place in a 1,000ml graduated flask about 500ml propan-2-ol/hexane mixture (3.1), 2ml 3-aminopropan-1-ol, 8ml glacial acetic acid and 50ml water. Make up the volume with the propan-2-ol/hexane mixture (3.1). This reagent will remain stable for one week.
- 3.3 Solvent B: place in a 100ml graduated flask 2ml 3-aminopropan-1-ol and 10ml glacial acetic acid. Cool to room temperature and make up to volume with dimethylformamide. This reagent will remain stable for one week.
- 3.4 Aniline: if the absorbance of the blank test exceeds 0.022, distil the aniline over zinc dust rejecting the first and last 10% fractions of the distillate. This reagent will keep for several months if refrigerated in a stoppered dark glass flask.
- 3.5 Standard gossypol solution A: place in a 250ml graduated flask 27.9mg gossypol acetate. Dissolve and make up to volume with solvent A (3.2). Place 50ml of this solution in a 250ml graduated flask and make up to volume with solvent A. This solution has a gossypol concentration of 0.02mg/ml. Allow to stand for one hour at room temperature before use.
- 3.6 Standard gossypol solution B: place in a 50ml graduated flask 27.9mg gossypol acetate. Dissolve and make up to volume with solvent B (3.3). This solution has a gossypol concentration of 0.5mg/ml.

Standard gossypol solutions A and B will remain stable for 24 hours if kept away from light.

4. Apparatus

- 4.1 Rotary shaker; 35-40 revolutions per minute.
- 4.2 Spectrophotometer with 10mm cells.

5. Procedure

5.1 Sample for analysis

The weight of sample taken for analysis depends on the supposed level of gossypol in the sample. It is preferable to work on a small sample for analysis together with a relatively large aliquot part of the filtrate, so as to obtain a sufficient quantity of gossypol in order to be able to carry out a precise photometric measurement.

For the determination of free gossypol in seeds, flour and cotton seed cake, the sample for analysis must not exceed 1g; for compound feeding stuffs it may be as much as 5g. A 10ml aliquot part of the filtrate is suitable in most cases; it should contain from 50 to 100 μ g gossypol.

For the determination of total gossypol, the sample for analysis may vary from 0.5 to 5g so that a 2ml aliquot part of the filtrate contains 40 to 20.0 μ g gossypol. The analysis must be carried out at a temperature close to 20° C.

5.2 Determination of free gossypol

Place the prepared sample in a 250ml flask with a ground-glass neck, and cover the bottom of the flask with a layer of glass beads of approximately 6mm diameter. Add 50ml solvent A (3.2) stopper the flask and mix for one hour in the mixer (4.1). Filter through a dry filter and collect the filtrate in a small flask with a ground-glass neck. During filtration cover the funnel with a watch glass. Transfer to two 25ml graduated flasks (A and B) identical aliquot parts of the filtrate containing 50 to 100 μ g gossypol. If necessary make up the volume to 10ml using solvent A (3.2). Then make up to volume the contents of flask (A) with the propan-2-ol/hexane mixture (3.1). This solution is used as a reference solution against which the sample is measured.

Transfer 10ml solvent A (3.2) to each of two other 25ml graduated flasks (C and D). Make up to volume the contents of flask (C) with the propan-2-ol/hexane mixture (3.1). This solution is used as a reference solution against which to measure the blank.

Add 2ml aniline (3.4) to flasks (D) and (B). Heat for 30 minutes on a steam bath to develop the colour. Cool to room temperature, make up to volume with the propan-2-ol/hexane mixture (3.1), mix and allow to stand for one hour.

Measure the absorbance of the blank test solution (D) compared with the solution for reference (C) and the absorbance of the sample solution (B) compared with the solution for reference (A), at a wavelength of 440nm.

Subtract the absorbance of the blank test solution from that of the sample solution (=corrected absorbance). From this value calculate the amount of free gossypol as indicated in 6.

5.3 Determination of total gossypol

Place a prepared sample containing 1 to 5mg gossypol in a 50ml graduated flask and add 10ml solvent B (3.3). At the same time prepare a blank test, placing 10ml solvent B (3.3) in another 50ml graduated flask. Heat the two flasks for 30 minutes on a steam bath. Cool to room temperature and make up the volume of each flask with the propan-2-ol/hexane mixture (3.1). Mix and allow to settle for 10 to 15 minutes, then filter.

Transfer 2ml of the sample filtrate to each of two 25ml graduated flasks, and 2ml of the blank test filtrate to two other 25ml flasks. Take one flask from each pair and make up the volumes of each to 25ml with the propan-2-ol/hexane mixture (3.1). These solutions shall be used for reference.

Add 2ml aniline (3.4) to each of the other two flasks. Heat for 30 minutes on a steam bath to develop the colour. Cool to room temperature, make up to 25 ml with the propan-2-ol/hexane mixture (3.1), mix and allow to stand for 1 hour.

Measure the absorbance as indicated in 5.2. From this value calculate the amount of total gossypol as indicated in 6.

6. Expression of the Results

Results may be calculated either from the specific absorbance (6.1) or by reference to a calibration curve (6.2).

6.1 From the specific absorbance

In the conditions described, the specific absorbances are as follows:

$$\text{free gossypol: } E_{10\text{mm}}^{1\%} = 625$$

$$\text{total gossypol: } E_{10\text{mm}}^{1\%} = 600$$

The amount of free or total gossypol in the sample is given by the following formula:

$$\text{gossypol \%} = \frac{E \times 1,250}{E_{10\text{mm}}^{1\%} \times p \times a}$$

in which:

E=corrected absorbance, determined as indicated in 5.2;

p=sample taken for analysis in grams; and

a=aliquot part of the filtrate in ml.

6.2 From a calibration curve

6.2.1 Free gossypol

Prepare two series of five 25ml graduated flasks. Transfer to each series of flasks respectively 2.0, 4.0, 6.0, 8.0 and 10.0 ml aliquots of standard gossypol solution A(3.5). Make up the volumes to 10ml using

solvent A (3.2). Complete each series with a blank solution consisting of a 25ml graduated flask containing only 10ml solvent A (3.2).

Make up the volumes of the first series to 25 ml (including the blank solution) with the propan-2-ol/hexane mixture (3.1) (reference series).

Add 2ml aniline (3.4) to each flask in the second series (including the blank solution). Heat for 30 minutes on a steam bath to develop the colour. Cool to room temperature, make up to volume with the propan-2-ol/hexane mixture (3.1), mix and allow to stand for 1 hour (standard series).

Measure, under the conditions indicated in 5.2, the absorbances of the solutions in the standard series compared with the corresponding solutions in the reference series. Plot a calibration curve of absorbances against quantities of gossypol (in μg).

6.2.2 Total gossypol

Prepare six 50ml graduated flasks. In the first flask place 10ml solvent B (3.3) and in the others respectively 2.0, 4.0, 6.0, 8.0 and 10.0ml standard gossypol solution B (3.6). Make up the contents of each flask to 10ml using solvent B (3.3). Heat for 30 minutes on a steam bath. Cool to room temperature, make up to volume with the propan-2-ol/hexane mixture (3.1) and mix.

Place 2ml of these solutions respectively in two series of six 25ml graduated flasks. Make up the contents of the flasks in the first series to 25ml using the propan-2-ol/hexane mixture (3.1) (reference series).

Add 2ml aniline (3.4) to each flask in the second series. Heat for 30 minutes on a steam bath. Cool to room temperature, make up to volume with the propan-2-ol/hexane mixture (3.1) mix and allow to stand for 1 hour (standard series).

Under the conditions indicated in 5.2 measure the absorbances of the solutions in the standard series compared with the corresponding solutions in the reference series. Plot the calibration curve of absorbances against quantities of gossypol (in μg).

26a. AFLATOXIN B₁—FOR CERTAIN STRAIGHT FEEDING STUFFS

1. Scope and Field of Application

This method is for the determination of aflatoxin B₁ in the following feeding stuffs only: groundnut, copra, linseed, soya, sesame, babassu palm and maize germ oilcakes, cereals and cereal products, pea meal, potato pulp and starch. The lower limit of determination is 10 $\mu\text{g}/\text{kg}$. Other products should be analysed by the method described under method 26b.

2. Principle

The sample is extracted with chloroform, the extract filtered, and an aliquot portion of the filtrate purified by column chromatography on silica gel. The eluate is evaporated and the residue redissolved in a specific volume of chloroform or of a mixture of benzene and acetonitrile. An aliquot portion of this solution is subjected to thin-layer chromatography. The quantity of aflatoxin B₁ is determined under UV irradiation of the chromatogram, either visually or by fluorodensitometry, by comparison with known quantities of standard aflatoxin B₁. The identity of the aflatoxin B₁ must be confirmed by the procedure indicated.

3. Reagents

NOTE: Aflatoxin is a very hazardous material in view of its carcinogenic nature. It is suggested that particular attention be paid to the decontamination recommendations given in J. Assoc. Off. Anal. Chem. 1965, 48, 681.

- 3.1 Acetone.
- 3.2 Chloroform stabilised with 0.5 to 1.0% of 96% ethanol (V/V).
- 3.3 n-Hexane.
- 3.4 Methanol.
- 3.5 Diethyl ether, anhydrous, free from peroxides.
- 3.6 Mixture of benzene and acetonitrile in the proportions by volume 98+2.
- 3.7 Mixture of chloroform (3.2) and methanol (3.4) in the proportions by volume 97+3.
- 3.8 Silica gel, for column chromatography, particle size 0.05 to 0.20mm.
- 3.9 Absorbent cotton wool, previously degreased with chloroform, or glass wool.
- 3.10 Sodium sulphate, anhydrous, granular.
- 3.11 Inert gas, e.g. nitrogen.
- 3.12 Hydrochloric acid solution, 1N.
- 3.13 Sulphuric acid solution: mix one volume of sulphuric acid ($d=1.84\text{g/ml}$) with one volume of water.
- 3.14 Diatomaceous earth (¹), acid washed.
- 3.15 Silica gel G-HR or equivalent, for TLC.
- 3.16 Standard solution with about $0.1\mu\text{g}$ of aflatoxin B₁ per ml in chloroform (3.2) or the benzene/acetonitrile mixture (3.6), prepared and checked as indicated in 7:
- 3.17 Standard solution for qualitative testing purposes containing about $0.1\mu\text{g}$ of aflatoxin B₁ and B₂ per ml in chloroform (3.2), or benzene/acetonitrile mixture (3.6). These concentrations are given as a guide. They must be adjusted so as to obtain the same intensity of fluorescence for both aflatoxins.
- 3.18 Developing solvents:
 - 3.18.1 Mixture of chloroform (3.2) and acetone (3.1) in the proportions by volume 9+1, unsaturated tank;
 - 3.18.2 mixture of diethyl ether (3.5) and methanol (3.4) and water in the proportions by volume 96+3+1, unsaturated tank;
 - 3.18.3 mixture of diethyl ether (3.5) and methanol (3.4) and water in the proportions by volume 94+4.5+1.5, saturated tank;
 - 3.18.4 mixture of chloroform (3.2) and methanol (3.4) in the proportions by volume 94+6, saturated tank;
 - 3.18.5 mixture of chloroform (3.2) and methanol (3.4) in the proportions by volume 97+3, saturated tank.

4. Apparatus

- 4.1 Glass tube for chromatography (internal diameter: 22mm; length: 300mm), with a PTFE stop-cock and a 250ml reservoir.
- 4.2 Rotary evaporator, with inlet for inert gas and a 500ml round-bottomed flask.
- 4.3 TLC apparatus.
- 4.4 Glass plates for TLC, 200×200mm, prepared as follows (the quantities indicated are sufficient to cover five plates):

put 30g of silica gel G-HR (3.15) into a conical flask. Add 60ml water, stopper and shake for a minute. Spread the suspension on the plates so as to obtain a uniform layer 0.25mm thick. Leave to dry in the air and then store in a desiccator containing silica gel. At the time of use, activate the plates by keeping them in an oven at 110° C for one hour. Ready-to-use plates are suitable if they give results similar to those obtained with the plates prepared as indicated above.

(¹) Hyflosupercel or equivalent.

- 4.5 UV lamp, wavelength 365nm. The intensity of irradiation must make it possible for a spot of 1 nanogram of aflatoxin B₁ to be clearly distinguishable on a TLC plate at a distance of 100mm from the lamp.
- 4.6 10ml graduated tubes with polyethylene stoppers.
- 4.7 UV spectrophotometer with 10mm silica cells.
- 4.8 Fluorodensitometer (optional).

5. Procedure

5.1 Defatting

Samples containing more than 5% oil or fat must be defatted with light petroleum (boiling range 40-60° C) before the material is ground and sieved as described under Method 1 (Preparation of the sample for analysis). In such cases the analytical results must be expressed in terms of the weight of the non-defatted sample.

5.2 Extraction

Put 50.0g of the prepared sample into a 500ml conical flask. Add 25g of diatomaceous earth (3.14), 25ml of water and 250ml of chloroform (3.2). Stopper the flask, shake or stir for 30 minutes and filter through a fluted filter paper⁽¹⁾. Discard the first 10ml of the filtrate and then collect 50ml.

5.3 Column clean-up

Insert into the lower end of a chromatography tube (4.1) with tap closed a cotton or glass wool plug (3.9), fill two-thirds of the tube with chloroform (3.2) and add 5g of sodium sulphate (3.10). Check that the upper surface of the sodium sulphate is flat, then add 10g of silica gel (3.8) in small portions. Stir carefully after each addition to eliminate air-bubbles. Allow to stand for 15 minutes and then carefully add 15g of sodium sulphate (3.10). Let the liquid fall until it is just above the upper surface of the sodium sulphate layer. Mix the 50ml of extract collected in 5.2 with 100ml of hexane (3.3) and quantitatively transfer the mixture to the column. Allow the liquid to fall until it is just above the upper surface of the sodium sulphate layer. Discard this eluate. Then add 100ml of diethyl ether (3.5) and again allow it to fall to the upper surface of the sodium sulphate layer. During these operations adjust the rate of flow to 8-12ml per minute and ensure that the column does not run dry. Discard the eluate. Finally elute with 150ml of the chloroform/methanol mixture (3.7) and collect the whole of this eluate. Evaporate the latter almost to dryness in the rotary evaporator (4.2) at a temperature not exceeding 50° C, under a stream of inert gas (3.11). Quantitatively transfer the residue, using chloroform (3.2), to a 10ml graduated tube (4.6). [Note: chloroform may be unsuitable for some residues in which case benzene/acetonitrile (3.6) should be used.] Concentrate the solution under a stream of inert gas (3.11) and then adjust the volume to 2 ml with chloroform (3.2) or benzene/acetonitrile mixture (3.6).

5.4 Thin-layer chromatography

Spot on a TLC plate (4.4), 20mm from the lower edge and at intervals of 20mm the volumes indicated below of the standard solution and the extract:
—10, 15, 20, 30 and 40μl of the standard aflatoxin B₁ solution (3.16);
—10μl of the extract obtained in 5.3 and, superimposed on the same point, 20μl of the standard solution (3.16); and
—10 and 20μl of the extract obtained in 5.3.

The spots obtained must have a diameter of about 5mm. Dry in a slow stream of air. Develop the chromatogram in the dark with one of the developing solvents (3.18). The choice of the solvent must be made beforehand, by depositing 25μl of the qualitative standard solution (3.17) on a plate and checking that, when developed, aflatoxin B₁ and B₂ are completely separated. Remove the plate from the tank and allow the solvents to evaporate in the dark and then irradiate with UV light, placing the plate 100mm from the lamp (4.5). The spots of aflatoxin B₁ give a blue fluorescence.

(¹) Whatman No. 1 or equivalent.

5.5 *Quantitative determination*

Determine either visually or by fluorodensitometry as indicated below.

5.5.1 *Visual measurements*

Determine the quantity of aflatoxin B₁ in the extract by matching the fluorescence intensity of the extract spots with that of one of the standard solution spots; interpolate if necessary. The fluorescence obtained by the superimposition of the extract on the standard solution must be more intense than that of the 10 μ l of extract and there must not be more than one visible spot. If the fluorescence intensity given by the 10 μ l of extract is greater than that of the 40 μ l of standard solution, dilute the extract 10 or 100 times with chloroform (3.2) or benzene/acetonitrile mixture (3.6) before subjecting it again to thin-layer chromatography.

5.5.2 *Measurement by fluorodensitometry*

Measure the fluorescence intensity of the aflatoxin B₁ spots with the fluorodensitometer (4.8) at an excitation wavelength of 365nm and an emission wavelength of 443nm. Determine the quantity of aflatoxin B₁ in the extract spots by comparison of their fluorescence intensities with that of the standard aflatoxin B₁ spots.

5.6 *Confirmation of the identity of aflatoxin B₁*

Confirm the identity of the aflatoxin B₁ in the extract by the procedures indicated below.

5.6.1 *Treatment with sulphuric acid*

Spray the chromatogram obtained in 5.4 with sulphuric acid (3.13). The fluorescence of the aflatoxin B₁ spots after spraying with sulphuric acid must be yellow under UV irradiation.

5.6.2 *Two dimensional chromatography involving the formation of aflatoxin B₁-hemiacetal (aflatoxin B_{2a})*

N.B.—The operations described below must be carried out following carefully the diagram in fig. 1.

5.6.2.1 *Application of the solutions*

Score two straight lines on a TLC plate (4.4) parallel to two contiguous sides (60mm in from each side) to limit migration of the solvent fronts. Spot the following solutions on the plate using capillary pipettes or microsyringes:

- on point A: a volume of purified extract of the sample, obtained in 5.3 containing about 2.5 nanograms of aflatoxin B₁;
- on points B and C: 25 μ l of the standard solution (3.16).

5.6.2.2 *Development*

Develop the chromatogram in direction I, in the dark, using the developing solvent (3.18.1) (10mm depth of solvent in an unsaturated tank) until the solvent front reaches the solvent limit line. Remove the plate from the tank and allow to dry in the dark at ambient temperature for five minutes. Cover the plate with a glass sheet so that a band 25mm wide, containing points A and B, is left exposed (indicated by the hatched area in fig. 1). Spray the exposed band with hydrochloric acid (3.12) until it darkens, the cover sheet is overlaid with a sheet of filter paper to absorb excess hydrochloric acid. Allow to react for 10 minutes in the dark and dry with a stream of air at ambient temperature. Develop the chromatogram in direction II, in the dark, using the developing solvent (3.18.1) (10mm layer in an unsaturated tank) until the solvent front reaches the solvent limit line. Remove the plate from the tank and allow to dry at ambient temperature.

5.6.2.3 *Interpretation of the chromatogram*

Examine the chromatogram under UV light (4.5) and check for the following features:

- (a) appearance of a blue fluorescent spot of aflatoxin B₁ originating from the standard solution applied at C (migration in direction I);
- (b) appearance of a blue fluorescent spot of unreacted (with the hydrochloric acid) aflatoxin B₁ and a more intense blue fluorescent spot of aflatoxin B₁-hemiacetal, both originating from the standard solution applied at B (migration in direction II); and
- (c) appearance of spots matching those described in (b), originating from the sample extract applied at A. The position of these spots is defined first by the migration distance of the aflatoxin B₁ from point A in direction I (same as that travelled by the standard applied at C), and then by the migration distances from there in direction II of the aflatoxin B₁-hemiacetal (same as those travelled by the standard applied at B). The fluorescence intensities of hemiacetal spots originating from the extract and from the standard applied at B should match.

6. Expression of the Results

6.1 From the visual measurements

The content in micrograms of aflatoxin B₁ per kg of sample is given by the formula $\frac{R \times Y \times V}{W \times Z}$ where:

Y and Z are respectively the volumes in microlitres of the standard solution of aflatoxin B₁ (3.16) and of the extract having a similar intensity of fluorescence;

R=concentration in micrograms of aflatoxin B₁ per ml in the standard solution (3.16);

V=final volume of the extract in microlitres, allowing for any dilution that was necessary; and

W=weight in grams of the sample corresponding to the volume of extract subjected to column clean-up.

6.2 From the fluorodensitometric measurements

The content in micrograms of aflatoxin B₁ per kg of sample is given by the formula $\frac{S \times V}{W \times Z}$ where:

Z=volume in microlitres of the extract spotted on the plate;

S=quantity in nanograms of aflatoxin B₁ in the extract spot, 10 or 20 μ l related to Y deduced from the measurements;

V=final volume of the extract in microlitres, allowing for any dilution that was necessary; and

W=weight in grams of the sample corresponding to the volume of extract subjected to column clean-up.

7. Preparation and Testing of the Standard Solution (3.16)

7.1 Determination of the concentration of aflatoxin B₁

Caution: Aflatoxin solid is a most hazardous material and analysts are urged to minimise the handling of it in this form. The use of stock solutions, wherever possible, is recommended. See also note under 'Reagents' (3.).

Prepare a standard solution of aflatoxin B₁ in chloroform (3.2) or benzene/acetonitrile mixture (3.6) with a concentration of 8 to 10 μ g per ml. Determine the absorption spectrum between 330 and 370nm. Measure the absorbance (A) at 363nm in the case of the chloroform solution; or at 348nm in the case of the solution in benzene/acetonitrile mixture. Calculate the concentration in micrograms of aflatoxin B₁ per ml of solution from the formulae below:

$$\frac{312 \times A \times 1,000}{20,600} \text{ for the chloroform solution;}$$

$$\frac{312 \times A \times 1,000}{19,800} \text{ for the solution in the benzene/acetonitrile mixture.}$$

Dilute as appropriate, away from daylight, to obtain a working standard solution with a concentration of aflatoxin B₁ of about 0.1 µg per ml. If kept in a refrigerator at 4° C, this solution is stable for two weeks.

7.2 *Testing of chromatographic purity*

Spot on a plate (4.4) 5 µl of the standard solution of aflatoxin B₁ containing 8 to 10 µg/ml (7.1). Develop the chromatogram as indicated in 5.4. In UV light the chromatogram should show only one spot and no fluorescence must be perceptible in the original deposit zone.

8. Observations on Reproducibility of Results

The variation between the results obtained by two or more laboratories on the same sample has been estimated at:

±50% of the mean value for mean values of aflatoxin B₁ greater than 10 and up to and including 20 µg/kg;

±10 µg/kg on the mean value for mean values greater than 20 and up to and including 50 µg/kg; and

±20% of the mean value for mean values above 50 µg/kg.

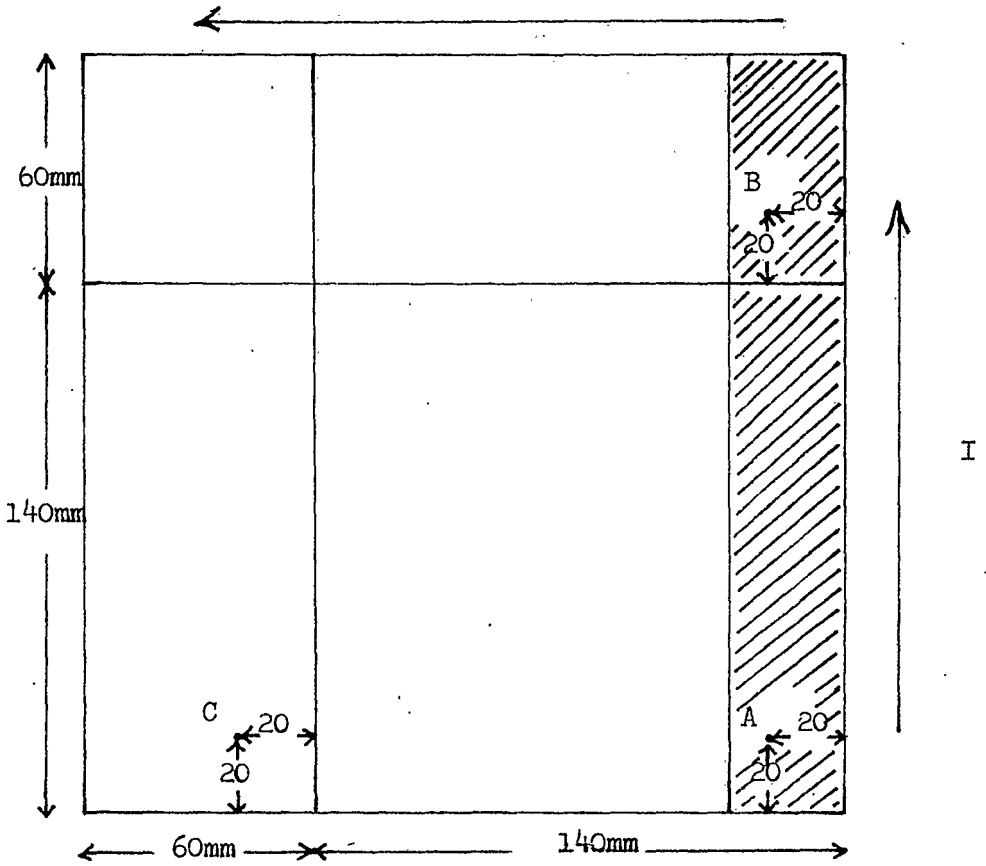

Fig. 1
Secure plate with B in top right hand corner
when spraying with hydrochloric acid.

26b. AFLATOXIN B₁—FOR ALL OTHER FEEDING STUFFS

1. Scope and Field of Application

This method is for the determination of aflatoxin B₁ in feeding stuffs not falling within the scope of method 26a. The lower limit of determination is 10 µg/kg. The method is not applicable to feeding stuffs containing citrus pulp.

2. Principle

The sample is subjected to extraction with chloroform, the extract filtered, and an aliquot portion of the filtrate purified by column chromatography on silica gel. The eluate is evaporated and the residue redissolved in a specific volume of chloroform or of a mixture of benzene and acetonitrile. An aliquot portion of this solution is subjected to two-dimensional thin-layer chromatography. The quantity of aflatoxin B₁ is determined under UV irradiation of the chromatogram, either visually or by fluorodensitometry, by comparison with known quantities of standard aflatoxin B₁. The identity of the aflatoxin B₁ must be confirmed by the procedure indicated.

3. Reagents

NOTE: Aflatoxin is a very hazardous material in view of its carcinogenic nature. It is suggested that particular attention be paid to the decontamination recommendations given in J. Assoc. Off. Anal. Chem. 1965, 48, 681.

- 3.1 Acetone.
- 3.2 Chloroform, stabilised with 0.5 to 1.0% of 96% ethanol (V/V).
- 3.3 n-Hexane.
- 3.4 Methanol.
- 3.5 Diethyl ether, anhydrous, free from peroxides.
- 3.6 Mixture of benzene and acetonitrile in the proportions by volume 98+2.
- 3.7 Mixture of chloroform (3.2) and methanol (3.4) in the proportions by volume 97+3.
- 3.8 Silica gel, for column chromatography, particle size 0.05 to 0.20mm.
- 3.9 Absorbent cotton wool, previously degreased with chloroform, or glass wool.
- 3.10 Sodium sulphate, anhydrous, granular.
- 3.11 Inert gas, e.g. nitrogen.
- 3.12 Hydrochloric acid solution, 1N.
- 3.13 Sulphuric acid solution: mix one volume of sulphuric acid (d=1.84 g/ml) with one volume of water.
- 3.14 Diatomaceous earth (*), acid washed.
- 3.15 Silica gel G-HR or equivalent, for TLC.
- 3.16 Standard solution with about 0.1 µg aflatoxin B₁ per ml in chloroform (3.2) or benzene/acetonitrile mixture (3.6), prepared and checked as described in 7. of Method 26a.
- 3.17 Developing solvents.
 - 3.17.1 Mixture of diethyl ether (3.5) and methanol (3.4) and water in the proportions by volume 94+4.5+1.5, saturated tank.
 - 3.17.2 Mixture of chloroform (3.2) and acetone (3.1) in the proportions by volume 9+1, unsaturated tank.

4. Apparatus

4.1 Glass tube for chromatography (internal diameter: 22mm; length: 300mm), with a PTFE stop-cock and a 250ml reservoir.

(*) Hyflosupercel or equivalent.

- 4.2 Rotary evaporator, with inlet for inert gas and a 500ml round-bottomed flask.
- 4.3 TLC apparatus.
- 4.4 Glass plates for TLC, 200×200mm, prepared as follows (the quantities indicated are sufficient to cover five plates): put 30g of silica gel G-HR (3.15) into a conical flask. Add 60ml water, stopper and shake for a minute. Spread the suspension on the plates so as to obtain a uniform layer 0.25mm thick. Leave to dry in the air and then store in a desiccator containing silica gel. At the time of use, activate the plates by keeping them in an oven at 110° C for one hour. Ready-to-use plates are suitable if they give results similar to those obtained with the plates prepared as indicated above.
- 4.5 UV lamp, wavelength 365nm. The intensity of irradiation must make it possible for a spot of 1 nanogram of aflatoxin B₁ to be clearly distinguished on a TLC plate at a distance of 100mm from the lamp.
- 4.6 10ml graduated tubes with polyethylene stoppers.
- 4.7 UV spectrophotometer with 10mm silica cells.
- 4.8 Fluorodensitometer (optional).

5. Procedure

5.1 Defatting

Samples containing more than 5% oil or fat must be defatted with light petroleum (boiling range 40–60° C) before the material is ground and sieved as described under Method 1 (Preparation of the sample for analysis). In such cases the analytical results must be expressed in terms of the weight of the non-defatted sample.

5.2 Extraction

Put 50.0g of prepared sample into a 500ml conical flask. Add 25g of diatomaceous earth (3.14), 25ml of water and 250ml of chloroform (3.2). Stopper the flask, shake or stir for 30 minutes and filter through a fluted paper⁽¹⁾. Discard the first 10ml of the filtrate and then collect 50ml.

5.3 Column clean-up

Insert into the lower end of a chromatography tube (4.1) with tap closed a cotton or glass wool plug (3.9), fill two-thirds of the tube with chloroform (3.2) and add 5g of sodium sulphate (3.10). Check that the upper surface of the sodium sulphate is flat, then add 10g of silica gel (3.8) in small portions. Stir carefully after each addition to eliminate air-bubbles. Allow to stand for 15 minutes and then carefully add 15g of sodium sulphate (3.10). Let the liquid fall until it is just above the upper surface of the sodium sulphate layer.

Mix the 50ml of extract collected in 5.2 with 100ml of hexane (3.3) and quantitatively transfer the mixture to the column.

Allow the liquid to fall until it is just above the upper surface of the sodium sulphate layer. Discard this eluate. Then add 100ml of diethyl ether (3.5) and again allow it to fall to the upper surface of the sodium sulphate layer. During these operations adjust the rate of flow to 8–12ml per minute and ensure that the column does not run dry. Discard the eluate. Finally elute with 150ml of the chloroform/methanol mixture (3.7) and collect the whole of this eluate. Evaporate the latter almost to dryness in the rotary evaporator (4.2) at a temperature not exceeding 50° C, under a stream of inert gas (3.11).

Quantitatively transfer the residue, using chloroform (3.2), to a 10ml graduated tube (4.6). (Note: chloroform may be unsuitable for some residues in which case benzene/acetonitrile (3.6) should be used.) Concentrate the solution under a stream of inert gas (3.11) and then adjust the volume to 2ml with chloroform (3.2) or benzene/acetonitrile mixture (3.6).

⁽¹⁾ Whatman No. 1 or equivalent.

5.4 Two dimensional thin-layer chromatography

5.4.1 Application of the solution (follow the diagram in fig. 2)

Score two straight lines on a plate (4.4) parallel to two contiguous sides (50mm and 60mm from each side respectively), to limit migration of the solvent fronts. Spot the following solutions on the plate:

- on point A, 20 μ l of the purified sample extract obtained in 5.3;
- on point B, 20 μ l of the standard solution (3.16);
- on point C, 10 μ l of the standard solution (3.16);
- on point D, 20 μ l of the standard solution (3.16); and
- on point E, 40 μ l of the standard solution (3.16).

Dry in a slow stream of air or inert gas (3.11). The spots obtained must have a diameter of about 5mm.

5.4.2 Development (following the diagram in fig. 2)

Develop the chromatogram in direction I, in the dark, using the developing solvent (3.17.1) (10mm layer in a saturated tank) until the solvent front reaches the limit line.

Remove the plate from the tank and allow to dry, in the dark, at ambient temperature for 15 minutes.

Develop the chromatogram in direction II, in the dark, using the developing solvent (3.17.2) (10mm layer in an unsaturated tank) until the solvent front reaches the limit line. Remove the plate from the tank and allow to dry, in the dark, at ambient temperature.

5.4.3 Interpretation of the chromatogram (follow the diagram in fig. 3)

Irradiate the chromatogram with UV light by placing the plate 100 mm from the lamp (4.5). Locate the position of the blue fluorescent spots B, C, D and E of the aflatoxin B₁ from the standard solution. Project two imaginary lines passing through these spots and at right angles to the development directions. The intersection P of these lines is the location in which to expect to find the aflatoxin B₁ spot originating from the sample extract applied at A (fig. 2). However, the actual location of the aflatoxin B₁ spot may be at a point Q at the intersection of two imaginary straight lines forming an angle of about 100° between them and passing through spots B and C respectively. Determine the quantity of aflatoxin B₁ in the sample extract as indicated in 5.5.

5.4.4 Supplementary chromatography

Score two straight lines on a new plate (4.4) parallel to two contiguous sides, as indicated on the diagram in fig. 2, and apply on point A (fig. 2) 20 μ l of the purified sample extract obtained in 5.3 and, superimposed on it, 20 μ l of the standard solution (3.16). Develop as indicated in 5.4.2. Irradiate the chromatogram with UV light (4.5) and check for the following features:

- (a) the aflatoxin B₁ spots from the extract and the standard solution are superimposed; and
- (b) the fluorescence of this spot is more intense than that of the aflatoxin B₁ spot developed at Q on the first plate.

5.5 Quantitative determinations

Determine either visually or by fluorodensitometry as indicated below.

5.5.1 Visual measurements

Determine the quantity of aflatoxin B₁ in the extract by matching the fluorescence intensity of the extract spot with one of the standard solution spots (C, D or E); interpolate if necessary. If the fluorescence intensity given by the 20 μ l of extract is greater than that of the 40 μ l of standard solution, dilute the extract 10 or 100 times with chloroform (3.2) or benzene/acetonitrile mixture (3.6) before subjecting it again to thin-layer chromatography.

5.5.2 *Measurements by fluorodensitometry*

Measure the fluorescence intensity of the aflatoxin B₁ spots with the fluorodensitometer (4.8), using an excitation wavelength of 365nm and an emission wavelength of 443nm. Determine the quantity of aflatoxin B₁ in the extract spot by comparison of its fluorescence intensity with that of the standard aflatoxin B₁ spots.

5.6 *Confirmation of the identity of aflatoxin B₁*

Confirm the identity of the aflatoxin B₁ in the extract by the procedures indicated below.

5.6.1 *Treatment with sulphuric acid*

Spray the chromatogram obtained in 5.4 with sulphuric acid (3.13). The fluorescence of the aflatoxin B₁ spots after spraying with sulphuric acid must be yellow under UV irradiation.

5.6.2 *Two dimensional chromatography involving the formation of aflatoxin B₁-hemiacetal (aflatoxin B_{2a})*

N.B.: The operations described below must be carried out following carefully the diagram in fig. 1.

5.6.2.1 *Application of the solutions*

Score two straight lines on a TLC plate (4.4) parallel to two contiguous sides (60mm in from each side) to limit migration of the solvent fronts. Spot the following solutions on the plate using capillary pipettes or microsyringes:

—on point A: a volume of purified extract of the sample, obtained in 5.3 containing about 2.5 nanograms of aflatoxin B₁ and

—on points B and C: 25μl of the standard solution (3.16).

5.6.2.2 *Development*

Develop the chromatogram in direction I, in the dark, using the developing solvent (3.17.1) (10mm depth of solvent in an unsaturated tank) until the solvent front reaches the limit line. Remove the plate from the tank and allow to dry in the dark at ambient temperature for five minutes. Cover the plate with a glass sheet so that a band 25mm wide, containing points A and B, is left exposed (indicated by the hatched area in fig. 1). Spray the exposed band with hydrochloric acid (3.12) until it darkens, the cover sheet is overlaid with a sheet of filter paper to absorb excess hydrochloric acid. Allow to react for 10 minutes in the dark and dry with a stream of air at ambient temperature.

Develop the chromatogram in direction II, in the dark, using the developing solvent (3.17.1) (10mm layer in an unsaturated tank) until the solvent front reaches the limit line. Remove the plate from the tank and allow to dry at ambient temperature.

5.6.2.3 *Interpretation of the chromatogram*

Examine the chromatogram under UV light (4.5) and check for the following features:

- (a) appearance of a blue fluorescent spot of aflatoxin B₁ originating from the standard solution applied at C (migration in the direction I);
- (b) appearance of a blue fluorescent spot of unreacted (with the hydrochloric acid) aflatoxin B₁ and a more intense blue fluorescent spot of aflatoxin B₁-hemiacetal, both originating from the standard solution applied at B (migration in direction II); and
- (c) appearance of spots matching those described in (b), originating from the sample extract applied at A. The position of these spots is defined first by the migration distance of the aflatoxin B₁ from point A in direction I (same as that travelled by the standard applied at C),

and then by the migration distance from there in direction II of the aflatoxin B₁-hemiacetal (same as those travelled by the standard applied at B). The fluorescence intensities of hemiacetal spots originating from the extract and from the standard applied at B should match.

6. Expression of the Results

6.1 From the visual measurements

The content in micrograms of aflatoxin B₁ per kg of sample is given by the formula:

$$\frac{R \times Y \times V}{W \times Z}$$

where:

Y and Z are respectively the volumes in microlitres of the standard solution of aflatoxin B₁ (3.16) and of the extract having a similar intensity of fluorescence;

R=concentration in micrograms of aflatoxin B₁ per ml in the standard solution (3.16);

V=final volume of the extract in microlitres, allowing for any dilution that was necessary; and

W=weight in grams of the sample corresponding to the volume of extract subjected to column clean-up.

6.2 From the fluorodensitometric measurements

The content in micrograms of aflatoxin B₁ per kg of sample is given by the formula:

$$\frac{S \times V}{W \times Z}$$

where:

Z=volume in microlitres of the extract spotted on the plate;

S=quantity in nanograms of aflatoxin B₁ in the extract spot, 10 or 20 μl related to Y deduced from the measurements;

V=final volume of the extract in microlitres, allowing for any dilution that was necessary; and

W=weight in grams of the sample corresponding to the volume of extract subjected to column clean-up.

7. Observations on Reproducibility of Results

The variation between the results obtained by two or more laboratories on the same sample has been estimated at:

±50% of the mean value for mean values of aflatoxin B₁ greater than 10 and up to and including 20 μg/kg;

±10 μg/kg on the mean value for mean values greater than 20 and up to and including 50 μg/kg; and

±20% of the mean value for mean values above 50 μg/kg.

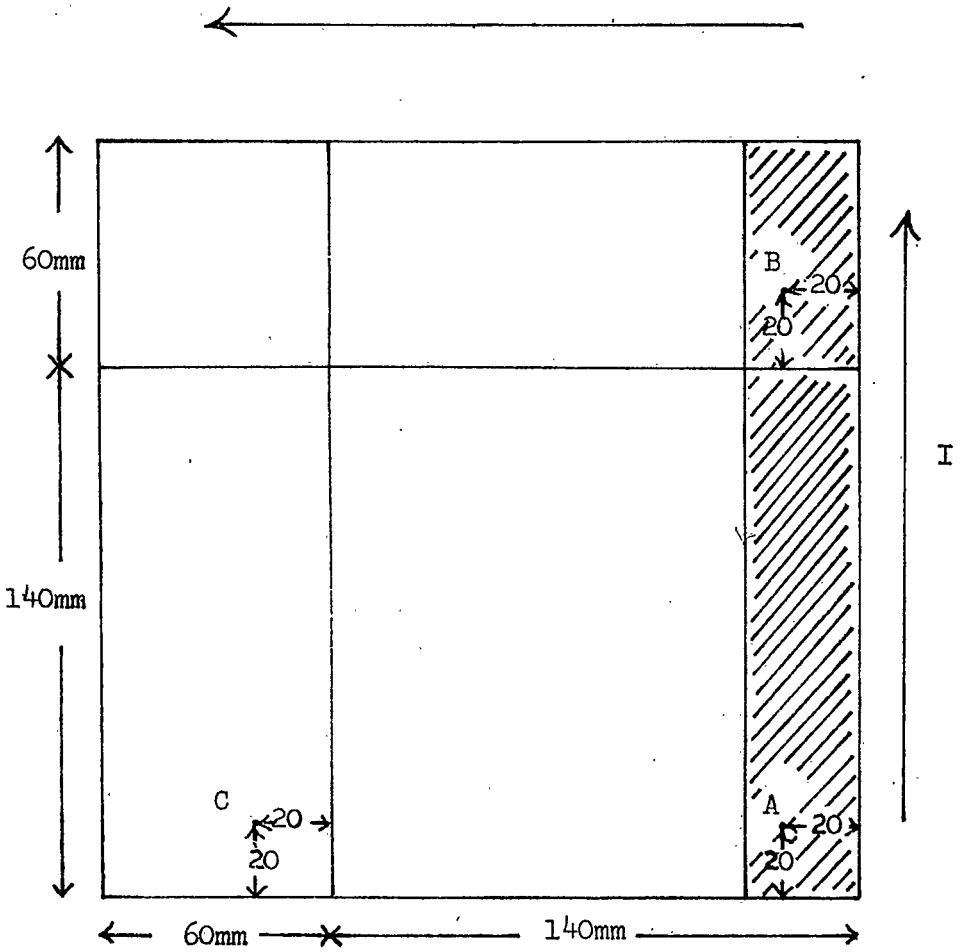

Fig. 1
Secure plate with B in top right hand corner
when spraying with hydrochloric acid.

II

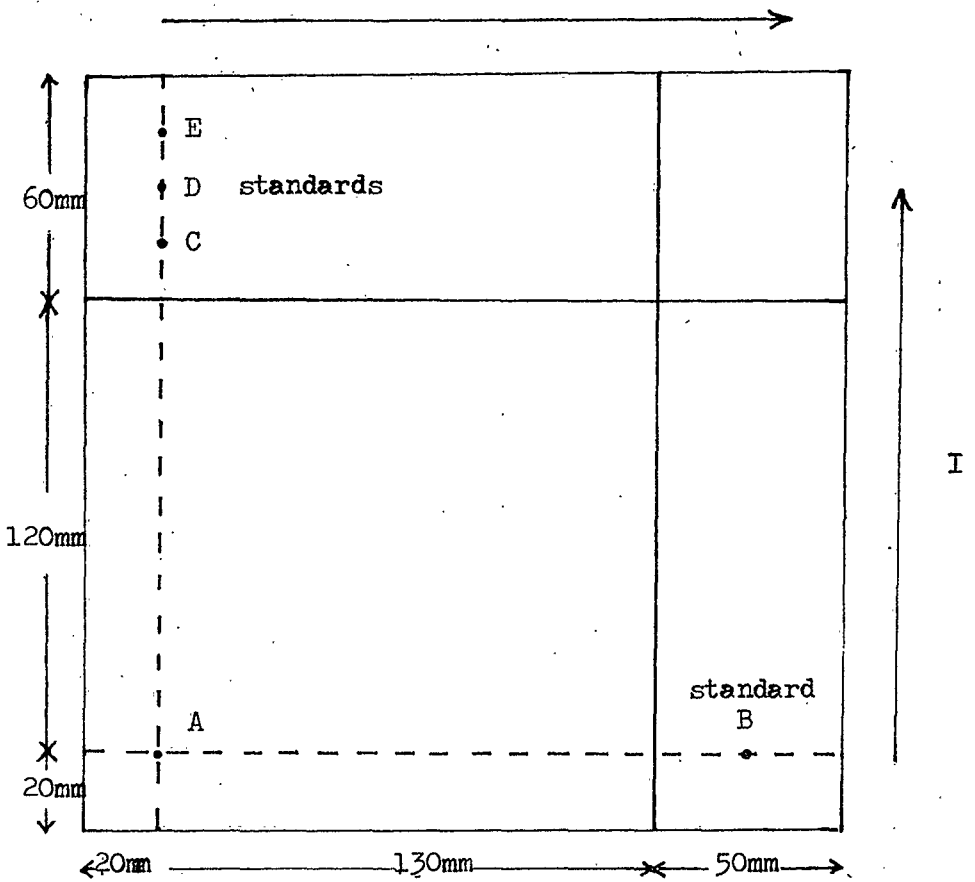

Fig. 2

II

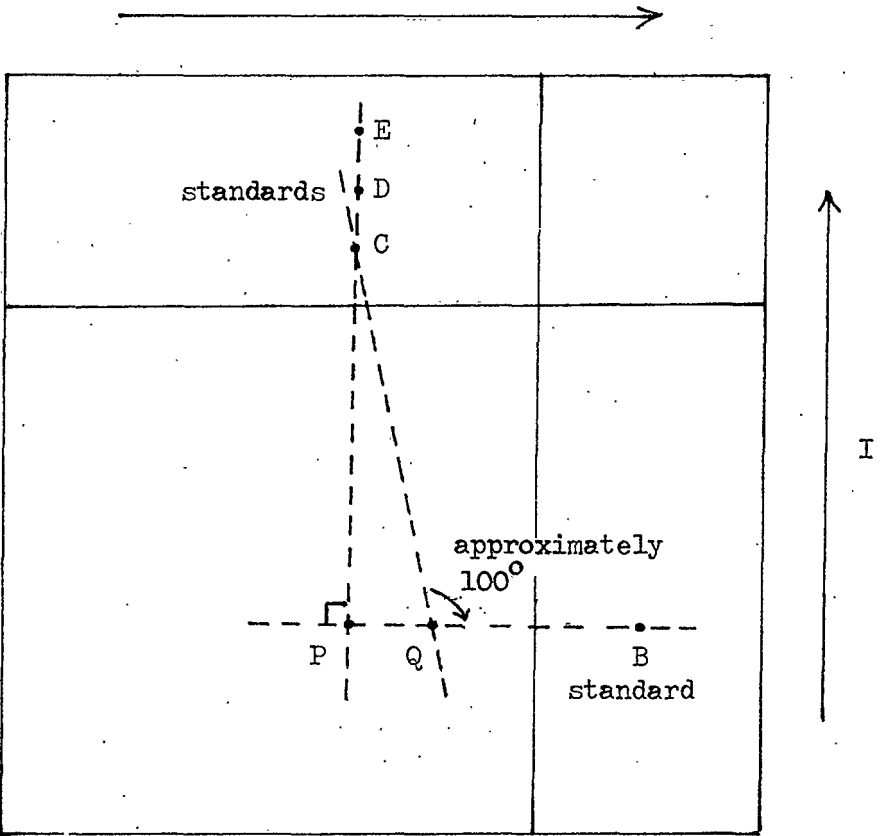

Fig. 3

27. CARBONATES

1. Scope and Field of Application

This method is for the determination of the carbonate content, expressed as calcium carbonate, of feeding stuffs. This method should not be used in certain cases where, for example, iron carbonate is present.

2. Principle

The sample is treated with hydrochloric acid and the carbon dioxide released is collected in a graduated tube, and its volume compared with that released by a known quantity of calcium carbonate under the same conditions.

3. Reagents

- 3.1 Hydrochloric acid solution, approximately 6N.
- 3.2 Calcium carbonate.
- 3.3 Sulphuric acid solution, approximately 0.1N, coloured with methyl red.

4. Apparatus

Scheibler-Diétrich apparatus (fig. 1) or equivalent apparatus.

5. Procedure

The quantity of sample taken for analysis depends on the supposed level of carbonate in the sample: 0.5g sample for contents from 50 to 100% of carbonate, expressed as calcium carbonate; 1g sample for contents from 40 to 50% of carbonate, expressed as calcium carbonate; 2 to 3g for contents less than 40%.

Weigh to the nearest 0.001g, the appropriate quantity of prepared sample and transfer to the special flask (D) of the apparatus provided with a small tube of unbreakable material containing 10ml hydrochloric acid (3.1). Connect the flask to the apparatus and turn the three-way tap (E) so that the tube (A) connects with the outside. Adjust the height of the mobile tube (B) containing coloured sulphuric acid (3.3) to bring the level of the liquid in the graduated tube (A) to the zero mark. Turn the tap (E) in order to connect tube (A) with tube (C) and check that the level is zero.

Tilt the flask (D) and slowly run the hydrochloric acid (3.1) over the sample. Equilibrate the pressure by lowering the tube (B). Shake the flask (D) until the evolution of carbon dioxide has ceased completely. Restore pressure by bringing the liquid back to the same level in tubes (A) and (B). Allow the volume of gas to become constant (several minutes) and then take the reading. Carry out a control test using 0.5g of calcium carbonate under the same conditions.

For samples greater than 2g, first mix with 15ml distilled water before beginning the test. Use the same volume of distilled water for the control test.

If the apparatus used has a different volume from that of the Scheibler-Diétrich apparatus, the quantity of sample and calcium carbonate taken must be adjusted accordingly.

6. Expression of the Results

Calculate the percentage of carbonates in the sample expressed as calcium carbonate, using the formula:

$$\frac{V \times 100}{T \times 2 \times W}$$

where:

V = volume of carbon dioxide (ml) released by the sample;

T = volume of carbon dioxide (ml) released by 0.5g calcium carbonate; and

W = weight of sample taken (g).

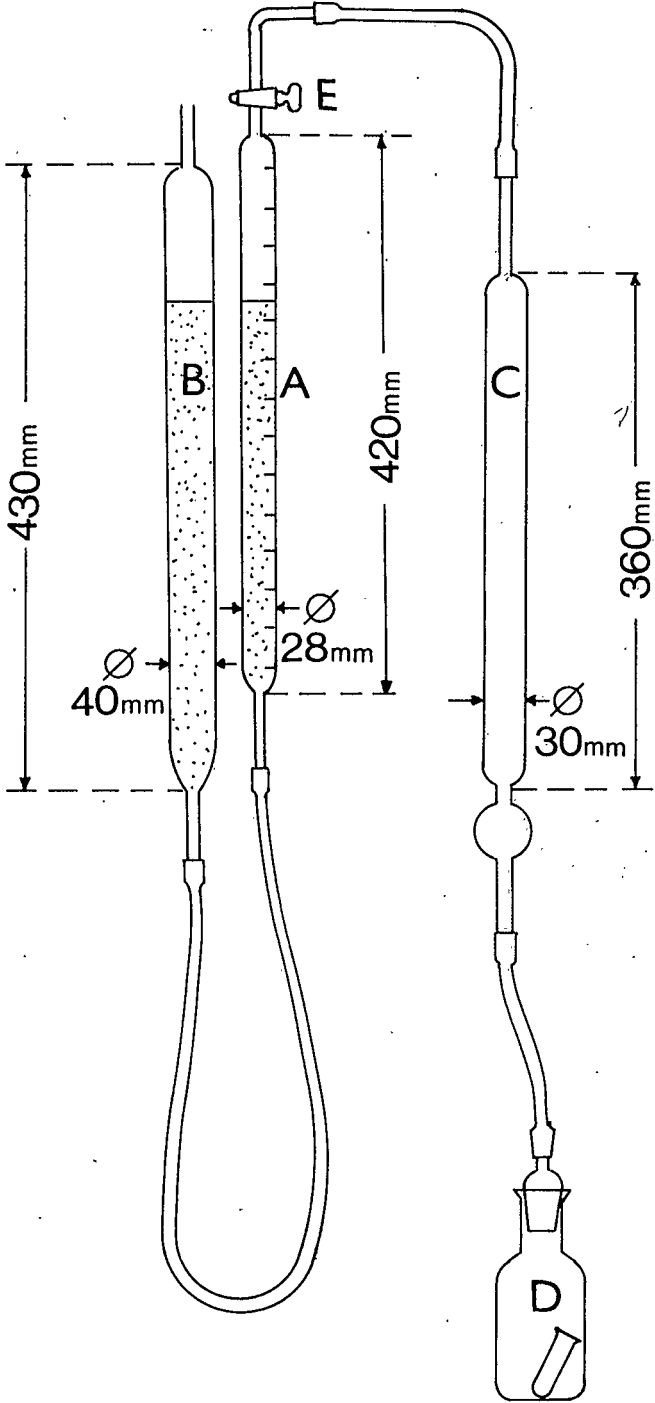

Fig. 1

28. SODIUM

1. Scope and Field of Application

This method is for the determination of sodium in feeding stuffs.

2. Principle

The sample is ashed and the residue treated with hydrochloric acid. The sodium content of the solution is determined by flame photometry.

3. Reagents

- 3.1 Hydrochloric acid, diluted: mix two volumes of hydrochloric acid ($d=1.18\text{g/ml}$) with one volume of water.
- 3.2 Releasing agent: dissolve 50g caesium chloride and 250g aluminium nitrate $[\text{Al}(\text{NO}_3)_3 \cdot 9\text{H}_2\text{O}]$ in water, dilute to 1,000ml and mix. Store in a plastic bottle.
- 3.3 Sodium standard solution: dissolve 2.542g sodium chloride in water, add 5ml hydrochloric acid (3.1), dilute to 1,000ml and mix. Store in a plastic bottle. 1ml of this solution \equiv 1mg sodium (Na).

4. Apparatus

- 4.1 Platinum, silica or porcelain crucibles, provided with lids.
- 4.2 Muffle furnace capable of being maintained at 450°C .
- 4.3 Flame photometer.

5. Procedure

5.1 Dissolution of sample and determination

Weigh to the nearest 0.01g, approximately 10g of the prepared sample into a crucible (4.1) and ash at 450°C for three hours; avoid ignition of the sample. Allow to cool and transfer the ash quantitatively to a 500ml graduated flask, (it is recommended that borosilicate rather than soda glass is used, in case of reaction) using 250 to 300ml water and then 50ml hydrochloric acid (3.1). If no organic matter is present, the sample should be dissolved directly without ashing. When the release of carbon dioxide has ceased, heat the solution and maintain at 90°C for two hours, stirring occasionally. Cool to room temperature, dilute to the mark with water, shake and filter. Transfer an aliquot containing not more than 1mg sodium to a 100ml graduated flask, add 10ml releasing agent (3.2), dilute to the mark with water and mix. For higher levels of sodium, dilute the solution by an appropriate amount before adding the releasing agent.

The table below is given as a guide for a sample of approximately 10g.

Assumed sodium content of sample (%Na)	Dilution factor	Volume of aliquot taken (ml)
Up to 0.1	—	50
0.1 to 0.5	—	10
0.5 to 1.0	—	5
1.0 to 5.0	1:10	10
5.0 to 10.0	1:10	5
10.0 to 20.0	1:20	5

Measure the sodium emission in the flame photometer at a wavelength of 589nm. Determine the concentration of sodium by reference to the calibration curve (5.2).

NOTE: Samples containing more than 4% sodium should be ashed for 2 hours in a crucible provided with a lid. Then allow to cool, add water, bring the ash into suspension by means of a platinum wire and dry. Ash again for 2 hours with the crucible lid in place.

5.2 Calibration curve

Transfer 10.0ml of the standard solution (3.3) into a 250ml graduated flask, dilute to the mark with water and mix. Transfer into a series of 100ml graduated flasks 5, 10, 15, 20 and 25ml of the diluted standard solution. The flasks contain 0.2, 0.4, 0.6, 0.8 and 1.0mg sodium respectively. Complete the series with a blank flask from which only the standard solution has been omitted. To each flask add 10ml of releasing agent (3.2), make up to the mark with water and mix. Carry out the measurements by flame photometry as previously. The calibration curve is generally linear for sodium concentrations up to 1mg per 100ml solution (10 μ g/ml).

6. Expression of the Results

Express the result as a percentage of the sample.

29. UREASE ACTIVITY

1. Scope and Field of Application

This method is for the determination of the urease activity of products derived from soya. It can also be used to determine whether these products have been cooked for a sufficient length of time.

2. Principle

The urease activity is determined by the amount of ammoniacal nitrogen liberated per minute by 1g of the product at 30° C from a solution of urea.

3. Reagents

- 3.1 Hydrochloric acid solution, 0.1N.
- 3.2 Sodium hydroxide solution, 0.1N.
- 3.3 Phosphate buffer solution, 0.05M: dissolve 4.45g disodium hydrogen phosphate ($\text{Na}_2\text{HPO}_4 \cdot 2\text{H}_2\text{O}$) and 3.40g potassium dihydrogen phosphate (KH_2PO_4) in water and dilute to 1,000ml.
- 3.4 Urea releasing agent: dissolve 30.0g urea in 1,000ml phosphate buffer solution (3.3). Prepare immediately before use.

4. Apparatus

- 4.1 Potentiometric titration apparatus or high-sensitivity pH-meter (0.02 pH).
- 4.2 Water bath controlled at 30° C.
- 4.3 Test-tubes, 150 \times 18mm, provided with ground-glass stoppers.

5. Procedure

5.1 Sample preparation

Weigh approximately 10g of the sample and grind so that it passes through a sieve having apertures of 0.2mm.

5.2 Enzymolysis and titration

Weigh to the nearest 0.001g, approximately 0.2g of the prepared sample and transfer to a test-tube provided with a ground-glass stopper (4.3). Add 10ml urea releasing agent (3.4), stopper immediately and shake vigorously. Allow the tube to stand for exactly 30 minutes in a water bath set at 30° C (4.2). Immediately add by pipette 10ml 0.1N hydrochloric acid solution (3.1) and cool rapidly to 20° C. Transfer the contents of the tube quantitatively to a titration vessel, rinsing twice with 5ml of water. Titrate immediately using the potentiometric apparatus (4.1) to pH 4.7, using 0.1N sodium hydroxide solution (3.2).

5.3 Blank test

Weigh to the nearest 0.001g, approximately 0.2g of the prepared sample and transfer to a test-tube provided with a ground-glass stopper (4.3). Add by pipette 10ml 0.1N hydrochloric acid solution (3.1) and 10ml of urea releasing agent (3.4). Immediately cool the tube in ice-water for 30 minutes. Continue as in 5.2 from “. . . Transfer the contents of the tube quantitatively . . .”.

NOTE: For urease activities greater than 1mg of N/g/minute at 30° C, the sample size should be reduced to 50mg. Products containing more than 10% by weight of crude fatty substances should be defatted cold before analysis.

6. Expression of the Results

The urease activity is calculated by using the formula:

$$\text{mg N/g/minute at } 30^{\circ} \text{ C} = \frac{1.4 (b-a)}{30 \times E}$$

where:

a = ml 0.1N sodium hydroxide solution used in the titration of the sample;

b = ml 0.1N sodium hydroxide solution used in the titration of the blank test; and

E = weight of sample in grams.

30a. STARCH—POLARIMETRIC METHOD

1. Scope and Field of Application

This method is for the determination of starch and high molecular weight degradation products of starch in feeding stuffs. It is not applicable to feeding stuffs containing beet chips, beet pulp, dried beet tops or leaves, potato pulp, dried yeasts, products rich in inulin (e.g. dried or powdered Jerusalem artichokes) and products containing greaves.

2. Principle

This method consists of two separate determinations. In the first, the sample is treated with warm diluted hydrochloric acid, clarified and filtered; the optical rotation of the resulting solution is determined. In the second determination, the sample is extracted with 40% ethanol and filtered. The filtrate is acidified with hydrochloric acid, clarified and filtered again; the optical rotation of the resulting solution is determined.

3. Reagents

- 3.1 Hydrochloric acid solution: dilute 700ml hydrochloric acid ($d=1.18\text{g/ml}$) with water to 1,000ml.
- 3.2 Hydrochloric acid solution, 0.309N (1.128% (W/V)): the concentration of this solution must be checked by titration using 0.1N sodium hydroxide solution, with methyl red indicator (0.1g in 100ml 94% (V/V) ethanol).
- 3.3 Carrez solution I: dissolve 21.9g zinc acetate dihydrate in water, add 3ml glacial acetic acid and dilute to 100ml with water.
- 3.4 Carrez solution II: dissolve 10.6g potassium ferrocyanide in water and dilute to 100ml.
- 3.5 Ethanol, 40% (V/V).

4. Apparatus

- 4.1 Erlenmeyer flask, 250ml, provided with ground-glass joint and reflux condenser.
- 4.2 Polarimeter or saccharimeter.

5. Procedure

5.1 Sample preparation

Grind the sample to pass through a sieve having apertures of 0.5mm.

5.2 Determination of total optical rotation

Weigh to the nearest 0.001g, approximately 2.5g of the prepared sample and transfer to a 100ml graduated flask. Add 25ml hydrochloric acid (3.2), stopper and shake until the sample is uniformly suspended, then add a further 25ml of hydrochloric acid (3.2). Immerse the flask in a boiling water bath and shake vigorously for the first 3 minutes to avoid agglomeration of the sample. The quantity of water in the water bath should be sufficient to allow the bath to be maintained at boiling-point on the immersion of the flask. Do not remove the flask from the bath during the shaking process. Keep the flask in the bath for exactly 15 minutes, then remove, add 30ml cold water and cool immediately to a temperature of 20° C. Add 5ml Carrez solution I (3.3) and shake for 1 minute then add 5ml Carrez solution II (3.4) and shake again for 1 minute. Dilute to volume with water, mix and filter. If the filtrate is not perfectly clear, the determination should be abandoned and the analysis repeated using a larger quantity of Carrez solutions I and II (e.g. 10ml). Transfer the solution to a 200mm tube and measure the optical rotation with a polarimeter or saccharimeter.

5.3 Determination of the optical rotation of substances soluble in 40% ethanol (V/V)

Weigh to the nearest 0.001g, approximately 5g of the prepared sample and transfer to a 100ml graduated flask. Add about 80ml ethanol (3.5) (see observation 7.2) and allow to stand for 1 hour, shaking the flask vigorously 6 times during this period in order to disperse the sample. Dilute to volume with ethanol (3.5), mix and filter. Transfer by pipette 50ml of the sample filtrate to a 250ml Erlenmeyer flask, add 2.1ml hydrochloric acid (3.1) and shake vigorously. Fit a reflux condenser to the flask and place the latter on a boiling water bath. Remove the flask from the bath after exactly 15 minutes and transfer the contents to a 100ml graduated flask, rinsing with a little cold water. Cool to a temperature of 20° C. Clarify the solution using Carrez solution I (3.3) and Carrez solution II (3.4) as previously, dilute to volume with water, mix and filter. Measure the optical rotation as in the previous determination (5.2).

6. Expression of the Results

Calculate the percentage of starch in the sample using the following formulae, according to the method of measurement used:

6.1 Measurement by polarimeter

$$\text{Starch (\%)} = \frac{2,000 (P - P^1)}{[a]_D^{20}}$$

where:

P = total optical rotation in degrees;

P¹ = optical rotation in degrees given by substances soluble in ethanol 40% (V/V); and

[a]_D²⁰ = specific rotation of pure starch.

NOTE: The generally accepted values for the specific rotation of starches are given as follows:

Barley starch	+181.5°
Maize starch	+184.6°
Oat starch	+181.3°
Potato starch	+185.7°
Rice starch	+185.9°
Wheat starch	+182.7°
Other starches	+184.0°

(including starch mixtures in compound feeding stuffs).

6.2 *Measurement by saccharimeter*

$$\text{Starch (\%)} = \frac{2,000}{[\alpha]_D^{20}} \times \frac{(2N \times 0.665) (S - S_1)}{100}$$

$$= \frac{26.6N (S - S_1)}{[\alpha]_D^{20}}$$

where:

S = total optical rotation in saccharimetric degrees;

S₁ = optical rotation in saccharimetric degrees given by substances soluble in ethanol 40% (V/V); and

N = weight of sucrose in g per 100ml water which gives a rotation of 100 saccharimetric degrees in a 200mm tube.

= 16.29g for French saccharimeters

= 26.00g for German saccharimeters

= 20.00g for other saccharimeters; and

$[\alpha]_D^{20}$ = specific rotation of pure starch (6.1).

6.3 *Repeatability*

The difference between two separate determinations carried out on the same sample should not exceed 0.4% in absolute value for starch contents less than 40% and 1% in relative value for starch contents equal to, or greater than 40%.

7. Observations

7.1 For samples containing more than 6% by weight of carbonates, calculated as calcium carbonate, the carbonates must be destroyed before the determination by treatment with an equivalent amount of sulphuric acid.

7.2 For samples containing a high lactose content, such as powdered lactoserum or skimmed milk powder, proceed as follows after the addition of 80ml ethanol (3.5):

Fit a reflux condenser to the flask and immerse the flask for 30 minutes in a water bath maintained at 50° C. Allow to cool and continue the analysis as in 5.3 from "... Dilute to volume with ethanol (3.5). mix and filter. Transfer by pipette ...".

30b. STARCH—PANCREATIC METHOD

1. Scope and Field of Application

This method is for the determination of starch and starch degradation products of high molecular weight in feeding stuffs containing beet cossettes, beet pulp, dried beet tops or leaves, potato pulp, dried yeasts, products rich in inulin (e.g. chips and meal of Jerusalem artichokes) and products containing greaves. The determination should only be carried out when microscopic examination indicates that significant quantities of starch are present in the sample.

2. Principle

The sugars are extracted from the sample with ethanol and the starch in the extracted residue is reduced to sugar with pancreatin. The resulting sugars are then hydrolysed with hydrochloric acid and the glucose formed determined by the Luff-Schoorl method. The starch content is calculated by multiplying the glucose content by a constant factor.

3. Reagents

3.1 Pentan-1-ol.

3.2 Toluene.

- 3.3 Ethanol (90% V/V) neutral to phenolphthalein.
- 3.4 Pancreatin, in powder form (see 9.). Keep in stoppered flasks, protected from light and moisture.
- 3.5 Pumice stone, granulated, washed in hydrochloric acid and ignited.
- 3.6 Carrez solution I: dissolve 21.9g of zinc acetate dihydrate in water, add 3ml of glacial acetic acid and dilute to 100ml with water.
- 3.7 Carrez solution II: dissolve 10.6g potassium ferrocyanide in water and dilute to 100ml.
- 3.8 Luff-Schoorl reagent:
 - 3.8.1 Copper sulphate solution: dissolve 25g copper sulphate pentahydrate in water and dilute to 100ml.
 - 3.8.2 Citric acid solution: dissolve 50g citric acid monohydrate in water and dilute to 50ml.
 - 3.8.3 Sodium carbonate solution: dissolve 143.8g anhydrous sodium carbonate in approximately 300ml warm water. Leave to cool. Stirring carefully, pour the citric acid solution (3.8.2) into the sodium carbonate solution (3.8.3). Add the copper sulphate solution (3.8.1) and dilute to 1,000ml with water. Leave to stand overnight and filter. Check the normality of the reagent thus obtained (Cu 0.1N; Na₂ CO₃ 2N). The solution's pH should be approximately 9.4.
- 3.9 Buffer solution: dissolve 9.078g potassium dihydrogen phosphate and 11.876g disodium hydrogen phosphate in water and dilute to 1,000ml.
- 3.10 Potassium iodide solution: 30g potassium iodide per 100ml.
- 3.11 Hydrochloric acid solution, approximately 8N.
- 3.12 Sulphuric acid solution, approximately 6N.
- 3.13 Sodium hydroxide solution, approximately 10N.
- 3.14 Sodium chloride solution, 0.2N.
- 3.15 Hydrochloric acid solution, N.
- 3.16 Sodium thiosulphate solution, 0.1N.
- 3.17 Methyl orange indicator solution: dissolve 0.1g methyl orange in 100ml of ethanol (95–96% V/V).
- 3.18 Starch solution: mix 5g soluble starch with 30ml water and add to 1,000ml boiling water. Boil for 3 minutes and leave to cool. Prepare immediately before use.

4. Apparatus

- 4.1 Extractor (fig. 1) consisting of the following parts:
 - A Wide-necked conical flask, capacity 500ml.
 - B Reflux condenser fitted with a bung to the conical flask.
 - C Sliding spindle fitted with a hook at its lower end and a peg to hold the spindle in place when in the centre of the reflux condenser.
 - D Metal container suspended from the spindle hook (C) and holding the filtration crucible (E).
 - E Filtration crucible, capable of rapid filtration: maximum pore size 90 to 150 microns (porosity 1). Capacity approximately 30ml.
- 4.2 Filter papers to fit the filtration crucible (E).
- 4.3 Incubator, controlled at 38° C.
- 4.4 Graduated flasks, capacity 200ml, provided with ground-glass joints and reflux condensers.
- 4.5 Graduated flasks, capacity 100ml, provided with ground-glass joints and reflux condensers.

5. Procedure

5.1 *Preparation of sample*

Grind the sample so that it passes through a sieve having apertures of 0.5 mm.

5.2 *Extraction*

Weigh to the nearest 0.001g, approximately 2g of the prepared sample and transfer to the filtration crucible (E) containing a filter paper (4.2) previously moistened with ethanol (3.3). Into the conical flask (A) place 55ml ethanol (3.3) and a few grains of pumice stone (3.5). Place the filtration crucible in the metal container (D) and suspend the latter on the spindle hook (C). Pass the spindle through the reflux condenser (B) and fit the latter to the conical flask. Lower the spindle so that the bottom of the crucible just touches the surface of the ethanol and then clamp in position by means of the peg. Bring the ethanol to boiling point and boil for 3 hours, then leave to cool. Raise the crucible as high as possible by means of the spindle and then carefully unstopper the conical flask. Rinse the sides of the conical flask with 45ml water and replace the reflux condenser, adjusting the position of the bottom of the crucible to 100mm above the surface of the liquid. Bring the liquid to boiling point and boil for a further 3 hours, then leave to cool. Unstopper the flask and withdraw the crucible from the container.

5.3 *Saccharification and hydrolysis*

Place the crucible on a vacuum flask and dry under suction. Transfer the extracted residue to a mortar and grind to a fine powder. Transfer the powder quantitatively, using approximately 60ml water, to a 200ml graduated flask provided with a standard ground-glass joint and add a few drops of pentan-1-ol (3.1). Connect a reflux condenser to the flask, boil the contents for 1 hour and then leave to cool. Disconnect the reflux condenser and add 25ml buffer solution (3.9), 0.250g pancreatin (3.4), 2.5ml sodium chloride solution (3.14) and 10 drops toluene (3.2). Shake for 2 minutes and then place the flask in an incubator (4.3) for 21 hours, shaking occasionally. Remove the flask and leave to cool to room temperature.

Add 5ml Carrez solution I (3.6), shake for 1 minute, then add 5ml Carrez solution II (3.7) and shake again for 1 minute. Dilute to volume with water, mix and filter. Transfer by pipette 50ml of filtrate into a 100ml graduated flask (4.5). Add a few drops of indicator solution (3.17) and acidify with 8N hydrochloric acid (3.11). Then add a further 6.25ml 8N hydrochloric acid (3.11) (100ml of filtrate in a 200ml graduated flask may also be used, doubling the quantities of all reagents used). Connect the reflux condenser to the flask, bring the solution to boiling point, and boil for 1 hour. Allow to cool, and then neutralise by adding 10N sodium hydroxide solution (3.13) until the indicator turns yellow. Acidify slightly by adding a little N hydrochloric acid (3.15), make up to volume with water and mix.

Determine the glucose content according to the Luff-Schoorl method described in 5.4.

5.4 *Titration by the Luff-Schoorl method*

Transfer by pipette 25ml Luff-Schoorl reagent into a 300ml conical flask and add 25.0ml of the solution (or a suitable volume diluted to 25.0ml) from 5.3 containing not more than 60mg glucose. Add two granules of pumice stone (3.5) and heat, while swirling by hand, over a free flame of medium height so as to bring the liquid to the boil in approximately two minutes. Place the flask immediately on an asbestos-coated wire gauze with a hole approximately 60mm in diameter, under which a flame has been lit. The flame shall be regulated in such a way that only the base of the flask is heated. Fit a reflux condenser to the flask and boil for exactly 10 minutes. Cool immediately in cold water and titrate after approximately 5 minutes as below:

add 10ml potassium iodide solution (3.10) and, immediately afterwards (add carefully in small increments to prevent excessive foaming), 25ml 6N sulphuric acid (3.12). Titrate with 0.1N sodium thiosulphate (3.16) until a dull yellow colour appears, add a few drops of starch indicator (3.18) and complete the titration.

5.5 *Blank titration*

To a flask containing 10ml potassium iodide solution (3.10) and 25ml 6N sulphuric acid (3.12), transfer 25.0ml Luff-Schoorl reagent (3.8) and 25ml water. Titrate this solution as directed in 5.4. There is no need to boil the solution before titration.

5.6 *Reagent blank*

Carry out a blank test using the procedure described in 5.3 and 5.4, but omitting the sample.

6. Expression of the Results

Calculate the difference between the sample titration (5.4) and the blank titration (5.5), expressed in ml 0.1N sodium thiosulphate solution and from the table determine the amount of glucose in the sample solution. Likewise determine the glucose content of the reagent blank (5.6).

The starch content, as a percentage of the sample, is given by the formula:

$$0.72 (a-b)$$

where:

a=mg of glucose in sample solution; and

b=mg of glucose in blank solution.

NOTE: The quantity of glucose found in the blank test is normally 0.25mg and should not be greater than 0.50mg.

7. Table of Values for 25ml of Luff-Schoorl Reagent

The table gives the amount of glucose expressed in mg that is equivalent to the difference between the sample titre (5.4) and the blank titre (5.5) expressed in ml 0.1N sodium thiosulphate solution.

Sodium thiosulphate, 0.1N ml	Glucose mg
1	2.4
2	4.8
3	7.2
4	9.7
5	12.2
6	14.7
7	17.2
8	19.8
9	22.4
10	25.0
11	27.6
12	30.3
13	33.0
14	35.7
15	38.5
16	41.3
17	44.2
18	47.1
19	50.0
20	53.0
21	56.0
22	59.1
23	62.2

8. Observation

Where partially or totally dextrinated starch and lactose are both present in the sample, the result may be high by 0.5 to 3.0%. In such cases, the actual starch content is obtained as follows:

- (a) determine the reducing sugar content in the ethanolic extract obtained in 5.2 and express the result as a percentage of glucose;
- (b) determine the content of water-soluble reducing sugars in the sample, and express the result as a percentage of glucose;
- (c) deduct the result obtained in (a) from that obtained in (b) and multiply the difference by 0.9; and
- (d) deduct the value obtained in (c) from the starch content obtained by applying the method and calculating as in 6.

9. Directions Relating to Pancreatin

Physical appearance: yellowish-white amorphous powder.

Glucose content: the glucose content of the blank test is normally 0.25mg.

The pancreatin should not be used if this result exceeds 0.50mg.

Check for iodine consumption: suspend 62.5mg pancreatin in approximately 50ml water heated to 25 to 30° C. Add 1ml 0.1N iodine solution and stir for 2 minutes. Titrate with 0.1N sodium thiosulphate solution in the presence of starch indicator. The consumption of iodine solution by pancreatin should not exceed 0.5ml.

Check for amyolytic activity: mix 100ml starch solution (3.18), 5ml buffer solution (3.9), 0.5ml 0.2N sodium chloride solution (3.14) and 62.5mg pancreatin. Heat the mixture to between 25 and 30° C and stir for 2 minutes. Add 1ml 0.1N iodine solution. The blue colouration should disappear within exactly 15 minutes of the addition of the iodine solution.

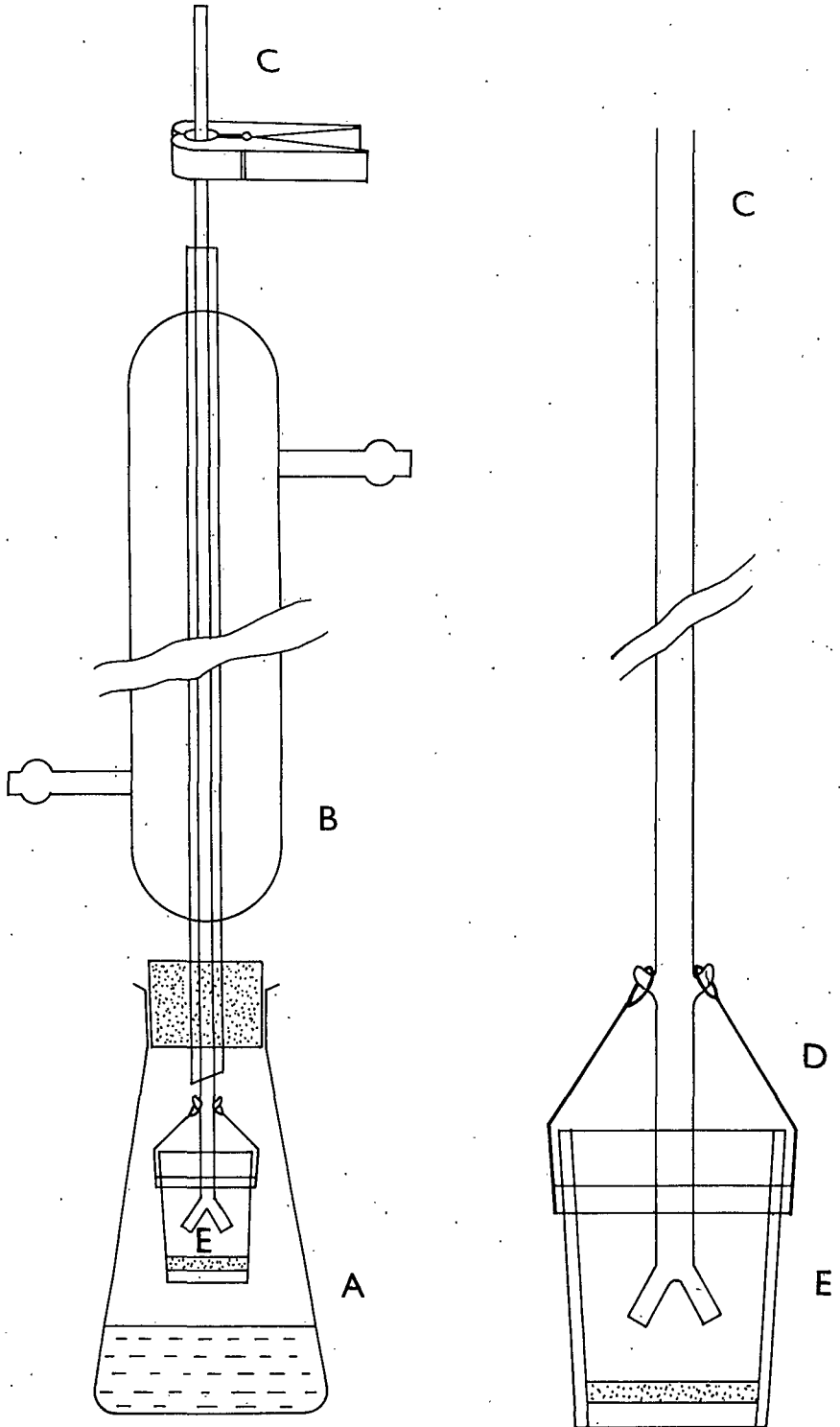

Fig. 1

31. PROTEINS SOLUBLE IN PEPSIN AND HYDROCHLORIC ACID

1. Scope and Field of Application

This method is for the determination of crude proteins soluble in pepsin and hydrochloric acid in feeding stuffs.

2. Principle

The sample is heated in a solution of pepsin hydrochloride for 48 hours at 40° C. The material in suspension is filtered and the nitrogen content of the filtrate determined by the method for crude protein (Method 4).

3. Reagents

- 3.1 Anti-foam (e.g. silicone).
- 3.2 Hydrochloric acid solution, 70% (V/V): dilute 70ml hydrochloric acid ($d=1.18\text{g/ml}$) to 100ml with water.
- 3.3 Pepsin, 2.0 U per mg: this activity is defined and must be controlled according to the method for the determination of pepsin activity: (Method 32).
- 3.4 Pepsin hydrochloride solution: activity 400 U per 1,000ml: dissolve approximately 0.2g pepsin in 1,000ml of 0.075N hydrochloric acid (3.5).
- 3.5 Hydrochloric acid solution, 0.075N.
- 3.6 All reagents listed under 3. of the method for the determination of protein (Method 4).

4. Apparatus

- 4.1 Water bath or incubator controlled at $40\pm 1^\circ\text{C}$.
- 4.2 Apparatus for mineral acid digestion and distillation according to Kjeldahl's method.

5. Procedure

5.1 Preparation of solution

Weigh to the nearest 0.001g, approximately 2g of the prepared sample and transfer to a 500ml graduated flask. Add 450ml pepsin hydrochloride solution (3.4) previously heated to 40° C, and shake the flask to prevent agglomeration of the sample. Check that the pH of the suspension is lower than 1.7. Place the flask in the water bath or incubator (4.1) for 48 hours, shaking after 8, 24 and 32 hours. After 48 hours, add 15ml hydrochloric acid (3.2) and cool to a temperature of 20° C. Dilute to volume with water and filter.

NOTE: samples which contain more than 10% of crude oil should be first defatted by extraction with light petroleum (boiling range 40–60° C).

5.2 Mineral acid digestion

Transfer 250ml of the filtrate to a Kjeldahl flask. Add the reagents necessary for the mineral acid digestion as listed in the method for the determination of protein. (Method 4, 5.1, second sentence). Mix the contents of the flask and boil. Should foaming occur, add several drops of anti-foam (3.1). Boil the contents of the flask vigorously until the water has almost completely evaporated. Eliminate the last traces of water carefully and reduce the rate of heating. When the solution appears clear and colourless, continue boiling for a further hour, then allow to cool.

5.3 Distillation and titration

Proceed as indicated in the method for the determination of protein (Method 4, 5.2 and 5.3).

5.4 Blank test

Carry out a blank test on the reagents, omitting only the sample and following the same procedure.

6. Expression of the Results

Subtract the volume of sulphuric acid consumed by the blank test from the volume of sulphuric acid consumed by the sample. 1ml 0.1N sulphuric acid \equiv 1.4mg nitrogen.

Calculate the percentage of nitrogen in the sample and convert to percentage protein by multiplying the result by 6.25.

7. Observations

- 7.1 The values obtained by this method have no direct connection with digestibility *in vivo*.
- 7.2 The difference between two separate determinations carried out on the same sample should not exceed:
 - 0.4 in absolute value for levels lower than 20%;
 - 2.0% in relative value for levels between 20 and 40%; and
 - 0.8 in absolute value for levels higher than 40%.

32. PEPSIN ACTIVITY

1. Scope and Field of Application

This method is for the determination of the activity of pepsin used in the determination of crude proteins soluble in pepsin and hydrochloric acid in feeding stuffs (Method 31).

2. Principle

Haemoglobin is treated with pepsin in a hydrochloric acid medium under controlled conditions. The non-hydrolysed protein is precipitated by trichloroacetic acid solution and filtered. Sodium hydroxide solution and Folin-Ciocalteu's reagent are added to the filtrate and the absorbance of the solution measured at 750nm. The corresponding quantity of tyrosine is then read from a calibration curve.

NOTE: the unit of pepsin activity is defined as being that quantity of the enzyme which liberates per minute, under the prescribed conditions, a quantity of hydroxyaryl groups whose coloration by Folin-Ciocalteu's reagent has an absorbance corresponding to that given by 1 μ mole of tyrosine under the same conditions.

3. Reagents

- 3.1 Trichloroacetic acid solution: 5g trichloroacetic acid per 100ml.
- 3.2 Sodium hydroxide solution, 0.5N.
- 3.3 Hydrochloric acid solution, 0.025N.
- 3.4 Hydrochloric acid solution, 0.06N.
- 3.5 Hydrochloric acid solution, 0.2N.
- 3.6 Folin-Ciocalteu's reagent: dissolve 100g sodium tungstate dihydrate and 25g sodium molybdate dihydrate in 700ml water contained in a 2,000ml round-bottomed flask fitted with a reflux condenser. Add 50ml phosphoric acid ($d=1.75g/ml$) and 100ml hydrochloric acid ($d=1.18g/ml$) and boil gently under reflux for 10 hours. Cool, remove the reflux condenser and add 175g lithium sulphate dihydrate, 50ml water and 1ml bromine. Boil for 15 minutes to eliminate the excess bromine. Cool and transfer the solution to a 1,000ml graduated flask, dilute to volume with water, mix and filter. The resulting solution should be free of any green colour. Dilute one volume of this reagent with two volumes of water before use.

- 3.7 Haemoglobin solution: determine the nitrogen content of the haemoglobin by Kjeldahl's method (Method 4) and weigh to the nearest 0.001g a quantity corresponding to 354mg nitrogen. Transfer to a 200ml graduated flask provided with a ground-glass joint, add a few ml 0.06N hydrochloric acid (3.4) and connect to a vacuum pump. Apply the vacuum and shake the flask until the haemoglobin has completely dissolved. Release the vacuum and, whilst shaking the flask continuously, dilute to volume with 0.06N hydrochloric acid solution (3.4). Prepare the solution immediately before use.
- 3.8 Standard solution of tyrosine: dissolve 181.2mg of tyrosine in 0.2N hydrochloric acid solution (3.5) and dilute to 1,000ml with the same acid. Transfer by pipette 20ml of this solution to a 100ml graduated flask and make up to the mark with 0.2N hydrochloric acid (3.5). 1 ml of this solution contains 0.2 μ mole tyrosine.

4. Apparatus

- 4.1 Water bath capable of being maintained at $25 \pm 1^\circ\text{C}$.
- 4.2 Spectrophotometer with 10mm cells.
- 4.3 Precision chronometer, accurate to 1 second.
- 4.4 pH meter.

5. Procedure

5.1 Preparation of pepsin solution

Dissolve 150mg pepsin in 100ml 0.06N hydrochloric acid (3.4) and transfer by pipette 2ml of this solution into a 50ml graduated flask. Dilute to volume with 0.025N hydrochloric acid (3.3). Using the pH meter (4.4), check that the pH is 1.6 ± 0.1 , then immerse the flask in the water bath maintained at 25°C (4.1).

5.2 Hydrolysis

Transfer by pipette 5ml haemoglobin solution (3.7) to a test tube and heat to a temperature of 25°C in the water bath (4.1). Add 1.0ml pepsin solution (5.1) and mix thoroughly. Keep the test tube in the water bath for exactly 10 minutes, timed from the addition of the pepsin solution. (Both the timing and the water bath temperature are critical and must be carefully observed). Add 10.0ml trichloroacetic acid solution (3.1) previously heated to 25°C , and mix and filter through a dry filter.

5.3 Colour development and measurement of absorbance

Transfer by pipette 5ml of the filtrate (5.2) to a 50ml Erlenmeyer flask, add 10ml 0.5N sodium hydroxide solution (3.2) and, shaking the flask continuously, 3.0ml of diluted Folin-Ciocalteu's reagent (3.6). Measure the absorbance of the solution at 750nm in the spectrophotometer (4.2) after 5 to 10 minutes, using water as a reference.

5.4 Blank test

For each determination prepare a blank as follows:

Transfer by pipette 5ml of the solution, obtained in 3.7 into a test tube, heat to 25°C in a water bath (4.1) and add 10.0ml trichloroacetic acid solution (3.1) previously heated to 25°C , mix and then add 1.0ml of pepsin solution (5.1). Mix thoroughly and place the flask in a water bath maintained at 25°C for exactly 10 minutes. Mix again and filter through a dry filter. Continue as in 5.3 from Transfer by pipette 5ml of the filtrate

5.5 Calibration curve

Transfer into a series of 50ml Erlenmeyer flasks 1.0, 2.0, 3.0, 4.0 and 5.0ml aliquot parts of standard tyrosine solution (3.8). The flasks contain 0.2, 0.4, 0.6, 0.8 and 1.0 μ moles tyrosine respectively. Complete the series with a flask containing no tyrosine as blank. Make up the volume in each flask to 5.0ml with 0.2N hydrochloric acid (3.5). Add 10.0ml 0.5N sodium hydroxide solution (3.2), and shaking continuously, add 3.0ml of diluted Folin-Ciocalteu's reagent (3.6). Measure the absorbances of the solutions as described in the last sentence of 5.3. Construct a graph relating absorbances to the amounts of tyrosine present.

6. Expression of the Results

By reference to the calibration curve obtained in 5.5, determine the quantity of tyrosine, in μ moles, corresponding to the absorbance of the sample solution and corrected for the blank test.

The pepsin activity, in μ moles of tyrosine per mg per minute at 25°C is given by the formula:

$$\text{Units per mg (U/mg)} = \frac{0.32a}{p}$$

where:

a=quantity of tyrosine in μ moles, determined in the sample solution; and

p=weight of pepsin (in milligrams) added in 5.2.

NOTE 1: The quantity of pepsin taken for the preparation of the pepsin solution in 5.1 must be adjusted in order to obtain an absorbance of 0.35 ± 0.035 after 5 to 10 minutes.

2 units per mg obtained by this method correspond to:

3.64 milliunits Anson/mg (μ mole of tyrosine/mg/min at 35.5°C) or

36,400 commercial units/g (μ moles of tyrosine/g in 10 minutes at 35.5°C).

NOTE 2: For further information on the preparation of haemoglobin see Anson M. L., *J. Gen. Physiol.*, 1938, **22**, 79.

33. MOISTURE IN FATS AND OILS

1. Scope and Field of Application

This method is for the determination of water and volatile substances in animal and vegetable fats and oils.

2. Principle

The sample is dried to constant weight in an oven at 103°C. The loss in weight corresponds to the moisture content of the sample.

3. Apparatus

- 3.1 Corrosion-resistant flat-bottomed dish (diameter: 80 to 90mm; height approximately 30mm).
- 3.2 Mercury thermometer with strengthened bulb and an expansion tube at the top end, graduated from approximately 80°C to at least 110°C, and length approximately 100mm.
- 3.3 Sand bath or electric hot-plate.

4. Procedure

Weigh to the nearest 0.001g, approximately 20g of the prepared sample and transfer to a previously weighed dish (3.1). Stirring the sample continuously with the thermometer (3.2), heat the dish on a sand bath or hot-plate (3.3) so that the temperature reaches 90°C in about 7 minutes. Reduce the heat and observe the frequency with which bubbles rise from the bottom of the dish. The temperature should not exceed 105°C. Continue to stir and scrape the bottom of the dish until the formation of bubbles ceases. In order to ensure the complete elimination of moisture, reheat the dish several times to $103 \pm 2^\circ\text{C}$ and cool to 93°C between successive heatings. Then leave to cool in a desiccator at room temperature and weigh. Repeat this operation until the loss in weight between two successive weighings does not exceed 0.002g.

NOTE: An increase in the weight after repeated heating indicates that oxidation of the fat has taken place. Should this be the case, then calculate the result using the weighing carried out immediately before the weight began to increase.

5. Expression of the Results

Calculate the total loss of weight and express it as a percentage of the sample weight. Results lower than 0.05% should be recorded as 'lower than 0.05%'.

Repeatability:

The difference in moisture between the results of two parallel determinations carried out on the same sample should not exceed 0.05% in absolute value.

34. ISOBUTYLIDENEDIUREA

1. Scope and Field of Application

This method is for the determination of isobutylidenediurea in feeding stuffs.

2. Principle

The sample is hydrolysed, liberating isobutyraldehyde, the concentration of which is determined by gas chromatography.

3. Reagents

- 3.1 Toluene.
- 3.2 Sodium sulphate, anhydrous.
- 3.3 Buffer solution pH1: dissolve 27.2g sodium acetate trihydrate in 300ml 1M hydrochloric acid and add 700ml water.
- 3.4 Buffer solution pH 0.65: dissolve 27.2g sodium acetate trihydrate in 400ml 1M hydrochloric acid and add 600ml water.
- 3.5 Isobutylidenediurea.
- 3.6 Internal standard solution: dilute 5ml isopropyl acetate to 100ml with toluene (3.1).

4. Apparatus

- 4.1 250ml conical flasks with ground glass or PTFE stoppers.
- 4.2 Stoppered centrifuge tubes.
- 4.3 Gas chromatograph with flame ionisation detector.
- 4.4 Column:
 - either (i) 1.5m glass column (4mm internal diameter) packed with 5% OV17 on Gas Chrom Q, 80-100 mesh,
 - or (ii) 1.5m glass column (4mm internal diameter) packed with 5% Carbowax 20M-TPA on Diatomite C-AAW, 80-100 mesh.
- 4.5 Water bath: hotplate stirrer on which is placed a 2,000ml beaker (or suitable vessel) containing water maintained at 40-50°C.

5. Procedure

5.1 Hydrolysis

Weigh to the nearest 0.001g, between 3 and 7g of the prepared sample containing about 0.2g of isobutylidenediurea into a conical flask (4.1). Add 100ml buffer solution (3.4) and 20.0ml toluene (3.1) to the sample and place in the flask a magnetic bar. Stopper firmly to ensure that the flask remains tightly closed during the hydrolysis.

Place the flask in the water bath (4.5) and stir vigorously for 20 minutes. Remove the flask and immerse in an ice-water bath for 5 minutes. Add 15g sodium sulphate (3.2) and 5.0ml internal standard solution (3.6) to the contents of the flask. Stopper the flask again, shake, return to the water bath (4.5) and warm for 3 minutes with stirring. Cool in the ice-water bath for 5 minutes. Transfer slowly between 15 and 25ml of the mixture to the centrifuge tube (4.2), stopper, and centrifuge for 5 minutes to separate the layers. (Repeat the transfer if insufficient toluene is decanted). Transfer a portion of the upper (toluene) layer to a test tube with a pasteur pipette.

5.2 Determination

Inject between 0.5 and 1.0 μ l of the toluene solution (5.1) into the gas chromatograph (4.3).

Suggested conditions:

Column	70°C	Nitrogen	40ml per minute
Injection	150°C	Hydrogen	30ml per minute
Detector	150°C	Air	370ml per minute

Approximate retention times:

Isobutyraldehyde	1min.
Internal standard	1.5min.
Toluene	3min.

Measure the peak heights of the isobutyraldehyde and internal standard. Calculate the peak height ratio, isobutyraldehyde/internal standard, and from this value determine the quantity of isobutylidenediurea present by reference to the calibration curve (5.3).

5.3 Calibration curve

Weigh to the nearest mg, 100, 200 and 300mg isobutylidenediurea (3.5) into three conical flasks (4.1). Add 100ml buffer solution (3.3), 20.0ml toluene (3.1) and a magnetic bar to each. Stopper the flasks firmly. Continue as in 5.1 from "... Place the flask in the water bath ...". Inject the toluene solutions into the gas chromatograph (4.3), and measure the peak heights. Calculate the respective peak height ratios, isobutyraldehyde/internal standard, and plot the calibration curve using peak height ratios as the ordinates and the corresponding weights of isobutylidenediurea as the abscissae.

6. Expression of the Results

The per cent content of isobutylidenediurea in the sample is given by the formula:

$$\frac{A}{W \times 10}$$

where:

A = weight of isobutylidenediurea (mg) read from the calibration curve; and

W = weight of sample in grams.

FORM OF CERTIFICATE OF ANALYSIS

PART I

CERTIFICATE OF ANALYSIS OF FEEDING STUFF (1)

I, the undersigned, agricultural analyst for Northern Ireland, in pursuance of the provisions of Part IV of the Agriculture Act 1970, hereby certify that I received on the day of 19 , from (2) one part of a sample of (3) for analysis; which was duly sealed and fastened up and marked (4) and was accompanied by a (5) as follows:—(6)

and also by a signed statement that the sample was taken in the prescribed manner; and that the said part has been analysed by me, or under my direction, and I declare the results of analysis to be as follows:—(7)

(8) Analysis for oil was completed on
(9)
and I am of the opinion that (10)

Where a method is prescribed by the Feeding Stuffs (Sampling and Analysis) Regulations (Northern Ireland) 1982 that method was used in the analysis.

Signature of analyst
Address

Date

PART II

GUIDANCE NOTES

- (1) Statements made in certificates are to be confined to matters which are necessary to verify compliance with the Act.
- (2) Insert the name of the inspector who submitted the sample for analysis; and also the mode of transit, for example "by hand", "by registered post", "by rail", as the case may be.
- (3) Insert the name or description applied to the material.
- (4) Insert the distinguishing mark on the sample and the date of sampling shown thereon.
- (5) Insert either "statutory statement", "copy of statutory statement", "copy of particulars marked on the material" or "copy of particulars indicated by a mark applied to the material", or as the case may be.
- (6) Insert the particulars contained in the statutory statement, or particulars marked on or indicated by a mark applied to the material, or as the case may be.
- (7) Insert relevant results, including if appropriate
 - (a) The name and estimated percentage of any deleterious ingredient or undesirable substance found in the sample.
 - (b) The name or names of any additives found in the sample and whether or not they are permitted.
 - (c) In the cases of those additives for which maxima are prescribed whether the amounts found are in excess of the prescribed maxima.
- (8) In the case of a sample of any feeding stuff containing oil insert the date of completion of the oil analysis.
- (9) In the case of analysis of substances for which no analytical method is prescribed in Schedule 2 indicate the method used. If analysis cannot be carried out because no suitable method exists then the certificate should be noted accordingly.
- (10) Enter information as follows:—
 - (a) whether the material was correctly named in accordance with the requirements of the Feeding Stuffs Regulations (Northern Ireland) 1982 and whether it accords with the meaning corresponding to that name; and if not, in what respect.
 - (b) if the composition of the material agrees with or does not differ by more than the limits of variation from the statement of particulars contained in the statutory statement, or the particulars marked on or indicated by a mark associated with the material, state that the particulars are correct within the limits of variation.
 - (c) if the composition of the material differs by more than the limits of variation from the statement of particulars contained in the statutory statement, or the particulars marked on or indicated by a mark associated with the material, or as the case may be, state the difference between the amount found and the amount stated, and that the difference is outside the limits of variation; and that the difference is to the prejudice of the purchaser, if such is believed to be the case.
 - (d) if the material is not suitable for use as a feeding stuff having regard to section 72 of the Act state in what respect.

EXPLANATORY NOTE

(This note is not part of the Regulations.)

These regulations are made under Part IV of the Agriculture Act 1970 and (together with the Feeding Stuffs Regulations (Northern Ireland) 1982) supersede the Fertilisers and Feeding Stuffs Regulations (Northern Ireland) 1973 so far as feeding stuffs are concerned. They apply throughout Northern Ireland and now affect pet foods.

The regulations modify the Act as respects metrication (regulation 8), and prescribe matters for the purposes of the Act, namely

- (1) the amount of material for the purposes of the definition of sampled portion (regulation 2),
- (2) the manner of taking samples (regulation 3 and Schedule 1),
- (3) the methods of sending samples (regulation 4),
- (4) the methods of analysis (regulation 5 and Schedule 2),
- (5) the form of certificate of analysis (regulation 6 and Schedule 3), and
- (6) the period within which analysis of oil content must be carried out (regulation 8).

The regulations introduce revised methods of analysis and implement in part the following Commission Directives:—

- 71/250/EEC (OJ No. L155, 12.7.71, p. 13) (OJ/S.E. 1971 (II) p. 480),
71/393/EEC (OJ No. L279, 20.12.71, p. 7) (OJ/S.E. 1971 (III) p. 987),
72/199/EEC (OJ No. L123, 29.5.72, p. 6),
73/46/EEC (OJ No. L83, 30.3.73, p. 21),
74/203/EEC (OJ No. L108, 22.4.74, p. 7),
76/372/EEC (OJ No. L102, 15.4.76, p. 8),
78/633/EEC (OJ No. L206, 29.7.78, p. 43), and
81/680/EEC (OJ No. L246, 29.8.81, p. 32),

which establish Community methods of analysis for the official control of feeding stuffs.

They also implement Commission Directive 76/371/EEC (OJ No. L102, 15.4.76, p. 1) as regards sampling.

1982 No. 339

This Order has been exempted from printing by the Statutory Rules (Northern Ireland) Order 1979. A summary is given in the List of Statutory Rules of a Local Character under the heading ROADS.