

COMMISSION REGULATION (EU) No 678/2011

of 14 July 2011

replacing Annex II and amending Annexes IV, IX and XI to Directive 2007/46/EC of the European Parliament and of the Council establishing a framework for the approval of motor vehicles and their trailers, and of systems, components and separate technical units intended for such vehicles (Framework Directive)

(Text with EEA relevance)

THE EUROPEAN COMMISSION,

Having regard to the Treaty on the Functioning of the European Union,

Having regard to Directive 2007/46/EC of the European Parliament and of the Council of 5 September 2007 establishing a framework for the approval of motor vehicles and their trailers, and of systems, components and separate technical units intended for such vehicles (Framework Directive) ⁽¹⁾, and in particular Article 39(2) and (3) thereof,

Whereas:

- (1) Directive 2007/46/EC establishes a harmonised framework containing the administrative provisions and general technical requirements for all new vehicles, systems, components and separate technical units. In particular it includes the specific definitions concerning vehicles that are necessary for the proper functioning of the European type-approval system.
- (2) One of the objectives of Directive 2007/46/EC is to extend the European vehicle type-approval system to all vehicle categories. Annex II to Directive 2007/46/EC that includes the necessary specific definitions has to be redesigned in order to take technical progress into account. It is therefore necessary to amend existing definitions or to establish new definitions.
- (3) Experience shows that the current criteria for determining whether a new model of vehicle is to be considered a new type are too vague. This lack of certainty can delay the implementation of new requirements laid down in EU legislation regarding new vehicle types. Moreover, experience shows that it is possible to circumvent the EU small series legislation by dividing a vehicle type into several sub-types under different type-approvals. Consequently, the number of new vehicles that may be put into service in the European Union under the small series regime can exceed what is permissible. It is therefore important to specify which vehicle technical features are to be used as criteria in determining what constitutes a new type.

(4) In accordance with the principles enshrined in the communications from the Commission entitled Action plan 'Simplifying and improving the regulatory environment' ⁽²⁾ and Action programme for 'Reducing administrative burdens in the European Union' ⁽³⁾, it is appropriate to reconsider the criteria to be used for the definition of the variants and versions within a vehicle type with a view to reducing the administrative burden placed on vehicle manufacturers. This would result, moreover, in making the type-approval process more transparent for the competent authorities of the Member States.

(5) Given the trends for globalisation on the automotive sector, the work of the World Forum for Harmonisation of Vehicle Regulations – 'the Working Party 29 (WP.29)' - is increasingly significant. As it is essential in order to meet the recommendations of the CARS 21 High Level Group to incorporate Regulations of the Economic Commission for Europe of the United Nations (UNECE) into EU law or even to replace EU Directives or Regulations by UNECE Regulations as well as to incorporate global technical Regulations into EU law, the consistency of the legislation of the European Union with the UNECE Regulations should be ensured.

(6) Given the harmonisation work in progress in the World Forum for Harmonisation of Vehicle Regulations, it is essential to take account of the most recent developments laid down in Resolution R.E. 3 on Classification and definition of power-driven vehicles and trailers in the framework of the Agreement of the UNECE concerning the adoption of uniform prescriptions for wheeled vehicles, equipment and parts which can be fitted to and/or used on wheeled vehicles and the conditions for reciprocal recognition of approvals granted on the basis of these prescriptions (Revised 1958 Agreement) as well as the Special Resolution S.R. 1 concerning the common definitions of vehicle categories, masses and dimensions in the framework of the UNECE Agreement concerning the establishing of global technical regulations for wheeled vehicles, equipment and parts which can be fitted and/or be used on wheeled vehicles ('Parallel or 1998 Agreement'). Only the inclusion of those developments in the Framework Directive can ensure the proper functioning of the European type-approval system. It is therefore necessary to introduce new criteria for determining whether a vehicle type should be categorised in an 'M' category or an 'N' category.

⁽¹⁾ OJ L 263, 9.10.2007, p. 1.

⁽²⁾ COM(2002) 278 final.

⁽³⁾ COM(2007) 23 final.

- (7) In accordance with Article 8 of Regulation (EC) No 443/2009 of the European Parliament and of the Council of 23 April 2009 setting emission performance for new passenger cars as part of the Community's integrated approach to reduce CO₂ emissions from light-duty vehicles⁽¹⁾, Member States are required to keep a register containing data relating to inter alia the type, variant and version of each particular vehicle with regard to its specific emissions of CO₂ for each new vehicles registered in its territory. It is essential to specify the criteria in accordance with which a light-duty vehicle has to be type-approved as M₁ or as N₁ vehicle. These criteria should be objective and constitute guidance for vehicle manufacturers as well as for type-approval and registration authorities. In accordance with Article 13 (4) of Regulation (EC) No 443/2009, the presence of innovative technologies fostering further CO₂ emission reduction must be identified. This should be achieved by means of a 'code' assigned to the vehicle by the manufacturer so that each type/variant/version corresponds to a unique set of innovative technologies. Identification of those innovative technologies should thus be possible from the definition of the type-variant-version. It is therefore appropriate to add the corresponding entry into Annex II to Directive 2007/46/EC.
- (8) As the type of bodywork has to be specified in the certificate of conformity, which is intended to facilitate the registration of new vehicles in the Member States, the use of harmonised codes for each kind of bodywork should constitute a simplification in the registration process. A list of appropriate codes should be assigned to the kinds of bodywork in order to allow the data processing to be automated.
- (9) As trailers designed especially for abnormal load transport cannot meet all the provisions of the regulatory acts listed in Annex IV to Directive 2007/46/EC that are required to be complied with for the purpose of European type-approval, it is appropriate to include those trailers in the category of special purposes vehicles given their technical features. For the purposes of type-approval a simplified set of rules should be laid down in order to make their type-approval at European level possible. Consequently it is necessary to add a new Appendix to Annex XI to Directive 2007/46/EC.
- (10) New technical developments are currently in progress in order to cope with the demand for new solutions in the transport of goods. It is therefore necessary to include new definitions in the framework legislation in order to permit subsequently appropriate technical rules to be laid down in the relevant regulatory acts listed in Annex IV or XI to Directive 2007/46/EC. It is important to make clear that no EC type-approval should be granted for such vehicles until the type-approval legislation is amended for such purposes.
- (11) An error occurred in the adoption of Commission Directive 2010/19/EU of 9 March 2010 amending, for the purposes of adaptation to technical progress in the field of spray-suppression systems of certain categories of motor vehicles and their trailers, Council Directive 91/226/EEC, and Directive 2007/46/EC of the European Parliament and of the Council⁽²⁾ in so far as Annexes IV and XI to Directive 2007/46/EC were also amended by that Directive. Those annexes had previously been replaced by Commission Regulation (EC) No 1060/2008 of 7 October 2008 replacing Annexes I, III, IV, VI, VII, XI, and XV to Directive 2007/46/EC of the European Parliament and of the Council establishing a framework for the approval of motor vehicles and their trailers, and of systems, components and separate technical units intended for such vehicles (Framework Directive)⁽³⁾. In the interest of legal certainty, any partial amendment to those annexes should henceforth only be introduced by a Regulation. As the corresponding Article 2 of Directive 2010/19/EU has been deleted by Commission Decision 2011/415/EU of 14 July 2011 correcting Directive 2010/19/EU amending, for the purposes of adaptation to technical progress in the field of spray-suppression systems of certain categories of motor vehicles and their trailers, Council Directive 91/226/EEC, and Directive 2007/46/EC of the European Parliament and of the Council as regards the amendment of the annexes to Directive 2007/46/EC⁽⁴⁾ in order to remedy that error, it is appropriate to effectuate the amendments previously contained in that Article by way of this Regulation.
- (12) It is appropriate with a view to ensuring the proper operation of the type-approval system to update the annexes to Directive 2007/46/EC in order to adapt them to the development of scientific and technical knowledge.
- (13) It is also appropriate to update the annexes to Directive 2007/46/EC in order to lay down technical requirements for special purpose vehicles to be type-approved.
- (14) Since the provisions of those annexes are sufficiently detailed and need no further transposition measures by Member States, it is therefore appropriate to replace Annex II and amend Annexes IV, IX and XI by means of a Regulation in accordance with Article 39 (8) of Directive 2007/46/EC.
- (15) Annex II should be replaced and Annexes IV, IX and XI should be amended accordingly.

(1) OJ L 140, 5.6.2009 p. 1.

(2) OJ L 72, 20.3.2010, p. 17.

(3) OJ L 292, 31.10.2008, p. 1.

(4) See page 76 of this Official Journal.

- (16) The measures provided for in this Regulation are in accordance with the opinion of the Technical Committee – Motor Vehicles,

HAS ADOPTED THIS REGULATION:

Article 1

Directive 2007/46/EC shall be amended as follows:

- (1) Annex II is replaced by the text set out in Annex I to this Regulation;
- (2) Annex IV is amended as set out in Annex II to this Regulation;
- (3) Annex IX is amended as set out in Annex III to this Regulation;
- (4) Annex XI is amended as set out in Annex IV to this Regulation.

Article 2

This Regulation shall not invalidate any vehicle type-approval granted before 29 October 2012 nor prevent extension of such approvals.

Article 3

1. This Regulation shall enter into force on the 20th day following its publication in the *Official Journal of the European Union*.

It shall apply to new vehicle types for which approval will be granted on and after 29 October 2012.

However, the requirements set out in Annex II and in points 1 and 2 of Annex IV shall apply from 9 April 2011.

2. By way of derogation from paragraph 1 second subparagraph manufacturers may as from 4 August 2011 apply any provision of this Regulation.

This Regulation shall be binding in its entirety and directly applicable in all Member States.

Done at Brussels, 14 July 2011.

For the Commission
The President
José Manuel BARROSO

ANNEX I

ANNEX II

GENERAL DEFINITIONS, CRITERIA FOR VEHICLE CATEGORISATION, VEHICLE TYPES AND TYPES OF BODYWORK

INTRODUCTORY PART

General definitions and general provisions**1. Definitions**

1.1. "Seating position" means any location capable of accommodating one person seated who is at least as large as:

- (a) the manikin of the 50th percentile male in the case of the driver;
- (b) the manikin of the 5th percentile adult female in all other cases.

1.2. "Seat" means a complete structure with trim, integral or not with the vehicle body structure, which is intended to seat one person.

1.2.1. The term "seat" covers both an individual seat and a bench seat.

1.2.2. Folding seats and removable seats are included in this definition.

1.3. "Goods" means primarily any movable things.

The term "goods" includes products in bulk, manufactured goods, liquids, living animals, crops, indivisible loads.

1.4. "Maximum mass" means the "technically permissible maximum laden mass" as specified in point 2.8 of Annex I.

2. General provisions

2.1. Number of seating positions

2.1.1. The requirements regarding the number of seating positions apply to seats that are designed for use when the vehicle is travelling on the road.

2.1.2. They do not apply to seats that are designed for use when the vehicle is stationary and which are clearly identified to users either by means of a pictogram or a sign with an appropriate text.

2.1.3. The following requirements apply for the counting of the seating positions:

- (a) each individual seat shall be counted as one seating position;
- (b) in the case of a bench seat, any space having a width of at least 400 mm measured at the seat cushion level shall be counted as one seating position.

This condition shall not prevent the manufacturer from using the general provisions referred to in point 1.1;

(c) however, a space as referred to in point (b) shall not be counted as one seating position where:

- (i) the bench seat includes features that prevent the bottom of the manikin from sitting in a natural way - for example: the presence of a fixed console box, an unpadded area or an interior trim interrupting the nominal seating surface;
- (ii) the design of the floor pan located immediately in front of a presumed seating position (for example the presence of a tunnel) prevents the feet of the manikin from being positioned in a natural way.

2.1.4. With respect to vehicles covered by Directive 2001/85/EC of the European Parliament and of the Council of 20 November 2001 relating to special provisions for vehicles used for the carriage of passengers comprising more than eight seats in addition to the driver's seat, and amending Directives 70/156/EEC and 97/27/EC ⁽¹⁾, the dimension referred to in point 2.1.3(b) shall be aligned with the minimum space required for one person in relation to the various classes of vehicles.

⁽¹⁾ OJ L 42, 13.2.2002, p. 1.

- 2.1.5. When seat anchors for a removable seat are present in a vehicle, the removable seat shall be counted in the determination of the number of the seating positions.
- 2.1.6. An area intended for an occupied wheelchair shall be regarded as one seating position.
- 2.1.6.1. This provision shall be without prejudice to the requirements of point 3.6.1 and point 3.7 of Annex VII to Directive 2001/85/EC.
- 2.2. Maximum mass
- 2.2.1. In the case of a tractor unit for semi-trailer, the maximum mass to be considered for classifying the vehicle shall include the maximum mass of the semi-trailer borne by the fifth wheel coupling.
- 2.2.2. In the case of a motor vehicle that can tow a centre-axle trailer or a rigid drawbar trailer, the maximum mass to be considered for classifying the motor vehicle shall include the maximum mass transferred to the towing vehicle by the coupling.
- 2.2.3. In the case of a semi-trailer, a centre-axle trailer and a rigid drawbar trailer, the maximum mass to be considered for classifying the vehicle shall correspond to the maximum mass transmitted to the ground by the wheels of an axle or group of axles when coupled to the towing vehicle.
- 2.2.4. In the case of a converter dolly, the maximum mass to be considered for classifying the vehicle shall include the maximum mass of the semi-trailer borne by the fifth wheel coupling.
- 2.3. Special equipment
- 2.3.1. Vehicles fitted primarily with fixed equipment such as machinery or apparatus shall be regarded as N or O category.
- 2.4. Units
- 2.4.1. Unless otherwise stated any unit of measurement and associated symbol shall conform to the provisions of Council Directive 80/181/EEC ⁽¹⁾.
3. **Categorisation into vehicle categories**
- 3.1. The manufacturer is responsible for the categorisation of a type of vehicle into a specific category.
- For such purposes, all the relevant criteria described in this Annex shall be met.
- 3.2. The approval authority may request from the manufacturer appropriate additional information with the aim of demonstrating that a vehicle type needs to be categorised as special purpose vehicle in the special group ("SG Code").

PART A

Criteria for vehicle categorisation

1. Vehicle categories

For the purposes of European and national type-approval, as well as individual approval, vehicles shall be categorised according to the following classification:

(It is understood that approval can only be granted for the categories referred to in points 1.1.1 to 1.1.3, 1.2.1 to 1.2.3 and 1.3.1 to 1.3.4.)

- 1.1. Category M Motor vehicles designed and constructed primarily for the carriage of persons and their luggage.
- 1.1.1. Category M₁ Vehicles of category M, comprising not more than eight seating positions in addition to the driver's seating position.

Vehicles belonging to category M₁ shall have no space for standing passengers.

The number of seating positions may be restricted to one (i.e. the driver's seating position).

⁽¹⁾ OJ L 39, 15.2.1980 p. 40.

- 1.1.2. Category M₂ Vehicles of category M, comprising more than eight seating positions in addition to the driver's seating position and having a maximum mass not exceeding 5 tonnes.
- Vehicles belonging to category M₂ may have space for standing passengers in addition to the seating positions.
- 1.1.3. Category M₃ Vehicles of category M, comprising more than eight seating positions in addition to the driver's seating position and having a maximum mass exceeding 5 tonnes.
- Vehicles belonging to category M₃ may have space for standing passengers.
- 1.2. Category N Motor vehicles designed and constructed primarily for the carriage of goods.
- 1.2.1. Category N₁ Vehicles of category N having a maximum mass not exceeding 3,5 tonnes.
- 1.2.2. Category N₂ Vehicles of category N having a maximum mass exceeding 3,5 tonnes but not exceeding 12 tonnes.
- 1.2.3. Category N₃ Vehicles of category N having a maximum mass exceeding 12 tonnes.
- 1.3. Category O Trailers designed and constructed for the carriage of goods or of persons as well as for the accommodation of persons.
- 1.3.1. Category O₁ Vehicles of category O having a maximum mass not exceeding 0,75 tonnes
- 1.3.2. Category O₂ Vehicles of category O having a maximum mass exceeding 0,75 tonnes but not exceeding 3,5 tonnes.
- 1.3.3. Category O₃ Vehicles of category O having a maximum mass exceeding 3,5 tonnes but not exceeding 10 tonnes.
- 1.3.4. Category O₄ Vehicles of category O having a maximum mass exceeding 10 tonnes.

2. Vehicle subcategories

2.1. Off-road vehicles

"Off-road vehicle (ORV)" means a vehicle that belongs either to category M or N, having specific technical features which permit its use off the normal roads.

For those categories of vehicles, the letter "G" shall be added as suffix to the letter and numeral identifying the vehicle category.

The criteria for the subcategorisation of vehicles as "ORV" shall be specified in Section 4 of Part A of this Annex.

2.2. Special purpose vehicles

2.2.1. "Special purpose vehicle (SPV)" means a vehicle of category M, N or O having specific technical features in order to perform a function which requires special arrangements and/or equipment.

For incomplete vehicles that are intended to fall into the SPV subcategory, the letter "S" shall be added as suffix to the letter and numeral identifying the vehicle category.

The various types of special purpose vehicles are defined and listed in Section 5.

2.3. Off road special purpose vehicle

2.3.1. "Off road special purpose vehicle (ORV-SPV)" means a vehicle that belongs either to category M or N having the specific technical features referred to in points 2.1 and 2.2.

For those categories of vehicles, the letter "G" shall be added as suffix to the letter and numeral identifying the vehicle category.

Moreover, for incomplete vehicles that are intended to fall into the SPV subcategory, the letter "S" shall be added as second suffix.

3. **Criteria for the categorisation of vehicles in category N**
- 3.1. The categorisation of a vehicle type in category N shall be based on the technical features of the vehicle as referred to in points 3.2 to 3.6.
- 3.2. As a matter of principle, the compartment(s) where all the seating positions are located shall be completely separated from the loading area.
- 3.3. By way of derogation from the requirements of point 3.2, persons and goods may be transported in the same compartment under the condition that the loading area is provided with securing devices designed to protect persons transported against the displacement of the load during driving, including severe braking and cornering.
- 3.4. Securing devices - lashing devices - intended for securing the load as required in point 3.3 as well as partitioning systems, intended for vehicles up to 7,5 tonnes shall be designed in accordance with the provisions of Sections 3 and 4 of Standard ISO 27956:2009 "Road vehicles – Securing of cargo in delivery vans – Requirements and test methods".
- 3.4.1. The requirements referred to in point 3.4 may be verified by a statement of compliance provided by the manufacturer.
- 3.4.2. As an alternative to the requirements of point 3.4, the manufacturer may demonstrate to the satisfaction of the approval authority that the securing devices fitted show an equivalent level of protection as provided in the referred standard.
- 3.5. The number of seating positions excluding the driver's seating position shall not exceed:
- (a) 6 in the case of N₁ vehicles;
- (b) 8 in the case of N₂ or N₃ vehicles.
- 3.6. Vehicles shall show a goods-carrying capacity equal or higher than the person-carrying capacity expressed in kg.
- 3.6.1. For such purposes, the following equations shall be satisfied in all configurations, in particular when all seating positions are occupied:
- (a) when N = 0:
- $$P - M \geq 100 \text{ kg}$$
- (b) when 0 < N ≤ 2:
- $$P - (M + N \times 68) \geq 150 \text{ kg};$$
- (c) when N > 2:
- $$P - (M + N \times 68) \geq N \times 68;$$
- where the letters have the following meaning:
- "P" is the technically permissible maximum laden mass;
- "M" is the mass in running order;
- "N" is the number of seating positions excluding the driver's seating position.
- 3.6.2. The mass of equipment that is fitted to the vehicle in order to accommodate goods (e.g. tank, bodywork, etc.), to handle goods (e.g. crane, lift, etc.) and to secure goods (e.g. cargo securing devices) shall be included in M.
- The mass of equipment that is not used for the purposes referred to above (such as a compressor, a winch, an electric power generator, broadcasting equipment, etc.) shall not be included in M for the purposes of the application of the above formulae.
- 3.7. The requirements referred to in points 3.2 to 3.6 shall be met for all variants and versions within the vehicle type.
- 3.8. Criteria for the categorisation of vehicles as N₁.

3.8.1. A vehicle shall be categorised as N₁ when all the applicable criteria are met.

When one or more of the criteria are not met, the vehicle shall be categorised as M₁.

3.8.2. In addition to the general criteria referred to in points 3.2 to 3.6, the criteria specified in points 3.8.2.1 to 3.8.2.3.5 shall be met for the categorisation of vehicles for which the compartment where the driver is located and the load are within a single unit (i.e. bodywork "BB").

3.8.2.1. The fact that a wall or a partition, complete or partial, is fitted between a seat row and the cargo area shall not rule out the obligation to meet the required criteria.

3.8.2.2. The criteria shall be as follows:

(a) the loading of the goods shall be possible by a rear door, a tailgate or a side-door designed and constructed for that purposes;

(b) in the case of a rear door or a tailgate, the loading aperture shall meet the following requirements:

(i) in the case the vehicle is fitted with only one row of seats or with only the driver seat, the minimum height of the loading aperture shall be at least 600 mm;

(ii) in the case the vehicle is fitted with two or more rows of seats, the minimum height of the loading aperture shall be at least 800 mm and the aperture shall show a surface of at least 12 800 cm²;

(c) The cargo area shall meet the following requirements:

"cargo area" means the part of the vehicle located behind the row(s) of seats or behind the driver seat when the vehicle is fitted with only one driver seat;

(i) the loading surface of the cargo area shall be generally flat;

(ii) where the vehicle is fitted with only one row of seats or with one seat, the minimum length of the cargo area shall be at least 40 % of the wheelbase;

(iii) where the vehicle is fitted with two or more rows of seats, the minimum length of the cargo area shall be at least 30 % of the wheelbase.

Where the seats of the last row of seats can be easily removed from the vehicle without the use of special tools, the requirements regarding the length of the cargo area shall be met with all the seats installed in the vehicle;

(iv) the requirements regarding the length of the cargo area shall be met when the seats of the first row or of the last row, as the case may be, are upright in their normal position for use by the vehicle occupants.

3.8.2.3. Specific conditions for measurement

3.8.2.3.1. Definitions

(a) "*Height of the loading aperture*", means the vertical distance between two horizontal planes tangent respectively to the highest point of the lower part of the doorway and the lowest point of the upper part of the doorway;

(b) "*surface of the loading aperture*" means the greatest surface of the orthogonal projection on a vertical plane, perpendicular to the centreline of the vehicle, of the maximum aperture permitted when the rear door(s) or tailgate is (are) wide open;

(c) "*wheelbase*", for the purposes of application of the formulae in points 3.8.2.2 and 3.8.3.1, means the distance between:

(i) the centreline of the front axle and the centreline of the second axle in the case of a two axle vehicle;
or

(ii) the centreline of the front axle and the centreline of a virtual axle equally distant from the second and third axle in the case of a three axle vehicle.

3.8.2.3.2. Seat adjustments

- (a) the seats shall be adjusted at their rear outermost positions;
- (b) the seat back, if adjustable, shall be adjusted as to accommodate the three-dimensional H-point machine at a torso angle of 25 degrees;
- (c) the seat back, if not adjustable, shall be in the position designed by the vehicle manufacturer;
- (d) When the seat is adjustable in height, it shall be adjusted to its lowest position.

3.8.2.3.3. Vehicle conditions

- (a) the vehicle shall be in loaded conditions corresponding to its maximum mass;
- (b) the vehicle shall be with its wheels straight ahead.

3.8.2.3.4. The requirements of point 3.8.2.3.2 shall not apply when the vehicle is fitted with a wall or a partition.

3.8.2.3.5. Measurement of the length of the cargo area

- (a) When the vehicle is not fitted with a partition or a wall, the length shall be measured from a vertical plane tangent to the rear outermost point of the top of the seat back to the rear internal pane or door or tailgate, in closed position;
- (b) when the vehicle is fitted with a partition or a wall, the length shall be measured from a vertical plane tangent to the rear outermost point of the partition or the wall to the rear internal pane or door or tailgate, as the case may be, in closed position;
- (c) the requirements concerning the length shall be fulfilled at least along an horizontal line situated in the longitudinal vertical plane passing through the centreline of the vehicle, at the level of the load floor.

3.8.3. In addition to the general criteria referred to in points 3.2 to 3.6, the criteria specified in points 3.8.3.1 to 3.8.3.4 shall be met for the categorisation of vehicles for which the compartment where the driver is located and the load are not within a single unit (i.e. bodywork "BE").

3.8.3.1. Where the vehicle is fitted with an enclosure type body, the following shall apply:

- (a) the loading of the goods shall be possible by a rear door, a tailgate or a panel or other means;
- (b) the minimum height of the loading aperture shall be at least 800 mm and the aperture shall show a surface of at least 12 800 cm²;
- (c) The minimum length of the cargo area shall be at least 40 % of the wheelbase.

3.8.3.2. Where the vehicle is fitted with an open type cargo area, only the provisions referred to in points 3.8.3.1(a) and (c) shall apply.

3.8.3.3. For the application of the provisions referred to in point 3.8.3, the definitions in point 3.8.2 shall apply *mutatis mutandis*.

3.8.3.4. However, the requirements concerning the length of the cargo area shall be fulfilled along a horizontal line situated in the longitudinal plane passing through the centreline of the vehicle at the level of the load floor.

4. Criteria for the subcategorisation of vehicles as off-road vehicles

4.1. M₁ or N₁ vehicles shall be subcategorised as off-road vehicles if they satisfy at the same time the following conditions:

- (a) at least one front and at least one rear axle designed to be driven simultaneously irrespective of whether one powered axle can be disengaged;
- (b) at least one differential locking mechanism or a mechanism having similar effect is fitted;
- (c) they are able to climb at least a 25 % gradient as solo vehicle;
- (d) they satisfy five out of the following six requirements:
 - (i) the approach angle shall be at least 25 degrees;
 - (ii) the departure angle shall be at least 20 degrees;

- (iii) the ramp angle shall be at least 20 degrees;
 - (iv) the ground clearance under the front axle shall be at least 180 mm;
 - (v) the ground clearance under the rear axle shall be at least 180 mm;
 - (vi) the ground clearance between the axles shall be at least 200 mm.
- 4.2. M_2 , N_2 or M_3 vehicles whose maximum mass does not exceed 12 tonnes shall be subcategorised as off-road vehicles if they satisfy the condition set out in point (a) or both conditions set out in points (b) and (c):
- (a) all their axles are driven simultaneously, irrespective of whether one or more powered axles can be disengaged;
 - (b) (i) at least one front and at least one rear axle are designed to be driven simultaneously irrespective of whether one powered axle can be disengaged;
 - (ii) at least one differential locking mechanism or a mechanism having the same effect is fitted;
 - (iii) they are able to climb a 25 % gradient as a solo vehicle;
 - (c) they satisfy at least five out of the following six requirements if their maximum mass does not exceed 7,5 tonnes and at least four if their maximum mass exceeds 7,5 tonnes:
 - (i) the approach angle shall be at least 25 degrees;
 - (ii) the departure angle shall be at least 25 degrees;
 - (iii) the ramp angle shall be at least 25 degrees;
 - (iv) the ground clearance under the front axle shall be at least 250 mm;
 - (v) the ground clearance between axles shall be at least 300 mm;
 - (vi) the ground clearance under the rear axle shall be at least 250 mm.
- 4.3. M_3 or N_3 vehicles whose maximum mass exceeds 12 tonnes shall be subcategorised as off-road vehicles if they satisfy the condition set out in point (a) or both conditions set out in points (b) and (c):
- (a) all their axles are driven simultaneously, irrespective of whether one or more powered axles can be disengaged;
 - (b) (i) at least half of the axles (or two axles out of the three in the case of a three axle vehicle and *mutatis mutandis* in the case of a five axle vehicle) is designed to be driven simultaneously, irrespective of whether one powered axle can be disengaged;
 - (ii) there is at least one differential locking mechanism or a mechanism having similar effect;
 - (iii) they are able to climb a 25 % gradient as solo vehicle;
 - (c) they satisfy at least four out of the following six requirements:
 - (i) the approach angle shall be at least 25 degrees;
 - (ii) the departure angle shall be at least 25 degrees;
 - (iii) the ramp angle shall be at least 25 degrees;
 - (iv) the ground clearance under the front axle shall be at least 250 mm;
 - (v) the ground clearance between axles shall be at least 300 mm;
 - (vi) the ground clearance under the rear axle shall be at least 250 mm.
- 4.4. The procedure for checking compliance with the geometrical provisions referred to in this section shall be set out in Appendix 1.

5. **Special purpose vehicles**

| | Name | Code | Definition |
|-------|------------------------------------|------|---|
| 5.1. | Motor caravan | SA | A vehicle of category M with living accommodation space which contains the following equipment as a minimum: (a) seats and table; (b) sleeping accommodation which may be converted from the seats; (c) cooking facilities; (d) storage facilities. This equipment shall be rigidly fixed to the living compartment. However, the table may be designed to be easily removable. |
| 5.2. | Armoured vehicle | SB | a vehicle intended for the protection of conveyed persons or goods with anti-bullet armour plating. |
| 5.3. | Ambulance | SC | a vehicle of category M intended for the transport of sick or injured persons and having special equipment for such purpose. The patient compartment shall comply with the technical requirements of Standard EN 1789:2007 on "Medical vehicles and their equipment – Road ambulances" with the exception of Section 6.5 "List of equipment". |
| 5.4. | Hearse | SD | a vehicle of category M intended for the transport of deceased persons and having special equipment for such purpose. |
| 5.5. | Wheelchair accessible vehicle | SH | a vehicle of category M ₁ constructed or converted specifically so that they accommodate one or more persons seated in their wheelchairs when travelling on the road. |
| 5.6. | Trailer caravan | SE | a vehicle of category O as defined in term 3.2.1.3 of Standard ISO 3833:1977. |
| 5.7. | Mobile crane | SF | a vehicle of category N ₃ , not fitted for the carriage of goods, provided with a crane whose lifting moment is equal to or higher than 400 kNm. |
| 5.8. | Special group | SG | a special purpose vehicle which does not enter in any of the definitions mentioned in this section. |
| 5.9. | Converter dolly | SJ | a vehicle of category O equipped with a fifth-wheel coupling to support a semi-trailer with a view to converting the latter into a trailer. |
| 5.10. | Exceptional load transport trailer | SK | a vehicle of category O ₄ intended for the transport of indivisible loads that is subject to speed and traffic restrictions because of its dimensions. Under this term are also included hydraulic modular trailers irrespective of the number of modules. |

6. **Remarks**

6.1. Type-approval shall not be granted:

- (a) to converter dolly as defined in Section 5 of Part A of this Annex;
- (b) to rigid drawbar trailers as defined in Section 4 of Part C of this Annex;
- (c) to trailers in which persons may be carried when travelling on the road.

6.2. Paragraph 6.1 is without prejudice to the provisions of Article 23 on national small series type-approval.

PART B

Criteria for vehicle types, variants and versions1. **Category M₁**

1.1. Vehicle type

1.1.1. A "vehicle type" shall consist of vehicles which have all of the following features in common:

- (a) the manufacturer's company name.

A change in the legal form of ownership of the company does not require that a new approval has to be granted;

- (b) the design and assembly of the essential parts of the body structure in the case of a self-supporting body.

The same shall apply *mutatis mutandis* to vehicles the bodywork of which is bolted on or welded to a separate frame;

- (c) in the case of multi-stage built vehicles, the manufacturer and the type of the previous stage vehicle.

1.1.2. By way of derogation from the requirements of point 1.1.1(b), when the manufacturer uses the floor portion of the body structure as well as the essential constituent elements forming the front part of the body structure located directly in front of the windscreen bay, in the construction of different kinds of bodywork (for example a saloon and a coupe), those vehicles may be considered as belonging to the same type. Evidence thereof shall be provided by the manufacturer.

1.1.3. A type shall consist of at least one variant and one version.

1.2. Variant

1.2.1. A "variant" within a vehicle type shall group the vehicles which have all of the following construction features in common:

- (a) the number of lateral doors or the type of bodywork as defined in Section 1 of Part C when the manufacturer uses the criterion of point 1.1.2;
- (b) the power plant with regard to the following construction features:
- (i) the type of energy supply (internal combustion engine, electric motor or other);
 - (ii) the working principle (positive ignition, compression ignition or other);
 - (iii) the number and arrangement of cylinders in the case of internal combustion engine (L4, V6 or other);
- (c) the number of axles;
- (d) the number, and interconnection of powered axles;
- (e) the number of steered axles;
- (f) the stage of completion (e.g. complete/incomplete).

1.3. Version

1.3.1. A "version" within a variant shall group the vehicles which have all the following features in common:

- (a) the technically permissible maximum laden mass;
- (b) the engine capacity in the case of internal combustion engine;
- (c) the maximum engine power output or the maximum continuous rated power (electric motor);
- (d) the nature of the fuel (petrol, gas oil, LPG, bi-fuel or other);
- (e) the maximum number of seating positions;
- (f) drive-by sound level;
- (g) exhaust emission level (for example Euro 5, Euro 6 or other);
- (h) combined or weighted, combined CO₂ emissions;
- (i) electric energy consumption (weighted, combined);
- (j) combined or weighted, combined fuel consumption;
- (k) the existence of a unique set of innovative technologies, as specified in Article 12 of Regulation (EC) No 443/2009 ⁽¹⁾.

⁽¹⁾ OJ L 140, 5.6.2009, p. 1.

2. Categories M₂ and M₃

2.1. Vehicle type

2.1.1. A "vehicle type" shall consist of vehicles which have all of the following features in common:

(a) the manufacturer's company name.

A change in the legal form of ownership of the company does not require that a new approval has to be granted;

(b) the category;

(c) the following aspects of construction and design:

(i) the design and construction of the essential constituent elements forming the chassis;

(ii) the design and construction of the essential constituent elements forming the body structure in the case of a self-supporting body;

(d) the number of decks (single or double);

(e) the number of sections (rigid/articulated);

(f) the number of axles;

(g) the mode of energy supply (on-board or off-board);

(h) in the case of multi-stage built vehicles, the manufacturer and the type of the previous stage vehicle.

2.1.2. A type shall consist of at least one variant and one version.

2.2. Variant

2.2.1. A "variant" within a vehicle type shall group the vehicles which have all of the following construction features in common:

(a) the type of bodywork as defined in Section 2 of Part C;

(b) the class or combination of classes of vehicles as defined in point 2.1.1 of Annex I to Directive 2001/85/EC (only in the case of complete and completed vehicles);

(c) the stage of completion (e.g. complete/incomplete/completed);

(d) the power plant with regard to the following construction features:

(i) the type of energy supply (internal combustion engine, electric motor or other);

(ii) the working principle (positive ignition, compression ignition or other);

(iii) the number and arrangement of cylinders in the case of internal combustion engine (L6, V8 or other).

2.3. Version

2.3.1. A "version" within a variant shall group the vehicles which have all the following features in common:

(a) the technically permissible maximum laden mass;

(b) the ability of the vehicle to tow a trailer or not;

(c) the engine capacity in the case of internal combustion engine;

(d) the maximum engine power output or the maximum continuous rated power (electric motor);

(e) the nature of the fuel (petrol, gas oil, LPG, bi-fuel or other);

(f) drive-by sound level;

(g) exhaust emission level (for example Euro IV, Euro V or other).

3. Category N₁

3.1. Vehicle type

3.1.1. A "vehicle type" shall consist of vehicles which have all of the following features in common:

(a) the manufacturer's company name.

A change in the legal form of ownership of the company does not require that a new approval has to be granted;

- (b) the design and assembly of the essential parts of the body structure in the case of a self-supporting body;
 - (c) the design and the construction of the essential constituent elements forming the chassis in the case of a non self-supporting body;
 - (d) in the case of multi-stage built vehicles, the manufacturer and the type of the previous stage vehicle.
- 3.1.2. By way of derogation from the requirements of point 3.1.1(b), when the manufacturer uses the floor portion of the body structure as well the essential constituent elements forming the front part of the body structure located directly in front of the windscreen bay, in the construction of different kinds of bodywork (for example a van and a chassis-cab, different wheelbases and different roof heights), those vehicles may be considered as belonging to the same type. Evidence thereof shall be provided by the manufacturer.
- 3.1.3. A type shall consist of at least one variant and one version.
- 3.2. Variant
- 3.2.1. A "variant" within a vehicle type shall group the vehicles which have all of the following construction features in common:
- (a) the number of lateral doors or the type of bodywork as defined in Section 3 of Part C (for complete and completed vehicles) when the manufacturer uses the criterion of point 3.1.2;
 - (b) the stage of completion (e.g. complete/incomplete/completed);
 - (c) the power plant with regard to the following construction features:
 - (i) the type of energy supply (internal combustion engine, electric motor or other);
 - (ii) the working principle (positive ignition, compression ignition or other);
 - (iii) the number and arrangement of cylinders in the case of internal combustion engine (L6, V8 or other);
 - (d) the number of axles;
 - (e) the number and interconnection of powered axles;
 - (f) the number of steered axles.
- 3.3. Version
- 3.3.1. A "version" within a variant shall group the vehicles which have all the following features in common:
- (a) the technically permissible maximum laden mass;
 - (b) the engine capacity in the case of internal combustion engine;
 - (c) the maximum engine power output or maximum continuous rated power (electric motor);
 - (d) the nature of the fuel (petrol, gas oil, LPG, bi-fuel or other);
 - (e) the maximum number of seating positions;
 - (f) drive-by sound level;
 - (g) exhaust emission level (for example Euro 5, Euro 6 or other);
 - (h) combined or weighted, combined CO₂ emissions;
 - (i) electric energy consumption (weighted, combined);
 - (j) combined or weighted, combined fuel consumption.
4. **Categories N₂ and N₃**
- 4.1. Vehicle type
- 4.1.1. A "vehicle type" shall consist of vehicles which have all of the following essential features in common:
- (a) the manufacturer's company name.
 - A change in the legal form of ownership of the company does not require that a new approval has to be granted;
 - (b) the category;
 - (c) the design and construction of the chassis that are common to a single line of product;
 - (d) the number of axles;
 - (e) in the case of multi-stage built vehicles, the manufacturer and the type of the previous stage vehicle.
- 4.1.2. A type shall consist of at least one variant and one version.

4.2. Variant

4.2.1. A "variant" within a vehicle type shall group the vehicles which have all of the following construction features in common:

- (a) the body structural concept or type of bodywork as referred to in Section 3 of Part C and in Appendix 2 (only for complete and completed vehicles);
- (b) the stage of completion (e.g. complete/incomplete/completed);
- (c) the power plant with regard to the following construction features:
 - (i) the type of energy supply (internal combustion engine, electric motor or other);
 - (ii) the working principle (positive ignition, compression ignition or other);
 - (iii) the number and arrangement of cylinders in the case of internal combustion engine (L6, V8 or other);
- (d) the number and interconnection of powered axles;
- (e) the number of steered axles.

4.3. Version

4.3.1. A "version" within a variant shall group the vehicles which have all the following features in common:

- (a) the technically permissible maximum laden mass;
- (b) the ability or not to tow a trailer as follows:
 - (i) an unbraked trailer;
 - (ii) a trailer with an inertia (or overrun) braking system as defined in point 2.12 of UNECE Regulation No 13;
 - (iii) a trailer with a continuous or semi-continuous braking system as defined in points 2.9 and 2.10 of UNECE Regulation No 13;
 - (iv) a trailer of category O₄ that results in a maximum mass of the combination not exceeding 44 tonnes;
 - (v) a trailer of category O₄ that results in a maximum mass of the combination exceeding 44 tonnes;
- (c) the engine capacity;
- (d) the maximum engine power output;
- (e) the nature of the fuel (petrol, gas oil, LPG, bi-fuel or other);
- (f) drive-by sound level;
- (g) exhaust emission level (for example Euro IV, Euro V or other).

5. **Categories O₁ and O₂**

5.1. Vehicle type

5.1.1. A "vehicle type" shall consist of vehicles which have all of the following features in common:

- (a) the manufacturer's company name.

A change in the legal form of ownership of the company does not require that a new approval has to be granted;

- (b) the category;
- (c) the concept as defined in section 4 of Part C;

- (d) the following aspects of construction and design:
 - (i) the design and construction of the essential constituent elements forming the chassis;
 - (ii) the design and construction of the essential constituent elements forming the body structure in the case of a self-supporting body;
 - (e) the number of axles;
 - (f) in the case of multi-stage built vehicles, the manufacturer and the type of the previous stage vehicle.
- 5.1.2. A type shall consist of at least one variant and one version.
- 5.2. Variant
- 5.2.1. A "variant" within a vehicle type shall group the vehicles which have all of the following construction features in common:
- (a) the kind of bodywork as referred to in Appendix 2 (for complete and completed vehicles);
 - (b) the stage of completion (e.g. complete/incomplete/completed);
 - (c) the type of braking system (e.g. unbraked/inertia/power).
- 5.3. Version
- 5.3.1. A "version" within a variant shall group the vehicles which have all the following features in common:
- (a) the technically permissible maximum laden mass;
 - (b) the concept of the suspension (air, steel or rubber suspension, torsion bar or other);
 - (c) the concept of the drawbar (triangle, tube or other).
6. **Categories O₃ and O₄**
- 6.1. Vehicle type
- 6.1.1. A "vehicle type" shall consist of vehicles which have all of the following features in common:
- (a) the manufacturer's company name.

A change in the legal form of ownership of the company does not require that a new approval has to be granted;
 - (b) the category;
 - (c) the concept of the trailer with relation to the definitions in section 4 of Part C;
 - (d) the following aspects of construction and design:
 - (i) the design and construction of the essential constituent elements forming the chassis;
 - (ii) the design and construction of the essential constituent elements forming the body structure in the case of trailers with a self-supporting body;
 - (e) the number of axles;
 - (f) in the case of multi-stage built vehicles, the manufacturer and the type of the previous stage vehicle.
- 6.1.2. A type shall consist of at least one variant and one version.
- 6.2. Variants
- 6.2.1. A "variant" within a vehicle type shall group the vehicles which have all of the following construction and design features in common:
- (a) the kind of bodywork as referred to in Appendix 2 (for complete and completed vehicles);
 - (b) the stage of completion (e.g. complete/incomplete/completed);
 - (c) the concept of the suspensions (steel, air or hydraulic suspension);
 - (d) the following technical features:
 - (i) the capability or not for the chassis to be extendible;
 - (ii) the deck height (normal, low loader, semi-low loader etc.).

6.3. Versions

6.3.1. A "version" within a variant shall group the vehicles which have all the following features in common:

- (a) the technically permissible maximum laden mass;
- (b) the subdivisions or combination of subdivisions referred to in points 3.2 and 3.3 of Annex I to Directive 96/53/EC into which the axle spacing between two consecutive axles forming a group belongs;
- (c) the definition of the axles in the following respects:
 - (i) lift axles (number and position);
 - (ii) loadable axles (number and position);
 - (iii) steered axle (number and position).

7. Common requirements for all vehicle categories

7.1. When a vehicle falls into several categories because of its maximum mass or the number of seating positions or both, the manufacturer may select to use the criteria of one or the other vehicle category for the definition of the variants and the versions.

7.1.1. Examples:

- (a) a vehicle "A" may be type-approved as N_1 (3,5 tonnes) and N_2 (4,2 tonnes) in relation to its maximum mass. In such a case, the parameters mentioned in category N_1 may be used also for the vehicle that falls into category N_2 (or vice-versa);
- (b) A vehicle "B" may be type-approved as M_1 and M_2 in relation to the number of seating positions ($7 + 1$ or $10 + 1$), the parameters mentioned in category M_1 may be used also for the vehicle that falls into category M_2 (or vice-versa).

7.2. A vehicle of category N may be type-approved against the provisions required for category M_1 or M_2 , as the case may be, when it is intended to be converted into a vehicle of that category during the next step of a multi-stage type-approval procedure.

7.2.1. This option shall only be permitted for incomplete vehicles.

Such vehicles shall be identified by a specific variant code given by the manufacturer of the base vehicle.

7.3. Type-, variant- and version designations

7.3.1. The manufacturer shall allocate an alphanumeric code to each vehicle type, variant and version, made up of Roman letters and/or Arabic numerals.

The use of brackets and hyphens is permitted provided they do not replace a letter or a numeral.

7.3.2. The whole code shall be designated: Type-Variant-Version or "TVV".

7.3.3. The TVV shall clearly and unequivocally identify a unique combination of technical features in relation to the criteria defined in Part B of this Annex.

7.3.4. The same manufacturer may use the same code in order to define a vehicle type when the latter falls in two or more categories.

7.3.5. The same manufacturer shall not use the same code in order to define a vehicle type for more than one type-approval within the same vehicle category.

7.4. Number of characters for the TVV

7.4.1. The number of characters shall not exceed:

- (a) 15 for the code of the vehicle type;
- (b) 25 for the code of one variant;
- (c) 35 for the code of one version.

7.4.2. The complete alphanumeric "TVV" shall not contain more than 75 characters.

7.4.3. When the TVV is used as a whole, a space shall be left between the type, the variant and the version.

Example of such TVV: 159AF[...space]0054[...space]977K(BE).

PART C

Definitions of types of bodywork**0. General**

- 0.1. The type of bodywork referred to in Section 9 of Annex I and Part 1 of Annex III as well as the code for bodywork referred to in Item 38 of Annex IX shall be indicated by means of codes.

The list of codes shall apply primarily to complete and completed vehicles.

- 0.2. As regards vehicles of categories M, the type of bodywork shall consist of two letters as specified in Sections 1 and 2.
- 0.3. As regards vehicles of categories N and O, the type of bodywork shall consist of two letters as referred to in Sections 3 and 4.
- 0.4. Where necessary (especially for the types of bodywork referred to respectively in points 3.1 and 3.6 and in points 4.1 to 4.4), they shall be supplemented by two digits.
- 0.4.1. The list of digits shall be laid down in Appendix 2 to this Annex.
- 0.5. For special purpose vehicles, the type of bodywork to be used shall be linked to the category of the vehicle.

1. Vehicles belonging to category M₁

| Ref. | Code | Name | Definition |
|------|------|-----------------------|---|
| 1.1. | AA | Saloon | a vehicle defined in term 3.1.1.1 of Standard ISO 3833:1977, fitted with at least four side windows. |
| 1.2. | AB | Hatchback | a saloon as defined in 1.1 with a hatch at the rear end of the vehicle. |
| 1.3. | AC | Station wagon | a vehicle defined in term 3.1.1.4 of Standard ISO 3833:1977. |
| 1.4. | AD | Coupé | a vehicle defined in term 3.1.1.5 of Standard ISO 3833:1977. |
| 1.5. | AE | Convertible | a vehicle defined in terms No 3.1.1.6 of Standard ISO 3833:1977. However a convertible may have no door. |
| 1.6. | AF | Multi-purpose vehicle | a vehicle other than AG and those mentioned in AA to AE intended for carrying persons and their luggage or occasionally goods, in a single compartment. |
| 1.7. | AG | Truck station wagon | a vehicle defined in terms No 3.1.1.4.1 of Standard ISO 3833:1977. However, the luggage compartment must be completely separated from the passenger compartment. In addition, the reference point of the driver's seating position needs not to be at least at 750 mm above the surface supporting the vehicle. |

2. Vehicles belonging to category M₂ or M₃

| Ref. | Code | Name | Definition |
|------|------|---------------------------------|---|
| 2.1. | CA | Single-deck vehicle | a vehicle where the spaces provided for persons are arranged in a single level or in a way that they do not constitute two superimposed levels; |
| 2.2. | CB | Double-deck vehicle | a vehicle defined in point 2.1.6 of Annex I to Directive 2001/85/EC; |
| 2.3. | CC | Single-deck articulated vehicle | a vehicle defined in point 2.1.3 of Annex I to Directive 2001/85/EC with a single deck; |
| 2.4. | CD | Double-deck articulated vehicle | a vehicle defined in point 2.1.3.1 of Annex I to Directive 2001/85/EC; |

| Ref. | Code | Name | Definition |
|-------|------|---|---|
| 2.5. | CE | Low-floor single-deck vehicle | a vehicle defined in point 2.1.4 of Annex I to Directive 2001/85/EC with a single deck; |
| 2.6. | CF | Low-floor double-deck vehicle | a vehicle defined in point 2.1.4 of Annex I to Directive 2001/85/EC with a double deck; |
| 2.7. | CG | Articulated low-floor single-deck vehicle | a vehicle that combines the technical features of entries 2.3 and 2.5; |
| 2.8. | CH | Articulated low-floor double-deck vehicle | a vehicle that combines the technical features of entries 2.4 and 2.6; |
| 2.9. | CI | Open top single deck vehicle | a vehicle with partial roof or without roof; |
| 2.10. | CJ | Open top double deck vehicle | a vehicle without roof over all or part of its upper deck; |
| 2.11. | CX | Bus chassis | an incomplete vehicle with just chassis rails or tube assembly, power train, axles, which is intended to be completed with bodywork, customised to the needs of the transport operator. |

3. Motor vehicles of category N₁, N₂ or N₃

| Ref. | Code | Name | Definition |
|------|------|-------------------------------|---|
| 3.1. | BA | Lorry | a vehicle which is designed and constructed exclusively or principally for conveying goods. It may also tow a trailer. |
| 3.2. | BB | Van | a lorry with the compartment where the driver is located and cargo area within a single unit; |
| 3.3. | BC | Tractor unit for semi-trailer | a towing vehicle which is designed and constructed exclusively or principally to tow semi-trailers; |
| 3.4. | BD | Road tractor | a towing vehicle which is designed and constructed exclusively to tow trailers other than semi-trailers; |
| 3.5. | BE | Pick-up truck | a vehicle of a maximum mass not exceeding 3 500 kg in which the seating positions and the cargo area are not located in a single compartment; |
| 3.6. | BX | Chassis-cab or chassis-cowl | an incomplete vehicle with just a cabin (complete or partial), chassis rails, power train, axles, which is intended to be completed with bodywork, customised to the needs of the transport operator. |

4. Vehicles of category O

| Ref. | Code | Name | Definition |
|------|------|-----------------|--|
| 4.1. | DA | Semi-trailer | a trailer which is designed and constructed to be coupled to a tractor unit or to a converter dolly and to impose a substantial vertical load on the towing vehicle or on the converter dolly. The coupling to be used for a vehicle combination shall consist of a king pin and a fifth wheel. |
| 4.2. | DB | Drawbar trailer | a trailer having at least two axles, of which at least one is a steered axle: (a) equipped with a towing device which can move vertically (in relation to the trailer) and (b) that transmits less than 100 daN as a static vertical load to the towing vehicle. |

| Ref. | Code | Name | Definition |
|------|------|-----------------------|---|
| 4.3. | DC | Centre-axle trailer | a trailer where the axle(s) is (are) positioned close to the centre of gravity of the vehicle (when uniformly loaded) so that only a small static vertical load, not exceeding 10 % of that corresponding to the maximum mass of the trailer or a load of 1 000 daN (whichever is the lesser) is transmitted to the towing vehicle. |
| 4.4. | DE | Rigid drawbar trailer | <p>a trailer with one axle or one group of axles fitted with a drawbar which transmits a static load not exceeding 4 000 daN to the towing vehicle due to its construction and which does not meet the definition of a centre-axle trailer.</p> <p>The coupling to be used for a vehicle combination shall not consist of a king pin and a fifth wheel.</p> |

*Appendix 1***Procedure for checking whether a vehicle can be categorised as off-road vehicle****0. General**

- 0.1. For the purposes of classification of a vehicle as off-road vehicle, the procedure described in this Appendix shall apply.

1. Test conditions for geometric measurements

- 1.1. Vehicles belonging to category M₁ or N₁ shall be in unloaded conditions with a manikin of the 50th percentile male installed on the driver's seat and fitted with coolant fluid, lubricants, fuel, tools, spare-wheel (if fitted as OEM equipment).

The manikin may be replaced by a similar device having the same mass.

- 1.2. Vehicles other than those referred to in point 1.1 shall be loaded to their technically permissible maximum laden mass.

The distribution of the mass on the axles shall be the one that represents the worst case with respect to compliance with the respective criteria.

- 1.3. A vehicle representative of the type shall be submitted to the technical service in the conditions specified in point 1.1 or 1.2. The vehicle shall be in a stationary position with its wheels set straight ahead.

The ground on which measurements are made shall be as flat and horizontal (maximum of inclination 0,5 %) as possible.

2. Measurement of approach, departure and ramp angles

- 2.1. The approach angle shall be measured in accordance with Item 6.10 of Standard ISO 612:1978.
- 2.2. The departure angle shall be measured in accordance with Item 6.11 of Standard ISO 612:1978.
- 2.3. The ramp angle shall be measured in accordance with Item 6.9 of Standard ISO 612:1978.
- 2.4. When measuring the departure angle rear underrun protection devices which are adjustable in height may be set in the upper position.
- 2.5. The prescription in point 2.4 shall not be construed as an obligation for the base vehicle to be fitted with a rear underrun protection as original equipment. However, the base vehicle manufacturer shall inform the next stage manufacturer that the vehicle has to comply with the requirements on departure angle when fitted with a rear underrun protection.

3. Measurement of ground clearance

- 3.1. Ground clearance between the axles
- 3.1.1. "Ground clearance between the axles" means the shortest distance between the ground plane and the lowest fixed point of the vehicle.

For the application of the definition, the distance between the last axle of a front group of axle and the first axle of a rear group of axle shall be considered.

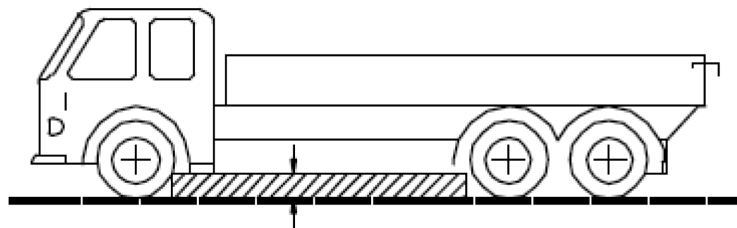

3.1.2. No rigid part of the vehicle may project into the shaded area shown on the figure.

3.2. Ground clearance beneath one axle

3.2.1. "Ground clearance beneath one axle" means the distance beneath the highest point of the arc of a circle passing through the centre of the tyre footprint of the wheels on one axle (the inner wheels in the case of twin tyres) and touching the lowest fixed point of the vehicle between the wheels.

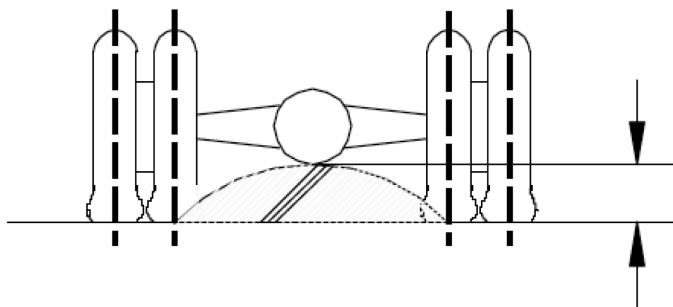

3.2.2. Where appropriate, the measurement of ground clearance shall be conducted on each of the several axles of a group of axles.

4. Gradeability

4.1. "Gradeability" means the ability of a vehicle to negotiate a gradient.

4.2. To the effect of checking the gradeability of an incomplete and a complete vehicle of category M₂, M₃, N₂ and N₃, a test shall be performed.

4.3. The test shall be conducted by the technical service on a vehicle representative of the type to be tested.

4.4. At the request of the manufacturer and under the conditions specified in Annex XVI, the gradeability of a vehicle type may be demonstrated by virtual testing.

5. Test conditions and pass-fail criterion

5.1. Until 31 October 2014, the conditions set out in section 7.5 of Annex I to Directive 97/27/EC shall apply.

As from 1 November 2014, test conditions adopted under Regulation (EC) No 661/2009 of the European Parliament and of the Council ⁽¹⁾ in accordance with Article 14 of that Regulation shall apply.

5.2. The vehicle shall climb the gradient at a steady speed without any wheel slipping, longitudinally or laterally.

⁽¹⁾ OJ L 200, 31.7.2009, p. 1.

*Appendix 2***Digits used to supplement the codes to be used for various kinds of bodywork**

- 01 Flat bed;
 - 02 Drop-side;
 - 03 Box body;
 - 04 Conditioned body with insulated walls and equipment to maintain the interior temperature;
 - 05 Conditioned body with insulated walls but without equipment to maintain the interior temperature;
 - 06 Curtain-sided;
 - 07 Swap body (interchangeable superstructure);
 - 08 Container carrier;
 - 09 Vehicles fitted with hook lift;
 - 10 Tipper;
 - 11 Tank;
 - 12 Tank intended for transport of dangerous goods;
 - 13 Livestock carrier;
 - 14 Vehicle transporter;
 - 15 Concrete mixer;
 - 16 Concrete pump vehicle;
 - 17 Timber;
 - 18 Refuse collection vehicle;
 - 19 Street sweeper, cleansing and drain clearing;
 - 20 Compressor;
 - 21 Boat carrier;
 - 22 Glider carrier;
 - 23 Vehicles for retail or display purposes;
 - 24 Recovery vehicle;
 - 25 Ladder vehicle;
 - 26 Crane lorry (other than a mobile crane as defined in Section 5 of Part A of Annex II);
 - 27 Aerial work platform vehicle;
 - 28 Digger derrick vehicle;
 - 29 Low floor trailer;
 - 30 Glazing transporter;
 - 31 Fire engine;
 - 99 Bodywork that is not included in the present list.'
-

ANNEX II

Annex IV to Directive 2007/46/EC is amended as follows:

(1) the title of Annex IV is replaced by **'REQUIREMENTS FOR THE PURPOSE OF EC TYPE-APPROVAL OF VEHICLES'**;

(2) item 43 of Part I of Annex IV is replaced by the following:

| | | | | | | | | | | | | | | |
|-----|---------------------------|----------------------|------------------------|--|--|--|--|---|---|---|---|---|---|---|
| '43 | Spray suppression systems | Directive 91/226/EEC | L 103, 23.4.1991, p. 5 | | | | | x | x | x | x | x | x | x |
|-----|---------------------------|----------------------|------------------------|--|--|--|--|---|---|---|---|---|---|---|

(3) the title of the Appendix to Annex IV is replaced by **'Requirements for type-approval of vehicles belonging to the category M₁, produced in small series pursuant to Article 22'**.

ANNEX III

Annex IX to Directive 2007/46/EC is amended as follows:

- (1) The text of the entry 31 in “Side 2 - Vehicle category N₂ (complete and completed vehicles)” of the template of the certificate of conformity is replaced by the following text:

'31. Position of lift axle(s): ...'

- (2) The text of the entry 31 in “Side 2 - Vehicle category N₃ (complete and completed vehicles)” of the template of the certificate of conformity is replaced by the following text:

'31. Position of lift axle(s): ...'

- (3) The text of the entry 31 in “Side 2 - Vehicle categories O₁ and O₂ (complete and completed vehicles)” of the template of the certificate of conformity is replaced by the following text:

'31. Position of lift axle(s): ...'

- (4) The text of the entry 31 in “Side 2 - Vehicle categories O₃ and O₄ (complete and completed vehicles)” of the template of the certificate of conformity is replaced by the following text:

'31. Position of lift axle(s): ...'

- (5) The text of the entry 31 in “Side 2 - Vehicle category N₂ (incomplete vehicles)” of the template of the certificate of conformity is replaced by the following text:

'31. Position of lift axle(s): ...'

- (6) The text of the entry 31 in “Side 2 - Vehicle category N₃ (incomplete vehicles)” of the template of the certificate of conformity is replaced by the following text:

'31. Position of lift axle(s): ...'

- (7) The text of the entry 31 in “Side 2 - Vehicle categories O₁ and O₂ (incomplete vehicles)” of the template of the certificate of conformity is replaced by the following text:

'31. Position of lift axle(s): ...'

- (8) The text of the entry 31 in “Side 2 - Vehicle categories O₃ and O₄ (incomplete vehicles)” of the template of the certificate of conformity is replaced by the following text:

'31. Position of lift axle(s): ...'

- (9) The text of the explanatory notes relating to Annex IX is amended as follows:

(a) The last sentence of the explanatory note (a) is deleted;

(b) The following sentence is added to the explanatory note (e):

'For a centre-axle trailer with one single axle, indicate the horizontal distance between the vertical axis of the coupling and the centre of the axle.'

ANNEX IV

Annex XI to Directive 2007/46/EC is amended as follows:

(1) item 43 of Appendix 2 to Annex XI is replaced by the following:

| | | | | | | | | | | | | | |
|-----|---------------------------|----------------------|--|--|--|--|---|---|---|---|---|---|----|
| '43 | Spray suppression systems | Directive 91/226/EEC | | | | | x | x | x | x | x | x | x' |
|-----|---------------------------|----------------------|--|--|--|--|---|---|---|---|---|---|----|

(2) item 43 of Appendix 4 to Annex XI is replaced by the following:

| | | | | | | | | | | | | | |
|-----|---------------------------|----------------------|--|--|--|--|---|---|---|---|---|---|----|
| '43 | Spray suppression systems | Directive 91/226/EEC | | | | | x | x | x | x | x | x | x' |
|-----|---------------------------|----------------------|--|--|--|--|---|---|---|---|---|---|----|

(3) the following Appendix 6 is inserted after Appendix 5 and before the "Meaning of letters":

'Appendix 6

Exceptional load transport trailers

| Item | Subject | Regulatory act reference | Trailer of category O ₄ |
|------|--|--------------------------|------------------------------------|
| 3 | Fuel tanks/rear protective devices | Directive 70/221/EEC | X |
| 4 | Rear registration plate space | Directive 70/222/EEC | X |
| 5 | Steering effort | Directive 70/311/EEC | X |
| 9 | Braking | Directive 71/320/EEC | X |
| 10 | Radio interference (electromagnetic compatibility) | Directive 72/245/EEC | X |
| 18 | Plates (statutory) | Directive 76/114/EEC | X |
| 20 | Installation of lighting and light signalling devices | Directive 76/756/EEC | A + N |
| 21 | Reflex reflectors | Directive 76/757/EEC | X |
| 22 | End-outline, front position (side), rear-position (side), stop, side marker, daytime running lamps | Directive 76/758/EEC | X |
| 23 | Direction indicators | Directive 76/759/EEC | X |
| 24 | Rear registration plate lamps | Directive 76/760/EEC | X |
| 28 | Rear fog lamps | Directive 77/538/EEC | X |
| 29 | Reversing lamps | Directive 77/539/EEC | X |
| 36 | Heating systems | Directive 2001/56/EC | N/A |
| 42 | Lateral protection | Directive 89/297/EEC | A |
| 43 | Spray-suppression systems | Directive 91/226/EEC | A |

| Item | Subject | Regulatory act reference | Trailer of category O ₄ |
|------|---------------------------|-----------------------------|------------------------------------|
| 46 | Tyres | Directive 92/23/EEC | I |
| 48 | Masses and dimensions | Directive 97/27/EC | X |
| 50 | Couplings | Directive 94/20/EC | X |
| 63 | General safety Regulation | Regulation (EC) No 661/2009 | P/A' |

(4) the 'Meaning of letters' shall be amended as follows:

(a) point L shall be replaced by the following text:

'L: Application limited to seats designated for normal use when the vehicle is travelling on the road. At least anchorages for lap belts are required in the rear seating positions. Seats which are not designated for use when the vehicle is travelling on the road shall be clearly identified to users by means of a pictogram or a sign with an appropriate text.'

(b) the following point shall be inserted after point N/A:

'P/A: This regulatory act is partially applicable. The precise scope of application is established in the implementing measures to Regulation (EC) No 661/2009.';

(c) the following point shall be inserted after point H

'I: Tyres must be type-approved under the requirements of UNECE Regulation No 54 even if the maximum design speed of the vehicle is less than 80 km/h.

The load capacity may be adjusted in relation to the maximum design speed of the trailer in agreement with the tyre manufacturer.'
