

This document is meant purely as a documentation tool and the institutions do not assume any liability for its contents

**► B** **COMMISSION REGULATION (EC) No 1623/2000**  
**of 25 July 2000**

**laying down detailed rules for implementing Regulation (EC) No 1493/1999 on the common organisation of the market in wine with regard to market mechanisms**

(OJ L 194, 31.7.2000, p. 45)

Amended by:

		Official Journal		
		No	page	date
► <u>M1</u>	Commission Regulation (EC) No 2409/2000 of 30 October 2000	L 278	3	31.10.2000
► <u>M2</u>	Commission Regulation (EC) No 2786/2000 of 19 December 2000	L 323	4	20.12.2000
► <u>M3</u>	Commission Regulation (EC) No 545/2001 of 20 March 2001	L 81	21	21.3.2001
► <u>M4</u>	Commission Regulation (EC) No 1282/2001 of 28 June 2001	L 176	14	29.6.2001
► <u>M5</u>	Commission Regulation (EC) No 1660/2001 of 16 August 2001	L 221	8	17.8.2001
► <u>M6</u>	Commission Regulation (EC) No 2022/2001 of 15 October 2001	L 273	17	16.10.2001
► <u>M7</u>	Commission Regulation (EC) No 2047/2001 of 18 October 2001	L 276	15	19.10.2001
► <u>M8</u>	Commission Regulation (EC) No 2429/2001 of 12 December 2001	L 328	28	13.12.2001
► <u>M9</u>	Commission Regulation (EC) No 2464/2001 of 14 December 2001	L 331	25	15.12.2001
► <u>M10</u>	Commission Regulation (EC) No 1315/2002 of 19 July 2002	L 192	24	20.7.2002
► <u>M11</u>	Commission Regulation (EC) No 1795/2002 of 9 October 2002	L 272	15	10.10.2002
► <u>M12</u>	Commission Regulation (EC) No 625/2003 of 2 April 2003	L 90	4	8.4.2003
► <u>M13</u>	Commission Regulation (EC) No 1183/2003 of 2 July 2003	L 165	20	3.7.2003
► <u>M14</u>	Commission Regulation (EC) No 1411/2003 of 7 August 2003	L 201	12	8.8.2003
► <u>M15</u>	Commission Regulation (EC) No 1710/2003 of 26 September 2003	L 243	98	27.9.2003
► <u>M16</u>	Commission Regulation (EC) No 908/2004 of 29 April 2004	L 163	56	30.4.2004
► <u>M17</u>	Commission Regulation (EC) No 1774/2004 of 14 October 2004	L 316	61	15.10.2004
► <u>M18</u>	Commission Regulation (EC) No 535/2005 of 6 April 2005	L 88	9	7.4.2005
► <u>M19</u>	Commission Regulation (EC) No 616/2005 of 21 April 2005	L 103	15	22.4.2005
► <u>M20</u>	Commission Regulation (EC) No 1219/2005 of 28 July 2005	L 199	45	29.7.2005
► <u>M21</u>	Commission Regulation (EC) No 1820/2005 of 8 November 2005	L 293	8	9.11.2005
► <u>M22</u>	Commission Regulation (EC) No 1221/2006 of 11 August 2006	L 221	3	12.8.2006
► <u>M23</u>	Commission Regulation (EC) No 1713/2006 of 20 November 2006	L 321	11	21.11.2006
► <u>M24</u>	Commission Regulation (EC) No 2016/2006 of 19 December 2006	L 384	38	29.12.2006
► <u>M25</u>	Commission Regulation (EC) No 897/2007 of 27 July 2007	L 196	20	28.7.2007
► <u>M26</u>	Commission Regulation (EC) No 923/2007 of 1 August 2007	L 201	9	2.8.2007
► <u>M27</u>	Commission Regulation (EC) No 1433/2007 of 5 December 2007	L 320	18	6.12.2007

**COMMISSION REGULATION (EC) No 1623/2000****of 25 July 2000****laying down detailed rules for implementing Regulation (EC) No 1493/1999 on the common organisation of the market in wine with regard to market mechanisms**

THE COMMISSION OF THE EUROPEAN COMMUNITIES,

Having regard to the Treaty establishing the European Community,

Having regard to Council Regulation (EC) No 1493/1999 on the common organisation of the market in wine<sup>(1)</sup>, and in particular Articles 24, 25, 26, 33, 34, 35, 36 and 80 thereof,

Whereas:

- (1) Title III of Regulation (EC) No 1493/1999 lays down general rules on market mechanisms and refers for the rest to detailed implementing rules to be adopted by the Commission.
- (2) Until now, those rules have been contained in a large number of Community regulations. In the interests of both economic operators in the Community and the authorities responsible for applying Community rules, all these provisions should be brought together in a single Regulation.
- (3) This Regulation must include the current rules and adapt them to the new requirements of Regulation (EC) No 1493/1999. They must also be simplified and made more coherent and certain gaps must be filled in to ensure that the Community rules in this area are complete. In addition, some rules should be made more specific to ensure greater legal certainty when they are applied.
- (4) Article 35(1)(a) of Regulation (EC) No 1493/1999 introduces an aid scheme for the use of grape must and concentrated grape must made from grapes produced in the Community for the purpose of manufacturing grape juice or other comestible products made with this juice.
- (5) Such other comestible products should be specified.
- (6) The economic aim of the aid scheme is to encourage the use of raw materials of Community origin rather than imported raw materials in the manufacture of grape juice or other comestible products made with this juice. The aid should accordingly be granted to the users of the raw materials, i.e. the processors.
- (7) It should be stipulated that the aid is granted only for raw materials with the quality characteristics required for processing into grape juice. It should accordingly be specified in particular that the grapes and grape must covered by a statement must have a density at 20 °C of between 1.055 and 1.100 grams per cubic centimetre.
- (8) Application of the aid scheme calls for an administrative system to monitor both the origin of products eligible for the aid and their intended use.
- (9) To ensure that the aid scheme and the checks operate properly, the processors concerned should be required to submit a written statement containing the information needed to enable the operations to be monitored.

<sup>(1)</sup> OJ L 179, 14.7.1999, p. 1.

**▼B**

- (10) However, to avoid excessive administration for both the processors and the authorities concerned, no prior written statement should be required from processors using only a small quantity of grapes or grape must each wine year. That quantity should be fixed. The processors concerned must nevertheless inform the competent authorities of their Member State at the beginning of each wine year of their intention to process a certain quantity of grapes or grape must.
- (11) When the processor is not the user of the product concerned, particularly where the inspecting authority concerned is in a different Member State than the processor, it is not always easy for that authority to know whether a statement relates to grape must which has not received aid under this Regulation or to grape juice for which an aid application has already been submitted. The transport document accompanying the product concerned should therefore indicate whether an aid application has been submitted.
- (12) In order for the aid scheme to significantly increase the use of Community raw materials, it should be stipulated that aid applications must be submitted for a fixed minimum quantity for each product.
- (13) Under Article 35(5) of Regulation (EC) No 1493/1999, part of the aid is to be used to organise campaigns to promote the consumption of grape juice. The percentage of the aid earmarked for this purpose should be sufficient to generate adequate funds to finance effective promotion campaigns.
- (14) Processing is carried out by both occasional processors and undertakings working continuously. The detailed rules for applying the aid scheme must take account of that difference in structures.
- (15) In order to allow the competent authorities of the Member States to conduct the necessary checks, the obligations of processors as regards stock accounts should be specified.
- (16) In order to avoid unwarranted expenditure and facilitate checks, a maximum ratio should be specified between the raw materials used and the grape juice obtained, based on normal processing techniques.
- (17) For commercial reasons, some operators store the grape juice obtained for a long time before putting it up for consumption. This being the case, a system of advances should be introduced so that the aid can be paid in advance to operators against a suitable security to protect the competent authorities against the risk of undue payment. The time limit for the payment of advances should therefore be specified, together with detailed rules for the release of securities.
- (18) To qualify for the aid, the parties concerned must submit an application together with certain supporting documents. To ensure that the system operates in the same way in all the Member States, time limits should be laid down for the submission of applications and for payment of the aid to processors.
- (19) Under Article 44(5) of Regulation (EC) No 1493/1999, grape juice may not be turned into wine or added to wine. In order to ensure compliance with that provision, the obligations and special checks devolving on processors and bottlers of grape juice should be specified.
- (20) Article 34 of Regulation (EC) No 1493/1999 introduces an aid scheme for concentrated must and rectified concentrated must produced in the Community and used to increase the alcoholic strength of wines.

**▼B**

- (21) Under Article 36 of Regulation (EC) No 1493/1999, detailed rules may be laid down, in particular to stipulate the conditions for granting the aid. On that basis, rules should be laid down for applying the measure in the case of small producers. It should also be stipulated that only producers who have fulfilled their Community obligations during a specified period are to be eligible under this measure.
- (22) The competent authorities must be informed of enrichment operations involving the addition of concentrated grape must and rectified concentrated grape must and of the quantities of those products which are held. Since the quantities of those products which are or have been used for enrichment must be recorded in the registers provided for in Article 70(2) of Regulation (EC) No 1493/1999, there is no need to require additional documents to be presented in order for the aid to be received.
- (23) To ensure uniform application of the aid scheme concerned, the method for establishing the potential alcoholic strength of musts should be harmonised at Community level.
- (24) The cost price of grape must used to produce concentrated grape must and rectified concentrated grape must depends on its potential natural alcoholic strength. To take account of this fact and to avoid disrupting the existing pattern of trade, the aid should be differentiated so that a higher amount can be granted for concentrated grape must and rectified concentrated grape must from the southernmost regions of the Community, which traditionally produce must with the highest potential natural alcoholic strength.
- (25) Article 35(1)(b) and (c) of Regulation (EC) No 1493/1999 introduces an aid scheme for the use of grape musts and concentrated grape musts produced in wine-growing zones C III (a) and C III (b) to prepare certain products falling within CN code 2206 00 in the United Kingdom and Ireland and for the use of concentrated grape musts produced in the Community to manufacture certain products marketed in the United Kingdom and in Ireland with instructions for using them to obtain a beverage in imitation of wine.
- (26) Products falling within CN code 2206 00 as referred to in Article 35(1)(c) of Regulation (EC) No 1493/1999 are currently produced exclusively from concentrated grape must. At this stage, therefore, aid should be fixed for the use of concentrated grape must alone.
- (27) Application of the aid scheme calls for an administrative system to monitor both the origin of products eligible for the aid and their intended use.
- (28) To ensure that the aid scheme and the checks operate properly, the operators concerned should be required to submit written applications giving the information needed to identify the product and enable the operations to be checked.
- (29) In order for the aid scheme to significantly increase the use of Community products, it should be stipulated that applications must be submitted for a fixed minimum quantity.
- (30) Aid is to be granted only for products having the minimum quality characteristics required for use for the purposes referred to in Article 35(1)(b) and (c) of Regulation (EC) No 1493/1999.
- (31) In order to enable the competent authorities of the Member States to conduct the necessary checks, the obligations of processors as regards stock accounts should be specified.
- (32) Entitlement to aid is acquired when the processing operations are completed. To allow for technical losses, the quantity actually

**▼B**

- used should be allowed to be up to 10 % less than the quantity stated in the application.
- (33) For technical reasons, operators lay in their stocks a long time before manufacturing the marketed products. This being the case, a system of advances should be introduced so that the aid can be paid in advance to operators against a suitable security to protect the competent authorities against the risk of undue payment. The time limit for the payment of advances should therefore be specified, together with detailed rules for the release of securities.
- (34) Under Chapter I of Title III of Regulation (EC) No 1493/1999, private storage aid may be granted for table wine, grape must, concentrated grape must and rectified concentrated grape must. opened segment Under Article 24(2) of that Regulation, the grant of aid is subject to the conclusion of storage contracts. Detailed rules should be laid down covering the conclusion, content, period of validity and effects of such contracts.
- (35) The term 'producer' should be defined and, in view of the obligations imposed upon such persons, it should be stipulated that producers must be the owners of the products covered by the storage contract.
- (36) An effective check must be kept on the products covered by storage contracts. To that end, the intervention agency of a Member State should be allowed to conclude contracts only for quantities stored on the territory of that Member State, and it should be informed of any change in the product or the place of storage.
- (37) For the sake of uniformity, contracts should be concluded on the same terms throughout the Community and be sufficiently precise to enable the product concerned to be identified.
- (38) Experience of the various schemes for the private storage of agricultural products has shown that it is necessary to specify the extent to which Council Regulation (EEC, Euratom) No 1182/71 is applicable for determining periods, dates and time limits relating to those schemes, and that the dates on which contractual storage periods begin and end should be stated precisely.
- (39) Under Article 3(4) of Regulation (EEC, Euratom) No 1182/71, where the last day of a period is a public holiday, Sunday or Saturday, the period expires at the end of the last hour of the following working day. It may not be in the interest of operators for this provision to be applied in the case of storage contracts, since it could result in unequal treatment where the last days of storage are carried over. A derogation must therefore be provided for when the final day of storage under contract is determined.
- (40) In order to ensure that the system of contracts has an effect on market prices, contracts should be concluded only for significant quantities.
- (41) Storage aid should be restricted to products which have an effect on market prices. Accordingly, only products in bulk should qualify for aid. For the same reason, contracts should cover only products of sufficiently high quality. In the case of table wine, contracts should relate to wines at an advanced stage of preparation, but it must be possible during the contract period to carry out any oenological processes needed to ensure the preservation of the product.
- (42) To encourage improvement in quality, the minimum alcoholic strength of wine and must eligible for storage measures should be fixed. To the same end, it should be possible to lay down more stringent conditions for table wine covered by storage contracts, based on the quality of the harvest.

**▼B**

- (43) In order to avoid abuse of the system, table wines which have been stored under contract may not subsequently be recognised as quality wines psr.
- (44) In order to prevent products covered by a contract from affecting the market situation, marketing and certain actions preparatory thereto should be prohibited during the contractual storage period.
- (45) Under the third indent of Article 26(1) of Regulation (EC) No 1493/1999, rules may be adopted allowing grape must covered by a long-term contract to be processed into concentrated grape must or rectified concentrated grape must during the period of validity of the contract. Since such processing is a normal operation, it should be permitted permanently.
- (46) Intervention agencies should be notified whenever grape must is processed while under a storage contract, so that they may carry out the necessary checks.
- (47) The processing of grape must into concentrated grape must and rectified concentrated grape must reduces the volume of product in storage and consequently brings down storage costs. However, since the product obtained has a higher value, the reduction in storage costs is offset by the rise in interest. It is therefore justified, in cases where the product is processed during storage, for the aid to remain at the level calculated on the basis of the quantity of grape must under contract prior to processing throughout the period of validity of the contract. Moreover, the products obtained must have the characteristics required by the Community rules.
- (48) The amount of private storage aid should take into account technical storage costs and interest. Technical storage costs can differ according to the type of product, while the amount of the interest depends on the value of the product. Accordingly, for ease of administration, the amount of aid per hectolitre per day should be fixed for separate groups of table wines and musts. Under Article 25(4) of Regulation (EC) No 1493/1999, the amount of aid for concentrated grape must should be 1,5 times higher than for grape must. However, the amounts fixed in this Regulation may be amended to take account of substantial fluctuations in market prices or interest rates.
- (49) It must also be possible to shorten the storage period in cases where the products are intended for export once removed from storage. Proof that the products have been exported should be supplied in the same way as for refunds, in accordance with Commission Regulation (EC) No 800/1999 of 15 April 1999 laying down common detailed rules for the application of the system of export refunds on agricultural products <sup>(1)</sup>.
- (50) To ensure that this system is effective while at the same time taking into account the administrative requirements of the intervention agencies, a time limit should be laid down for payment of the aid. However, in the case of long-term contracts, in order to help meet the cash-flow requirements of the producers concerned, the Member States should be authorised to introduce an advance payment scheme involving the lodging of adequate securities.
- (51) When a storage contract for table wine expires, producers may, on request, conclude a new contract using simplified formalities provided the conditions for the conclusion of a new contract for the same product are satisfied.
- (52) The market for must and concentrated must for grape juice production is expanding and, in order to promote the use of vine products for purposes other than wine-making, permission

<sup>(1)</sup> OJ L 102, 17.4.1999, p. 11.

**▼B**

should be granted for must and concentrated must covered by storage contracts and intended for grape-juice production to be sold from the fifth month of the contract onwards on simple notification by the producer to the intervention agency. This same possibility should apply to promote export of these products.

- (53) The products which may be obtained by distillation should be specified, and in particular the minimum quality requirements for neutral alcohol should be laid down. In setting these requirements, technological progress should be taken into account, as should the need to ensure that the alcohol produced can be sold normally on the markets for the different uses.
- (54) The checks on products intended for distillation should be intensified.
- (55) In the case of voluntary distillation under Articles 29 and 30 of Regulation (EC) No 1493/1999, producers should be required to conclude delivery contracts with distillers, to be approved by the intervention agency, so that operations can be supervised and both parties' compliance with their obligations can be checked. Under such a system the quantitative effects of distillation operations on the market could be more closely monitored. However, the contracts system needs to be adjusted to take account of the fact that some producers wish to entrust distillation to a jobbing distiller while others have distillation plant themselves.
- (56) Specific rules are needed to ensure that wine delivered for one of the optional distillation operations comes from the producers' own production. To that end, such producers should be required to provide proof that they have actually produced and hold the wine to be delivered. Rules are also needed to ensure that the essential elements of distillation contracts are adequately checked.
- (57) Experience shows that a certain tolerance should be allowed in the quantity and actual alcoholic strength by volume of the wine covered by delivery contracts.
- (58) Time limits should be set for payment of aid to distillers by the intervention agencies. It should also be possible for the aid to be paid to distillers in advance. A system of securities is needed to ensure that the intervention agency is not exposed to unjustified risks.
- (59) In the case of distillation under Articles 27 and 28 of Regulation (EC) No 1493/1999, experience has shown that it is not always easy for producers to calculate exactly the quantities of products they are required to deliver to meet their obligation. Where producers have delivered almost all the quantities required by the expiry of the period for delivery and have only to make some minor adjustments, the penalty imposed should not be out of proportion to the infringement committed. Such producers should therefore be deemed to have fulfilled their obligations within the time limits, provided they deliver the quantities outstanding in due course.
- (60) Distillation under Articles 27 and 28 of Regulation (EC) No 1493/1999 plays a vital role in achieving balance on the market in table wine and indirectly helps to adjust wine-growing potential to requirements. Compulsory distillation must therefore be enforced very strictly and all persons subject to the obligation to distil must actually deliver the required quantities for distillation. In some cases exclusion from intervention measures has not been a sufficient incentive to ensure that persons subject to compulsory distillation fulfil their obligations. Additional Community measures are therefore needed for producers who fail to fulfil their obligations within the time

**▼B**

- allowed but who do fulfil them before another date to be specified.
- (61) The various wine distillation operations may yield neutral alcohol as defined in the Annex to this Regulation, on the basis of criteria relating to its composition. Community methods of analysis should be adopted to ensure that these criteria are complied with.
  - (62) These methods must be compulsory for all commercial transactions and verification procedures. In view of the trade's limited facilities, a small number of usual procedures should be allowed so that the requisite factors can be determined rapidly and with reasonable accuracy.
  - (63) The Community methods of analysis should be generally recognised methods and should be uniformly applied.
  - (64) In order to ensure that the results obtained by applying the analytical methods referred to in Regulation (EC) No 1493/1999 are comparable, the terms relating to the repeatability and reproducibility of results obtained using these methods should be defined.
  - (65) The buying-in price of wine deliveries should apply ex distiller's premises. In certain cases, transport is provided by the distiller for practical reasons. In order not to disturb this practice, which is often necessary, the transport costs should be deducted from the buying-in price in such cases.
  - (66) The obligation to distil represents a considerable constraint for isolated producers who make only a small quantity of wine. The costs such producers would incur in transporting their grape marc and wine lees for distillation would be out of all proportion to the return which they could hope to obtain on the alcohol distilled from them. They should therefore be permitted not to make delivery.
  - (67) For that part of their wine production actually delivered for distillation under Article 28 of Regulation (EC) No 1493/1999, producers should be required to deliver only by-products of wine-making for distillation under Article 27 of that Regulation.
  - (68) The obligation to distil by-products is a disproportionate constraint for some producers of small quantities in certain wine-growing areas. At the request of their Member State, such producers should be allowed to have their by-products withdrawn under supervision instead of delivering them for distillation.
  - (69) Producers who deliver their marc for the manufacture of oenocyanin generally supply unfermented grape marc. The process by which oenocyanin is extracted from such marc makes the marc unsuitable for fermentation and distillation thereafter. Those producers should therefore be exempted from the obligation to distil in proportion to the quantity of grape marc they supply for such manufacture.
  - (70) When wine delivered for distillation is used to manufacture wine vinegar, the volume of alcohol delivered to intervention agencies is likely to be reduced. Producers should therefore be released from their obligation to distil where they deliver to the vinegar industry the wine which would otherwise be necessary to make up the quantity for compulsory distillation.
  - (71) Where the by-products of wine-making are withdrawn under supervision under Article 27(7) and (8) of Regulation (EC) No 1493/1999, all such by-products must have been withdrawn by the end of the wine year in which they were produced. To this end, an appropriate monitoring system is needed, which will not result in disproportionately high administrative costs, particularly in Member States whose wine production is very low.



**▼B**

- (72) Administration of the proof that marc, wine lees and wine have been delivered to a distiller should distinguish between whether the distiller is established in the same Member State as the producer or in another Member State.
- (73) Under Article 27(11) and Article 28(5) of Regulation (EC) No 1493/1999, distillers may opt either to receive aid for the product to be distilled or to deliver the product obtained by distillation to the intervention agency. The amount of aid should be fixed on the basis of the market price for the various products which may be obtained by distillation.
- (74) To qualify for the aid, the parties concerned must submit an application together with certain supporting documents. The type and number of documents required must reflect the differences between wine and wine lees on the one hand and grape marc on the other. To ensure that the system operates uniformly in all Member States, applications should be lodged and aid paid to distillers within time limits to be laid down. Some proportional allowance should be made for distillers who, although they have met their principal obligations, are late in furnishing proof thereof.
- (75) When fixing the price to be paid by the intervention agencies for the products delivered to them, account should be taken of the average cost of transporting and distilling the products concerned.
- (76) A single standard price should be fixed for products delivered to intervention agencies in connection with distillation under Article 27 of Regulation (EC) No 1493/1999, irrespective of the origin of the raw materials.
- (77) In some regions of the Community, the relation between the quantities of marc and those of wine and wine lees is such that the average distillation costs differ from those used to calculate the standard price. This situation makes it, or can make it, economically impossible in some of these regions to achieve the objective sought through the compulsory distillation of the by-products of wine-making. Prices differentiated according to the raw material of the product obtained by distillation should therefore be fixed at the same time as the standard price, while leaving it to the Member States to decide whether such differentiated prices should be applied in regions where application of the standard price would lead to the difficulties referred to above.
- (78) Recourse to this option must not increase the expenditure incurred by the intervention agency and, hence, by the EAGGF. The prices differentiated according to the origin of the alcohol should therefore be correlated with the standard price in such a way that the weighted average of the former does not exceed the standard price.
- (79) In the absence of an organised Community market in ethyl alcohol, the intervention agencies responsible for marketing the alcohol which they are obliged to take over following distillation under Articles 27 and 28 of Regulation (EC) No 1493/1999 must resell it at less than the buying-in price. The difference between the buying-in price and the selling price for such alcohol should be borne, at a standard rate, by the European Agricultural Guidance and Guarantee Fund (EAGGF) Guarantee Section.
- (80) Article 29 of Regulation (EC) No 1493/1999 provides for distillation to support the wine market and, as a consequence, to facilitate the continuation of supplies of wine distillate to parts of the potable alcohol sector. To take end-of-the-year surpluses into account, the measure should come into effect from 1 September each marketing year.
- (81) Since the Commission is responsible for organising the sale of certain wine alcohols, it needs more detailed knowledge of the

**▼B**

transactions carried out on the alcohol market. The information that the Member States send the Commission about alcohol from compulsory distillation should therefore be extended to cover alcohol from voluntary distillation held by the intervention agencies.

- (82) The required characteristics of products that may be delivered for distillation should be specified in greater detail.
- (83) Products entering distilleries should be physically checked using procedures that ensure adequate representativeness.
- (84) The consequences to be incurred by producers who fail to comply with their obligations must be specified. However, the Commission should adopt rules on the entitlement to aid of distillers who fail to comply with certain administrative time limits, in particular to take account of the proportionality principle.
- (85) Rules are needed to cover cases of *force majeure* which may prevent distillation from taking place as planned.
- (86) To ensure that distillation operations are adequately supervised, distillers should be subject to a system of approval.
- (87) To take account of the actual situation on the market in wine for distillation, both distillers and makers of fortified wine should be allowed to fortify such wine for distillation and the overall arrangements should be adjusted accordingly.
- (88) Member States should be able to restrict the places at which wine may be fortified for distillation so as to ensure the most appropriate form of supervision.
- (89) Detailed rules are needed for payment of the buying-in price for the wine, payment of aid to makers of fortified wine, payment of the aid in advance, and the lodging and release of securities.
- (90) Since the addition of an indicator to wine for distillation is an effective method of supervision, it should be stipulated that the presence of such an indicator may not prevent free movement of such wine or of products obtained therefrom.
- (91) To take account of the way in which products are transported to distilleries in some Member States, particularly where small quantities are involved, Member States should be authorised to allow them to be transported in bulk.
- (92) In the case provided for in Article 32 of Regulation (EC) No 1493/1999, for some types of distillation the buying-in price for wine should be reduced where producers have increased the alcoholic strength by adding sucrose or concentrated grape must for which they have either received or applied for aid under Article 34 of that Regulation.
- (93) It is very difficult to link the increase in alcoholic strength obtained by each producer to the wine delivered for distillation. Determining exactly the economic advantage accruing to each producer would therefore require an excessive amount of administrative work liable to delay payment of the aid and affect the whole intervention system. The buying-in price should therefore be reduced on the basis of the average increase in the natural alcoholic strength in each wine-growing zone. To avoid the excessive amount of administrative work needed to verify the increase in alcoholic strength for each producer, the buying-in price for such wine delivered for distillation should be reduced by a fixed amount for each zone or zone division.
- (94) It is only fair that producers should receive the full price if they have not increased the alcoholic strength of any part of their table wine by adding either sucrose or concentrated grape must for

**▼B**

which they have received aid under Article 34 of Regulation (EC) No 1493/1999. Moreover, producers who have increased the alcoholic strength of less of their production than they deliver for distillation should be paid the full price for the difference between the quantity enriched and the quantity delivered.

- (95) The aid for the product obtained by distillation and the price of the products taken over by the intervention agency in connection with distillation under Article 28 of Regulation (EC) No 1493/1999 must be adjusted to take account of the reduction in the buying-in price for the wine.
- (96) One feature of the Community market for alcohol is the existence of stocks resulting from intervention under Articles 27, 28 and 30 of Regulation (EC) No 1493/1999 <sup>(1)</sup>.
- (97) Specific detailed rules are needed for such tendering procedures to ensure that all purchasers are treated equally.
- (98) These stocks of alcohol may be disposed of by three different types of tendering procedure, depending on the use and destination for which the alcohol is intended and the quantities of alcohol at 100 % vol. to be disposed of.
- (99) Since the aim of tendering procedures is to obtain the most favourable price, where the Commission decides to sell following a tendering procedure the sale must be awarded to the tenderer offering the highest price. Rules are also needed for cases where several tenders for the same lot offer the same price.
- (100) Tenders for up to 5 000 hectolitres should be admissible, on certain conditions, so that new uses devised for alcohol can be tested at intermediate industrial scale, thereby helping to develop outlets in the longer term for significant quantities of Community alcohol without disrupting the market in spirit drinks.
- (101) It is necessary to determine which forms of processing into goods exported under inward processing arrangements may be considered equivalent to real industrial uses.
- (102) In order to ensure that alcohol sold under such tendering procedures is actually used for purposes not likely to disrupt the market in alcohol, tenders must give a precise indication of the intended use.
- (103) Tenderers should be allowed to submit only one tender per type of alcohol, type of end use and tendering procedure. The legal consequences for tenderers who submit more than one tender should also be specified.
- (104) In order not to affect competition with products which the alcohol may replace, the Commission should be free to award no quantities on the basis of tenders received.
- (105) So that sales can be awarded in response to the greatest possible number of tenders submitted where the proposed prices are deemed satisfactory and the proposed end uses are suitable for developing new industrial outlets for the product, it should be possible, within certain limits, for tenderers who have submitted such tenders to be awarded a replacement lot. Such a procedure is likely to increase sales of Community alcohol and thus reduce stocks which must otherwise be managed at a high cost to the budget.
- (106) Irrespective of the margin of tolerance on the overall quantity of alcohol put up for sale by tender, the price to be paid before a removal order is issued should be calculated on the basis of a

<sup>(1)</sup> Recitals 98 to 124: see the recitals of Regulation (EEC) No 377/93.

**▼B**

- quantity of alcohol at 100 % vol., determined to the nearest hectolitre.
- (107) Regular tendering procedures should be held for export of the alcohol awarded to the countries of the Caribbean area for final use in the fuel sector so as to give these countries greater continuity of supply. Experience shows that this outlet is most unlikely to disrupt the market and affords a major market opportunity.
  - (108) The size of the lots put up for sale by tender for export to the Caribbean countries should be linked to normal sea transport capacity, thereby reducing the cost to the traders concerned of providing performance guarantees. The time limits laid down for removing the alcohol awarded should be adjusted accordingly.
  - (109) Public sales of wine alcohol for use as fuel within the Community should be subject to certain conditions so as to provide undertakings with supplies to some extent and take account of the cost of the investment in processing plant needed for that particular use, without, however, preventing the alcohol put up for sale from being physically moved.
  - (110) It should be specified that public sales of this type should involve several lots of alcohol where large quantities are set aside for such public sales and that the alcohol in the vats concerned can no longer be physically moved until a removal order has been issued for it.
  - (111) In the case of sale by tender or public sale for use as fuel, since physical removal and processing of the alcohol must take place over a period of several years, the price per hectolitre of alcohol at 100 % vol. offered by the successful tenderer should be adjusted every three months by applying a coefficient indicated in the relevant notice of invitation to tender, so that the prices to be paid for the alcohol awarded more closely follow the fluctuation of fuel prices on international markets.
  - (112) In view of the size of some of the vats in which part of the alcohol obtained by compulsory distillation is stored and the considerable length of time that some of this alcohol remains in storage, it is impossible in practice to know exactly what quantity of marketable alcohol is contained in certain storage vats.
  - (113) This being the case, any tendering procedure ultimately found to relate to a quantity of marketed alcohol amounting to between 99 and 101 % of the quantity of alcohol originally put up for sale should be deemed to have been executed.
  - (114) Tenderers' statements waiving all claims in respect of the quality and characteristics of the alcohol awarded to them should not extend to hidden defects that by their nature could not be detected by them beforehand and that make the alcohol unfit for the use intended.
  - (115) Alcohol reserved for certain sales by tender should be denatured where appropriate to prevent it from being used for other purposes. The quantity of alcohol awarded in such cases should be denatured by adding petrol.
  - (116) A system of securities should be introduced to ensure that tendering procedures are properly conducted and that the alcohol is in fact used for the purpose specified in the relevant invitation to tender. Securities should be set at a level which will prevent any utilisation contrary to the objectives of the tendering procedure that might cause a disturbance on the market in alcohol and spirit drinks produced in the Community in accordance with Article 31 of Regulation (EC) No 1493/1999. The rules laid down in Commission Regulation (EEC) No 2220/85 of 22 July

**▼B**

1985 laying down common detailed rules for the application of the system of securities for agricultural products, which also covers wine, should be taken into account. The primary requirements of the obligations subject to a security should therefore be specified.

- (117) Losses may occur when alcohol is being transported by land and sea and processed prior to final use. Account should be taken of the relevant technical standards to evaluate changes in the volume of alcohol recorded on loading and unloading and a specific tolerance limit should be set for each category of loss.
- (118) An overall tolerance limit should be set for losses of alcohol due to multiple land and sea transport operations in connection with a tendering procedure for the export of alcohol to be processed in the third countries covered by this Regulation. A higher tolerance limit should also be set for alcohol losses due to processing operations in such third countries by comparison with similar operations in the Community to take account of operational, climatic and other conditions and the fact that some equipment is less efficient in some third countries.
- (119) Penalties should be applied for losses exceeding the set tolerance limits by withholding a standard amount of the performance guarantee covering the cost price of the alcohol delivered to the intervention agency in connection with distillation under Articles 27, 28 and 30 of Regulation (EC) No 1493/1999. Part of the performance guarantee should be released only after the successful tenderer has produced evidence concerning all the losses relating to the tender concerned so that the amount of guarantee available is sufficient to penalise such illegal losses of alcohol.
- (120) Some end uses intended for alcohol covered by a tendering procedure require all or some of the alcohol awarded to be processed into rectified alcohol. Some of the intended uses for the alcohol sold require prior rectification or dehydration that also produces foul-tasting alcohol unsuitable for the uses initially intended for these tendering procedures. This being the case, the conditions on which performance guarantees can be released should be amended.
- (121) The checks made to verify whether the alcohol is used for the purposes specified in the relevant invitations to tender should include at least checks equivalent to those applied to the monitoring of Community-produced alcohol. For the purposes of checks on certain uses or destinations, an international surveillance firm may be used to verify whether the contract awarded is duly fulfilled. In line with the strengthening and development of the internal market, physical checks should be conducted at the place of departure or destination of alcohol transport operations.
- (122) The measures provided for in this Regulation are in accordance with the opinion of the Management Committee for Wine,

HAS ADOPTED THIS REGULATION:

*Article 1*

**Purpose**

Title III of Regulation (EC) No 1493/1999 and this Regulation lay down the Community rules applicable to market mechanisms in the wine sector.

**▼B**

This Regulation lays down the detailed rules for applying Regulation (EC) No 1493/1999 in particular regarding aid for the use of grapes, grape must and concentrated grape must (Title I), private storage aid (Title II) and distillation (Title III).

*Article 2***General provisions**

1. Member States may rule that operators starting up their activities for the first time during a given wine year are entitled to aid under this Regulation only for products resulting from the processing of their own grape production.
2. Without prejudice to Article 30 of this Regulation, operators who were subject to the obligations laid down in Articles 27 and 28 of Regulation (EC) No 1493/1999 during the previous wine year shall be eligible for the measures provided for in this Regulation only where they provide evidence that they fulfilled their obligations regarding delivery or withdrawal under supervision during the wine year concerned.

**▼M1**

For the 2000/01 wine year, the obligations referred to in the first subparagraph shall be those laid down in Articles 35 and 36 of Regulation (EEC) No 822/87.

**▼B****TITLE I****AID FOR THE USE OF GRAPES, GRAPE MUST,  
CONCENTRATED GRAPE MUST OR RECTIFIED  
CONCENTRATED GRAPE MUST****▼M12****CHAPTER I****MANUFACTURE OF GRAPE JUICE***Article 3***Purpose of the aid**

Aid under Article 35(1)(a) of Regulation (EC) No 1493/1999 shall be granted to processors who:

- (a) being themselves producers or groups of producers, process or have processed on their behalf grapes from their own harvest and grape must and concentrated grape must obtained entirely from their own grape crop into grape juice; or
- (b) buy directly or indirectly from producers or groups of producers grapes produced in the Community and grape must and concentrated grape must for the purpose of processing them into grape juice.

The grape must and concentrated grape must used must come from grapes produced in the Community.

**▼M12***Article 4***Manufacture of other comestible products from grape juice**

The grape juice or concentrated grape juice obtained may be processed into any comestible products other than wine products as referred to in Annex I to Regulation (EC) No 1493/1999 or the products referred to in Article 35(1)(b) and (c) of that Regulation.

*Article 5***Technical requirements relating to products**

1. The raw materials for the manufacture of grape juice referred to in Article 3 must be of sound and fair merchantable quality and suitable for processing into grape juice.
2. The grape must used and the must obtained from grapes used must have a density at 20 °C of between 1,055 and 1,100 grams per cubic centimetre.
3. At the time it is used to manufacture comestible products, the grape juice must comply with Council Directive 2001/112/EC <sup>(1)</sup>.

*Article 6***Administrative rules applicable to processors for inspection purposes**

1. Processors who undertake operations for the manufacture of grape juice throughout the current wine year shall submit, before the start of each wine year, a grape juice processing schedule to the competent authority of the Member State. If the processor is undertaking operations for the manufacture of grape juice for the first time after the start of a wine year the schedule must be drawn up before operations commence.

The schedule shall contain the following information:

- (a) the type of the raw materials intended for processing (grapes, grape must or concentrated grape must);
- (b) the place where the grape must and concentrated grape must intended for processing are stored;
- (c) the place where processing is to be carried out.

2. Processors who carry out operations for the manufacture of grape juice only on specified dates shall submit, at least three working days before the operations are to start, a processing statement to the competent authority of the Member State.

The processing statement shall contain the following information:

- (a) the information required under the second subparagraph of paragraph 1;
- (b) the quantity of grapes, grape must or concentrated grape must intended for processing;

<sup>(1)</sup> OJ L 10, 12.1.2002, p. 58.

**▼M12**

- (c) the density of the grape must and concentrated grape must;
- (d) the starting date and probable duration of processing operations.

The statement must cover a minimum quantity of:

- (a) 1,3 tonnes for grapes;
- (b) 10 hectolitres for grape must;
- (c) 3 hectolitres for concentrated grape must.

3. In addition to the information referred to in paragraphs 1 and 2, Member States may ask processors to provide further information.

4. The competent authority of the Member State shall stamp the schedules and statements provided for in paragraphs 1 and 2 and return a copy to the processor.

5. As an exception to paragraphs 1, 2 and 3, Member States may introduce simplified procedures for processors who use no more than 5 tonnes of grapes or 40 hl of grape must or 12 hl of concentrated grape must each wine year.

6. Processors shall keep stock records showing the following information taken from the accompanying documents or registers referred to in Article 70 of Regulation (EC) No 1493/1999:

- (a) the quantities and the density of the raw materials entering their premises each day and, where applicable, the name and address of the seller;
- (b) the quantities and density of raw materials used each day;
- (c) the quantities of grape juice produced each day;
- (d) the quantities of grape juice leaving their premises each day and the name and address of the consignee, or the quantities of grape juice used each day by the processor.

The supporting documents relating to the stock records shall be made available to the inspection authorities on the occasion of any checks.

#### *Article 7*

##### **Administrative rules applicable to users for inspection purposes**

1. For the purposes of this Chapter, 'user' means any operator carrying out one of the following operations: bottling, packaging or presenting the grape juice or concentrated grape juice, storing with a view to sale to one or more undertakings responsible for carrying out the preceding or following operations, or preparing other comestible products from that juice.

Such operations may also be carried out by processors as referred to in Article 3.

2. Users shall submit to the competent authority of the place of unloading a written undertaking not to process the grape juice into the wine products referred to in Annex I to Regulation (EC) No 1493/1999 or the products referred to in Article 35(1)(b) and (c) of that Regulation.



**▼ M12**

The Member States shall lay down the requirements for submitting such undertakings. However, the undertaking must be submitted before the grape juice or concentrated grape juice is used, and no later than four months after the submission of the aid application referred to in Article 8 of this Regulation.

Export shall be regarded as compatible with such undertakings.

3. Where processors dispatch the grape juice to a user within the Community:

- (a) processors shall indicate on the accompanying document referred to in Article 70(1) of Regulation (EC) No 1493/1999 whether the manufacture of the grape juice has been or will be subject to an aid application from them and the actual or planned date of submission of the application;
- (b) users shall send the accompanying document to the competent authority of the place of unloading no later than 15 days after receipt of the product;
- (c) where users dispatch the juice they have received to another operator within the Community they shall ensure that that operator signs their written undertaking and shall submit it to the competent authority within the time limit set in the second subparagraph of paragraph 2;
- (d) the competent authority, after having received the written undertaking, shall stamp the accompanying document and send a copy of the stamped accompanying document to the processor of the grape juice in question no later than 30 days after receipt of the undertaking.

4. Under Article 2 of Commission Regulation (EC) No 2729/2000<sup>(1)</sup>, during the wine year the competent authorities shall check by sampling, on the basis of a risk analysis, to ensure that the undertaking referred to in paragraph 2 of this Article has been respected. The checks shall relate to at least 10 % of the quantities covered by applications for the stamping of the accompanying documents provided for in paragraph 3(d) of this Article received during the previous wine year.

*Article 8*

**Aid applications**

1. Processors as referred to in Article 6(1) shall submit aid applications to the competent authority of the Member State no later than six months after the end of the wine year. These shall be accompanied by the following documents:

- (a) a copy of the processing schedule referred to;
- (b) a copy of the stock records referred to in Article 6(6) or a summary thereof; the Member States may require such copies and summaries to be certified by an authority responsible for inspections.

Member States may require further documentation.

2. Processors as referred to in Article 6(2) shall submit aid applications to the competent authority of the Member State no later than six

<sup>(1)</sup> OJ L 316, 15.12.2000, p. 16.

**▼M12**

months after the end of the processing operations. These shall be accompanied by the following documents:

- (a) a copy of the processing statement referred to;
- (b) a copy of the stock records referred to in Article 6(6) or a summary thereof; the Member States may require such copies and summaries to be certified by an authority responsible for inspections.

Aid applications shall indicate the quantity of raw materials actually processed and the day on which the processing operations were completed.

3. The processor shall submit to the competent authority of the Member State, no later than six months after submitting the aid application:

- (a) a copy of the accompanying document stamped by the competent authority as laid down in Article 7(3)(d);
- (b) a copy of the accompanying document bearing the customs stamp certifying export.

4. As an exception to paragraphs 1 and 2, Member States may introduce simplified procedures for processors who use no more than 5 tonnes of grapes or 40 hl of grape must or 12 hl of concentrated grape must each wine year. These procedures must be completed no later than six months after the end of the wine year.

*Article 9*

**Aid amounts and rules**

1. Aid for the use of grapes, grape must and concentrated grape must shall be fixed per unit of quantity of raw material actually used as follows:

- (a) for grapes: EUR 4,952 per 100 kg;
- (b) for grape must: EUR 6,193 per hl;
- (c) for concentrated grape must: EUR 21,655 per hl.

2. Except in cases of *force majeure*, no aid shall be payable on quantities of raw materials in excess of the following ratio between the raw material and the grape juice obtained:

- (a) 1,3 for grapes, in 100 kg per hl;
- (b) 1,05 for must, in hl per hl;
- (c) 0,30 for concentrated must, in hl per hl.

Where the product obtained is concentrated grape juice, those ratios shall be multiplied by five.

▼ **M12***Article 10***Payment of the aid**

The competent authority shall pay the aid within three months of the date of presentation of the required documentation referred to in Article 8.

*Article 11***Advance payments**

1. Processors may request advance payment of an amount equal to the aid referred to in Article 9 calculated for the raw materials which they can prove have entered their premises, provided they have lodged a security with the competent authority. That security shall be 120 % of the amount of the advance.
2. Advances shall be paid by the competent authority within three months of presentation of proof that the security has been lodged. However, no advances shall be paid before 1 January of the wine year concerned.
3. After the competent authority has checked the required documentation referred to in Article 8 the security referred to in paragraph 1 of this Article shall be released in full or in part in accordance with the procedure laid down in Article 19 of Regulation (EEC) No 2220/85.

*Article 11a***Penalties and cases of *force majeure***

1. If the processor presents the required documentation referred to in Article 8 late, but within six months of expiry of the deadline referred to in that Article, the aid shall be reduced by 30 %.

If the processor presents the documentation after the six months referred to above have elapsed, no aid shall be paid.

2. If a check reveals that the user has not complied with the undertakings referred to in Article 7(2) and (3) the aid shall be recovered from the processor. If the user is domiciled in a Member State other than that where the processor is domiciled the Member State concerned shall notify the Member State where the processor is domiciled of the non-compliance without delay.
3. Except in cases of *force majeure*, if processors are found not to have complied with the obligations imposed on them under this Chapter other than the obligation to process into grape juice the raw materials covered by the aid application the aid shall be reduced. The Member State concerned shall set the rate of that reduction.
4. If the quantity of raw material actually used is between 95 % and 99,9 % of the quantity for which the advance was paid the security referred to in Article 11 shall be forfeit for the quantity not processed during the wine year.

Except in cases of *force majeure*, if the quantity of raw material actually used is less than 95 % of the quantity for which the advance was paid, the security shall be forfeit in its entirety.

**▼M12**

5. In cases of *force majeure*, the competent authority of the Member State shall determine the measures which it deems appropriate in the light of the reasons invoked and shall inform the Commission thereof.

**▼B**

## CHAPTER II

**AID FOR MUST USED TO INCREASE THE ALCOHOLIC STRENGTH OF WINE PRODUCTS***Article 12***Purpose of the aid**

1. Aid as referred to in Article 34(1) of Regulation (EC) No 1493/1999 shall be granted to producers of table wines or quality wines produced in specified regions (quality wines psr) who use concentrated grape must and rectified concentrated grape must produced in the Community to increase the natural alcoholic strength by volume of the products referred to in Annex V(C) to Regulation (EC) No 1493/1999.

2. Notwithstanding paragraph 1, in the case of quantities of ten hectolitres or less per wine year, the Member States may decide to grant the aid to producers of concentrated grape must and rectified concentrated grape must when the purchasers are individual wine-growers using the product exclusively for enriching their own production.

The Member States shall adopt detailed rules for applying this measure and notify the Commission thereof.

*Article 13***Amount of the aid**

1. The amount of the aid referred to in Article 34(1) of Regulation (EC) No 1493/1999 shall be fixed as follows, by potential alcoholic strength by volume (% vol.) per hectolitre, for the following categories of products:

(a) Concentrated grape must from grapes harvested:

- in wine-growing zones C III (a) and C III EUR 1.699/% vol./hl
- elsewhere EUR 1.466/% vol./hl

(b) Rectified concentrated grape must from grapes harvested:

- in wine-growing zones C III (a) and C III EUR 2.206/% vol./hl
- elsewhere EUR 1.955/% vol./hl

**▼M14**

However, ►M20 for wine years ►M25 2003/04 to 2007/2008 ◄ ◄ for rectified concentrated musts obtained from grapes harvested outside wine-growing zones CIII (a) and CIII (b), in establishments that began production of rectified concentrated musts before 1 January 1986 in the case of Spain, and before 30 June 1982 elsewhere, the aid shall be that specified for zone CIII products.

**▼M12**

2. The potential alcoholic strength of the products listed in paragraph 1 shall be determined by applying the figures in the table of equivalence in Annex I hereto to the readings at 20 °C from a refractometer used in accordance with the method laid down in the Annex to Commission Regulation (EC) No 558/93 <sup>(1)</sup>.

A tolerance of 0,2 shall be allowed in checks by the competent authorities.

**▼B***Article 14***Aid applications**

Producers wishing to receive the aid provided for in Article 34(1) of Regulation (EC) No 1493/1999 shall submit an application to the competent intervention agency covering all operations to increase alcoholic strength to which that Article applies. Applications must reach the intervention agency within two months of the date on which the last operation was carried out.

Applications shall be accompanied by the documents relating to the operations for which aid is requested.

**▼M12**

However, the Member States may provide for several aid applications to be submitted covering some of the operations to increase alcoholic strength.

*Article 14a***Checks**

1. The competent authorities of the Member States shall take all necessary steps to ensure the checks needed in order to verify in particular the identity and volume of the product used to increase the alcoholic strength and compliance with Annex V, points C and D, to Regulation (EC) No 1493/1999.

2. Producers shall be obliged to allow the checks referred to in paragraph 1 at any time.

**▼B***Article 15***Conditions for granting the aid**

1. Except in cases of *force majeure*, no aid shall be payable if the producer does not carry out the operation referred to in Article 34(1) of Regulation (EC) No 1493/1999 in accordance with Annex V(C) and (D) to that Regulation.

2. Except in cases of *force majeure*, where producers fail to comply with any of the requirements of this Regulation other than that referred to in paragraph 1, the aid payable shall be reduced by an amount to be fixed by the competent authority depending on the seriousness of the infringement.

<sup>(1)</sup> OJ L 58, 11.3.1993, p. 50.

**▼B**

3. In cases of *force majeure*, the competent authority shall determine the measures which it deems necessary in view of the circumstances invoked.

**▼M12***Article 16***Payment of the aid**

The competent authority shall pay the aid no later than 31 August following the end of the current wine year.

**▼B***Article 17***Advance payments**

1. From 1 January of the wine year concerned, producers may request that an amount equal to the aid calculated for the products used to increase alcoholic strength be paid to them in advance provided that they have lodged a security in favour of the intervention agency. The security shall be equal to 120 % of the aid applied for.

Applications shall be accompanied by such of the documents referred to in the second paragraph of Article 14 as are available. The remaining documents shall be submitted before the end of the wine year.

2. The intervention agency shall pay advances within three months of presentation of proof that the security has been lodged.

3. After the competent authority or the authorised department has checked all the documents, and taking account of the amount to be paid, the security shall be released in whole or in part, as the case may be, in accordance with the procedure laid down in Article 19 of Commission Regulation (EEC) No 2220/85.

## CHAPTER III

**AID FOR THE MANUFACTURE OF CERTAIN PRODUCTS IN THE UNITED KINGDOM AND IN IRELAND***Article 18***Purpose and amount of the aid**

1. Aid as referred to in Article 35(1)(b) and (c) of Regulation (EC) No 1493/1999 shall be granted:

- (a) to manufacturers who use concentrated grape must obtained entirely from grapes produced within wine-growing zones C III (a) and C III (b) for the manufacture in the United Kingdom and Ireland of products falling within CN code 2206 00 for which the use of a composite name including the word 'wine' may be allowed by these Member States under Annex VII(C)(3) to Regulation (EC) No 1493/1999, hereinafter called 'manufacturers'. The amount of the aid shall be EUR 0.2379 per kilogram;
- (b) to operators who use concentrated grape must obtained entirely from grapes produced in the Community as the main component in a set of products which they market in the United Kingdom and Ireland, with clear instructions enabling the consumer to obtain therefrom a beverage in imitation of wine, hereinafter called

**▼B**

'operators'. The amount of the aid shall be EUR 0.3103 per kilogram.

2. To be eligible for aid, concentrated grape must shall be of sound, fair and merchantable quality and suitable for use for the purposes referred to in Article 35(1)(b) or (c) of Regulation (EC) No 1493/1999.

*Article 19***Aid applications**

1. Manufacturers and operators wishing to receive aid as provided for in Article 35(1)(b) or (c) of Regulation (EC) No 1493/1999 shall submit a written application, between 1 August and 31 July of the wine year concerned, to the competent authority of the Member State in which the concentrated grape must is used.

Applications must be made at least seven working days before the manufacturing operations begin.

However, the period of seven working days may be shortened where the competent authority so authorises in writing.

2. Aid applications shall cover a minimum quantity of 50 kilograms of concentrated grape must.

3. Aid applications shall show, in particular:

(a) the name or business name and the address of the manufacturer or operator;

(b) the wine-growing zone from which the concentrated grape must originates, as defined in Annex III to Regulation (EC) No 1493/1999;

(c) the following technical information:

(i) the place of storage,

(ii) the quantity (in kilograms or, if the concentrated grape must referred to in Article 35(1)(c) of Regulation (EC) No 1493/1999 is put up in containers with contents not exceeding 5 kilograms, the number of containers),

(iii) the density,

(iv) the prices paid,

(v) the place where the operations referred to in Article 35(1)(b) and (c) of Regulation (EC) No 1493/1999 are carried out.

The Member States may require additional information for the purpose of identifying the concentrated grape must.

4. A copy of the accompanying document(s) covering transport of the concentrated grape must to the manufacturer's or operator's premises, drawn up by the competent authority of the Member State, shall be attached to the aid application.

Column 8 of the document shall indicate the wine-growing zone where the fresh grapes used were harvested.

*Article 20***Conditions for granting the aid**

1. Manufacturers and operators shall be bound to use the full quantity of concentrated grape must covered by an aid application for the purposes referred to in Article 35(1)(b) and (c) of Regulation (EC) No 1493/1999. A shortfall of 10 % of the quantity of concentrated grape must stated in the application shall be tolerated.
2. Manufacturers and operators shall keep stock accounts showing in particular:
  - (a) the consignments of concentrated grape must purchased and brought each day into their premises, together with the information indicated in Article 19(2)(b) and (c) of this Regulation and the name and address of the seller(s),
  - (b) the quantities of concentrated grape must used each day for the purposes referred to in Article 35(1)(b) and (c) of Regulation (EC) No 1493/1999,
  - (c) the consignments of finished products mentioned in Article 35(1)(b) and (c) of Regulation (EC) No 1493/1999 produced and dispatched each day from their premises, together with the name and address of the consignee(s).
3. Manufacturers and operators shall inform the competent authority in writing, within one month, of the date when all the concentrated grape must covered by an aid application has been used for the purposes referred to in Article 35(1)(b) and (c) of Regulation (EC) No 1493/1999, allowing for the shortfall provided for in paragraph 1 of this Article.
4. Except in cases of *force majeure*, no aid shall be payable where manufacturers or operators fail to fulfil the requirement set out in paragraph 1 of this Article.
5. Except in cases of *force majeure*, where manufacturers or operators fail to comply with any of the requirements of this Regulation other than that referred to in paragraph 1 of this Article, the aid payable shall be reduced by an amount to be fixed by the competent authority depending on the seriousness of the infringement.
6. In cases of *force majeure*, the competent authority shall determine the measures which it deems necessary in view of the circumstances invoked.

*Article 21***Payment of the aid**

The competent authority shall pay aid for the quantity of concentrated grape must actually used not later than three months after receiving the information referred to in Article 20(3) of this Regulation.

*Article 22***Advance payments**

1. Manufacturers and operators as referred to in Article 18 of this Regulation may apply for an amount equal to the aid to be paid in



**▼B**

advance provided they have lodged a security for 120 % of the said amount in favour of the competent authority.

2. Advance payments as referred to in paragraph 1 shall be paid within three months of presentation of proof that the security has been lodged, provided that evidence is supplied that the concentrated grape must has been paid for.

3. After the competent authority has received the information referred to in Article 20(3) of this Regulation, and taking account of the amount of aid to be paid, the security referred to in paragraph 1 shall be released in whole or in part, as the case may be, in accordance with the procedure laid down in Article 19 of Commission Regulation (EEC) No 2220/85.

## **TITLE II PRIVATE STORAGE AID**

### *Article 23*

#### **Purpose**

This Title lays down the detailed rules for applying the storage aid scheme referred to in Chapter I of Title III of Regulation (EC) No 1493/1999.

### *Article 24*

#### **Definitions**

For the purposes of this Title, 'products' means grape must, concentrated grape must, rectified concentrated grape must and table wines, irrespective of the wine year in which they were produced.

### *Article 25*

#### **Amount of the aid**

Storage aid shall be payable throughout the Community at the following standard rates per hectolitre per day:

- (a) EUR 0.01837 for grape must;
- (b) EUR 0.06152 for concentrated grape must;
- (c) EUR 0.06152 for rectified concentrated grape must;
- (d) EUR 0.01544 for table wines.

### *Article 26*

#### **Rules applicable to beneficiaries**

1. Intervention agencies shall conclude private storage contracts only with producers.

**▼B**

For the purposes of this Title, ‘producer’ means any natural or legal person or group of such persons which carries out, or has carried out on their behalf, any of the following operations:

- (a) the processing of fresh grapes into grape must,
- (b) the processing of grape must into concentrated grape must or rectified concentrated grape must,
- (c) the processing of fresh grapes, grape must or grape must in fermentation into table wine.

The organisations referred to in Article 39 of Regulation (EC) No 1493/1999 shall be treated as producers for the quantities obtained by their members. The individual members delivering wine covered by a private storage contract shall be responsible for fulfilling the obligations referred to in Article 2 of this Regulation.

2. Producers may conclude contracts only for products:

- produced by them, or
- produced on their responsibility and which they own, or
- in the case of producer organisations as referred to in the third subparagraph of paragraph 1, produced on the responsibility of their members.

3. The intervention agency of a Member State may conclude contracts only for products stored on the territory of that Member State.

**▼M23****▼B***Article 27***Characteristics of products eligible for aid**

When contracts are concluded:

- (a) the grape musts concerned must have been obtained exclusively from varieties classified as wine grapes in accordance with Article 19 of Regulation (EC) No 1493/1999 and may not have a natural alcoholic strength by volume lower than the minimum natural alcoholic strength laid down for the wine-growing zone in which they originate,
- (b) table wines:
  - (i) must comply with the minimum quality requirements fixed in Annex II to this Regulation for the category for which the contract is concluded;
  - (ii) must have a reducing sugar content not greater than two grams per litre, except in the case of table wines from Portugal, which must have a reducing sugar content not greater than four grams per litre;
  - (iii) must display a satisfactory 24-hour exposure to air,
  - (iv) must be free of bad tastes.

**▼B**

- (c) The radioactivity levels of the products referred to in Article 24 of this Regulation may not exceed the maximum levels permitted under Community rules. However, the level of radioactive contamination of products shall be monitored only if the situation so requires and only during the period necessary.

*Article 28***Quantities eligible for aid**

1. The total quantity of products for which producers conclude storage contracts may not exceed the quantity stated in their production declaration for the wine year concerned, submitted in accordance with Article 18(1) of Regulation (EC) No 1493/1999, plus any quantities they obtained after the date on which their declaration was submitted and recorded in the registers referred to in Article 70 of Regulation (EC) No 1493/1999.
2. Contracts shall cover a minimum quantity of 50 hectolitres in the case of table wine, 30 hectolitres in the case of grape must and 10 hectolitres in the case of concentrated grape must and rectified concentrated grape must.

*Article 29***Conclusion of contracts**

1. Producers may conclude contracts provided they supply the following information for each container in which the product concerned is stored:
  - (a) details enabling the product to be identified,
  - (b) the following analysis data:
    - (i) the colour,
    - (ii) the sulphur dioxide content,
    - (iii) the absence of hybrids, in the case of red products, as demonstrated by analysis for malvidol diglucoside.

For grape must, concentrated grape must and rectified concentrated grape must, the following information shall also be provided:

**▼M12**

- (c) the reading obtained at a temperature of 20 °C with a refractometer used in accordance with the method referred to in the Annex to Regulation (EEC) No 558/93. A tolerance shall be permitted of 0,5 for grape must and 1 for concentrated grape must and rectified concentrated grape must.

**▼B**

For table wine, the following analysis data shall also be provided:

- (d) the total alcoholic strength by volume,
- (e) the actual alcoholic strength by volume,

**▼B**

- (f) the total acidity, expressed in grams of tartaric acid per litre or in milliequivalents per litre; however, Member States may waive this requirement for white wines,
- (g) the volatile acid content, expressed in grams of acetic acid per litre or in milliequivalents per litre; however, Member States may waive this requirement for white wines,
- (h) the reducing sugar content,
- (i) behaviour in air over 24 hours,
- (j) the absence of bad tastes.

The above analysis data shall be established by an official laboratory as referred to in Article 72 of Regulation (EC) No 1493/1999 within 30 days before the contract is concluded.

2. The Member States may limit the number of contracts that a producer can sign each wine year.
3. Contracts for table wines may not be concluded before the date of the first racking of the wine concerned.
4. Producers wishing to conclude storage contracts for table wines shall, when submitting their applications, advise the intervention agency of the total quantity of table wine they have produced during the current wine year.

To that end, they shall submit a copy of the production declaration(s) provided for in Article 18(2) of Regulation (EC) No 1493/1999 and, where applicable, of the registers referred to in Article 29 of this Regulation. In cases where the declaration is not yet available, a provisional attestation may be produced.

5. Without prejudice to Article 25(2) of Regulation (EC) No 1493/1999, contracts shall contain at least:

- (a) the name and address of the producers concerned,
- (b) the name and address of the intervention agency,
- (c) the type of product, classified as indicated in Article 25 of this Regulation,
- (d) the quantity,
- (e) the place of storage,
- (f) the first day of the storage period,
- (g) the amount of aid in euros.

For table wine, contracts shall also include:

- (h) a statement that the first racking has taken place,
- (i) a clause to the effect that the volume may be reduced by a percentage to be determined by the Commission in accordance with the procedure laid down in Article 75 of Regulation (EC) No 1493/1999 should the total volume covered by contracts significantly exceed the average volumes covered in the last three wine

**▼B**

years; such reduction may not reduce the quantities in storage below the minimum levels referred to in Article 28(2). Where this clause is applied, the full amount of the aid due for the period prior to the reduction shall remain payable.

6. The Member States may require further information with a view to identifying the product concerned.

*Article 30***Derogation from Article 2 of this Regulation**

The Member States may authorise the conclusion of contracts before producers have supplied the evidence referred to in Article 2 of this Regulation provided such contracts include a statement by producers certifying that they have met the obligations referred to in that Article or fulfil the requirement referred to in Article 58 of Title III of this Regulation and that they undertake to deliver the remaining quantities needed to comply fully with their obligations within the time limit laid down by the competent national authority.

The evidence referred to in the first paragraph shall be supplied before 31 August of the wine year concerned.

*Article 31***Beginning of the storage period**

1. The first day of the storage period shall be the day following the date on which the contract is concluded.
2. However, if a contract relates to a storage period beginning after the day following that on which it is concluded, the first day of the storage period may not be later than 16 February.

*Article 32***End of the storage period**

1. Storage contracts for grape musts, concentrated grape musts and rectified concentrated grape musts shall expire between 1 August and 30 November following the date of conclusion.
2. Storage contracts for table wines shall expire between 1 September and 30 November following the date of conclusion.
3. To determine the expiry date, producers shall send the intervention agency a statement specifying the last day of validity of the contract. The Member States shall lay down the requirements for presenting these statements.

In the absence of a statement, contracts shall expire on 30 November.

4. Producers who have not applied for an advance under Article 38 of this Regulation may sell the grape must or concentrated grape must for exportation or manufacture of grape juice from the first day of the fifth month of storage.

In such cases, producers shall inform the intervention agency in accordance with paragraph 3.

**▼B**

The intervention agencies shall ensure that the products are actually used for the purpose stated.

*Article 33***Early termination of the contract at the request of the producer**

1. Producers who have not applied for an advance under Article 38 of this Regulation may terminate storage contracts as of 1 June provided the Commission so authorises in the light of market trends, information on stocks and harvest forecasts.

2. In addition, where the Commission decides to reduce the quantities covered by contracts in accordance with Article 29(5)(i) of this Regulation, producers may unilaterally terminate their contract wholly or in part in the month following the publication of that decision.

*Article 34***Detailed implementing rules relating to storage**

1. Throughout the storage period and until the last day of validity of the contract, products in storage:

- (a) must comply with the relevant definitions in Annex I to Regulation (EC) No 1493/1999,
- (b) must retain at least the minimum alcoholic strength required for the category of table wine concerned at the time of conclusion of the contract,
- (c) may not be kept in containers of less than 50 litres capacity,
- (d) must remain in bulk, and
- (e) in the case of wine, must remain fit for offer or supply for direct human consumption at the end of the storage period.

**▼M12**

2. Without prejudice to paragraph 6, products under contract may undergo only such oenological treatments and processes as are necessary for their preservation. A variation shall be permitted in the volume entered in the contract which may not exceed 2 % for wine and 3 % for grape must, concentrated grape must and rectified concentrated grape must. When there has been a change of vat, the variation permitted is set at 3 % to 4 % respectively.

**▼M17**

3. Without prejudice to Article 33 of this Regulation and paragraphs 4, 5 and 6 of this Article, producers may not market or ship to a third party the product under contract during the period of validity of a storage contract.

Notwithstanding the first subparagraph, producers may, while a storage contract is still valid, conclude a sales contract for the product in storage to take effect on expiry of the storage contract. They may also undertake to send the wine for distillation under Title III of this Regulation on expiry of the storage contract.

**▼B**

4. Producers shall inform the intervention agency in advance, within a period to be laid down by the Member State concerned, of any change during the contract period:

**▼B**

- (a) in the place of storage, or
- (b) in the manner in which the product is put up. In such cases, they shall indicate the containers in which the product is to be definitively stored.

5. Where producers intend to transport the product under contract to a place of storage located elsewhere or to premises not belonging to them, the product may be transported only once the intervention agency, informed pursuant to paragraph 4, has authorised it.

6. Producers who have concluded private storage contracts for grape must may process all or part of that must into concentrated grape must or rectified concentrated grape must during the period of validity of their contract.

Producers who have concluded private storage contracts for concentrated grape must may process all or part of that must into rectified concentrated grape must during the period of validity of their contract.

Producers may have the processing operations referred to in the previous two subparagraphs carried out by a third party provided that the said producers own the products obtained after processing and that they have presented a prior declaration. The Member State concerned shall check these operations.

7. The producers concerned shall inform the intervention agency in writing of the date when the processing referred to in paragraph 6 of this Article is to commence, the place of storage and how the product is put up.

Such notification must reach the intervention agency at least 15 days before the date of commencement of the processing operations.

Within one month of the day of completion of the processing operations, producers shall send the intervention agency an analysis report concerning the product thus obtained, including as a minimum the data required for the product concerned under Article 29 of this Regulation.

8. Where the processing referred to in paragraph 6 is carried out, the amount of storage aid for the product under contract shall be equal to:

- (a) the amount referred to in Article 25(a) of this Regulation for the processing referred to in the first subparagraph of paragraph 6,
- (b) the amount referred to in Article 25(b) of this Regulation for the processing referred to in the second subparagraph of paragraph 6.

The aid shall be calculated, for the entire storage period, on the basis of the quantity of product covered by the contract before processing.

*Article 35***Changes in the product during storage**

1. Should all or part of the product under contract cease to satisfy the requirements of Article 34(1) of this Regulation during the period of validity of the contract, the producer shall inform the intervention agency without delay. Such notification shall be supported by an analysis report. The intervention agency shall terminate the contract

**▼ B**

for the quantity concerned with effect from the date of the analysis report.

2. Should a check carried out by the intervention agency or any other inspecting agency reveal that all or part of the product under contract has ceased to satisfy the conditions laid down in Article 34(1) of this Regulation during the period of validity of the contract, the intervention agency shall terminate the contract for the quantity concerned on the date that it determines.

**▼ M12***Article 35a***Checks**

1. The competent authorities of the Member States shall take any measures required to ensure the checks necessary to verify the identity and volume of the product covered by the contract and compliance with Article 34.

2. Producers shall be obliged to allow the checks referred to in paragraph 1 at any time.

**▼ B***Article 36***Conditions for granting the aid**

1. Except in cases of *force majeure*,
  - (a) where producers fail to fulfil their obligations under Article 34(1) to (5) and (7) of this Regulation or refuse to submit to checks, no aid shall be payable;
  - (b) where producers fail to fulfil one of their obligations under this Regulation or under the contract, other than those referred to in (a) above, the aid shall be reduced by an amount determined by the competent authority depending on the seriousness of the infringement.
2. In cases where *force majeure* is recognised, the intervention agency shall take such action as it considers necessary having regard to the circumstances involved.

**▼ M12***Article 37***Payment of the aid**

1. The competent authority shall pay the aid no later than three months after the expiry date of the storage contract.
2. In cases where a contract has been terminated in accordance with Articles 33 or 35, the aid payable shall be in proportion to the actual duration of the contract. The competent authority shall pay the aid no later than three months after the day on which the contract is terminated.



**▼M12***Article 38***Advance payments**

1. Producers may request that an advance be paid to them provided that they have lodged a security for 120 % of the advance in favour of the intervention agency. Without prejudice to Article 32, the amount of the advance shall be calculated on the basis of the amount of the aid for the product in question, as referred to in Article 25.
2. Advances shall be paid by the competent authority within three months of presentation of proof that the security has been lodged.
3. Once the aid is paid by the competent authority, the security referred to in paragraph 1 shall be released.

Where entitlement to the aid is lost in accordance with Article 36(1)(a), the whole security shall be forfeit.

Where the application of Article 36(1)(b) results in an aid amount that is lower than the sum already paid, the security shall be reduced by 120 % of the amount paid in excess of the aid due. Securities reduced in this way shall be released not later than three months after the date of expiry of the contract.

The Member States shall make the necessary adjustments where the clause provided for in Article 29(5)(i) is applied.

**▼B***Article 39***Quality wines**

A table wine which has been the subject of a storage contract may not subsequently be recognised as a quality wine psr or used in making a quality wine psr, a quality sparkling wine psr, a quality liqueur wine psr or a quality semi-sparkling wine psr as defined in Article 54(1) of Regulation (EC) No 1493/1999.

**TITLE III****DISTILLATION****Introduction***Article 40***Purpose**

This Title lays down the detailed rules applicable to distillation as referred to in Chapter II of Title III of Regulation (EC) No 1493/1999.

*Article 41***Definitions**

1. For the purposes of this Title:
  - (a) 'producer' means:

**▼B**

- (i) for the purposes of Chapter I of this Title: any natural or legal person or group of such persons having produced wine from fresh grapes, grape must or partially fermented grape must or from new wine still in fermentation, obtained personally or purchased, or any natural or legal person or group of such persons subject to the obligations referred to in Article 27 of Regulation (EC) No 1493/1999;
  - (ii) for the purposes of Chapters II and III of this Title: any natural or legal person or group of such persons having produced wine from fresh grapes, grape must or partially fermented grape must, obtained personally or purchased;
- (b) ‘distiller’ means any natural or legal person or group of such persons:
- (i) distilling wine, wine fortified for distillation or the by-products of wine-making or of any other form of processing grapes, and
  - (ii) approved by the competent authorities in the Member State in whose territory the distillation premises are located;
- (c) ‘maker of wine fortified for distillation’ means any natural or legal person or group of such persons, other than distillers:
- (i) processing wine into wine fortified for distillation, and
  - (ii) approved by the competent authorities in the Member State in whose territory the premises are located;
- (d) ‘competent intervention agency’ means:
- (i) for the purposes of receiving and approving contracts or declarations relating to the delivery of wine for distillation and receiving and approving contracts relating to the delivery of wine for fortification, the intervention agency designated by the Member State in whose territory the wine is located at the time when the contract or declaration is submitted,
  - (ii) for the purposes of paying aid to makers of wine fortified for distillation under Article 69, the intervention agency designated by the Member State in whose territory the wine is fortified,
  - (iii) in all other cases, the intervention agency designated by the Member State in whose territory distillation takes place.
2. For the purposes of this Title, natural or legal persons or groups of such persons other than makers of wine fortified for distillation shall be deemed to be distillers if they:
- (a) are approved by the competent authorities in the Member State in which they are established;
  - (b) buy from a producer as defined in paragraph 1(a) wine or the by-products of wine-making or of any other form of processing of grapes with a view to having them distilled on their own account by an approved distiller, and
  - (c) pay the producer not less for the products purchased than the minimum buying-in price for the distilled product in question.

Persons or groups deemed to be distillers shall be subject to the same obligations and enjoy the same rights as distillers.

**▼B**

3. Member States may stipulate, in accordance with rules which they determine, that for the purposes of concluding contracts and delivering wine for distillation, associations of wine-growers' cooperatives may on request be deemed to be producers for those quantities of wine produced and handed over by member cooperatives. The latter shall in any case continue to hold the rights and be bound by the obligations laid down in Community rules.

Should an association intend to carry out a distillation operation under this Title in agreement with the wine-growers' cooperatives concerned during a specified wine year, it shall inform the intervention agency thereof in writing. In such cases:

- (a) member cooperatives may not individually sign distillation contracts or make deliveries for the distillation concerned,
- (b) the quantities of wine delivered for distillation by the said association shall be booked to the member cooperatives on whose behalf the delivery is made.

For the purposes of Article 2 of this Regulation, should one or more member cooperatives fail to comply with the obligations laid down therein, irrespective of the consequences for the latter, the association shall be excluded from deliveries for the distillation concerned, up to the limit of the quantities of wine delivered on behalf of the wine-growers' cooperatives which committed the infringement.

Member States availing themselves of the option provided for in this paragraph shall inform the Commission thereof and shall notify it of the provisions they have adopted for this purpose. The Commission shall inform the other Member States.

**▼M17***Article 42***Approval of distillers**

1. Member States shall approve distillers established in their territory who so request.
2. Member States may withdraw approval, either temporarily or permanently, from distillers failing to meet their obligations under this Regulation.
3. Member States shall draw up a list of the approved distillers, which they shall forward to the Commission electronically. They shall also immediately forward all subsequent amendments to that list.

The Commission shall publish that information on its website.

**▼B***Article 43***Alcohol obtained by distillation**

Only the following products may be obtained by distillation under this Title:

- (a) neutral alcohol complying with the definition in Annex III to this Regulation, or

**▼B**

- (b) spirits distilled from wine or from grape marc, complying with the definitions in Article 1(4)(d) or (f) of Council Regulation (EEC) No 1576/89 of 29 May 1989 laying down general rules on the definition, description and presentation of spirit drinks <sup>(1)</sup>, or
- (c) a distillate or raw alcohol with an alcoholic strength of at least 52 % by volume.

Where the product specified in point (c) in the first subparagraph is obtained, it may be used only under official supervision for:

- (i) the production of an alcoholic beverage,
- (ii) processing into one of the products referred to in (a) or (b) above, with the exception of spirits distilled from grape marc,
- (iii) the production of alcohol for industrial purposes.

**▼M12**

For the purposes of the distillation operations referred to in this Title, Member States shall take the necessary steps to ensure compliance with the obligation laid down in the second subparagraph.

**▼B***Article 44***Analysis method for neutral alcohol**

Annex V to this Regulation sets out the Community methods for the analysis of neutral alcohol as defined in Annex IV hereto.

## CHAPTER I

**COMPULSORY DISTILLATION***Section I: Distillation of by-products of wine-making**Article 45***Obligation to deliver by-products for distillation**

1. Producers required to distil under Article 27 of Regulation (EC) No 1493/1999 shall discharge their obligations by delivering for distillation, not later than 15 July of the wine year concerned:

- (a) all of their marc and wine lees to an approved distiller, and
- (b) where applicable, any wine to an approved distiller or approved maker of wine fortified for distillation.

**▼M12**

The Member States may stipulate that this delivery must take place before the date referred to in the first subparagraph.

<sup>(1)</sup> OJ L 160, 27.6.1989, p. 1. Last amended by Regulation (EC) No 3378/94 (OJ L 366, 31.12.1994, p. 1).

**▼ B**

Where producers make deliveries to a distiller whose approval has been withdrawn, the quantities supplied may be counted but there shall be no entitlement to Community assistance.

**▼ M26**

As an exception to the first subparagraph, for the 2004/2005, 2005/2006 and 2006/2007 wine years the date referred to therein shall be postponed to 31 August of the following wine year.

**▼ M12**

\_\_\_\_\_

**▼ B***Article 46***Requirements for by-products delivered for distillation**

1. Notwithstanding Article 27(4) of Regulation (EC) No 1493/1999, the amount of alcohol contained in products delivered for distillation by producers delivering marc for the manufacture of oenocyanin shall be at least 5 % of the amount of alcohol contained in the wine; or at least 7 % for white quality wines psr.

2. For the purpose of determining the amount of alcohol to be delivered for distillation in the form of the products specified in Article 48 of this Regulation, the standard natural alcoholic strengths by volume to be applied in the different wine-growing zones shall be:

- (a) 8.5 % for zone B,
- (b) 9.0 % for zone C I,
- (c) 9.5 % for zone C II,
- (d) 10.0 % for zone C III,

3. To keep distillation costs within acceptable limits, the minimum average requirements that wine-making by-products must meet on delivery to the distillery shall be the following:

(a) grape marc:

- (i) in wine-growing zone B: two litres of pure alcohol/100 kilograms,

**▼ M12**

- (ii) in wine-growing zone C: two litres of pure alcohol, by actual or potential strength/100 kilograms where it is obtained from varieties listed in the classification of vine varieties for the administrative unit concerned as varieties other than wine-grape varieties; litres of pure alcohol, by actual or potential strength/100 kilograms where it is obtained from varieties listed in the classification for the administrative unit concerned solely as wine-grape varieties;

**▼ B**

(b) wine lees:

- (i) in wine-growing zone B: three litres of pure alcohol/100 kilograms, 45 % moisture content,
- (ii) in wine-growing zone C: four litres of pure alcohol/100 kilograms, 45 % moisture content,

**▼B**

4. In the case of producers who deliver wine of their own production to the vinegar industry, the amount of alcohol, expressed as pure alcohol, contained in the wine delivered shall be deducted from the amount of alcohol, expressed as pure alcohol, contained in the wine to be delivered for distillation to discharge the obligation referred to in Article 27(3) of Regulation (EC) No 1493/1999.

**▼M3**

In the case of producers who deliver wine and by-products of their own production for supervised experiments conducted by the Member States, the provisions referred to in Articles 45, 46 and 47 shall apply and aid shall be paid to the person authorised to conduct the experiment at a rate of EUR 0,277/% vol/hl.

**▼B**

In the case of experiments, the Member State may not exceed 100 tonnes of marc and 100 tonnes of wine lees per experiment.

*Article 47***Buying-in price**

1. The buying-in price referred to in Article 27(9) of Regulation (EC) No 1493/1999 shall apply to bulk merchandise ex distiller's premises.

2. Distillers shall pay the buying-in price as referred to in paragraph 1 to producers within three months of the day on which the quantity concerned is delivered to the distillery.

However, unless the producer objects, distillers may:

- (a) pay the producer on account 80 % of the buying-in price, no more than three months after delivery of the products, or
- (b) make the payment on account referred in (a) following delivery of the products and no later than one month after presentation of the invoice to be drawn up for them before 31 August following the close of the wine year concerned.

Distillers shall pay the balance to producers no later than the following 31 October.

**▼M12***Article 48***Aid to be paid to distillers**

1. The aid referred to in Article 27(11)(a) of Regulation (EC) No 1493/1999 shall be fixed, per % vol. of alcohol and per hectolitre of product obtained by distillation, as follows:

- (a) for neutral alcohol:
  - obtained from marc: EUR 0,8453,
  - obtained from wine and wine lees: EUR 0,4106;
- (b) for spirits distilled from marc and distillates or raw alcohol obtained from marc having an alcoholic strength of at least 52 % vol.: EUR 0,3985;

**▼ M12**

- (c) for wine spirits and raw alcohol obtained from wine and wine lees:  
EUR 0,2777.

Where the distiller provides evidence that the distillate or raw alcohol obtained by distillation of marc was used otherwise than as spirits distilled from marc, a further amount of EUR 0,3139/% vol./hl shall be paid.

2. No aid shall be due for quantities of wine delivered for distillation exceeding the producer's obligation as provided for in Article 45 by more than 2 %.

**▼ B***Article 49***Exceptions to the obligation to deliver for distillation**

1. The obligations laid down in Article 27 of Regulation (EC) No 1493/1999 shall not apply to:

- (a) producers who withdraw by-products of wine-making under supervision under Article 50(1) of this Regulation,
- (b) producers of quality sparkling wines of the aromatic type and quality sparkling wines and semi-sparkling wines of the aromatic type produced in specified regions who have prepared such wines from grape must or partially fermented grape must which has been purchased and stabilised to eliminate the wine lees.

**▼ M12**

2. Producers who, during the wine year in question, do not produce more than 25 hectolitres of wine or must themselves on their own premises shall be free not to deliver any quantities.

**▼ B**

3. For that part of their wine production actually delivered to a distillery for distillation under Article 28 of Regulation (EC) No 1493/1999, producers shall be required to deliver only by-products of wine-making for distillation under Article 27(3) of that Regulation.

**▼ M17**

4. Under Article 27(8) of Regulation (EC) No 1493/1999, Member States may provide, in respect of all or part of their territory, that the following producers may discharge their obligation to deliver the by-products referred to in paragraphs 3 and 6 of that Article by withdrawing those products under supervision:

- (a) producers who produce no more than 80 hl by themselves on their own premises;
- (b) producers who grow their grapes using organic production methods.

**▼ B***Article 50***Withdrawals**

1. Only the following producers may avail themselves of the option referred to in Article 27(8) of Regulation (EC) No 1493/1999:

**▼B**

- (a) those established in production areas where distillation is a disproportionate constraint. A list of the production areas concerned shall be drawn up by the competent authorities of the Member States, who shall inform the Commission thereof;
- (b) those who have not made wine or processed grapes in any other way on cooperative premises and who have disproportionate distillation costs on account of their low volume of production or the special characteristics of production and the location of the distilleries.

**▼M17**

The Member State shall lay down the detailed rules of application for this point and inform the Commission thereof.

**▼B**

2. For the purposes of Article 27(7) and (8) of Regulation (EC) No 1493/1999, the by-products shall be withdrawn without delay and no later than the end of the wine year in which they were obtained. Withdrawal, together with an indication of the estimated quantities, shall be either entered in the registers kept in accordance with Article 70 of Regulation (EC) No 1493/1999 or certified by the competent authority.

The withdrawal of the wine lees in question shall be regarded as having taken place once the lees have been denatured to make their use in winemaking impossible and where the delivery of the denatured lees to third parties has been entered in the registers referred to in the first subparagraph. The Member States shall take the measures necessary to ensure that such transactions are checked.

Member States whose wine production exceeds 25 000 hectolitres per year shall check by sampling at least whether the average minimum alcoholic strength referred to in Article 51 has been complied with and whether all the by-products have been withdrawn within the time limits set.

*Article 51*

**Requirements for by-products withdrawn**

The minimum pure alcoholic strength of the by-products of wine-making withdrawn under supervision under Article 27(7) and (8) of Regulation (EC) No 1493/1999 shall be as follows:

- (a) grape marc:
  - (i) 2.1 litres/100 kilograms in the case of quality white wines psr,
  - (ii) 3 litres/100 kilograms in other cases.
- (b) wine lees:
  - (i) 3.5 litres/100 kilograms in the case of quality white wines psr,
  - (ii) 5 litres/100 kilograms in other cases.



**▼ B*****Section II: Distillation of wine from dual-purpose grapes*****▼ M9***Article 52***Determination of quantity normally produced**

1. In the case of wine obtained from grapes of varieties classified as both wine-grape varieties and varieties for other uses as referred to in Article 28 of Regulation (EC) No 1493/1999, the total quantity normally produced shall be determined for each region concerned.

The total quantity normally produced shall comprise:

- wine products intended for the production of table wine and wine suitable for yielding table wine,
- must intended for the production of concentrated must and rectified concentrated must for the purposes of enrichment,
- must intended for the production of liqueur wines with a designation of origin,
- wine products for the production of spirits distilled from wine with a designation of origin.

The reference period shall cover the following wine years:

- 1974/75 to 1979/80 in the Community of Ten,
- 1978/79 to 1983/84 in Spain and Portugal,
- 1988/89 to 1993/94 in Austria,

**▼ M16**

- 1997/98 to 2002/03 in the Czech Republic, Cyprus, Hungary, Malta, Slovenia and Slovakia,

**▼ M24**

- 1999/2000 to 2004/2005 in Romania.

**▼ M14**

However, in the case of wine obtained from grapes of varieties classified as both wine-grape varieties and varieties for the production of spirits distilled from wine with a designation of origin, the total quantity normally produced in the region during that reference period shall be reduced by the quantities that were the subject of distillation other than to produce spirits distilled from wine with a designation of origin in that period. Moreover, where the quantity normally produced in the region is over 5 million hl, this total quantity normally produced shall be reduced by 1,4 million hl ► **M20** for wine years ► **M25** 2001/02 to 2007/08. ◀ ◀

**▼ M9**

2. In the regions referred to in paragraph 1, the quantity normally produced per hectare shall be set by the Member States concerned by determining for the same reference period referred to in that paragraph the portion of wine obtained from grapes of varieties classified in the same administrative unit as both wine-grape varieties and varieties for other uses.

From the 1998/1999 wine year, as regards wine obtained from grapes of varieties classified in the same administrative unit as both wine-grape varieties and varieties for the production of spirits from wine with a designation of origin, the Member States shall be authorised to allow

**▼M9**

producers who have received premiums from the 1997/98 wine year for the permanent abandonment of part of their vine-growing areas as provided for in Article 8 of Regulation (EC) No 1493/1999 to maintain, for the five wine years following grubbing, the quantity normally produced at the level it stood at before grubbing.

*Article 53***Determination of the quantity of wine to be distilled**

1. All producers subject to the distillation obligation under Article 28 of Regulation (EC) No 1493/1999 shall have distilled the total quantity of their production intended for wine-making less their quantity normally produced as defined in Article 52(2) and their quantity of exports out of the Community during the wine year in question.

In addition, producers may deduct from the quantity to be distilled resulting from that calculation a maximum quantity of 10 hl.

2. Where the quantity normally produced is greater than 5 million hl, the total quantity of wine to be distilled under Article 28 of Regulation (EC) No 1493/1999 shall be determined by the Member State for each region concerned. It shall comprise the total quantity intended for wine-making less the total quantity normally produced as defined in Article 52 and the quantity of wine exported from the Community in the wine year in question.

In those regions:

- the Member State shall apportion the total quantity of wine to be distilled in the region concerned among the individual wine producers in that region in accordance with objective criteria and without discrimination and shall inform the Commission thereof,
- distillation shall be authorised only if the total quantity intended for wine-making in the region in the wine year concerned exceeds the total quantity normally produced in the region concerned,
- for each wine year a difference of 200 000 hectolitres shall be allowed between the regional quantity to be distilled and the aggregate individual quantities.

*Article 54***Dates of delivery of wine for distillation**

The wine shall be delivered to an approved distiller not later than 15 July of the wine year concerned.

In cases covered by Article 68 of this Regulation, the wine shall be delivered to an approved maker of wine fortified for distillation not later than 15 June of the wine year concerned.

To deduct wine from the quantity to be distilled, the wine shall be exported from the Community not later than 15 July of the wine year concerned.

▼ **M9***Article 55***Buying-in price**

1. Within three months of delivery to the distillery distillers shall pay the producers the buying-in price referred to in Article 28(3) of Regulation (EC) No 1493/1999 for the quantity delivered. That price shall apply to bulk merchandise ex producer's premises.

2. In the case of wine obtained from grapes of varieties classified as both wine-grape varieties and varieties for the production of spirits distilled from wine, in accordance with Article 28(3) of Regulation (EC) No 1493/1999, the Member States may vary the buying-in price paid to the producers subject to the distillation obligation as a function of yield per hectare. The provisions adopted by the Member States shall ensure that the average price actually paid for all wine distilled is EUR 1,34/% vol/hl.

*Article 56***Aid to be paid to distillers**

The aid provided for in Article 28(5)(a) of Regulation (EC) No 1493/1999 shall be fixed, in terms of alcoholic strength by volume per hectolitre of product obtained from distillation, as follows:

(a) neutral alcohol:	EUR 0,7728
(b) spirits distilled from wine, raw alcohol and wine distillate:	EUR 0,6401

Where use is made of the possibility of varying the buying-in price in accordance with Article 55(2), the aid referred to in the first paragraph shall vary by an equivalent amount.

No aid shall be payable on alcohol obtained from quantities of wine delivered for distillation that exceed by more than 2 % the amount which the producer must have distilled under Article 53 of this Regulation.

*Article 57***Exceptions to the prohibition on movement of wine**

Where a derogation is granted under Article 28(1) of Regulation (EC) No 1493/1999, wine covered by that Article may be moved to:

- (a) a customs office for completion of customs export formalities followed by departure from the customs territory of the Community, or
- (b) the premises of an approved maker of wine fortified for distillation with a view to fortification.

**▼ B*****Section III: Common provisions applicable to Sections I and II of this Chapter******Article 58*****Partial deliveries****▼ M12**

Producers subject to one of the obligations referred to in Articles 45 and 54 who have delivered at least 90 % of the quantity of product which they are obliged to deliver before 15 July of the current wine year may discharge their obligation by delivering the remaining quantity before a date to be fixed by the competent national authority, which may not be after 31 July of the following wine year.

**▼ B**

In such cases:

**▼ M14**

(a) the buying-in price for remaining quantities as indicated in the first subparagraph and the price for the alcohol produced from them and delivered to the intervention agency shall be reduced by EUR 0,6279/% vol of alcohol and per hectolitre in the case of distillation as indicated in Article 27 of Regulation (EC) No 1493/1999 and by EUR 0,7728/% vol of alcohol and per hectolitre in the case of distillation as indicated in Article 28 of that Regulation,

**▼ B**

(b) no aid shall be paid for products of distillation not delivered to intervention agencies,

**▼ M14**

\_\_\_\_\_

**▼ B**

(d) the time limits for distillation, submission of proof of payment of the price referred to at (a) and delivery of the alcohol to the intervention agency shall be adjusted by the competent authority to take account of the extended time limit for delivery.

***Article 59*****Proof of delivery**

As proof of delivery, distillers shall provide producers, before 31 August of the following wine year, with a certificate stating at least the type, quantity and alcoholic strength by volume of the products delivered, as well as the dates of delivery.

However, where producers deliver the products which they are to have distilled to a distillery located in a Member State other than that in which the products were obtained, the distiller shall require the intervention agency of the Member State of distillation to certify that the distillery has taken over the products in question on the official document provided for in Article 70 of Regulation (EC) No 1493/1999 covering transport of the products. The distiller shall forward a copy of the duly certified document to the producer within one month of receiving the products to be distilled.

**▼M26**

As an exception to the first paragraph, for the 2004/2005, 2005/2006 and 2006/2007 wine years the date referred to therein shall be postponed to 15 September of the following wine year.

**▼B***Article 60***Proofs to be supplied by distillers to intervention agencies**

1. In order to qualify for aid, distillers shall submit an application to the intervention agency, no later than 30 November following the wine year concerned, enclosing for the quantities covered by their application:

- a) (i) in the case of wine and wine lees, a summary of the deliveries made by each producer, stating at least:
  - the type, quantity, colour and alcoholic strength by volume,
  - the number of the document provided for in Article 70(1) of Regulation (EC) No 1493/1999, where such a document is required for transport of the products to the distiller's premises or, otherwise, the reference number of the transport document used under national rules;
- (ii) in the case of grape marc, a list of the names of the producers who have delivered marc and the quantity of alcohol contained in the marc delivered for distillation under Article 27 of Regulation (EC) No 1493/1999;
- (b) a declaration, stamped by the competent authority designated by the Member State, stating at least:
  - (i) the quantity of products obtained by distillation, broken down by category as indicated in Article 43 of this Regulation,
  - (ii) the date on which these products were obtained;
- (c) proof that they have paid the producer the minimum buying-in price laid down for the distillation operation concerned within the time allowed.

However, Member States may provide for simplified arrangements for presenting evidence of the payment of the minimum buying-in price for distillation of the by-products of wine-making after obtaining the agreement of the Commission to such arrangements.

2. Where producers carry out the distillation themselves, the documents referred to in paragraph 1 shall be replaced by a declaration, stamped by the competent authority of the Member State, stating at least:

- (a) the type, quantity, colour and alcoholic strength by volume of the product to be distilled,
- (b) the quantity of products obtained from distillation, broken down by category as indicated in Article 43 of this Regulation,
- (c) the dates on which these products were obtained.

3. Proof that the minimum price has been paid may be replaced by proof that a security has been lodged in favour of the intervention agency. The security shall be equal to 120 % of the aid applied for.

**▼B**

In such cases, proof that the distiller has paid the full buying-in price referred to in Article 27(9) or Article 28(3) of Regulation (EC) No 1493/1999 shall be supplied to the intervention agency no later than the last day of February following the wine year concerned.

4. In cases as referred to in the second subparagraph of Article 47(2) of this Regulation, proof that the buying-in price has been paid shall be replaced by proof that the payment on account has been made.

5. The intervention agency shall pay the aid to the distiller or, in cases as referred to in paragraph 2, the producer no more than three months after submission of the application together with the requisite documents.

**▼M12**

In the case of distillation as referred to in Article 28 of Regulation (EC) No 1493/1999, and where the Member State differentiates the buying-in price according to yield per hectare as provided for in Article 55(2), the period referred to in the first subparagraph shall be seven months.

**▼B***Article 61***Dates of distillation operations**

1. Any wine delivered to meet the obligation laid down in Article 27 of Regulation (EC) No 1493/1999 may not be distilled before 1 January of the wine year concerned.

2. Not later than the 10th of each month, distillers shall send the intervention agency a statement of the quantities of products distilled and products obtained during the previous month, the latter being broken down by category as indicated in Article 43 of this Regulation.

3. Distillation may not take place after 31 July of the wine year concerned.

**▼M26**

However, for the 2004/2005, 2005/2006 and 2006/2007 wine years the date referred to in the first subparagraph shall be postponed to 15 September of the following wine year.

**▼B***Article 62***Delivery of alcohol to the intervention agency**

1. Without prejudice to the application of Articles 27(12) and 28(6) of Regulation (EC) No 1493/1999, distillers may deliver products with an alcoholic strength of at least 92 % vol. to the intervention agency until 30 November following the wine year concerned at the latest.

The operations necessary to obtain the product referred to in the first subparagraph may be carried out either at the premises of the distiller delivering the said product to the intervention agency or at the premises of a jobbing distiller.

Except where the second subparagraph of paragraph 2 of this Article is applied, distillers delivering to the intervention agency may not

**▼ B**

physically keep the delivered alcohol on their premises; it must be stored on premises managed by the intervention agency.

**▼ M8**

Notwithstanding the first subparagraph, as regards Portugal and for the 2000/01 wine year, distillers may deliver products of an alcoholic strength of at least 92 % vol to the intervention agency until 31 December following the wine year concerned at the latest.

**▼ M12**

2. The price to be paid to the distiller by the competent authority for the product delivered shall be fixed in % vol./hl as follows:

(a) distillation under Article 27 of Regulation (EC) No 1493/1999:

- raw alcohol obtained from marc: EUR 1,872,
- raw alcohol obtained from wine and wine lees: EUR 1,437;

(b) distillation under Article 28 of Regulation (EC) No 1493/1999:

- raw alcohol obtained from wine: EUR 1,799.

Where alcohol is stored on the premises where it has been produced, the above prices shall be reduced by EUR 0,5 per hectolitre of alcohol.

**▼ B**

4. In the case of distillers who have received aid under Articles 48 and 56 of this Regulation, the prices referred to in paragraph 2 shall be reduced by an amount equal to the aid.

5. The intervention agency shall pay distillers no more than three months after the day on which the alcohol is delivered, provided the documents and evidence referred to in Article 60 have been presented.

**▼ M11**

CHAPTER II  
OPTIONAL DISTILLATION

*Article 63*

**Purpose**

This chapter lays down the detailed rules for applying the arrangements for distilling wine to produce potable alcohol as referred to in Article 29 of Regulation (EC) No 1493/1999.

*Article 63a*

**Opening of distillation**

**▼ M15**

1. The distillation of table wine and wine suitable for yielding table wine referred to in Article 29 of Regulation (EC) No 1493/1999 shall be opened ► M17 for the period from 1 October to 23 December ◀ each wine year.

▼ **M11**

2. ► **M15** The volume of table wine and wine suitable for yielding table wine for which each producer may sign contracts shall be limited to a percentage to be specified of his wine production declared during one of the last three wine years including the production for the current year if already declared. During a given year the producer may not change the production year chosen as the reference for the calculation of that percentage. ► **M25** For the 2004/2005, 2005/2006, 2006/2007 and 2007/2008 wine years, that percentage shall be 25 %. ◀ ◀

The volume of table wine and wine suitable for yielding table wine produced shall be only that given as wine in the column headed 'Table wines' in the declaration of quantities produced referred to in Table C of Commission Regulation (EC) No 1282/2001 <sup>(1)</sup>.

3. Each producer who, during the current wine year, has produced table wine or wine suitable for yielding table wine may conclude one or more contracts or make one or more declarations as referred to in Article 65 of this regulation. The contracts or declarations shall be accompanied by evidence of the lodging of a security of EUR 5 per hectolitre. Such contracts or declarations may not be transferred.

▼ **M17**

4. Member States shall notify the Commission by 15 January of the current year of the total volume covered by contracts or declarations submitted under Article 65(1) for the distillation referred to in paragraph 1 during the period referred to therein.

▼ **M11**

5. If the quantities covered by contracts or declarations notified to the Commission by the date referred to in paragraph 4 exceed or may exceed the quantities corresponding to available budget resources or are substantially in excess of the absorption capacity of the potable alcohol sector, the Commission shall set a single percentage for acceptance of the quantities covered by the contracts or declarations concerned. In that case, the security referred to in paragraph 3 shall be released for the quantities notified but not accepted.

6. The Member States shall approve such contracts or declarations ► **M17** between 30 January and 20 February ◀:

— for the entire quantity if the Commission has not set the reduction percentage referred to in paragraph 5,

— for the quantity resulting from application of the reduction percentage if one has been set.

However, for the wine year 2002/03 the above dates shall be 1 February and 20 February.

The Member States shall notify the Commission of the total volume under approved contracts by 20 March of the current wine year at the latest.

Contracts or declarations submitted to the competent authorities in the Member States but not notified to the Commission pursuant to paragraph 4 cannot be approved.

▼ **M17**

7. Notwithstanding paragraph 6, Member States may approve contracts before 30 January for a quantity not exceeding 40 % of the quantity given in the contracts or declarations.

<sup>(1)</sup> OJ L 176, 29.6.2001, p. 14.



**▼ M11**

8. The amounts of wine to be supplied under contract shall be delivered to a distillery by 15 July of the wine year at the latest.

**▼ M13**

For the 2002/03 wine year the date in the first subparagraph shall be 31 August of the following wine year.

**▼ M11**

9. The security referred to in paragraph 3 shall be released in proportion to the quantities supplied when the producer provides evidence of delivery to a distillery. Where a contract is performed for at least 95 % of the quantity for which it is concluded the security shall be released in its entirety.

10. The wine supplied to the distillery shall be distilled by 30 September of the following wine year at the latest.

**▼ M13**

For the 2002/03 wine year the date in the first subparagraph shall be 15 November of the following wine year.

**▼ M11***Article 64***Amount of aid and rules applying**

1. The primary aid referred to in Article 29(4) of Regulation (EC) No 1493/1999, to be paid to distillers or, in cases as referred to in Article 65(3) of this Regulation, to producers for wine distilled under this chapter shall be fixed, in terms of alcoholic strength by volume per hectolitre of product obtained from distillation, as follows:

— EUR 1,751/% vol/hl for raw alcohol, wine distillate and spirits distilled from wine,

— EUR 1,884/% vol./hl for neutral alcohol.

Aid applications must be submitted to the competent authority no later than 30 November of the following wine year.

The competent authority shall pay the aid within three months of the date of submission of the proof referred to in Article 65(8) of this Regulation.

2. The secondary aid for the storage of alcohol obtained from distillation referred to in Article 29(6) of Regulation (EC) No 1493/1999 shall be EUR 0,00042/% vol/hl of product obtained from distillation per day.

Storage applications must be submitted to the competent authority not later than one month before the date on which storage is to begin. Applications may concern only alcohol which has already been produced. They shall state at least the quantity and the characteristics of the product to be stored and the anticipated dates of the beginning and end of storage.

Unless the competent authority objects within the above one-month time limit, the date when storage is scheduled to begin shall be deemed to be the actual beginning date.

The secondary aid shall be paid solely to distillers and only:

**▼M11**

- for at least 100 hectolitres of product obtained from distillation stored in containers of a capacity of at least 100 hectolitres, and
- for no less than six months and no more than 12 months. From the seventh month, distillers who have not claimed the advance referred to in Article 66 of this Regulation may terminate the contract in advance by specifying the final date in a statement addressed to the competent authority at least one month before the chosen date.

The quantity of alcohol for which a distiller may conclude storage contracts during a given wine year may not exceed the quantity of products obtained by that distiller by distillation under this chapter during that wine year or one of the two years preceding it.

Distillation products eligible for storage contracts shall have been obtained by the distiller himself during the wine years referred to in the above paragraph or, where applicable, during preceding wine years.

A margin of tolerance of 0,2 % per month calculated in relation to alcohol content shall be allowed for the stored volume of products obtained from distillation. Where that percentage is not exceeded the aid shall remain payable; if it is exceeded no aid shall be paid.

Aid applications must be submitted to the competent authority no later than six months after the end of the storage period. The Member States shall establish the detailed rules for this.

The competent authority shall pay the secondary aid no later than three months after the date on which the aid application was submitted.

**▼M17**

After the submission of the storage application and until the end of the storage period, the containers used and the place of storage may be changed only after obtaining approval from the competent authority.

**▼M11**

3. Distillation products qualifying for aid under this Article may not subsequently be bought in by the public authorities. Should distillers nevertheless wish to sell their alcohol to the public authorities, they must first reimburse the aid they have received.

As an exception, the first subparagraph shall not apply to quantities of alcohol sold by public authorities under programmes that do not interfere with traditional uses, such as agrienvironmental programmes for the sale of alcohol to the fuel sector.

**▼B**

## CHAPTER III

## PROVISIONS COMMON TO CHAPTERS I AND II

*Section I: General**Article 65***Delivery contracts**

1. All producers intending to deliver wine of their own production for distillation under Articles 29 and 30 of Regulation (EC) No 1493/1999 shall conclude one or more delivery contracts, hereinafter referred to as 'contracts', with one or more distillers. Distillers shall present such contracts to the competent intervention agency for

**▼B**

approval before a date to be specified, in accordance with arrangements established by the Member States.

Along with the contract, evidence shall be presented to the intervention agency to prove that producers have actually produced and hold the quantity of wine to be delivered. Such evidence may not be required in the Member States where the authorities already hold relevant such proof under other arrangements.

Producers subject to the obligations laid down in Articles 27 and 28 of Regulation (EC) No 1493/1999 shall also provide distillers with proof that they have fulfilled those obligations during the period set in Article 2(2) of this Regulation.

2. Contracts shall include at least the following information about the wine they cover:

- (a) the quantity, which may not be less than 10 hectolitres,
- (b) the various characteristics, and in particular colour.

Producers may not deliver the wine for distillation unless their contract has been approved by the competent intervention agency. The competent authority may limit the number of contracts that a producer can conclude.

Where distillation is carried out in a Member State other than that in which the contract is approved, the intervention agency which approved the contract shall forward a copy thereof to the intervention agency of the Member State of distillation.

**▼M11**

3. Producers as referred to in paragraph 1 of this article who themselves possess distillation facilities and who intend to carry out the distillation covered by this chapter shall submit a declaration of delivery for distillation, hereinafter referred to as the 'declaration', to the competent authority for approval before a date to be specified.

Producers in wine-growing zone A or in the German part of wine-growing zone B or in areas planted with vines in Austria as referred to in Article 27(7) of Regulation (EC) No 1493/1999 may have the distillation referred to in this chapter carried out on the premises of an approved distiller working on a subcontracting basis. To that end they shall submit a declaration of delivery for distillation, hereinafter referred to as the 'declaration', to the competent authority for approval before a date to be specified.

**▼B**

Producers subject to the obligations referred to in Articles 27 and 28 of Regulation (EC) No 1493/1999 shall also provide the competent intervention agency with proof that they have fulfilled those obligations during the reference period set in Article 2(2) of this Regulation.

**▼M17**

4. For the purposes of paragraph 3, the contract shall be replaced:

- (a) in the case referred to in the first subparagraph of paragraph 3, by the declaration,
- (b) in the case referred to in the second subparagraph of paragraph 3, by the declaration accompanied by a contract for delivery for distillation on the producer's behalf concluded between the producer and the distiller.

**▼ B**

5. The characteristics of the wine delivered for distillation must be the same as those indicated in the contract or declaration covered by this Article.

No aid shall be due:

- (a) if the quantity of wine actually delivered for distillation is less than 95 % of that stated in the contract or declaration;
- (b) for any quantity of wine in excess of 105 % of that stated in the contract or declaration;
- (c) for any quantity of wine over and above the maximum quantity to be complied with for the distillation operation in question.

6. Distillers shall pay producers the prices fixed per % vol. of alcohol and per hectolitre under Article 29 or 30 of Regulation (EC) No 1493/1999 for the wine delivered to them, such prices applying to bulk merchandise ex producer's premises.

7. Distillers shall pay producers the minimum purchase price referred to in paragraph 6 within three months of delivery of the wine, provided the producers have supplied the competent authority with the proof referred to in the third subparagraph of paragraph 1 of this Article within two months of delivery. If the said proof is provided more than two months after delivery, distillers shall pay within one month. ► **M11** Member States may stipulate shorter time limits or specific dates for the presentation of that proof to the competent authorities. ◀

**▼ M17**

Where there are justified doubts about the eligibility of the wine for the distillation concerned, the competent authority of the Member State may extend the payment deadline referred to in the first subparagraph by a maximum of three months.

**▼ M11**

8. Distillers shall forward to the competent authority, within the time limit set by the Member State:

- (a) details of the quantity, colour and actual alcoholic strength by volume of the wine in each delivery from each producer from whom they have received deliveries of wine, together with the number of the document provided for in Article 70 of Regulation (EC) No 1493/1999 used for the transport of the wine to the distiller's premises;
- (b) proof that the total quantity of wine stipulated in the contract or declaration has been distilled within the time allowed;
- (c) proof that they have paid the producer the purchase price referred to in paragraph 6 within the time allowed.

**▼ B**

In the case referred to in paragraph 9, producers shall be required to supply only the proof referred to in (b) above.

Not later than the 10th of each month, distillers shall send the intervention agency a statement of the quantities of products distilled and products obtained during the previous month, the latter being broken down by category as indicated in Article 43 of this Regulation.

9. If distillation is carried out by producers themselves in their capacity as distillers or by distillers acting on the producer's behalf,

**▼B**

the information required under paragraph 8 shall be submitted to the competent intervention agency by the producer.

10. Member States shall carry out representative spot checks on the wine covered by contracts and shall check in particular:

- (a) that the producer has actually produced and holds the quantity of wine to be delivered,
- (b) that the wine entered in the contract belongs to the category for which distillation has been opened.

The check may be made at any time from date of presentation of the contract up to the date it is approved and the wine enters the distillery. Member States with more effective arrangements for checking point (a) in the first subparagraph of this paragraph need carry out checks only as products enter the distillery.

**▼M1**

Where the actual alcoholic strength by volume is indicated in the contract, a discrepancy of 1 % vol shall be permitted between the strength indicated and that determined when the check is carried out.

*Article 65a***Requirements for alcohol obtained by the distillation of certain wines**

Only a product with an alcoholic strength of 92 % vol or more may be obtained by the direct distillation of wines obtained from grapes of varieties classified for the same administrative unit as both wine-grape varieties and varieties intended for the production of wine spirits.

**▼B***Article 66***Advance payments**

1. Distillers or, in the case referred to in Article 65(3) of this Regulation, producers, may request that an amount equal to the aid fixed for the distillation operation concerned be paid them in advance, provided that they have lodged a security in favour of the intervention agency. That security shall be equal to 120 % of the said amount.

The amount referred to in the first subparagraph shall be calculated per % vol. of alcohol indicated for the wine covered by the contract or delivery declaration and per hectolitre of that wine, or by hectolitre of pure alcohol in the case of the secondary aid referred to in Article 64(1) (b) of this Regulation. The intervention agency shall pay advances no more than three months after presentation of proof that the security has been lodged, provided the contract has been approved.

**▼M17**

2. The security shall be released by the intervention agency once the proof referred to in Article 65(8) is presented within the time allowed.

**▼B***Article 67***EAGGF contribution to the cost of distillation operations**

1. The EAGGF Guarantee Section shall finance part of the expenditure incurred by intervention agencies in taking alcohol over.

The financial contribution shall be equal to the aid fixed under Articles 48 and 56 and Article 68(a) of this Regulation and pursuant to Article 3 of Regulation (EC) No 1493/1999.

**▼M12**

The advance on the price to be paid to distillers by the intervention agency, which may be provided for under the distillation referred to in Article 30 of Regulation (EC) No 1493/1999, shall be the same as the aid provided for in the second subparagraph.

**▼B**

2. Articles 4 and 6 of Regulation (EC) No 1258/1999 <sup>(1)</sup> shall apply to the contribution.

***Section II: Fortified wine****Article 68***Processing into fortified wine**

1. Wine to be distilled under this Regulation may be fortified. In such cases, the only product which may be obtained by distilling such fortified wine shall be wine spirits.

2. Wine shall be fortified for distillation only under official supervision.

For this purpose:

- (a) the document(s) and register(s) required under Article 70 of Regulation (EC) No 1493/1999 shall show the increase in actual alcoholic strength by volume, expressed in % vol., by indicating the strength before and after addition of the distillate to the wine,
- (b) a sample of the wine shall be taken under official supervision before it is fortified so that the actual alcoholic strength by volume may be determined by an official laboratory or a laboratory working under official supervision,
- (c) two copies of the report on the analysis referred to in (b) shall be sent to the manufacturer of the fortified wine, who shall transmit one copy to the intervention agency of the Member State in which the wine is fortified.

3. Wine shall be fortified for distillation during the period laid down for the distillation operation in question.

4. Member States may restrict the number of locations at which wine may be fortified for distillation, should this be necessary to ensure that the most effective method of supervision can be used.

<sup>(1)</sup> OJ L 160, 26.6.1999, p. 103.

**▼B***Article 69***Preparation of fortified wine**

1. In cases where the option referred to in Article 68(1) is exercised and where the wine is not fortified by or on behalf of a distiller, producers shall conclude a delivery contract with an approved maker of fortified wine and shall submit it for approval to the competent intervention agency.

However, in the case of producers who are approved as makers of fortified wine and who intend to fortify the wine for distillation themselves, the contract referred to in the first subparagraph shall be replaced by a declaration of delivery.

2. Contracts and declarations as referred to in paragraph 1 shall be covered by rules adopted by the Member States.

3. Makers of fortified wine shall pay producers at least the minimum buying-in price fixed for distillations as provided for in Articles 27 to 30 of Regulation (EC) No 1493/1999 for the wine delivered. That price shall apply to bulk merchandise:

(a) free at maker's premises in the case of distillation under Article 27 (9) of Regulation (EC) No 1493/1999,

(b) ex producer's premises in other cases.

Subject to the necessary adjustments, makers of fortified wine for distillation shall be subject to the same obligations as distillers under this Title.

The aid to be paid to makers of fortified wine shall be fixed per % vol. of actual alcoholic strength and per hectolitre of wine as follows:

— EUR 0.2657 for distillation as provided for in Article 27 of Regulation (EC) No 1493/1999;

— EUR 0.6158 for distillation as provided for in Article 28 of Regulation (EC) No 1493/1999;

— EUR 0.1715 for distillation as provided for in Article 29 of Regulation (EC) No 1493/1999.

**▼M1**

Where the buying-in price is varied as provided for in Article 55(2), the aid referred to in the second indent of the previous subparagraph shall be varied in the same manner.

**▼B**

The competent intervention agency shall pay the aid to makers of fortified wine on condition that they lodge a security equal to 120 % of the aid to be received. However, no security shall be required where all the requirements for payment of the aid have already been met.

Where makers fortify wine in connection with various distillation operations governed by different provisions of Regulation (EC) No 1493/1999, they may lodge a single security. In such cases, the security shall be equal to 120 % of all the aid to be paid for fortification in connection with the said distillation operations.

The intervention agency shall release the security following presentation, within the time allowed:

**▼B**

- (a) of proof that the total quantity of wine fortified for distillation indicated in the contract or declaration has been distilled within the time allowed, and
- (b) of proof that the minimum purchase price referred to in Articles 27, 28, 29 and 30 of Regulation (EC) No 1493/1999 has been paid within the time allowed.

In cases covered by the second subparagraph of paragraph 1, the producer shall be required to supply the intervention agency only with the proof referred to in (a) above.

*Article 70***Distillation in another Member State**

1. Notwithstanding Article 69(4) of this Regulation, where fortified wine is distilled in a Member State other than that in which the contract or declaration was approved, the aid payable for the various distillation operations may be paid to distillers provided that they submit an application no more than two months after the deadline specified for carrying out the distillation operation concerned, to the intervention agency of the Member State in whose territory the distillation has taken place.
2. Applications as referred to in paragraph 1 shall be accompanied by the following:
  - (a) a document, endorsed by the competent authorities of the Member State in whose territory the wine was fortified, transferring entitlement to the aid from the maker of the fortified wine to the distiller and showing the quantities of fortified wine concerned and the amount of the corresponding aid,
  - (b) a copy of the contract or declaration referred to in Article 69(1), approved by the competent intervention agency,
  - (c) a copy of the analysis report referred to in Article 68,
  - (d) proof that the minimum purchase price of the wine has been paid to the producer,
  - (e) the document required under Article 70 of Regulation (EC) No 1493/1999 for the transport of fortified wine to the distillery, showing the increase in actual alcoholic strength by volume, expressed in % vol., by indicating the strength before and after addition of the distillate to the wine,
  - (f) proof that the fortified wine concerned has been distilled.
3. In cases covered by paragraph 1, makers of fortified wine shall not be required to lodge the security provided for in Article 69(4).
4. The intervention agency shall pay the aid not later than three months after the application and the documents listed in paragraph 2 have been submitted.



**▼B***Article 71***Special rules**

1. In cases covered by Article 69(1) of this Regulation, the contract or declaration of delivery for fortification for distillation shall be submitted to the competent intervention agency for approval not later than 31 December of the wine year concerned. The intervention agency shall notify the producer of the outcome of the approval procedure within 15 days of the date on which the contract or declaration is submitted.
2. In cases of distillation under Article 27 of Regulation (EC) No 1493/1999, no wine may be fortified before 1 January of the wine year concerned or before the relevant contract or declaration has been approved.
3. No later than the 10th of each month, makers of fortified wine for distillation shall send the intervention agency a statement of the quantities of wine delivered to them during the previous month.
4. To qualify for the aid, makers of fortified wine shall submit an application to the competent intervention agency, not later than 30 November following the end of the wine year concerned, enclosing proof that the security referred to in Article 69(4) has been lodged.

The aid shall be paid not later than three months after the date of submission of proof that the security referred to in the previous subparagraph has been lodged. It may not be paid until the contract or declaration has been approved.

5. Subject to Article 69(4) of this Regulation, the security shall be released only if the documents referred to in that Article have been supplied to the competent intervention agency within 12 months of submission of the application.
6. If it is found that a maker of fortified wine has not paid the purchase price to the producer, the intervention agency shall pay the producer an amount equal to the aid, before 1 June of the wine year following that in which the wine was delivered, where appropriate through the intervention agency of the producer's Member State.

***Section III: Administrative provisions****Article 72***Force majeure**

1. Where for reasons of *force majeure* all or part of the product to be distilled cannot undergo distillation:
  - (a) if the *force majeure* affected the product to be distilled while it was legally at the disposal of the producer, the latter shall inform the intervention agency of the Member State in which the winery is located without delay,
  - (b) in all other cases, the distiller shall inform the intervention agency of the Member State in which the distillery is located without delay.

In the circumstances referred to in the first subparagraph, as soon as the intervention agency has been informed, it shall decide on the measures

**▼B**

which it considers necessary in view of the circumstances invoked. In particular, it may defer the time limits.

2. In the circumstances referred to at (a) in the first subparagraph of paragraph 1, and where the producer's winery and the distillery are located in two different Member States, the intervention agencies of the two Member States concerned shall cooperate by directly exchanging information in order to implement paragraph 1.

In the circumstances referred to at (b) in the first subparagraph of paragraph 1, as soon as the intervention agency has been informed, it may also authorise distillers, provided the producer agrees in the case of a jobbing distiller, to transfer their rights and obligations to another distiller for the quantity of products not yet distilled.

*Article 73***Supervision of distillation operations**

1. The characteristics of products delivered for distillation, in particular quantity, colour and alcoholic strength, shall be checked against:

- (a) the document provided for in Article 70 of Regulation (EC) No 1493/1999 under cover of which the products are transported,
- (b) an analysis of samples collected under the supervision of an official body of the Member State in which the distillery is located when the product enters the distillery. Sampling may take the form of representative spot checks,
- (c) where appropriate, the contracts concluded under this Title.

The analyses shall be performed by approved laboratories as referred to in Article 72 of Regulation (EC) No 1493/1999, which shall forward the results to the intervention agency of the Member State where distillation takes place.

If, under Community rules, no document as referred to in (a) has been drawn up, the characteristics of the product intended for distillation shall be checked against the analyses referred to in (b).

A representative of an official body shall check the quantity of product distilled, the date of distillation and the quantity and characteristics of the products obtained.

**▼M12****▼B**

3. Member States may also require that an indicator be used. They may not prevent the movement within their territory of products intended for distillation or distilled products obtained therefrom on the ground that an indicator is present.

In cases where products covered by this Regulation are delivered for distillation by more than one producer, Member States may provide that such products are to be transported in bulk. In such cases, checks on the characteristics of the products as referred to in Article 65 shall be carried out in accordance with the detailed rules adopted by the Member State concerned.

**▼B**

4. Member States availing themselves of the option provided for in paragraph 3 shall inform the Commission thereof and shall notify it of the provisions they have adopted for this purpose. In the cases referred to in the first subparagraph of that paragraph, the Commission shall inform the other Member States.

*Article 74***Infringements of this Title**

1. Should verification of a file reveal that a producer does not meet the requirements laid down by the Community rules for the distillation operation in question, for all or part of the products delivered, the competent intervention agency shall inform the distiller and producer concerned accordingly.

2. The distiller concerned shall not be required to pay the price referred to, respectively, in Articles 27, 28, 29 and 30 of Regulation (EC) No 1493/1999 for the quantities of products referred to in paragraph 1.

3. Without prejudice to Article 2 of this Regulation, should a producer or distiller fail to meet the requirements laid down by the Community rules for the distillation operation in question, for all or part of the products delivered for distillation:

- (a) no aid shall be due for the quantities concerned,
- (b) the distiller may not deliver the products obtained by distilling the quantities concerned to the intervention agency.

If the aid has already been paid, the intervention agency shall recover it from the distiller.

If the products obtained by distillation have already been delivered, the intervention agency shall recover an amount equal to the aid specified for the operation concerned from the distiller.

However, where the various time limits laid down by this Regulation have not been met, it may be decided to reduce the aid.

**▼M12**

4. The intervention agency shall recover from the producer an amount equal to all or part of the aid or the advance to be paid to the distiller in cases where a producer does not meet the requirements laid down by the Community rules for the distillation operation in question, for one of the following reasons:

- (a) failure to present the harvest, production or stock declaration within the time allowed;
- (b) presentation of a harvest, production or stock declaration found by the competent authority of the Member State to be incomplete or inaccurate, where the missing or incorrect data are essential for application of the measure concerned;
- (c) failure to meet the obligations laid down in Article 37 of Regulation (EC) No 1493/1999 where the infringement is detected or notified to the distiller after payment of the minimum price on the basis of previous declarations.

**▼M12**

In the case provided for in point (a) of the first subparagraph the amount to be recovered shall be determined in accordance with the rules laid down in Article 12 of Commission Regulation (EC) No 1282/2001 <sup>(1)</sup>.

In the case provided for in point (b) of the first subparagraph the amount to be recovered shall be determined in accordance with the rules laid down in Article 13 of Regulation (EC) No 1282/2001.

In the case provided for in point (c) of the first subparagraph the amount to be recovered shall be all the aid or the advance paid to the distiller.

5. If it is found that the distiller has not paid the purchase price to the producer ►**M17** within the deadline laid down in Article 65(7) plus one month ◀, the intervention agency shall pay the producer, before 1 June following the wine year concerned, an amount equal to the aid or advance, where appropriate through the intermediary of the intervention agency in the producer's Member State. In that case, no aid or advance shall be due to the distiller.

**▼B***Article 75***Penalties**

1. Except in cases of *force majeure*,
  - (a) where producers fail to fulfil their obligations under this Title or refuse to submit to checks, no aid shall be payable;
  - (b) where distillers fail to fulfil one of their obligations other than those referred to in (a) above, the aid shall be reduced by an amount determined by the competent authority depending on the seriousness of the infringement.
2. In cases of recognised *force majeure*, the intervention agency shall take such action as it considers necessary having regard to the circumstances involved.
3. In cases where a distiller fails to fulfil an obligation within the time allowed, the aid shall be reduced as follows:
  - (a) in the case of payment of the purchase price to the producer under Articles 47(2), 55 and 65(7), the aid shall be reduced by 1 % per day of delay for one month. After one month, no aid shall be paid;
  - (b) in the case of:
    - (i) presentation of proof that the minimum purchase price has been paid under Articles 60(1) and 65(8),
    - (ii) submission of the aid application and the proof of payment under Articles 60(1) and the second subparagraph of Article 64(2) and Article 65(8),
    - (iii) delivery of the alcohol under Article 62(1),
    - (iv) submission of a statement of the quantities of products distilled and products obtained under Article 61(2),

<sup>(1)</sup> OJ L 176, 29.6.2001, p. 14.

**▼B**

- (v) submission of a statement of the quantities delivered for fortification under Article 71(3),

the aid shall be reduced by 0.5 % per day of delay for two months.

After two months, no aid shall be paid.

Where an advance on aid has been paid, the corresponding security shall be released in proportion to the aid actually due. Where no aid is due, the security shall be forfeit.

4. Member States shall notify the Commission of cases where they have applied paragraph 1 and of the action taken where *force majeure* has been invoked.

***Section IV: Reduction of the buying-in price for wine provided for in Article 32 of Regulation (EC) No 1493/1999***

*Article 76*

**Reduction of the buying-in price for certain enriched wines**

1. The buying-in price for wine delivered for distillation under Articles 29 and 30 of Regulation (EC) No 1493/1999 shall be reduced by:

- EUR 0.3626 in Zone A,
- EUR 0.3019 in Zone B,
- EUR 0.1811 in Zone C.

The reduction referred to in the first subparagraph shall not apply to:

- (a) wine delivered by producers located in regions where alcoholic strength may be increased only by the addition of must who forego all aid made available under Article 34 of Regulation (EEC) No 1493/1999 for the wine year concerned. These producers shall present to the distiller a copy of a statement waiving entitlement to the aid concerned, stamped by the competent authority designated by the Member State;
- (b) wine taken into a distillery after the dates laid down for the various wine-growing zones in Annex V(G)(7) to Regulation (EC) No 1493/1999 and delivered by producers who provide the competent authorities with satisfactory evidence that during the wine year they have neither increased the alcoholic strength of their table wine by adding sucrose nor lodged an application for aid under Article 34 of that Regulation for their production;
- (c) wine and categories of wine for which the Member States do not authorise or have not authorised an increase in alcoholic strength for the wine year concerned.

2. An amount equal to the reduction referred to in paragraph 1 shall be paid for the quantity of wine delivered for distillation as referred to in that paragraph to producers who apply to the competent authority before 1 August, either directly or through a distiller, and who have neither increased the alcoholic strength of their table wine production by adding sucrose nor applied for aid under Article 34 of Regulation (EC) No 1493/1999 for their production during the wine year concerned.

**▼B**

Producers who apply before 1 August and who have increased alcoholic strength by adding sucrose or have applied for the said aid during the wine year, but for less of their table wine production than the quantity delivered for all the relevant distillation operations during the wine year shall receive the amount indicated in the first subparagraph for the difference between the quantity of table wine of which they increased the alcoholic strength and the quantity they delivered for distillation.

The competent authorities of the Member States may require such producers to supply any evidence needed to demonstrate the validity of their application.

*Article 77***Reduction of the aid referred to in Article 81**

Where wine is delivered for distillation as referred to in Article 76 of this Regulation and where the reduction has been applied to such wine,

- (a) the aid to be paid to the distiller,
- (b) the price to be paid to the distiller for delivery to the intervention agency under Article 30 of Regulation (EC) No 1493/1999 and
- (c) the EAGGF contribution to expenditure incurred by the intervention agency in taking over alcohol under Article 30 of Regulation (EC) No 1493/1999

shall be reduced by an amount equal to the reduction indicated in Article 76.

## CHAPTER IV

**DISPOSAL OF ALCOHOL OBTAINED BY DISTILLATION UNDER CHAPTER I OF THIS TITLE AND, WHERE APPLICABLE, ARTICLE 30 OF REGULATION (EC) No 1493/1999***Article 78***Purpose and definitions**

1. This section lays down detailed rules for disposing of alcohol obtained by distillation under Articles 27, 28 and 30 of Regulation (EC) No 1493/1999, hereinafter referred to as 'alcohol'.

Alcohol may be disposed of either for use in new industrial uses (subsection I), for use in third countries in the fuel sector only (subsection II), or for use as bio-ethanol in the Community (subsection III).

2. For the purposes of this Section, 'tendering procedure' shall mean the organisation of a competition among interested parties in the form of an invitation to tender or similar procedure, the contract being awarded to the party submitting the most advantageous tender complying with the rules laid down in this Regulation.

**▼B*****Subsection I: Disposal of alcohol for new industrial uses******Article 79*****Definition of new industrial uses**

Without prejudice to Article 31(2) of Regulation (EC) No 1493/1999, the Commission may issue invitations to tender for the implementation within the Community of small-scale projects relating to new industrial end uses such as:

- (a) the heating of glasshouses,
- (b) the drying of feedingstuffs,
- (c) the fuelling of heating systems, including those at cement works,

and processing into goods exported for industrial purposes by operators who have made use of inward processing arrangements at least once in the previous two years, other than processing consisting solely of redistillation, rectification, dehydration, purification or denaturing of the alcohol.

If the intended use of the alcohol is export to third countries in the form of manufactured goods, proof must be provided that authorisation was granted during the previous two years to use alcohol from third countries to manufacture under inward processing arrangements the same goods as those exported.

***Article 80*****Opening tendering procedures**

The Commission, acting in accordance with the procedure laid down in Article 75 of Regulation (EC) No 1493/1999, shall issue an invitation to tender for the disposal of alcohol obtained by distillation under Articles 27, 28 and 30 of that Regulation for new industrial uses. The quantities of alcohol awarded under such tendering procedures shall not exceed 400 000 hectolitres of alcohol at 100 % vol. per year.

***Article 81*****Notice of invitation to tender**

Notices issuing invitations to tender shall be published in the *Official Journal of the European Communities*.

Such notices shall specify:

- (a) the special rules applicable to the tendering procedure and the names and addresses of the intervention agencies concerned,
- (b) the quantity of alcohol, expressed in hectolitres of alcohol at 100 % vol., covered by the tendering procedure,
- (c) one or more vats constituting a lot in a given Member State,
- (d) the minimum price which may be offered, differentiated where appropriate according to the end uses,
- (e) the amount of the tendering security required under Article 82(5) and the performance guarantee required under Article 84(3)(b).

**▼B***Article 82***Rules applicable to tenders**

1. Apart from the information specified in Article 97 of this Regulation, tenders shall indicate:
  - (a) the quantity of alcohol to which they relate, broken down by vat and expressed in hectolitres of alcohol at 100 % vol.,
  - (b) the number(s) of the vat(s) in which the alcohol concerned is stored, the vats all being situated in the same Member State,
  - (c) the precise industrial use of the alcohol,
  - (d) the type of goods to be exported if the alcohol is intended for export to third countries in the form of manufactured goods.
2. Tenders may indicate that they are to be considered only if the quantity to be awarded corresponds to the full quantity indicated in the tender.
3. Tenderers may submit only one tender for each type of alcohol, end use and tendering procedure. If a tenderer submits more than one tender per type of alcohol, end use or tendering procedure, none of those tenders shall be admissible.
4. Tenders must reach the intervention agency of the Member State concerned not later than 12 noon Brussels time on the closing date set for the submission of tenders in the notice of invitation to tender. That date must fall between the 15th and the 25th day after the date of publication of the notice of invitation to tender.
5. Tenders shall be valid only if proof is provided before the closing date for the submission of tenders that a tendering security has been lodged with the intervention agency concerned.
6. Not more than two working days after the closing date for submission of tenders, the intervention agency concerned shall communicate to the Commission a list of the names of the tenderers whose tenders are eligible for consideration under Article 97 of this Regulation, the prices offered, the quantities requested, the locations and the types of alcohol concerned and the precise uses to be made of the alcohol.

*Article 83***Award of contracts**

1. The Commission, acting in accordance with Article 75 of Regulation (EC) No 1493/1999, shall decide whether or not to award contracts in the light of the tenders submitted and, where appropriate, depending on the type of end use for which the alcohol is intended.
2. The Commission shall draw up a list of the tenders accepted, listing the prices offered in decreasing order until the contracts awarded cover the entire quantity of alcohol specified in the notice of invitation to tender.
3. Where several admissible tenders relate fully or in part to the same vats, the Commission shall allocate the quantity of alcohol concerned to the tenderer submitting the tender with the highest absolute value.



**▼B**

When making its decision under paragraph 1 of this Article in cases referred to in the first subparagraph where some tenders cannot be met, the Commission may propose to the tenderers concerned that their tenders be accepted for a replacement quantity of alcohol of the same type. In such cases, the relevant tenders shall be deemed to have been accepted provided that the tenderers in question do not express their objection to such transfer in writing to the intervention agency concerned within 10 working days from the date of notification of the Commission decisions referred to in (a) in paragraph 5 of this Article.

To that end, the Commission decision shall indicate the vat in which the replacement quantity of alcohol is stored, in agreement with the intervention agency concerned.

4. Should several tenders propose the same price so that the quantity of alcohol tendered for exceeds the quantity covered by the tendering procedure, the intervention agency concerned shall award the quantity in question:

- (a) either in proportion to the quantities specified in the tenders concerned,
- (b) or by dividing that quantity among the tenderers by agreement with them,
- (c) or by drawing lots.

5. The Commission shall:

- (a) notify the decisions taken under this Article only to those Member States and intervention agencies holding alcohol for which tenders have been accepted,
- (b) publish the results of the tendering procedure in a simplified form in the *Official Journal of the European Communities*.

*Article 84*

**Statement of award**

1. The intervention agency shall notify tenderers in writing, without delay against a receipt, of the decision taken on their tenders.

2. The intervention agency shall hold a statement of award at the disposal of each successful tenderer certifying that their tender has been accepted.

Where the Commission proposes substitution under Article 83(3) and the tenderer does not object, the intervention agency concerned shall issue the statement of award referred to in the first subparagraph on the working day following the expiry of the time limit specified in the last sentence of the second subparagraph of Article 83(3).

3. Within two weeks following the date of receipt of the notification of award referred to in paragraph 1 of this Article and, where the second subparagraph of paragraph 2 is applied, within the two weeks following the date of issue of the statement of award, each successful tenderer shall:

- (a) obtain the statement of award referred to in paragraph 2 from the intervention agency,

**▼B**

- (b) provide the intervention agency concerned with proof that a performance security has been lodged to ensure that the alcohol in question is in fact used for the purposes specified in the tender.

*Article 85***Removal of the alcohol**

1. The alcohol may be removed on presentation of a removal order issued by the intervention agency once the quantity to be removed has been paid for. That quantity shall be determined to the nearest hectolitre of alcohol at 100 % vol.
2. Ownership of the alcohol covered by a removal order shall be transferred on the date indicated in the order, which may not be more than five days after its date of issue, and the quantities concerned shall be deemed to have been removed on that date. From then on, the purchaser shall be responsible for any theft, loss or destruction and for the storage costs of any alcohol awaiting removal.
3. The removal order shall state the date by which the alcohol must be physically removed from the storehouse of the intervention agency concerned.
4. All the alcohol must have been removed four months after the date of receipt of the notification of award.
5. The alcohol must be fully used within two years from the date of first removal.

*Subsection II: Disposal of alcohol for use in third countries in the fuel sector only***▼M12***Article 86***Opening tendering procedures**

The Commission, acting in accordance with the procedure laid down in Article 75 of Regulation (EC) No 1493/1999, may issue one or more invitations to tender every quarter for export to certain third countries for end-use in the motor-fuel sector only. The alcohol concerned must be imported and dehydrated in a third country for end-use in the motor-fuel sector in a third country only.

**▼B***Article 87***Notice of invitation to tender**

1. Notices issuing invitations to tender shall be published in the *Official Journal of the European Communities*.

Such notices shall specify:

- (a) the formalities for the submission of tenders,
- (b) the final use and/or destination for which the alcohol is intended,
- (c) the minimum price which may be offered,

**▼B**

- (d) the Commission department to which tenders should be sent,
  - (e) the time limit for removal of the alcohol stipulated in Article 91(10) of this Regulation,
  - (f) the formalities for obtaining samples,
  - (g) the payment terms,
  - (h) whether the alcohol is to be denatured.
2. Each notice of invitation to tender shall relate to a single lot, although the alcohol constituting the lot may be located in several Member States.
3. Notices of invitation to tender may rule out some of the destinations listed in point 1 of Article 86.

*Article 88***Tenders**

1. Tenderers may submit only one tender in response to each invitation to tender under this subsection; if a tenderer submits more than one, none of those tenders shall be admissible.
2. To be eligible for consideration, tenders must indicate the final destination of the alcohol awarded and contain an undertaking by the tenderer to comply with that destination.
3. Tenders must also include proof, dated after the notice of invitation to tender, that the tenderer has binding commitments to an operator in the fuel sector in one of the third countries listed in Article 86 of this Regulation who undertakes to dehydrate the awarded alcohol in one of those countries and to export it exclusively for use in the fuel sector.
4. Tenders must reach the competent Commission department no later than 12 noon Brussels time on the closing date set for the submission of tenders in the notice of invitation to tender.
5. Tenders shall be valid only if proof has been provided, before the closing date for the submission of tenders, that a tendering security has been lodged with each intervention agency concerned.

The tendering security, amounting to EUR 4 per hectolitre of alcohol at 100 % vol., shall be lodged for the entire quantity put up for sale.

6. For the purposes of paragraph 5, the intervention agencies concerned:
- (a) shall immediately issue tenderers with a statement certifying that the tendering security has been lodged for the quantities for which each intervention agency is responsible,
  - (b) shall forward a list of the tendering securities checked and accepted to the Commission not more than two working days after the closing date for submission of tenders.
7. For the purposes of the tendering security, the primary requirements within the meaning of Article 20 of Commission Regulation (EEC) No 2220/85 shall be that tenders not be withdrawn after

**▼B**

the closing date for their submission and that a security to ensure export and/or a performance guarantee be lodged.

*Article 89***Award of contracts**

1. The Commission, acting in accordance with the procedure laid down in Article 75 of Regulation (EC) No 1493/1999, shall decide as quickly as possible whether or not to award contracts in the light of the tenders submitted.
2. Should a contract be awarded, the Commission shall accept the most favourable tender. If two or more tenders quote the same price, the Commission shall make the award by drawing lots.
3. The Commission shall:
  - (a) inform tenderers in writing against a receipt if their tenders have not been accepted,
  - (b) notify the Member States holding the alcohol and the successful tenderer of its decision to award the alcohol,
  - (c) publish the results of the tendering procedure in a simplified form in the *Official Journal of the European Communities*.
4. The tendering securities required under Article 88(5) of this Regulation shall be released where tenders are not accepted and once the successful tenderer has lodged in full both the export security and the performance guarantee for the tendering procedure concerned.

*Article 90***Statement of award**

The intervention agency shall hold a statement of award at the disposal of successful tenderers certifying that their tender has been accepted.

Statements must be issued no more than 20 days after receipt of the notification from the Commission referred to in Article 89(3) of this Regulation.

*Article 91***Removal of the alcohol**

1. The intervention agency holding the alcohol and the successful tenderer shall agree on a provisional timetable for the removal of the alcohol.
2. Before any alcohol is removed and no later than the day on which the removal order is issued, successful tenderers shall lodge two securities with the intervention agency: one to ensure that the alcohol is exported within the time allowed and the other by way of a performance guarantee.
3. The performance guarantee shall amount to EUR 30 per hectolitre of alcohol at 100 % vol.

**▼B**

4. The export security shall amount to EUR 3 per hectolitre of alcohol at 100 % vol. and shall be lodged for each quantity of alcohol covered by a removal order.

5. Before the awarded alcohol is removed, the intervention agency and the successful tenderer shall take a reference sample and analyse it to verify the alcoholic strength of the alcohol, expressed in % vol.

If the final result of the analyses of this sample reveals a discrepancy between the alcoholic strength by volume of the alcohol to be removed and the minimum alcoholic strength by volume of the alcohol specified in the notice of invitation to tender, the following rules shall apply:

(a) the intervention agency shall inform the Commission, the storer and the successful tenderer thereof on the same day;

(b) the successful tenderer may:

(i) either agree to take over the lot with the characteristics determined by the analysis, provided the Commission so agrees,

(ii) or refuse to take over the lot concerned.

In either case, the successful tenderer shall inform the intervention agency and the Commission on the same day, in the manner specified in Annex V to this Regulation.

Once this requirement has been met, successful tenderers who refuse to take over the lot concerned shall be immediately released from all obligations relating to that lot.

6. Where a successful tenderer refuses the merchandise, in accordance with paragraph 5, the intervention agency concerned shall supply another quantity of alcohol of the required quality at no additional cost within no more than eight days.

7. The alcohol may be removed on presentation of a removal order issued by the intervention agency holding the alcohol once the quantity to be removed has been paid for. That quantity shall be determined to the nearest hectolitre of alcohol at 100 % vol.

Each removal order shall cover a quantity of at least 2 500 hectolitres, except in the case of the last removal in each Member State.

**▼M12**

The removal order shall state the date by which the alcohol must be physically removed from the storehouse of the intervention agency concerned. The deadline for removal may not be more than eight days from the date of issue of the removal order. However, where a removal order covers more than 25 000 hl the deadline may be more than eight days later but no more than 15 days later.

**▼M14**

8. Ownership of the alcohol covered by a removal order shall be transferred on the date indicated in the order, which may not be later than the date specified in compliance with the third subparagraph of paragraph 7.

9. If by the fault of the successful tenderer the alcohol is not removed until after the date stated in the removal order he shall pay the storage costs and theft, loss or destruction shall be at his own risk.

**▼ M14**

If by the fault of the intervention agency the alcohol is not removed until after the date stated in the removal order the Member State shall compensate the tenderer for losses sustained.

**▼ M12**

10. The alcohol must be physically removed from the storehouses of each intervention agency concerned by a deadline to be fixed when the invitation to tender is issued in accordance with the procedure laid down in Article 75 of Regulation (EC) No 1493/1999.

**▼ B**

11. The alcohol must be fully used within two years from the date of first removal.

**▼ M5**

12. The intervention agency concerned shall release the export security for each quantity of alcohol for which it receives proof of export within the time limit allowed. Notwithstanding Article 23 of Regulation (EEC) No 2220/85 and except in cases of *force majeure*, where the time limit for export is exceeded the following percentages of the export security of EUR 3 per hectolitre of alcohol at 100 % vol shall be forfeit:

- (a) 15 % in all cases;
- (b) 0,33 % of the amount remaining after 15 % has been deducted for each day by which the time limit for export has been exceeded.

**▼ B**

13. The performance guarantee shall be released in accordance with Article 100(3)(b) of this Regulation.

***Subsection III: Disposal for use as bio-ethanol in the Community***

**▼ M27**

*Article 92*

**Standing invitation to tender**

1. A standing invitation to tender for alcohol is hereby issued for exclusive use in the fuel sector in the form of bioethanol in the Community.
2. A notice of a standing invitation to tender shall be published in the *Official Journal of the European Union*.

*Article 92a*

**Partial invitations to tender**

1. Intervention agencies shall organise partial tendering rounds during the term of validity of the standing invitation to tender. To that end, intervention agencies shall publish notices of invitation to tender and ensure that they are properly publicised, in particular by displaying them at their head offices and on their website or the website of the competent ministry.
2. The notice of invitation to tender shall indicate in particular the time limit and place for the submission of tenders. Each partial invitation to tender shall cover a maximum quantity of 100 000 hl.

**▼M27**

3. The time limit for the submission of tenders for each partial invitation to tender shall be the last working day of each month at 13.00 Brussels time. No tenders shall be submitted in July and December.
4. The first partial invitation to tender shall take place in the month following that in which the standing invitation to tender is published.
5. Each Member State whose stocks of Community wine alcohol reach or exceed 100 000 hl shall open a partial invitation to tender within the meaning of this Article.

*Article 93***Notices of partial invitations to tender**

For the quantities of alcohol which they hold, intervention agencies shall indicate, in addition to the information referred to in Article 92a (2):

- (a) the special rules applicable to the tendering procedure and the location of the stores in which the alcohol to be sold is stored;
- (b) the quantity of alcohol, expressed in hectolitres of alcohol at 100 % vol., covered by the partial tendering procedure;
- (c) the lots;
- (d) the payment terms;
- (e) the formalities for obtaining samples;
- (f) the amount of the tendering security referred to in the first subparagraph of Article 94(1) and the performance guarantee referred to in Article 94c(3).

*Article 93a***Approval of undertakings**

1. The alcohol shall be awarded to undertakings established in the Community and must be used for the purposes laid down in Article 92.
2. For the purpose of the award referred to in paragraph 1, Member States shall approve undertakings deemed eligible by them which have submitted an application accompanied by the following documents:
  - (a) a declaration by the undertaking stating that it is capable of using at least 50 000 hl of alcohol a year;
  - (b) the location of the undertaking's administrative offices;
  - (c) the names and addresses of the plants where the alcohol is processed into absolute alcohol, and an indication of their annual processing capacity;
  - (d) a copy of the permit granted by the national authorities of the Member State concerned to operate the plants;
  - (e) an assurance by the undertaking that all final purchasers of the alcohol will only use it for the production of fuel in the Community in the form of bioethanol.

**▼M27**

3. Approval by a Member State shall be valid throughout the Community.
4. Undertakings approved by 9 December 2007 shall be considered to have been approved for the purposes of this Regulation.
5. Member States shall inform the Commission without delay of any new approval or withdrawal of approval, indicating the exact date of the decision.
6. After each amendment, the Commission shall make an updated list of the approved undertakings available to the Member States without delay.

*Article 93b***Rule applicable to alcohol**

Intervention agencies shall take the necessary steps to ensure that the alcohol in the vats to which the sale relates is not physically moved until a removal order covering it has been issued, except in the case of a substitution decided by the intervention agency for logistical reasons, the conditions for which shall be clearly set out in the notice of partial invitation to tender.

*Article 93c***Submission of tenders**

1. Undertakings approved by the date of publication of the notice of partial invitation to tender may submit tenders in writing either by delivery by hand to the intervention agency holding the alcohol against proof of receipt, or by any other written means of telecommunication against proof of receipt.
2. Tenderers may submit only one tender in response to a lot. If a tenderer submits more than one, none of those tenders shall be admissible.

*Article 94***Rules applicable to tenders**

1. To be eligible for consideration, tenders, when submitted, must be accompanied by proof that a tendering security of EUR 4 per hectolitre of alcohol at 100 % vol. has been lodged with the intervention agency holding the alcohol concerned.

To that end, the intervention agencies concerned shall immediately issue tenderers with a statement certifying that the tendering security has been lodged for the quantities for which each agency is responsible.

2. The primary requirements within the meaning of Article 20 of Regulation (EEC) No 2220/85 shall be that tenders are not withdrawn after the closing date for their submission, that a performance guarantee is lodged and that the price is paid.



▼ M27*Article 94a***Notifications relating to tenders**

1. On the day following the closing date referred to in Article 92a(3), intervention agencies shall inform the Commission of the lots and the prices offered by tenderers and the quantity of alcohol making up each lot. Intervention agencies shall also indicate whether any tenders have been rejected and, if so, the reasons for such rejection.
2. Intervention agencies shall send this information to the Commission in the form of an anonymous list.
3. If no tenders have been submitted, intervention agencies shall communicate this to the Commission within the same time limit.

*Article 94b***Award of contracts**

1. On the basis of the tenders submitted, the Commission, acting in accordance with the procedure laid down in Article 75 of Regulation (EC) No 1493/1999, shall decide whether or not to award contracts.
2. Should a contract be awarded, the Commission shall accept the most favourable tender per lot and shall set the sale price for each lot. If for the same lot several tenders quote the same price, the intervention body shall allocate the quantity concerned either by sharing the quantity between these tenderers, with their agreement, or by drawing lots.
3. The Commission shall notify the decisions taken under this Article to those Member States and intervention agencies holding alcohol to which tenders have been submitted.
4. The Commission shall publish the results of the tendering procedure in a simplified form in the *Official Journal of the European Union*.

*Article 94c***Statement of award**

1. The intervention agency shall inform tenderers in writing, without delay against a receipt, of the decision taken on their tenders.
2. Within two weeks of the date of receipt of the information notice referred to in paragraph 1, the intervention agency shall issue each successful tenderer with a statement of award certifying that their tender has been accepted.
3. Within two weeks of the date of receipt of the information notice referred to in paragraph 1, each successful tenderer shall provide proof that they have lodged with the intervention agency concerned a performance guarantee of EUR 40 per hectolitre of alcohol at 100 % vol. to ensure that all the alcohol awarded is used for the purposes laid down in Article 92.

**▼M27***Article 94ca***Notifying the Commission**

Within five working days of receipt of the decision referred to in Article 94b(3), the intervention agency shall inform the Commission of the name and address of the tenderer for each tender submitted.

*Article 94d***Removal of the alcohol**

1. The intervention agency holding the alcohol and the successful tenderer shall agree on a provisional timetable for the staggered removal of the alcohol.
2. The alcohol may be removed on presentation of a removal order issued by the intervention agency once the quantity to be removed has been paid for. That quantity shall be determined to the nearest hectolitre of alcohol at 100 % vol.

Each removal order shall cover a quantity of at least 1 500 hectolitres, except in the case of the last removal in each Member State.

The removal order shall state the date by which the alcohol must be physically removed from the warehouse of the intervention agency concerned. The deadline for removal shall not be more than eight days from the day following the date of issue of the removal order. However, where the removal order covers a quantity in excess of 25 000 hectolitres, that deadline may be more than eight days, but not more than 15 days.

3. Ownership of the alcohol covered by a removal order shall be transferred on the date indicated in the order, which may not be after its date of validity, and the quantities concerned shall be deemed to have been removed on that date. From then on, the purchaser shall be responsible for any theft, loss or destruction and for the storage costs of any alcohol awaiting removal.
4. Physical removal of the alcohol must be completed six months after the date of receipt of the notification of acceptance referred to in Article 94c(1).
5. The alcohol must be fully used within two years from the date of first removal.

*Article 94e***Release of the tendering security**

Where a tender has been unsuccessful, the security provided for in Article 94(1) shall be released immediately.

**▼B*****Subsection IV: General provisions and control arrangements*****▼M27***Article 95***Rules applicable to public sales of alcohol**

1. With a view to drawing up the rules for opening a public sale of alcohol, the Commission shall request each Member State concerned to inform it of:

- (a) the quantity of alcohol, expressed in hectolitres of alcohol at 100 % vol., that may be offered for sale;
- (b) the type of alcohol concerned;
- (c) the quality of the lots of alcohol, laying down maximum and minimum values for the characteristics referred to in Article 96(4) (d)(i) and (ii) of this Regulation.

No more than 12 days after receiving this request, the Member States concerned shall inform the Commission of the exact location and references of the various vats of alcohol meeting the quality requirements and containing a total quantity of alcohol not less than that referred to in (a) in the first subparagraph of this paragraph.

2. Once the information referred to in the second subparagraph of paragraph 1 has been forwarded to the Commission, the alcohol in the vats concerned may not be moved until a removal order covering it has been issued.

This prohibition shall not relate to alcohol in vats not covered by the notices of public sale of alcohol concerned or not specified in the Commission decision referred to in Articles 83 to 93.

For logistical reasons in particular, the intervention agencies holding the vats of alcohol specified in the notification from the Member States referred to in paragraph 1 may replace the alcohol concerned with other alcohol of the same type or mix it with other alcohol delivered to the intervention agency until a removal order is issued for the alcohol concerned. The intervention agencies of the Member States shall notify the Commission that the alcohol has been replaced.

*Article 96***Rules applicable to lots**

- 1. The alcohol shall be sold in lots.
- 2. A lot shall consist of a quantity of alcohol of sufficiently uniform quality, which may be contained in several vats and kept at several locations.
- 3. Each lot shall be numbered. The letters ‘EC‘ shall precede the numbers of the lots.
- 4. Each lot shall be described. The following information at least shall be given:
  - (a) the location of the lot, including a reference identifying each vat containing the alcohol, and the quantity of alcohol in each vat;

**▼ M27**

- (b) the total quantity, expressed in hectolitres of alcohol at 100 % vol. The quantity may vary by up to 1 % and may not exceed 50 000 hectolitres;
- (c) the minimum alcoholic strength of the alcohol in each vat, expressed in % vol.;
- (d) if possible, the quality of the lot, specifying upper and lower limits for the following:
  - (i) the acidity, expressed in grams of acetic acid per hectolitre of alcohol at 100 % vol.;
  - (ii) the methanol content, expressed in grams per hectolitre of alcohol at 100 % vol.;
- (e) reference to the intervention measure which gave rise to the production of the alcohol, specifying the relevant Article of Regulation (EC) No 1493/1999.

**▼ B***Article 97***General rules applicable to tenders****▼ M19**

1. To be eligible for consideration, tenders must be submitted in writing and must include, in addition to the specific information referred to in subsections I, II or III:

**▼ B**

- (a) the reference number of the notice of invitation to tender,
  - (b) the name and address of the tenderer,
  - (c) the price proposed, expressed in euros per hectolitre of alcohol at 100 % vol.,
  - (d) an undertaking from tenderers to comply with all the rules applicable to the tendering procedure concerned,
  - (e) a statement by tenderers to the effect that:
    - (i) they waive all claims in respect of the quality and characteristics of the alcohol awarded to them,
    - (ii) they agree to submit to any checks made on the destination and use of the alcohol,
    - (iii) they accept that it is their responsibility to provide evidence that the alcohol is used as specified in the notice of invitation to tender.
2. Tenders shall be valid only if:
- (a) the tenderer is established in the Community,
  - (b) they relate to the entire lot.
3. Tenders eligible for consideration may not be withdrawn.

**▼B**

4. Tenders may be rejected if tenderers do not provide all the necessary guarantees that they will carry out their obligations.

*Article 98***Samples****▼M19**

1. On publication of a notice of invitation to tender and until the closing date for the submission of tenders in response to such invitation, all interested parties may obtain samples of the alcohol offered for sale, against payment of EUR 10 per litre. The quantity made available to each interested party shall not exceed five litres per vat.

2. After the closing date for the submission of tenders, the tenderer or the approved firm referred to in Article 92 may obtain samples of the alcohol awarded.

After the closing date for the submission of tenders, a tenderer to whom a replacement pursuant to the second subparagraph of Article 83(3) is proposed may obtain samples of the replacement alcohol proposed.

Such samples, which may not exceed five litres per vat, may be obtained from the intervention agency against payment of EUR 10 per litre.

**▼B**

3. The intervention agency of the Member State in whose territory the alcohol is held shall take the necessary steps to enable interested parties to avail themselves of the right referred to in paragraph 2.

4. If a successful tenderer or approved firm finds, before the date set in Article 92, Article 85, Article 91 or Article 94 of this Regulation for removal of the lot of alcohol concerned, that a quantity of alcohol awarded is unsuitable for the uses planned owing to hidden defects that by their nature could not be discovered at the time when it was possible for a check to be made before the alcohol was awarded, the Commission may indicate a replacement quantity, in agreement with the relevant intervention agency, provided the latter confirms the tenderer's finding. The vat in which the replacement quantity is stored shall be determined in agreement with the intervention agency concerned. Where tenderers do not object to the transfer by writing to the intervention agency concerned within ten working days of the date of notification of the Commission's decision indicating the replacement quantity, they shall be deemed to have agreed to the substitution.

*Article 99***Requirements applicable to denaturing and/or marking**

1. If alcohol is to be denatured, the operation must take place under the supervision of the Member States concerned between the time when the removal order is handed over and the time when the alcohol is physically removed. The cost of such denaturing shall be borne by the successful tenderer.

2. Denaturing shall involve adding petrol, in the ratio of 1:100, to the quantity of alcohol at 100 % vol.

3. Denaturing may be carried out in a vat provided for this purpose.

*Article 100***Requirements applicable to securities**

For the purposes of this Regulation:

- 1) (a) for the purposes of the tendering security, the primary requirements within the meaning of Article 20 of Regulation (EEC) No 2220/85 shall be that tenders not be withdrawn after the closing date for their submission and that a performance guarantee be lodged;
  - (b) for the purposes of the performance guarantee, the primary requirements within the meaning of Article 20 of Regulation (EEC) No 2220/85 shall be that the alcohol removed be actually used for the purposes specified under the relevant tendering procedure and that the entire quantity of alcohol be physically removed from the stores of each intervention agency concerned within the time allowed.
- 2) (a) The alcohol awarded must be used entirely for the purposes specified in the invitation to tender concerned, allowing for any losses of alcohol during the transport or processing operations required for the final use of the alcohol.

Each individual loss of alcohol shall be accepted only if it has been checked at the final destination and, in the case of alcohol for export, at the place where it left the customs territory of the Community, and certified by the competent inspection authority and/or international surveillance firm where such a firm has been appointed under Article 102, provided that such losses are within the limits specified in point (b) below.

- (b) Where alcohol losses during the operations referred to below exceed the following limits, EUR 96 per hectolitre shall be withheld from the performance guarantee, except in cases of *force majeure*:
  - (i) 0.05 % of the quantities of alcohol stored per month in the case of an alcohol loss due to evaporation,
  - (ii) 0.4 % of the quantities of alcohol removed from storage in the case of an alcohol loss due to one or more land transport operations,
  - (iii) 1 % of the quantities of alcohol removed from storage in the case of alcohol losses due to one or more land transport operations combined with one or more sea or inland waterway transport operations,
  - (iv) 2 % of the quantities of alcohol removed from storage in the case of alcohol losses due to land and sea transport required in connection with a tendering procedure for export of alcohol to one of the third countries listed in Article 86 of this Regulation,
  - (v) 0.9 % of the quantities of alcohol rectified in the case of an alcohol loss due to rectification in the Community,
  - (vi) 0.9 % of the quantities of alcohol dehydrated in the case of an alcohol loss due to dehydration in the Community,

**▼ B**

- (vii) 1.2 % of the quantities of alcohol rectified in the case of an alcohol loss due to rectification in one of the third countries listed in Article 86 to this Regulation,
- (viii) 1.2 % of the quantities of alcohol dehydrated in the case of an alcohol loss due to dehydration in one of the third countries listed in Article 86 to this Regulation.

**▼ M2**

The fifth and/or sixth percentage may be added to the second and third percentages.

The seventh and/or eighth percentage may be added to the fourth percentage.

**▼ B**

When applying the abovementioned percentages, the quantities of alcohol shall be determined on the basis of tonnage certificates or similar documents issued by the competent inspection authorities.

**▼ M19**

- (c) In the case of alcohol awarded for a new industrial use and alcohol awarded under tendering procedures for use as bio-ethanol in the fuel sector in the Community which must be rectified prior to the final use intended, the alcohol removed shall be deemed to have been used entirely for the purpose specified where at least 90 % of the total quantities of alcohol removed under an invitation to tender is used for that purpose.

The tenderer who has agreed to purchase the alcohol shall inform the intervention agency of the quantity, destination and use of the products derived from the rectification.

However, losses may not exceed the limits specified in point (b).

**▼ B**

- 3) (a) The tendering security shall be released immediately if the tender has not been accepted or if the successful tenderer has met the requirements laid down in paragraph 1(a).
- (b) The performance guarantee shall be released immediately by each of the intervention agencies holding alcohol once the successful tenderer provides them each with the proof required in points 2 and 3 and in Title V of Regulation (EEC) No 2220/85, for the relevant quantity removed.
- (c) Notwithstanding Article 27 of Regulation (EEC) No 2220/85, 10 % of the performance guarantee shall be withheld until the successful tenderer provides each intervention agency concerned with proof that the relevant quantity of alcohol removed has been used, indicating any losses of alcohol in connection with the tendering procedure concerned. If such proof is not produced within 12 months after the date specified for the final use of the alcohol, EUR 96 per hectolitre shall be withheld on the quantities of alcohol lost over and above the limits specified in paragraph 2.

**▼B***Article 101***Control arrangements**

1. The Member States concerned shall take the necessary steps to facilitate operations under this Chapter and to ensure that the applicable Community rules are complied with. They shall designate one or more bodies to be responsible for checking compliance with those rules.

The checks shall be at least equivalent to those used to monitor home-produced alcohol but must include:

- (a) physical checks on the quantity of alcohol transported,
- (b) verification of the use made of the alcohol, by frequent spot checks at least once per month,
- (c) verification of accounts, records, utilisation procedures and stocks.

If the alcohol has been denatured checks shall be made at least every two months.

2. The Member States shall determine which documents, records and other supporting evidence or information must be supplied by the successful tenderer. They shall inform the Commission of the checks they introduce to apply paragraph 1. The Commission shall send the Member State concerned any comments required to ensure that checks are effective.

3. The measures taken by the Member States shall be notified to the Commission before the checks start.

**▼M27**

4. Without prejudice to paragraph 1, when the alcohol is exported to third countries for end use in the motor fuel sector only, the checks on its actual use shall be carried out up to the moment when the alcohol is mixed with a denaturing agent in the country of destination.

Where the alcohol is disposed of for use as bioethanol in the Community, those checks shall be carried out up to the moment when the alcohol is delivered to an approved firm as indicated in Article 93a.

In the cases provided for in the first and second subparagraphs, the alcohol concerned must remain under the supervision of an official body which guarantees its use in the motor fuel sector under special tax arrangements which require that enduse.

*Article 102***Use of surveillance firms**

The partial notice of invitation to tender referred to in Article 92a(1) may stipulate that an independent surveillance firm is to be used to check on the proper conduct of the tendering procedure, particularly the final destination and/or end use of the alcohol. The cost of such services shall be borne by the successful tenderer, as shall the cost of analysis and verification pursuant to Article 99 of this Regulation.



**▼ B****TITLE IV  
FINAL PROVISIONS****▼ M12***Article 102a***Derogation from the payment deadlines**

As an exception to the provisions governing the payment deadlines granted to the competent authority of the Member States pursuant to this Regulation, if that authority has justified doubts as to the eligibility of the beneficiary to the aid, it shall carry out the necessary checks and payment shall not be effected until eligibility to the aid has been acknowledged.

**▼ M17***Article 102b***Information regarding the competent authorities**

Member States shall draw up a list of the competent authorities and bodies designated for the purposes of this Regulation, which they shall forward to the Commission electronically. They shall also immediately forward all subsequent amendments to that list.

The Commission shall publish that information on its website.

**▼ M12***Article 103***Notifications to the Commission**

1. In the case of aid for the private storage of wine and must under Title III, Chapter I, of Regulation (EC) No 1493/1999, the Member States shall communicate:

- (a) no later than 31 December of the wine year following that in which the contracts were concluded, the quantities of grape must processed into concentrated grape must or rectified concentrated grape must during the period of validity of the contract, and the quantities so obtained;
- (b) by 5 March of the current wine year at the latest, the quantities of products under contract at 16 February.

**▼ M19**

2. In the case of the distillation referred to in Articles 27, 28 and 30 of Regulation (EC) No 1493/1999, Member States shall communicate at the end of each month:

- (a) the quantities of wine, wine lees and fortified wine which have been distilled in the previous month,
- (b) the quantities of alcohol, broken down into neutral alcohol, raw alcohol and spirits:
  - produced during the previous month,
  - taken over by the intervention agencies during the previous month,

**▼ M19**

- disposed of by the intervention agencies during the previous month and the percentage of those quantities exported and the selling prices charged,
- held by the intervention agencies at the end of the previous month.

**▼ M12**

3. Concerning the disposal of alcohol taken over by the intervention agencies, as referred to in Article 31 of Regulation (EC) No 1493/1999, the Member States shall communicate at the end of each month:

- (a) the quantities of alcohol physically removed during the previous month under a tendering procedure;
- (b) the quantities of alcohol physically removed during the previous month following a public sale.

4. In the case of distillation under Article 29 of Regulation (EC) No 1493/1999, the Member States shall communicate at the end of each month:

- (a) the quantities of wine distilled during the previous month;
- (b) the quantities of alcohol which qualified for secondary aid during the previous month.

5. In the case of aid for concentrated and rectified concentrated must used for enrichment as provided for in Article 34 of Regulation (EC) No 1493/1999, the Member States shall communicate no later than 31 December of the wine year following the current one:

- (a) the number of producers who have received aid;
- (b) the quantities of wine enriched;
- (c) the quantities of concentrated grape must and rectified concentrated grape must used for enrichment, expressed in terms of potential alcoholic strength by volume per hectolitre and broken down by the wine-growing zone of origin.

6. In the case of aid for manufacturing grape juice and other comestible products from such grape juice as provided for in Article 35(1)(a) in Regulation (EC) No 1493/1999, the Member States shall communicate no later than 30 April in respect of the previous wine year:

- (a) the quantities of raw materials covered by aid applications, broken down by type;
- (b) the quantities of raw materials on which aid has been granted, broken down by type.

7. In the case of aid for manufacturing certain products in the United Kingdom and Ireland as provided for in Article 35(1)(b) and (c) of Regulation (EC) No 1493/1999, the Member States shall communicate no later than 30 April in respect of the previous wine year:

- (a) the quantities of grape must and concentrated grape must covered by aid applications, broken down by wine-growing zone of origin;
- (b) the quantities of grape must and concentrated grape must on which aid has been granted, broken down by wine-growing zone of origin;

**▼ M12**

- (c) the prices paid by manufacturers and operators for the grape must and concentrated grape must.
8. The Member States shall communicate:
- (a) no later than 30 April for the previous wine year, the cases where distillers and makers of fortified wine for distillation have failed to fulfil their obligations and the action taken in consequence;
- (b) 10 days before the end of each quarter, the action taken in response to appeals on the grounds of *force majeure* and the steps taken in those instances by the competent authorities in cases covered by this Regulation.

**▼ B***Article 104***Dates and time limits**

The periods, dates and time limits referred to in this Regulation shall be determined in accordance with Regulation (EEC, Euratom) No 1182/71. However, Article 3(4) of that Regulation shall not apply when determining the duration of storage periods under Title II of this Regulation.

*Article 105***Repeal**

Regulations (EEC) No 2682/77, No 1059/83, No 3461/85, No 441/88, No 2598/88, No 2640/88, No 2641/88, No 2721/88, No 2728/88, No 3105/88, No 1238/92, No 377/93 and No 2192/93 are hereby repealed.

*Article 106***Entry into force**

This Regulation shall enter into force on the twentieth day following its publication in the *Official Journal of the European Communities*.

It shall apply from 1 August 2000.

However, the following Regulations shall continue to apply until 31 August 2000 to products from the 1999/2000 wine year:

- Regulation (EEC) No 1059/83,
- Regulation (EEC) No 2640/88,
- Regulation (EEC) No 2641/88,
- Regulation (EEC) No 2721/88,
- Regulation (EEC) No 2728/88,
- Regulation (EEC) No 3105/88.

This Regulation shall be binding in its entirety and directly applicable in all Member States.

**▼B***ANNEX I***▼M12**

**Table of equivalence between the potential alcoholic strength and the readings obtained at 20 °C with a refractometer used in accordance with the method laid down in the Annex to Regulation (EEC) No 558/93**

**▼B**

*(Article 13 of this Regulation)*

Refractomete, reading % (p/p)	Potential alcoholic strength (% vol)	
	Concentrated must	Rectified concentrated must
50,9	34,62	
51,0	34,69	
51,1	34,76	
51,2	34,82	
51,3	34,89	
51,4	34,96	
51,5	35,06	
51,6	35,16	
51,7	35,25	
51,8	35,35	
51,9	35,45	39,07
52,0	35,55	39,17
52,1	35,63	39,26
52,2	35,70	39,35
52,3	35,77	39,45
52,4	35,85	39,54
52,5	35,95	39,63
52,6	36,05	39,73
52,7	36,14	39,83
52,8	36,23	39,93
52,9	36,32	40,02
53,0	36,41	40,12
53,1	36,49	40,22
53,2	36,56	40,30
53,3	36,63	40,40
53,4	36,71	40,50
53,5	36,81	40,59
53,6	36,91	40,69
53,7	37,01	40,79
53,8	37,11	40,89
53,9	37,20	40,99
54,0	37,30	41,09
54,1	37,38	41,18
54,2	37,45	41,28
54,3	37,53	41,37

**▼B**

Refractomete, reading % (p/p)	Potential alcoholic strength (% vol)	
	Concentrated must	Rectified concentrated must
54,4	37,60	41,47
54,5	37,69	41,56
54,6	37,78	41,66
54,7	37,87	41,76
54,8	37,94	41,86
54,9	38,02	41,95
55,0	38,09	42,04
55,1	38,16	42,14
55,2	38,26	42,23
55,3	38,36	42,33
55,4	38,46	42,44
55,5	38,56	42,54
55,6	38,66	42,64
55,7	38,76	42,74
55,8	38,86	42,83
55,9	38,95	42,93
56,0	39,06	43,04
56,1	39,12	43,13
56,2	39,19	43,23
56,3	39,26	43,32
56,4	39,32	43,42
56,5	39,42	43,52
56,6	39,52	43,62
56,7	39,62	43,72
56,8	39,72	43,81
56,9	39,82	43,92
57,0	39,92	44,02
57,1	39,99	44,12
57,2	40,07	44,22
57,3	40,14	44,31
57,4	40,21	44,41
57,5	40,31	44,51
57,6	40,41	44,61
57,7	40,51	44,71
57,8	40,60	44,81
57,9	40,69	44,91
58,0	40,78	45,01
58,1	40,85	45,11
58,2	40,93	45,21
58,3	40,99	45,30
58,4	41,08	45,40

**▼B**

Refractomete, reading % (p/p)	Potential alcoholic strength (% vol)	
	Concentrated must	Rectified concentrated must
58,5	41,17	45.50
58,6	41,27	45.61
58,7	41,37	45.71
58,8	41,47	45.80
58,9	41,57	45.91
59,0	41,67	46.01
59,1	41,77	46.11
59,2	41,87	46.22
59,3	41,97	46.32
59,4	42,06	46.43
59,5	42,14	46.53
59,6	42,23	46.64
59,7	42,31	46.74
59,8	42,38	46.83
59,9	42,46	46.93
60,0	42,53	47.03
60,1	42,63	47.12
60,2	42,73	47.23
60,3	42,83	47.34
60,4	42,93	47.44
60,5	43,03	47.55
60,6	43,12	47.65
60,7	43,20	47.75
60,8	43,27	47.85
60,9	43,35	47.94
61,0	43,42	48.04
61,1	43,51	48.14
61,2	43,60	48.25
61,3	43,69	48.36
61,4	43,79	48.46
61,5	43,89	48.57
61,6	43,99	48.67
61,7	44,08	48.79
61,8	44,18	48.89
61,9	44,28	48.99
62,0	44,38	49.10
62,1	44,48	49.20
62,2	44,58	49.30
62,3	44,65	49.40
62,4	44,73	49.50
62,5	44,80	49.60

**▼B**

Refractomete, reading % (p/p)	Potential alcoholic strength (% vol)	
	Concentrated must	Rectified concentrated must
62,6	44,88	49,71
62,7	44,97	49,81
62,8	45,05	49,91
62,9	45,14	50,02
63,0	45,24	50,12
63,1	45,34	50,23
63,2	45,44	50,34
63,3	45,54	50,45
63,4	45,64	50,56
63,5	45,74	50,67
63,6	45,84	50,77
63,7	45,94	50,88
63,8	46,03	50,99
63,9	46,11	51,08
64,0	46,18	51,18
64,1	46,26	51,29
64,2	46,33	51,39
64,3	46,42	51,49
64,4	46,51	51,60
64,5	46,60	51,71
64,6	46,70	51,81
64,7	46,80	51,92
64,8	46,90	52,03
64,9	46,99	52,14
65,0	47,09	52,25
65,1	47,21	52,36
65,2	47,31	52,46
65,3	47,41	52,57
65,4	47,51	52,68
65,5	47,61	52,79
65,6	47,71	52,90
65,7	47,82	53,01
65,8	47,92	53,12
65,9	48,02	53,22
66,0	48,12	53,34
66,1	48,21	53,44
66,2	48,30	53,54
66,3	48,40	53,64
66,4	48,49	53,75
66,5	48,58	53,86
66,6	48,67	53,96

**▼B**

Refractomete, reading % (p/p)	Potential alcoholic strength (% vol)	
	Concentrated must	Rectified concentrated must
66,7	48,76	54,08
66,8	48,86	54,18
66,9	48,95	54,29
67,0	49,04	54,40
67,1	49,14	54,51
67,2	49,23	54,62
67,3	49,33	54,73
67,4	49,42	54,83
67,5	49,52	54,95
67,6	49,61	55,06
67,7	49,71	55,17
67,8	49,81	55,28
67,9	49,90	55,40
68,0	50,00	55,50
68,1	50,10	55,61
68,2	50,20	55,72
68,3	50,30	55,83
68,4	50,40	55,94
68,5	50,50	56,06
68,6	50,60	56,16
68,7	50,70	56,28
68,8	50,80	56,38
68,9	50,90	56,50
69,0	50,99	56,61
69,1	51,09	56,72
69,2	51,19	56,83
69,3	51,28	56,94
69,4	51,38	57,06
69,5	51,47	57,17
69,6	51,57	57,28
69,7	51,66	57,39
69,8	51,76	57,51
69,9	51,86	57,62
70,0	51,95	57,72
70,1	52,05	57,84
70,2	52,14	57,95
70,3	52,24	58,07
70,4	52,33	58,18
70,5	52,43	58,29
70,6	52,53	58,41
70,7	52,62	58,52



**▼B**

Refractomete, reading % (p/p)	Potential alcoholic strength (% vol)	
	Concentrated must	Rectified concentrated must
70,8	52,72	58,63
70,9	52,81	58,74
71,0	57,91	58,86
71,1	53,01	58,97
71,2	53,11	59,09
71,3	53,21	59,20
71,4	53,31	59,31
71,5	53,41	59,42
71,6	53,51	59,53
71,7	53,61	59,65
71,8	53,71	59,76
71,9	53,81	59,88
72,0	53,91	59,99
72,1	54,00	60,11
72,2	54,10	60,22
72,3	54,20	60,33
72,4	54,30	60,45
72,5	54,40	60,56
72,6	54,50	60,68
72,7	54,60	60,79
72,8	54,70	60,91
72,9	54,80	61,02
73,0	54,90	61,14
73,1	55,00	61,25
73,2	55,10	61,37
73,3	55,20	61,48
73,4	55,30	61,60
73,5	55,40	61,72
73,6	55,50	61,83
73,7	55,60	61,94
73,8	55,70	62,06
73,9	55,80	62,18
74,0	55,90	62,28
74,1	56,00	62,41
74,2	56,09	62,52
74,3	56,19	62,64
74,4	56,29	62,76
74,5	56,39	62,87
74,6	56,49	62,99
74,7	56,59	63,10
74,8	56,69	63,23

**▼ B**

Refractomete, reading % (p/p)	Potential alcoholic strength (% vol)	
	Concentrated must	Rectified concentrated must
74,9	56,79	63,33
75,0	56,89	63,46
75,1		63,58
75,2		63,69
75,3		63,81
75,4		63,93
75,5		64,05
75,6		64,16
75,7		64,28
75,8		64,41
75,9		64,54
76,0		64,66
76,1		64,78
76,2		64,89
76,3		65,02
76,4		65,13
76,5		65,25
76,6		65,37
76,7		65,49
76,8		65,61
76,9		65,74
77,0		65,87
77,1		65,99
77,2		66,09
77,3		66,21
77,4		66,31
77,5		66,45
77,6		66,58
77,7		66,71
77,8		66,82
77,9		66,94
78,0		67,06
78,1		67,19
78,2		67,29
78,3		67,41
78,4		67,52
78,5		67,65
78,6		67,77
78,7		67,89
78,8		68,02
78,9		68,14

**▼ B**

Refractomete, reading % (p/p)	Potential alcoholic strength (% vol)	
	Concentrated must	Rectified concentrated must
79,0		68,26
79,1		68,38
79,2		68,51
79,3		68,62
79,4		68,75
79,5		68,87
79,6		69,00
79,7		69,12
79,8		69,24
79,9		69,35

**▼B***ANNEX II***Minimum quality requirements for table wines provided for in Article 27(b)  
(i) of this Regulation***I. White wines*

- (a) Minimum actual alcoholic strength: 10.5 % vol.
- (b) Maximum volatile acidity: 9 milliequivalents per litre
- (c) Maximum sulphur dioxide content: 155 milligrams per litre

*II. Red wines*

- (a) Minimum actual alcoholic strength: 10.5 % vol.
- (b) Maximum volatile acidity: 11 milliequivalents per litre
- (c) Maximum sulphur dioxide content: 115 milligrams per litre

Rosé wines must comply with the requirements laid down above for red wines, except as regards their sulphur dioxide content, which must comply with the maximum levels fixed for white wines.

However, red table wines from the Portugieser vine varieties and white table wines from the Sylvaner, Müller-Thurgau and Riesling vine varieties shall not be required to comply with points (a) and (c) above.

**▼B***ANNEX III***Definition of neutral alcohol referred to in Article 43 of this Regulation**

1. Organoleptic characteristics	No extraneous flavour detectable in the raw material
2. Minimum alcoholic strength by volume:	96 % vol.
3. Maximum values of residue elements:	
— Total acidity expressed in g of acetic acid per hl of alcohol at 100 % vol.	1.5
— Esters expressed in g of ethyl acetate per hl of alcohol at 100 % vol.	1.3
— Aldehydes expressed in g of acetaldehyde per hl of alcohol at 100 % vol.	0.5
— Higher alcohols expressed in g of 2-methylpropanol-1 per hl of alcohol at 100 % vol.	0.5
— Methanol expressed in g per hl of alcohol at 100 % vol.	50
— Dry extract expressed in g per hl of alcohol at 100 % vol.	1.5
— Volatile bases containing nitrogen expressed in g of nitrogen per hl of alcohol at 100 % vol.	0.1
— Furfural	Not detectable

▼ **M12***ANNEX IV***COMMUNITY ANALYSIS METHOD FOR NEUTRAL ALCOHOL****I. GENERAL**

For the purposes of this Annex:

- (a) the repeatability limit is the value below which the absolute difference between two single test results obtained under the same conditions (same operator, same apparatus, same laboratory and a short interval of time) may be expected to lie with a specified probability;
- (b) the reproducibility limit is the value below which the absolute difference between two single test results obtained under different conditions (different operators, different apparatus and/or different laboratories and/or different time) may be expected to lie with a specified probability.

The term 'single test result' means the value obtained when the standardised test method is applied fully once to a single sample. Unless otherwise stated, the probability shall be 95 %.

**II. METHODS****Introduction****1. PREPARATION OF THE SAMPLE FOR ANALYSIS****1.1. General**

The volume of laboratory sample intended for analysis must normally be 1,5 l unless a larger quantity is required for a specific determination.

**1.2. Sample preparation**

The sample shall be made homogeneous before analysis.

**1.3. Preservation**

The prepared sample shall always be kept in an air-tight and moisture-tight container and stored so that deterioration is prevented; in particular seals of cork, rubber and plastic should not come into direct contact with the alcohol and the use of sealing wax is expressly prohibited.

**2. REAGENTS****2.1. Water**

2.1.1. Wherever mention is made of water for solution, dilution or washing purposes, dilution or washing purposes, distilled water, or demineralised water of a least equivalent purity shall be used.

2.1.2. Wherever reference is made to 'solution' or 'dilution', without further indication of a reagent, an aqueous solution is intended.

**2.2. Chemicals**

All chemicals shall be of analytical reagent quality except where otherwise specified.

**3. EQUIPMENT****3.1. List of equipment**

The list of equipment contains only those items with a specialised use and items with a particular specification.

**3.2. Analytical balance**

Analytical balance means a balance with a sensitivity of 0,1 mg or better.

**4. EXPRESSION OF RESULTS****4.1. Results**

**▼M12**

The result stated in the analytical report is the mean value obtained from at least two determinations, the repeatability ( $r$ ) of which is satisfactory.

## 4.2. Calculation of results

Except where otherwise specified, the results shall be calculated as g per hl of ethanol at 100 % vol.

## 4.3. Number of significant figures

The result shall not contain more significant figures than are justified by the precision of the method of analysis used.

**Method 1: Determination of alcohol content**

The alcoholic strength by volume of the alcohol shall be determined in accordance with existing national provisions or, in the event of dispute, by means of alcoholometers or hydrometers as defined in Council Directive 76/765/EEC of 27 July 1976 on the approximation of the laws of the Member States relating to alcoholometers and alcohol hydrometers <sup>(1)</sup>.

It shall be expressed as percentage by volume, as prescribed by Council Directive 76/766/EEC of 27 July 1976 on the approximation of the laws of the Member States relating to alcohol tables <sup>(2)</sup>.

**Method 2: Evaluation of colour and/or clarity**

## 1. SCOPE AND FIELD OF APPLICATION

The method enables the colour and/or clarity of neutral alcohol to be assessed.

## 2. DEFINITION

The colour and/or clarity: the colour and/or clarity as assessed by the procedure specified.

## 3. PRINCIPLE

The colour and clarity are assessed visually by comparison with water against a white background and a black background respectively.

## 4. APPARATUS

Glass cylinders, colourless, at least 40 cm in height.

## 5. PROCEDURE

Place two glass cylinders (4) on the white background or black background and fill one cylinder with sample to a depth of approximately 40 cm and the other with water to the same depth.

Observe the sample from above i.e. through the length of the cylinder, and compare it with the comparison cylinder.

## 6. INTERPRETATION

Assess the colour and/or clarity of the sample when observed as set out in 5.

**Method 3: Determination of permanganate clearing time**

## 1. SCOPE AND FIELD OF APPLICATION

The method determines the permanganate clearing time of neutral alcohol.

## 2. DEFINITION

The permanganate clearing time, as determined by the method specified, is the number of minutes required for the colour of the sample to match that of the colour standard after adding 1 ml of a 1 mmol/l potassium permanganate solution to 10 ml of the sample.

<sup>(1)</sup> OJ L 262, 27.9.1976, p. 143.

<sup>(2)</sup> OJ L 262, 27.9.1976, p. 149.

**▼M12**

## 3. PRINCIPLE

The time for the colour of the sample, after addition of potassium permanganate, to match that of a colour standard is determined and defined as the permanganate clearing time.

## 4. REAGENTS

4.1. Potassium permanganate solution, 1 mmol/l. Prepare immediately before use.

4.2. Colour solution A (red)

— Weigh accurately 59,50 g  $\text{CoCl}_2 \cdot 6\text{H}_2\text{O}$ ,

— prepare a mixture of 25 ml hydrochloric acid ( $P^{20} = 1,19$  g/ml) and 975 ml water,

— add the cobalt chloride to some of the HCl/water mixture in a 1 000 ml volumetric flask and make up to the mark with the rest of the mixture at 20 °C.

4.3. Colour solution B (yellow)

— Weigh accurately 45,00 g  $\text{FeCl}_3 \cdot 6\text{H}_2\text{O}$ ,

— prepare a mixture of 25 ml hydrochloric acid ( $P^{20} = 1,19$  g/ml) and 975 ml water and then proceed with the weighed quantity of ferric chloride as for colour solution A.

4.4. Colour standard solution

Pipette 13 ml of colour solution A and 5,5 ml colour solution B into a 100 ml volumetric flask and make up to the mark with water at 20 °C.

*Note:*

Colour solutions A and B may be stored in the dark at 4 °C for several months; the colour standard should be freshly prepared from time to time.

## 5. APPARATUS

5.1. 100 ml Nessler tubes of colourless transparent glass, graduated to 50 ml, with ground-glass stopper, or test tubes, colourless, circa 20 mm diameter.

5.2. Pipettes, 1, 2, 5, 10 and 50 ml.

5.3. Thermometer, range up to 50 °C in 0,1 or 0,2 °C.

5.4. Analytical balance.

5.5. Water bath, thermostatically controlled at  $20 \pm 0,5$  °C.

5.6. Volumetric flasks, 100 and 1 000 ml with ground glass stoppers.

## 6. PROCEDURE

6.1. — Pipette 10 ml of the sample into a test tube or 50 ml in a Nessler tube,

— place in water bath at 20 °C,

— add 1 ml or 5 ml, depending on the sample quantity used, of 1 mmol/l  $\text{KMnO}_4$  solution, mix and leave in the water bath at 20 °C,

— note the time,

— pipette 10 ml of the colour standard into a test tube of the same diameter or 50 ml of the colour standard into a Nessler tube,

— observe the change of colour of the sample and compare it with the colour standard against a white background from time to time,

— note the time at which the colour of the sample becomes the same as that of the colour standard.



**▼M12***Note:*

Take care not to expose the sample solution to direct sunlight during the test.

## 7. EXPRESSION OF RESULTS

- 7.1. Interpretation of the time of clearing shall be the time required for the colour of the sample tube to match that of the standard tube.

For a neutral alcohol that time must be at least 18 minutes at a temperature of 20 °C.

- 7.2. Repeatability

The difference in the times of two tests, carried out simultaneously or in rapid succession, by the same analyst, on the same sample, under the same conditions, shall not exceed two minutes.

## 8. NOTES

- 8.1. Traces of manganese dioxide have a catalysing effect on the reaction, ensure that pipettes and test tubes are used which have been scrupulously cleaned and reserved exclusively for the purpose. Clean them with hydrochloric acid and rinse thoroughly with water, no brown coloration shall be visible on the glass apparatus.
- 8.2. The quality of the water to prepare the dilute permanganate solution (4.1) shall be carefully monitored; it must not consume any permanganate. If the required quality cannot be obtained, distilled water should be brought to the boil and a small quantity of permanganate added in order to obtain a very slightly pink coloration. This should then be cooled and used for the dilution.
- 8.3. For some samples the decoloration may occur without passing through the exact shade of the reference solution.
- 8.4. The permanganate test may be distorted when the alcohol sample for analysis has not been stored in a perfectly clean glass flask, sealed with either a ground glass stopper which has been rinsed with alcohol or another stopper encased in tin or aluminium.

**Method 4: Determination of aldehydes**

## 1. SCOPE AND FIELD OF APPLICATION

The method determines aldehydes, expressed as acetaldehyde, in neutral alcohol.

## 2. DEFINITION

The aldehyde content: the content of aldehydes, expressed as acetaldehyde, as determined by the method specified.

## 3. PRINCIPLE

The colour obtained after the reaction of the sample with Schiff's reagent is compared with standard solutions having a known acetaldehyde content.

## 4. REAGENTS

p-rosaniline hydrochloride (basic fuchsin)

sodium sulphite or anhydrous sodium metabisulphite

hydrochloric acid, density  $p^{20} = 1.19$  g/ml

powdered active carbon

starch solution, prepared from 1 g soluble starch and 5 mg  $HgI_2$  (preservative) which are suspended in a little cold water, mixed with 500 ml boiling water, boiled for 5 minutes and filtered when cold.

iodine solution, 0,05 mol/l

1-amino-ethanol  $CH_3 \cdot CH(NH_2)OH$  (MW 61.08)

Schiff's reagent

— Dissolve 5,0 g powdered p-rosaniline hydrochloride with about 1 000 ml hot water in a 2 000 ml volumetric flask,

**▼M12**

- leave in the water bath until completely dissolved if necessary,
- dissolve 30 g anhydrous sodium sulphite (or an equivalent quantity of sodium metabisulphite) in circa 200 ml water and add to the cool prosaniline solution,
- leave to stand for about 10 minutes,
- add 60 ml hydrochloric acid ( $p^{20} = 1,19$  g/ml),
- where the solution is colourless — a slight degree of brown colouration can be ignored — make up to the mark with water,
- if necessary filter with a little active carbon over a folded filter to render the solution colourless.

*Notes:*

- (1) The Schiff's reagent should be prepared at least 14 days before it is used.
- (2) The free SO<sub>2</sub> content in the reagent should be between 2,8 and 6,0 mmol/100 ml, the pH must be 1.

Determination of free SO<sub>2</sub>

- Pipette 10 ml Schiff's reagent into a 250 ml Erlenmeyer flask,
- add 200 ml water,
- add 5 ml starch solution,
- titrate with 0,05 mol/l iodine solution to starch end-point, if the free SO<sub>2</sub> content is outside the indicated range it should either be:
  - raised with a calculated quantity of sodium metabisulphite (0,126 g Na<sub>2</sub>SO<sub>3</sub>/100 ml reagent per mmol SO<sub>2</sub> lacking), or
  - lowered by bubbling air through the reagent.

Calculation of free SO<sub>2</sub> in the reagent.mmol free SO<sub>2</sub>/100 ml reagent:

$$= \frac{\text{consumed ml iodine solution (0,05 mol/l)} \cdot 3,2 \cdot 100}{64 \cdot 10}$$

$$= \frac{\text{consumed ml iodine solution (0,05 mol/l)}}{2}$$

*Important:*

It other methods are used to prepare the Schiff's reagent, the sensitivity of the reagent should be checked so that during the test:

- there is no colouration with the aldehyde-free reference alcohol,
  - the pink colouration should be visible from 0,1 g acetaldehyde per hl alcohol at 100 % vol.
- (3) Purification of commercial 1-amino-ethanol
    - Dissolve 5 g 1-amino-ethanol completely in circa 15 ml absolute ethanol,
    - add circa 50 ml dry diethyl ether (1-amino-ethanol precipitates),
    - leave for several hours in a refrigerator,
    - filter off the crystals and wash with dry diethyl ether,
    - dry for three to four hours in a desiccator over sulphuric acid in a partial vacuum.

*Note:*

The cleaned 1-amino-ethanol must be white; if not, repeat the recrystallisation process.

**▼M12**

## 5. APPARATUS

- 5.1. Colorimetric tubes, each provided with a ground-glass stopper, capacity 20 ml.
- 5.2. 1 ml, 2 ml, 3 ml, 4 ml, 5 ml and 10 ml pipettes.
- 5.3. Water bath, thermostatically controlled at  $20 \pm 0,5$  °C.
- 5.4. Spectrophotometer with cuvettes of 50 mm path length.

## 6. PROCEDURE

## 6.1. Preliminary remark

When using this method to determine aldehyde content ensure that the sample's alcohol content is at least 90,0 % vol. If not it must be raised by adding corresponding amounts of aldehyde-free ethanol.

## 6.2. Calibration curve

- Weigh 1,3860 g purified and dried 1-amino-ethanol accurately on an analytical balance.
- Place in a 1 000 ml volumetric flask and add aldehyde-free ethanol-free ethanol, make up to the mark at 20 °C. The solution content 1 g/l acetaldehyde.
- Prepare the dilution series in two stages to produce 10 reference solutions containing 0,1 to 1,0 mg acetaldehyde per 100 ml solution.
- Determine the absorbance values for these reference solutions according to 6.3 and construct graph.

## 6.3. Determining the aldehyde content

- Pipette 5 ml of the sample into a colorimetric tube.
- Add 5 ml water, mix and keep at a constant temperature of 20 °C.
- At the same time make a blank using 5 ml aldehyde-free ethanol at 96 % vol, add 5 ml water and keep at a temperature of 20 °C.
- Then add 5 ml Schiff's reagent to each tube, close with ground-glass stoppers and shake well.
- Keep in water bath for 20 minutes at 20 °C.
- Put contents into cuvettes.
- Determine absorbance values at 546 nm.

*Notes:*

- (1) To determine the aldehyde figures it is necessary to check the validity of the calibration curves by comparison with test solution; if not, the calibration curve must be prepared again.
- (2) Ensure that the blank is always colourless.

## 7. EXPRESSION OF RESULTS

## 7.1. Formula and method of calculation

Construct a graph of optical density against concentration of acetaldehyde and determine the concentration in the sample by reference to this plot.

The content of aldehydes, expressed as acetaldehyde, in g/hl ethanol at 100 % vol is given by

$$\frac{100 \cdot A}{T}$$

where:

$A$  = the content, in g per hl of acetaldehyde in the sample solution as determined by reference to the standard curve,

▼ **M12**

$T$  = the alcoholic strength by volume of the sample as determined by method 1.

## 7.2. Repeatability

The difference between the results of two determinations, carried out simultaneously or in rapid succession, by the same analyst, on the same sample, under the same conditions, shall not exceed 0,1 g aldehyde per hl Ethanol at 100 % vol.

**Method 5: Determination of higher alcohols**

## 1. SCOPE AND FIELD OF APPLICATION

The method determines budget alcohols, expressed as 2-methylpropan-1-ol, in neutral alcohol.

## 2. DEFINITION

The higher alcohol content: the content of higher alcohols, expressed as 2-methylpropan-1-ol as determined by the method specified.

## 3. PRINCIPLE

The absorbance of the coloured products resulting from the reaction of higher alcohols and an aromatic aldehyde in hot dilute sulphuric acid (Komarowsky reaction) are determined at 560 nm, corrected for the presence of any aldehyde in the sample and then compared with that produced by 2-methylpropan-1-ol reacting under the same conditions.

## 4. REAGENTS

4.1. Salicyl aldehyde solution, 1 % mas. Prepare by adding 1 g of salicyl aldehyde to 99 g of ethanol at 96 % vol (which is free of fusel oil).

4.2. Sulphuric acid, concentrated, density 1,84 g/m<sup>3</sup>.

4.3. 2-methylpropan-1-ol.

4.4. Standard 2-methylpropan-1-ol solutions

Dilute 2-methylpropan-1-ol (4.3) with an aqueous solution of 96 % vol ethanol to give a series of standards containing 0,1, 0,2, 0,4, 0,6 and 1,0 g of 2-methylpropan-1-ol per hl of solution.

4.5. Standard acetaldehyde solutions.

Prepare the standard acetaldehyde solutions as described in section 6.2 of method 4.

4.6. Ethanol 96 % vol free from higher alcohols and aldehydes.

## 5. APPARATUS

5.1. UV-VIS spectrophotometer, capable of determining absorbance of solutions at 560 nm.

5.2. Spectrophotometer cuvettes, 10, 20 and 50 mm pathlengths.

5.3. Water bath, thermostatically regulated at 20 ± 0,5 °C.

5.4. Colorimetric tubes made of thick glass Pyrex or similar with ground-glass stoppers, content circa 50 ml.

## 6. PROCEDURE

## 6.1. Aldehyde content

Determine the aldehyde content, expressed as acetaldehyde, in the sample using method 4.

## 6.2. Calibration curve: 2-methylpropan-1-ol

Pipette 10 ml of each of the 2-methylpropan-1-ol standards (4.4) into 50 ml glass cylinders each fitted with ground glass stoppers. Pipette 1 ml of the salicyl aldehyde solution (4.1) into the cylinders and then 20 ml of sulphuric acid (4.2). Mix the contents thoroughly by carefully tilting the cylinders backwards and forwards several times (care being taken to lift the stopper in occasionally). Leave for 10 minutes at room temperature and then put in the water bath (5.3) at 20 ± 0,5 °C. After 20 minutes pour the contents into a series of spectrophotometer cuvettes.

▼ **M12**

Exactly 30 minutes after adding the sulphuric acid determine the absorbance of the solutions at 560 nm using water in the reference cuvette of the spectrophotometer.

Construct a calibration curve of absorbance against 2-methylpropan-1-ol concentration.

## 6.3. Calibration curve — aldehydes

Repeat 6.2 but replacing the 10 ml of each of the 2-methylpropan-1-ol standards by 10 ml of each of the acetaldehyde standards.

Construct a calibration curve of absorbance at 560 nm against acetaldehyde concentration.

## 6.4. Sample determination

Repeat 6.2 but replacing the 10 ml of the 2-methylpropan-1-ol standards by 10 ml of the sample.

Determine the absorbance of the sample.

## 7. EXPRESSION OF RESULTS

## 7.1. Formula and method of calculation

7.1.1. Correct the absorbance of the sample by subtracting the value of the absorbance corresponding to the aldehyde concentration in the sample (obtained from the calibration curve constructed under 6.3).

7.1.2. Determine the concentration of higher alcohols, expressed as 2-methylpropan-1-ol, in the sample from the calibration curve constructed under 6.2 but using the correct absorbance (7.1.1).

7.1.3. The concentration of higher alcohols, expressed as 2-methylpropan-1-ol in g per hl ethanol at 100 % vol, is given by:

$$\frac{A \cdot 100}{T}$$

where:

A = the concentration of higher alcohols in the sample as calculated in 7.1.2.

T = the alcoholic strength by volume of the sample as determined by method 1.

## 7.2. Repeatability

The difference between the results of two determinations, when carried out simultaneously or in rapid succession, by the same analyst, on the same sample, under the same conditions, shall not exceed 0,2 g per hl ethanol at 100 % vol.

**Method 6: Determination of total acidity**

## 1. SCOPE AND FIELD OF APPLICATION

The method determines the total acidity, expressed as acetic acid, of neutral alcohol.

## 2. DEFINITION

The total acidity content, expressed as acetic acid: the content of total acidity, expressed as acetic acid, as determined by the method specified.

## 3. PRINCIPLE

The sample, after de-gassing, is titrated against standard sodium hydroxide solution and the acidity calculated as acetic acid.

## 4. REAGENTS

4.1. Sodium hydroxide solutions, 0,01 mol/l and 0,1 mol/l, stored so that contact with carbon dioxide is minimised.

4.2. Indigo carmine solution (A)

— Weigh 0,2 g indigo carmine,

**▼M12**

— dissolve in 40 ml water and make up to 100 g with ethanol.

Phenol red solution (B)

— Weigh 0,2 g phenol red,

— dissolve in 6 ml sodium hydroxide 0,1 mol/l and make up to mark with water in a 100 ml volumetric flask.

5. APPARATUS

5.1. Burette or automatic titrater.

5.2. Pipette, 100 ml.

5.3. Round-bottom flask with ground-glass stopper, 250 ml.

5.4. Reflux condenser with ground-glass stopper.

6. PROCEDURE

— Pipette 100 ml of the sample into the 250 ml round-bottom flask,

— add boiling stones and briefly heat to boiling in the reflux condenser,

— add one drop of each of indicator solutions A and B to the hot solution,

— then titrate with sodium hydroxide 0,01 mol/l until the first signs of change from greenish-yellow to violet.

7. EXPRESSION OF RESULTS

7.1. Formula and method of calculation

The content of total acidity, expressed as acetic acid, in g per hl ethanol at 100 % vol is given by:

$$\frac{V \cdot 60}{T}$$

where:

V = the number of ml of 0,01 mol/l sodium hydroxide required for neutralisation.

T = the alcoholic strength by volume of the sample as determined by method 1.

7.2. Repeatability

The difference between the results of two determinations, carried out simultaneously or in rapid succession, by the same analyst, on the same sample, under the same conditions, shall not exceed 0,1 g per hl ethanol at 100 % vol.

**Method 7: Determination of esters**

1. SCOPE AND FIELD OF APPLICATION

The method determines esters, expressed as ethyl acetate, in neutral alcohol.

2. DEFINITION

The ester content: the content of esters, expressed as ethyl acetate, as determined by the method specified.

3. PRINCIPLE

Esters react quantitatively with hydroxylamine hydrochloride in alkaline solution to form hydroxylamic acids. These then form coloured complexes with ferric ions in acid solution. The optical densities of these complexes are measured at 525 nm.

4. REAGENTS

4.1. Hydrochloric acid 4 mol/l.

4.2. Ferric chloride solution, 0,37 mol/l in 1 mol/l hydrochloric acid.

**▼M12**

- 4.3. Hydroxylamine Hydrochloride, 2 mol/l. Store in a refrigerator.
- 4.4. Sodium hydroxide solution, 3,5 mol/l.
- 4.5. Ethyl acetate standard solutions containing 0,0, 0,2, 0,4, 0,6, 0,8 and 1,0 g ethyl acetate per hl ester-free ethanol at 96 % vol.

## 5. APPARATUS

- 5.1. Spectrophotometer with 50 mm pathlength cuvettes.

## 6. PROCEDURE

## 6.1. Calibration curve

- Weigh accurately 1,0 g ethyl acetate on an analytical balance,
- add ester-free alcohol in a 1 000 ml volumetric flask and make up to the mark at 20 °C,
- prepare dilution series in two stages to produce 20 reference solutions containing 0,1 to 2,0 mg ethyl acetate per 100 ml solution,
- determine absorbance values for the reference solution in accordance with 6.2 and construct a graph.

## 6.2. Determination of ester content

- Pipette 10 ml of the sample into test-tubes fitted with ground-glass stoppers,
- add 2 ml hydroxylamine hydrochloride solution,
- at the same time prepare a blank using 10 ml ester-free ethanol at 96 % vol and 2 ml hydroxylamine hydrochloride solution,
- then add 2 ml sodium hydroxide to each solution, close the tubes with ground-glass stoppers and shake well,
- keep for 15 minutes at 20 °C in a water bath,
- add 2 ml hydrochloric acid to each tube, shake briefly,
- add 2 ml ferric chloride solution, mix well,
- pour contents into cuvettes,
- Determine absorbance values at 525 nm.

## 7. EXPRESSION OF RESULTS

## 7.1. Formula and method of calculation

Plot the optical densities of the standards against their concentrations.

The ester content (expressed as ethyl acetate = A) corresponding to the absorbance value is read off on the graph and calculated according to the formula:

$$\frac{A \cdot 100}{T}$$

and given in 9 per hl ethanol at 100 % vol,

where T = alcohol content of the sample in % vol determination as described in method 1.

## 7.2. Repeatability

The difference between the results of two determinations, carried out simultaneously or in rapid succession, by the same analyst, on the same sample, under the same conditions, should not exceed 0,1 g esters, as ethyl acetate, per hl ethanol at 100 % vol.

**Method 8: Determination of volatile nitrogen bases**

## 1. SCOPE AND FIELD OF APPLICATION

The method determines volatile nitrogen bases, expressed as nitrogen, in neutral alcohol.

**▼M12**

## 2. DEFINITION

The volatile nitrogen bases content: the content of volatile nitrogen bases, expressed as nitrogen, as determined by the method specified.

## 3. PRINCIPLE

The sample is evaporated to a small volume in the presence of sulphuric acid and the ammonia content then determined using the conway micro-diffusion technique.

## 4. REAGENTS

4.1. Sulphuric acid, 1 mol/l.

4.2. Boric acid indicator solution. Dissolve 10 g of boric acid, 8 mg of bromocresol green and 4 mg of methyl red in 30 % vol propan-2-ol and make up to 1 000 ml with 30 % vol propan-2-ol.

4.3. Potassium hydroxide solution, 500 g/l; carbon dioxide free.

4.4. Hydrochloric acid, 0,02 mol/l.

## 5. APPARATUS

5.1. Evaporating dish, of sufficient capacity to accept 50 ml of sample.

5.2. Water bath.

5.3. Conway flask with tightly fitting lid; see figure 1 for description and suggested dimensions.

5.4. Micro-burette, capacity 2 to 5 ml, graduated in 0,01 ml.

## 6. PROCEDURE

6.1. Pipette 50 mls of the sample (with an anticipated nitrogen content of less than 0,2 g per hl sample take 200 ml of sample) into a glass dish, add 1 ml of 1 mol/l sulphuric acid (4.1), place the dish (5.1) on a water bath (5.2) and evaporate until there is about 1 ml remaining.

6.2. Pipette 1 ml of the boric acid indicator solution (4.2) into the inner chamber of the Conway flask (5.3) and wash the residue liquid from the evaporation process (6.1) into the outer chamber. Slightly tilt the Conway flask and add about 1 ml of the potassium hydroxide solution (4.3) to the outer chamber as quickly as possible but as far from the majority of the liquid in the outer chamber as possible. Immediately seal the Conway flask by covering with a tightly fitting lid smeared with grease.

6.3. Mix the two solutions in the outer chamber taking care that there is no liquid spillage from either chamber to the other. Allow to stand for two hours.

6.4. Titrate the ammonia in the inner chamber against 0,02 mol/l hydrochloric acid (4.4) using a micro-burette (5.4) to neutralisation. The volume of acid used should be between 0,2 and 0,9 ml; let the volume of acid used be  $V_1$  ml.

6.5. Carry out a blank titration by repeating sections 6.1 to 6.4 but replacing the 50 ml of sample in section 6.1 by the same volume of water. Let the volume of hydrochloric acid used be  $V_2$  ml.

## 7. EXPRESSION OF RESULTS

## 7.1. Formula and method of calculation.

The content of volatile nitrogen bases, in g per hl ethanol at 100 % vol, calculated and expressed as nitrogen, is given by:

$$\frac{(V_1 - V_0) \cdot 2800}{E \cdot T}$$

Where

$V_1$  = the volume, to ml, at the hydrochloric acid used to neutralize the sample.

$V_2$  = the volume, in ml, of hydrochloric acid used in the blank test.



▼ **M12**

T = the alcoholic strength by volume of the sample as determined by method 1.

E = the quantity of sample used in ml.

## 7.2. Repeatability

The difference between the results of two determinations, carried out simultaneously or in rapid succession, by the same analyst, on the same sample, under the same conditions, shall not exceed 0,05 g per hl ethanol at 100 % vol.

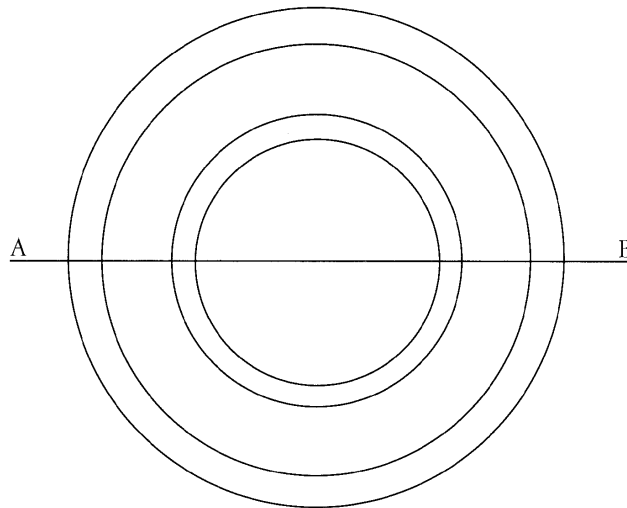

Top view of flask

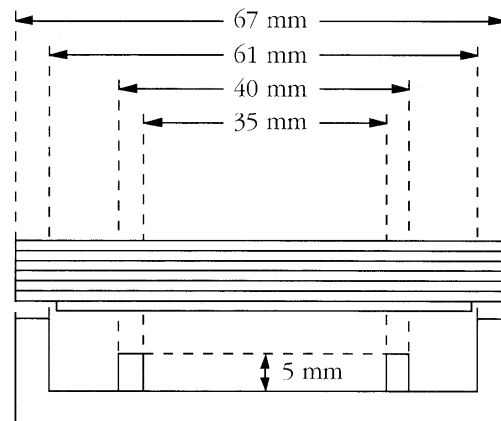

Vertical Section on line A - B

Typical dimension given

*Figure 1: Conway flask*

**Method 9: Determination of methanol**

1. SCOPE AND FIELD OF APPLICATION

The method determines the content of methanol in neutral alcohol.

2. DEFINITION

The methanol content: the content of methanol as determined by the method specified.

**▼ M12**

## 3. PRINCIPLE

The methanol concentration is determined by direct injection of sample into a gas liquid chromatography apparatus.

## 4. PROCEDURE

Any GLC method is suitable provided that the gas chromatographic column and conditions employed are capable of achieving a clear separation between methanol, acetaldehyde, ethanol and ethyl acetate. The limit of detection of methanol in ethanol shall be less than 2 g/hl.

## 5. REPEATABILITY

The difference between the results of two determinations, carried out simultaneously or in rapid succession, by the same analyst, on the same sample, under the same conditions, shall not exceed 2 g methanol per hl ethanol at 100 % vol.

**Method 10: Determination of dry residue**

## 1. SCOPE AND FIELD OF APPLICATION

The method determines the dry residue content of neutral alcohol.

## 2. DEFINITION

The dry residue content: the dry matter content as determined by the method specified.

## 3. PRINCIPLE

An aliquot of the sample is dried at 103 °C and the residue determined gravimetrically.

## 4. APPARATUS

- 4.1. Water bath, boiling.
- 4.2. Evaporating dish of suitable capacity.
- 4.3. Desiccator, containing freshly activated silica gel (or an equivalent desiccant) with a moisture content indicator.
- 4.4. Analytical balance.
- 4.5. Oven, thermostatically controlled at  $103 \pm 2$  °C.

## 5. PROCEDURE

Accurately weigh, to the nearest 0,1 mg, a clean dry evaporating dish (4.2) ( $m_0$ ). Pipette in several operations if necessary a suitable volume of sample into the dish (100 — 250 ml) ( $V_0$ ml). Place the dish with sample on the boiling water bath (4.1) and allow to dry. Place in the oven (4.5) at  $103 \pm 2$  °C for 30 minutes and then transfer dish with residue into a desiccator (4.3). Allow the dish to cool for 30 minutes and then weigh, to the nearest 0,1 mg, the dish with residue ( $M_1$ ).

## 6. EXPRESSION OF RESULTS

## 6.1. Formula and method of calculation

The content of dry residue, to g per hl of ethanol at 100 % vol is given by:

$$\frac{(M_1 - M_0) \cdot 10^7}{V_0 \cdot T}$$

where:

$M_0$  = the mass, in g, of the clean dry dish,

$M_1$  = the mass, in g, of the dish and residue after drying,

$V_0$  = the volume of sample taken for drying, and

$T$  = the alcohols strength by volume of the sample as determined by method 1.

**▼ M12**

## 6.2. Repeatability

The difference between the results of two determinations, carried out simultaneously or in rapid succession, by the same analyst, on the same sample, under the same conditions, shall not exceed 0,5 g per hl of ethanol at 100 % vol.

**Method 11: Limit test for the absence of furfural**

## 1. SCOPE AND FIELD OF APPLICATION

The method detects furfural in neutral alcohol.

## 2. DEFINITION

The detection of the limit tests concentration of furfural: the limit test result as determined by the method specified.

## 3. PRINCIPLE

The alcohol sample is mixed with aniline and glacial acetic acid. The presence of furfural is indicated by a salmon pink colour appearing in the solution within 20 minutes of mixing.

## 4. REAGENTS

## 4.1. Aniline, freshly distilled.

## 4.2. Acetic acid, glacial.

## 5. APPARATUS

Tubes, fitted with ground glass stoppers.

## 6. PROCEDURE

Pipette 10 ml of the sample into a tube (5); add 0,5 ml of aniline and 2 ml of glacial acetic acid. Shake the tube and contents to mix.

## 7. EXPRESSION OF RESULTS

## 7.1. Limit test interpretation

If the time of development of any salmon pink colouration in the tube is less than 20 minutes the test is positive and the sample contains furfural.

## 7.2. Observations

The results of two limit tests, carried out simultaneously or in rapid succession, by the same analyst, on the same sample, under the same conditions, shall be identical.

**Method 12: UV test**

## 1. SCOPE

This method determines the optical transparence of neutral alcohol.

## 2. PRINCIPLE

The optical transparence of the sample in the wavelength range 220 to 270 nm is measured against a defined reference substance of high optical transparence.

## 3. APPARATUS

## 3.1. UV-VIS spectrophotometer

## 3.2. Quartz cuvettes, 10 mn path length, same spectrum transmission.

## 4. REAGENTS

n-Hexane for spectroscopy.

## 5. PROCEDURE

— Rinse clean cuvettes with sample solution and then pour in the sample; dry the outside of the cuvettes,

— treat reference cuvette in the same way with n-Hexane and fill,

— determine absorbance values and construct graph.

▼ **M12**

## 6. EXPRESSION OF RESULTS

The absorbance values found at 270, 240, 230 and 220 nm may not exceed the following figures: 0,02, 0,08, 0,18 and 0,3.

The absorbance curve must be smooth and regular.

**Method 13: Determination of <sup>14</sup>C content in ethanol**

## 1. METHOD TO DETERMINE TYPE OF ALCOHOL

Determination of the <sup>14</sup>C content in ethanol permits a distinction to be made between alcohol from fossil fuels (synthesis alcohol) and alcohol from recent raw materials (fermentation alcohol).

## 2. DEFINITION

The <sup>14</sup>C content of ethanol is understood to be the <sup>14</sup>C content determined using the method described here.

The natural <sup>14</sup>C content in the atmosphere (the reference value), which is absorbed by living vegetation by assimilation, is not a constant value. The reference value is therefore determined on ethanol from raw materials of the most recent vegetation period. This annual reference value is determined each year by collaborative analyses organised by the Community Bureau of References and the Joint Research Centre, Ispra

## 3. PRINCIPLE

The <sup>14</sup>C content of samples containing alcohol with at least 85 % mass ethanol is determined directly by liquid scintillation count.

## 4. REAGENTS

## 4.1. Toluene scintillator

5,0 g 2,5-diphenyloxazole (PPO)

0,5 g p-bis-[4-methyl-5-phenyloxazolyl(2)]-benzene (dimethyl-POPOP) in 1 litre analytical grade toluene.

Commercial, ready-to-use toluene scintillators of this composition can also be used.

4.2. <sup>14</sup>C standard

n-Hexadecane <sup>14</sup>C with an activity of about  $1 \times 10^6$  dpm/g (approximately  $1,67 \times 10^6$  cBq/g) and a guaranteed accuracy of determined activity of  $\pm 2$  % rel.

4.3. <sup>14</sup>C-free ethanol

Synthesis alcohol from raw materials of fossil origin with at least 85 % mass ethanol, to determine the background.

## 4.4. Alcohol from recent raw materials of the most recent vegetation period with at least 85 % mass ethanol as reference material.

## 5. APPARATUS

## 5.1. Multi-channel liquid scintillation spectrometer with processor and automatic external standardisation and display of the external standard/channel ratio (usual design: three meter channels and two external standard channels).

## 5.2. Low-potassium counter tubes suitable for the spectrometer, with dark screw-tops containing a polyethylene insert.

## 5.3. Volumetric pipettes, 10 ml.

## 5.4. Automatic dosing device 10 ml.

## 5.5. 250 ml round-bottom flask with ground-glass stopper.

## 5.6. Alcohol distillation apparatus with heating mantle, e.g. type Micko.

5.7. Microliter syringe 50  $\mu$ l.

## 5.8. Pycnometer funnel, pycnometers, 25 ml and 50 ml.

5.9. Thermostat with a temperature stability of  $\pm 0,01$  °C.

▼ M12

- 5.10. Official alcohol tables in accordance with the Council Directive of 27 July 1976 on the approximation of the laws of Member States relating to alcohol tables, published by the Commission of the European Communities (ISBN 92-825-0146-9).

## 6. PROCEDURE

## 6.1. Adjusting the equipment

The equipment should be adjusted according to the manufacturer's instructions. Measuring conditions are optimal when the value  $E_2/B$ , the quality index, is at its maximum.

E = efficiency

B = background

Only two meter channels are optimised. The third is left fully open for control purposes.

## 6.2. Selection of counter tubes

A larger number of counter tubes than will later be needed are each filled with 10 ml of  $^{14}\text{C}$ -free synthesis ethanol and 10 ml toluene scintillator. Each is measured for at least  $\times 100$  minutes. Tubes whose backgrounds vary by more than  $\pm 1$  % rel. from the mean are discarded. Only tubes new from the factory and from the same batch may be used.

## 6.3. Determination of the external standard/channel ratio (ESCR)

During the process of setting the channels (6.1) the ESCR is determined using the appropriate computer program when the efficiency is determined. The external standard used is  $^{137}\text{caesium}$ , which is already built-in by the manufacturer.

## 6.4. Preparation of sample

Samples having an ethanol content of at least 85 % mass and free from impurities, which absorb at wavelengths below 450 nm can be measured. The low residue of esters and aldehydes is not a problem. After the first few ml have been discarded the sample is distilled direct into the pycnometer and the alcohol content of the sample is determined by pycnometry. The values to be determined are taken from the Official Alcohol Tables.

## 7. MEASUREMENT OF SAMPLES USING EXTERNAL STANDARD

- 7.1. Slightly extinguished samples such as those described in 6.4 with an ESCR of around 1.8 may be measured via the ESCR, which provides a measure of the efficiency.

## 7.2. Measurement

10 ml each of the samples prepared according to 6.4 is pipettes into a selected counter tube checked for background and 10 ml of toluene scintillator is added via an automatic dosing device. The samples in the tubes are homogenised by suitable rotary movements; the liquid must not be allowed to wet the polyethylene insert in the screw-top. A tube containing  $^{14}\text{C}$ -free fossil ethanol is prepared in the same way to measure the background. To check the relevant annual  $^{14}\text{C}$  value a duplicate of recent ethanol from the latest vegetation period is prepared, a tube being mixed with internal standard, see 8.

The control and background samples are placed at the beginning of the measurement series, which should contain no more than 10 samples for analysis. Total measuring time per sample is at least  $2 \times 100$  minutes, with the individual samples being measured in part stages of 100 minutes so that any equipment drift or other defect can be detected. (One cycle therefore corresponds to a measuring interval of 100 minutes per sample).

Background and control samples should be freshly prepared every four weeks.

This method requires little time and material and is particularly suitable for non-specialist laboratories processing large numbers of samples.

▼ **M12**

In the case of slightly extinguished samples (ESCR circa 1,8) the efficiency is only negligibly affected by the change in this value. If the change is within  $\pm 5\%$  rel. the same efficiency can be expected. For more greatly extinguished samples, such as denatured alcohols, the efficiency can be established via the extinction correction graph. If an appropriate computer program is not available the internal standard must be used, and this gives an unambiguous result.

## 8. MEASURING SAMPLES USING INTERNAL STANDARD HEXADECANE<sup>14</sup>C

### 8.1. Procedure

Control and background samples (recent and fossil ethanol) and the unknown material are each measured as duplicates. One sample of the duplicate is prepared in a non-selected tube and an accurately dosed quantity (30  $\mu$ l) of hexadecane<sup>14</sup>C is added as internal standard (added activity around 26 269 dpm/gC approximately 43 782 cBq/gC). For the sample preparation and measuring time of the other samples see 7.2, but the measuring time for the samples with the internal standard can be reduced to about five minutes by presetting at  $10^5$  pulses. One duplicate each of background and control samples is used per measuring series; these are placed at the beginning of the measuring series.

### 8.2. Handling the internal standard and counter tubes

To prevent contamination when measuring with the internal standard these must be stored and handled well away from the area where the samples for analysis are prepared and measured. After measurement the tubes checked for background may be re-used. The screw-tops and tubes containing the internal standard are disposed of.

## 9. EXPRESSION OF THE RESULTS

### 9.1. The unit of activity of a radio-active substance is the becquerel; 1 Bq = 1 decay/sec.

Indication of specific radio-activity is expressed as becquerels relative to one gram carbon = Bq/gC.

To obtain more practical results it is best to express the results in centi-bequerels = cBq/gC.

The descriptions and formulae used in the literature, based on dpm, may be retained for the time being. To obtain corresponding figures in cBq merely multiply the dpm figure by 100/60.

### 9.2. Expression of results with external standard

$$\text{cBq/g C} = \frac{(\text{cpm}_{\text{pr}} - \text{cpm}_{\text{NE}}) \cdot 1,918 \cdot 100}{V \cdot F \cdot Z \cdot 60}$$

### 9.3. Expression of results with internal standard

$$\text{cBq/g C} = \frac{(\text{cpm}_{\text{pr}} - \text{cpm}_{\text{NE}}) \cdot \text{dpm}_{\text{IS}} \cdot 1,918 \cdot 100}{(\text{cpm}_{\text{IS}} - \text{cpm}_{\text{pr}}) \cdot V \cdot F \cdot 60}$$

### 9.4. Abbreviations

$\text{cpm}_{\text{pr}}$  = the mean sample count rate over the total measuring time.

$\text{cpm}_{\text{NE}}$  = the mean background pulse rate calculated in the same way.

$\text{cpm}_{\text{IS}}$  = the amount of added internal standard added (calibration radioactivity dpm).

$\text{dpm}_{\text{IS}}$  = the quantity of internal standard added (calibration radio-activity dpm).

V = the volume of the samples used in ml.

F = the content in grammes pure alcohol per ml corresponding to its concentration.

Z = the efficiency corresponding to the ESCR value.

1,918 = the number of grammes alcohol per gramme carbon.

**▼M12**

## 10. RELIABILITY OF THE METHOD

## 10.1. Repeatability (r)

$$r = 0,632 \text{ cBq/g C}; S_{(r)} = \pm 0,223 \text{ cBq/g C}$$

## 10.2. Comparability (R)

$$R = 0,821 \text{ cBq/g C}; S_{(R)} = \pm 0,290 \text{ cBq/g C}.$$

