

Directive 2004/26/EC of the European Parliament and of the Council of 21 April 2004 amending Directive 97/68/EC on the approximation of the laws of the Member States relating to measures against the emission of gaseous and particulate pollutants from internal combustion engines to be installed in non-road mobile machinery (Text with EEA relevance)

DIRECTIVE 2004/26/EC OF THE EUROPEAN
PARLIAMENT AND OF THE COUNCIL

of 21 April 2004

amending Directive 97/68/EC on the approximation of the laws of the Member States relating to measures against the emission of gaseous and particulate pollutants from internal combustion engines to be installed in non-road mobile machinery

(Text with EEA relevance)

THE EUROPEAN PARLIAMENT AND THE COUNCIL OF THE EUROPEAN UNION,

Having regard to the Treaty establishing the European Community, and in particular Article 95 thereof,

Having regard to the proposal from the Commission⁽¹⁾,

Having regard to the Opinion of the European Economic and Social Committee⁽²⁾,

Acting in accordance with the procedure laid down in Article 251 of the Treaty⁽³⁾,

Whereas:

- (1) Directive 97/68/EC⁽⁴⁾ implements two stages of emission limit values for compression ignition engines and calls on the Commission to propose a further reduction in emission limits, taking into account the global availability of techniques for controlling air polluting emissions from compression ignition engines and the air quality situation.
- (2) The Auto-Oil programme concluded that further measures are needed to improve the future air quality of the Community, especially as regards ozone formation and emissions of particulate matter.
- (3) Advanced technology to reduce emissions from compression ignition engines on on-road vehicles is already available to a large extent and such technology should, to a large extent, be applicable to the non-road sector.
- (4) There are still some uncertainties regarding the cost effectiveness of using after-treatment equipment to reduce emissions of particulate matter (PM) and of oxides of nitrogen (NO_x). A technical review should be carried out before 31 December 2007 and, where appropriate, exemptions or delayed dates of entry into force should be considered.

Status: EU Directives are being published on this site to aid cross referencing from UK legislation. After IP completion day (31 December 2020 11pm) no further amendments will be applied to this version.

- (5) A transient test procedure is needed to cover the operational conditions used by this kind of machinery under real working conditions. The test should therefore include, in an appropriate proportion, emissions from an engine that is not warmed up.
- (6) Under randomly selected load conditions and within a defined operating range, the limit values should not be exceeded by more than an appropriate percentage.
- (7) Moreover, the use of defeat devices and irrational emission control strategies should be prevented
- (8) The proposed package of limit values should be aligned as far as possible on developments in the United States so as to offer manufacturers a global market for their engine concepts.
- (9) Emission standards should also be applied for railway and inland waterway applications to help promote them as environmentally friendly modes of transport.
- (10) Where non-road mobile machinery complies with future limit values ahead of the deadline, it should be possible to indicate that it does so.
- (11) Because of the technology needed to meet the Stage III B and IV limits for PM and NOx emissions, the sulphur content of the fuel must be reduced from today's levels in many Member States. A reference fuel that reflects the fuel market situation should be defined.
- (12) Emission performance during the full useful life of the engines is of importance. Durability requirements should be introduced to avoid deterioration of emission performance.
- (13) It is necessary to introduce special arrangements for equipment manufacturers to give them time to design their products and to handle small series production.
- (14) Since the objective of this Directive, namely improvement of the future air quality situation, cannot be sufficiently achieved by the Member States since the necessary emission limitations concerning products have to be regulated at Community level, the Community may adopt measures, in accordance with the principle of subsidiarity as set out in Article 5 of the Treaty. In accordance with the principle of proportionality, as set out in that Article, this Directive does not go beyond what is necessary in order to achieve that objective.
- (15) Directive 97/68/EC should therefore be amended accordingly,

HAVE ADOPTED THIS DIRECTIVE:

Article 1

Directive 97/68/EC is amended as follows:

- 1) the following indents shall be added to Article 2:
 - "inland waterway vessel" shall mean a vessel intended for use on inland waterways having a length of 20 metres or more and having a volume of 100 m³ or more according to the formula defined in Annex I, Section 2, point

Status: EU Directives are being published on this site to aid cross referencing from UK legislation. After IP completion day (31 December 2020 11pm) no further amendments will be applied to this version.

2.8a, or tugs or pusher craft having been built to tow or to push or to move alongside vessels of 20 metres or more,

This definition does not include:

- vessels intended for passenger transport carrying no more than 12 people in addition to the crew,
- recreational craft with a length of less than 24 metres (as defined in Article 1(2) of Directive 94/25/EC of the European Parliament and of the Council of 16 June 1994 on the approximation of the laws, regulations and administrative provisions of the Member States relating to recreational craft⁽⁵⁾),
- service craft belonging to supervisory authorities,
- fire-service vessels,
- naval vessels,
- fishing vessels on the fishing vessels register of the Community,
- sea-going vessels, including sea-going tugs and pusher craft operating or based on tidal waters or temporarily on inland waterways, provided that they carry a valid navigation or safety certificate as defined in Annex I, Section 2, point 2.8b.
- "Original equipment manufacturer (OEM)" shall mean a manufacturer of a type of non-road mobile machine,
- "Flexibility scheme" shall mean the procedure allowing an engine manufacturer to place on the market, during the period between two successive stages of limit values, a limited number of engines, to be installed in non-road mobile machinery, that only comply with the previous stage of emission limit values.

2) Article 4 shall be amended as follows:

(a) The following text shall be added at the end of paragraph 2:

Annex VIII shall be amended in accordance with the procedure referred to in Article 15 .

(b) The following paragraph shall be added:

6. Compression ignition engines for use other than in propulsion of locomotives, railcars and inland waterway vessels may be placed on the market under a flexible scheme in accordance with the procedure referred to in Annex XIII in addition to paragraphs 1 to 5.

3) In Article 6 the following paragraph shall be added:

5. Compression ignition engines placed on the market under a "flexible scheme" shall be labelled in accordance with Annex XIII.

4) The following Article shall be inserted after Article 7:

Status: EU Directives are being published on this site to aid cross referencing from UK legislation. After IP completion day (31 December 2020 11pm) no further amendments will be applied to this version.

Article 7a

Inland waterway vessels

- 1 The following provisions shall apply to engines to be installed in inland waterway vessels. Paragraphs 2 and 3 shall not apply until the equivalence between the requirements established by this Directive and those established in the framework of the Mannheim Convention for the Navigation of the Rhine is recognised by the Central Commission of Navigation on Rhine (hereinafter: CCNR) and the Commission is informed thereof.
- 2 Until 30 June 2007, Member States may not refuse the placing on the market of engines which meet the requirements established by CCNR stage I, the emission limit values for which are set out in Annex XIV.
- 3 As from 1 July 2007 and until the entry into force of a further set of limit values which would result from further amendments to this Directive, Member States may not refuse the placing on the market of engines which meet the requirements established by CCNR stage II, the emission limit values for which are set out in Annex XV.
- 4 In accordance with the procedure referred to in Article 15, Annex VII shall be adapted to integrate the additional and specific information which may be required as regards the type approval certificate for engines to be installed in inland waterway vessels.
- 5 For the purposes of this Directive, as far as inland waterway vessels are concerned, any auxiliary engine with a power of more than 560 kW shall be subject to the same requirements as propulsion engines.
- (5) Article 8 shall be amended as follows:
- (a) The title shall be replaced by "Placing on the market":
 - (b) Paragraph 1 shall be replaced by the following:
 - 1. Member States may not refuse the placing on the market of engines, whether or not already installed in machinery, which meet the requirements of this Directive.
 - (c) The following paragraph shall be inserted after paragraph 2:
 - 2a. Member States shall not issue the Community Inland Water Navigation certificate established by Council Directive 82/714/EC of 4 October 1982 laying down technical requirements for inland waterway vessels⁽⁶⁾ to any vessels whose engines do not meet the requirements of this Directive.
- 6) Article 9 shall be amended as follows:
- (a) The introductory phrase of paragraph 3 shall be replaced by the following:

Member States shall refuse to grant type-approval for an engine type or engine family and to issue the document as described in Annex VII and shall refuse to grant any other type-approval for non-road mobile

Status: EU Directives are being published on this site to aid cross referencing from UK legislation. After IP completion day (31 December 2020 11pm) no further amendments will be applied to this version.

machinery, in which an engine, not already placed on the market, is installed.

(b) The following paragraphs shall be inserted after paragraph 3:

3a. TYPE-APPROVAL OF STAGE IIIA ENGINES (ENGINE CATEGORIES H, I, J and K)

Member States shall refuse to grant type-approval for the following engine types or families and to issue the document as described in Annex VII, and shall refuse to grant any other type-approval for non-road mobile machinery in which an engine, not already placed on the market, is installed:

- H: after 30 June 2005 for engines - other than constant speed engines - of a power output: $130 \text{ kW} \leq P \leq 560 \text{ kW}$,
- I: after 31 December 2005 for engines — other than constant speed engines — of a power output: $75 \text{ kW} \leq P < 130 \text{ kW}$,
- J: after 31 December 2006 for engines — other than constant speed engines — of a power output: $37 \text{ kW} \leq P < 75 \text{ kW}$,
- K: after 31 December 2005 for engines — other than constant speed engines — of a power output: $19 \text{ kW} \leq P < 37 \text{ kW}$,

where the engine fails to meet the requirements specified in this Directive and where the emissions of particulate and gaseous pollutants from the engine do not comply with the limit values as set out in the table in section 4.1.2.4. of Annex I.

3b. TYPE-APPROVAL OF STAGE IIIA CONSTANT SPEED ENGINES (ENGINE CATEGORIES H, I, J and K)

Member States shall refuse to grant type-approval for the following engine types or families and to issue the document as described in Annex VII, and shall refuse to grant any other type-approval for non-road mobile machinery in which an engine, not already placed on the market, is installed:

- Constant speed H engines: after 31 December 2009 for engines of a power output: $130 \text{ kW} \leq P < 560 \text{ kW}$,
- Constant speed I engines: after 31 December 2009 for engines of a power output: $75 \text{ kW} \leq P < 130 \text{ kW}$,
- Constant speed J engines: after 31 December 2010 for engines of a power output: $37 \text{ kW} \leq P < 75 \text{ kW}$,
- Constant speed K engines: after 31 December 2009 for engines of a power output: $19 \text{ kW} \leq P < 37 \text{ kW}$,

where the engine fails to meet the requirements specified in this Directive and where the emissions of particulate and gaseous pollutants from the engine do not comply with the limit values set out in the table in Section 4.1.2.4. of Annex I.

3c. TYPE-APPROVAL OF STAGE III B ENGINES (ENGINE CATEGORIES L, M, N and P)

Member States shall refuse to grant type-approval for the following engine types or families and to issue the document as described in Annex VII, and shall refuse to grant any other type-approval for non-road mobile machinery in which an engine, not already placed on the market, is installed:

Status: EU Directives are being published on this site to aid cross referencing from UK legislation. After IP completion day (31 December 2020 11pm) no further amendments will be applied to this version.

- L: after 31 December 2009 for engines — other than constant speed engines — of a power output: $130 \text{ kW} \leq P < 560 \text{ kW}$,
- M: after 31 December 2010 for engines — other than constant speed engines — of a power output: $75 \text{ kW} \leq P < 130 \text{ kW}$,
- N: after 31 December 2010 for engines — other than constant speed engines — of a power output: $56 \text{ kW} \leq P < 75 \text{ kW}$,
- P: after 31 December 2011 for engines — other than constant speed engines — of a power output: $37 \text{ kW} \leq P < 56 \text{ kW}$,

where the engine fails to meet the requirements specified in this Directive and where the emissions of particulate and gaseous pollutants from the engine do not comply with the limit values set out in the table in Section 4.1.2.5. of Annex I.

3d. TYPE-APPROVAL OF STAGE IV ENGINES (ENGINE CATEGORIES Q and R)

Member States shall refuse to grant type-approval for the following engine types or families and to issue the document as described in Annex VII, and shall refuse to grant any other type-approval for non-road mobile machinery in which an engine, not already placed on the market, is installed:

- Q: after 31 December 2012 for engines — other than constant speed engines — of a power output: $130 \text{ kW} \leq P \leq 560 \text{ kW}$,
- R: after 30 September 2013 for engines — other than constant speed engines — of a power output: $56 \text{ kW} \leq P < 130 \text{ kW}$,

where the engine fails to meet the requirements specified in this Directive and where the emissions of particulate and gaseous pollutants from the engine do not comply with the limit values set out in the table in Section 4.1.2.6. of Annex I.

3e. TYPE-APPROVAL OF STAGE III A PROPULSION ENGINES USED IN INLAND WATERWAY VESSELS (ENGINE CATEGORIES V)

Member States shall refuse to grant type-approval for the following engine types or families and to issue the document as described in Annex VII:

VI:1: after 31 December 2005 for engines of power output at or above 37 kW and swept volume below 0.9 litres per cylinder,

VI:2: after 30 June 2005 for engines with swept volume at or above 0.9 but below 1.2 litres per cylinder,

VI:3: after 30 June 2005 for engines with swept volume at or above 1.2 but below 2.5 litres per cylinder and an engine power output of: $37 \text{ kW} \leq P < 75 \text{ kW}$,

VI:4: after 31 December 2006 for engines with swept volume at or above 2.5 but below 5 litres per cylinder,

V2: after 31 December 2007 for engines with swept volume at or above 5 litres per cylinder,

where the engine fails to meet the requirements specified in this Directive and where the emissions of particulate and gaseous pollutants from the

Status: EU Directives are being published on this site to aid cross referencing from UK legislation. After IP completion day (31 December 2020 11pm) no further amendments will be applied to this version.

engine do not comply with the limit values as set out in the table in section 4.1.2.4 of Annex I.

3f. TYPE-APPROVAL OF STAGE III A PROPULSION ENGINES USED IN RAILCARS

Member States shall refuse to grant type-approval for the following engine types or families and to issue the document as described in Annex VII:

— RC A: after 30 June 2005 for engines of power output above 130 kW

where the engine fails to meet the requirements specified in this Directive and where the emissions of particulate and gaseous pollutants from the engine do not comply with the limit values as set out in the table in section 4.1.2.4 of Annex I.

3g. TYPE-APPROVAL OF STAGE III B PROPULSION ENGINES USED IN RAILCARS

Member States shall refuse to grant type-approval for the following engine types or families and to issue the document as described in Annex VII:

— RC B: after 31 December 2010 for engines of power output above 130 kW

where the engine fails to meet the requirements specified in this Directive and where the emissions of particulate and gaseous pollutants from the engine do not comply with the limit values as set out in the table in section 4.1.2.5 of Annex I.

3h. TYPE-APPROVAL OF STAGE III A PROPULSION ENGINES USED IN LOCOMOTIVES

Member States shall refuse to grant type-approval for the following engine types or families and to issue the document as described in Annex VII:

— RL A: after 31 December 2005 for engines of power output: $130 \text{ kW} \leq P \leq 560 \text{ kW}$

— RH A: after 31 December 2007 for engines of power output: $560 \text{ kW} < P$

where the engine fails to meet the requirements specified in this Directive and where the emissions of particulate and gaseous pollutants from the engine do not comply with the limit values as set out in the table in section 4.1.2.4 of Annex I. The provisions of this paragraph shall not apply to the engine types and families referred to where a contract has been entered into to purchase the engine before ...⁽⁷⁾ and provided that the engine is placed on the market no later than two years after the applicable date for the relevant category of locomotive.

3i. TYPE-APPROVAL OF STAGE III B PROPULSION ENGINES USED IN LOCOMOTIVES

Member States shall refuse to grant type-approval for the following engine types or families and to issue the document as described in Annex VII:

— R B: after 31 December 2010 for engines of power output above 130 kW

Status: EU Directives are being published on this site to aid cross referencing from UK legislation. After IP completion day (31 December 2020 11pm) no further amendments will be applied to this version.

where the engine fails to meet the requirements specified in this Directive and where the emissions of particulate and gaseous pollutants from the engine do not comply with the limit values as set out in the table in section 4.1.2.5 of Annex I. The provisions of this paragraph shall not apply to the engine types and families referred to where a contract has been entered into to purchase the engine before ...⁽⁷⁾ and provided that the engine is placed on the market no later than two years after the applicable date for the relevant category of locomotives.

- (c) The title of paragraph 4 shall be replaced by the following:

PLACING ON THE MARKET: ENGINE PRODUCTION DATES

- (d) The following paragraph shall be inserted:

- 4a. Without prejudice to Article 7a and to Article 9 (3g) and (3h), after the dates referred to hereafter, with the exception of machinery and engines intended for export to third countries, Member States shall permit the placing on the market of engines, whether or not already installed in machinery, only if they meet the requirements of this Directive, and only if the engine is approved in compliance with one of the categories as defined in paragraphs 2 and 3.

Stage III A other than constant speed engines

- category H: 31 December 2005
- category I: 31 December 2006
- category J: 31 December 2007
- category K: 31 December 2006

Stage III A inland waterway vessel engines

- category V 1: 1: 31 December 2006
- category V 1:2: 31 December 2006
- category V 1:3: 31 December 2006
- category V1:4: 31 December 2008
- categories V2: 31 December 2008.

Stage III A constant speed engines

- category H: 31 December 2010
- category I: 31 December 2010
- category J: 31 December 2011
- category K: 31 December 2010

Stage III A railcar engines

- category RC A: 31 December 2005

Stage III A locomotive engines

- category RL A: 31 December 2006
- category RH A: 31 December 2008

Stage III B other than constant speed engines

- category L: 31 December 2010

Status: EU Directives are being published on this site to aid cross referencing from UK legislation. After IP completion day (31 December 2020 11pm) no further amendments will be applied to this version.

- category M: 31 December 2011
- category N: 31 December 2011
- category P: 31 December 2012

Stage III B railcar engines

- category RC B: 31 December 2011

Stage III B locomotive engines

- category R B: 31 December 2011

Stage IV other than constant speed engines

- category Q: 31 December 2013
- category R: 30 September 2014

For each category, the above requirements shall be postponed by two years in respect of engines with a production date prior to the said date.

The permission granted for one stage of emission limit values shall be terminated with effect from the mandatory implementation of the next stage of limit values.

- (e) The following paragraph shall be added:

- 4b. Labelling to indicate early compliance with the standards of stages IIIA, IIIB and IV

For engine types or engine families meeting the limit values set out in the table in section 4.1.2.4, 4.1.2.5 and 4.1.2.6 of Annex I before the dates laid down in paragraph 4 of this Article, Member States shall allow special labelling and marking to show that the equipment concerned meets the required limit values before the dates laid down.

- (7) Article 10 shall be amended as follows:

- (a) Paragraphs 1 and 1 a shall be replaced by the following:

1. The requirements of Article 8(1) and (2), Article 9(4) and Article 9a (5) shall not apply to:
 - engines for use by the armed services,
 - engines exempted in accordance with paragraphs 1a and 2,
 - engines for use in machines intended primarily for the launch and recovery of lifeboats,
 - engines for use in machines intended primarily for the launch and recovery of beach launched vessels.
- 1a. Without prejudice to Article 7a and to Article 9(3g) and (3h), replacement engines, except for railcar, locomotive and inland waterway vessel propulsion engines, shall comply with the limit values that the engine to be replaced had to meet when originally placed on the market.

The text "REPLACEMENT ENGINE" shall be attached to a label on the engine or inserted into the owner's manual.

- (b) The following paragraphs shall be added:

Status: EU Directives are being published on this site to aid cross referencing from UK legislation. After IP completion day (31 December 2020 11pm) no further amendments will be applied to this version.

5. Engines may be placed on the market under a "flexible scheme" in accordance with the provisions in Annex XIII.
 6. Paragraph 2 shall not apply to propulsion engines to be installed in inland waterway vessels.
 7. Member States shall permit the placing on the market of engines, as defined under A(i) and A(ii) of Annex I, under the "flexibility scheme" in accordance with the provisions in Annex XIII.
- 8) The Annexes shall be amended as follows:
- (a) Annexes I, III, V, VII and XII shall be amended in accordance with Annex I to this Directive;
 - (b) Annex VI shall be replaced by the text in Annex II to this Directive;
 - (c) A new Annex XIII as set out in Annex III to this Directive shall be added;
 - (d) A new Annex XIV as set out in Annex IV to this Directive shall be added;
 - (e) A new Annex XV as set out in Annex IV to this Directive shall be added;
- and the list of the existing Annexes shall be amended accordingly.

Article 2

The Commission shall, not later than 31 December 2007:

- (a) re-assess its non-road emission inventory estimates and specifically examine potential cross-checks and correction factors;
- (b) consider the available technology, including the cost/benefits, with a view to confirming Stage III B and IV limit values and evaluating the possible need for additional flexibilities, exemptions or later introduction dates for certain types of equipment or engines and taking into account engines installed in non-road mobile machinery used in seasonal applications;
- (c) evaluate the application of test cycles for engines in railcars and locomotives and, in the case of engines in locomotives, the cost and benefits of a further reduction of emission limit values in view of the application of NO_x after-treatment technology;
- (d) consider the need to introduce a further set of limit values for engines to be used in inland waterway vessels taking into account in particular the technical and economic feasibility of secondary abatement options in this application;
- (e) consider the need to introduce emission limit values for engines below 19 kW and above 560 kW;
- (f) consider the availability of fuels required by the technologies used to meet the Stage IIIB and IV standards levels;
- (g) consider the engine operating conditions under which the maximum permissible percentages by which the emission limit values laid down in Section 4.1.2.5 and 4.1.2.6 of Annex I may be exceeded and present proposals as appropriate to technically adapt the Directive in accordance with the procedure referred to in Article 15 of Directive 97/68/EC;

Status: EU Directives are being published on this site to aid cross referencing from UK legislation. After IP completion day (31 December 2020 11pm) no further amendments will be applied to this version.

- (h) assess the need for a system for "in-use compliance" and examine possible options for its implementation;
 - (i) consider detailed rules to prevent "cycle beating" and cycle by-pass;
- and submit, where appropriate, proposals to the European Parliament and the Council.

Article 3

1 Member States shall bring into force the laws, regulations and administrative provisions necessary to comply with this Directive by ...⁽⁸⁾. They shall forthwith inform the Commission thereof.

When Member States adopt those measures, they shall contain a reference to this Directive or shall be accompanied by such a reference on the occasion of their official publication. The methods of making such reference shall be laid down by Member States.

2 Member States shall communicate to the Commission the text of the main provisions of national law which they adopt in the field covered by this Directive.

Article 4

Member States shall determine the sanctions applicable to breaches of the national provisions adopted pursuant to this Directive and shall take all necessary measures for their implementation. The sanctions determined must be effective, proportionate and dissuasive. Member States shall notify these provisions to the Commission by ...⁽⁹⁾, and shall notify any subsequent modifications thereof as soon as possible.

Article 5

This Directive shall enter into force on the twentieth day following that of its publication in the Official Journal of the European Union.

Article 6

This Directive is addressed to the Member States.

Done at Strasbourg, 21 April 2004

For the European Parliament

The President

P. COX

For the Council

The President

D. ROCHE

Status: EU Directives are being published on this site to aid cross referencing from UK legislation. After IP completion day (31 December 2020 11pm) no further amendments will be applied to this version.

ANNEX I

1. ANNEX I SHALL BE AMENDED AS FOLLOWS:
 - 1) SECTION 1 SHALL BE AMENDED AS FOLLOWS:
 - (a) Point A shall be replaced by the following:
 - A. intended and suited, to move, or to be moved with or without road, and with
 - (i) a C.I. engine having a net power in accordance with section 2.4 that is higher than or equal to 19 kW but not more than 560 kW and that is operated under intermittent speed rather than a single constant speed;
 - or
 - (ii) a C.I. engine having a net power in accordance with section 2.4 that is higher than or equal to 19 kW but not more than 560 kW and that is operated under constant speed. Limits only apply from 31 December 2006;
 - or
 - (iii) a petrol fuelled S.I. engine having a net power in accordance with section 2.4 of not more than 19 kW;
 - or
 - (iv) engines designed for the propulsion of railcars, which are self propelled on-track vehicles specifically designed to carry goods and/or passengers;
 - or
 - (v) engines designed for the propulsion of locomotives which are self-propelled pieces of on-track equipment designed for moving or propelling cars that are designed to carry freight, passengers and other equipment, but which themselves are not designed or intended to carry freight, passengers (other than those operating the locomotive) or other equipment. Any auxiliary engine or engine intended to power equipment designed to perform maintenance or construction work on the tracks is not classified under this paragraph but under A(i).;
 - (b) Point B shall be replaced by the following:

"B. Ships, except vessels intended for use on inland waterways;
 - (c) Point C shall be deleted
 - 2) Section 2 shall be amended as follows:
 - (a) The following shall be inserted:

2.8a: *volume of 100m³ or more* with regard to a vessel intended for use on inland waterways means its volume calculated on the formula

LxBxT, "L" being the maximum length of the hull, excluding rudder and bowsprit, "B" being the maximum breadth of the hull in metres, measured to the outer edge of the shell plating (excluding paddle wheels, rubbing strakes, etc.) and "T" being the vertical distance between the lowest moulded point of the hull or the keel and the maximum draught line.

2.8b: *valid navigation or safety certificate* shall mean:

- (a) a certificate proving conformity with the 1974 International Convention for the Safety of Life at Sea (SOLAS), as amended, or equivalent, or
- (b) a certificate proving conformity with the 1966 International Convention on Load Lines, as amended, or equivalent, and an IOPP certificate proving conformity with the 1973 International Convention for the Prevention of Pollution from Ships (MARPOL), as amended.

2.8c: *Defeat device* shall mean a device which measures, senses or responds to operating variables for the purpose of activating, modulating, delaying or deactivating the operation of any component or function of the emission control system such that the effectiveness of the control system is reduced under conditions encountered during the normal non-road mobile machinery use unless the use of such a device is substantially included in the applied emission test certification procedure.

2.8d: *Irrational control strategy* shall mean any strategy or measure that, when the non-road mobile machinery is operated under normal conditions of use, reduces the effectiveness of the emission control system to a level below that expected in the applicable emission test procedures.

(b) The following section shall be inserted:

2.17 *test cycle* shall mean a sequence of test points, each with a defined speed and torque, to be followed by the engine under steady state (NRSC test) or transient operating conditions (NRTC test);

(c) Current Section 2.17 shall be renumbered 2.18 and be replaced by the following:

2.18. Symbols and abbreviations

2.18.1. Symbols for test parameters

Symbol	Unit	Term
A/F _{st}		Stoichiometric air/fuel ratio
A _p	m ²	Cross sectional area of the isokinetic sampling probe

Status: EU Directives are being published on this site to aid cross referencing from UK legislation. After IP completion day (31 December 2020 11pm) no further amendments will be applied to this version.

A_T	m^2	Cross sectional area of the exhaust pipe
Aver		Weighted average values for:
	m^3/h	- volume flow
	kg/h	- mass flow
C1		Carbon 1 equivalent hydrocarbon
C_d		Discharge coefficient of the SSV
Conc	ppm Vol%	Concentration (with suffix of the component nominating)
$Conc_c$	ppm Vol%	Background corrected concentration
$Conc_d$	ppm Vol%	Concentration of the pollutant measured in the dilution air
$Conc_e$	ppm Vol%	Concentration of the pollutant measured in the diluted exhaust gas
d	m	Diameter
DF		Dilution factor
f_a		Laboratory atmospheric factor
G_{AIRD}	kg/h	Intake air mass flow rate on dry basis
G_{AIRW}	kg/h	Intake air mass flow rate on wet basis
G_{DILW}	kg/h	Dilution air mass flow rate on wet basis
G_{EDFW}	kg/h	Equivalent diluted exhaust gas mass flow rate on wet basis
G_{EXHW}	kg/h	Exhaust gas mass flow rate on wet basis
G_{FUEL}	kg/h	Fuel mass flow rate
G_{SE}	kg/h	Sampled exhaust mass flow rate
G_T	cm^3/min	Tracer gas flow rate

Status: EU Directives are being published on this site to aid cross referencing from UK legislation. After IP completion day (31 December 2020 11pm) no further amendments will be applied to this version.

G_{TOTW}	kg/h	Diluted exhaust gas mass flow rate on wet basis
H_a	g/kg	Absolute humidity of the intake air
H_d	g/kg	Absolute humidity of the dilution air
H_{REF}	g/kg	Reference value of absolute humidity (10,71 g/kg)
i		Subscript denoting an individual mode (for NRSC test) or an instantaneous value (for NRTC test)
K_H		Humidity correction factor for NO_x
K_p		Humidity correction factor for particulate
K_V		CFV calibration function
$K_{W,a}$		Dry to wet correction factor for the intake air
$K_{W,d}$		Dry to wet correction factor for the dilution air
$K_{W,e}$		Dry to wet correction factor for the diluted exhaust gas
$K_{W,r}$		Dry to wet correction factor for the raw exhaust gas
L	%	Percent torque related to the maximum torque for the test speed
M_d	mg	Particulate sample mass of the dilution air collected
M_{DIL}	kg	Mass of the dilution air sample passed through the particulate sampling filters

Status: EU Directives are being published on this site to aid cross referencing from UK legislation. After IP completion day (31 December 2020 11pm) no further amendments will be applied to this version.

M_{EDFW}	kg	Mass of equivalent diluted exhaust gas over the cycle
M_{EXHW}	kg	Total exhaust mass flow over the cycle
M_f	mg	Particulate sample mass collected
$M_{f,p}$	mg	Particulate sample mass collected on primary filter
$M_{f,b}$	mg	Particulate sample mass collected on back-up filter
M_{gas}	g	Total mass of gaseous pollutant over the cycle
M_{PT}	g	Total mass of particulate over the cycle
M_{SAM}	kg	Mass of the diluted exhaust sample passed through the particulate sampling filters
M_{SE}	kg	Sampled exhaust mass over the cycle
M_{SEC}	kg	Mass of secondary dilution air
M_{TOT}	kg	Total mass of double diluted exhaust over the cycle
M_{TOTW}	kg	Total mass of diluted exhaust gas passing the dilution tunnel over the cycle on wet basis
$M_{TOTW,I}$	kg	Instantaneous mass of diluted exhaust gas passing the dilution tunnel on wet basis
mass	g/h	Subscript denoting emissions mass flow (rate)
N_p		Total revolutions of PDP over the cycle
n_{ref}	min^{-1}	Reference engine speed for NRTC test

Status: EU Directives are being published on this site to aid cross referencing from UK legislation. After IP completion day (31 December 2020 11pm) no further amendments will be applied to this version.

\dot{n}_{sp}	s ⁻²	Derivative of the engine speed
P	kW	Power, brake uncorrected
p ₁	kPa	Pressure drop below atmospheric at the pump inlet of PDP
P _A	kPa	Absolute pressure
P _a	kPa	Saturation vapour pressure of the engine intake air (ISO 3046: p _{sy} =PSY test ambient)
P _{AE}	kW	Declared total power absorbed by auxiliaries fitted for the test which are not required by paragraph 2.4 of this Annex
P _B	kPa	Total atmospheric pressure (ISO 3046: P _x =PX Site ambient total pressure P _y =PY Test ambient total pressure)
P _d	kPa	Saturation vapour pressure of the dilution air
P _M	kW	Maximum power at the test speed under test conditions (see Annex VII, Appendix 1)
P _m	kW	Power measured on test bed
p _s	kPa	Dry atmospheric pressure
q		Dilution ratio
Q _s	m ³ /s	CVS volume flow rate
r		Ratio of the SSV throat to inlet absolute, static pressure
r		Ratio of cross sectional areas of isokinetic probe and exhaust pipe

Status: EU Directives are being published on this site to aid cross referencing from UK legislation. After IP completion day (31 December 2020 11pm) no further amendments will be applied to this version.

R_a	%	Relative humidity of the intake air
R_d	%	Relative humidity of the dilution air
Re		Reynolds number
R_f		FID response factor
T	K	Absolute temperature
t	s	Measuring time
T_a	K	Absolute temperature of the intake air
T_D	K	Absolute dew point temperature
T_{ref}	K	Reference temperature of combustion air: (298 K)
T_{sp}	N·m	Demanded torque of the transient cycle
t_{10}	s	Time between step input and 10% of final reading
t_{50}	s	Time between step input and 50% of final reading
t_{90}	s	Time between step input and 90% of final reading
Δt_i	s	Time interval for instantaneous CFV flow
V_0	m ³ /rev	PDP volume flow rate at actual conditions
W_{act}	kWh	Actual cycle work of NRTC
WF		Weighting factor
WF_E		Effective weighting factor
X_o	m ³ /rev	Calibration function of PDP volume flow rate
Θ_D	kg·m ²	Rotational inertia of the eddy-current dynamometer

Status: EU Directives are being published on this site to aid cross referencing from UK legislation. After IP completion day (31 December 2020 11pm) no further amendments will be applied to this version.

β		Ratio of the SSV throat diameter, d , to the inlet pipe inner diameter
λ		Relative air/fuel ratio, actual A/F divided by stoichiometric A/F
ρ_{EXH}	kg/m^3	Density of the exhaust gas

2.18.2. Symbols for chemical components

CH ₄	Methane
C ₃ H ₈	Propane
C ₂ H ₆	Ethane
CO	Carbon monoxide
CO ₂	Carbon dioxide
DOP	Di-octylphthalate
H ₂ O	Water
HC	Hydrocarbons
NO _x	Oxides of nitrogen
NO	Nitric oxide
NO ₂	Nitrogen dioxide
O ₂	Oxygen
PT	Particulates
PTFE	Polytetrafluoroethylene

2.18.3. Abbreviations

CFV	Critical Flow Venturi
CLD	Chemiluminescent detector
CI	Compression Ignition
FID	Flame Ionisation Detector
FS	Full scale
HCLD	Heated Chemiluminescent Detector
HFID	Heated Flame Ionisation Detector
NDIR	Non-Dispersive Infrared Analyser
NG	Natural Gas
NRSC	Non-Road Steady Cycle
NRTC	Non-Road Transient Cycle
PDP	Positive Displacement Pump
SI	Spark Ignition
SSV	Sub-Sonic Venturi

3) Section 3 shall be amended as follows:

(a) The following section shall be inserted:

3.1.4. labels in accordance with Annex XIII, if the engine is placed on the market under flexible scheme provisions.

4) Section 4 is amended as follows:

(a) At the end of section 4.1.1. the following shall be added:

Status: EU Directives are being published on this site to aid cross referencing from UK legislation. After IP completion day (31 December 2020 11pm) no further amendments will be applied to this version.

All engines that expel exhaust gases mixed with water shall be equipped with a connection in the engine exhaust system that is located downstream of the engine and before any point at which the exhaust contacts water (or any other cooling/scrubbing medium) for the temporary attachment of gaseous or particulate emissions sampling equipment. It is important that the location of this connection allows a well mixed representative sample of the exhaust. This connection shall be internally threaded with standard pipe threads of a size not larger than one-half inch, and shall be closed by a plug when not in use (equivalent connections are allowed).

(b) The following section shall be added:

4.1.2.4. The emissions of carbon monoxide, the emissions of the sum of hydrocarbons and oxides of nitrogen and the emissions of particulates shall for stage III A not exceed the amounts shown in the table below:

Engines for use in other applications than propulsion of inland waterway vessels, locomotives and railcars:

Category: Net power(P)(kW)	Carbon monoxide(CO) (g/kWh)	Sum of hydrocarbons and oxides of nitrogen(HC +NOx)(g/kWh)	Particulates(PT) (g/kWh)
H: 130 kW ≤ P ≤ 560 kW	3,5	4,0	0,2
I: 75 kW ≤ P < 130 kW	5,0	4,0	0,3
J: 37 kW ≤ P < 75 kW	5,0	4,7	0,4
K: 19 kW ≤ P < 37 kW	5,5	7,5	0,6

ENGINES FOR PROPULSION OF INLAND WATERWAY VESSELS

Category: swept volume/net power(SV/P)(litres per cylinder/kW)	Carbon monoxide(CO) (g/kWh)	Sum of hydrocarbons and oxides of nitrogen(HC +NOx)(g/kWh)	Particulates(PT) (g/kWh)
V1:1 SV < 0,9 and P ≥ 37 kW	5.0	7.5	0.40
V1:2 0,9 ≤ SV < 1,2	5.0	7.2	0.30
V1:3 1,2 ≤ SV < 2,5	5.0	7.2	0.20

Status: EU Directives are being published on this site to aid cross referencing from UK legislation. After IP completion day (31 December 2020 11pm) no further amendments will be applied to this version.

V1:4 2,5≤SV< 5	5.0	7.2	0.20
V2:1 5≤SV<15	5.0	7.8	0.27
V2:2 15≤SV< 20 and P < 3300 kW	5.0	8.7	0.50
V2:3 15≤SV< 20 and P ≥ 3300 kW	5.0	9.8	0.50
V2:4 20≤SV< 25	5,0	9.8	0.50
V2:5 25≤SV< 30	5,0	11.0	0.50

ENGINES FOR PROPULSION OF LOCOMOTIVES

Category: Net power(P) (kW)	Carbon monoxide(CO) (g/kWh)	Sum of hydrocarbons and oxides of nitrogen(HC+NOx)(g/ kWh)		Particulates(PT) (g/kWh)
RL A: 130 kW ≤ P ≤ 560 kW	3,5	4,0		0,2
	Carbon monoxide (CO) (g/kWh)	Hydrocarbons (HC) (g/kWh)	Oxides of nitrogen (NOx) (g/kWh)	Particulates (PT) (g/kWh)
RH A: P > 560 kW	3,5	0,5	6,0	0,2
RH A Engines with P > 2000 kW and SV > 5 l/ cylinder	3,5	0,4	7,4	0,2

ENGINES FOR PROPULSION OF RAILCARS

Category: net power (P) (kW)	Carbon monoxide(CO) (g/kWh)	Sum of hydrocarbons and oxides of nitrogen(HC +NOx)(g/ kWh)	Particulates(PT) (g/kWh)
RC A: 130 kW < P	3,5	4,0	0,20

(c) The following section shall be inserted:

Status: EU Directives are being published on this site to aid cross referencing from UK legislation. After IP completion day (31 December 2020 11pm) no further amendments will be applied to this version.

"4.1.2.5. The emissions of carbon monoxide, the emissions of hydrocarbons and oxides of nitrogen (or their sum where relevant) and the emissions of particulates shall, for stage III B, not exceed the amounts shown in the table below:

ENGINES FOR USE IN OTHER APPLICATIONS
THAN PROPULSION OF LOCOMOTIVES,
RAILCARS AND INLAND WATERWAY VESSELS

Category: net power(P) (kW)	Carbon monoxide(CO) (g/kWh)	Hydrocarbons (HC) (g/kWh)	Oxides of nitrogen(Nox) (g/kWh)	Particulates(PT) (g/kWh)
L: 130 kW ≤ P ≤ 560 kW	3,5	0,19	2,0	0,025
M: 75 kW ≤ P < 130 kW	5,0	0,19	3,3	0,025
N: 56 kW ≤ P < 75 kW	5,0	0,19	3,3	0,025
		Sum of hydrocarbons and oxides of nitrogen (HC+NOx) (g/kWh)		
P: 37 kW ≤ P < 56 kW	5,0	4,7		0,025

ENGINES FOR PROPULSION OF RAILCARS

Category: net power(P) (kW)	Carbon monoxide(CO) (g/kWh)	Hydrocarbons (HC) (g/kWh)	Oxides of nitrogen(Nox) (g/kWh)	Particulates(PT) (g/kWh)
RC B: 130 kW < P	3,5	0.19	2,0	0,025

ENGINES FOR PROPULSION OF LOCOMOTIVES:

Category: Net power(P)(kW)	Carbon monoxide(CO) (g/kWh)	Sum of hydrocarbons and oxides of nitrogen(HC +NOx)(g/ kWh)	Particulates(PT) (g/kWh)
R B: 130 kW < P	3,5	4,0	0,025

(d) The following section shall be inserted after the new section 4.1.2.5:

4.1.2.6. The emissions of carbon monoxide, the emissions of hydrocarbons and oxides of nitrogen (or their sum where relevant) and the

Status: EU Directives are being published on this site to aid cross referencing from UK legislation. After IP completion day (31 December 2020 11pm) no further amendments will be applied to this version.

emissions of particulates shall for stage IV not exceed the amounts shown in the table below:

ENGINES FOR USE IN OTHER APPLICATIONS
THAN PROPULSION OF LOCOMOTIVES,
RAILCARS AND INLAND WATERWAY VESSELS

Category: Net power(P) (kW)	Carbon monoxide(CO) (g/kWh)	Hydrocarbons(HC) (g/kWh)	Oxides of nitrogen(NOx) (g/kWh)	Particulates(PT)
Q: 130 kW ≤ P ≤ 560 kW	3,5	0,19	0,4	0,025
R: 56 kW ≤ P < 130 kW	5,0	0,19	0,4	0,025

(e) The following section shall be inserted:

4.1.2.7. The limit values in sections 4.1.2.4, 4.1.2.5 and 4.1.2.6 shall include deterioration calculated in accordance with Annex III, appendix 5.

In the case of limit values standards contained in sections 4.1.2.5 and 4.1.2.6, under all randomly selected load conditions, belonging to a definite control area and with the exception of specified engine operating conditions which are not subject to such a provision, the emissions sampled during a time duration as small as 30 s shall not exceed by more than 100% the limit values of the above tables. The control area to which the percentage not to be exceeded shall apply and the excluded engine operating conditions shall be defined in accordance with the procedure referred to in Article 15.

(f) Section 4.1.2.4 shall be renumbered to 4.1.2.8

2. ANNEX III SHALL BE AMENDED AS FOLLOWS:

1) Section 1 shall be amended as follows:

(a) The following shall be added to section 1.1.:

Two test cycles are described that shall be applied according to the provisions of Annex I, Section 1:

- the NRSC (Non-Road Steady Cycle) which shall be used for stages I, II and IIIA and for constant speed engines as well as for stages IIIB and IV in the case of gaseous pollutants,
- the NRTC (Non-Road Transient Cycle) which shall be used for the measurement of particulate emissions for stages IIIB and IV and for all engines but constant speed engines. By the choice of the manufacturer this test can be used also for stage IIIA and for the gaseous pollutants in stages IIIB and IV.
- For engines intended to be used in inland waterway vessels the ISO test procedure as specified by ISO 8178-4:2002 [E] and IMO MARPOL 73/78, Annex VI (NO_x Code) shall be used.

Status: EU Directives are being published on this site to aid cross referencing from UK legislation. After IP completion day (31 December 2020 11pm) no further amendments will be applied to this version.

- For engines intended for propulsion of railcars an NRSC shall be used for the measurement of gaseous and particulate pollutants for stage III A and for stage III B.
- For engines intended for propulsion of locomotives an NRSC shall be used for the measurement of gaseous and particulate pollutants for stage III A and for stage III B.

(b) The following section shall be added:

1.3. Measurement principle:

The engine exhaust emissions to be measured include the gaseous components (carbon monoxide, total hydrocarbons and oxides of nitrogen), and the particulates. Additionally, carbon dioxide is often used as a tracer gas for determining the dilution ratio of partial and full flow dilution systems. Good engineering practice recommends the general measurement of carbon dioxide as an excellent tool for the detection of measurement problems during the test run.

1.3.1. NRSC Test:

During a prescribed sequence of operating conditions, with the engines warmed up, the amounts of the above exhaust emissions shall be examined continuously by taking a sample from the raw exhaust gas. The test cycle consists of a number of speed and torque (load) modes, which cover the typical operating range of diesel engines. During each mode, the concentration of each gaseous pollutant, exhaust flow and power output shall be determined, and the measured values weighted. The particulate sample shall be diluted with conditioned ambient air. One sample over the complete test procedure shall be taken and collected on suitable filters.

Alternatively, a sample shall be taken on separate filters, one for each mode, and cycle-weighted results computed.

The grams of each pollutant emitted per kilowatt -hour shall be calculated as described in Appendix 3 to this Annex.

1.3.2. NRTC Test:

The prescribed transient test cycle, based closely on the operating conditions of diesel engines installed in non-road machinery, is run twice:

- The first time (cold start) after the engine has soaked to room temperature and the engine coolant and oil temperatures, after treatment systems and all auxiliary engine control devices are stabilised between 20 and 30°C.
- The second time (hot start) after a twenty-minute hot soak that commences immediately after the completion of the cold start cycle.

During this test sequence the above pollutants shall be examined. Using the engine torque and speed feedback signals of the engine dynamometer, the power shall be integrated with respect to the time of the cycle, resulting in the work produced by the engine over the cycle. The concentrations of the gaseous components shall be determined over the cycle, either in the raw exhaust gas by integration of the analyzer signal in accordance with

Appendix 3 to this Annex, or in the diluted exhaust gas of a CVS full-flow dilution system by integration or by bag sampling in accordance with Appendix 3 to this Annex. For particulates, a proportional sample shall be collected from the diluted exhaust gas on a specified filter by either partial flow dilution or full-flow dilution. Depending on the method used, the diluted or undiluted exhaust gas flow rate shall be determined over the cycle to calculate the mass emission values of the pollutants. The mass emission values shall be related to the engine work to give the grams of each pollutant emitted per kilowatt-hour.

Emissions (g/kWh) shall be measured during both the cold and hot start cycles. Composite weighted emissions shall be computed by weighting the cold start results 10% and the hot start results 90%. Weighted composite results shall meet the standards.

Prior to the introduction of the cold/hot composite test sequence, the symbols (Annex I, section 2.18) the test sequence (Annex III) and calculation equations (Annex III, Appendix III) shall be modified in accordance with the procedure referred to in Article 15.

2) Section 2 shall be amended as follows:

(a) Section 2.2.3 shall be replaced by the following:

2.2.3. Engines with charge air cooling

The charge air temperature shall be recorded and, at the declared rated speed and full load, shall be within ± 5 K of the maximum charge air temperature specified by the manufacturer. The temperature of the cooling medium shall be at least 293 K (20°C).

If a test shop system or external blower is used, the charge air temperature shall be set to within ± 5 K of the maximum charge air temperature specified by the manufacturer at the speed of the declared maximum power and full load. Coolant temperature and coolant flow rate of the charge air cooler at the above set point shall not be changed for the whole test cycle. The charge air cooler volume shall be based upon good engineering practice and typical vehicle/machinery applications.

Optionally, the setting of the charge air cooler may be done in accordance with SAE J 1937 as published in January 1995.

(b) The text under section 2.3 shall be replaced by the following:

The test engine shall be equipped with an air inlet system presenting an air inlet restriction within ± 300 Pa of the value specified by the manufacturer for a clean air cleaner at the engine operating conditions as specified by the manufacturer, which result in maximum air flow. The restrictions are to be set at rated speed and full load. A test shop system may be used, provided it duplicates actual engine operating conditions.

(c) The text under section 2.4 Engine exhaust system shall be replaced by the following:

The test engine shall be equipped with an exhaust system with exhaust back pressure within ± 650 Pa of the value specified by the manufacturer at the engine operating conditions resulting in maximum declared power.

Status: EU Directives are being published on this site to aid cross referencing from UK legislation. After IP completion day (31 December 2020 11pm) no further amendments will be applied to this version.

If the engine is equipped with an exhaust after-treatment device, the exhaust pipe shall have the same diameter as found in-use for at least 4 pipe diameters upstream to the inlet of the beginning of the expansion section containing the after-treatment device. The distance from the exhaust manifold flange or turbocharger outlet to the exhaust after-treatment device shall be the same as in the machine configuration or within the distance specifications of the manufacturer. The exhaust backpressure or restriction shall follow the same criteria as above, and may be set with a valve. The aftertreatment container may be removed during dummy tests and during engine mapping, and replaced with an equivalent container having an inactive catalyst support.

(d) Section 2.8 shall be deleted.

3) Section 3 shall be amended as follows:

(a) The title of section 3 shall be replaced by:

3.TEST RUN (NRSC TEST)

(b) The following section shall be inserted:

3.1. Determination of dynamometer settings

The basis of specific emissions measurement is uncorrected brake power according to ISO 14396: 2002.

Certain auxiliaries, which are necessary only for the operation of the machine and may be mounted on the engine, should be removed for the test. The following incomplete list is given as an example:

- air compressor for brakes
- power steering compressor
- air conditioning compressor
- pumps for hydraulic actuators.

Where auxiliaries have not been removed, the power absorbed by them at the test speeds shall be determined in order to calculate the dynamometer settings, except for engines where such auxiliaries form an integral part of the engine (e.g. cooling fans for air cool engines).

The settings of inlet restriction and exhaust pipe backpressure shall be adjusted to the manufacturer's upper limits, in accordance with sections 2.3 and 2.4.

The maximum torque values at the specified test speeds shall be determined by experimentation in order to calculate the torque values for the specified test modes. For engines which are not designed to operate over a range on a full load torque curve, the maximum torque at the test speeds shall be declared by the manufacturer.

The engine setting for each test mode shall be calculated using the formula:

$$S = \left((P_M + P_{AE}) \times \frac{L}{100} \right) - P_{AE}$$

If the ratio,

$$\frac{P_{AE}}{P_M} \geq 0,03$$

the value of P_{AE} may be verified by the technical authority granting type approval.

- (c) Current sections 3.1 - 3.3 shall be renumbered 3.2 - 3.4
- (d) Current section 3.4 shall be renumbered 3.5 and replaced by the following:

3.5. Adjustment of the dilution ratio

The particulate sampling system shall be started and running on bypass for the single filter method (optional for the multiple filter method). The particulate background level of the dilution air may be determined by passing dilution air through the particulate filters. If filtered dilution air is used, one measurement may be done at any time prior to, during, or after the test. If the dilution air is not filtered, the measurement must be done on one sample taken for the duration of the test.

The dilution air shall be set to obtain a filter face temperature between 315 K (42°C) and 325 K (52°C) at each mode. The total dilution ratio shall not be less than four.

NOTE: For steady-state procedure, the filter temperature may be kept at or below the maximum temperature of 325 K (52°C) instead of respecting the temperature range of 42°C - 52°C.

For the single and multiple filter methods, the sample mass flow rate through the filter shall be maintained at a constant proportion of the dilute exhaust mass flow rate for full flow systems for all modes. This mass ratio shall be within $\pm 5\%$ with respect to the averaged value of the mode, except for the first 10 seconds of each mode for systems without bypass capability. For partial flow dilution systems with single filter method, the mass flow rate through the filter shall be constant within $\pm 5\%$ with respect to the averaged value of the mode, except for the first 10 seconds of each mode for systems without bypass capability.

For CO₂ or NO_x concentration controlled systems, the CO₂ or NO_x content of the dilution air must be measured at the beginning and at the end of each test. The pre and post test background CO₂ or NO_x concentration measurements of the dilution air must be within 100 ppm or 5 ppm of each other, respectively.

When using a dilute exhaust gas analysis system, the relevant background concentrations shall be determined by sampling dilution air into a sampling bag over the complete test sequence.

Continuous (non-bag) background concentration may be taken at the minimum of three points, at the beginning, at the end, and a point near the middle of the cycle and averaged. At the manufacturer's request background measurements may be omitted.

- (e) Current sections 3.5-3.6 shall be renumbered 3.6-3.7.
- (f) Current sections 3.6.1 shall be replaced by the following:
 - 3.7.1. Equipment specification according to Section 1A of Annex I:

Status: EU Directives are being published on this site to aid cross referencing from UK legislation. After IP completion day (31 December 2020 11pm) no further amendments will be applied to this version.

3.7.1.1. Specification A.

For engines covered by Section 1A(i) and A(iv) of Annex I, the following 8-mode cycle⁽¹⁰⁾ shall be followed in dynamometer operation on the test engine:

Mode Number	Engine Speed	Load	Weighting Factor
1	Rated	100	0,15
2	Rated	75	0,15
3	Rated	50	0,15
4	Rated	10	0,10
5	Intermediate	100	0,10
6	Intermediate	75	0,10
7	Intermediate	50	0,10
8	Idle	---	0,15

3.7.1.2. Specification B.

For engines covered by Section 1A(ii) of Annex I, the following 5-mode cycle⁽¹¹⁾ shall be followed in dynamometer operation on the test engine:

Mode Number	Engine Speed	Load	Weighting Factor
1	Rated	100	0,05
2	Rated	75	0,25
3	Rated	50	0,30
4	Rated	25	0,30
5	Rated	10	0,10

The load figures are percentage values of the torque corresponding to the prime power rating defined as the maximum power available during a variable power sequence, which may be run for an unlimited number of hours per year, between stated maintenance intervals and under the stated ambient conditions, the maintenance being carried out as prescribed by the manufacturer.

3.7.1.3. Specification C.

For propulsion engines⁽¹²⁾ intended to be used in inland waterway vessels the ISO test procedure as specified by ISO 81784:2002(E) and IMO MARPOL 73/78, Annex VI (NO_x Code) shall be used.

Propulsion engines that operate on a fixed-pitch propeller curve shall be tested on a dynamometer using the following 4-mode

Status: EU Directives are being published on this site to aid cross referencing from UK legislation. After IP completion day (31 December 2020 11pm) no further amendments will be applied to this version.

steady-state cycle⁽¹³⁾ developed to represent in-use operation of commercial marine diesel engines:

Mode Number	Engine Speed	Load	Weighting Factor
1	100% (Rated)	100	0,20
2	91%	75	0,50
3	80%	50	0,15
4	63%	25	0,15

Fixed speed inland waterway propulsion engines with variable pitch or electrically coupled propellers shall be tested on a dynamometer using the following 4-mode steady-state cycle⁽¹⁴⁾ characterised by the same load and weighting factors as the above cycle, but with engine operated in each mode at rated speed:

Mode Number	Engine Speed	Load	Weighting Factor
1	Rated	100	0,20
2	Rated	75	0,50
3	Rated	50	0,15
4	Rated	25	0,15

3.7.1.4. Specification D

For engines covered by Section 1A(v) of Annex I, the following 3-mode cycle⁽¹⁵⁾ shall be followed in dynamometer operation on the test engine:

Mode Number	Engine Speed	Load	Weighting Factor
1	Rated	100	0,25
2	Intermediate	50	0,15
3	Idle		0,60

- (g) Current section 3.7.3. shall be replaced by the following:

The test sequence shall be started. The test shall be performed in the order of the mode numbers as set out above for the test cycles.

During each mode of the given test cycle after the initial transition period, the specified speed shall be held to within $\pm 1\%$ of rated speed or ± 3 min⁻¹, whichever is greater, except for low idle which shall be within the tolerances declared by the manufacturer. The specified torque shall be held so that the average over the period during which the measurements are being taken is within $\pm 2\%$ of the maximum torque at the test speed.

Status: EU Directives are being published on this site to aid cross referencing from UK legislation. After IP completion day (31 December 2020 11pm) no further amendments will be applied to this version.

For each measuring point a minimum time of 10 minutes is necessary. If for the testing of an engine, longer sampling times are required for reasons of obtaining sufficient particulate mass on the measuring filter the test mode period can be extended as necessary.

The mode length shall be recorded and reported.

The gaseous exhaust emission concentration values shall be measured and recorded during the last three minutes of the mode.

The particulate sampling and the gaseous emission measurement should not commence before engine stabilisation, as defined by the manufacturer, has been achieved and their completion must be coincident.

The fuel temperature shall be measured at the inlet to the fuel injection pump or as specified by the manufacturer, and the location of measurement recorded.

(h) The current section 3.7 shall be renumbered 3.8.

4) The following section shall be inserted:

4. TEST RUN (NRTC TEST)

4.1. Introduction

The non-road transient cycle (NRTC) is listed in Annex III, Appendix 4 as a second-by-second sequence of normalized speed and torque values applicable to all diesel engines covered by this Directive. In order to perform the test on an engine test cell, the normalised values shall be converted to the actual values for the individual engine under test, based on the engine mapping curve. This conversion is referred to as denormalisation, and the test cycle developed is referred to as the reference cycle of the engine to be tested. With these reference speed and torque values, the cycle shall be run on the test cell, and the feedback speed and torque values recorded. In order to validate the test run, a regression analysis between reference and feedback speed and torque values shall be conducted upon completion of the test.

4.1.1. The use of defeat devices or irrational control or irrational emission control strategies shall be prohibited

4.2. Engine mapping procedure

When generating the NRTC on the test cell, the engine shall be mapped before running the test cycle to determine the speed vs torque curve.

4.2.1. Determination of the mapping speed range

The minimum and maximum mapping speeds are defined as follows:

Minimum mapping speed	=	idle speed
Maximum mapping speed	=	$n_{hi} \times 1,02$ or speed where full load torque drops off to zero, whichever is lower

(where n_{hi} is the high speed, defined as the highest engine speed where 70% of the rated power is delivered).

4.2.2. Engine mapping curve

The engine shall be warmed up at maximum power in order to stabilise the engine parameters according to the recommendation of the manufacturer and good engineering practice. When the engine is stabilised, the engine mapping shall be performed according to the following procedures.

4.2.2.1. Transient map

- (a) The engine shall be unloaded and operated at idle speed.
- (b) The engine shall be operated at full load setting of the injection pump at minimum mapping speed.
- (c) The engine speed shall be increased at an average rate of $8 \pm 1 \text{ min}^{-1} / \text{s}$ from minimum to maximum mapping speed. Engine speed and torque points shall be recorded at a sample rate of at least one point per second.

4.2.2.2. Step map

- (a) The engine shall be unloaded and operated at idle speed.
- (b) The engine shall be operated at full load setting of the injection pump at minimum mapping speed.
- (c) While maintaining full load, the minimum mapping speed shall be maintained for at least 15 s, and the average torque during the last 5 s shall be recorded. The maximum torque curve from minimum to maximum mapping speed shall be determined in no greater than $100 \pm 20 / \text{min}$ speed increments. Each test point shall be held for at least 15 s, and the average torque during the last 5 s shall be recorded.

4.2.3. Mapping curve generation

All data points recorded under section 4.2.2 shall be connected using linear interpolation between points. The resulting torque curve is the mapping curve and shall be used to convert the normalized torque values of the engine dynamometer schedule of Annex IV into actual torque values for the test cycle, as described in section 4.3.3.

4.2.4. Alternate mapping

If a manufacturer believes that the above mapping techniques are unsafe or unrepresentative for any given engine, alternate mapping techniques may be used. These alternate techniques must satisfy the intent of the specified mapping procedures to determine the maximum available torque at all engine speeds achieved during the test cycles. Deviations from the mapping techniques specified in this section for reasons of safety or representativeness shall be approved by the parties involved along with the justification for their use. In no case, however, shall the torque curve be run by descending engine speeds for governed or turbocharged engines.

4.2.5. Replicate tests

An engine need not be mapped before each and every test cycle. An engine must be remapped prior to a test cycle if:

- an unreasonable amount of time has transpired since the last map, as determined by engineering judgement,

Status: EU Directives are being published on this site to aid cross referencing from UK legislation. After IP completion day (31 December 2020 11pm) no further amendments will be applied to this version.

or,

- physical changes or recalibrations have been made to the engine, which may potentially affect engine performance.

4.3. Generation of the reference test cycle

4.3.1. Reference speed

The reference speed (n_{ref}) corresponds to the 100% normalized speed values specified in the engine dynamometer schedule of Annex III, Appendix 4. It is obvious that the actual engine cycle resulting from denormalization to the reference speed largely depends on selection of the proper reference speed. The reference speed shall be determined by the following definition:

$$n_{ref} = \text{low speed} + 0,95 \times (\text{high speed} - \text{low speed})$$

(the high speed is the highest engine speed where 70% of the rated power is delivered, while the low speed is the lowest engine speed where 50% of the rated power is delivered).

4.3.2. Denormalization of engine speed

The speed shall be denormalized using the following equation:

$$\text{Actual speed} = \frac{\% \text{speed} \times (\text{reference speed} - \text{idle speed})}{100} + \text{idle speed}$$

4.3.3. Denormalization of engine torque

The torque values in the engine dynamometer schedule of Annex III, Appendix 4 are normalized to the maximum torque at the respective speed. The torque values of the reference cycle shall be denormalized, using the mapping curve determined according to Section 4.2.2, as follows:

$$\text{Actual torque} = \frac{\% \text{ torque} \times \text{max. torque}}{100} \quad (5)$$

for the respective actual speed as determined in Section 4.3.2.

4.3.4. Example of denormalization procedure

As an example, the following test point shall be denormalized:

$$\% \text{ speed} = 43\%$$

$$\% \text{ torque} = 82\%$$

Given the following values:

$$\text{reference speed} = 2200 \text{ /min}$$

$$\text{idle speed} = 600 \text{ /min}$$

results in

$$\text{actual speed} = \frac{43 \times (2200 - 600)}{100} + 600 = 1288 \text{ /min}$$

With the maximum torque of 700 Nm observed from the mapping curve at 1288 /min

$$\text{actual torque} = \frac{82 \times 700}{100} = 574 \text{ Nm}$$

4.4. Dynamometer

Status: EU Directives are being published on this site to aid cross referencing from UK legislation. After IP completion day (31 December 2020 11pm) no further amendments will be applied to this version.

4.4.1. When using a load cell, the torque signal shall be transferred to the engine axis and the inertia of the dyno shall be considered. The actual engine torque is the torque read on the load cell plus the moment of inertia of the brake multiplied by the angular acceleration. The control system has to perform this calculation in real time.

4.4.2. If the engine is tested with an eddy-current dynamometer, it is recommended that the number of points, where the difference

$$T_{sp} - 2 \cdot \pi \cdot \dot{n}_{sp} \cdot \Theta_D$$

is smaller than - 5% of the peak torque, does not exceed 30 (where T_{sp} is the demanded torque,

$$\dot{n}_{sp}$$

is the derivative of the engine speed and Θ_D is the rotational inertia of the eddy-current dynamometer).

4.5. Emissions test run

The following flow chart outlines the test sequence.

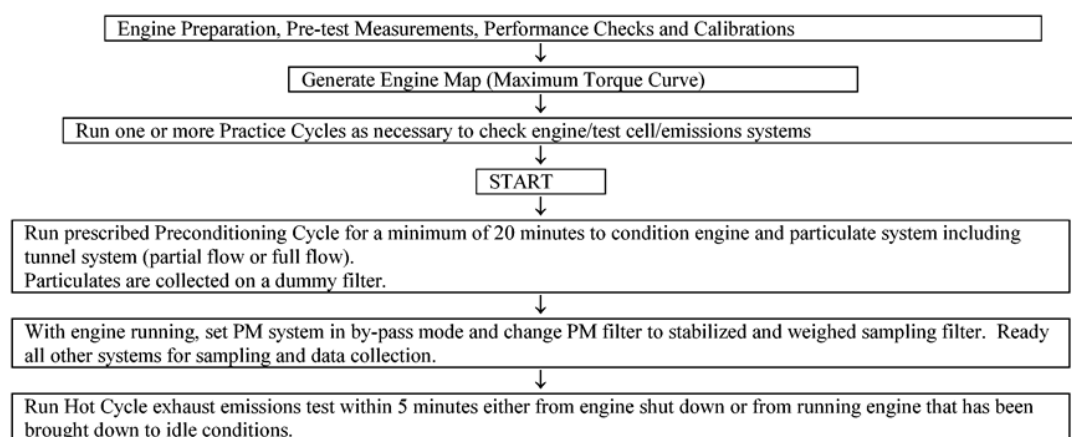

One or more Practice Cycles may be run as necessary to check engine, test cell and emissions systems before the measurement cycle.

4.5.1. Preparation of the sampling filters

At least one hour before the test, each filter shall be placed in a petri dish, which is protected against dust contamination and allows air exchange, and placed in a weighing chamber for stabilization. At the end of the stabilization period, each filter shall be weighed and the weight shall be recorded. The filter shall then be stored in a closed petri dish or sealed filter holder until needed for testing. The filter shall be used within eight hours of its removal from the weighing chamber. The tare weight shall be recorded.

4.5.2. Installation of the measuring equipment

The instrumentation and sample probes shall be installed as required. The tailpipe shall be connected to the full flow dilution system, if used.

4.5.3. Starting and preconditioning the dilution system and the engine

Status: EU Directives are being published on this site to aid cross referencing from UK legislation. After IP completion day (31 December 2020 11pm) no further amendments will be applied to this version.

The dilution system and the engine shall be started and warmed up. The sampling system preconditioning shall be conducted by operating the engine at a condition of rated-speed, 100 percent torque for a minimum of 20 minutes while simultaneously operating either the Partial flow Sampling System or the Full flow CVS with secondary dilution system. Dummy particulate matter emissions samples are then collected. Particulate sample filters need not be stabilized or weighed, and may be discarded. Filter media may be changed during conditioning as long as the total sampled time through the filters and sampling system exceeds 20 minutes. Flow rates shall be set at the approximate flow rates selected for transient testing. Torque shall be reduced from 100 percent torque while maintaining the rated speed condition as necessary so as not to exceed the 191 °C maximum sample zone temperature specifications.

4.5.4. Starting the particulate sampling system

The particulate sampling system shall be started and run on by-pass. The particulate background level of the dilution air may be determined by sampling the dilution air prior to entrance of the exhaust into the dilution tunnel. It is preferred that background particulate sample be collected during the transient cycle if another PM sampling system is available. Otherwise, the PM sampling system used to collect transient cycle PM can be used. If filtered dilution air is used, one measurement may be done prior to or after the test. If the dilution air is not filtered, measurements should be carried out prior to the beginning and after the end of the cycle and the values averaged.

4.5.5. Adjustment of the dilution system

The total diluted exhaust gas flow of a full flow dilution system or the diluted exhaust gas flow through a partial flow dilution system shall be set to eliminate water condensation in the system, and to obtain a filter face temperature between 315 K (42°C) and 325 K (52°C).

4.5.6. Checking the analyzers

The emission analyzers shall be set at zero and spanned. If sample bags are used, they shall be evacuated.

4.5.7. Engine starting procedure

The stabilized engine shall be started within 5 min after completion of warm-up according to the starting procedure recommended by the manufacturer in the owner's manual, using either a production starter motor or the dynamometer. Optionally, the test may start within 5 min of the engine preconditioning phase without shutting the engine off, when the engine has been brought to an idle condition.

4.5.8. Cycle run

4.5.8.1. Test sequence

The test sequence shall commence when the engine is started from shut down after the preconditioning phase or from idle conditions when starting directly from the preconditioning phase with the engine running. The test shall be performed according to the reference cycle as set out in Annex III, Appendix 4. Engine speed and torque command set points shall be issued at 5 Hz (10 Hz recommended) or greater. The set points shall be calculated by linear interpolation between the 1 Hz set points of the reference cycle. Feedback engine speed and torque shall be recorded at least once every second during the test cycle, and the signals may be electronically filtered.

4.5.8.2. Analyzer response

At the start of the engine or test sequence, if the cycle is started directly from preconditioning, the measuring equipment shall be started, simultaneously:

- start collecting or analyzing dilution air, if a full flow dilution system is used;
- start collecting or analyzing raw or diluted exhaust gas, depending on the method used;
- start measuring the amount of diluted exhaust gas and the required temperatures and pressures;
- start recording the exhaust gas mass flow rate, if raw exhaust gas analysis is used;
- recording the feedback data of speed and torque of the dynamometer.

If raw exhaust measurement is used, the emission concentrations (HC, CO and NO_x) and the exhaust gas mass flow rate shall be measured continuously and stored with at least 2 Hz on a computer system. All other data may be recorded with a sample rate of at least 1 Hz. For analogue analyzers the response shall be recorded, and the calibration data may be applied online or offline during the data evaluation.

If a full flow dilution system is used, HC and NO_x shall be measured continuously in the dilution tunnel with a frequency of at least 2 Hz. The average concentrations shall be determined by integrating the analyzer signals over the test cycle. The system response time shall be no greater than 20 s, and shall be coordinated with CVS flow fluctuations and sampling time/test cycle offsets, if necessary. CO and CO₂ shall be determined by integration or by analyzing the concentrations in the sample bag collected over the cycle. The concentrations of the gaseous pollutants in the dilution air shall be determined by integration or by collection in the background bag. All other parameters that need to be measured shall be recorded with a minimum of one measurement per second (1 Hz).

4.5.8.3. Particulate sampling

At the start of the engine or test sequence, if the cycle is started directly from preconditioning, the particulate sampling system shall be switched from by-pass to collecting particulates.

If a partial flow dilution system is used, the sample pump(s) shall be adjusted so that the flow rate through the particulate sample probe or transfer tube is maintained proportional to the exhaust mass flow rate.

If a full flow dilution system is used, the sample pump(s) shall be adjusted so that the flow rate through the particulate sample probe or transfer tube is maintained at a value within $\pm 5\%$ of the set flow rate. If flow compensation (i.e., proportional control of sample flow) is used, it must be demonstrated that the ratio of main tunnel flow to particulate sample flow does not change by more than $\pm 5\%$ of its set value (except for the first 10 seconds of sampling).

NOTE: For double dilution operation, sample flow is the net difference between the flow rate through the sample filters and the secondary dilution airflow rate.

The average temperature and pressure at the gas meter(s) or flow instrumentation inlet shall be recorded. If the set flow rate cannot be maintained over the complete cycle (within $\pm 5\%$) because of high particulate loading on the filter, the test shall be voided. The test shall be rerun using a lower flow rate and/or a larger diameter filter.

Status: EU Directives are being published on this site to aid cross referencing from UK legislation. After IP completion day (31 December 2020 11pm) no further amendments will be applied to this version.

4.5.8.4. Engine stalling

If the engine stalls anywhere during the test cycle, the engine shall be preconditioned and restarted, and the test repeated. If a malfunction occurs in any of the required test equipment during the test cycle, the test shall be voided.

4.5.8.5. Operations after test

At the completion of the test, the measurement of the exhaust gas mass flow rate, the diluted exhaust gas volume, the gas flow into the collecting bags and the particulate sample pump shall be stopped. For an integrating analyzer system, sampling shall continue until system response times have elapsed.

The concentrations of the collecting bags, if used, shall be analyzed as soon as possible and in any case not later than 20 minutes after the end of the test cycle.

After the emission test, a zero gas and the same span gas shall be used for re-checking the analyzers. The test will be considered acceptable if the difference between the pre-test and post-test results is less than 2% of the span gas value.

The particulate filters shall be returned to the weighing chamber no later than one hour after completion of the test. They shall be conditioned in a petri dish, which is protected against dust contamination and allows air exchange, for at least one hour, and then weighed. The gross weight of the filters shall be recorded.

4.6. Verification of the test run

4.6.1. Data Shift

To minimise the biasing effect of the time lag between the feedback and reference cycle values, the entire engine speed and torque feedback signal sequence may be advanced or delayed in time with respect to the reference speed and torque sequence. If the feedback signals are shifted, both speed and torque must be shifted by the same amount in the same direction.

4.6.2. Calculation of the Cycle Work

The actual cycle work W_{act} (kWh) shall be calculated using each pair of engine feedback speed and torque values recorded. The actual cycle work W_{act} is used for comparison to the reference cycle work W_{ref} and for calculating the brake specific emissions. The same methodology shall be used for integrating both reference and actual engine power. If values are to be determined between adjacent reference or adjacent measured values, linear interpolation shall be used.

In integrating the reference and actual cycle work, all negative torque values shall be set equal to zero and included. If integration is performed at a frequency of less than 5 Hertz, and if, during a given time segment, the torque value changes from positive to negative or negative to positive, the negative portion shall be computed and set equal to zero. The positive portion shall be included in the integrated value.

W_{act} shall be between -15% and + 5% of W_{ref} .

4.6.3. Validation Statistics of the Test Cycle

Linear regressions of the feedback values on the reference values shall be performed for speed, torque and power. This shall be done after any feedback data shift has

Status: EU Directives are being published on this site to aid cross referencing from UK legislation. After IP completion day (31 December 2020 11pm) no further amendments will be applied to this version.

occurred, if this option is selected. The method of least squares shall be used, with the best fit equation having the form:

$$y = mx + b$$

where:

y	=	feedback (actual) value of speed (min^{-1}), torque ($\text{N}\cdot\text{m}$), or power (kW)
m	=	slope of the regression line
x	=	reference value of speed (min^{-1}), torque ($\text{N}\cdot\text{m}$), or power (kW)
b	=	y intercept of the regression line

The standard error of estimate (SE) of y on x and the coefficient of determination (r^2) shall be calculated for each regression line.

It is recommended that this analysis be performed at 1 Hertz. For a test to be considered valid, the criteria of Table 1 must be met.

TABLE 1: REGRESSION LINE TOLERANCES

	Speed	Torque	Power
Standard error of estimate (SE) of Y on X	max 100 min^{-1}	max 13 % of power map maximum engine torque	max 8% of power map maximum engine power
Slope of the regression line, m	0,95 to 1,03	0,83 - 1,03	0,89 - 1,03
Coefficient of determination, r^2	min 0,9700	min 0,8800	min 0,9100
Y intercept of the regression line, b	$\pm 50 \text{ min}^{-1}$	$\pm 20 \text{ N}\cdot\text{m}$ or $\pm 2\%$ of max torque, whichever is greater	$\pm 4 \text{ kW}$ or $\pm 2\%$ of max power, whichever is greater

For regression purposes only, point deletions are permitted where noted in Table 2 before doing the regression calculation. However, those points must not be deleted for the calculation of cycle work and emissions. An idle point is defined as a point having a normalized reference torque of 0% and a normalized reference speed of 0%. Point deletion may be applied to the whole or to any part of the cycle.

TABLE 2. PERMITTED POINT DELETIONS FROM REGRESSION ANALYSIS

(points to which the point deletion is applied have to be specified)

CONDITION	SPEED AND/OR TORQUE AND/OR POWER POINTS WHICH MAY BE DELETED WITH REFERENCE TO THE
------------------	---

Status: EU Directives are being published on this site to aid cross referencing from UK legislation. After IP completion day (31 December 2020 11pm) no further amendments will be applied to this version.

	CONDITIONS LISTED IN THE LEFT COLUMN
First 24 (± 1) sand last 25 s	Speed, torque and power
Wide open throttle, and torque feedback < 95% torque reference	Torque and/or power
Wide open throttle, and speed feedback < 95% speed reference	Speed and/or power
Closed throttle, speed feedback > idle speed + 50 min ⁻¹ , and torque feedback > 105% torque reference	Torque and/or power
Closed throttle, speed feedback = idle speed + 50 min ⁻¹ , and torque feedback = Manufacturer defined/measured idle torque $\pm 2\%$ of max torque	Speed and/or power
Closed throttle and speed feedback > 105% speed reference	Speed and/or power

5) Appendix 1 shall be replaced by the following:

"APPENDIX 1

MEASUREMENT AND SAMPLING PROCEDURES

1. MEASUREMENT AND SAMPLING PROCEDURES (NRSC TEST)

Gaseous and particulate components emitted by the engine submitted for testing shall be measured by the methods described in Annex VI. The methods of Annex VI describe the recommended analytical systems for the gaseous emissions (Section 1.1) and the recommended particulate dilution and sampling systems (Section 1.2).

1.1. Dynamometer specification

An engine dynamometer with adequate characteristics to perform the test cycle described in Annex III, Section 3.7.1 shall be used. The instrumentation for torque and speed measurement shall allow the measurement of the power within the given limits. Additional calculations may be necessary. The accuracy of the measuring equipment must be such that the maximum tolerances of the figures given in point 1.3 are not exceeded.

1.2. Exhaust gas flow

The exhaust gas flow shall be determined by one of the methods mentioned in sections 1.2.1 to 1.2.4.

1.2.1. Direct measurement method

Direct measurement of the exhaust flow by flow nozzle or equivalent metering system (for detail see ISO 5167:2000).

NOTE: Direct gaseous flow measurement is a difficult task. Precautions must be taken to avoid measurement errors that will impact emission value errors.

1.2.2. Air and fuel measurement method

Measurement of the airflow and the fuel flow.

Air flow-meters and fuel flow-meters with the accuracy defined in Section 1.3 shall be used.

The calculation of the exhaust gas flow is as follows:

$$G_{\text{EXHW}} = G_{\text{AIRW}} + G_{\text{FUEL}} \text{ (for wet exhaust mass)}$$

1.2.3. Carbon balance method

Exhaust mass calculation from fuel consumption and exhaust gas concentrations using the carbon balance method (Annex III, Appendix 3).

1.2.4. Tracer measurement method

This method involves measurement of the concentration of a tracer gas in the exhaust.

A known amount of an inert gas (e.g. pure helium) shall be injected into the exhaust gas flow as a tracer. The gas is mixed and diluted by the exhaust gas, but must not react in the exhaust pipe. The concentration of the gas shall then be measured in the exhaust gas sample.

In order to ensure complete mixing of the tracer gas, the exhaust gas sampling probe shall be located at least 1 m or 30 times the diameter of the exhaust pipe, whichever is larger, downstream of the tracer gas injection point. The sampling probe may be located closer to the injection point if complete mixing is verified by comparing the tracer gas concentration with the reference concentration when the tracer gas is injected upstream of the engine.

The tracer gas flow rate shall be set so that the tracer gas concentration at engine idle speed after mixing becomes lower than the full scale of the trace gas analyzer.

The calculation of the exhaust gas flow is as follows:

$$G_{\text{EXHW}} = \frac{G_{\text{T}} \times \rho_{\text{EXH}}}{60 \times (\text{conc}_{\text{mix}} - \text{conc}_{\text{a}})}$$

where

G_{EXHW}	=	<i>instantaneous exhaust mass flow (kg/s)</i>
G_{T}	=	<i>tracer gas flow (cm³/min)</i>
conc_{mix}	=	<i>instantaneous concentration of the tracer gas after mixing, (ppm)</i>
ρ_{EXH}	=	<i>density of the exhaust gas (kg/m³)</i>
conc_{a}	=	<i>background concentration of the tracer gas in the intake air (ppm)</i>

The background concentration of the tracer gas (conc_{a}) may be determined by averaging the background concentration measured immediately before and after the test run.

When the background concentration is less than 1% of the concentration of the tracer gas after mixing (conc_{mix}) at maximum exhaust flow, the background concentration may be neglected.

Status: EU Directives are being published on this site to aid cross referencing from UK legislation. After IP completion day (31 December 2020 11pm) no further amendments will be applied to this version.

The total system shall meet the accuracy specifications for the exhaust gas flow and shall be calibrated according to Appendix 2, Section 1.11.2

1.2.5. Air flow and air to fuel ratio measurement method

This method involves exhaust mass calculation from the air flow and the air to fuel ratio. The calculation of the instantaneous exhaust gas mass flow is as follows:

$$G_{EXHW} = G_{AIRW} \times \left(1 + \frac{1}{A/F_{st} \times \lambda}\right)$$

with $A / F_{st} = 14,5$

$$\lambda = \frac{\left(100 - \frac{conc_{CO} \times 10^{-4}}{2} - conc_{HC} \times 10^{-4}\right) + \left(0,45 \cdot \frac{1 - \frac{2 \times conc_{CO} \times 10^{-4}}{3,5 \times conc_{CO_2}}}{1 + \frac{conc_{CO} \times 10^{-4}}{3,5 \times conc_{CO_2}}}\right) \times (conc_{CO_2} + conc_{CO} \times 10^{-4})}{6,9078 \times (conc_{CO_2} + conc_{CO} \times 10^{-4}) + conc_{HC} \times 10^{-4}}$$

where

A/F _{st}	=	stoichiometric air/fuel ratio (kg/kg)
λ	=	relative air /fuel ratio
conc _{CO₂}	=	dry CO ₂ concentration (%)
conc _{CO}	=	dry CO concentration (ppm)
conc _{HC}	=	HC concentration (ppm)

NOTE: The calculation refers to a diesel fuel with a H/C ratio equal to 1.8.

The air flowmeter shall meet the accuracy specifications in Table 3, the CO₂ analyzer used shall meet the specifications of clause 1.4.1, and the total system shall meet the accuracy specifications for the exhaust gas flow.

Optionally, air to fuel ratio measurement equipment, such as a zirconia type sensor, may be used for the measurement of the relative air to fuel ratio in accordance with the specifications of clause 1.4.4.

1.2.6. Total dilute exhaust gas flow

When using a full flow dilution system, the total flow of the dilute exhaust (G_{TOTW}) shall be measured with a PDP or CFV or SSV (Annex VI, Section 1.2.1.2.) The accuracy shall conform to the provisions of Annex III, Appendix 2, Section 2.2.

1.3. Accuracy

The calibration of all measurement instruments shall be traceable to national or international standards and comply with the requirements listed in Table 3.

TABLE 3. ACCURACY OF MEASURING INSTRUMENTS

No.	Measuring Instrument	Accuracy
1	Engine speed	± 2% of reading or ± 1% of engine's max. value whichever is larger
2	Torque	± 2% of reading or ± 1% of engine's max. value whichever is larger

Status: EU Directives are being published on this site to aid cross referencing from UK legislation. After IP completion day (31 December 2020 11pm) no further amendments will be applied to this version.

3	Fuel consumption	± 2% of engine's max. value
4	Air consumption	± 2% of reading or ± 1% of engine's max. value whichever is larger
5	Exhaust gas flow	± 2,5% of reading or ± 1,5% of engine's max. value whichever is larger
6	Temperatures ≤ 600 K	+ 2 K absolute
7	Temperatures > 600 K	± 1% of reading
8	Exhaust gas pressure	± 0,2 kPa absolute
9	Intake air depression	± 0,05 kPa absolute
10	Atmospheric pressure	± 0,1 kPa absolute
11	Other pressures	± 0,1 kPa absolute
12	Absolute humidity	± 5% of reading
13	Dilution air flow	± 2% of reading
14	Diluted exhaust gas flow	± 2% of reading

1.4. Determination of the gaseous components

1.4.1. General analyser specifications

The analysers shall have a measuring range appropriate for the accuracy required to measure the concentrations of the exhaust gas components (section 1.4.1.1). It is recommended that the analysers be operated in such a way that the measured concentration falls between 15% and 100% of full scale.

If the full scale value is 155 ppm (or ppm C) or less or if read-out systems (computers, data loggers) that provide sufficient accuracy and resolution below 15% of full scale are used, concentrations below 15% of full scale are also acceptable. In this case, additional calibrations are to be made to ensure the accuracy of the calibration curves - Annex III, Appendix 2, section 1.5.5.2.

The electromagnetic compatibility (EMC) of the equipment shall be on a level as to minimize additional errors.

1.4.1.1. Measurement error

The analyzer shall not deviate from the nominal calibration point by more than ± 2% of the reading or ± 0.3% of full scale, whichever is larger.

NOTE: For the purpose of this standard, accuracy is defined as the deviation of the analyzer reading from the nominal calibration values using a calibration gas (≡ true value)

1.4.1.2. Repeatability

The repeatability, defined as 2,5 times the standard deviation of 10 repetitive responses to a given calibration or span gas, must be no greater than ± 1% of full scale

Status: EU Directives are being published on this site to aid cross referencing from UK legislation. After IP completion day (31 December 2020 11pm) no further amendments will be applied to this version.

concentration for each range used above 155 ppm (or ppm C) or $\pm 2\%$ of each range used below 155 ppm (or ppm C).

1.4.1.3. Noise

The analyser peak-to-peak response to zero and calibration or span gases over any 10-second period shall not exceed 2% of full scale on all ranges used.

1.4.1.4. Zero drift

The zero drift during a one-hour period shall be less than 2% of full scale on the lowest range used. The zero response is defined as the mean response, including noise, to a zero gas during a 30-second time interval.

1.4.1.5. Span drift

The span drift during a one-hour period shall be less than 2% of full scale on the lowest range used. Span is defined as the difference between the span response and the zero response. The span response is defined as the mean response, including noise, to a span gas during a 30-second time interval.

1.4.2. Gas drying

The optional gas drying device must have a minimal effect on the concentration of the measured gases. Chemical dryers are not an acceptable method of removing water from the sample.

1.4.3. Analysers

Sections 1.4.3.1 to 1.4.3.5 of this Appendix describe the measurement principles to be used. A detailed description of the measurement systems is given in Annex VI.

The gases to be measured shall be analysed with the following instruments. For non-linear analysers, the use of linearizing circuits is permitted.

1.4.3.1. Carbon monoxide (CO) analysis

The carbon monoxide analyser shall be of the non-dispersive infra-red (NDIR) absorption type.

1.4.3.2. Carbon dioxide (CO₂) analysis

The carbon dioxide analyser shall be of the non-dispersive infra-red (NDIR) absorption type.

1.4.3.3. Hydrocarbon (HC) analysis

The hydrocarbon analyser shall be of the heated flame ionization detector (HFID) type with detector, valves, pipework, etc, heated so as to maintain a gas temperature of 463 K (190°C) ± 10 K.

1.4.3.4. Oxides of nitrogen (NO_x) analysis

The oxides of nitrogen analyser shall be of the chemiluminescent detector (CLD) or heated chemiluminescent detector (HCLD) type with a NO₂/NO converter, if measured on a dry basis. If measured on a wet basis, a HCLD with converter maintained above 328 K (55°C) shall be used, provided the water quench check (Annex III, Appendix 2, section 1.9.2.2) is satisfied.

Status: EU Directives are being published on this site to aid cross referencing from UK legislation. After IP completion day (31 December 2020 11pm) no further amendments will be applied to this version.

For both CLD and HCLD, the sampling path shall be maintained at a wall temperature of 328 K to 473 K (55°C to 200°C) up to the converter for dry measurement, and up to the analyzer for wet measurement.

1.4.4. Air to fuel measurement

The air to fuel measurement equipment used to determine the exhaust gas flow as specified in section 1.2.5 shall be a wide range air to fuel ratio sensor or lambda sensor of Zirconia type.

The sensor shall be mounted directly on the exhaust pipe where the exhaust gas temperature is high enough to eliminate water condensation.

The accuracy of the sensor with incorporated electronics shall be within:

± 3% of reading	$\lambda < 2$	
± 5% of reading	$2 \leq \lambda$	< 5
± 10% of reading	$5 \leq \lambda$	

To fulfil the accuracy specified above, the sensor shall be calibrated as specified by the instrument manufacturer.

1.4.5. Sampling for gaseous emissions

The gaseous emissions sampling probes must be fitted at least 0,5 m or three times the diameter of the exhaust pipe - whichever is the larger - upstream of the exit of the exhaust gas system as far as applicable and sufficiently close to the engine as to ensure an exhaust gas temperature of at least 343 K (70°C) at the probe.

In the case of a multi-cylinder engine with a branched exhaust manifold, the inlet of the probe shall be located sufficiently far downstream so as to ensure that the sample is representative of the average exhaust emissions from all cylinders. In multi-cylinder engines having distinct groups of manifolds, such as in a 'V'-engine configuration, it is permissible to acquire a sample from each group individually and calculate an average exhaust emission. Other methods which have been shown to correlate with the above methods may be used. For exhaust emissions calculation the total exhaust mass flow of the engine must be used.

If the composition of the exhaust gas is influenced by any exhaust after-treatment system, the exhaust sample must be taken upstream of this device in the tests of stage I and downstream of this device in the tests of stage II. When a full flow dilution system is used for the determination of the particulates, the gaseous emissions may also be determined in the diluted exhaust gas. The sampling probes shall be close to the particulate sampling probe in the dilution tunnel (Annex VI, section 1.2.1.2, DT and Section 1.2.2, PSP). CO and CO₂ may optionally be determined by sampling into a bag and subsequent measurement of the concentration in the sampling bag.

1.5. Determination of the particulates

The determination of the particulates requires a dilution system. Dilution may be accomplished by a partial flow dilution system or a full flow dilution system. The flow capacity of the dilution system shall be large enough to completely eliminate water condensation in the dilution and sampling systems, and maintain the temperature of the

Status: EU Directives are being published on this site to aid cross referencing from UK legislation. After IP completion day (31 December 2020 11pm) no further amendments will be applied to this version.

diluted exhaust gas between 315 K (42°C) and 325 K (52°C) immediately upstream of the filter holders. De-humidifying the dilution air before entering the dilution system is permitted, if the air humidity is high. Dilution air pre-heating above the temperature limit of 303 K (30 °C) is recommended, if the ambient temperature is below 293 K (20°C). However, the diluted air temperature must not exceed 325 K (52°C) prior to the introduction of the exhaust in the dilution tunnel.

NOTE: For steady-state procedure, the filter temperature may be kept at or below the maximum temperature of 325 K (52°C) instead of respecting the temperature range of 42°C - 52°C.

For a partial flow dilution system, the particulate sampling probe must be fitted close to and upstream of the gaseous probe as defined in Section 4.4 and in accordance with Annex VI, section 1.2.1.1, figure 4-12 EP and SP.

The partial flow dilution system has to be designed to split the exhaust stream into two fractions, the smaller one being diluted with air and subsequently used for particulate measurement. From that it is essential that the dilution ratio be determined very accurately. Different splitting methods can be applied, whereby the type of splitting used dictates to a significant degree the sampling hardware and procedures to be used (Annex VI, section 1.2.1.1).

To determine the mass of the particulates, a particulate sampling system, particulate sampling filters, a microgram balance and a temperature and humidity controlled weighing chamber are required.

For particulate sampling, two methods may be applied:

- the single filter method uses one pair of filters (1.5.1.3. of this Appendix) for all modes of the test cycle. Considerable attention must be paid to sampling times and flows during the sampling phase of the test. However, only one pair of filters will be required for the test cycle,
- the multiple filter method dictates that one pair of filters (section 1.5.1.3. of this Appendix) is used for each of the individual modes of the test cycle. This method allows more lenient sample procedures but uses more filters.

1.5.1. Particulate sampling filters

1.5.1.1. Filter specification

Fluorocarbon coated glass fibre filters or fluorocarbon based membrane filters are required for certification tests. For special applications different filter materials may be used. All filter types shall have a 0,3 µm DOP (di-octylphthalate) collection efficiency of at least 99% at a gas face velocity between 35 and 100 cm/s. When performing correlation tests between laboratories or between a manufacturer and an approval authority, filters of identical quality must be used.

1.5.1.2. Filter size

Particulate filters must have a minimum diameter of 47 mm (37 mm stain diameter). Larger diameter filters are acceptable (section 1.5.1.5.).

1.5.1.3. Primary and back-up filters

The diluted exhaust shall be sampled by a pair of filters placed in series (one primary and one back-up filter) during the test sequence. The back-up filter shall be located

no more than 100 mm downstream of, and shall not be in contact with, the primary filter. The filters may be weighed separately or as a pair with the filters placed stain side to stain side.

1.5.1.4. Filter face velocity

A gas face velocity through the filter of 35 to 100 cm/s shall be achieved. The pressure drop increase between the beginning and the end of the test shall be no more than 25 kPa.

1.5.1.5. Filter loading

The recommended minimum filter loadings for the most common filter sizes are shown in the following table. For larger filter sizes, the minimum filter loading shall be 0,065 mg/1000 mm² filter area.

Filter Diameter (mm)	Recommended stain diameter (mm)	Recommended minimum loading (mg)
47	37	0,11
70	60	0,25
90	80	0,41
110	100	0,62

For the multiple filter method, the recommended minimum filter loading for the sum of all filters shall be the product of the appropriate value above and the square root of the total number of modes.

1.5.2. Weighing chamber and analytical balance specifications

1.5.2.1. Weighing chamber conditions

The temperature of the chamber (or room) in which the particulate filters are conditioned and weighed shall be maintained to within 295 K (22°C) ± 3K during all filter conditioning and weighing. The humidity shall be maintained to a dew point of 282,5 (9,5°C) ± 3K and a relative humidity of 45 ± 8%.

1.5.2.2. Reference filter weighing

The chamber (or room) environment shall be free of any ambient contaminants (such as dust) that would settle on the particulate filters during their stabilisation. Disturbances to weighing room specifications as outlined in section 1.5.2.1 will be allowed if the duration of the disturbances does not exceed 30 minutes. The weighing room should meet the required specifications prior to personnel entrance into the weighing room. At least two unused reference filters or reference filter pairs shall be weighed within four hours of, but preferably at the same time as the sample filter (pair) weighing. They shall be the same size and material as the sample filters.

If the average weight of the reference filters (reference filter pairs) changes between sample filter weighing by more than 10 µg, then all sample filters shall be discarded and the emissions test repeated.

If the weighing room stability criteria outlined in section 1.5.2.1 is not met, but the reference filter (pair) weighing meet the above criteria, the engine manufacturer

Status: EU Directives are being published on this site to aid cross referencing from UK legislation. After IP completion day (31 December 2020 11pm) no further amendments will be applied to this version.

has the option of accepting the sample filter weights or voiding the tests, fixing the weighing room control system and re-running the test.

1.5.2.3. Analytical balance

The analytical balance used to determine the weights of all filters shall have a precision (standard deviation) of 2 (μg) and a resolution of 1 μg (1 digit = 1 μg) specified by the balance manufacturer.

1.5.2.4. Elimination of static electricity effects

To eliminate the effects of static electricity, the filters shall be neutralized prior to weighing, for example, by a Polonium neutralizer or a device of similar effect.

1.5.3. Additional specifications for particulate measurement

All parts of the dilution system and the sampling system from the exhaust pipe up to the filter holder, which are in contact with raw and diluted exhaust gas, must be designed to minimize deposition or alteration of the particulates. All parts must be made of electrically conductive materials that do not react with exhaust gas components, and must be electrically grounded to prevent electrostatic effects.

2. MEASUREMENT AND SAMPLING PROCEDURES (NRTC TEST)

2.1. Introduction

Gaseous and particulate components emitted by the engine submitted for testing shall be measured by the methods of Annex VI. The methods of Annex VI describe the recommended analytical systems for the gaseous emissions (Section 1.1) and the recommended particulate dilution and sampling systems (Section 1.2).

2.2. Dynamometer and test cell equipment

The following equipment shall be used for emission tests of engines on engine dynamometers:

2.2.1. Engine Dynamometer

An engine dynamometer shall be used with adequate characteristics to perform the test cycle described in Appendix 4 to this Annex. The instrumentation for torque and speed measurement shall allow the measurement of the power within the given limits. Additional calculations may be necessary. The accuracy of the measuring equipment must be such that the maximum tolerances of the figures given in Table 3 are not exceeded.

2.2.2. Other Instruments

Measuring instruments for fuel consumption, air consumption, temperature of coolant and lubricant, exhaust gas pressure and intake manifold depression, exhaust gas temperature, air intake temperature, atmospheric pressure, humidity and fuel temperature shall be used, as required. These instruments shall satisfy the requirements given in Table 3:

TABLE 3. ACCURACY OF MEASURING INSTRUMENTS

No.	Measuring Instrument	Accuracy
-----	----------------------	----------

Status: EU Directives are being published on this site to aid cross referencing from UK legislation. After IP completion day (31 December 2020 11pm) no further amendments will be applied to this version.

1	Engine speed	± 2% of reading or ± 1% of engine's max. value, whichever is larger
2	Torque	± 2% of reading or ± 1% of engine's max. value, whichever is larger
3	Fuel consumption	± 2% of engine's max. value
4	Air consumption	± 2% of reading or ± 1% of engine's max. value, whichever is larger
5	Exhaust gas flow	± 2,5% of reading or ± 1,5% of engine's max. value, whichever is larger
6	Temperatures ≤ 600 K	+ 2K absolute
7	Temperatures > 600 K	± 1% of reading
8	Exhaust gas pressure	± 0,2 kPa absolute
9	Intake air depression	± 0,05 kPa absolute
10	Atmospheric pressure	± 0,1 kPa absolute
11	Other pressures	± 0,1 kPa absolute
12	Absolute humidity	± 5% of reading
13	Dilution air flow	± 2% of reading
14	Diluted exhaust gas flow	± 2% of reading

2.2.3. Raw Exhaust Gas Flow

For calculating the emissions in the raw exhaust gas and for controlling a partial flow dilution system, it is necessary to know the exhaust gas mass flow rate. For determining the exhaust mass flow rate, either of the methods described below may be used.

For the purpose of emissions calculation, the response time of either method described below shall be equal to or less than the requirement for the analyzer response time, as defined in Appendix 2, Section 1.11.1.

For the purpose of controlling a partial flow dilution system, a faster response is required. For partial flow dilution systems with online control, a response time of ≤ 0,3 s is required. For partial flow dilution systems with look ahead control based on a pre-recorded test run, a response time of the exhaust flow measurement system of ≤ 5 s with a rise time of ≤ 1 s is required. The system response time shall be specified by the instrument manufacturer. The combined response time requirements for exhaust gas flow and partial flow dilution system are indicated in Section 2.4.

Direct measurement method

Status: EU Directives are being published on this site to aid cross referencing from UK legislation. After IP completion day (31 December 2020 11pm) no further amendments will be applied to this version.

Direct measurement of the instantaneous exhaust flow may be done by systems, such as:

- pressure differential devices, like flow nozzle, (for details see ISO 5167: 2000)
- ultrasonic flowmeter
- vortex flowmeter.

Precautions shall be taken to avoid measurement errors, which will impact emission value errors. Such precautions include the careful installation of the device in the engine exhaust system according to the instrument manufacturers' recommendations and to good engineering practice. Especially, engine performance and emissions must not be affected by the installation of the device.

The flowmeters shall meet the accuracy specifications of Table 3.

Air and fuel measurement method

This involves measurement of the airflow and the fuel flow with suitable flowmeters. The calculation of the instantaneous exhaust gas flow is as follows:

$$G_{EXHW} = G_{AIRW} + G_{FUEL} \text{ (for wet exhaust mass)}$$

The flowmeters shall meet the accuracy specifications of Table 3, but shall also be accurate enough to also meet the accuracy specifications for the exhaust gas flow.

Tracer measurement method

This involves measurement of the concentration of a tracer gas in the exhaust.

A known amount of an inert gas (e.g. pure helium) shall be injected into the exhaust gas flow as a tracer. The gas is mixed and diluted by the exhaust gas, but must not react in the exhaust pipe. The concentration of the gas shall then be measured in the exhaust gas sample.

In order to ensure complete mixing of the tracer gas, the exhaust gas sampling probe shall be located at least 1 m or 30 times the diameter of the exhaust pipe, whichever is larger, downstream of the tracer gas injection point. The sampling probe may be located closer to the injection point if complete mixing is verified by comparing the tracer gas concentration with the reference concentration when the tracer gas is injected upstream of the engine.

The tracer gas flow rate shall be set so that the tracer gas concentration at engine idle speed after mixing becomes lower than the full scale of the trace gas analyzer.

The calculation of the exhaust gas flow is as follows:

$$G_{EXHW} = \frac{G_T \times \rho_{EXH}}{60 \times (conc_{mix} - conc_0)}$$

where

G_{EXHW}	=	instantaneous exhaust mass flow (kg/s)
G_T	=	tracer gas flow (cm ³ /min)
$conc_{mix}$	=	instantaneous concentration of the tracer gas after mixing (ppm)
ρ_{EXH}	=	density of the exhaust gas (kg/m ³)

$conc_a$ = background concentration of the tracer gas in the intake air (ppm)

The background concentration of the tracer gas ($conc_a$) may be determined by averaging the background concentration measured immediately before the test run and after the test run.

When the background concentration is less than 1% of the concentration of the tracer gas after mixing ($conc_{mix}$) at maximum exhaust flow, the background concentration may be neglected.

The total system shall meet the accuracy specifications for the exhaust gas flow, and shall be calibrated according to Appendix 2, paragraph 1.11.2

Air flow and air to fuel ratio measurement method

This involves exhaust mass calculation from the airflow and the air to fuel ratio. The calculation of the instantaneous exhaust gas mass flow is as follows:

$$G_{EXHW} = G_{AIRW} \times \left(1 + \frac{1}{A/F_{st} \times \lambda}\right)$$

with $A/F_{st} = 14,5$

$$\lambda = \frac{\left(100 \cdot \frac{conc_{CO} \times 10^{-4}}{2} - conc_{HC} \times 10^{-4}\right) + \left(0,45 \cdot \frac{1 - \frac{2 \times conc_{CO} \times 10^{-4}}{3,5 \times conc_{CO_2}}}{1 + \frac{conc_{CO} \times 10^{-4}}{3,5 \times conc_{CO_2}}}\right) \times (conc_{CO_2} + conc_{CO} \times 10^{-4})}{6,9078 \times (conc_{CO_2} + conc_{CO} \times 10^{-4}) + conc_{HC} \times 10^{-4}}$$

where

A/F_{st}	=	stoichiometric air/fuel ratio (kg/kg)
λ	=	relative air /fuel ratio
$conc_{CO_2}$	=	dry CO ₂ concentration (%)
$conc_{CO}$	=	dry CO concentration (ppm)
$conc_{HC}$	=	HC concentration (ppm)

NOTE: The calculation refers to a diesel fuel with a H/C ratio equal to 1.8.

The air flowmeter shall meet the accuracy specifications in Table 3, the CO₂ analyzer used shall meet the specifications of section 2.3.1, and the total system shall meet the accuracy specifications for the exhaust gas flow.

Optionally, air to fuel ratio measurement equipment, such as a zirconia type sensor, may be used for the measurement of the excess air ratio in accordance with the specifications of section 2.3.4.

2.2.4. Diluted Exhaust Gas Flow

For calculation of the emissions in the diluted exhaust gas, it is necessary to know the diluted exhaust gas mass flow rate. The total diluted exhaust gas flow over the cycle (kg/test) shall be calculated from the measurement values over the cycle and the corresponding calibration data of the flow measurement device (V_0 for PDP, K_V for CFV, C_d for SSV): the corresponding methods described in Appendix 3, section 2.2.1 shall be used. If the total sample mass of particulates and gaseous pollutants exceeds 0,5% of the total CVS flow, the CVS flow shall be corrected or the particulate sample flow shall be returned to the CVS prior to the flow measuring device.

2.3. Determination of the gaseous components

Status: EU Directives are being published on this site to aid cross referencing from UK legislation. After IP completion day (31 December 2020 11pm) no further amendments will be applied to this version.

2.3.1. General Analyser Specifications

The analysers shall have a measuring range appropriate for the accuracy required to measure the concentrations of the exhaust gas components (section 1.4.1.1). It is recommended that the analysers be operated in such a way that the measured concentration falls between 15% and 100% of full scale.

If the full scale value is 155 ppm (or ppm C) or less, or if read-out systems (computers, data loggers) that provide sufficient accuracy and resolution below 15% of full scale are used, concentrations below 15% of full scale are also acceptable. In this case, additional calibrations are to be made to ensure the accuracy of the calibration curves - Annex III, Appendix 2, section 1.5.5.2.

The electromagnetic compatibility (EMC) of the equipment shall be of a level such as to minimize additional errors.

2.3.1.1. Measurement error

The analyzer shall not deviate from the nominal calibration point by more than $\pm 2\%$ of the reading or $\pm 0,3\%$ of full scale, whichever is larger.

NOTE: For the purpose of this standard, accuracy is defined as the deviation of the analyzer reading from the nominal calibration values using a calibration gas (\equiv true value).

2.3.1.2. Repeatability

The repeatability, defined as 2,5 times the standard deviation of 10 repetitive responses to a given calibration or span gas, must be no greater than $\pm 1\%$ of full scale concentration for each range used above 155 ppm (or ppm C) or $\pm 2\%$ for each range used below 155 ppm (or ppm C).

2.3.1.3. Noise

The analyser peak-to-peak response to zero and calibration or span gases over any 10-second period shall not exceed 2% of full scale on all ranges used.

2.3.1.4. Zero drift

The zero drift during a one-hour period shall be less than 2% of full scale on the lowest range used. The zero response is defined as the mean response, including noise, to a zero gas during a 30-second time interval.

2.3.1.5. Span drift

The span drift during a one-hour period shall be less than 2% of full scale on the lowest range used. Span is defined as the difference between the span response and the zero response. The span response is defined as the mean response, including noise, to a span gas during a 30-second time interval.

2.3.1.6. Rise Time

For raw exhaust gas analysis, the rise time of the analyzer installed in the measurement system shall not exceed 2,5 s.

NOTE: Only evaluating the response time of the analyzer alone will not clearly define the suitability of the total system for transient testing. Volumes, and especially dead volumes, through out the system will not only affect the transportation time from the

probe to the analyzer, but also affect the rise time. Also transport times inside of an analyzer would be defined as analyzer response time, like the converter or water traps inside of a NO_x analyzers. The determination of the total system response time is described in Appendix 2, Section 1.11.1.

2.3.2. Gas Drying

Same specifications as for NRSC test cycle apply (Section 1.4.2) as described here below.

The optional gas drying device must have a minimal effect on the concentration of the measured gases. Chemical dryers are not an acceptable method of removing water from the sample.

2.3.3. Analysers

Same specifications as for NRSC test cycle apply (Section 1.4.3) as described here below.

The gases to be measured shall be analysed with the following instruments. For non-linear analysers, the use of linearizing circuits is permitted.

2.3.3.1. Carbon monoxide (CO) analysis

The carbon monoxide analyser shall be of the non-dispersive infra-red (NDIR) absorption type.

2.3.3.2. Carbon dioxide (CO₂) analysis

The carbon dioxide analyser shall be of the non-dispersive infra-red (NDIR) absorption type.

2.3.3.3. Hydrocarbon (HC) analysis

The hydrocarbon analyser shall be of the heated flame ionization detector (HFID) type with detector, valves, pipework, etc, heated so as to maintain a gas temperature of 463 K (190°C) ± 10 K.

2.3.3.4. Oxides of nitrogen (NO_x) analysis

The oxides of nitrogen analyser shall be of the chemiluminescent detector (CLD) or heated chemiluminescent detector (HCLD) type with a NO₂/NO converter, if measured on a dry basis. If measured on a wet basis, a HCLD with converter maintained above 328 K (55°C shall be used, provided the water quench check (Annex III, Appendix 2, section 1.9.2.2) is satisfied.

For both CLD and HCLD, the sampling path shall be maintained at a wall temperature of 328 K to 473 K (55°C to 200°C) up to the converter for dry measurement, and up to the analyzer for wet measurement.

2.3.4. Air to fuel measurement

The air to fuel measurement equipment used to determine the exhaust gas flow as specified in section 2.2.3 shall be a wide range air to fuel ratio sensor or lambda sensor of Zirconia type.

The sensor shall be mounted directly on the exhaust pipe where the exhaust gas temperature is high enough to eliminate water condensation.

Status: EU Directives are being published on this site to aid cross referencing from UK legislation. After IP completion day (31 December 2020 11pm) no further amendments will be applied to this version.

The accuracy of the sensor with incorporated electronics shall be within:

± 3 % of reading	$\lambda < 2$	
± 5 % of reading	$2 \leq$	$\lambda < 5$
± 10% of reading	$5 \leq \lambda$	

To fulfil the accuracy specified above, the sensor shall be calibrated as specified by the instrument manufacturer.

2.3.5. Sampling of Gaseous Emissions

2.3.5.1. Raw exhaust gas flow

For calculation of the emissions in the raw exhaust gas the same specifications as for NRSC test cycle apply (Section 1.4.4), as described here below.

The gaseous emissions sampling probes must be fitted at least 0,5 m or three times the diameter of the exhaust pipe -whichever is the larger - upstream of the exit of the exhaust gas system as far as applicable and sufficiently close to the engine as to ensure an exhaust gas temperature of at least 343 K (70°C) at the probe.

In the case of a multicylinder engine with a branched exhaust manifold, the inlet of the probe shall be located sufficiently far downstream so as to ensure that the sample is representative of the average exhaust emissions from all cylinders. In multicylinder engines having distinct groups of manifolds, such as in a 'V'-engine configuration, it is permissible to acquire a sample from each group individually and calculate an average exhaust emission. Other methods which have been shown to correlate with the above methods may be used. For exhaust emissions calculation the total exhaust mass flow of the engine must be used.

If the composition of the exhaust gas is influenced by any exhaust after-treatment system, the exhaust sample must be taken upstream of this device in the tests of stage I and downstream of this device in the tests of stage II.

2.3.5.2. Diluted exhaust gas flow

If a full flow dilution system is used, the following specifications apply.

The exhaust pipe between the engine and the full flow dilution system shall conform to the requirements of Annex VI.

The gaseous emissions sample probe(s) shall be installed in the dilution tunnel at a point where the dilution air and exhaust gas are well mixed, and in close proximity to the particulates sampling probe.

Sampling can generally be done in two ways:

- the pollutants are sampled into a sampling bag over the cycle and measured after completion of the test;
- the pollutants are sampled continuously and integrated over the cycle; this method is mandatory for HC and NO_x.

The background concentrations shall be sampled upstream of the dilution tunnel into a sampling bag, and shall be subtracted from the emissions concentration according to Appendix 3, Section 2.2.3.

2.4. Determination of the particulates

Determination of the particulates requires a dilution system. Dilution may be accomplished by a partial flow dilution system or a full flow dilution system. The flow capacity of the dilution system shall be large enough to completely eliminate water condensation in the dilution and sampling systems, and maintain the temperature of the diluted exhaust gas between 315 K (42°C) and 325 K (52°C) immediately upstream of the filter holders. De-humidifying the dilution air before entering the dilution system is permitted, if the air humidity is high. Dilution air pre-heating above the temperature limit of 303 K (30 °C) is recommended if the ambient temperature is below 293 K (20 °C). However, the diluted air temperature must not exceed 325 K (52°C) prior to the introduction of the exhaust in the dilution tunnel.

The particulate sampling probe shall be installed in close proximity to the gaseous emissions sampling probe, and the installation shall comply with the provisions of Section 2.3.5.

To determine the mass of the particulates, a particulate sampling system, particulate sampling filters, microgram balance, and a temperature and humidity controlled weighing chamber, are required.

Partial flow dilution system specifications

The partial flow dilution system has to be designed to split the exhaust stream into two fractions, the smaller one being diluted with air and subsequently used for particulate measurement. For this it is essential that the dilution ratio be determined very accurately. Different splitting methods can be applied, whereby the type of splitting used dictates to a significant degree the sampling hardware and procedures to be used (Annex VI, section 1.2.1.1).

For the control of a partial flow dilution system, a fast system response is required. The transformation time for the system shall be determined by the procedure described in Appendix 2, Section 1.11.1.

If the combined transformation time of the exhaust flow measurement (see previous Section) and the partial flow system is less than 0,3 s, online control may be used. If the transformation time exceeds 0,3 s, look ahead control based on a pre-recorded test run must be used. In this case, the rise time shall be ≤ 1 s and the delay time of the combination ≤ 10 s.

The total system response shall be designed as to ensure a representative sample of the particulates, G_{SE} , proportional to the exhaust mass flow. To determine the proportionality, a regression analysis of G_{SE} versus G_{EXHW} shall be conducted on a minimum 5 Hz data acquisition rate, and the following criteria shall be met:

- The correlation coefficient r^2 of the linear regression between G_{SE} and G_{EXHW} shall be not less than 0,95.
- The standard error of estimate of G_{SE} on G_{EXHW} shall not exceed 5% of G_{SE} maximum.
- G_{SE} intercept of the regression line shall not exceed $\pm 2\%$ of G_{SE} maximum.

Optionally, a pre-test may be run, and the exhaust mass flow signal of the pre-test be used for controlling the sample flow into the particulate system ("look-ahead control"). Such a procedure is required if the transformation time of the particulate system, $t_{50,P}$

Status: EU Directives are being published on this site to aid cross referencing from UK legislation. After IP completion day (31 December 2020 11pm) no further amendments will be applied to this version.

or/and the transformation time of the exhaust mass flow signal, $t_{50,F}$ are $> 0,3$ s. A correct control of the partial dilution system is obtained, if the time trace of $G_{EXHW,pre}$ of the pre-test, which controls G_{SE} , is shifted by a "look-ahead" time of $t_{50,P} + t_{50,F}$.

For establishing the correlation between G_{SE} and G_{EXHW} the data taken during the actual test shall be used, with G_{EXHW} time aligned by $t_{50,F}$ relative to G_{SE} (no contribution from $t_{50,P}$ to the time alignment). That is, the time shift between G_{EXHW} and G_{SE} is the difference in their transformation times that were determined in Appendix 2, Section 2.6.

For partial flow dilution systems, the accuracy of the sample flow G_{SE} is of special concern, if not measured directly, but determined by differential flow measurement:

$$G_{SE} = G_{TOTW} - G_{DILW}$$

In this case an accuracy of $\pm 2\%$ for G_{TOTW} and G_{DILW} is not sufficient to guarantee acceptable accuracies of G_{SE} . If the gas flow is determined by differential flow measurement, the maximum error of the difference shall be such that the accuracy of G_{SE} is within $\pm 5\%$ when the dilution ratio is less than 15. It can be calculated by taking root-mean-square of the errors of each instrument.

Acceptable accuracies of G_{SE} can be obtained by either of the following methods:

- (a) The absolute accuracies of G_{TOTW} and G_{DILW} are $\pm 0,2\%$ which guarantees an accuracy of G_{SE} of $\leq 5\%$ at a dilution ratio of 15. However, greater errors will occur at higher dilution ratios.
- (b) Calibration of G_{DILW} relative to G_{TOTW} is carried out such that the same accuracies for G_{SE} as in (a) are obtained. For the details of such a calibration see Appendix 2, Section 2.6.
- (c) The accuracy of G_{SE} is determined indirectly from the accuracy of the dilution ratio as determined by a tracer gas, e.g. CO_2 . Again, accuracies equivalent to method (a) for G_{SE} are required.
- (d) The absolute accuracy of G_{TOTW} and G_{DILW} is within $\pm 2\%$ of full scale, the maximum error of the difference between G_{TOTW} and G_{DILW} is within $0,2\%$, and the linearity error is within $\pm 0.2\%$ of the highest G_{TOTW} observed during the test.

2.4.1. Particulate Sampling Filters

2.4.1.1. Filter specification

Fluorocarbon coated glass fibre filters or fluorocarbon based membrane filters are required for certification tests. For special applications different filter materials may be used. All filter types shall have a $0,3 \mu m$ DOP (di-octylphthalate) collection efficiency of at least 99% at a gas face velocity between 35 and 100 cm/s. When performing correlation tests between laboratories or between a manufacturer and an approval authority, filters of identical quality must be used.

2.4.1.2. Filter size

Particulate filters must have a minimum diameter of 47 mm (37 mm stain diameter). Larger diameter filters are acceptable (section 2.4.1.5.).

2.4.1.3. Primary and back-up filters

The diluted exhaust shall be sampled by a pair of filters placed in series (one primary and one back-up filter) during the test sequence. The back-up filter shall be located no more than 100 mm downstream of, and shall not be in contact with, the primary filter. The filters may be weighed separately or as a pair with the filters placed stain side to stain side.

2.4.1.4. Filter face velocity

A gas face velocity through the filter of 35 to 100 cm/s shall be achieved. The pressure drop increase between the beginning and the end of the test shall be no more than 25 kPa.

2.4.1.5. Filter loading

The recommended minimum filter loadings for the most common filter sizes are shown in the following table. For larger filter sizes, the minimum filter loading shall be 0,065 mg/1000 mm² filter area.

Filter Diameter (mm)	Recommended stain diameter (mm)	Recommended minimum loading (mg)
47	37	0,11
70	60	0,25
90	80	0,41
110	100	0,62

2.4.2. Weighing Chamber and Analytical Balance Specifications

2.4.2.1. Weighing chamber conditions

The temperature of the chamber (or room) in which the particulate filters are conditioned and weighed shall be maintained to within 295 K (22°C) ±3K during all filter conditioning and weighing. The humidity shall be maintained to a dewpoint of 282,5 (9,5°C) ± 3 K and a relative humidity of 45 ± 8%.

2.4.2.2. Reference filter weighing

The chamber (or room) environment shall be free of any ambient contaminants (such as dust) that would settle on the particulate filters during their stabilisation. Disturbances to weighing room specifications as outlined in section 2.4.2.1 will be allowed if the duration of the disturbances does not exceed 30 minutes. The weighing room should meet the required specifications prior to personnel entrance into the weighing room. At least two unused reference filters or reference filter pairs shall be weighed within four hours of, but preferably at the same time as the sample filter (pair) weighing. They shall be the same size and material as the sample filters.

If the average weight of the reference filters (reference filter pairs) changes between sample filter weighing by more than 10µg, then all sample filters shall be discarded and the emissions test repeated.

Status: EU Directives are being published on this site to aid cross referencing from UK legislation. After IP completion day (31 December 2020 11pm) no further amendments will be applied to this version.

If the weighing room stability criteria outlined in section 2.4.2.1 are not met, but the reference filter (pair) weighing meet the above criteria, the engine manufacturer has the option of accepting the sample filter weights or voiding the tests, fixing the weighing room control system and re-running the test.

2.4.2.3. Analytical balance

The analytical balance used to determine the weights of all filters shall have a precision (standard deviation) of 2 (µg and a resolution of 1 µg (1 digit = 1 µg) specified by the balance manufacturer.

2.4.2.4. Elimination of static electricity effects

To eliminate the effects of static electricity, the filters shall be neutralized prior to weighing, for example, by a Polonium neutralizer or a device having similar effect.

2.4.3. Additional Specifications for Particulate Measurement

All parts of the dilution system and the sampling system from the exhaust pipe up to the filter holder, which are in contact with raw and diluted exhaust gas, must be designed to minimize deposition or alteration of the particulates. All parts must be made of electrically conductive materials that do not react with exhaust gas components, and must be electrically grounded to prevent electrostatic effects.”

6) Appendix 2 shall be amended as follows:

(a) The title shall be amended as follows:
APPENDIX 2 CALIBRATION PROCEDURE (NRSC, NRTC⁽¹⁶⁾)

(b) Section 1.2.2 shall be amended as follows:

After the current text the following shall be added:

This accuracy implies that primary gases used for blending shall be known to have an accuracy of at least $\pm 1\%$, traceable to national or international gas standards. The verification shall be performed at between 15 and 50% of full scale for each calibration incorporating a blending device. An additional verification may be performed using another calibration gas, if the first verification has failed.

Optionally, the blending device may be checked with an instrument which by nature is linear, e.g. using NO gas with a CLD. The span value of the instrument shall be adjusted with the span gas directly connected to the instrument. The blending device shall be checked at the used settings and the nominal value shall be compared to the measured concentration of the instrument. This difference shall in each point be within $\pm 1\%$ of the nominal value.

Other methods may be used based on good engineering practice and with the prior agreement of the parties involved.

NOTE: A precision gas divider of accuracy is within $\pm 1\%$, is recommended for establishing the accurate analyzer calibration curve. The gas divider shall be calibrated by the instrument manufacturer.

(c) section 1.5.5.1 shall be amended as follows:

- (i) the first sentence shall be replaced by the following:
- The analyser calibration curve is established by at least six calibration points (excluding zero) spaced as uniformly as possible.
- (ii) the third indent shall be replaced by the following:
- The calibration curve must not differ by more than $\pm 2\%$ from the nominal value of each calibration point and by more than $\pm 0,3\%$ of full scale at zero.
- (d) in section 1.5.5.2, the last indent shall be replaced by the following:
- The calibration curve must not differ by more than $\pm 4\%$ from the nominal value of each calibration point and by more than $\pm 0,3\%$ of full scale at zero.
- (e) the text under section 1.8.3 shall be replaced by the following:
- The oxygen interference check shall be determined when introducing an analyser into service and after major service intervals.
- A range shall be chosen where the oxygen interference check gases will fall within the upper 50%. The test shall be conducted with the oven temperature set as required.

1.8.3.1. Oxygen interference gases

Oxygen interference check gases shall contain propane with 350 ppmC \div 75 ppmC hydrocarbon. The concentration value shall be determined to calibration gas tolerances by chromatographic analysis of total hydrocarbons plus impurities or by dynamic blending. Nitrogen shall be the predominant diluent with the balance oxygen. Blends required for Diesel engine testing are:

O ₂ concentration	Balance
21 (20 to 22)	Nitrogen
10 (9 to 11)	Nitrogen
5 (4 to 6)	Nitrogen

1.8.3.2. Procedure

- (a) The analyzer shall be zeroed.
- (b) The analyzer shall be spanned with the 21% oxygen blend.
- (c) The zero response shall be rechecked. If it has changed more than 0,5% of full scale clauses (a) and (b) shall be repeated.
- (d) The 5% and 10% oxygen interference check gases shall be introduced.

Status: EU Directives are being published on this site to aid cross referencing from UK legislation. After IP completion day (31 December 2020 11pm) no further amendments will be applied to this version.

(e) The zero response shall be rechecked. If it has changed more than $\pm 1\%$ of full scale, the test shall be repeated.

(f) The oxygen interference (%O₂I) shall be calculated for each mixture in (d) as follows:

$$O_2I = \frac{(B-C)}{B} \cdot 100$$

A = hydrocarbon concentration (ppmC) of the span gas used in (b)

B = hydrocarbon concentration (ppmC) of the oxygen interference check gases used in (d)

C = analyzer response

$$(ppmC) = \frac{A}{D}$$

D = percent of full scale analyzer response due to A.

(g) The % of oxygen interference (%O₂I) shall be less than $\pm 3,0\%$ for all required oxygen interference check gases prior to testing.

(h) If the oxygen interference is greater than $\pm 3,0\%$, the air flow above and below the manufacturer's specifications shall be incrementally adjusted, repeating clause 1.8.1 for each flow.

(i) If the oxygen interference is greater than $\pm 3,0\%$ after adjusting the air flow, the fuel flow and thereafter the sample flow shall be varied, repeating clause 1.8.1 for each new setting.

(j) If the oxygen interference is still greater than $\pm 3,0\%$, the analyzer, FID fuel, or burner air shall be repaired or replaced prior to testing. This clause shall then be repeated with the repaired or replaced equipment or gases.

(f) Current paragraph 1.9.2.2 shall be amended as follows:

(i) the first subparagraph shall be replaced by the following:

This check applies to wet gas concentration measurements only. Calculation of water quench must consider dilution of the NO span gas with water vapour and scaling of water vapour concentration of the mixture to that expected during testing. A NO span gas having a concentration of 80 to 100% of full scale to the normal operating range shall be passed through the (H)CLD and the NO value recorded as D. The NO gas shall be bubbled through water at room temperature and passed through the (H)CLD and NO value recorded as C. The water temperature shall be determined and recorded as F. The mixture's saturation vapour pressure that corresponds to the

bubbler water temperature (F) shall be determined and recorded as G. The water vapour concentration (in %) of the mixture shall be calculated as follows:

- (ii) The third subparagraph shall be replaced by the following:

"and recorded as De. For diesel exhaust, the maximum exhaust water vapour concentration (in %) expected during testing shall be estimated, under the assumption of a fuel atom H/C ratio of 1,8 to 1, from the maximum CO₂ concentration in the exhaust gas or from the undiluted CO₂ span gas concentration (A, as measured in section 1.9.2.1) as follows:

- (g) the following section shall be inserted:

1.11. Additional calibration requirements for raw exhaust measurements over NRTC test

1.11.1. Response time check of the analytical system

The system settings for the response time evaluation shall be exactly the same as during measurement of the test run (i.e. pressure, flow rates, filter settings on the analyzers and all other response time influences). The response time determination shall be done with gas switching directly at the inlet of the sample probe. The gas switching shall be done in less than 0,1 second. The gases used for the test shall cause a concentration change of at least 60% FS.

The concentration trace of each single gas component shall be recorded. The response time is defined as the difference in time between the gas switching and the appropriate change of the recorded concentration. The system response time (t_{90}) consists of the delay time to the measuring detector and the rise time of the detector. The delay time is defined as the time from the change (t_0) until the response is 10% of the final reading (t_{10}). The rise time is defined as the time between 10% and 90% response of the final reading ($t_{90} - t_{10}$).

For time alignment of the analyzer and exhaust flow signals in the case of raw measurement, the transformation time is defined as the time from the change (t_0) until the response is 50% of the final reading (t_{50}).

The system response time shall be = 10 seconds with a rise time = 2,5 seconds for all limited components (CO, NO_x, HC) and all ranges used.

1.11.2. Calibration of tracer gas analyzer for exhaust flow measurement

The analyzer for measurement of the tracer gas concentration, if used, shall be calibrated using the standard gas.

The calibration curve shall be established by at least 10 calibration points (excluding zero) spaced so that a half of the calibration points are placed between 4% to 20% of analyzer's full scale and the rest are in between 20% to 100% of the full scale. The calibration curve is calculated by the method of least squares.

The calibration curve shall not differ by more than $\pm 1\%$ of the full scale from the nominal value of each calibration point, in the range from 20% to

Status: EU Directives are being published on this site to aid cross referencing from UK legislation. After IP completion day (31 December 2020 11pm) no further amendments will be applied to this version.

100% of the full scale. It shall also not differ by more than $\pm 2\%$ from the nominal value in the range from 4% to 20% of the full scale.

The analyzer shall be set at zero and spanned prior to the test run using a zero gas and a span gas whose nominal value is more than 80% of the analyzer full scale.

(h) paragraph 2.2 shall be replaced by the following:

2.2. The calibration of gas flow-meters or flow measurement instrumentation shall be traceable to national and/or international standards.

The maximum error of the measured value shall be within $\pm 2\%$ of reading.

For partial flow dilution systems, the accuracy of the sample flow G_{SE} is of special concern, if not measured directly, but determined by differential flow measurement:

$$G_{SE} = G_{TOTW} - G_{DILW}$$

In this case an accuracy of $\pm 2\%$ for G_{TOTW} and G_{DILW} is not sufficient to guarantee acceptable accuracies of G_{SE} . If the gas flow is determined by differential flow measurement, the maximum error of the difference shall be such that the accuracy of G_{SE} is within $\pm 5\%$ when the dilution ratio is less than 15. It can be calculated by taking root-mean-square of the errors of each instrument.

(i) the following section shall be added:

2.6. Additional calibration requirements for partial flow dilution systems

2.6.1. Periodical calibration

If the sample gas flow is determined by differential flow measurement the flow meter or the flow measurement instrumentation shall be calibrated by one of the following procedures, such that the probe flow G_{SE} into the tunnel fulfils the accuracy requirements of Appendix I section 2.4:

The flow meter for G_{DILW} is connected in series to the flow meter for G_{TOTW} , the difference between the two flow meters is calibrated for at least 5 set points with flow values equally spaced between the lowest G_{DILW} value used during the test and the value of G_{TOTW} used during the test. The dilution tunnel may be bypassed.

A calibrated mass flow device is connected in series to the flowmeter for G_{TOTW} and the accuracy is checked for the value used for the test. Then the calibrated mass flow device is connected in series to the flow meter for G_{DILW} , and the accuracy is checked for at least 5 settings corresponding to the dilution ratio between 3 and 50, relative to G_{TOTW} used during the test.

The transfer tube TT is disconnected from the exhaust, and a calibrated flow measuring device with a suitable range to measure G_{SE} is connected to the transfer tube. Then G_{TOTW} is set to the value used during the test, and G_{DILW} is sequentially set to at least 5 values corresponding to dilution ratios q between

3 and 50. Alternatively, a special calibration flow path may be provided, in which the tunnel is bypassed, but the total and dilution air flow through the corresponding meters are maintained as in the actual test.

A tracer gas is fed into the transfer tube TT. This tracer gas may be a component of the exhaust gas, like CO₂ or NO_x. After dilution in the tunnel the tracer gas component is measured. This shall be carried out for 5 dilution ratios between 3 and 50. The accuracy of the sample flow is determined from the dilution ratio q :

$$G_{SE} = G_{TOTW}/q$$

The accuracies of the gas analyzers shall be taken into account to guarantee the accuracy of G_{SE}

2.6.2. Carbon flow check

A carbon flow check using actual exhaust is strongly recommended for detecting measurement and control problems and verifying the proper operation of the partial flow dilution system. The carbon flow check should be run at least each time a new engine is installed, or something significant is changed in the test cell configuration.

The engine shall be operated at peak torque load and speed or any other steady-state mode that produces 5% or more of CO₂. The partial flow sampling system shall be operated with a dilution factor of about 15 to 1.

2.6.3. Pre-test check

A pre-test check shall be performed within 2 hours before the test run in the following way:

The accuracy of the flow meters shall be checked by the same method as used for calibration for at least two points, including flow values of G_{DILW} that correspond to dilution ratios between 5 and 15 for the G_{TOTW} value used during the test.

If it can be demonstrated by records of the calibration procedure described above that the flow meter calibration is stable over a longer period of time, the pre-test check may be omitted.

2.6.4. Determination of the transformation time

The system settings for the transformation time evaluation shall be exactly the same as during measurement of the test run. The transformation time shall be determined by the following method:

An independent reference flowmeter with a measurement range appropriate for the probe flow shall be put in series with and closely coupled to the probe. This flow meter shall have a transformation time of less than 100 ms for the flow step size used in the response time measurement, with flow restriction sufficiently low not to affect the dynamic performance of the partial flow dilution system, and consistent with good engineering practice.

A step change shall be introduced to the exhaust flow (or air flow if exhaust flow is calculated) input of the partial flow dilution system, from a low flow to at least 90% of full scale. The trigger for the step change should be the

Status: EU Directives are being published on this site to aid cross referencing from UK legislation. After IP completion day (31 December 2020 11pm) no further amendments will be applied to this version.

same one as that used to start the look-ahead control in actual testing. The exhaust flow step stimulus and the flowmeter response shall be recorded at a sample rate of at least 10 Hz.

From this data, the transformation time shall be determined for the partial flow dilution system, which is the time from the initiation of the step stimulus to the 50% point of the flowmeter response. In a similar manner, the transformation times of the G_{SE} signal of the partial flow dilution system and of the G_{EXHW} signal of the exhaust flow meter shall be determined. These signals are used in the regression checks performed after each test (Appendix I section 2.4).

The calculation shall be repeated for at least 5 rise and fall stimuli, and the results shall be averaged. The internal transformation time (<100 ms) of the reference flowmeter shall be subtracted from this value. This is the "look-ahead" value of the partial flow dilution system, which shall be applied in accordance with Appendix I section 2.4.

7) the following section shall be added:

3. CALIBRATION OF THE CVS SYSTEM

3.1. General

The CVS system shall be calibrated by using an accurate flowmeter and means to change operating conditions.

The flow through the system shall be measured at different flow operating settings, and the control parameters of the system shall be measured and related to the flow.

Various type of flowmeters may be used, e.g. calibrated venturi, calibrated laminar flowmeter, calibrated turbinometer.

3.2. Calibration of the Positive Displacement Pump (PDP)

All the parameters related to the pump shall be simultaneously measured along with the parameters related to a calibration venturi which is connected in series with the pump. The calculated flow rate (in m³/min at pump inlet, absolute pressure and temperature) shall be plotted against a correlation function which is the value of a specific combination of pump parameters. The linear equation which relates the pump flow and the correlation function shall be determined. If a CVS has a multiple speed drive, the calibration shall be performed for each range used.

Temperature stability shall be maintained during calibration.

Leaks in all the connections and ducting between the calibration venturi and the CVS pump shall be maintained lower than 0,3% of the lowest flow point (highest restriction and lowest PDP speed point).

3.2.1. Data Analysis

The air flowrate (Q_s) at each restriction setting (minimum 6 settings) shall be calculated in standard m³/min from the flowmeter data using the manufacturer's prescribed method. The air flow rate shall then be converted to pump flow (V_0) in m³/rev at absolute pump inlet temperature and pressure as follows:

$$V_0 = \frac{Q_s}{n} \times \frac{T}{273} \times \frac{101.3}{P_A}$$

Status: EU Directives are being published on this site to aid cross referencing from UK legislation. After IP completion day (31 December 2020 11pm) no further amendments will be applied to this version.

where,

Q_s	=	air flow rate at standard conditions (101,3 kPa, 273 K) (m ³ /s)
T	=	temperature at pump inlet (K)
p_A	=	absolute pressure at pump inlet ($p_B - p_1$) (kPa)
n	=	pump speed (rev/s)

To account for the interaction of pressure variations at the pump and the pump slip rate, the correlation function (X_0) between pump speed, pressure differential from pump inlet to pump outlet and absolute pump outlet pressure shall be calculated as follows:

$$X_0 = \frac{1}{n} x \sqrt{\frac{\Delta p_p}{p_A}}$$

where,

Δp_p	=	pressure differential from pump inlet to pump outlet (kPa)
p_A	=	absolute outlet pressure at pump outlet (kPa)

A linear least-square fit shall be performed to generate the calibration equation as follows:

$$V_0 = D_0 - m x (X_0)$$

D_0 and m are the intercept and slope constants, respectively, describing the regression lines.

For a CVS system with multiple speeds, the calibration curves generated for the different pump flow ranges shall be approximately parallel, and the intercept values (D_0) shall increase as the pump flow range decreases.

The values calculated by the equation shall be within $\pm 0,5\%$ of the measured value of V_0 . Values of m will vary from one pump to another. Particulate influx over time will cause the pump slip to decrease, as reflected by lower values for m . Therefore, calibration shall be performed at pump start-up, after major maintenance, and if the total system verification (section 3.5) indicates a change in the slip rate.

3.3. Calibration of the Critical Flow Venturi (CFV)

Calibration of the CFV is based upon the flow equation for a critical venturi. Gas flow is a function of inlet pressure and temperature, as shown below:

$$Q_s = \frac{K_v p_A}{\sqrt{T}}$$

where,

K_v	=	calibration coefficient
p_A	=	absolute pressure at venturi inlet (kPa)
T	=	temperature at venturi inlet (K)

3.3.1. Data Analysis

The air flow rate (Q_s) at each restriction setting (minimum 8 settings) shall be calculated in standard m³/min from the flowmeter data using the manufacturer's prescribed method. The calibration coefficient shall be calculated from the calibration data for each setting as follows:

Status: EU Directives are being published on this site to aid cross referencing from UK legislation. After IP completion day (31 December 2020 11pm) no further amendments will be applied to this version.

$$K_v = \frac{Q_s \sqrt{T}}{P_A}$$

where,

Q_s	=	air flow rate at standard conditions (101,3 kPa, 273 K) (m ³ /s)
T	=	temperature at the venturi inlet (K)
P_A	=	absolute pressure at venturi inlet (kPa)

To determine the range of critical flow, K_v shall be plotted as a function of venturi inlet pressure. For critical (choked) flow, K_v will have a relatively constant value. As pressure decreases (vacuum increases), the venturi becomes unchoked and K_v decreases, which indicates that the CFV is operated outside the permissible range.

For a minimum of eight points in the region of critical flow, the average K_v and the standard deviation shall be calculated. The standard deviation shall not exceed $\pm 0,3\%$ of the average K_v

3.4. Calibration of the Subsonic Venturi (SSV)

Calibration of the SSV is based upon the flow equation for a subsonic venturi. Gas flow is a function of inlet pressure and temperature, pressure drop between the SSV inlet and throat, as shown below:

$$Q_{SSV} = A_0 d^2 C_d P_A \sqrt{\left[\frac{1}{T} (r^{1,4286} - r^{1,7143}) \left(\frac{1}{1 - r^{4,4286}} \right) \right]}$$

where,

A_0	=	collection of constants and units conversions = 0,006111 in SI units $\left(\frac{\text{m}^3}{\text{min}} \right) \left(\frac{\text{K}^{\frac{1}{2}}}{\text{kPa}} \right) \left(\frac{1}{\text{mm}^2} \right)$
d	=	diameter of the SSV throat (m)
C_d	=	discharge coefficient of the SSV
P_A	=	absolute pressure at venturi inlet (kPa)
T	=	temperature at the venturi inlet (K)
r	=	ratio of the SSV throat to inlet absolute, static pressure = $\frac{1 - \frac{\Delta P}{P_A}}{\beta}$
β	=	ratio of the SSV throat diameter, d , to the inlet pipe inner diameter = $\frac{d}{D}$

3.4.1. Data Analysis

The air flow rate (Q_{SSV}) at each flow setting (minimum 16 settings) shall be calculated in standard m³/min from the flowmeter data using the manufacturer's prescribed method. The discharge coefficient shall be calculated from the calibration data for each setting as follows:

$$C_d = \frac{Q_{SSV}}{A_0 d^2 P_A \sqrt{\left[\frac{1}{T} (r^{1,4286} - r^{1,7143}) \left(\frac{1}{1 - r^{4,4286}} \right) \right]}}$$

Status: EU Directives are being published on this site to aid cross referencing from UK legislation. After IP completion day (31 December 2020 11pm) no further amendments will be applied to this version.

where,

$$\begin{aligned}
 Q_{SSV} &= \text{air flow rate at standard conditions (101,3 kPa, 273 K),} \\
 &\quad \text{m}^3/\text{s} \\
 T &= \text{temperature at the venturi inlet, K} \\
 d &= \text{diameter of the SSV throat, m} \\
 r &= \text{ratio of the SSV throat to inlet absolute, static pressure} \\
 &= \\
 &\quad \frac{1 - \frac{\Delta P}{P_A}}{\beta} \\
 \beta &= \text{ratio of the SSV throat diameter, d, to the inlet pipe} \\
 &\quad \text{inner diameter} = \\
 &\quad \frac{d}{D}
 \end{aligned}$$

To determine the range of subsonic flow, C_d shall be plotted as a function of Reynolds number, at the SSV throat. The Re at the SSV throat is calculated with the following formula:

$$Re = A_1 \frac{Q_{SSV}}{d^3}$$

where,

$$\begin{aligned}
 A_1 &= \text{a collection of constants and units conversions} \\
 &= 25,55152 \left(\frac{1}{\text{m}^3} \right) \left(\frac{\text{min}}{\text{s}} \right) \left(\frac{\text{mm}}{\text{m}} \right) \\
 Q_{SSV} &= \text{air flow rate at standard conditions (101,3 kPa, 273 K)} \\
 &\quad \text{(m}^3/\text{s)} \\
 d &= \text{diameter of the SSV throat (m)} \\
 \mu &= \text{absolute or dynamic viscosity of the gas, calculated} \\
 &\quad \text{with the following formula:} \\
 &\quad \mu = \frac{bT^{a/2}}{S+T} = \frac{bT^{a/2}}{1+\frac{S}{T}} \text{ kg/m-s}
 \end{aligned}$$

where:

$$\begin{aligned}
 b &= \text{empirical constant} = \\
 &\quad \frac{1,458 \cdot 10^6 \text{ kg}}{\text{m} \cdot \text{K}^{\frac{1}{2}}} \\
 S &= \text{empirical constant} = 110,4 \text{ K}
 \end{aligned}$$

Because Q_{SSV} is an input to the Re formula, the calculations must be started with an initial guess for Q_{SSV} or C_d of the calibration venturi, and repeated until Q_{SSV} converges. The convergence method must be accurate to 0,1% or better.

For a minimum of sixteen points in the subsonic flow region, the calculated values of C_d from the resulting calibration curve fit equation must be within $\pm 0,5\%$ of the measured C_d for each calibration point.

3.5. Total System Verification

The total accuracy of the CVS sampling system and analytical system shall be determined by introducing a known mass of a pollutant gas into the system while it is being operated in the normal manner. The pollutant is analysed, and the mass calculated according to Annex III, Appendix 3, section 2.4.1 except in the case of propane where a factor of 0,000472 is used in place of 0,000479 for HC. Either of the following two techniques shall be used.

Status: EU Directives are being published on this site to aid cross referencing from UK legislation. After IP completion day (31 December 2020 11pm) no further amendments will be applied to this version.

3.5.1. Metering with a Critical Flow Orifice

A known quantity of pure gas (propane) shall be fed into the CVS system through a calibrated critical orifice. If the inlet pressure is high enough, the flow rate, which is adjusted by means of the critical flow orifice, is independent of the orifice outlet pressure (critical flow). The CVS system shall be operated as in a normal exhaust emission test for about 5 to 10 minutes. A gas sample shall be analysed with the usual equipment (sampling bag or integrating method), and the mass of the gas calculated. The mass so determined shall be within $\pm 3\%$ of the known mass of the gas injected.

3.5.2. Metering by Means of a Gravimetric Technique

The weight of a small cylinder filled with propane shall be determined with a precision of $\pm 0,01$ g. For about 5 to 10 minutes, the CVS system shall be operated as in a normal exhaust emission test, while carbon monoxide or propane is injected into the system. The quantity of pure gas discharged shall be determined by means of differential weighing. A gas sample shall be analysed with the usual equipment (sampling bag or integrating method), and the mass of the gas calculated. The mass so determined shall be within $\pm 3\%$ of the known mass of the gas injected.

8) Appendix 3 shall be amended as follows:

(a) The following title for this Appendix shall be inserted: "DATA EVALUATION AND CALCULATIONS"

(b) the title of section 1 shall read "DATA EVALUATION AND CALCULATIONS - NRSC TEST"

(c) section 1.2 shall be replaced by the following:

1.2 Participate emissions

For the evaluation of the particulates, the total sample masses ($MSAM,i$) through the filters shall be recorded for each mode. The filters shall be returned to the weighing chamber and conditioned for at least one hour, but not more than 80 hours, and then weighed. The gross weight of the filters shall be recorded and the tare weight (see section 3.1, Annex III) subtracted. The particulate mass (M_f for single filter method; $M_{f,i}$ for the multiple filter method) is the sum of the particulate masses collected on the primary and back-up filters. If background correction is to be applied, the dilution air mass ($MDIL$) through the filters and the particulate mass (M_d) shall be recorded. If more than one measurement was made, the quotient $M_d/MDIL$ must be calculated for each single measurement and the values averaged.

(d) section 1.3.1 shall be replaced by the following:

1.3.1 Determination of the exhaust gas flow

The exhaust gas flow rate ($G_{EXHW,}$) shall be determined for each mode according to Annex III, Appendix 1, sections 1.2.1 to 1.2.3.

When using a full flow dilution system, the total dilute exhaust gas flow rate ($G_{TOTW,}$) shall be determined for each mode according to Annex III, Appendix 1, section 1.2.4.

(e) sections 1.3.2 -1.4.6 shall be replaced by the following:

1.3.2. Dry/wet correction (G_{EXHW}) shall be determined for each mode according to Annex III, Appendix 1, sections 1.2.1 to 1.2.3.

When applying G_{EXHW} the measured concentration shall be converted to a wet basis according to the following formulae, if not already measured on a wet basis:

$$\text{conc (wet)} = k_w \times \text{conc (dry)}$$

For the raw exhaust gas:

$$K_{W,r,1} = \left(\frac{1}{1 + 1,88 \times 0,005 \times (\%CO / dry) + \%CO_2 / dry} + K_{w2} \right)$$

For the diluted gas:

$$K_{W,d,1} = \left(1 - \frac{1,88 \times CO_2 \% (wet)}{200} \right) \cdot K_{W1}$$

or:

$$K_{W,r,1} = \left(\frac{1 - K_{W1}}{1 + \frac{1,88 \times CO_2 \% (dry)}{200}} \right)$$

For the dilution air:

$$k_{W,d} = 1 - k_{W1}$$

$$k_{W1} = \frac{1,608 \times [H_d \times (1 - 1 / DF) + H_a \times (1 / DF)]}{1000 + 1,608 \times [H_d \times (1 - 1 / DF) + H_a \times (1 / DF)]}$$

$$H_d = \frac{6,22 \times R_d \times p_d}{p_B - p_d \times R_d \times 10^{-2}}$$

For the intake air (if different from the dilution air):

$$k_{W,a} = 1 - k_{W2}$$

$$k_{W2} = \frac{1,608 \times H_a}{1000 + (1,608 \times H_a)}$$

$$H_a = \frac{6,22 \times R_a \times p_a}{p_B - p_a \times R_a \times 10^{-2}}$$

where:

H_a	:	absolute humidity of the intake air (g water per kg dry air)
H_d	:	absolute humidity of the dilution air (g water per kg dry air)
R_d	:	relative humidity of the dilution air (%)
R_a	:	relative humidity of the intake air (%)
p_d	:	saturation vapour pressure of the dilution air (kPa)
p_a	:	saturation vapour pressure of the intake air (kPa)
p_B	:	total barometric pressure (kPa).

NOTE: H_a and H_d may be derived from relative humidity measurement, as described above, or from dewpoint measurement, vapour pressure measurement or dry/wet bulb measurement using the generally accepted formulae.

1.3.3. Humidity correction for NOx

Status: EU Directives are being published on this site to aid cross referencing from UK legislation. After IP completion day (31 December 2020 11pm) no further amendments will be applied to this version.

As the NO_x emission depends on ambient air conditions, the NO_x concentration shall be corrected for ambient air temperature and humidity by the factors K_H given in the following formula:

$$k_H = \frac{1}{1 - 0,0182 \times (H_a - 10,71) + 0,0045 \times (T_a - 298)}$$

where:

T_a : temperatures of the air in (K)
 H_a : humidity of the intake air (g water per kg dry air):

$$H_a = \frac{6,220 \times R_a \times p_a}{p_B - p_a \times R_a \times 10^3}$$

where:

R_a : relative humidity of the intake air (%)
 p_a : saturation vapour pressure of the intake air (kPa)
 p_B : total barometric pressure (kPa).

NOTE: H_a may be derived from relative humidity measurement, as described above, or from dewpoint measurement, vapour pressure measurement or dry/wet bulb measurement using the generally accepted formulae.

1.3.4. Calculation of emission mass flow rates

The emission mass flow rates for each mode shall be calculated as follows:

(a) For the raw exhaust gas⁽¹⁷⁾:

$$Gas_{mass} = u \times conc \times G_{EXHW}$$

(b) For the dilute exhaust gas⁽¹⁷⁾:

$$Gas_{mass} = u \times conc_c \times G_{TOTW}$$

where:

$conc_c$ is the background corrected concentration

$$conc_c = conc - conc_d \times (1 - (1 / DF))$$

$$DF = 13,4 / (conc_{CO_2} + (conc_{CO} + conc_{HC}) \times 10^{-4})$$

or:

$$DF = 13,4 / conc_{CO_2}$$

The coefficients u - wet shall be used according to Table 4:

TABLE 4. VALUES OF THE COEFFICIENTS U - WET FOR VARIOUS EXHAUST COMPONENTS

Gas	u	conc
NO _x	0,001587	ppm
CO	0,000966	ppm
HC	0,000479	ppm

Status: EU Directives are being published on this site to aid cross referencing from UK legislation. After IP completion day (31 December 2020 11pm) no further amendments will be applied to this version.

CO ₂	15,19	percent
-----------------	-------	---------

The density of HC is based upon an average carbon to hydrogen ratio of 1:1,85.

1.3.5. Calculation of the specific emissions

The specific emission (g/kWh) shall be calculated for all individual components in the following way:

$$\text{Individual gas} = \frac{\sum_{i=1}^n \text{Gas}_{mass,i} \times \text{WF}_i}{\sum_{i=1}^n P_i \times \text{WF}_i}$$

where $P_i = P_{m,i} + P_{AE,i}$.

The weighting factors and the number of modes (n) used in the above calculation are according to Annex III, section 3.7.1.

1.4. Calculation of the particulate emission

The particulate emission shall be calculated in the following way:

1.4.1. Humidity correction factor for particulates

As the particulate emission of diesel engines depends on ambient air conditions, the particulate mass flow rate shall be corrected for ambient air humidity with the factor K_p given in the following formula:

$$K_p = 1 / (1 + 0,0133 \times (H_a - 10,71))$$

where:

H_a : humidity of the intake air, gram of water per kg dry air

$$H_a = \frac{0,220 \times R_a \times p_a}{p_B - p_a \times R_a \times 10^{-3}}$$

where:

R_a : relative humidity of the intake air (%)
 p_a : saturation vapour pressure of the intake air (kPa)
 p_B : total barometric pressure (kPa)

NOTE: H_a may be derived from relative humidity measurement, as described above, or from dewpoint measurement, vapour pressure measurement or dry/wet bulb measurement using the generally accepted formulae

1.4.2. Partial flow dilution system

The final reported test results of the particulate emission shall be derived through the following steps. Since various types of dilution rate control may be used, different calculation methods for equivalent diluted exhaust gas mass flow rate G_{EDF} apply. All calculations shall be based upon the average values of the individual modes (i) during the sampling period.

1.4.2.1. Isokinetic systems

$$G_{EDFW,j} = G_{EXHW,j} \times q_i$$

Status: EU Directives are being published on this site to aid cross referencing from UK legislation. After IP completion day (31 December 2020 11pm) no further amendments will be applied to this version.

$$q_i = \frac{G_{DILW,i} + (G_{EXHW,i} \times r)}{(G_{EXHW,i} \times r)}$$

where r corresponds to the ratio of the cross sectional areas of the isokinetic probe A_p and exhaust pipe A_T :

$$r = \frac{A_p}{A_T}$$

1.4.2.2. Systems with measurement of CO₂ or NO_x concentration

$$G_{EDFW,i} = G_{EXHW,i} \times q_i$$

$$q_i = \frac{Conc_{E,i} - Conc_{A,i}}{Conc_{D,i} - Conc_{A,i}}$$

where:

Conc _E	=	wet concentration of the tracer gas in raw exhaust
Conc _D	=	wet concentration of the tracer gas in the diluted exhaust
Conc _A	=	wet concentration of the tracer gas in the dilution air

Concentrations measured on a dry basis shall be converted to a wet basis according to section 1.3.2..

1.4.2.3. Systems with CO₂ measurement and carbon balance method

$$G_{EDFW,i} = \frac{206,6 \times G_{FUEL,i}}{CO_{2D,i} - CO_{2A,i}}$$

where:

CO _{2D}	=	CO ₂ concentration of the diluted exhaust
CO _{2A}	=	CO ₂ concentration of the dilution air

(concentrations in volume % on wet basis)

This equation is based upon the carbon balance assumption (carbon atoms supplied to the engine are emitted as CO₂) and derived through the following steps:

$$G_{EDFW,i} = G_{EXHW,i} \times q_i$$

and:

$$q_i = \frac{206,6 \times G_{FUEL,i}}{G_{EXHW,i} \times (CO_{2D,i} - CO_{2A,i})}$$

1.4.2.4. Systems with flow measurement

$$G_{EDFW,i} = G_{EXHW,i} \times q_i$$

$$q_i = \frac{G_{TOTW,i}}{(G_{TOTW,i} - G_{DILW,i})}$$

1.4.3. Full flow dilution system

The final reported test results of the particulate emission shall be derived through the following steps.

All calculations shall be based upon the average values of the individual modes (i) during the sampling period.

$$G_{EDFW,i} = G_{TOTW,i}$$

1.4.4. Calculation of the particulate mass flow rate

The particulate mass flow rate shall be calculated as follows:

For the single filter method:

$$PT_{mass} = \frac{M_f}{M_{SAM}} \times \frac{(G_{EDFW})_{aver}}{1000}$$

where:

$(G_{EDFW})_{aver}$ over the test cycle shall be determined by summation of the average values of the individual modes during the sampling period:

$$(G_{EDFW})_{aver} = \frac{\sum_{i=1}^n G_{EDFW,i} \times WF_i}{\sum_{i=1}^n M_{SAM,i}}$$

where $i = 1, \dots, n$

For the multiple filter method:

$$PT_{mass} = \frac{M_{f,i}}{M_{SAM,i}} \times \frac{(G_{EDFW,i})_{aver}}{1000}$$

where $i = 1, \dots, n$

The particulate mass flow rate may be background corrected as follows:

For single filter method:

$$PT_{mass} = \left[\frac{M_f}{M_{SAM}} - \left(\frac{M_d}{M_{DIL}} \times \left(\sum_{i=1}^{i=n} \left(1 - \frac{1}{DF_i} \right) \times WF_i \right) \right) \right] \times \frac{(G_{EDFW})_{aver}}{1000}$$

If more than one measurement is made, (M_d/M_{DIL}) shall be replaced with $(M_d/M_{DIL})_{aver}$

$$DF = 13,4 / (\text{concCO}_2 + (\text{concCO} + \text{concHC}) \times 10^{-4})$$

or:

$$DF = 13,4 / \text{concCO}_2$$

For multiple filter method:

$$PT_{mass,i} = \left[\frac{M_{f,i}}{M_{SAM,i}} - \left(\frac{M_d}{M_{DIL}} \times \left(1 - \frac{1}{DF_i} \right) \right) \right] \times \left[\frac{G_{EDFW,i}}{1000} \right]$$

If more than one measurement is made, (M_d/M_{DIL}) shall be replaced with $(M_d/M_{DIL})_{aver}$

$$DF = 13,4 / (\text{concCO}_2 + (\text{concCO} + \text{concHC}) \times 10^{-4})$$

or:

$$DF = 13,4 / \text{concCO}_2$$

1.4.5. Calculation of the specific emissions

The specific emission of particulates PT (g/kWh) shall be calculated in the following way⁽¹⁸⁾:

For the single filter method:

$$PT = \frac{PT_{mass}}{\sum_{i=1}^n P_i \times WF_i}$$

Status: EU Directives are being published on this site to aid cross referencing from UK legislation. After IP completion day (31 December 2020 11pm) no further amendments will be applied to this version.

For the multiple filter method:

$$PT = \frac{\sum_{i=1}^n PT_{\text{mode},i} \times WF_i}{\sum_{i=1}^n P_i \times WF_i}$$

1.4.6. Effective weighting factor

For the single filter method, the effective weighting factor $WF_{E,i}$ for each mode shall be calculated in the following way:

$$WF_{E,i} = \frac{M_{SAM,i} \times (GEDFW)_{\text{test}}}{M_{SAM} \times (GEDFW)_i}$$

where $i = 1, \dots, n$.

The value of the effective weighting factors shall be within $\pm 0,005$ (absolute value) of the weighting factors listed in Annex III, section 3.7.1.

(f) The following section shall be inserted:

2. DATA EVALUATION AND CALCULATIONS (NRTC TEST)

The two following measurement principles that can be used for the evaluation of pollutant emissions over the NRTC cycle are described in this section:

- the gaseous components are measured in the raw exhaust gas on a real time basis, and the particulates are determined using a partial flow dilution system;
- the gaseous components and the particulates are determined using a full flow dilution system (CVS system).

2.1. Calculation of gaseous emissions in the raw exhaust gas and of the particulate emissions with a partial flow dilution system

2.1.1. Introduction

The instantaneous concentration signals of the gaseous components are used for the calculation of the mass emissions by multiplication with the instantaneous exhaust mass flow rate. The exhaust mass flow rate may be measured directly, or calculated using the methods described in Annex III, Appendix 1, section 2.2.3 (intake air and fuel flow measurement, tracer method, intake air and air/fuel ratio measurement). Special attention shall be paid to the response times of the different instruments. These differences shall be accounted for by time aligning the signals.

For particulates, the exhaust mass flow rate signals are used for controlling the partial flow dilution system to take a sample proportional to the exhaust mass flow rate. The quality of proportionality is checked by applying a regression analysis between sample and exhaust flow as described in Annex III, Appendix 1, section 2.4.

2.1.2. Determination of the gaseous components

2.1.2.1. Calculation of mass emission

The mass of the pollutants M_{gas} (g/test) shall be determined by calculating the instantaneous mass emissions from the raw concentrations of the pollutants, the u values from Table 4 (see also Section 1.3.4) and the exhaust mass flow,

aligned for the transformation time and integrating the instantaneous values over the cycle. Preferably, the concentrations should be measured on a wet basis. If measured on a dry basis, the dry/wet correction as described here below shall be applied to the instantaneous concentration values before any further calculation is done.

TABLE 4. VALUES OF THE COEFFICIENTS U - WET-FOR VARIOUS EXHAUST COMPONENTS

Gas	u	conc
NO _x	0,001587	ppm
CO	0,000966	ppm
HC	0,000479	ppm
CO ₂	15,19	percent

The density of HC is based upon an average carbon to hydrogen ratio of 1:1,85.

The following formula shall be applied:

$$M_{gas} = \sum_{i=1}^{i=n} u \times conc_i \times G_{EXHW,i} \times \frac{1}{f} \text{ (in/g/test)}$$

where

u	=	ratio between density of exhaust component and density of exhaust gas
$conc_i$	=	instantaneous concentration of the respective component in the raw exhaust gas (ppm)
$G_{EXHW,i}$	=	instantaneous exhaust mass flow (kg/s)
f	=	data sampling rate (Hz)
n	=	number of measurements

For the calculation of NO_x, the humidity correction factor k_H , as described here below, shall be used.

The instantaneously measured concentration shall be converted to a wet basis as described here below, if no1 already measured on a wet basis

2.1.2.2. Dry/wet correction

If the instantaneously measured concentration is measured on a dry basis, it shall be converted to a wet basis according to the following formulae:

$$conc_{wet} = k_w \times conc_{dry}$$

where

$$K_{w,r,1} = \left(\frac{1}{1 + 1,88 \times 0,005 \times (conc_{CO} + conc_{CO_2}) + K_{w2}} \right)$$

with

$$K_{w2} = \frac{1,608 \times H_a}{1000 + (1,608 \times H_a)}$$

Status: EU Directives are being published on this site to aid cross referencing from UK legislation. After IP completion day (31 December 2020 11pm) no further amendments will be applied to this version.

where

$conc_{CO_2}$ = dry CO₂ concentration (%)
 $conc_{CO}$ = dry CO concentration (%)
 H_a = intake air humidity, (g water per kg dry air)

$$H_a = \frac{6,220 \times R_a \times p_a}{p_B - p_a \times R_a \times 10^{-2}}$$

R_a : relative humidity of the intake air (%)
 p_a : saturation vapour pressure of the intake air (kPa)
 p_B : total barometric pressure (kPa)

NOTE: H_a may be derived from relative humidity measurement, as described above, or from dewpoint measurement, vapour pressure measurement or dry/wet bulb measurement using the generally accepted formulae.

2.1.2.3. NO_x correction for humidity and temperature

As the NO_x emission depends on ambient air conditions, the NO_x concentration shall be corrected for humidity and ambient air temperature with the factors given in the following formula:

$$k_H = \frac{1}{1 - 0,0182 \times (H_a - 10,71) + 0,0045 \times (T_a - 298)}$$

with:

T_a = temperature of the intake air, K
 H_a = humidity of the intake air, g water per kg dry air

$$H_a = \frac{6,220 \times R_a \times p_a}{p_B - p_a \times R_a \times 10^{-2}}$$

where:

R_a : relative humidity of the intake air (%)
 p_a : saturation vapour pressure of the intake air (kPa)
 p_B : total barometric pressure (kPa)

NOTE: H_a may be derived from relative humidity measurement, as described above, or from dewpoint measurement, vapour pressure measurement or dry/wet bulb measurement using the generally accepted formulae.

2.1.2.4. Calculation of the specific emissions

The specific emissions (g/kWh) shall be calculated for each individual component in the following way:

$$\text{Individual gas} = M_{gas} / W_{act}$$

where

W_{act} = actual cycle work as determined in Annex III Section 4.6.2 (kWh)

2.1.3. Particulate determination

2.1.3.1. Calculation of mass emission

The mass of particulates M_{PT} (g/test) shall be calculated by either of the following methods:

$$(a) \quad M_{PT} = \frac{M_f}{M_{SAM}} \times \frac{M_{EDFW}}{1000}$$

where

M_f	=	particulate mass sampled over the cycle (mg)
M_{SAM}	=	mass of diluted exhaust gas passing the particulate collection filters (kg)
M_{EDFW}	=	mass of equivalent diluted exhaust gas over the cycle (kg)

The total mass of equivalent diluted exhaust gas mass over the cycle shall be determined as follows:

$$M_{EDFW} = \sum_{i=1}^{i=n} G_{EDFW,i} \times \frac{1}{f}$$

$$G_{EDFW,i} = G_{EXHW,i} \times q_i$$

$$q_i = \frac{G_{TOTW,i}}{(G_{TOTW,i} - G_{DILW,i})}$$

where

$G_{EDFW,i}$	=	instantaneous equivalent diluted exhaust mass flow rate (kg/s)
$G_{EXHW,i}$	=	instantaneous exhaust mass flow rate (kg/s)
q_i	=	instantaneous dilution ratio
$G_{TOTW,i}$	=	instantaneous diluted exhaust mass flow rate through dilution tunnel (kg/s)
$G_{DILW,i}$	=	instantaneous dilution air mass flow rate (kg/s)
f	=	data sampling rate (Hz)
n	=	number of measurements

$$(b) \quad M_{PT} = \frac{M_f}{r_s \times 1000}$$

where

Status: EU Directives are being published on this site to aid cross referencing from UK legislation. After IP completion day (31 December 2020 11pm) no further amendments will be applied to this version.

M_f = particulate mass sampled over the cycle (mg)
 r_s = average sample ratio over the test cycle

where

$$r_s = \frac{M_{SE}}{M_{EXHW}} \times \frac{M_{SAM}}{M_{TOTW}}$$

M_{SE} = sampled exhaust mass over the cycle (kg)
 M_{EXHW} = total exhaust mass flow over the cycle (kg)
 M_{SAM} = mass of diluted exhaust gas passing the particulate collection filters (kg)
 M_{TOTW} = mass of diluted exhaust gas passing the dilution tunnel (kg)

NOTE: In case of the total sampling type system, M_{SAM} and M_{TOTW} are identical.

2.1.3.2. Particulate correction factor for humidity

As the particulate emission of diesel engines depends on ambient air conditions, the particulate concentration shall be corrected for ambient air humidity with the factor K_p given in the following formula.

$$k_p = \frac{1}{[1 + 0,0133 \times (H_a - 10,71)]}$$

where

H_a = humidity of the intake air in g water per kg dry air

$$H_a = \frac{0,220 \times R_a \times p_a}{p_B - p_a \times R_a \times 10^2}$$

R_a : relative humidity of the intake air (%)
 p_a : saturation vapour pressure of the intake air (kPa)
 p_B : total barometric pressure (kPa)

NOTE: H_a may be derived from relative humidity measurement, as described above, or from dewpoint measurement, vapour pressure measurement or dry/wet bulb measurement using the generally accepted formulae.

2.1.3.3. Calculation of the specific emissions

The particulate emission (g/kWh) shall be calculated in the following way:

$$PT = M_{PT} \times K_p / W_{act}$$

where

W_{act} = actual cycle work as determined in Annex III Section 4.6.2(kWh)

2.2. Determination of gaseous and particulate components with a full flow dilution system

For calculation of the emissions in the diluted exhaust gas, it is necessary to know the diluted exhaust gas mass flow rate. The total diluted exhaust gas flow over the cycle M_{TOTW} (kg/test) shall be calculated from the measurement values over the cycle and the corresponding calibration data of the flow measurement device (V_0 for PDP, K_V for CFV, C_d for SSV): the corresponding methods described in section 2.2.1 may be used. If the total sample mass of particulates (M_{SAM}) and gaseous pollutants exceeds 0,5% of the total CVS flow (M_{TOTW}), the CVS flow shall be corrected for M_{SAM} or the particulate sample flow shall be returned to the CVS prior to the flow measuring device.

2.2.1. Determination of the Diluted Exhaust Gas Flow

PDP-CVS system

The calculation of the mass flow over the cycle, if the temperature of the diluted exhaust is kept within $\pm 6K$ over the cycle by using a heat exchanger, is as follows:

$$M_{TOTW} = 1,293 \times V_0 \times N_p \times (p_B - p_1) \times 273 / (101,3 \times T)$$

where

M_{TOTW} = mass of the diluted exhaust gas on wet basis over the cycle
 V_0 = volume of gas pumped per revolution under test conditions (m^3/rev)
 N_p = total revolutions of pump per test
 p_B = atmospheric pressure in the test cell (kPa)
 p_1 = pressure drop below atmospheric at the pump inlet (kPa)
 T = average temperature of the diluted exhaust gas at pump inlet over the cycle (K)

If a system with flow compensation is used (i.e. without heat exchanger), the instantaneous mass emissions shall be calculated and integrated over the cycle. In this case, the instantaneous mass of the diluted exhaust gas shall be calculated as follows:

$$M_{TOTW,i} = 1,293 \times V_0 \times N_{p,i} \times (p_B - p_1) \times 273 / (101,3 \times T)$$

where

$N_{p,i}$ = total revolutions of pump per time interval

CFV-CVS system

Status: EU Directives are being published on this site to aid cross referencing from UK legislation. After IP completion day (31 December 2020 11pm) no further amendments will be applied to this version.

The calculation of the mass flow over the cycle, if the temperature of the diluted exhaust gas is kept within $\pm 11\text{K}$ over the cycle by using a heat exchanger, is as follows:

$$M_{TOTW} = 1,293 \times t \times K_v \times P_A / T^{0,5}$$

where

M_{TOTW}	=	mass of the diluted exhaust gas on wet basis over the cycle
t	=	cycle time (s)
K_v	=	calibration coefficient of the critical flow venturi for standard conditions,
P_A	=	absolute pressure at venturi inlet (kPa)
T	=	absolute temperature at venturi inlet (K)

If a system with flow compensation is used (i.e. without heat exchanger), the instantaneous mass emissions shall be calculated and integrated over the cycle. In this case, the instantaneous mass of the diluted exhaust gas shall be calculated as follows:

$$M_{TOTW,i} = 1,293 \times \Delta t_i \times K_v \times P_A / T^{0,5}$$

where

Δt_i	=	time interval(s)
--------------	---	------------------

SSV-CVS system

The calculation of the mass flow over the cycle is as follows if the temperature of the diluted exhaust is kept within $\pm 11\text{K}$ over the cycle by using a heat exchanger:

$$M_{TOTW} = 1,293 \times Q_{SSV}$$

where

$$Q_{SSV} = A_0 d^2 C_d P_A \sqrt{\left[\frac{1}{T} (r^{1,4286} - r^{1,7143}) \cdot \left(\frac{1}{1 - \beta^4 r^{1,4286}} \right) \right]}$$

A_0	=	collection of constants and units conversions
-------	---	---

= 0,006111 in SI units of

$$\left(\frac{\text{m}^3}{\text{min}} \right) \left(\frac{\text{K}^{1/2}}{\text{kPa}} \right) \left(\frac{1}{\text{mm}^2} \right)$$

d	=	diameter of the SSV throat (m)
C_d	=	discharge coefficient of the SSV
P_A	=	absolute pressure at venturi inlet (kPa)
T	=	temperature at the venturi inlet (K)
r	=	ratio of the SSV throat to inlet absolute, static pressure =

$$1 - \frac{\Delta P}{P_A}$$

β	=	ratio of the SSV throat diameter, d, to the inlet pipe inner diameter =
---------	---	---

$$\frac{d}{D}$$

If a system with flow compensation is used (i.e. without heat exchanger), the instantaneous mass emissions shall be calculated and integrated over the cycle. In this case, the instantaneous mass of the diluted exhaust gas shall be calculated as follows:

$$M_{TOTW} = 1,293 \times Q_{SSV} \times \Delta t_i$$

where

$$Q_{SSV} = A_0 d^2 C_d P_A \sqrt{\left[\frac{1}{T} (r^{1.4286} - r^{1.7143}) \left(\frac{1}{1 - d^4 r^{1.4286}} \right) \right]}$$

$$\Delta t_i = \text{time interval (s)}$$

The real time calculation shall be initialized with either a reasonable value for C_d , such as 0.98, or a reasonable value of Q_{SSV} . If the calculation is initialized with Q_{SSV} , the initial value of Q_{SSV} shall be used to evaluate Re .

During all emissions tests, the Reynolds number at the SSV throat must be in the range of Reynolds numbers used to derive the calibration curve developed in Appendix 2 section 3.2.

2.2.2. NOx Correction for Humidity

As the NOx emission depends on ambient air conditions, the NOx concentration shall be corrected for ambient air humidity with the factors given in the following formulae.

$$K_H = \frac{1}{1 - 0,0182 \times (H_a - 10,71) + 0,0045 \times (T_a - 298)}$$

where

$$\begin{aligned} T_a &= \text{temperature of the air (K)} \\ H_a &= \text{humidity of the intake air (g water per kg dry air)} \end{aligned}$$

in which,

$$H_a = \frac{0,220 \times R_a \times p_a}{p_B - p_a + R_a \times 10^{-2}}$$

$$\begin{aligned} R_a &= \text{relative humidity of the intake air (\%)} \\ p_a &= \text{saturation vapour pressure of the intake air (kPa)} \\ p_B &= \text{total barometric pressure (kPa)} \end{aligned}$$

NOTE: H_a may be derived from relative humidity measurement, as described above, or from dewpoint measurement, vapour pressure measurement or dry/wet bulb measurement using the generally accepted formulae.

2.2.3. Calculation of the Emission Mass Flow

2.2.3.1. Systems with Constant Mass Flow

For systems with heat exchanger, the mass of the pollutants M_{GAS} (g/test) shall be determined from the following equation:

$$M_{GAS} = u \times \text{conc} \times M_{TOTW}$$

where

Status: EU Directives are being published on this site to aid cross referencing from UK legislation. After IP completion day (31 December 2020 11pm) no further amendments will be applied to this version.

u	=	ratio between density of the exhaust component and density of diluted exhaust gas, as reported in Table 4, point 2.1.2.1
conc	=	average background corrected concentrations over the cycle from integration (mandatory for NO _x and HC) or bag measurement (ppm)
M _{TOTW}	=	total mass of diluted exhaust gas over the cycle as determined in section 2.2.1 (kg)

As the NO_x emission depends on ambient air conditions, the NO_x concentration shall be corrected for ambient air humidity with the factor k_H , as described in section 2.2.2.

Concentrations measured on a dry basis shall be converted to a wet basis in accordance with section 1.3.2

2.2.3.1.1. Determination of the Background Corrected Concentrations

The average background concentration of the gaseous pollutants in the dilution air shall be subtracted from measured concentrations to get the net concentrations of the pollutants. The average values of the background concentrations can be determined by the sample bag method or by continuous measurement with integration. The following formula shall be used.

$$\text{conc} = \text{conc}_e - \text{conc}_d \times (1 - (1/\text{DF}))$$

where,

conc	=	concentration of the respective pollutant in the diluted exhaust gas, corrected by the amount of the respective pollutant contained in the dilution air (ppm)
conc _e	=	concentration of the respective pollutant measured in the diluted exhaust gas (ppm)
conc _d	=	concentration of the respective pollutant measured in the dilution air (ppm)
DF	=	dilution factor

The dilution factor shall be calculated as follows:

$$\text{DF} = \frac{13,4}{\text{conc}_{e, \text{CO}_2} + (\text{conc}_{e, \text{HC}} + \text{conc}_{e, \text{CO}}) \times 10^{-4}}$$

2.2.3.2. Systems with Flow Compensation

For systems without heat exchanger, the mass of the pollutants M_{GAS} (g/test) shall be determined by calculating the instantaneous mass emissions and integrating the instantaneous values over the cycle. Also, the background correction shall be applied directly to the instantaneous concentration value. The following formulae shall be applied:

$$M_{GAS} = \sum_{i=1}^n (M_{TOTW,i} \times conc_{e,i} \times u) - (M_{TOTW} \times conc_d \times (1 - 1 / DF) \times u)$$

where

$conc_{e,i}$	=	instantaneous concentration of the respective pollutant measured in the diluted exhaust gas (ppm)
$conc_d$	=	concentration of the respective pollutant measured in the dilution air (ppm)
u	=	ratio between density of the exhaust component and density of diluted exhaust gas, as reported in Table 4, point 2.1.2.1
$M_{TOTW,i}$	=	instantaneous mass of the diluted exhaust gas (section 2.2.1) (kg)
M_{TOTW}	=	total mass of diluted exhaust gas over the cycle (section 2.2.1) (kg)
DF	=	dilution factor as determined in point 2.2.3.1.1.

As the NO_x emission depends on ambient air conditions, the NO_x concentration shall be corrected for ambient air humidity with the factor k_H , as described in section 2.2.2.

2.2.4. Calculation of the Specific Emissions

The specific emissions (g/kWh) shall be calculated for each individual component in the following way:

$$\text{Individual gas} = M_{gas} / W_{act}$$

where

W_{act}	=	actual cycle work as determined in Annex III Section 4.6.2 (kWh)
-----------	---	--

2.2.5. Calculation of the particulate emission

2.2.5.1. Calculation of the Mass Flow

The particulate mass M_{PT} (g/test) shall be calculated as follows:

$$M_{PT} = \frac{M_f}{M_{SAM}} \times \frac{M_{TOTW}}{1000}$$

M_f	=	particulate mass sampled over the cycle (mg)
M_{TOTW}	=	total mass of diluted exhaust gas over the cycle as determined in section 2.2.1 (kg)
M_{SAM}	=	mass of diluted exhaust gas taken from the dilution tunnel for collecting particulates (kg)

and,

M_f	=	$M_{f,p} + M_{f,b}$, if weighed separately (mg)
-------	---	--

Status: EU Directives are being published on this site to aid cross referencing from UK legislation. After IP completion day (31 December 2020 11pm) no further amendments will be applied to this version.

$M_{f,p}$ = particulate mass collected on the primary filter (mg)
 $M_{f,b}$ = particulate mass collected on the back-up filter (mg)

If a double dilution system is used, the mass of the secondary dilution air shall be subtracted from the total mass of the double diluted exhaust gas sampled through the particulate filters.

$$M_{SAM} = M_{TOT} - M_{SEC}$$

where

M_{TOT} = mass of double diluted exhaust gas through particulate filter (kg)
 M_{SEC} = mass of secondary dilution air (kg)

If the particulate background level of the dilution air is determined in accordance with Annex III, section 4.4.4, the particulate mass may be background corrected. In this case, the particulate mass (g/test) shall be calculated as follows:

$$M_{PT} = \left[\frac{M_f}{M_{SAM}} - \left(\frac{M_d}{M_{DIL}} \times \left(1 - \frac{1}{DF} \right) \right) \right] \times \frac{M_{TOTW}}{1000}$$

where

M_f , M_{SAM} , M_{TOTW} , M_{DIL} = see above
 M_d = mass of the collected background particulates of the primary dilution air (mg)
 DF = dilution factor as determined in section 2.2.3.1.1

2.2.5.2. Particulate correction factor for humidity

As the particulate emission of diesel engines depends on ambient air conditions, the particulate concentration shall be corrected for ambient air humidity with the factor K_p given in the following formula.

$$k_p = \frac{1}{[1 + 0,0133 \times (H_a - 10,71)]}$$

where

H_a = humidity of the intake air in g water per kg dry air

$$H_a = \frac{0,220 \times R_a \times p_a}{p_B - p_a \times R_a \times 10^{-3}}$$

where:

R_a : relative humidity of the intake air (%)
 p_a : saturation vapour pressure of the intake air (kPa)
 p_B : total barometric pressure (kPa)

Status: EU Directives are being published on this site to aid cross referencing from UK legislation. After IP completion day (31 December 2020 11pm) no further amendments will be applied to this version.

NOTE: H_a may be derived from relative humidity measurement, as described above, or from dewpoint measurement, vapour pressure measurement or dry/wet bulb measurement using the generally accepted formulae.

2.2.5.3. Calculation of the Specific Emission

The particulate emission (g/kWh) shall be calculated in the following way:

$$PT = M_{PT} \times K_p / W_{act}$$

where

W_{act} = actual cycle work, as determined in Annex III Section 4.6.2 (kWh)

9) The following Appendices shall be added:

"

APPENDIX 4

NRTC ENGINE DYNAMOMETER SCHEDULE

Time(s)	Norm. Speed(%)	Norm. Torque(%)
1	0	0
2	0	0
3	0	0
4	0	0
5	0	0
6	0	0
7	0	0
8	0	0
9	0	0
10	0	0
11	0	0
12	0	0
13	0	0
14	0	0
15	0	0
16	0	0
17	0	0
18	0	0
19	0	0

Status: EU Directives are being published on this site to aid cross referencing from UK legislation. After IP completion day (31 December 2020 11pm) no further amendments will be applied to this version.

20	0	0
21	0	0
22	0	0
23	0	0
24	1	3
25	1	3
26	1	3
27	1	3
28	1	3
29	1	3
30	1	6
31	1	6
32	2	1
33	4	13
34	7	18
35	9	21
36	17	20
37	33	42
38	57	46
39	44	33
40	31	0
41	22	27
42	33	43
43	80	49
44	105	47
45	98	70
46	104	36
47	104	65
48	96	71
49	101	62
50	102	51
51	102	50
52	102	46
53	102	41

Status: EU Directives are being published on this site to aid cross referencing from UK legislation. After IP completion day (31 December 2020 11pm) no further amendments will be applied to this version.

54	102	31
55	89	2
56	82	0
57	47	1
58	23	1
59	1	3
60	1	8
61	1	3
62	1	5
63	1	6
64	1	4
65	1	4
66	0	6
67	1	4
68	9	21
69	25	56
70	64	26
71	60	31
72	63	20
73	62	24
74	64	8
75	58	44
76	65	10
77	65	12
78	68	23
79	69	30
80	71	30
81	74	15
82	71	23
83	73	20
84	73	21
85	73	19
86	70	33
87	70	34

Status: EU Directives are being published on this site to aid cross referencing from UK legislation. After IP completion day (31 December 2020 11pm) no further amendments will be applied to this version.

88	65	47
89	66	47
90	64	53
91	65	45
92	66	38
93	67	49
94	69	39
95	69	39
96	66	42
97	71	29
98	75	29
99	72	23
100	74	22
101	75	24
102	73	30
103	74	24
104	77	6
105	76	12
106	74	39
107	72	30
108	75	22
109	78	64
110	102	34
111	103	28
112	103	28
113	103	19
114	103	32
115	104	25
116	103	38
117	103	39
118	103	34
119	102	44
120	103	38
121	102	43

Status: EU Directives are being published on this site to aid cross referencing from UK legislation. After IP completion day (31 December 2020 11pm) no further amendments will be applied to this version.

122	103	34
123	102	41
124	103	44
125	103	37
126	103	27
127	104	13
128	104	30
129	104	19
130	103	28
131	104	40
132	104	32
133	101	63
134	102	54
135	102	52
136	102	51
137	103	40
138	104	34
139	102	36
140	104	44
141	103	44
142	104	33
143	102	27
144	103	26
145	79	53
146	51	37
147	24	23
148	13	33
149	19	55
150	45	30
151	34	7
152	14	4
153	8	16
154	15	6
155	39	47

Status: EU Directives are being published on this site to aid cross referencing from UK legislation. After IP completion day (31 December 2020 11pm) no further amendments will be applied to this version.

156	39	4
157	35	26
158	27	38
159	43	40
160	14	23
161	10	10
162	15	33
163	35	72
164	60	39
165	55	31
166	47	30
167	16	7
168	0	6
169	0	8
170	0	8
171	0	2
172	2	17
173	10	28
174	28	31
175	33	30
176	36	0
177	19	10
178	1	18
179	0	16
180	1	3
181	1	4
182	1	5
183	1	6
184	1	5
185	1	3
186	1	4
187	1	4
188	1	6
189	8	18

Status: EU Directives are being published on this site to aid cross referencing from UK legislation. After IP completion day (31 December 2020 11pm) no further amendments will be applied to this version.

190	20	51
191	49	19
192	41	13
193	31	16
194	28	21
195	21	17
196	31	21
197	21	8
198	0	14
199	0	12
200	3	8
201	3	22
202	12	20
203	14	20
204	16	17
205	20	18
206	27	34
207	32	33
208	41	31
209	43	31
210	37	33
211	26	18
212	18	29
213	14	51
214	13	11
215	12	9
216	15	33
217	20	25
218	25	17
219	31	29
220	36	66
221	66	40
222	50	13
223	16	24

Status: EU Directives are being published on this site to aid cross referencing from UK legislation. After IP completion day (31 December 2020 11pm) no further amendments will be applied to this version.

224	26	50
225	64	23
226	81	20
227	83	11
228	79	23
229	76	31
230	68	24
231	59	33
232	59	3
233	25	7
234	21	10
235	20	19
236	4	10
237	5	7
238	4	5
239	4	6
240	4	6
241	4	5
242	7	5
243	16	28
244	28	25
245	52	53
246	50	8
247	26	40
248	48	29
249	54	39
250	60	42
251	48	18
252	54	51
253	88	90
254	103	84
255	103	85
256	102	84
257	58	66

Status: EU Directives are being published on this site to aid cross referencing from UK legislation. After IP completion day (31 December 2020 11pm) no further amendments will be applied to this version.

258	64	97
259	56	80
260	51	67
261	52	96
262	63	62
263	71	6
264	33	16
265	47	45
266	43	56
267	42	27
268	42	64
269	75	74
270	68	96
271	86	61
272	66	0
273	37	0
274	45	37
275	68	96
276	80	97
277	92	96
278	90	97
279	82	96
280	94	81
281	90	85
282	96	65
283	70	96
284	55	95
285	70	96
286	79	96
287	81	71
288	71	60
289	92	65
290	82	63
291	61	47

Status: EU Directives are being published on this site to aid cross referencing from UK legislation. After IP completion day (31 December 2020 11pm) no further amendments will be applied to this version.

292	52	37
293	24	0
294	20	7
295	39	48
296	39	54
297	63	58
298	53	31
299	51	24
300	48	40
301	39	0
302	35	18
303	36	16
304	29	17
305	28	21
306	31	15
307	31	10
308	43	19
309	49	63
310	78	61
311	78	46
312	66	65
313	78	97
314	84	63
315	57	26
316	36	22
317	20	34
318	19	8
319	9	10
320	5	5
321	7	11
322	15	15
323	12	9
324	13	27
325	15	28

Status: EU Directives are being published on this site to aid cross referencing from UK legislation. After IP completion day (31 December 2020 11pm) no further amendments will be applied to this version.

326	16	28
327	16	31
328	15	20
329	17	0
330	20	34
331	21	25
332	20	0
333	23	25
334	30	58
335	63	96
336	83	60
337	61	0
338	26	0
339	29	44
340	68	97
341	80	97
342	88	97
343	99	88
344	102	86
345	100	82
346	74	79
347	57	79
348	76	97
349	84	97
350	86	97
351	81	98
352	83	83
353	65	96
354	93	72
355	63	60
356	72	49
357	56	27
358	29	0
359	18	13

Status: EU Directives are being published on this site to aid cross referencing from UK legislation. After IP completion day (31 December 2020 11pm) no further amendments will be applied to this version.

360	25	11
361	28	24
362	34	53
363	65	83
364	80	44
365	77	46
366	76	50
367	45	52
368	61	98
369	61	69
370	63	49
371	32	0
372	10	8
373	17	7
374	16	13
375	11	6
376	9	5
377	9	12
378	12	46
379	15	30
380	26	28
381	13	9
382	16	21
383	24	4
384	36	43
385	65	85
386	78	66
387	63	39
388	32	34
389	46	55
390	47	42
391	42	39
392	27	0
393	14	5

Status: EU Directives are being published on this site to aid cross referencing from UK legislation. After IP completion day (31 December 2020 11pm) no further amendments will be applied to this version.

394	14	14
395	24	54
396	60	90
397	53	66
398	70	48
399	77	93
400	79	67
401	46	65
402	69	98
403	80	97
404	74	97
405	75	98
406	56	61
407	42	0
408	36	32
409	34	43
410	68	83
411	102	48
412	62	0
413	41	39
414	71	86
415	91	52
416	89	55
417	89	56
418	88	58
419	78	69
420	98	39
421	64	61
422	90	34
423	88	38
424	97	62
425	100	53
426	81	58
427	74	51

Status: EU Directives are being published on this site to aid cross referencing from UK legislation. After IP completion day (31 December 2020 11pm) no further amendments will be applied to this version.

428	76	57
429	76	72
430	85	72
431	84	60
432	83	72
433	83	72
434	86	72
435	89	72
436	86	72
437	87	72
438	88	72
439	88	71
440	87	72
441	85	71
442	88	72
443	88	72
444	84	72
445	83	73
446	77	73
447	74	73
448	76	72
449	46	77
450	78	62
451	79	35
452	82	38
453	81	41
454	79	37
455	78	35
456	78	38
457	78	46
458	75	49
459	73	
460	79	58
461	79	71

Status: EU Directives are being published on this site to aid cross referencing from UK legislation. After IP completion day (31 December 2020 11pm) no further amendments will be applied to this version.

462	83	44
463	53	48
464	40	48
465	51	75
466	75	72
467	89	67
468	93	60
469	89	73
470	86	73
471	81	73
472	78	73
473	78	73
474	76	73
475	79	73
476	82	73
477	86	73
478	88	72
479	92	71
480	97	54
481	73	43
482	36	64
483	63	31
484	78	1
485	69	27
486	67	28
487	72	9
488	71	9
489	78	36
490	81	56
491	75	53
492	60	45
493	50	37
494	66	41
495	51	61

Status: EU Directives are being published on this site to aid cross referencing from UK legislation. After IP completion day (31 December 2020 11pm) no further amendments will be applied to this version.

496	68	47
497	29	42
498	24	73
499	64	71
500	90	71
501	100	61
502	94	73
503	84	73
504	79	73
505	75	72
506	78	73
507	80	73
508	81	73
509	81	73
510	83	73
511	85	73
512	84	73
513	85	73
514	86	73
515	85	73
516	85	73
517	85	72
518	85	73
519	83	73
520	79	73
521	78	73
522	81	73
523	82	72
524	94	56
525	66	48
526	35	71
527	51	44
528	60	23
529	64	10

Status: EU Directives are being published on this site to aid cross referencing from UK legislation. After IP completion day (31 December 2020 11pm) no further amendments will be applied to this version.

530	63	14
531	70	37
532	76	45
533	78	18
534	76	51
535	75	33
536	81	17
537	76	45
538	76	30
539	80	14
540	71	18
541	71	14
542	71	11
543	65	2
544	31	26
545	24	72
546	64	70
547	77	62
548	80	68
549	83	53
550	83	50
551	83	50
552	85	43
553	86	45
554	89	35
555	82	61
556	87	50
557	85	55
558	89	49
559	87	70
560	91	39
561	72	3
562	43	25
563	30	60

Status: EU Directives are being published on this site to aid cross referencing from UK legislation. After IP completion day (31 December 2020 11pm) no further amendments will be applied to this version.

564	40	45
565	37	32
566	37	32
567	43	70
568	70	54
569	77	47
570	79	66
571	85	53
572	83	57
573	86	52
574	85	51
575	70	39
576	50	5
577	38	36
578	30	71
579	75	53
580	84	40
581	85	42
582	86	49
583	86	57
584	89	68
585	99	61
586	77	29
587	81	72
588	89	69
589	49	56
590	79	70
591	104	59
592	103	54
593	102	56
594	102	56
595	103	61
596	102	64
597	103	60

Status: EU Directives are being published on this site to aid cross referencing from UK legislation. After IP completion day (31 December 2020 11pm) no further amendments will be applied to this version.

598	93	72
599	86	73
600	76	73
601	59	49
602	46	22
603	40	65
604	72	31
605	72	27
606	67	44
607	68	37
608	67	42
609	68	50
610	77	43
611	58	4
612	22	37
613	57	69
614	68	38
615	73	2
616	40	14
617	42	38
618	64	69
619	64	74
620	67	73
621	65	73
622	68	73
623	65	49
624	81	0
625	37	25
626	24	69
627	68	71
628	70	71
629	76	70
630	71	72
631	73	69

Status: EU Directives are being published on this site to aid cross referencing from UK legislation. After IP completion day (31 December 2020 11pm) no further amendments will be applied to this version.

632	76	70
633	77	72
634	77	72
635	77	72
636	77	70
637	76	71
638	76	71
639	77	71
640	77	71
641	78	70
642	77	70
643	77	71
644	79	72
645	78	70
646	80	70
647	82	71
648	84	71
649	83	71
650	83	73
651	81	70
652	80	71
653	78	71
654	76	70
655	76	70
656	76	71
657	79	71
658	78	71
659	81	70
660	83	72
661	84	71
662	86	71
663	87	71
664	92	72
665	91	72

Status: EU Directives are being published on this site to aid cross referencing from UK legislation. After IP completion day (31 December 2020 11pm) no further amendments will be applied to this version.

666	90	71
667	90	71
668	91	71
669	90	70
670	90	72
671	91	71
672	90	71
673	90	71
674	92	72
675	93	69
676	90	70
677	93	72
678	91	70
679	89	71
680	91	71
681	90	71
682	90	71
683	92	71
684	91	71
685	93	71
686	93	68
687	98	68
688	98	67
689	100	69
690	99	68
691	100	71
692	99	68
693	100	69
694	102	72
695	101	69
696	100	69
697	102	71
698	102	71
699	102	69

Status: EU Directives are being published on this site to aid cross referencing from UK legislation. After IP completion day (31 December 2020 11pm) no further amendments will be applied to this version.

700	102	71
701	102	68
702	100	69
703	102	70
704	102	68
705	102	70
706	102	72
707	102	68
708	102	69
709	100	68
710	102	71
711	101	64
712	102	69
713	102	69
714	101	69
715	102	64
716	102	69
717	102	68
718	102	70
719	102	69
720	102	70
721	102	70
722	102	62
723	104	38
724	104	15
725	102	24
726	102	45
727	102	47
728	104	40
729	101	52
730	103	32
731	102	50
732	103	30
733	103	44

Status: EU Directives are being published on this site to aid cross referencing from UK legislation. After IP completion day (31 December 2020 11pm) no further amendments will be applied to this version.

734	102	40
735	103	43
736	103	41
737	102	46
738	103	39
739	102	41
740	103	41
741	102	38
742	103	39
743	102	46
744	104	46
745	103	49
746	102	45
747	103	42
748	103	46
749	103	38
750	102	48
751	103	35
752	102	48
753	103	49
754	102	48
755	102	46
756	103	47
757	102	49
758	102	42
759	102	52
760	102	57
761	102	55
762	102	61
763	102	61
764	102	58
765	103	58
766	102	59
767	102	54

Status: EU Directives are being published on this site to aid cross referencing from UK legislation. After IP completion day (31 December 2020 11pm) no further amendments will be applied to this version.

768	102	63
769	102	61
770	103	55
771	102	60
772	102	72
773	103	56
774	102	55
775	102	67
776	103	56
777	84	42
778	48	7
779	48	6
780	48	6
781	48	7
782	48	6
783	48	7
784	67	21
785	105	59
786	105	96
787	105	74
788	105	66
789	105	62
790	105	66
791	89	41
792	52	5
793	48	5
794	48	7
795	48	5
796	48	6
797	48	4
798	52	6
799	51	5
800	51	6
801	51	6

Status: EU Directives are being published on this site to aid cross referencing from UK legislation. After IP completion day (31 December 2020 11pm) no further amendments will be applied to this version.

802	52	5
803	52	5
804	57	44
805	98	90
806	105	94
807	105	100
808	105	98
809	105	95
810	105	96
811	105	92
812	104	97
813	100	85
814	94	74
815	87	62
816	81	50
817	81	46
818	80	39
819	80	32
820	81	28
821	80	26
822	80	23
823	80	23
824	80	20
825	81	19
826	80	18
827	81	17
828	80	20
829	81	24
830	81	21
831	80	26
832	80	24
833	80	23
834	80	22
835	81	21

Status: EU Directives are being published on this site to aid cross referencing from UK legislation. After IP completion day (31 December 2020 11pm) no further amendments will be applied to this version.

836	81	24
837	81	24
838	81	22
839	81	22
840	81	21
841	81	31
842	81	27
843	80	26
844	80	26
845	81	25
846	80	21
847	81	20
848	83	21
849	83	15
850	83	12
851	83	9
852	83	8
853	83	7
854	83	6
855	83	6
856	83	6
857	83	6
858	83	6
859	76	5
860	49	8
861	51	7
862	51	20
863	78	52
864	80	38
865	81	33
866	83	29
867	83	22
868	83	16
869	83	12

Status: EU Directives are being published on this site to aid cross referencing from UK legislation. After IP completion day (31 December 2020 11pm) no further amendments will be applied to this version.

870	83	9
871	83	8
872	83	7
873	83	6
874	83	6
875	83	6
876	83	6
877	83	6
878	59	4
879	50	5
880	51	5
881	51	5
882	51	5
883	50	5
884	50	5
885	50	5
886	50	5
887	50	5
888	51	5
889	51	5
890	51	5
891	63	50
892	81	34
893	81	25
894	81	29
895	81	23
896	80	24
897	81	24
898	81	28
899	81	27
900	81	22
901	81	19
902	81	17
903	81	17

Status: EU Directives are being published on this site to aid cross referencing from UK legislation. After IP completion day (31 December 2020 11pm) no further amendments will be applied to this version.

904	81	17
905	81	15
906	80	15
907	80	28
908	81	22
909	81	24
910	81	19
911	81	21
912	81	20
913	83	26
914	80	63
915	80	59
916	83	100
917	81	73
918	83	53
919	80	76
920	81	61
921	80	50
922	81	37
923	82	49
924	83	37
925	83	25
926	83	17
927	83	13
928	83	10
929	83	8
930	83	7
931	83	7
932	83	6
933	83	6
934	83	6
935	71	5
936	49	24
937	69	64

Status: EU Directives are being published on this site to aid cross referencing from UK legislation. After IP completion day (31 December 2020 11pm) no further amendments will be applied to this version.

938	81	50
939	81	43
940	81	42
941	81	31
942	81	30
943	81	35
944	81	28
945	81	27
946	80	27
947	81	31
948	81	41
949	81	41
950	81	37
951	81	43
952	81	34
953	81	31
954	81	26
955	81	23
956	81	27
957	81	38
958	81	40
959	81	39
960	81	27
961	81	33
962	80	28
963	81	34
964	83	72
965	81	49
966	81	51
967	80	55
968	81	48
969	81	36
970	81	39
971	81	38

Status: EU Directives are being published on this site to aid cross referencing from UK legislation. After IP completion day (31 December 2020 11pm) no further amendments will be applied to this version.

972	80	41
973	81	30
974	81	23
975	81	19
976	81	25
977	81	29
978	83	47
979	81	90
980	81	75
981	80	60
982	81	48
983	81	41
984	81	30
985	80	24
986	81	20
987	81	21
988	81	29
989	81	29
990	81	27
991	81	23
992	81	25
993	81	26
994	81	22
995	81	20
996	81	17
997	81	23
998	83	65
999	81	54
1000	81	50
1001	81	41
1002	81	35
1003	81	37
1004	81	29
1005	81	28

Status: EU Directives are being published on this site to aid cross referencing from UK legislation. After IP completion day (31 December 2020 11pm) no further amendments will be applied to this version.

1006	81	24
1007	81	19
1008	81	16
1009	80	16
1010	83	23
1011	83	17
1012	83	13
1013	83	27
1014	81	58
1015	81	60
1016	81	46
1017	80	41
1018	80	36
1019	81	26
1020	86	18
1021	82	35
1022	79	53
1023	82	30
1024	83	29
1025	83	32
1026	83	28
1027	76	60
1028	79	51
1029	86	26
1030	82	34
1031	84	25
1032	86	23
1033	85	22
1034	83	26
1035	83	25
1036	83	37
1037	84	14
1038	83	39
1039	76	70

Status: EU Directives are being published on this site to aid cross referencing from UK legislation. After IP completion day (31 December 2020 11pm) no further amendments will be applied to this version.

1040	78	81
1041	75	71
1042	86	47
1043	83	35
1044	81	43
1045	81	41
1046	79	46
1047	80	44
1048	84	20
1049	79	31
1050	87	29
1051	82	49
1052	84	21
1053	82	56
1054	81	30
1055	85	21
1056	86	16
1057	79	52
1058	78	60
1059	74	55
1060	78	84
1061	80	54
1062	80	35
1063	82	24
1064	83	43
1065	79	49
1066	83	50
1067	86	12
1068	64	14
1069	24	14
1070	49	21
1071	77	48
1072	103	11
1073	98	48

Status: EU Directives are being published on this site to aid cross referencing from UK legislation. After IP completion day (31 December 2020 11pm) no further amendments will be applied to this version.

1074	101	34
1075	99	39
1076	103	11
1077	103	19
1078	103	7
1079	103	13
1080	103	10
1081	102	13
1082	101	29
1083	102	25
1084	102	20
1085	96	60
1086	99	38
1087	102	24
1088	100	31
1089	100	28
1090	98	3
1091	102	26
1092	95	64
1093	102	23
1094	102	25
1095	98	42
1096	93	68
1097	101	25
1098	95	64
1099	101	35
1100	94	59
1101	97	37
1102	97	60
1103	93	98
1104	98	53
1105	103	13
1106	103	11
1107	103	11

Status: EU Directives are being published on this site to aid cross referencing from UK legislation. After IP completion day (31 December 2020 11pm) no further amendments will be applied to this version.

1108	103	13
1109	103	10
1110	103	10
1111	103	11
1112	103	10
1113	103	10
1114	102	18
1115	102	31
1116	101	24
1117	102	19
1118	103	10
1119	102	12
1120	99	56
1121	96	59
1122	74	28
1123	66	62
1124	74	29
1125	64	74
1126	69	40
1127	76	2
1128	72	29
1129	66	65
1130	54	69
1131	69	56
1132	69	40
1133	73	54
1134	63	92
1135	61	67
1136	72	42
1137	78	2
1138	76	34
1139	67	80
1140	70	67
1141	53	70

Status: EU Directives are being published on this site to aid cross referencing from UK legislation. After IP completion day (31 December 2020 11pm) no further amendments will be applied to this version.

1142	72	65
1143	60	57
1144	74	29
1145	69	31
1146	76	1
1147	74	22
1148	72	52
1149	62	96
1150	54	72
1151	72	28
1152	72	35
1153	64	68
1154	74	27
1155	76	14
1156	69	38
1157	66	59
1158	64	99
1159	51	86
1160	70	53
1161	72	36
1162	71	47
1163	70	42
1164	67	34
1165	74	2
1166	75	21
1167	74	15
1168	75	13
1169	76	10
1170	75	13
1171	75	10
1172	75	7
1173	75	13
1174	76	8
1175	76	7

Status: EU Directives are being published on this site to aid cross referencing from UK legislation. After IP completion day (31 December 2020 11pm) no further amendments will be applied to this version.

1176	67	45
1177	75	13
1178	75	12
1179	73	21
1180	68	46
1181	74	8
1182	76	11
1183	76	14
1184	74	11
1185	74	18
1186	73	22
1187	74	20
1188	74	19
1189	70	22
1190	71	23
1191	73	19
1192	73	19
1193	72	20
1194	64	60
1195	70	39
1196	66	56
1197	68	64
1198	30	68
1199	70	38
1200	66	47
1201	76	14
1202	74	18
1203	69	46
1204	68	62
1205	68	62
1206	68	62
1207	68	62
1208	68	62
1209	68	62

Status: EU Directives are being published on this site to aid cross referencing from UK legislation. After IP completion day (31 December 2020 11pm) no further amendments will be applied to this version.

1210	54	50
1211	41	37
1212	27	25
1213	14	12
1214	0	0
1215	0	0
1216	0	0
1217	0	0
1218	0	0
1219	0	0
1220	0	0
1221	0	0
1222	0	0
1223	0	0
1224	0	0
1225	0	0
1226	0	0
1227	0	0
1228	0	0
1229	0	0
1230	0	0
1231	0	0
1232	0	0
1233	0	0
1234	0	0
1235	0	0
1236	0	0
1237	0	0
1238	0	0

A graphical display of the NRTC dynamometer schedule is shown below

2.2. Sampling system used for the NRTC test:
 Gaseous emissions ¹:.....
 Particulates ¹:.....

Method ²: single/multiple filter

Status: EU Directives are being published on this site to aid cross referencing from UK legislation. After IP completion day (31 December 2020 11pm) no further amendments will be applied to this version.

APPENDIX 5

DURABILITY REQUIREMENTS

1. EMISSION DURABILITY PERIOD AND DETERIORATION FACTORS.

This appendix shall apply to CI engines Stage IIIA and IIIB and IV only.

1.1. Manufacturers shall determine a Deterioration Factor (DF) value for each regulated pollutant for all Stage IIIA and IIIB engine families. Such DFs shall be used for type approval and production line testing.

1.1.1. Test to establish DF's shall be conducted as follows:

1.1.1.1. The manufacturer shall conduct durability tests to accumulate engine operating hours according to a test schedule that is selected on the basis of good engineering judgement to be representative of in-use engine operation in respect to characterizing emission performance deterioration. The durability test period should typically represent the equivalent of at least one quarter of the Emission Durability Period (EDP).

Service accumulation operating hours may be acquired through running engines on a dynamometer test bed or from actual in-field machine operation. Accelerated durability tests can be applied whereby the service accumulation test schedule is performed at a higher load factor than typically experienced in the field. The acceleration factor relating the number of engine durability test hours to the equivalent number of EDP hours shall be determined by the engine manufacturer based on good engineering judgement.

During the period of the durability test, no emission sensitive components can be serviced or replaced other than to the routine service schedule recommended by the manufacturer.

The test engine, subsystems, or components to be used to determine exhaust emission DF's for an engine family, or for engine families of equivalent emission control system technology, shall be selected by the engine manufacturer on the basis of good engineering judgement. The criteria is that the test engine should represent the emission deterioration characteristic of the engine families that will apply the resulting DF values for certification approval. Engines of different bore and stroke, different configuration, different air management systems, different fuel systems can be considered as equivalent in respect to emissions deterioration characteristics if there is a reasonable technical basis for such determination.

DF values from another manufacturer can be applied if there is a reasonable basis for considering technology equivalence with respect to emissions deterioration, and evidence that the tests have been carried according to the specified requirements.

Emissions testing will be performed according to the procedures defined in this Directive for the test engine after initial run-in but before any service accumulation, and at the completion of the durability. Emission tests can also

be performed at intervals during the service accumulation test period, and applied in determining the deterioration trend.

1.1.1.2. The service accumulation tests or the emissions tests performed to determine deterioration must not be witnessed by the approval authority.

1.1.1.3. Determination of DF values from Durability Tests

An additive DF is defined as the value obtained by subtraction of the emission value determined at the beginning of the EDP, from the emissions value determined to represent the emission performance at the end of the EDP.

A multiplicative DF is defined as the emission level determined for the end of the EDP divided by the emission value recorded at the beginning of the EDP.

Separate DF values shall be established for each of the pollutants covered by the legislation. In the case of establishing a DF value relative to the NO_x+HC standard, for an additive DF, this is determined based on the sum of the pollutants notwithstanding that a negative deterioration for one pollutant may not offset deterioration for the other. For a multiplicative NO_x+HC DF, separate HC and NO_x DF's shall be determined and applied separately when calculating the deteriorated emission levels from an emissions test result before combining the resultant deteriorated NO_x and HC values to establish compliance with the standard.

In cases where the testing is not conducted for the full EDP, the emission values at the end of the EDP is determined by extrapolation of the emission deterioration trend established for the test period, to the full EDP.

When emissions test results have been recorded periodically during the service accumulation durability testing, standard statistical processing techniques based on good practice shall be applied to determine the emission levels at the end of the EDP; statistical significance testing can be applied in the determination of the final emissions values.

If the calculation results in a value of less than 1.00 for a multiplicative DF, or less than 0.00 for an additive DF, then the DF shall be 1.0 or 0.00, respectively.

1.1.1.4. A manufacturer may, with the approval of the type approval authority, use DF values established from results of durability tests conducted to obtain DF values for certification of on-road FID CI engines. This will be allowed if there is technological equivalency between the test on-road engine and the non-road engine families applying the DF values for certification. The DF values derived from on-road engine emission durability test results, must be calculated on the basis of EDP values defined in section 2.

1.1.1.5. In the case where an engine family uses established technology, an analysis based on good engineering practices may be used in lieu of testing to determine a deterioration factor for that engine family subject to approval of the type approval authority.

1.2. DF information in approval applications

Status: EU Directives are being published on this site to aid cross referencing from UK legislation. After IP completion day (31 December 2020 11pm) no further amendments will be applied to this version.

- 1.2.1. Additive DF's shall be specified for each pollutant in an engine family certification application for CI engines not using any aftertreatment device.
- 1.2.2. Multiplicative DF's shall be specified for each pollutant in an engine family certification application for CI engines using an aftertreatment device.
- 1.2.3. The manufacture shall furnish the Type Approval agency on request with information to support the DF values. This would typically include emission test results, service accumulation test schedule, maintenance procedures together with information to support engineering judgements of technological equivalency, if applicable.
2. EMISSION DURABILITY PERIODS FOR STAGE IIIA, IIIB AND IV ENGINES.
 - 2.1. Manufacturers shall use the EDP in Table 1 of this section.

TABLE 1: EDP CATEGORIES FOR CI STAGE IIIA, IIIB AND IV ENGINES (HOURS)

Category (power band)	Useful life (hours)EDP
≤ 37 kW (constant speed engines)	3.000
≤ 37 kW (not constant speed engines)	5.000
> 37 kW	8.000
Engines for the use in inland waterway vessels	10.000
Railcar engines	10.000

3. ANNEX V SHALL BE AMENDED AS FOLLOWS:
 - 1) The heading shall be replaced by the following:

TECHNICAL CHARACTERISTICS OF REFERENCE FUEL PRESCRIBED FOR APPROVAL TESTS AND TO VERIFY CONFORMITY OF PRODUCTION

NON-ROAD MOBILE MACHINERY REFERENCE FUEL FOR CI ENGINES TYPE APPROVED TO MEET STAGE I and II LIMIT VALUES AND FOR ENGINES TO BE USED IN INLAND WATERWAY VESSELS.
 - 2) The following text shall be inserted after the current table on reference fuel for diesel as follows:

NON-ROAD MOBILE MACHINERY REFERENCE FUEL FOR CI ENGINES TYPE APPROVED TO MEET STAGE IIIA LIMIT VALUES.

Parameter	Unit	Limits ^a		Test Method
		Minimum	Maximum	
Cetane number ^b		52	54,0	EN-ISO 5165

Status: EU Directives are being published on this site to aid cross referencing from UK legislation. After IP completion day (31 December 2020 11pm) no further amendments will be applied to this version.

Density at 15°C	kg/m ³	833	837	EN-ISO 3675
Distillation:				
50% point	°C	245		EN-ISO 3405
95% point	°C	345	350	EN-ISO 3405
- Final boiling point	°C		370	EN-ISO 3405
Flash point	°C	55		EN 22719
CFPP	°C		-5	EN 116
Viscosity at 40°C	mm ² /s	2,5	3,5	EN-ISO 3104
Polycyclic aromatic hydrocarbons	% m/m	3,0	6,0	IP 391
Sulphur content ^c	mg/kg		300	ASTM D 5453
Copper corrosion			class 1	EN-ISO 2160
Conradson carbon residue (10% DR)	%m/m		0,2	EN-ISO 10370
Ash content	%m/m		0,01	EN-ISO 6245
Water content	%m/m		0,05	EN-ISO 12937
Neutralisation (strong acid) number	mg KOH/g		0,02	ASTM D 974
Oxidation stability ^d	mg/ml		0,025	EN-ISO 12205

- a** The values quoted in the specifications are "true values". In establishment of their limit values the terms of ISO 4259 "Petroleum products - Determination and application of precision data in relation to methods of test" have been applied and in fixing a minimum value, a minimum difference of 2R above zero has been taken into account; in fixing a maximum and minimum value, the minimum difference is 4R (R = reproducibility).
Notwithstanding this measure, which is necessary for technical reasons, the manufacturer of fuels should nevertheless aim at a zero value where the stipulated maximum value is 2R and at the mean value in the case of quotations of maximum and minimum limits. Should it be necessary to clarify the questions as to whether a fuel meets the requirements of the specifications, the terms of ISO 4259 should be applied.
- b** The range for cetane number is not in accordance with the requirements of a minimum range of 4R. However, in the case of a dispute between fuel supplier and fuel user, the terms of ISO 4259 may be used to resolve such disputes provided replicate measurements, of sufficient number to archive the necessary precision, are made in preference to single determination
- c** The actual sulphur content of the fuel used for the test shall be reported..
- d** Even though oxidation stability is controlled, it is likely that shelf life will be limited. Advice should be sought from the supplier as to storage conditions and life.

Status: EU Directives are being published on this site to aid cross referencing from UK legislation. After IP completion day (31 December 2020 11pm) no further amendments will be applied to this version.

**NON-ROAD MOBILE MACHINERY REFERENCE FUEL FOR CI ENGINES
TYPE APPROVED TO MEET STAGE IIIB AND IV LIMIT VALUES.**

Parameter	Unit	Limits ⁰		Test Method
		Minimum	Maximum	
Cetane number ⁰			54,0	EN-ISO 5165
Density at 15°C	kg/m ³	833	837	EN-ISO 3675
Distillation:				
50% point	°C	245		EN-ISO 3405
95% point	°C	345	350	EN-ISO 3405
- Final boiling point	°C		370	EN-ISO 3405
Flash point	°C	55		EN 22719
CFPP	°C		-5	EN 116
Viscosity at 40°C	mm ² /s	2,3	3,3	EN-ISO 3104
Polycyclic aromatic hydrocarbons	% m/m	3,0	6,0	IP 391
Sulphur content ⁰	mg/kg		10	ASTM D 5453
Copper corrosion			class 1	EN-ISO 2160
Conradson carbon residue (10% DR)	% m/m		0,2	EN-ISO 10370
Ash content	% m/m		0,01	EN-ISO 6245
Parameter	Unit	Limits ^a		Test Method
		Minimum	maximum	
Water content	% m/m		0,02	EN-ISO 12937
Neutralisation (strong acid) number	mg KOH/g		0,02	ASTM D 974
Oxidation stability ^d	mg/ml		0,025	EN-ISO 12205
Lubricity (HFRR wear)	µm		400	CEC F-06-A-96

Status: EU Directives are being published on this site to aid cross referencing from UK legislation. After IP completion day (31 December 2020 11pm) no further amendments will be applied to this version.

scar diameter at 60°C)				
FAME	prohibited			
a	<p>The values quoted in the specifications are "true values". In establishment of their limit values the terms of ISO 4259 "Petroleum products - Determination and application of precision data in relation to methods of test" have been applied and in fixing a minimum value, a minimum difference of 2R above zero has been taken into account; in fixing a maximum and minimum value, the minimum difference is 4R (R = reproducibility). Notwithstanding this measure, which is necessary for technical reasons, the manufacturer of fuels should nevertheless aim at a zero value where the stipulated maximum value is 2R and at the mean value in the case of quotations of maximum and minimum limits. Should it be necessary to clarify the questions as to whether a fuel meets the requirements of the specifications, the terms of ISO 4259 should be applied.</p>			
b	<p>The range for cetane number is not in accordance with the requirements of a minimum range of 4R. However, in the case of a dispute between fuel supplier and fuel user, the terms of ISO 4259 may be used to resolve such disputes provided replicate measurements, of sufficient number to archive the necessary precision, are made in preference to single determinations.</p>			
c	<p>The actual sulphur content of the fuel used for the Type I test shall be reported.</p>			
d	<p>Even though oxidation stability is controlled, it is likely that shelf life will be limited. Advice should be sought from the supplier as to storage conditions and life.</p>			

4. ANNEX VII SHALL BE AMENDED AS FOLLOWS:

APPENDIX 1 SHALL BE REPLACED BY THE FOLLOWING:

"Appendix 1

TEST RESULTS FOR COMPRESSION IGNITION ENGINES TEST RESULTS

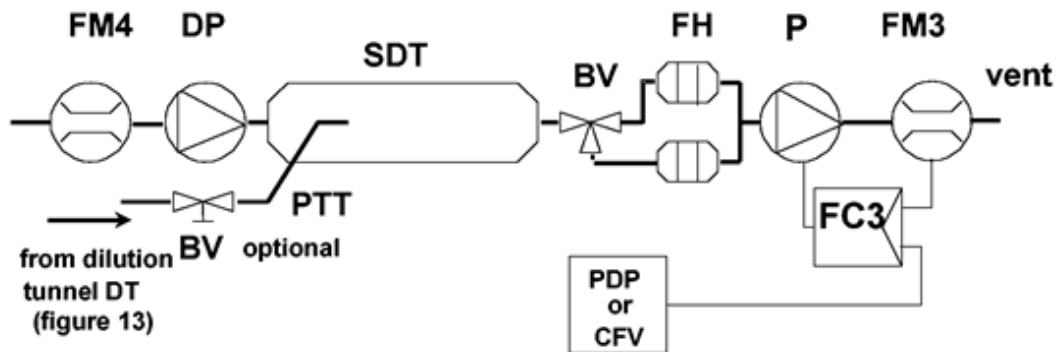

Status: EU Directives are being published on this site to aid cross referencing from UK legislation. After IP completion day (31 December 2020 11pm) no further amendments will be applied to this version.

1. INFORMATION CONCERNING THE CONDUCT OF THE NRSC TEST ¹:

1.1. Reference fuel used for test

1.1.1. Cetane number:

1.1.2. Sulphur content:

1.1.3. Density

1.2. Lubricant

1.2.1. Make(s):

1.2.2. Type(s):

(state percentage of oil in mixture if lubricant and fuel are mixed)

1.3. Engine driven equipment (if applicable)

1.3.1. Enumeration and identifying details:

1.3.2. Power absorbed at indicated engine speeds (as specified by the manufacturer):

Equipment	Power P _{AE} (kW) absorbed at various engine speeds ¹ , taking into account Appendix 3 of this Annex	
	Intermediate (if applicable)	Rated
Total:		

¹ Must not be greater than 10% of the power measured during the test.

1.4. Engine performance

1.4.1. Engine speeds:

Idle:rpm

Intermediate: rpm

Rated: rpm

¹ For the case of several parent engines to be indicated for each of them.

Status: EU Directives are being published on this site to aid cross referencing from UK legislation. After IP completion day (31 December 2020 11pm) no further amendments will be applied to this version.

1.4.2. Engine power ¹

Condition	Power setting (kW) at various engine speeds	
	Intermediate (if applicable)	Rated
Maximum power measured on test (P _M) (kW) (a)		
Total power absorbed by engine driven equipment as per section 1.3.2 of this Appendix, or section 3.1 of Annex III (P _{AE}) (kW) (b)		
Net engine power as specified in section 2.4 of Annex I (kW) (c)		
c = a + b		

1.5. Emission levels

1.5.1. Dynamometer setting (kW)

Percent Load	Dynamometer setting (kW) at various engine speeds	
	Intermediate (if applicable)	Rated
10 (if applicable)		
25 (if applicable)		
50		
75		
100		

1.5.2. Emission results on the NRSC test :

CO:g/kWh
 HC:g/kWh
 NOx:g/kWh
 NMHC+NOx:g/kWh
 Particulates:g/kWh

1.5.3. Sampling system used for the NRSC test:

1.5.3.1. Gaseous emissions ¹:.....

1.5.3.2. Particulates ¹:.....

1.5.3.2.1. Method ²: single/multiple filter

2. INFORMATION CONCERNING THE CONDUCT OF THE NRTC TEST ³:

2.1. Emission results on the NRTC test:

CO:g/kWh
 NMHC:g/kWh
 NOx:g/kWh
 Particulates:g/kWh
 NMHC+NOx :g/kWh

¹ Uncorrected power measured in accordance with section 2.4 of Annex I.
¹ Indicate figure numbers defined in Annex VI section I.
² Delete as appropriate.
³ For the case of several parent engines, to be indicated for each of them.

5. ANNEX XII SHALL BE AMENDED AS FOLLOWS:

Status: EU Directives are being published on this site to aid cross referencing from UK legislation. After IP completion day (31 December 2020 11pm) no further amendments will be applied to this version.

The following section shall be added:

3. For engines categories H, I, and J (stage IIIA) and engines category K, L and M (stage IIIB) as defined in Article 9 section 3, the following type-approvals and, where applicable, the pertaining approval marks are recognised as being equivalent to an approval to this Directive;
 - 3.1. Type-approvals to Directive 88/77/EEC, as amended by Directive 99/96/EC, which are in compliance with stages B1, B2 or C provided for in Article 2 and section 6.2.1 of Annex I.
 - 3.2. UN-ECE Regulation 49.03 series of amendments which are in compliance with stages B1, B2 and C provided for in paragraph 5.2.

ANNEX II

"Annex VI

ANALYTICAL AND SAMPLING SYSTEM

1. GASEOUS AND PARTICULATE SAMPLING SYSTEMS

Figure Number	Description
2	Exhaust gas analysis system for raw exhaust
3	Exhaust gas analysis system for dilute exhaust
4	Partial flow, isokinetic flow, suction blower control, fractional sampling
5	Partial flow, isokinetic flow, pressure blower control, fractional sampling
6	Partial flow, CO ₂ or NO _x control, fractional sampling
7	Partial flow, CO ₂ or carbon balance, total sampling
8	Partial flow, single venturi and concentration measurement, fractional sampling
9	Partial flow, twin venturi or orifice and concentration measurement, fractional sampling
10	Partial flow, multiple tube splitting and concentration measurement, fractional sampling
11	Partial flow, flow control, total sampling
12	Partial flow, flow control, fractional sampling

Status: EU Directives are being published on this site to aid cross referencing from UK legislation. After IP completion day (31 December 2020 11pm) no further amendments will be applied to this version.

13	Full flow, positive displacement pump or critical flow venturi, fractional sampling
14	Particulate sampling system
15	Dilution system for full flow system

1.1. Determination of the gaseous emissions

Section 1.1.1 and Figures 2 and 3 contain detailed descriptions of the recommended sampling and analysing systems. Since various configurations can produce equivalent results, exact conformance with these figures is not required. Additional components such as instruments, valves, solenoids, pumps and switches may be used to provide additional information and coordinate the functions of the component systems. Other components which are not needed to maintain the accuracy on some systems, may be excluded if their exclusion is based upon good engineering judgement.

1.1.1. Gaseous exhaust components CO, CO₂, HC, NO_x

An analytical system for the determination of the gaseous emissions in the raw or diluted exhaust gas is described based on the use of:

- HFID analyser for the measurement of hydrocarbons,
- NDIR analysers for the measurement of carbon monoxide and carbon dioxide,
- HCLD or equivalent analyser for the measurement of nitrogen oxide.

For the raw exhaust gas (Figure 2), the sample for all components may be taken with one sampling probe or with two sampling probes located in close proximity and internally split to the different analysers. Care must be taken that no condensation of exhaust components (including water and sulphuric acid) occurs at any point of the analytical system.

For the diluted exhaust gas (Figure 3), the sample for the hydrocarbons shall be taken with another sampling probe than the sample for the other components. Care must be taken that no condensation of exhaust components (including water and sulphuric acid) occurs at any point of the analytical system.

Figure 2

Status: EU Directives are being published on this site to aid cross referencing from UK legislation. After IP completion day (31 December 2020 11pm) no further amendments will be applied to this version.

Flow diagram of exhaust gas analysis system for CO, NOx and HC

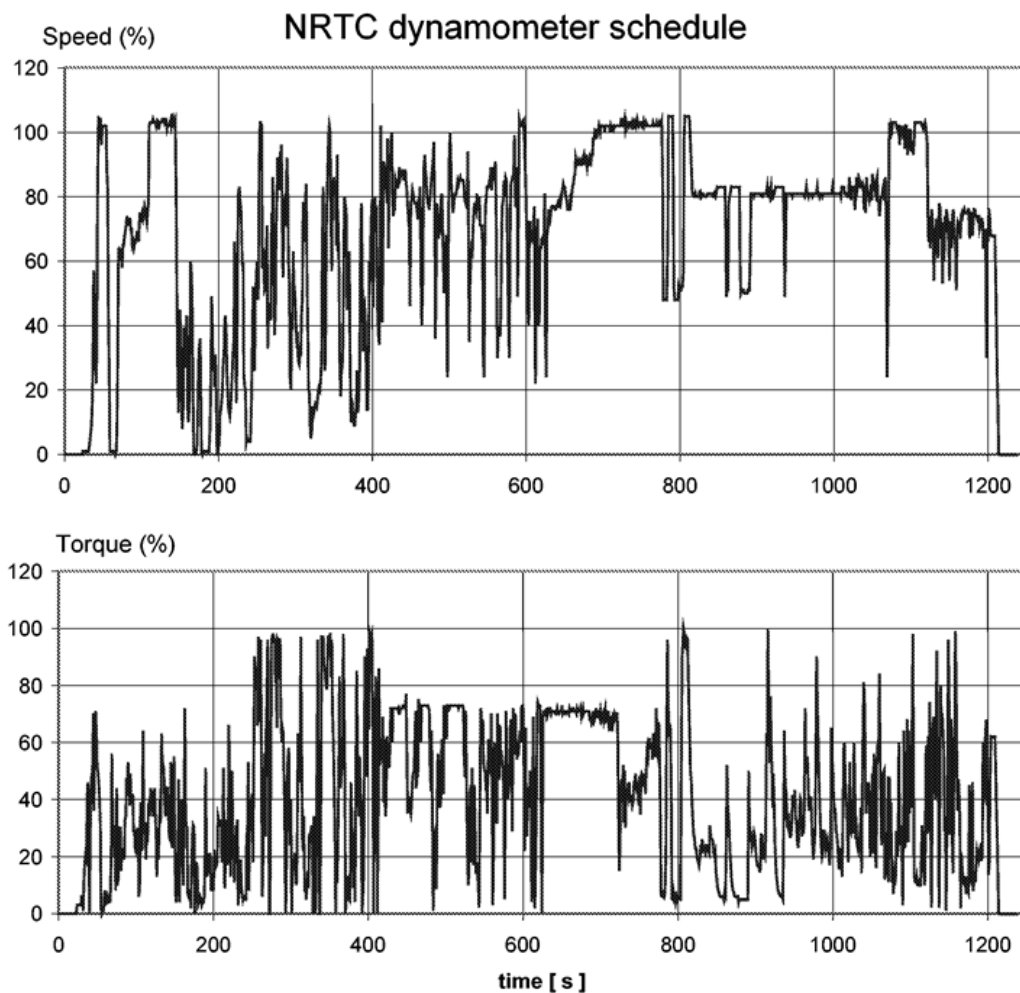
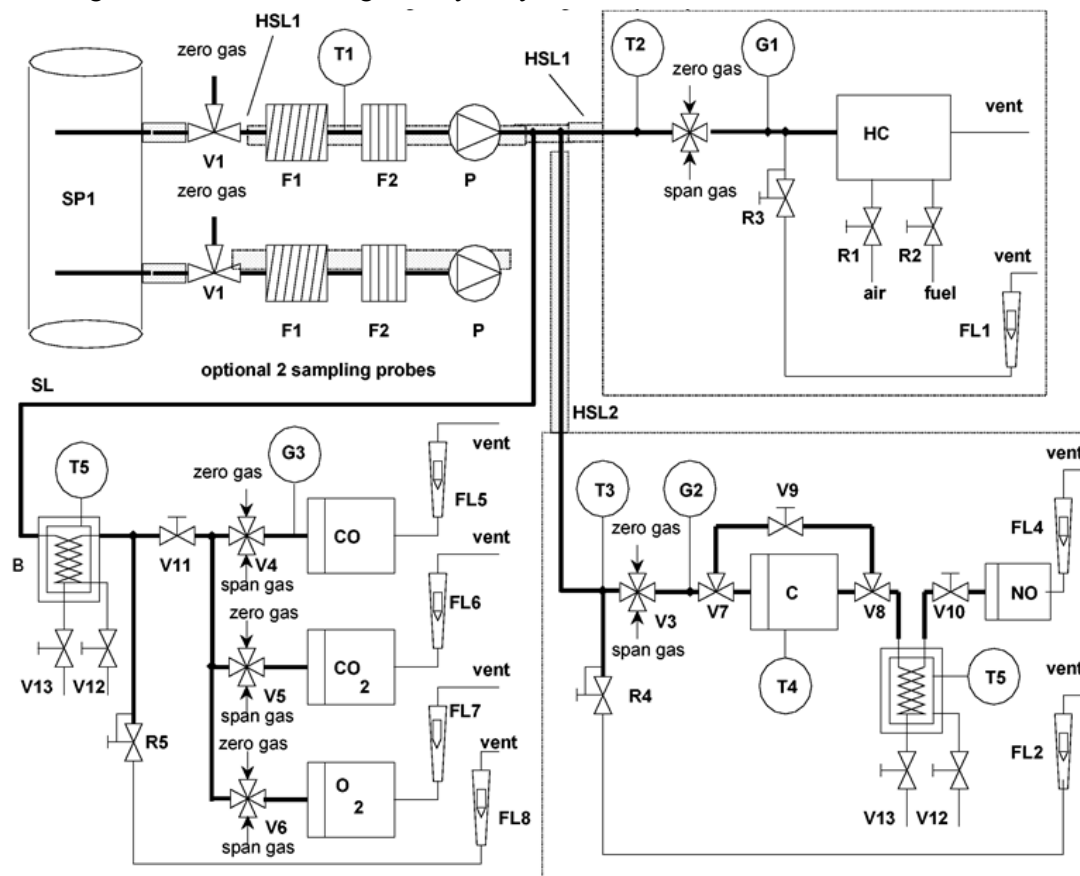

Figure 3

Flow diagram of dilute exhaust gas analysis system for CO, CO₂, NO_x and HC

Descriptions – Figures 2 and 3

General statement:

All components in the sampling gas path must be maintained at the temperature specified for the respective systems.

- SP1 raw exhaust gas sampling probe (Figure 2 only)

A stainless steel straight closed and multihole probe is recommended. The inside diameter shall not be greater than the inside diameter of the sampling line. The wall thickness of the probe shall not be greater than 1 mm. There shall be a minimum of three holes in three different radial planes sized to sample approximately the same flow. The probe must extend across at least 80% of the diameter of the exhaust pipe.

- SP2 dilute exhaust gas HC sampling probe (Figure 3 only)

The probe shall:

- be defined as the first 254 mm to 762 mm of the hydrocarbon sampling line (HSL3),
- have a 5 mm minimum inside diameter,
- be installed in the dilution tunnel DT (section 1.2.1.2) at a point where the dilution air and exhaust gas are well mixed (i.e. approximately 10 tunnel diameters downstream of the point where the exhaust enters the dilution tunnel),

Status: EU Directives are being published on this site to aid cross referencing from UK legislation. After IP completion day (31 December 2020 11pm) no further amendments will be applied to this version.

- be sufficiently distant (radially) from other probes and the tunnel wall so as to be free from the influence of any wakes or eddies,
- be heated so as to increase the gas stream temperature to $463\text{ K } (190^{\circ}\text{C}) \pm 10\text{ K}$ at the exit of the probe.
- SP3 dilute exhaust gas CO, CO₂, NO_x sampling probe (Figure 3 only)

The probe shall:

- be in the same plane as SP2,
- be sufficiently distant (radially) from other probes and the tunnel wall so as to be free from the influence of any wakes or eddies,
- be heated and insulated over its entire length to a minimum temperature of $328\text{ K } (55^{\circ}\text{C})$ to prevent water condensation.
- HSL1 heated sampling line

The sampling line provides gas sampling from a single probe to the split point(s) and the HC analyser.

The sampling line shall:

- have a 5 mm minimum and a 13,5 mm maximum inside diameter,
- be made of stainless steel or PTFE,
- maintain a wall temperature of $463\text{ K } (190^{\circ}\text{C}) \pm 10\text{ K}$ as measured at every separately controlled heated section, if the temperature of the exhaust gas at the sampling probe is equal or below $463\text{ K } (190^{\circ}\text{C})$,
- maintain a wall temperature greater than $453\text{ K } (180^{\circ}\text{C})$ if the temperature of the exhaust gas at the sampling probe is above $463\text{ K } (190^{\circ}\text{C})$,
- maintain a gas temperature of $463\text{ K } (190^{\circ}\text{C}) \pm 10\text{ K}$ immediately before the heated filter (F2) and the HFID.
- HSL2 heated NO_x sampling line

The sampling line shall:

- maintain a wall temperature of $328\text{ to }473\text{ K } (55\text{ to }200^{\circ}\text{C})$ up to the converter when using a cooling bath, and up to the analyser when a cooling bath is not used,
- be made of stainless steel or PTFE.

Since the sampling line need only be heated to prevent condensation of water and sulphuric acid, the samplingline temperature will depend on the sulphur content of the fuel.

- SL sampling line for CO (CO₂)

The line shall be made of PTFE or stainless steel. It may be heated or unheated.

- BK background bag (optional; Figure 3 only)
 - For the measurement of the background concentrations.
- BG sample bag (optional; Figure 3 CO and CO₂ only)
 - For the measurement of the sample concentrations.
- F1 heated pre-filter (optional)

The temperature shall be the same as HSL1.

Status: EU Directives are being published on this site to aid cross referencing from UK legislation. After IP completion day (31 December 2020 11pm) no further amendments will be applied to this version.

- F2 heated filter
The filter shall extract any solid particles from the gas sample prior to the analyser. The temperature shall be the same as HSL1. The filter shall be changed as needed.
- P heated sampling pump
The pump shall be heated to the temperature of HSL1.
- HC
Heated flame ionization detector (HFID) for the determination of the hydrocarbons. The temperature shall be kept at 453 to 473 K (180 to 200°C).
- CO, CO₂
NDIR analysers for the determination of carbon monoxide and carbon dioxide.
- NO₂
(H)CLD analyser for the determination of the oxides of nitrogen. If a HCLD is used it shall be kept at a temperature of 328 to 473 K (55 to 200°C).
- C converter
A converter shall be used for the catalytic reduction of NO₂ to NO prior to analysis in the CLD or HCLD.
- B cooling bath
To cool and condense water from the exhaust sample. The bath shall be maintained at a temperature of 273 to 277 K (0 to 4°C) by ice or refrigeration. It is optional if the analyser is free from water vapour interference as determined in Annex III, Appendix 2, sections 1.9.1 and 1.9.2.
Chemical dryers are not allowed for removing water from the sample.
- T1, T2, T3 temperature sensor
To monitor the temperature of the gas stream.
- T4 temperature sensor Temperature of the NO₂-NO converter.
- T5 temperature sensor
To monitor the temperature of the cooling bath.
- G1, G2, G3 pressure gauge
To measure the pressure in the sampling lines.
- R1, R2 pressure regulator
To control the pressure of the air and the fuel, respectively, for the HFID.
- R3, R4, R5 pressure regulator
To control the pressure in the sampling lines and the flow to the analysers.
- FL1, FL2, FL3 flow meter
To monitor the sample bypass flow.
- FL4 to FL7 flow meter (optional)
To monitor the flow rate through the analysers.

Status: EU Directives are being published on this site to aid cross referencing from UK legislation. After IP completion day (31 December 2020 11pm) no further amendments will be applied to this version.

- V1 to V6 selector valve
- Suitable valving for selecting sample, span gas or zero gas flow to the analyser.
- V7, V8 solenoid valve
 - To bypass the NO₂-NO converter.
 - V9 needle valve
 - To balance the flow through the NO₂-NO converter and the bypass.
 - V10, V11 needle valve
 - To regulate the flows to the analysers.
 - V12, V13 toggle valve
 - To drain the condensate from the bath B.
 - V14 selector valve
 - Selecting the sample or background bag.

1.2. Determination of the particulates

Sections 1.2.1 and 1.2.2 and Figures 4 to 15 contain detailed descriptions of the recommended dilution and sampling systems. Since various configurations can produce equivalent results, exact conformance with these figures is not required. Additional components such as instruments, valve, solenoids, pumps and switches may be used to provide additional information and coordinate the functions of the component systems. Other components which are not needed to maintain the accuracy on some systems, may be excluded if their exclusion is based on good engineering judgement.

1.2.1. Dilution system

1.2.1.1. Partial flow dilution system (Figures 4 to 12)⁽¹⁹⁾

A dilution system is described based on the dilution of a part of the exhaust stream. Splitting of the exhaust stream and the following dilution process may be done by different dilution system types. For subsequent collection of the particulates, the entire dilute exhaust gas or only a portion of the dilute exhaust gas may be passed to the particulate sampling system (section 1.2.2, Figure 14). The first method is referred to as total sampling type, the second method as fractional sampling type. The calculation of the dilution ratio depends on the type of system used. The following types are recommended:

- isokinetic systems (Figures 4 and 5)

With these systems, the flow into the transfer tube is matched to the bulk exhaust flow in terms of gas velocity and/or pressure, thus requiring an undisturbed and uniform exhaust flow at the sampling probe. This is usually achieved by using a resonator and a straight approach tube upstream of the sampling point. The split ratio is then calculated from easily measurable values like tube diameters. It should be noted that isokinetic is only used for matching the flow conditions and not for matching the size distribution. The latter is typically not necessary, as the particles are sufficiently small as to follow the fluid streamlines,

- flow controlled systems with concentration measurement (Figures 6 to 10)

With these systems, a sample is taken from the bulk exhaust stream by adjusting the dilution air flow and the total dilution exhaust flow. The dilution ratio is determined from the concentrations of tracer gases, such as CO₂ or NO_x, naturally occurring in the engine exhaust. The concentrations in the dilution exhaust gas and in the dilution air

Status: EU Directives are being published on this site to aid cross referencing from UK legislation. After IP completion day (31 December 2020 11pm) no further amendments will be applied to this version.

are measured, whereas the concentration in the raw exhaust gas can be either measured directly or determined from fuel flow and the carbon balance equation, if the fuel composition is known. The systems may be controlled by the calculated dilution ratio (Figures 6 and 7) or by the flow into the transfer tube (Figures 8, 9 and 10),
— flow controlled systems with flow measurement (Figures 11 and 12)

With these systems, a sample is taken from the bulk exhaust stream by setting the dilution air flow and the total dilution exhaust flow. The dilution ratio is determined from the difference of the two flow rates. Accurate calibration of the flow meters relative to one another is required, since the relative magnitude of the two flow rates can lead to significant errors at higher dilution ratios. Flow control is very straightforward by keeping the dilute exhaust flow rate constant and varying the dilution air flow rate, if needed.

In order to realise the advantages of the partial flow dilution systems, attention must be paid to avoiding the potential problems of loss of particulates in the transfer tube, ensuring that a representative sample is taken from the engine exhaust, and determination of the split ratio.

The systems described pay attention to these critical areas.

Figure 4

Partial flow dilution system with isokinetic probe and fractional sampling (SB control)

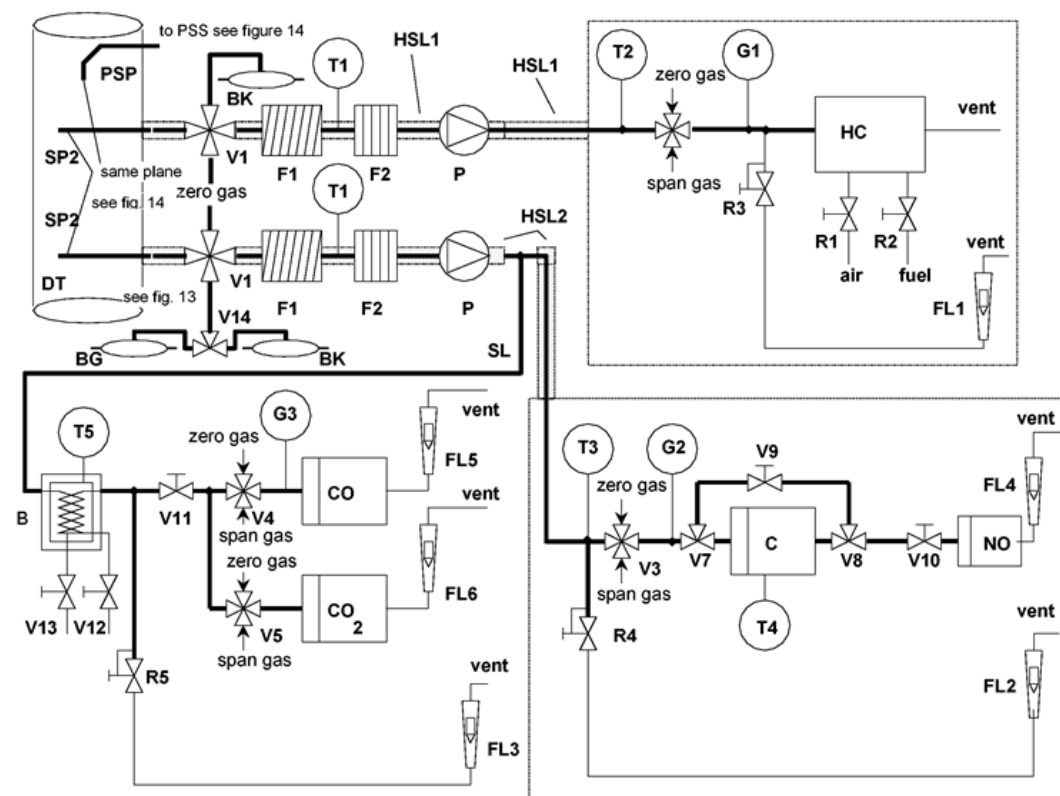

Raw exhaust gas is transferred from the exhaust pipe to EP to the dilution tunnel DT through the transfer tube TT by the isokinetic sampling probe ISP. The differential pressure of the exhaust gas between exhaust pipe and inlet to the probe is measured with the pressure transducer DPT. This signal is transmitted to the flow controller FC1 that controls the suction blower SB to maintain a differential pressure of zero at the tip of the probe. Under these conditions, exhaust

Status: EU Directives are being published on this site to aid cross referencing from UK legislation. After IP completion day (31 December 2020 11pm) no further amendments will be applied to this version.

gas velocities in EP and ISP are identical, and the flow through ISP and TT is a constant fraction (split) of the exhaust gas flow. The split ratio is determined from the cross sectional areas of EP and ISP. The dilution air flow rate is measured with the flow measurement device FM1. The dilution ratio is calculated from the dilution air flow rate and the split ratio.

Figure 5

Partial flow dilution system with isokinetic probe and fractional sampling (PB control)

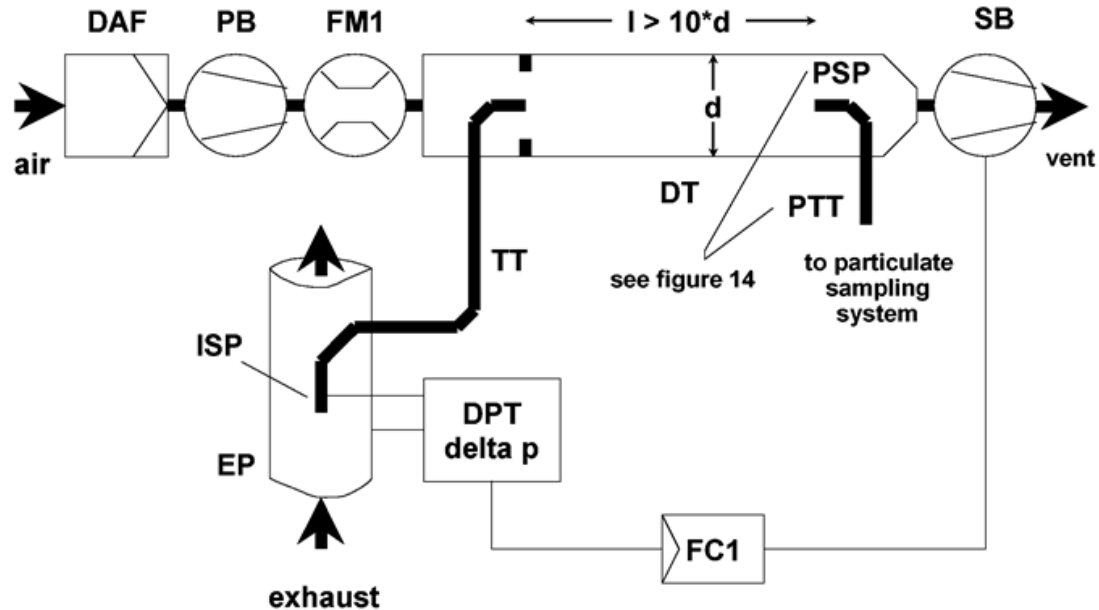

Raw exhaust gas is transferred from the exhaust pipe EP to the dilution tunnel DT through the transfer tube TT by the isokinetic sampling probe ISP. The differential pressure of the exhaust gas between exhaust pipe and inlet to the probe is measured with the pressure transducer DPT. This signal is transmitted to the flow controller FC1 that controls the pressure blower PB to maintain a differential pressure of zero at the tip of the probe. This is done by taking a small fraction of the dilution air whose flow rate has already been measured with the flow measurement device FM1, and feeding it to TT by means of a pneumatic orifice. Under these conditions, exhaust gas velocities in EP and ISP are identical, and the flow through ISP and TT is a constant fraction (split) of the exhaust gas flow. The split ratio is determined from the cross sectional areas of EP and ISP. The dilution air is sucked through DT by the suction blower SB, and the flow rate is measured with FM1 at the inlet to DT. The dilution ratio is calculated from the dilution air flow rate and the split ratio.

Figure 6

Partial flow dilution system with CO₂ or NO_x concentration measurement and fractional sampling

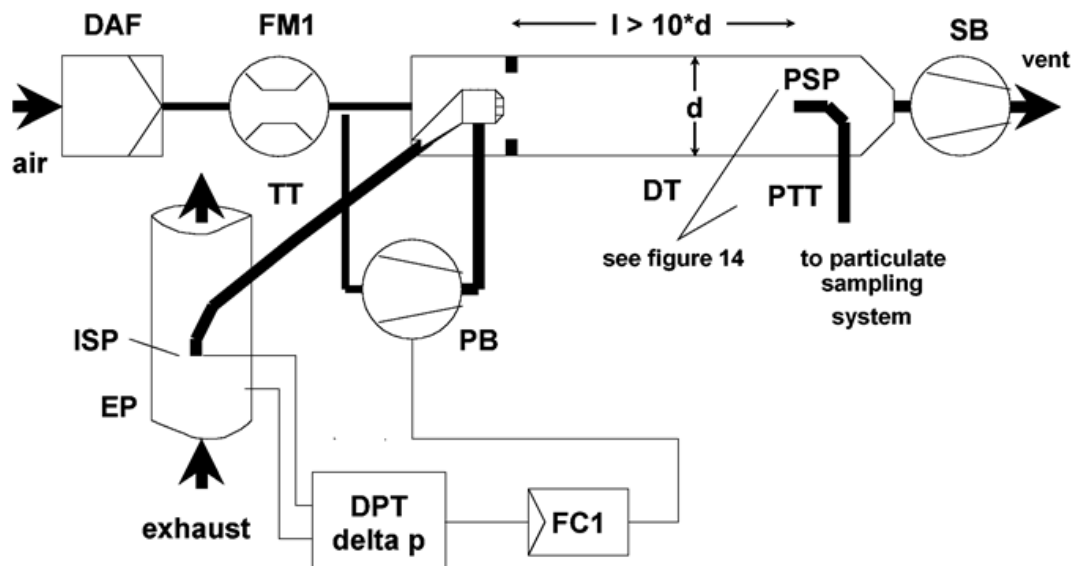

Raw exhaust gas is transferred from the exhaust pipe EP to the dilution tunnel DT through the sampling probe SP and the transfer tube TT. The concentrations of a tracer gas (CO₂ or NO_x) are measured in the raw and diluted exhaust gas as well as in the dilution air with the exhaust gas analyser(s) EGA. These signals are transmitted to the flow controller FC2 that controls either the pressure blower PB or the suction blower SB to maintain the desired exhaust split and dilution ratio in DT. The dilution ratio is calculated from the tracer gas concentrations in the raw exhaust gas, the diluted exhaust gas, and the dilution air.

Figure 7

Status: EU Directives are being published on this site to aid cross referencing from UK legislation. After IP completion day (31 December 2020 11pm) no further amendments will be applied to this version.

Partial flow dilution system with CO₂ concentration measurement, carbon balance and total sampling

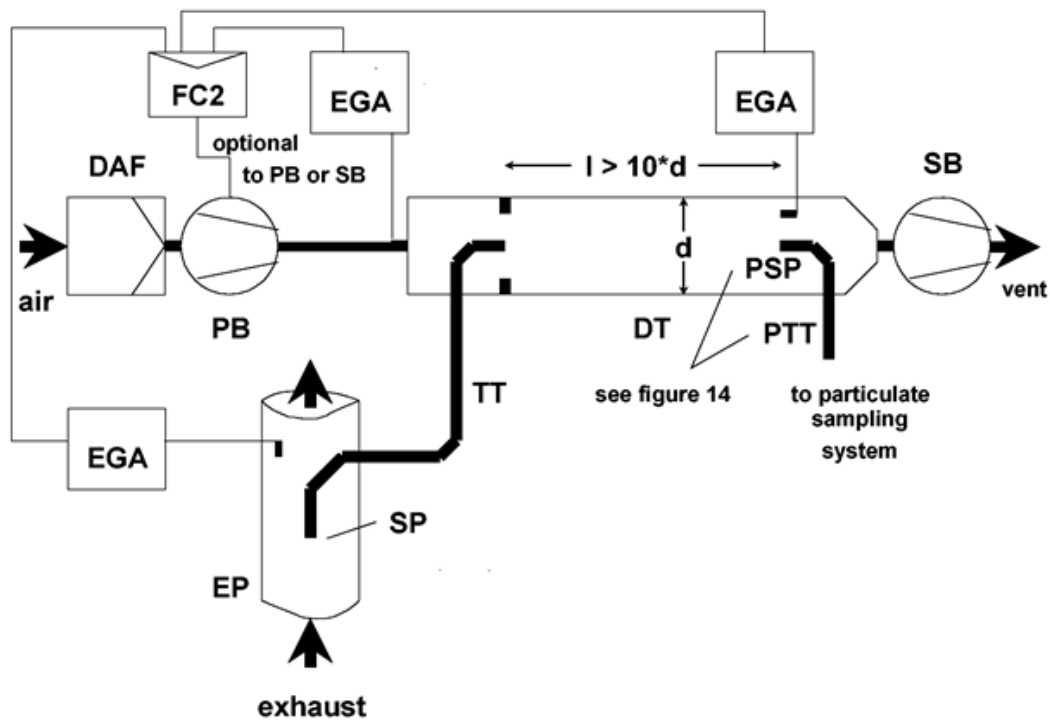

Raw exhaust gas is transferred from the exhaust pipe EP to the dilution tunnel DT through the sampling probe SP and the transfer tube TT. The CO₂ concentrations are measured in the diluted exhaust gas and in the dilution air with the exhaust gas analyser(s) EGA. The CO₂ and fuel flow GFUEL signals are transmitted either to the flow controller FC2, or to the flow controller FC3 of the particulate sampling system (Figure 14). FC2 controls the pressure blower PB, while FC3 controls the particulate sampling system (Figure 14), thereby adjusting the flows into and out of the system so as to maintain the desired exhaust split and dilution ratio in DT. The dilution ratio is calculated from the CO₂ concentrations and GFUEL using the carbon balance assumption.

Figure 8

Partial flow dilution system with single venturi, concentration measurement and fractional sampling

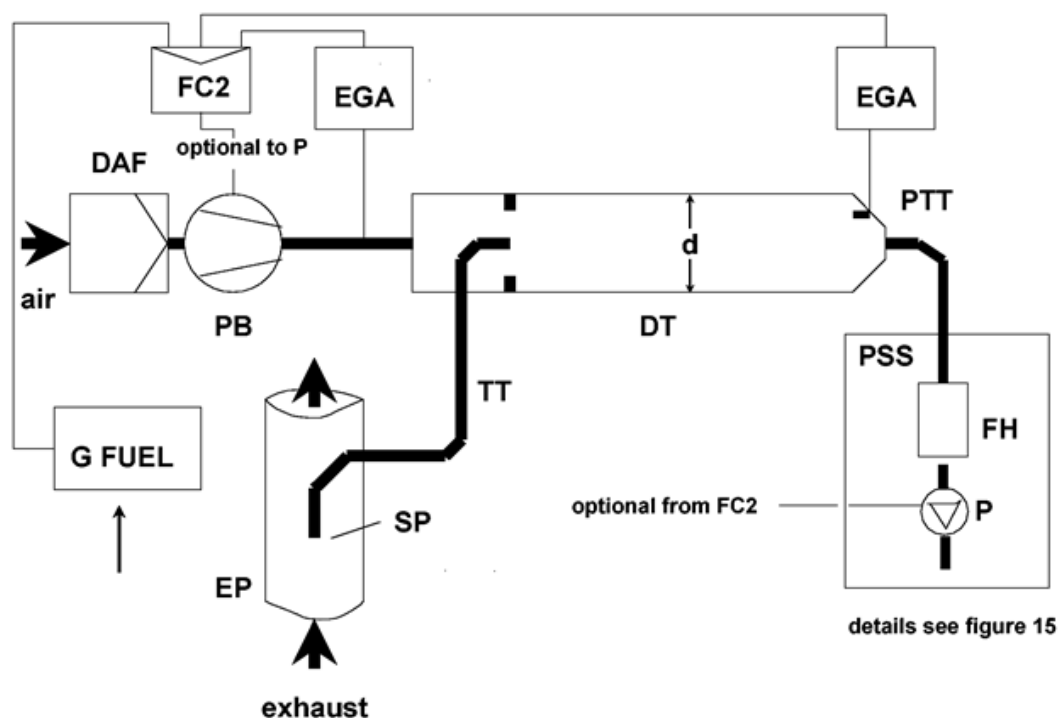

Raw exhaust gas is transferred from the exhaust pipe EP to the dilution tunnel DT through the sampling probe SP and the transfer tube TT due to the negative pressure created by the venturi VN in DT. The gas flow rate through TT depends on the momentum exchange at the venturi zone, and is therefore affected by the absolute temperature of the gas at the exit of TT. Consequently, the exhaust split for a given tunnel flow rate is not constant, and the dilution ratio at low load is slightly lower than at high load. The tracer gas concentrations (CO_2 or NO_x) are measured in the raw exhaust gas, the diluted exhaust gas, and the dilution air with the exhaust gas analyser(s) EGA, and the dilution ratio is calculated from the values so measured.

Figure 9

Status: EU Directives are being published on this site to aid cross referencing from UK legislation. After IP completion day (31 December 2020 11pm) no further amendments will be applied to this version.

Partial flow dilution system twin venturi or twin orifice, concentration measurement and fractional sampling

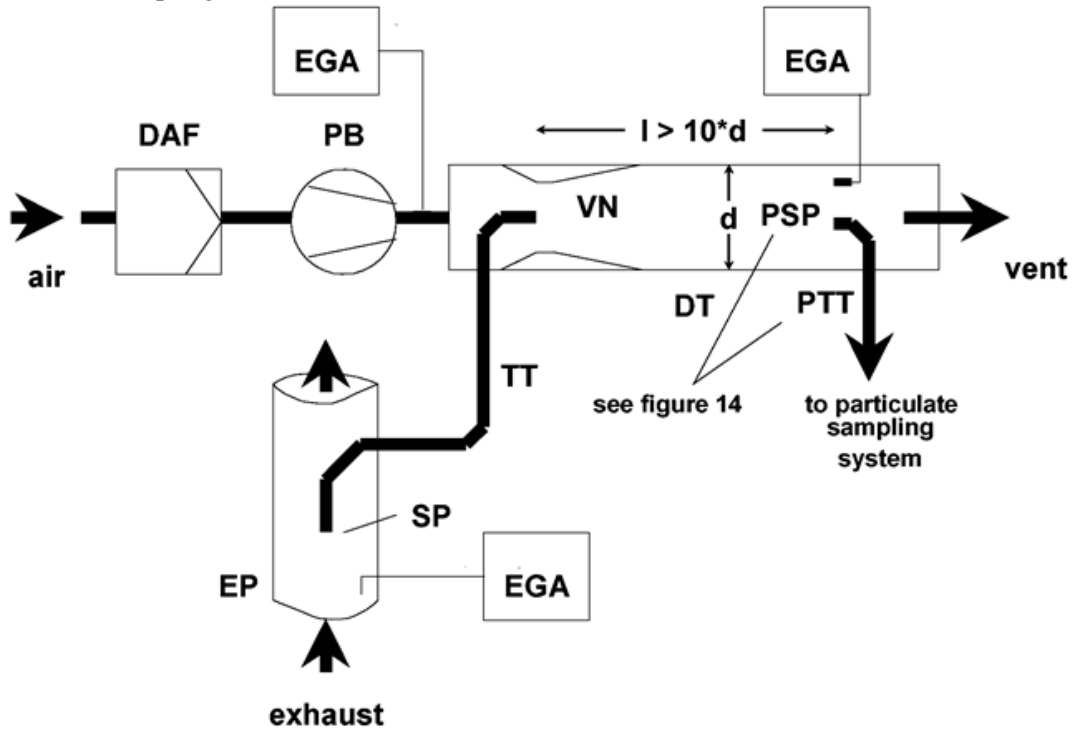

Raw exhaust gas is transferred from the exhaust pipe EP to the dilution tunnel DT through the sampling probe SP and the transfer tube TT by a flow divider that contains a set of orifices or venturis. The first one (FD1) is located in EP, the second one (FD2) in TT. Additionally, two pressure control valves (PCV1 and PCV2) are necessary to maintain a constant exhaust split by controlling the backpressure in EP and the pressure in DT. PCV1 is located downstream of SP in EP, PCV2 between the pressure blower PB and DT. The tracer gas concentrations (CO_2 or NO_x) are measured in the raw exhaust gas, the diluted exhaust gas, and the dilution air with the exhaust gas analyser(s) EGA. They are necessary for checking the exhaust split, and may be used to adjust PCV1 and PCV2 for precise split control. The dilution ratio is calculated from the tracer gas concentrations.

Figure 10

Partial flow dilution system with multiple tube splitting, concentration measurement and fractional sampling

L 146/92

EN

Official Journal of the European Union

30.4.2004

Figure 9

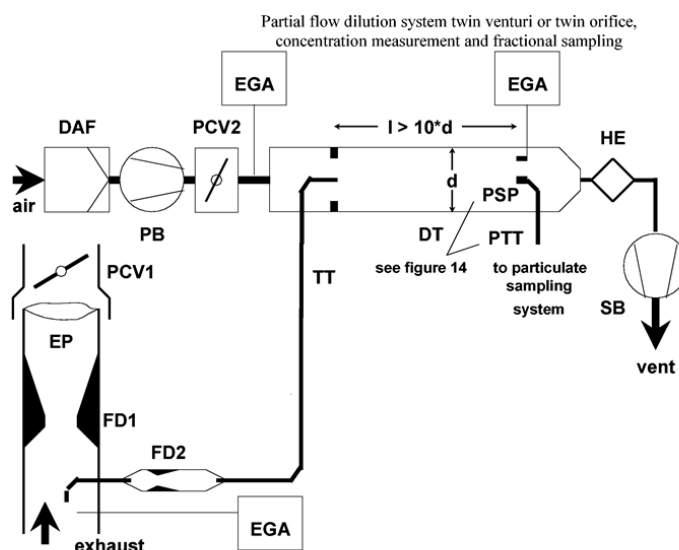

Raw exhaust gas is transferred from the exhaust pipe EP to the dilution tunnel DT through the sampling probe SP and the transfer tube TT by a flow divider that contains a set of orifices or venturis. The first one (FD1) is located in EP, the second one (FD2) in TT. Additionally, two pressure control valves (PCV1 and PCV2) are necessary to maintain a constant exhaust split by controlling the backpressure in EP and the pressure in DT. PCV1 is located downstream of SP in EP, PCV2 between the pressure blower PB and DT. The tracer gas concentrations (CO_2 or NO_x) are measured in the raw exhaust gas, the diluted exhaust gas, and the dilution air with the exhaust gas analyser(s) EGA. They are necessary for checking the exhaust split, and may be used to adjust PCV1 and PCV2 for precise split control. The dilution ratio is calculated from the tracer gas concentrations.

Status: EU Directives are being published on this site to aid cross referencing from UK legislation. After IP completion day (31 December 2020 11pm) no further amendments will be applied to this version.

Raw exhaust gas is transferred from the exhaust pipe EP to the dilution tunnel DT through the transfer tube TT by the flow divider FD3 that consists of a number of tubes of the same dimensions (same diameter, length and bed radius) installed in EP. The exhaust gas through one of these tubes is lead to DT, and the exhaust gas through the rest of the tubes is passed through the damping chamber DC. Thus, the exhaust split is determined by the total number of tubes. A constant split control requires a differential pressure of zero between DC and the outlet of TT, which is measured with the differential pressure transducer DPT. A differential pressure of zero is achieved by injecting fresh air into DT at the outlet of TT. The tracer gas concentrations (CO_2 or NO_x) are measured in the raw exhaust gas, the diluted exhaust gas, and the dilution air with the exhaust gas analyser(s) EGA. They are necessary for checking the exhaust split and may be used to control the injection air flow rate for precise split control. The dilution ratio is calculated from the tracer gas concentrations.

Figure 11

Partial flow dilution system with flow control and total sampling

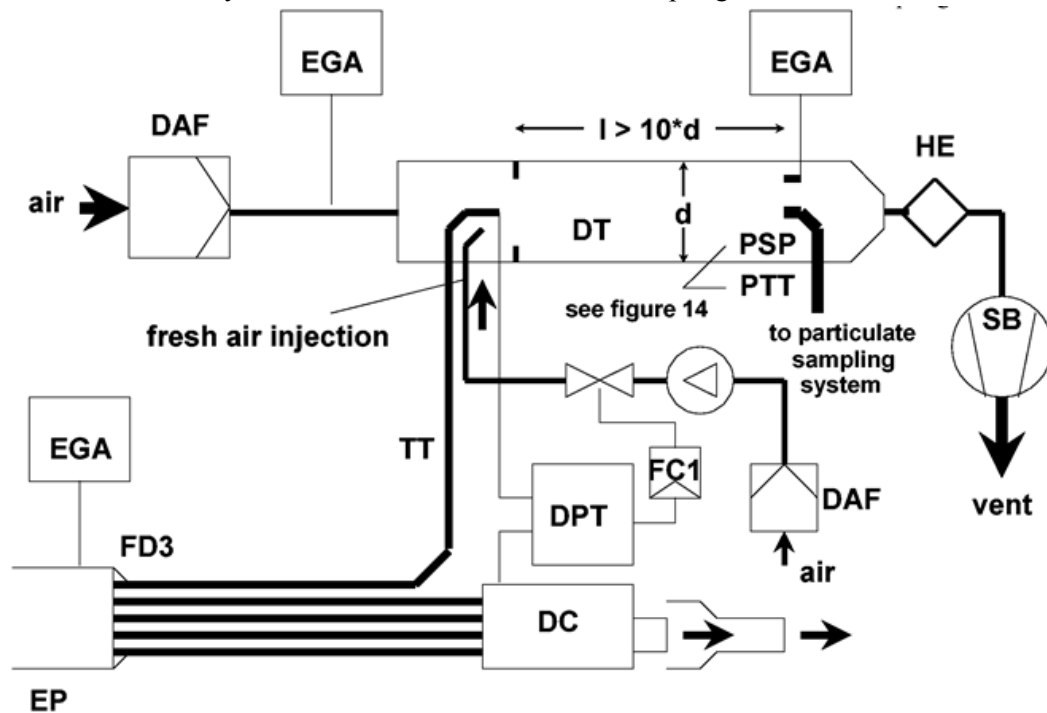

Raw exhaust gas is transferred from the exhaust pipe EP to the dilution tunnel DT through the sampling probe SP and the transfer tube TT. The total flow through the tunnel is adjusted with the flow controller FC3 and the sampling pump P of the particulate sampling system (Figure 16).

The dilution air flow is controlled by the flow controller FC2, which may use G_{EXH} , G_{AIR} or G_{FUEL} as command signals, for the desired exhaust split. The sample flow into DT is the difference of the total flow and the dilution air flow. The dilution air flow rate is measured with flow measurement device FM1, the total flow rate with the flow measurement device FM3 of the particulate sampling system (Figure 14). The dilution ratio is calculated from these two flow rates.

Figure 12

Partial flow dilution system with flow control and fractional sampling

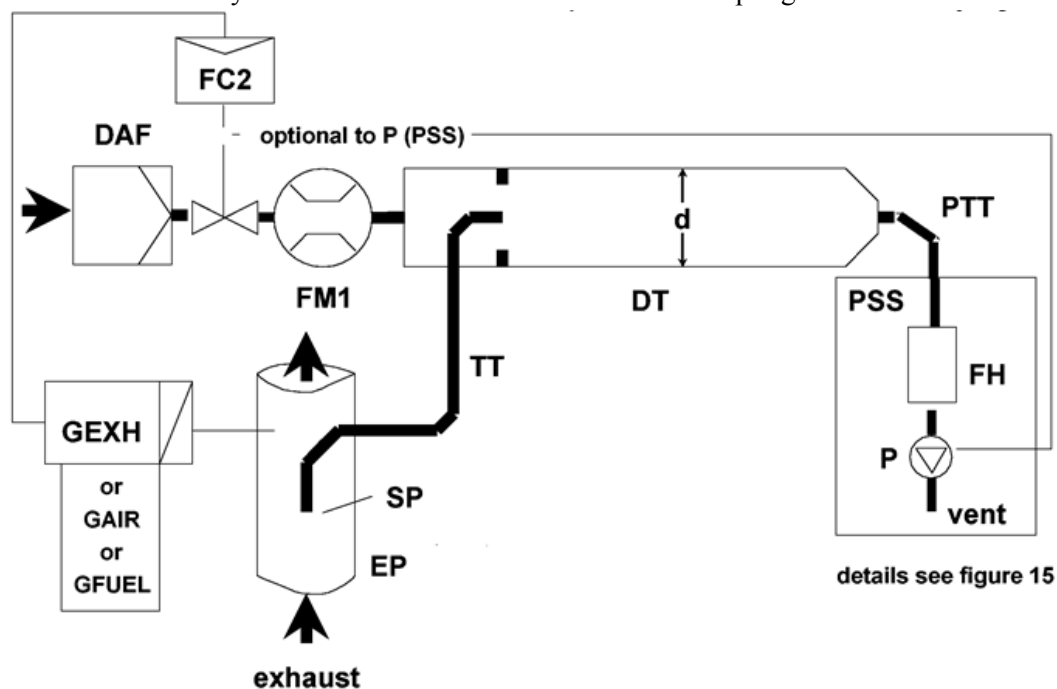

Raw exhaust gas is transferred from the exhaust pipe EP to the dilution tunnel DT through the sampling probe SP and the transfer tube TT. The exhaust split and the flow into DT is controlled by the flow controller FC2 that adjusts the flows (or speeds) of the pressure blower PB and the suction blower SB, accordingly. This is possible since the sample taken with the particulate sampling system is returned into DT. GEXH, GAIR or GFUEL may be used as command signals for FC2. The dilution air flow rate is measured with the flow measurement device FM1, the total flow with the flow measurement device FM2. The dilution ratio is calculated from these two flow rates.

Description - Figures 4 to 12

— EP exhaust pipe

The exhaust pipe may be insulated. To reduce the thermal inertia of the exhaust pipe a thickness to diameter ratio of 0,015 or less is recommended. The use of flexible sections shall be limited to a length to diameter ratio of 12 or less. Bends will be minimised to reduce inertial deposition. If the system includes a test bed silencer, the silencer may also be insulated.

For an isokinetic system, the exhaust pipe must be free of elbows, bends and sudden diameter changes for at least six pipe diameters upstream and three pipe diameters downstream of the tip of the probe. The gas velocity at the sampling zone must be higher than 10 m/s except at idle mode. Pressure oscillations of the exhaust gas must not exceed ± 500 Pa on the average. Any steps to reduce pressure oscillations beyond using a chassis-type exhaust system (including silencer and after-treatment device) must not alter engine performance nor cause the deposition of particulates.

For systems without isokinetic probes, it is recommended to have a straight pipe of six pipe diameters upstream and three pipe diameters downstream of the tip of the probe.

— SP sampling probe (Figures 6 to 12)

Status: EU Directives are being published on this site to aid cross referencing from UK legislation. After IP completion day (31 December 2020 11pm) no further amendments will be applied to this version.

The minimum inside diameter shall be 4 mm. The minimum diameter ratio between exhaust pipe and probe shall be four. The probe shall be an open tube facing upstream on the exhaust pipe centre-line, or a multiple hole probe as described under SP1 in section 1.1.1.

— ISP isokinetic sampling probe (Figures 4 and 5)

The isokinetic sampling probe must be installed facing upstream on the exhaust pipe centre-line where the flow conditions in section EP are met, and designed to provide a proportional sample of the raw exhaust gas. The minimum inside diameter shall be 12 mm.

A control system is necessary for isokinetic exhaust splitting by maintaining a differential pressure of zero between EP and ISP. Under these conditions exhaust gas velocities in EP and ISP are identical and the mass flow through ISP is a constant fraction of the exhaust gas flow. The ISP has to be connected to a differential pressure transducer. The control to provide a differential pressure of zero between EP and ISP is done with blower speed or flow controller.

— FD1, FD2 flow divider (Figure 9)

A set of venturis or orifices is installed in the exhaust pipe EP and in the transfer tube TT, respectively, to provide a proportional sample of the raw exhaust gas. A control system consisting of two pressure control valves PCV1 and PCV2 is necessary for proportional splitting by controlling the pressures in EP and DT.

— FD3 flow divider (Figure 10)

A set of tubes (multiple tube unit) is installed in the exhaust pipe EP to provide a proportional sample of the raw exhaust gas. One of the tubes feeds exhaust gas to the dilution tunnel DT, whereas the other tubes exit exhaust gas to a damping chamber DC. The tubes must have the same dimensions (same diameter, length, bend radius), so that the exhaust split depends on the total number of tubes. A control system is necessary for proportional splitting by maintaining a differential pressure of zero between the exit of the multiple tube unit into DC and the exit of TT. Under these conditions, exhaust gas velocities in EP and FD3 are proportional, and the flow TT is a constant fraction of the exhaust gas flow. The two points have to be connected to a differential pressure transducer DPT. The control to provide a differential pressure of zero is done with the flow controller FC1.

— EGA exhaust gas analyser (Figures 6 to 10)

CO₂ or NO_x analysers may be used (with carbon balance method CO₂ only). The analysers shall be calibrated like the analysers for the measurement of the gaseous emissions. One or several analysers may be used to determine the concentration differences.

The accuracy of the measuring systems has to be such that the accuracy of G_{EDFW,i} is within ± 4%.

— TT transfer tube (Figures 4 to 12)

The particulate sample transfer tube shall be:

- as short as possible, but not more than 5 m in length,
- equal to or greater than the probe diameter, but not more than 25 mm in diameter,
- exiting on the centre-line of the dilution tunnel and pointing down-stream.

If the tube is 1 metre or less in length, it is to be insulated with material with a maximum thermal conductivity of 0,05 W/(m · K) with a radial insulation thickness corresponding to the diameter of the probe. If the tube is longer than 1 metre, it must be insulated and heated to a minimum wall temperature of 523 K (250°C).

Alternatively, the transfer tube wall temperatures required may be determined through standard heat transfer calculations.

— DPT differential pressure transducer (Figures 4, 5 and 10)

The differential pressure transducer shall have a range of ± 500 Pa or less.

— FC1 flow controller (Figures 4, 5 and 10)

For the isokinetic systems (Figures 4 and 5) a flow controller is necessary to maintain a differential pressure of zero between EP and ISP. The adjustment can be done by:

(a) controlling the speed or flow of the suction blower (SB) and keeping the speed of the pressure blower (PB) constant during each mode (Figure 4);

or

(b) adjusting the suction blower (SB) to a constant mass flow of the diluted exhaust and controlling the flow of the pressure blower PB, and therefore the exhaust sample flow in a region at the end of the transfer tube (TT) (Figure 5).

In the case of a pressure controlled system the remaining error in the control loop must not exceed ± 3 Pa. The pressure oscillations in the dilution tunnel must not exceed ± 250 Pa on average.

For a multi-tube system (Figure 10) a flow controller is necessary for proportional exhaust splitting to maintain a differential pressure of zero between the outlet of the multi-tube unit and the exit of TT. The adjustment can be done by controlling the injection air flow rate into DT at the exit of TT.

— PCV1, PCV2 pressure control valve (Figure 9)

Two pressure control valves are necessary for the twin venturi/twin orifice system for proportional flow splitting by controlling the backpressure of EP and the pressure in DT. The valves shall be located downstream of SP in EP and between PB and DT.

— DC damping chamber (Figure 10)

A damping chamber shall be installed at the exit of the multiple tube unit to minimize the pressure oscillations in the exhaust pipe EP.

— VN venturi (Figure 8)

A venturi is installed in the dilution tunnel DT to create a negative pressure in the region of the exit of the transfer tube TT. The gas flow rate through TT is determined by the momentum exchange at the venturi zone, and is basically proportional to the flow rate of the pressure blower PB leading to a constant dilution ratio. Since the momentum exchange is affected by the temperature at the exit of TT and the pressure difference between EP and DT, the actual dilution ratio is slightly lower at low load than at high load.

— FC2 flow controller (Figures 6, 7, 11 and 12; optional)

Status: EU Directives are being published on this site to aid cross referencing from UK legislation. After IP completion day (31 December 2020 11pm) no further amendments will be applied to this version.

A flow controller may be used to control the flow of the pressure blower PB and/or the suction blower SB. It may be connected to the exhaust flow or fuel flow signal and/or to the CO₂ or NO_x differential signal.

When using a pressurized air supply (Figure 11) FC2 directly controls the air flow.

— FM1 flow measurement device (Figures 6, 7, 11 and 12)

Gas meter or other flow instrumentation to measure the dilution air flow. FM1 is optional if PB is calibrated to measure the flow.

— FM2 flow measurement device (Figure 12)

Gas meter or other flow instrumentation to measure the diluted exhaust gas flow. FM2 is optional if the suction blower SB is calibrated to measure the flow.

— PB pressure blower (Figures 4, 5, 6, 7, 8, 9 and 12)

To control the dilution air flow rate, PB may be connected to the flow controllers FC1 or FC2. PB is not required when using a butterfly valve. PB may be used to measure the dilution air flow, if calibrated.

— SB suction blower (Figures 4, 5, 6, 9, 10 and 12)

For fractional sampling systems only. SB may be used to measure the dilute exhaust gas flow, if calibrated.

— DAF dilution air filter (Figures 4 to 12)

It is recommended that the dilution air be filtered and charcoal scrubbed to eliminate background hydrocarbons. The dilution air shall have a temperature of 298 K (25°C) ± 5 K.

At the manufacturer's request the dilution air shall be sampled according to good engineering practice to determine the background particulate levels, which can then be subtracted from the values measured in the diluted exhaust.

— PSP particulate sampling probe (Figures 4, 5, 6, 8, 9, 10 and 12)

The probe is the leading section of PTT and

— shall be installed facing upstream at a point where the dilution air and exhaust gas are well mixed, i.e. on the dilution tunnel DT centre-line of the dilution systems approximately 10 tunnel diameters downstream of the point where the exhaust enters the dilution tunnel,

— shall be 12 mm in minimum inside diameter,

— may be heated to no greater than 325 K (52°C) wall temperature by direct heating or by dilution air preheating, provided the air temperature does not exceed 325 K (52°C) prior to the introduction of the exhaust in the dilution tunnel,

— may be insulated.

— DT dilution tunnel (Figures 4 to 12)

The dilution tunnel:

— shall be of a sufficient length to cause complete mixing of the exhaust and dilution air under turbulent flow conditions,

— shall be constructed of stainless steel with:

— a thickness to diameter ratio of 0,025 or less for dilution tunnels of greater than 75 mm inside diameter,

- a nominal wall thickness of not less than 1,5 mm for dilution tunnels of equal to or less than 75 mm inside diameter,
- shall be at least 75 mm in diameter for the fractional sampling type,
- is recommended to be at least 25 mm in diameter for the total sampling type.
- may be heated to no greater than 325 K (52°C) wall temperature by direct heating or by dilution air preheating, provided the air temperature does not exceed 325 K (52°C) prior to the introduction of the exhaust in the dilution tunnel.
- may be insulated.

The engine exhaust shall be thoroughly mixed with the dilution air. For fractional sampling systems, the mixing quality shall be checked after introduction into service by means of a CO₂ profile of the tunnel with the engine running (at least four equally spaced measuring points). If necessary, a mixing orifice may be used.

NOTE: If the ambient temperature in the vicinity of the dilution tunnel (DT) is below 293 K (20°C), precautions should be taken to avoid particle losses onto the cool walls of the dilution tunnel. Therefore, heating and/or insulating the tunnel within the limits given above is recommended.

At high engine loads, the tunnel may be cooled by a non-aggressive means such as a circulating fan, as long as the temperature of the cooling medium is not below 293 K (20°C).

- HE heat exchanger (Figures 9 and 10)

The heat exchanger shall be of sufficient capacity to maintain the temperature at the inlet to the suction blower SB within ± 11 K of the average operating temperature observed during the test.

1.2.1.2. Full flow dilution system (Figure 13)

A dilution system is described based upon the dilution of the total exhaust using the constant volume sampling (CVS) concept. The total volume of the mixture of exhaust and dilution air must be measured. Either a PDP or a CFV or a SSV system may be used.

For subsequent collection of the particulates, a sample of the dilute exhaust gas is passed to the particulate sampling system (section 1.2.2, Figures 14 and 15). If this is done directly, it is referred to as single dilution. If the sample is diluted once more in the secondary dilution tunnel, it is referred to as double dilution. This is useful, if the filter face temperature requirement cannot be met with single dilution. Although partly a dilution system, the double dilution system is described as a modification of a particulate sampling system in section 1.2.2, (Figure 15), since it shares most of the parts with a typical particulate sampling system.

The gaseous emissions may also be determined in the dilution tunnel of a full flow dilution system. Therefore, the sampling probes for the gaseous components are shown in Figure 13 but do not appear in the description list. The respective requirements are described in section 1.1.1.

Descriptions (Figure 13)

- EP exhaust pipe

The exhaust pipe length from the exit of the engine exhaust manifold, turbocharger outlet or after-treatment device to the dilution tunnel is required to be not more than 10 m. If the system exceeds 4 m in length, then all tubing in excess of 4 m shall be insulated, except for an in-line smoke-meter, if used. The radial thickness of the insulation must be at least 25 mm. The thermal conductivity of the insulating material must have a value no greater than 0,1 W/(m · K) measured at 673 K (400°C). To reduce the thermal inertia of the exhaust pipe a thickness to diameter ratio of 0,015 or less

Status: EU Directives are being published on this site to aid cross referencing from UK legislation. After IP completion day (31 December 2020 11pm) no further amendments will be applied to this version.

is recommended. The use of flexible sections shall be limited to a length to diameter ratio of 12 or less.

Figure 13

Full flow dilution system

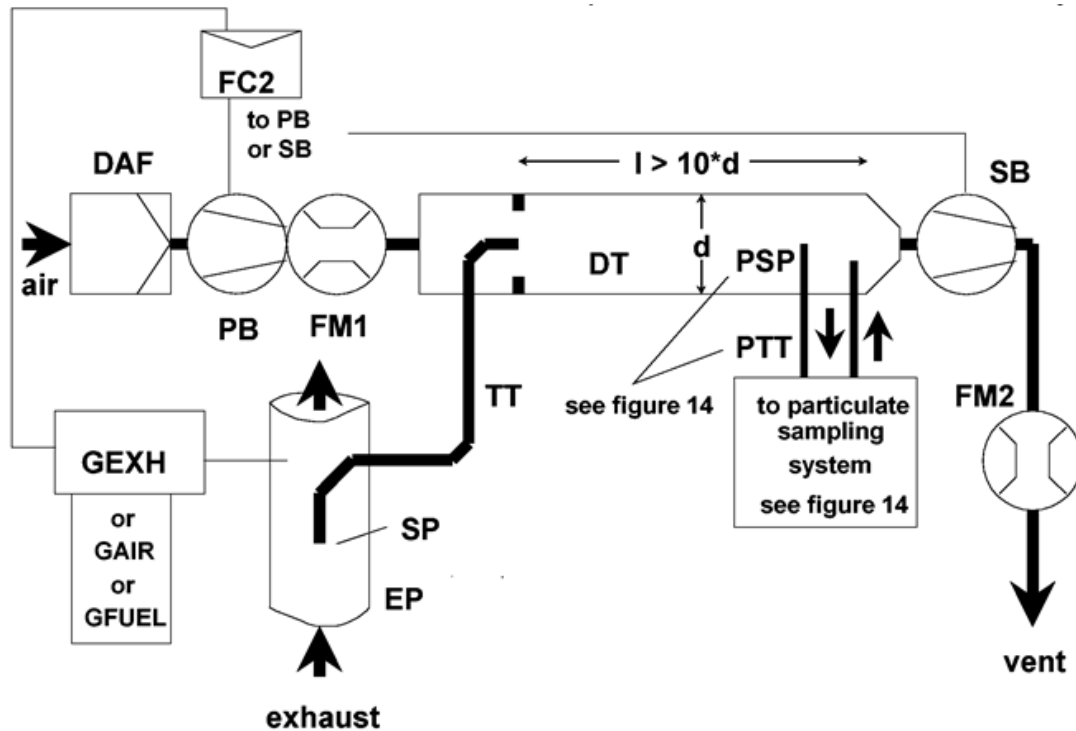

The total amount of raw exhaust gas is mixed in the dilution tunnel DT with the dilution air. The diluted exhaust gas flow rate is measured either with a positive displacement pump PDP or with a critical flow venturi CFV or with a sub-sonic venturi SSV. A heat exchanger FIE or electronic flow compensation EFC may be used for proportional particulate sampling and for flow determination. Since particulate mass determination is based on the total diluted exhaust gas flow, the dilution ratio is not required to be calculated.

— PDP positive displacement pump

The PDP meters total diluted exhaust flow from the number of the pump revolutions and the pump displacement. The exhaust system back pressure must not be artificially lowered by the PDP or dilution air inlet system. Static exhaust back pressure measured with the CVS system operating shall remain within $\pm 1,5$ kPa of the static pressure measured without connection to the CVS at identical engine speed and load.

The gas mixture temperature immediately ahead of the PDP shall be within ± 6 K of the average operating temperature observed during the test, when no flow compensation is used.

Flow compensation can only be used if the temperature at the inlet of the PDP does not exceed 50°C (323 K).

— CFV critical flow venturi

CFV measures total diluted exhaust flow by maintaining the flow at choked conditions (critical flow). Static exhaust backpressure measured with the CFV system operating shall remain within $\pm 1,5$ kPa of the static pressure measured without connection to

the CFV at identical engine speed and load. The gas mixture temperature immediately ahead of the CFV shall be within ± 11 K of the average operating temperature observed during the test, when no flow compensation is used.

— SSV sub-sonic venturi

SSV measures total diluted exhaust flow as a function of inlet pressure, inlet temperature, pressure drop between the SSV inlet and throat. Static exhaust backpressure measured with the SSV system operating shall remain within $\pm 1,5$ kPa of the static pressure measured without connection to the SSV at identical engine speed and load. The gas mixture temperature immediately ahead of the SSV shall be within ± 11 K of the average operating temperature observed during the test, when no flow compensation is used.

— HE heat exchanger (optional if EFC is used)

The heat exchanger shall be of sufficient capacity to maintain the temperature within the limits required above.

— EFC electronic flow compensation (optional if HE is used)

If the temperature at the inlet to either the PDP or CFV or SSV is not kept within the limits stated above, a flow compensation system is required for continuous measurement of the flow rate and control of the proportional sampling in the particulate system. To that purpose, the continuously measured flow rate signals are used to correct the sample flow rate through the particulate filters of the particulate sampling system (Figures 14 and 15), accordingly.

— DT dilution tunnel

The dilution tunnel:

- shall be small enough in diameter to cause turbulent flow (Reynolds number greater than 4000) of sufficient length to cause complete mixing of the exhaust and dilution air. A mixing orifice may be used,
- shall be at least 75 mm in diameter,
- may be insulated.

The engine exhaust shall be directed downstream at the point where it is introduced into the dilution tunnel, and thoroughly mixed.

When using single dilution, a sample from the dilution tunnel is transferred to the particulate sampling system (section 1.2.2, Figure 14). The flow capacity of the PDP or CFV or SSV must be sufficient to maintain the diluted exhaust at a temperature of less than or equal to 325 K (52°C) immediately before the primary particulate filter.

When using double dilution, a sample from the dilution tunnel is transferred to the secondary dilution tunnel where it is further diluted, and then passed through the sampling filters (section 1.2.2, Figure 15). The flow capacity of the PDP or CFV or SSV must be sufficient to maintain the diluted exhaust stream in the DT at a temperature of less than or equal to 464 K (191°C) at the sampling zone. The secondary dilution system must provide sufficient secondary dilution air to maintain the doubly-diluted exhaust stream at a temperature of less than or equal to 325 K (52°C) immediately before the primary particulate filter.

— DAF dilution air filter

It is recommended that the dilution air be filtered and charcoal scrubbed to eliminate background hydrocarbons. The dilution air shall have a temperature of 298 K (25°C) \pm

Status: EU Directives are being published on this site to aid cross referencing from UK legislation. After IP completion day (31 December 2020 11pm) no further amendments will be applied to this version.

5 K. At the manufacturer's request the dilution air shall be sampled according to good engineering practice to determine the background particulate levels, which can then be subtracted from the values measured in the diluted exhaust.

— PSP particulate sampling probe

The probe is the leading section of PTT and

- shall be installed facing upstream at a point where the dilution air and exhaust gas are well mixed, i.e. on the dilution tunnel DT centre-line of the dilution systems approximately 10 tunnel diameters downstream of the point where the exhaust enters the dilution tunnel,
- shall be 12 mm in minimum inside diameter,
- may be heated to no greater than 325 K (52°C) wall temperature by direct heating or by dilution air preheating, provided the air temperature does not exceed 325 K (52°C) prior to the introduction of the exhaust in the dilution tunnel,
- may be insulated.

1.2.2. Particulate sampling system (Figures 14 and 15)

The particulate sampling system is required for collecting the particulates on the particulate filter. In the case of total sampling partial flow dilution, which consists of passing the entire dilute exhaust sample through the filters, dilution (section 1.2.1.1, Figures 7 and 11) and sampling system usually form an integral unit. In the case of fractional sampling partial flow dilution or full flow dilution, which consists of passing through the filters only a portion of the diluted exhaust, the dilution (section 1.2.1.1, Figures 4, 5, 6, 8, 9, 10 and 12 and section 1.2.1.2, Figure 13) and sampling systems usually form different units.

In this Directive, the double dilution system DDS (Figure 15) of a full flow dilution system is considered as a specific modification of a typical particulate sampling system as shown in Figure 14. The double dilution system includes all important parts of the particulate sampling system, like filter holders and sampling pump, and additionally some dilution features, like a dilution air supply and a secondary dilution tunnel.

In order to avoid any impact on the control loops, it is recommended that the sample pump be running throughout the complete test procedure. For the single filter method, a bypass system shall be used for passing the sample through the sampling filters at the desired times. Interference of the switching procedure on the control loops must be minimized.

Descriptions - Figures 14 and 15

— PSP particulate sampling probe (Figures 14 and 15)

The particulate sampling probe shown in the figures is the leading section of the particulate transfer tube PTT. The probe:

- shall be installed facing upstream at a point where the dilution air and exhaust gas are well mixed, i.e. on the dilution tunnel DT centre-line of the dilution systems (section 1.2.1), approximately 10 tunnel diameters downstream of the point where the exhaust enters the dilution tunnel),
- shall be 12 mm in minimum inside diameter,
- may be heated to no greater than 325 K (52°C) wall temperature by direct heating or by dilution air pre-heating, provided the air temperature does not exceed 325 K (52°C) prior to the introduction of the exhaust in the dilution tunnel,
- may be insulated.

Figure 14

Status: EU Directives are being published on this site to aid cross referencing from UK legislation. After IP completion day (31 December 2020 11pm) no further amendments will be applied to this version.

Particulate sampling system

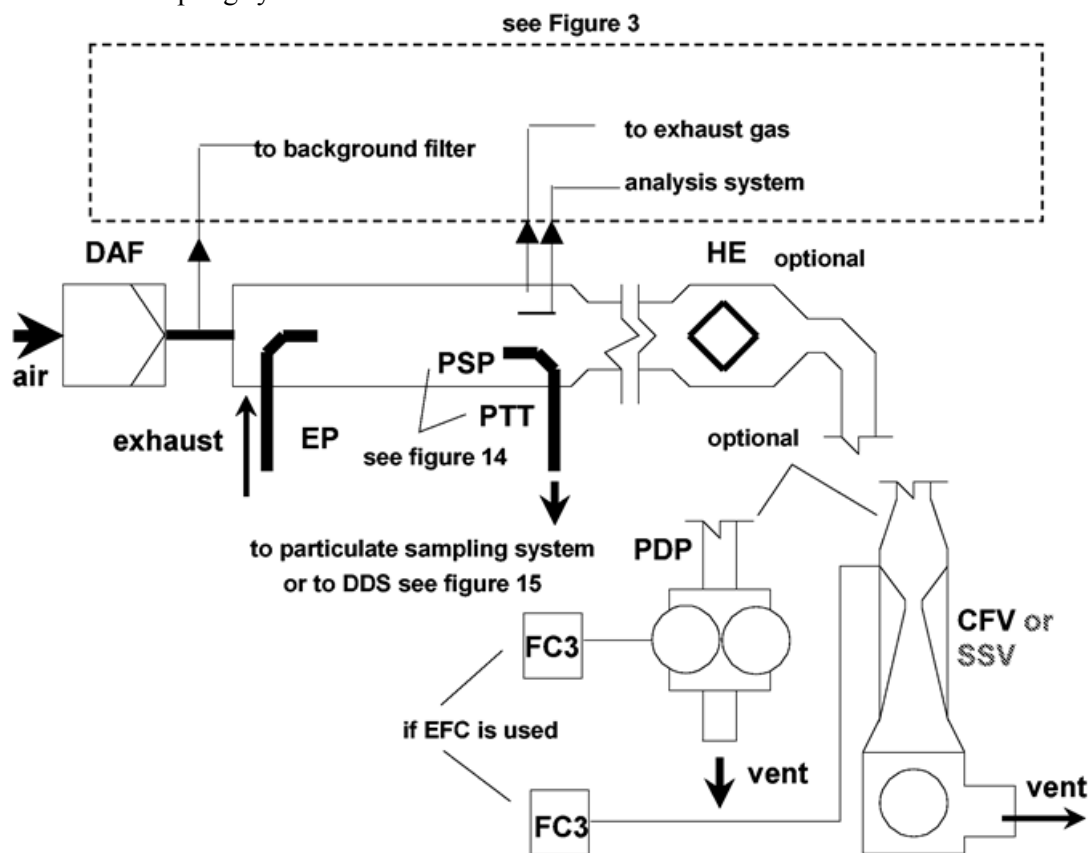

A sample of the diluted exhaust gas is taken from the dilution tunnel DT of a partial flow or full flow dilution system through the particulate sampling probe PSP and the particulate transfer tube PTT by means of the sampling pump P. The sample is passed through the filter holder(s) FH that contain the particulate sampling filters. The sample flow rate is controlled by the flow controller FC3. If electronic flow compensation EFC (Figure 13) is used, the diluted exhaust gas flow is used as command signal for FC3.
Figure 15

Status: EU Directives are being published on this site to aid cross referencing from UK legislation. After IP completion day (31 December 2020 11pm) no further amendments will be applied to this version.

Dilution system (full flow system only)

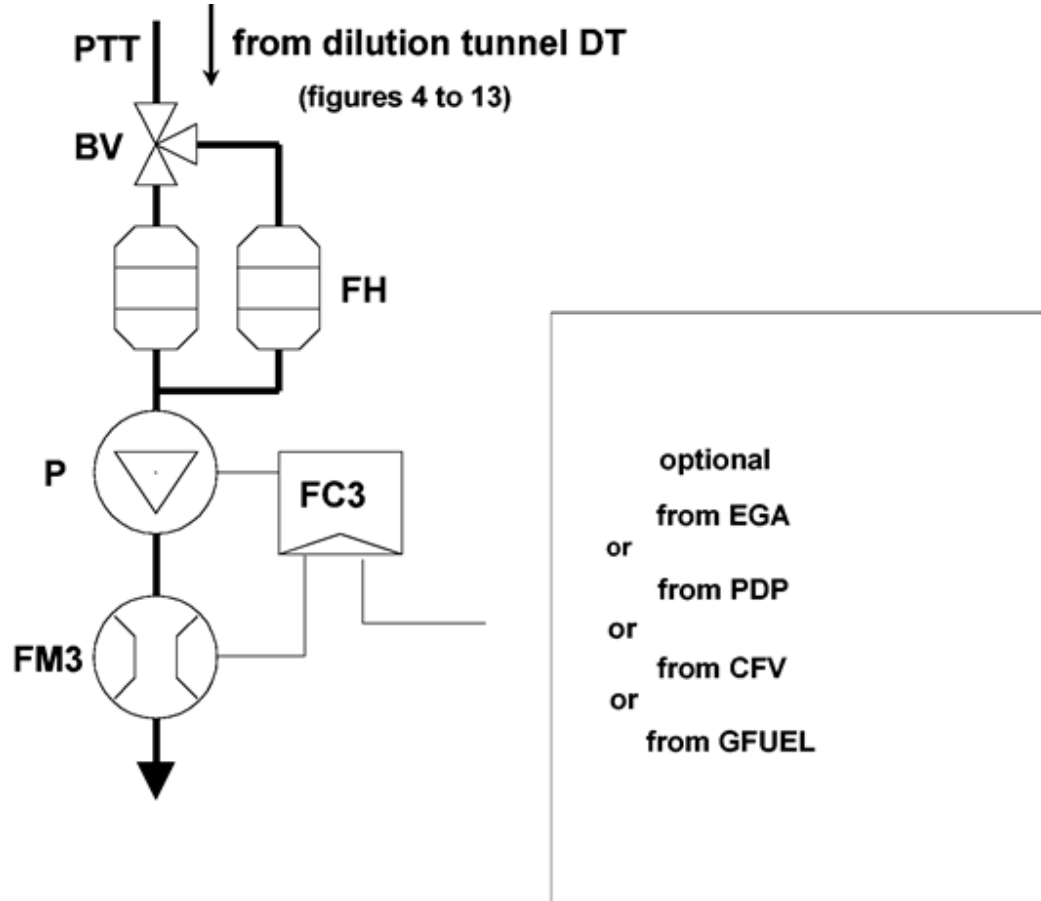

A sample of the diluted exhaust gas is transferred from the dilution tunnel DT of a full flow dilution system through the particulate sampling probe PSP and the particulate transfer tube PTT to the secondary dilution tunnel SDT, where it is diluted once more. The sample is then passed through the filter holder(s) FH that contain the particulate sampling filters. The dilution air flow rate is usually constant whereas the sample flow rate is controlled by the flow controller FC3. If electronic flow compensation EFC (Figure 13) is used, the total diluted exhaust gas flow is used as command signal for FC3.

— PTT particulate transfer tube (Figures 14 and 15)

The particulate transfer tube must not exceed 1 020 mm in length, and must be minimised in length whenever possible.

The dimensions are valid for:

- the partial flow dilution fractional sampling type and the full flow single dilution system from the probe tip to the filter holder,
- the partial flow dilution total sampling type from the end of the dilution tunnel to the filter holder,
- the full flow double dilution system from the probe tip to the secondary dilution tunnel.

The transfer tube:

- may be heated to no greater than 325 K (52°C) wall temperature by direct heating or by dilution air preheating, provided the air temperature does not exceed 325 K (52°C) prior to the introduction of the exhaust in the dilution tunnel,
- may be insulated.
- SDT secondary dilution tunnel (Figure 15)

The secondary dilution tunnel should have a minimum diameter of 75 mm and should be sufficient length so as to provide a residence time of at least 0,25 seconds for the doubly-diluted sample. The primary filter holder, FH, shall be located within 300 mm of the exit of the SDT. The secondary dilution tunnel:

- may be heated to no greater than 325 K (52°C) wall temperature by direct heating or by dilution air preheating, provided the air temperature does not exceed 325 K (52°C) prior to the introduction of the exhaust in the dilution tunnel,
- may be insulated.
- FH filter holder(s) (Figures 14 and 15)

For primary and back-up filters one filter housing or separate filter housings may be used. The requirements of Annex III, Appendix 1, section 1.5.1.3 have to be met.

The filter holder(s):

- may be heated to no greater than 325 K (52°C) wall temperature by direct heating or by dilution air preheating, provided the air temperature does not exceed 325 K (52°C),
- may be insulated.
- P sampling pump (Figures 14 and 15)

The particulate sampling pump shall be located sufficiently distant from the tunnel so that the inlet gas temperature is maintained constant (± 3 K), if flow correction by FC3 is not used.

- DP dilution air pump (Figure 15) (full flow double dilution only)

The dilution air pump shall be located so that the secondary dilution air is supplied at a temperature of 298 K (25°C) ± 5 K.

- FC3 flow controller (Figures 14 and 15)

A flow controller shall be used to compensate the particulate sample flow rate for temperature and backpressure variations in the sample path, if no other means are available. The flow controller is required if electronic flow compensation EFC (Figure 13) is used.

- FM3 flow measurement device (Figures 14 and 15) (particulate sample flow)

The gas meter or flow instrumentation shall be located sufficiently distant from the sample pump so that the inlet gas temperature remains constant (± 3 K), if flow correction by FC3 is not used.

- FM4 flow measurement device (Figure 15) (dilution air, full flow double dilution only)

The gas meter or flow instrumentation shall be located so that the inlet gas temperature remains at 298 K (25 °C) ± 5 K.

- BV ball valve (optional)

Status: EU Directives are being published on this site to aid cross referencing from UK legislation. After IP completion day (31 December 2020 11pm) no further amendments will be applied to this version.

The ball valve shall have a diameter not less than the inside diameter of the sampling tube and a switching time of less than 0,5 seconds.

NOTE: If the ambient temperature in the vicinity of PSP, PTT, SDT, and FH is below 239 K (20°C), precautions should be taken to avoid particle losses onto the cool wall of these parts. Therefore, heating and/or insulating these parts within the limits given in the respective descriptions is recommended. It is also recommended that the filter face temperature during sampling be not below 293 K (20°C).

At high engine loads, the above parts may be cooled by a non-aggressive means such as a circulating fan, as long as the temperature of the cooling medium is not below 293 K (20°C).

ANNEX III

"Annex XIII PROVISIONS FOR ENGINES PLACED ON THE MARKET UNDER A "FLEXIBLE SCHEME"

On the request of an equipment manufacturer (OEM), and permission being granted by an approval authority, an engine manufacturer may during the period between two successive stages of limit values place a limited number of engines on the market that only comply with the previous stage of emission limit values in accordance with the following provisions:

1. ACTIONS BY THE ENGINE MANUFACTURER AND THE OEM 1.1.

An OEM that wishes to make use of the flexibility scheme shall request permission from any approval authority to purchase from his engine suppliers, in the period between two emissions stages, the quantities of engines described in sections 1.2 and 1.3, that do not comply with the current emission limit values, but are approved to the nearest previous stage of emission limits.

1.2.

The number of engines placed on the market under a flexibility scheme shall, in each engine category, not exceed 20% of the OEM's annual sales of equipment with engines in that engine category (calculated as the average of the latest 5 years sales on the EU market). Where an OEM has marketed equipment in the EU for a period of less than 5 years the average will be calculated based on the period for which the OEM has marketed equipment in the EU.

1.3. As an optional alternative option to section 1.2, the OEM may seek permission for his engine suppliers to place on the market a fixed number of engines under the flexibility scheme. The number of engines in each engine category shall not exceed the following values:

Engine Category	Number of Engines
19-37kW	200
37-75kW	150
75-130kW	100
130-560kW	50

Status: EU Directives are being published on this site to aid cross referencing from UK legislation. After IP completion day (31 December 2020 11pm) no further amendments will be applied to this version.

1.4. The OEM shall include in his application to an approval authority the following information:

- (a) a sample of the labels to be affixed to each piece of non-road mobile machinery in which an engine placed on the market under the flexibility scheme will be installed. The labels shall bear the following text: "MACHINE NO ... (sequence of machines) OF ... (total number of machines in respective power band) WITH ENGINE No ... WITH TYPE APPROVAL (Dir. 97/68/EC) No ..."; and
- (b) a sample of the supplementary label to be affixed on the engine bearing the text referred to in section 2.2 of this Annex.

1.5.

The OEM shall notify the approval authorities of each Member State of the use of the flexibility scheme.

1.6.

The OEM shall provide the approval authority with any information connected with the implementation of the flexibility scheme that the approval authority may request as necessary for the decision.

1.7.

The OEM shall file a report every six months to the approval authorities of each Member State on the implementation of the flexibility schemes he is using. The report shall include cumulative data on the number of engines and NRMM placed on the market under the flexibility scheme, engine and NRMM serial numbers, and the Member States where the NRMM have been placed on the market. This procedure shall be continued as long as a flexibility scheme is still in progress.

2. ACTIONS BY THE ENGINE MANUFACTURER 2.1.

An engine manufacturer may place on the market engines under a flexible scheme covered by an approval in accordance with Section 1 of this Annex.

2.2.

The engine manufacturer must put a label on those engines with the following text: "Engine placed on the market under the flexibility scheme".

3. ACTIONS BY THE APPROVAL AUTHORITY 3.1.

The approval authority shall evaluate the content of the flexibility scheme request and the enclosed documents. As a consequence it will inform the OEM of its decision as to whether or not to allow use of the flexibility scheme.

ANNEX IV

The following Annexes shall be added:

Annex XIV	CCNR stage ICCNR Protocol 19, Resolution of the Central Commission for the Navigation of the Rhine of 11 May 2000 $PN(kW)CO(g/kWh)HC(g/kWh)NO_x(g/kWh)PT(g/kWh)$ $37 \leq PN < 756,51,39,20,8575 \leq PN < 1305,01,39,20,70P \geq 1305,01,3n$ $\geq 2800 \text{ tr/min} = 9.2500 \leq n < 2800 \text{ tr/min} = 45 \times n (-0.2)0,54$
--------------	--

Status: EU Directives are being published on this site to aid cross referencing from UK legislation. After IP completion day (31 December 2020 11pm) no further amendments will be applied to this version.

Annex XV CCNR stage IICNR Protocol 21, Resolution of the Central Commission for the Navigation of the Rhine of 31 May 2001. PN(kW)CO(g/kWh)HC(g/kWh)NOx(g/kWh)PT(g/kWh) $18 \leq \text{PN} < 375,51,58,00,837 \leq \text{PN} < 755,01,37,00,475 \leq \text{PN} < 1305,01,06,00,3130 \leq \text{PN} < 5603,51,06,00,2 \text{PN} \geq 5603,51,0n \geq 3150 \text{ min}^{-1} = 6,0343 \leq n < 3150 \text{ min}^{-1} = 45 \times n(-0,2) - 3n < 343 \text{ mm}^{-1} = 11,00,2$

Status: EU Directives are being published on this site to aid cross referencing from UK legislation. After IP completion day (31 December 2020 11pm) no further amendments will be applied to this version.

- (1) OJ C
- (2) OJ C 220, 16.9.2003, p. 16.
- (3) Opinion of the European Parliament of 21 October 2003 (not yet published in the Official Journal). Council Decision of 30 March 2004 (not yet published in the Official Journal).
- (4) OJ L 59, 27.2.1998, p. 1. Directive as last amended by Directive 2002/88/EC (OJ L 35, 11.2.2003, p. 28).
- (5) OJ L 164, 30.6.1994, p. 15. Directive as last amended by Regulation (EC) No 1882/2003 (OJ L 284, 31.10.2003, p. 1)."
- (6) OJ L 301, 28.10.1982, p. 1. Directive as amended by the 2003 Act of Accession."
- (7) Date of entry into force of this Directive"
- (8) 12 months after the entry into force of this Directive.
- (9) 12 months after the entry into force of this Directive.
- (10) Note 1 shall be amended as follows: Identical with C1 cycle as described in Paragraph 8.3.1.1 of the ISO8178-4: 2002(E) standard.
- (11) Note 2 shall be amended as follows: Identical with D2 cycle as described in Paragraph 8.4.1 of the ISO8178-4: 2002(E) standard.
- (12) Constant-speed auxiliary engines must be certified to the ISO D2 duty cycle, i.e. the 5-mode steady-state cycle specified in Section 3.7.1.2., while variable-speed auxiliary engines must be certified to the ISO C1 duty cycle, i.e. the 8-mode steady-state cycle specified in Section 3.7.1.1.
- (13) Identical with E3 cycle as described in Sections 8.5.1, 8.5.2 and 8.5.3 of the ISO8178-4: 2002(E) standard. The four modes lie on an average propeller curve based on in-use measurements.
- (14) Identical with E2 cycle as described in Sections 8.5.1, 8.5.2 and 8.5.3 of the ISO8178-4: 2002(E) standard.
- (15) Identical with F cycle of ISO 8178-4: 2002 (E) standard."
- (16) The calibration procedure is common for both NRSC and NRTC tests, with the exception of the requirements specified in Sections 1.11 and 2.6.
- (17) In the case of NO_x, the NO_x concentration (NO_xconc or NO_xconc_c) has to be multiplied by K_{HNO_x} (humidity correction factor for NO_x quoted in section 1.3.3) as follows: K_{HNO_x} x conc or K_{HNO_x} x conc_c
- (18) The particulate mass flow rate PT_{mass} has to be multiplied by K_p (humidity correction factor for particulates quoted in section 1.4.1).
- (19) Figures 4 to 12 show many types of partial flow dilution systems, which normally can be used for the steady-state test (NRSC). But, because of very severe constraints of the transient tests, only those partial flow dilution systems (Figures 4 to 12) able to fulfill all the requirements quoted in the section "Partial flow dilution system specifications" of Annex III, Appendix 1, Section 2.4, are accepted for the transient test (NRTC).