

Directive 2000/14/EC of the European Parliament and of the Council of 8 May 2000 on the approximation of the laws of the Member States relating to the noise emission in the environment by equipment for use outdoors

Status: EU Directives are being published on this site to aid cross referencing from UK legislation. After IP completion day (31 December 2020 11pm) no further amendments will be applied to this version.

ANNEX III

METHOD OF MEASUREMENT OF AIRBORNE NOISE EMITTED BY EQUIPMENT FOR USE OUTDOORS

PART B

NOISE TEST CODES FOR SPECIFIC EQUIPMENT

28. HYDRAULIC HAMMERS

Basic noise emission standard

EN ISO 3744:1995

Measurement surface/number of microphone positions/measuring distance

Hemisphere/six microphone positions according to Part A, item 5/r = 10 m

Operating conditions during tests

Mounting of the equipment

For the test the hammer is attached to a carrier and a special test block structure shall be used. Figure 28.1 gives the characteristics of this structure and Figure 28.2 shows the position of the carrier

Carrier

The carrier for the test hammer shall meet the requirements of the test hammer's technical specifications especially in weight range, hydraulic output power, supply oil flow and return line back pressure

Mounting

Mechanical mounting as well as connections (hoses, pipes ...) must correspond to specifications given in the hammer's technical data. All significant noise caused by pipes and various mechanical components needed for installation, ought to be eliminated. All component connections have to be well tightened

Hammer stability and static hold force

The hammer shall be firmly held down by the carrier in order to give the same stability as that existing under normal operating conditions. The hammer must be operated in an upright position

Tool

A blunt tool shall be used in the measurements. The length of the tool must meet the requirements given in Figure 28.1 (test block)

Test under load

Hydraulic input power and oil flow

Operating conditions of the hydraulic hammer shall be appropriately adjusted, measured and reported along with the corresponding technical specification values. The hammer under test must be used in such way that 90 % or more of the maximum hydraulic input power and oil flow of the hammer can be reached

Care shall be taken that the total uncertainty of the measurement chains of p_s and Q is kept within ± 5 %. This assures the hydraulic input power determination within ± 10 % accuracy. Assuming linear correlation between hydraulic input power and emitted sound power this would mean variation of less than $\pm 0,4$ dB in the determination of the sound power level

Adjustable components having effect on the hammer power

Pre-settings of all accumulators, pressure central valves and other possible adjustable components must meet the values given in technical data. If more than one fixed impact rate is optional, measurements have to be made using all settings. Minimum and maximum values are presented

Quantities to be measured

Status: EU Directives are being published on this site to aid cross referencing from UK legislation. After IP completion day (31 December 2020 11pm) no further amendments will be applied to this version.

p_s	The mean value of the hydraulic supply line pressure during the hammer's operation including at least 10 blows
Q	The mean value of the breaker inlet oil flow measured simultaneously with p_s
T	The oil temperature must lie between + 40/ + 60 °C during measurements. The temperature of the hydraulic breaker body must have been stabilised to normal operating temperature before starting the measurements
P_a	The prefill gas pressures of all accumulators must be measured in static situation (breaker not operating) at stable ambient temperature of + 15/ + 25 °C. The measured ambient temperature shall be recorded with the measured accumulator prefill gas pressure

Parameters to be evaluated from the measured operating parameters:

P_{IN} Hydraulic input power of the breaker $P_{IN} = p_s \cdot Q$

Hydraulic supply line pressure measurement, p_s

- p_s must be measured as close to the breaker IN-port as possible
- p_s shall be measured with a pressure gauge (minimum diameter: 100 mm; accuracy class $\pm 1,0$ % FSO)

Breaker inlet oil flow, Q

- Q must be measured from the supply pressure line as close to the breaker IN-port as possible
- Q must be measured with an electric flowmeter (accuracy class $\pm 2,5$ % of the flow reading)

Measuring point of the oil temperature, T

- T must be measured from the oil tank of the carrier or from the hydraulic line connected to hammer. Measuring point shall be specified in the report
- accuracy of the temperature reading must lie within ± 2 °C of the actual value

Period of observation/determination of resulting sound power level

The period of observation shall be at least 15 seconds

The measurements are repeated three times, or more if necessary. The final result is calculated as the arithmetic mean of the two highest values that do not differ by more than 1dB

Figure

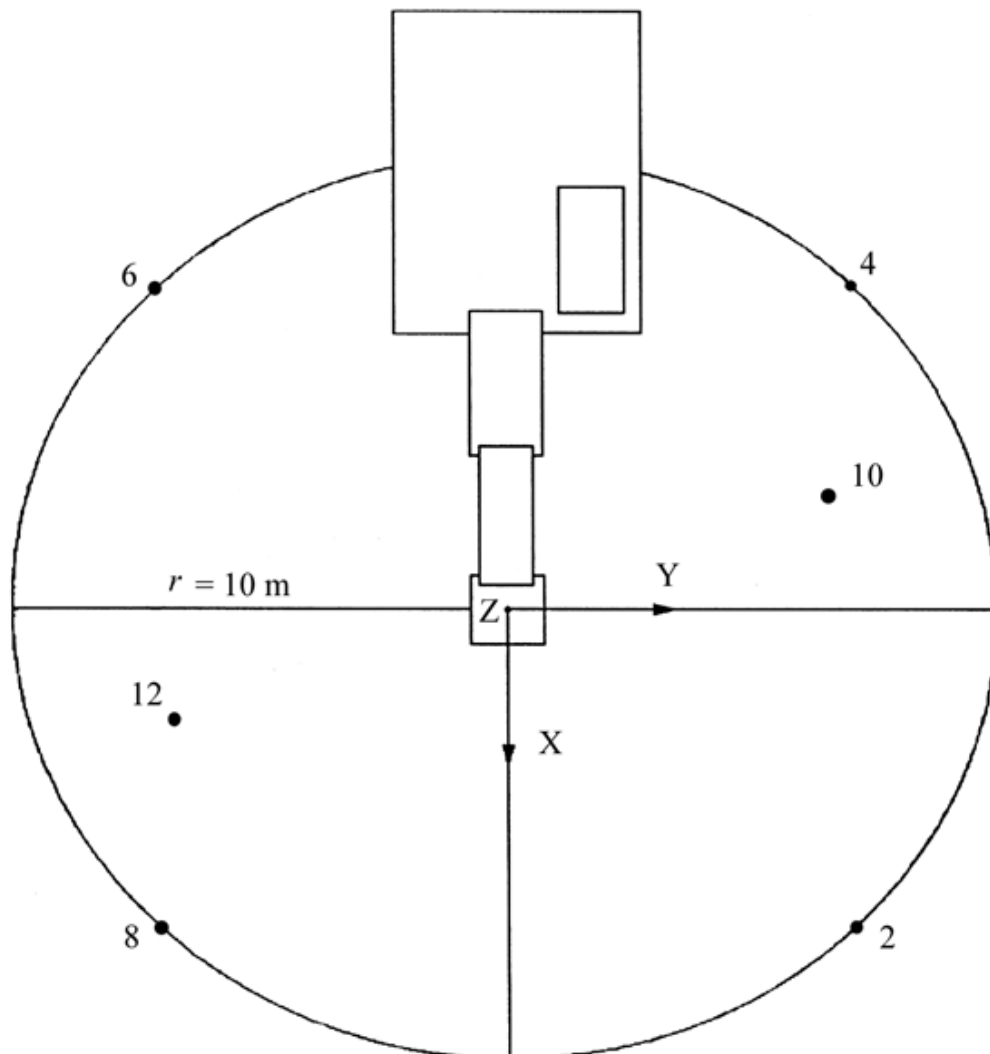

28.1

Status: EU Directives are being published on this site to aid cross referencing from UK legislation. After IP completion day (31 December 2020 11pm) no further amendments will be applied to this version.

Figure

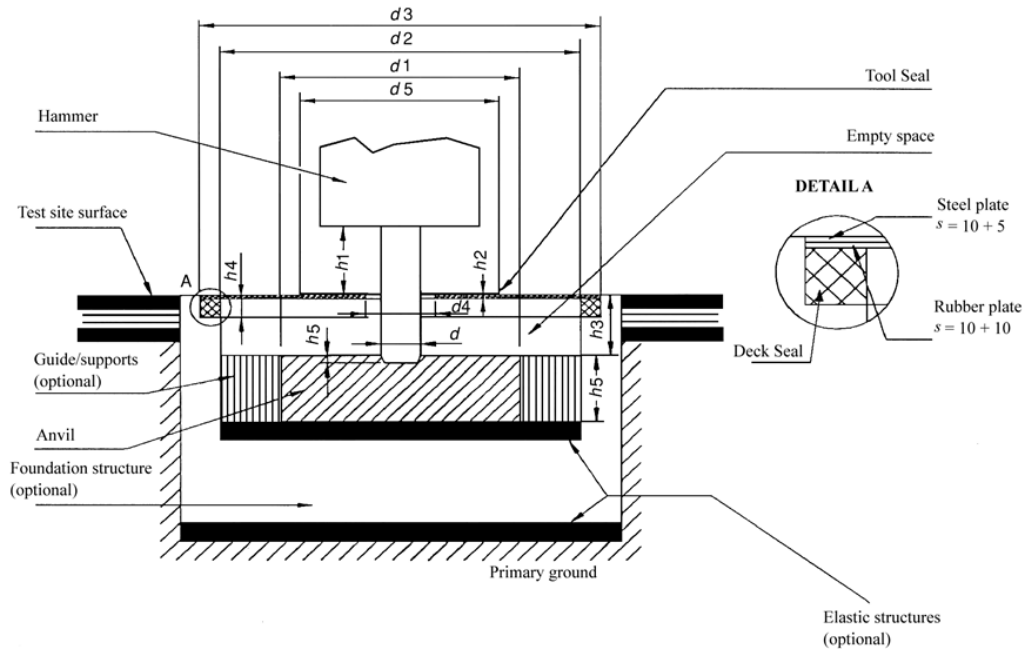

28.2

Definitions

d	Tool diameter (mm)
d_1	Anvil diameter, $1\ 200 \pm 100$ mm
d_2	Inner diameter of the anvil support structure, $\leq 1\ 800$ mm
d_3	Diameter of the test block deck, $\leq 2\ 200$ mm
d_4	Diameter of the tool opening in the deck, ≤ 350 mm
d_5	Diameter of the tool seal, $\leq 1\ 000$ mm
h_1	Visible tool length between the lowest part of the housing and tool seal upper surface (mm), $h_1 = d \pm d/2$
h_2	Tool seal thickness above the deck, ≤ 20 mm (if the tool seal is located below the deck, its thickness is not limited; it may be made of foam rubber)
h_3	Distance between deck upper surface and anvil upper surface, 250 ± 50 mm
h_4	Isolating foam rubber deck seal thickness, ≤ 30 mm
h_5	Anvil thickness, 350 ± 50 mm

Status: EU Directives are being published on this site to aid cross referencing from UK legislation. After IP completion day (31 December 2020 11pm) no further amendments will be applied to this version.

h_6	Tool penetration, ≤ 50 mm
-------	--------------------------------

If the quadratic shape of the test block structure is used, the maximum length dimension equals $0,89 \times$ corresponding diameter

The empty space between the deck and the anvil can be filled with elastic foam rubber or other absorption material, density < 220 kg/m³