

II

(Acts whose publication is not obligatory)

COMMISSION

FIRST COMMISSION DIRECTIVE

of 6 October 1987

laying down Community methods of sampling for chemical analysis for the monitoring of preserved milk products

(87/524/EEC)

THE COMMISSION OF THE EUROPEAN COMMUNITIES,

Having regard to the Treaty establishing the European Economic Community,

Having regard to Council Directive 85/591/EEC of 20 December 1985 concerning the introduction of Community methods of sampling and analysis for the monitoring of foodstuffs intended for human consumption⁽¹⁾, and in particular Article 1 (1) thereof,

Whereas Council Directive 76/118/EEC of 18 December 1975 on the approximation of the laws of the Member States relating to certain partly or wholly dehydrated preserved milk for human consumption⁽²⁾, as last amended by the Act of Accession of Spain and Portugal, lays down Community rules governing the composition, use of reserved designations, conditions of manufacture and labelling of the products in question;

Whereas, pursuant to Article 1 (1) of Directive 85/591/EEC, samples of such products must be taken in accordance with Community methods for the purpose of determining their composition, conditions of manufacture, packaging or labelling;

Whereas it is desirable to adopt an initial series of methods of sampling for chemical analysis in respect of which studies have been completed;

Whereas the measures provided for in this Directive are in accordance with the opinion of the Standing Committee for Foodstuffs,

HAS ADOPTED THIS DIRECTIVE:

Article 1

Member States shall take all measures necessary to ensure that the taking of samples as referred to in the Annex is carried out in accordance with the methods described therein.

Article 2

Member States shall take all measures necessary to comply with this Directive by 6 April 1989 at the latest. They shall forthwith inform the Commission thereof.

Article 3

This Directive is addressed to the Member States.

Done at Brussels, 6 October 1987.

For the Commission

COCKFIELD

Vice-President

⁽¹⁾ OJ No L 372, 31. 12. 1985, p. 50.

⁽²⁾ OJ No L 24, 30. 1. 1976, p. 49.

ANNEX

METHODS OF SAMPLING RELATED TO THE CONTROL OF CHEMICAL ANALYSIS OF CERTAIN PARTLY OR WHOLLY DEHYDRATED PRESERVED MILK PRODUCTS**I. GENERAL PROVISIONS****1. Administrative instructions****1.1. Personnel**

Sampling shall be performed by an authorized qualified person as specified in the Member State's regulations.

1.2. Sealing and labelling of samples

Each sample taken for official use shall be sealed at the place of sampling and identified following the Member State's regulations.

1.3. Replicate samples

At least two equivalent samples shall be simultaneously prepared for analysis. Under reservation of Community legislation to be defined, the procedure and number of samples to be taken depending upon the appropriate national legislation for each Member State.

The samples shall be dispatched to the laboratory as soon as possible after sampling.

1.4. Report

Samples shall be accompanied by a report, which will be established in accordance with the Member State's legislation.

2. Sampling Equipment*Specifications*

All sampling equipment shall be made of suitable material of adequate strength, which does not bring about a change in the sample which may affect any result of the subsequent examination and should not cause any change in the samples while sampling is being carried out. The use of stainless steel is recommended.

All surfaces shall be smooth and free from crevices and all corners shall be rounded. Sampling equipment shall comply with the requirements laid down with respect to each product to be sampled.

3. Sampling containers*Specifications*

Sample containers and closures shall be of materials and construction which adequately protect the sample and which do not bring about in the sample a change which may affect any result of the subsequent analysis or examination. Materials which are appropriate include glass, some metals and some plastics. The containers shall preferably be opaque. If transparent or translucent the container with contents shall be stored in a dark place.

Containers and closures shall be clean and dry. The shape and capacity of the container shall be appropriate to the requirements laid down for the product to be sampled.

Single service plastic containers, containers made from plastic, laminates including an aluminium foil or suitable plastic bags, with appropriate methods of closure, may be used.

Containers other than plastic bags shall be securely closed either by means of a suitable stopper or by a screw-cap of metal or plastic material having, if necessary, an air-tight plastic liner. Any stopper or liner used should be insoluble, non-absorbant and greaseproof, and will not influence the odour, flavour, properties or composition of the sample.

Stoppers shall be made of, or covered with, non-absorbant odourless materials.

4. Sampling technique

The sample container shall be closed immediately after sampling.

5. Storage of samples

The recommended storage temperatures of the samples of the various products shall not exceed 25 °C. Storage time and temperature must be considered together and not separately.

6. Transport of samples

Samples shall be brought to the laboratory responsible for the tests as soon as possible (preferably within 24 hours of sample taking).

During transit, precautions shall be taken to prevent exposure to contaminating odours, to direct sunlight and to temperatures greater than 25 °C.

II. METHOD 1: SAMPLING OF PARTLY DEHYDRATED MILKS**1. Scope and field of application**

- unsweetened condensed high-fat milk,
- unsweetened condensed milk,
- unsweetened condensed partly skimmed milk,
- unsweetened condensed skimmed milk,
- sweetened condensed milk,
- sweetened condensed skimmed milk,
- sweetened condensed partly skimmed milk.

2. Equipment**2.1. General**

See Section 2 of the General Provisions.

2.2. Plungers and agitators

Plungers or agitators, for mixing liquids in bulk, shall be of sufficient area to produce adequate disturbance of the product without developing rancid flavour. In view of the different shapes and sizes of containers, no specific design of plunger can be recommended for all purposes, but plungers shall be designed in such a way as to avoid scratching the inner surface of the product containers during agitation.

Suitable material has been described in Section 2 of the General Provisions.

A form of plunger recommended as being suitable for the mixing of liquids in buckets or in cans has the following dimensions (Fig. 1): a disc 150 millimetres in diameter, perforated with six holes each of 12,5 millimetres in diameter on a circle 100 millimetres in diameter, the disc being fixed centrally to a metallic rod, the other end of which forms a loop handle. The length of the rod, including the handle, shall be approximately 1 metre.

A suitable plunger for use for small tanks, has the following approximate dimensions (Fig. 2): a rod not less than 2 metres in length, fitted with a disc 300 millimetres in diameter perforated with 12 holes each 30 millimetres in diameter on a circle 230 millimetres in diameter.

For mixing the contents of large vessels, mechanical agitation or agitation by clean compressed air is advisable. Minimal air pressure and volume shall be used to prevent rancid flavour development.

Note: Wherever 'clean compressed air' is required by this guide, it is necessary to use compressed air from which all contaminants (including oil, water and dust) have been excluded.

2.3. Stirrer

Broad bladed, of sufficient depth to reach the bottom of the product container, and which preferably has one edge shaped to the contour of the container (see Fig. 3).

2.4. Dippers

A dipper of suitable size and shape for collecting the sample is illustrated in Fig. 4. The dipper shall be fitted with a solid handle at least 150 millimetres in length. The capacity of the dipper shall be not less than 50 millilitres. It is an advantage for the handle to be bent over. The tapered form of the cup permits nesting of the dippers.

Alternatively, a dipper of similar capacity may be used, but it should have parallel sides graduated into five equal sections for assistance in sampling proportionately consignments held in more than one container.

2.5. Rod

Round, about 1 metre long and 35 millimetres in diameter.

2.6. Container

For sub-sampling capacity of 5 litres, wide mouthed.

2.7. Spoon or spatula

Broad bladed.

2.8. *Sample containers*

See Section 3 of General Provisions.

3. **Procedure**

3.1. *Sampling of unsweetened partly dehydrated milks*

A sample of not less than 200 grams shall be taken.

- 3.1.1. The product shall be thoroughly mixed by plunging or stirring, or by mechanical agitation, or by pouring from one container to another, or by the use of clean compressed air (see note 2.2), until sufficient homogeneity is obtained.

Take the sample immediately after mixing by means of a dipper. If obtaining sufficient homogeneity presents difficulties, samples shall be taken from different portions of the product container to a total of not less than 200 grams. (It shall be noted if the sample is a mixture of sub-samples on the sample label and in the accompanying report).

- 3.1.2. Sampling products packed in small retail containers

The intact and unopened container may constitute the sample. One or more containers with the same batch or code number shall be taken to make up a sample of not less than 200 grams.

3.2. *Sampling of sweetened partly dehydrated milk*

3.2.1. General

The sampling of bulk containers of sweetened partly dehydrated milk may be a matter of extreme difficulty, particularly when the product is not homogeneous and is highly viscous. Problems of sampling may arise through the presence of large crystals of sucrose or lactose, or through precipitation of various salts which may occur throughout the body of the product or adhere to the walls, or through the presence of lumpy matter. Such conditions will become apparent when a sampling rod is introduced into the product container and is withdrawn after exploring as large an area of contact as possible. Provided the size of sugar crystals is not larger than 6 millimetres, difficulties in sampling should not be experienced from this cause. When the product is not homogeneous, this fact shall be noted on the sample label of the accompanying report. Since sweetened condensed milk is frequently stored at atmospheric temperature, it is recommended that in order to obtain a representative sample the contents shall be brought to a temperature of not less than 20 °C.

3.2.2. Procedure

A sample of not less than 200 grams shall be taken.

— Open containers

One end of the container, previously thoroughly cleaned and dried to prevent foreign matter falling into the bulk during the opening process, shall be removed. The contents shall be mixed by using a stirrer (see Fig. 3). The blade shall be scraped around the sides and bottom of the container to remove any adhering product. The contents shall be thoroughly mixed by a combination of rotary and vertical movements, with the stirrer inclined diagonally, taking care to avoid incorporation of air in the sample. The stirrer shall be withdrawn and the condensed milk adhering to it shall be transferred into the 5-litre (2.6) container by means of a spatula or spoon. The mixing and withdrawal shall be repeated until 2 to 3 litres have been collected. This shall be mixed until homogeneous and a sample of not less than 200 grams shall be taken.

— Enclosed drums with bungs at the end, or at the side

For the reasons described in 3.2.1, sampling through the bung hole is suitable only with condensed milk which flows readily and is of uniform consistency. The contents shall be mixed by inserting a rod through the bung hole, and after exploring and stirring as far as possible in all directions, the rod shall be withdrawn and a sample shall be prepared as described in 3.2.1. Alternatively, the contents may be allowed to run into a suitable container, care being taken that as much of the contents as possible be recovered from the drum. After stirring with a stirrer the sample shall be collected as described in 3.2.1.

3.2.3. Sampling products packed in small retail containers

The intact and unopened container may constitute the sample. One or more containers with the same batch or code number shall be taken to make up a sample of not less than 200 grams.

3.3. *Preservation, storage and transport of sample*

See Sections 5 and 6 of the General Provisions.

III. METHOD 2: SAMPLING OF POWDERED PRESERVED MILK PRODUCTS

1. **Scope and field of application**

This method describes the sampling for chemical analysis of:

- dried whole milk or whole milk powder,
- dried skimmed milk or skimmed milk powder,
- dried partly skimmed milk or partly skimmed milk powder,
- dried high-fat milk or high-fat milk powder.

2. **Equipment**

See Section 2 of the General Provisions.

2.1. *Borers of sufficient length to reach the bottom of the product container*

Borers conforming to the description given in Part IV are appropriate.

2.2. *Scoop, spoon or broad-bladed spatula*2.3. *Sample containers*

See Section 3 of the General Provisions.

3. **Procedure**3.1. *General*

Care shall be taken to minimize the uptake of atmospheric moisture by the content of the product container or in the period prior to sampling for analysis. The product container shall be securely reclosed after sampling.

3.2. *Sampling*

A sample of not less than 200 grams shall be taken. The clean and dry borer shall be passed through the product, if necessary with the container inclined or laid on its side. The slit shall be oriented downward and an even rate of penetration used. When the borer reaches the bottom of the container it shall be rotated through 180°, withdrawn and the contents discharged into the sample container. One or more borers shall be taken to make a sample of not less than 200 grams. The sample container shall be closed immediately after sampling is complete.

3.2.1. *Sampling products packed in small retail packages*

The intact and unopened package may constitute the sample. One or more containers with the same batch or code number shall be taken to make up a sample of not less than 200 grams.

Note: When products are described as 'instant', a whole unopened package must constitute the sample.

3.3. *Preservation, stockage and transport of sample*

See Sections 5 and 6 of the General Provisions.

IV. BORERS FOR THE SAMPLING OF POWDERED PRESERVED MILK IN BULK

1. **Types of borer**

Type A: long

Type B: short

(see Fig. 5).

2. **Materials**

Blade and stem shall be made of polished metal, preferably stainless steel.

The grip of the long type should preferably be made of stainless steel.

The short type borer shall have a detachable grip of wood or plastic, fitted with a bayonet catch in the blade.

3. **Construction**3.1. *Shape, material and finish shall be such as to permit the borer to be easily cleaned.*3.2. *The protruding edge of the blade of type A shall be sufficiently sharp to serve as a scraper.*3.3. *The point of the blade shall be sufficiently sharp to facilitate sampling.*

4. **Principal dimensions**

The borers shall conform to the dimensions (subject to a tolerance of 10 %) given in the table hereafter :

(Dimensions in mm)

| | Type A long | Type B short |
|---|----------------|-----------------|
| Length of blade | 800 | 400 |
| Thickness of metal of blade | 1 to 2 | 1 to 2 |
| Inner diameter of blade at point | 18 | 32 |
| Inner diameter of blade at grip or stem | 22 | 28 |
| Slit width at point | 4 | 20 |
| Slit width at grip or stem | 14 | 14 |

5. **Note on use of borers**

- 5.1. With less free-flowing powders, the borers can be inserted vertically. Type A borers are then filled completely by turning and can be withdrawn vertically. Type B borers are already filled completely during insertion but must be withdrawn in an oblique position to prevent losses from the lower end.
- 5.2. In the case of free-flowing powder, the container shall be inclined, the borers inserted nearly horizontally with the slit downwards and withdrawn with the slit upwards.

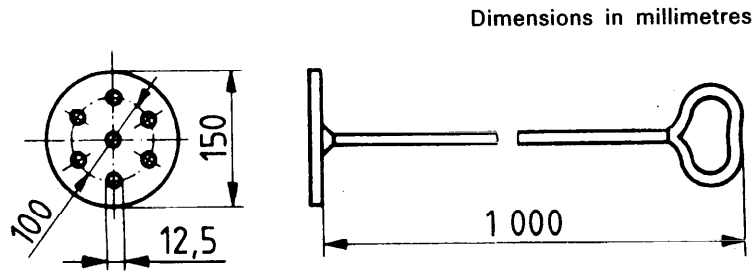

Figure 1: Recommended plunger for cans and buckets

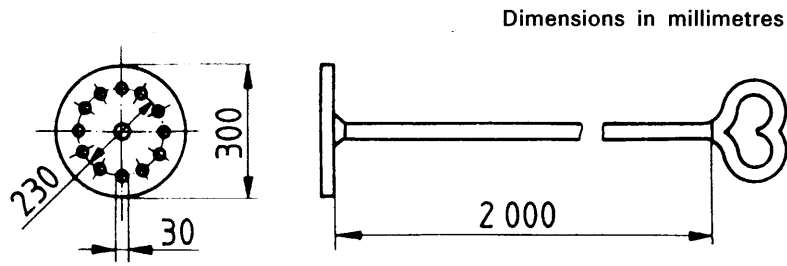

Figure 2: Suitable plunger for small tanks

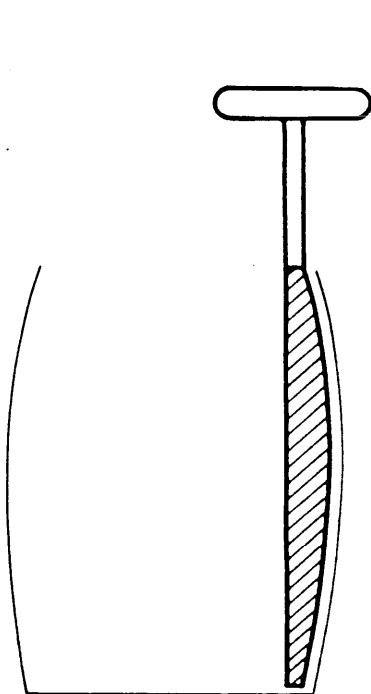

Figure 3: Suitable stirrer for mixing sweetened condensed milk

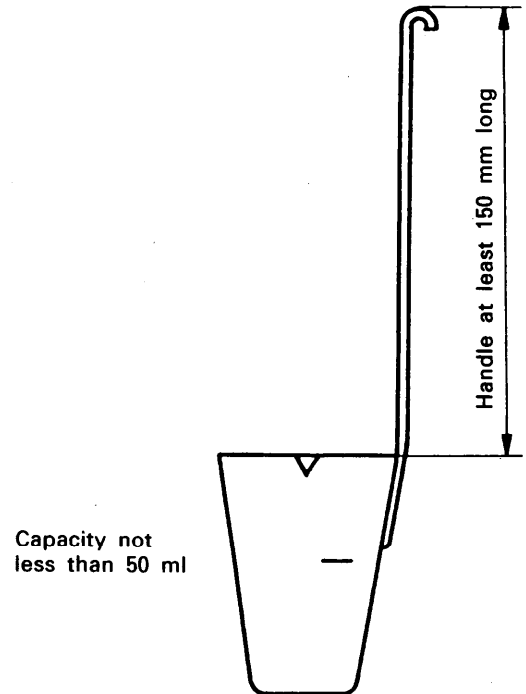

Figure 4: Suitable dipper for liquids

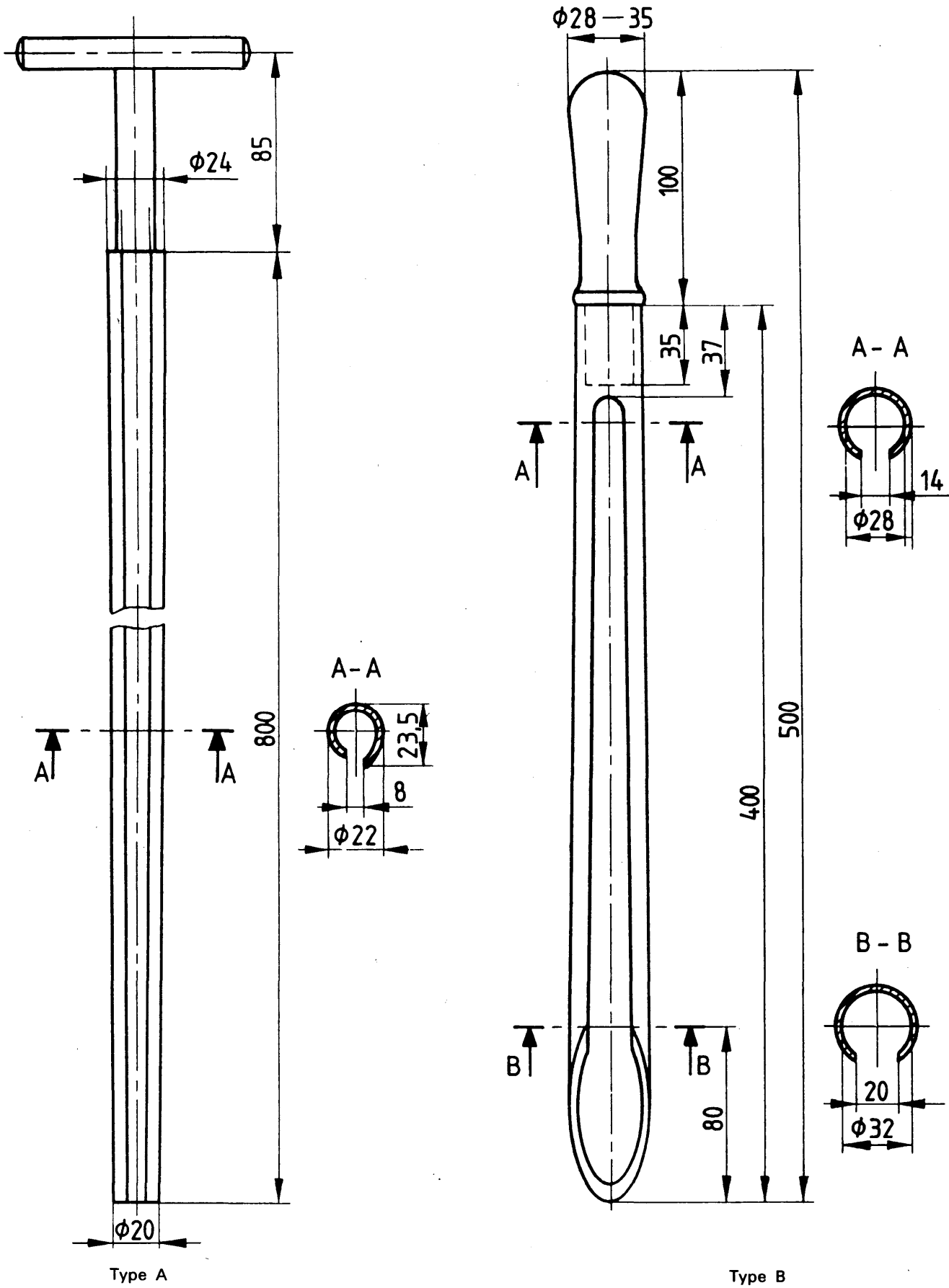

Figure 5: Dried-milk borers (all dimensions in millimetres)