

This document is meant purely as a documentation tool and the institutions do not assume any liability for its contents

► **B****COUNCIL DIRECTIVE****of 6 February 1970****on the approximation of the laws of the Member States relating to the permissible sound level and the exhaust system of motor vehicles**

(70/157/EEC)

(OJ L 42, 23.2.1970, p. 16)

Amended by:

	Official Journal		
	No	page	date
► <u>M1</u> Commission Directive 73/350/EEC of 7 November 1973	L 321	33	22.11.1973
► <u>M2</u> Council Directive 77/212/EEC of 8 March 1977	L 66	33	12.3.1977
► <u>M3</u> Commission Directive 81/334/EEC of 13 April 1981	L 131	6	18.5.1981
► <u>M4</u> Commission Directive 84/372/EEC of 3 July 1984	L 196	47	26.7.1984
► <u>M5</u> Council directive 84/424/EEC of 3 September 1984	L 238	31	6.9.1984
► <u>M6</u> Council Directive 87/354/EEC of 25 June 1987	L 192	43	11.7.1987
► <u>M7</u> Commission Directive 89/491/EEC of 17 July 1989	L 238	43	15.8.1989
► <u>M8</u> Council Directive 92/97/EEC of 10 November 1992	L 371	1	19.12.1992
► <u>M9</u> Commission Directive 96/20/EC of 27 March 1996	L 92	23	13.4.1996
► <u>M10</u> Commission Directive 1999/101/EC of 15 December 1999	L 334	41	28.12.1999

Amended by:

► <u>A1</u> Act of Accession of Denmark, Ireland and the United Kingdom of Great Britain and Northern Ireland	L 73	14	27.3.1972
► <u>A2</u> Act of Accession of Spain and Portugal	L 302	23	15.11.1985
► <u>A3</u> Act of Accession of Austria, Sweden and Finland (adapted by Council Decision 95/1/EC, Euratom, ECSC)	C 241 L 1	21 1	29.8.1994 1.1.1995
► <u>A4</u> Act concerning the conditions of accession of the Czech Republic, the Republic of Estonia, the Republic of Cyprus, the Republic of Latvia, the Republic of Lithuania, the Republic of Hungary, the Republic of Malta, the Republic of Poland, the Republic of Slovenia and the Slovak Republic and the adjustments to the Treaties on which the European Union is founded	L 236	33	23.9.2003

▼B**COUNCIL DIRECTIVE****of 6 February 1970****on the approximation of the laws of the Member States relating to the permissible sound level and the exhaust system of motor vehicles**

(70/157/EEC)

THE COUNCIL OF THE EUROPEAN COMMUNITIES,

Having regard to the Treaty establishing the European Economic Community, and in particular Article 100 thereof;

Having regard to the proposal from the Commission;

Having regard to the Opinion of the European Parliament ⁽¹⁾;Having regard to the Opinion of the Economic and Social Committee ⁽²⁾;Whereas the technical requirements which motor vehicles must satisfy pursuant to national laws relate, *inter alia*, to the permissible sound level and the exhaust system;Whereas those requirements differ from one Member State to another; whereas it is therefore necessary that all Member States adopt the same requirements either in addition to or in place of their existing rules, in order, in particular, to allow the EEC type approval procedure which was the subject of the Council Directive ⁽³⁾ of 6 February 1970 on the approximation of the laws of the Member States relating to the type approval of motor vehicles and their trailers to be applied in respect of each type of vehicle;

HAS ADOPTED THIS DIRECTIVE:

Article 1

For the purposes of this Directive, 'vehicle' means any motor vehicle intended for use on the road, with or without bodywork, having at least four wheels and a maximum design speed exceeding 25 kilometres per hour, with the exception of vehicles which run on ►M9 rails and of agricultural and forestry tractors and all mobile machinery. ◀

▼M3*Article 2*

No Member State may, on grounds relating to the permissible sound level and the exhaust system, refuse to grant EEC or national type-approval in respect of a type of motor vehicle or type of exhaust system or component of such a system regarded as a separate technical unit,

- if the vehicle satisfies the requirements of Annex I as regards the sound level and exhaust system,
- if the exhaust system or any component thereof, considered as a separate technical unit within the meaning of ►M9 Article 2 ◀ of Directive 70/156/EEC satisfies the requirements of Annex II.

Article 2a

1. No Member State may, on grounds relating to the permissible sound level and the exhaust system, refuse or prohibit the sale, registration, entry into service or use of any vehicle in which the sound level and the exhaust system satisfy the requirements of Annex I.

⁽¹⁾ OJ No C 160, 18.12.1969, p. 7.

⁽²⁾ OJ No C 48, 16.4.1969, p. 16.

⁽³⁾ OJ No L 42, 23.2.1970, p. 1.

▼M3

2. No Member State may, on grounds relating to the permissible sound level and the exhaust system, prohibit the placing on the market of an exhaust system or any component thereof considered as a separate technical unit within the meaning of ►**M9** Article 2 ◀ of Directive 70/156/EEC if, within the meaning of Article 2, it is of a type in respect of which a type-approval has been granted.

▼B*Article 3*

The amendments necessary for adjusting the requirements of ►**M9** the Annexes ◀ so as to take account of technical progress, with the exception of the requirements set out under ►**M3** items 5.2.2.1 and 5.2.2.5 of Annex I ◀, shall be adopted in accordance with the procedure laid down in Article 13 of the Council Directive on the type approval of motor vehicles and their trailers.

Article 4

1. Member States shall put into force the provisions containing the requirements needed in order to comply with this Directive within eighteen months of its notification and shall forthwith inform the Commission thereof.

2. Member States shall ensure that the texts of the main provisions of national law which they adopt in the field covered by this Directive are communicated to the Commission.

Article 5

This Directive is addressed to the Member States.

▼M9*List of Annexes*

- ANNEX I: ECType-approval in respect of the sound level of a type of motor vehicle
Appendix 1: Information document
Appendix 2: Type-approval certificate
- ANNEX II: EC type-approval of exhaust systems as separate technical units
Appendix 1: Information document
Appendix 2: Type-approval certificate
Appendix 3: Model for the EC type-approval mark
- ANNEX III: Checks on conformity of production
- ANNEX IV: Test track specifications

▼ **M8**

ANNEX I

EEC TYPE-APPROVAL IN RESPECT OF THE SOUND LEVEL OF A TYPE OF MOTOR VEHICLE

1. DEFINITIONS

For the purposes of this Directive:

1.1. **Type of vehicle**

means vehicles which do not differ essentially as regards the following parts:

- 1.1.1. the shape or materials of the bodywork (particularly the engine compartment and its soundproofing);
- 1.1.2. the length and width of the vehicle;
- 1.1.3. the type of engine (positive or compression ignition, two- or four-stroke, reciprocating or rotary piston, number and capacity of cylinders, number and type of carburettors or injection systems, arrangement of valves, rated maximum power and corresponding engine speed(s));
- 1.1.4. the transmission system, the gear ratio in which the test is performed and the relevant overall ratio(s);
- 1.1.5. the number, type and arrangement of the exhaust systems;
- 1.1.6. the number, type and arrangement of the intake systems.
- 1.1.7. Notwithstanding the provisions of items 1.1.2 and 1.1.4, vehicles other than those in categories M₁ and N₁ ► **M9** ⁽¹⁾ ◀ having the same type of engine and/or different overall gear ratios, may be regarded as vehicles of the same type.

However, if the above differences provide for a different test method, these differences are to be considered as a change of type.

1.2. **Exhaust and intake systems**1.2.1. *Exhaust systems*

means a complete set of parts necessary to reduce the noise produced by the vehicle's engine exhaust.

1.2.2. *Intake systems*

means a complete set of parts necessary to reduce the noise produced by the vehicle's engine intake.

- 1.2.3. For the purposes of this Directive, these systems do not include the manifolds.

1.3. **Different types of exhaust or intake system**

means systems characterized by fundamental differences, such as the following:

- 1.3.1. systems in which the components bear different trade marks or trade names;
- 1.3.2. systems in which the characteristics of the materials of a component differ, or in which the components are of different shape or size; a change in the plating procedure (galvanization, aluminium coating, etc.) is not deemed to produce a difference of type;
- 1.3.3. systems in which the operating principles of at least one component differ;
- 1.3.4. systems in which the components are combined differently.

(1) In accordance with the definitions given in Annex II A to Directive 70/156/EEC.

▼ M8

- 1.4. **Component of an exhaust or an intake system**
means one of the separate components which together form the exhaust system (e.g. exhaust pipes, the silencer proper) or the intake system (e.g. air filter).
- 1.5. **Overall gear ratio**
means the number of turns made by the engine per each turn of the driving wheels.
2. APPLICATION FOR EEC TYPE-APPROVAL

▼ M9

- 2.1. The application for EC type-approval pursuant to Article 3 (4) of Directive 70/156/EEC of a vehicle type with regard to its sound level shall be submitted by the vehicle manufacturer.
- 2.2. A model for the information document is given in Appendix 1.

▼ M8

- 2.3. A vehicle representative of the type in respect of which type-approval is sought must be submitted to the technical service responsible for the tests by the vehicle manufacturer
► **M9** ————— ◀.
- 2.3.1. In the case of item 1.1.7 the single vehicle, representative of the type in question, will be selected by the technical service conducting approval tests, in accordance with the vehicle manufacturer, as that with the lowest mass in running order with the shortest length and following the specification laid down in item 5.2.2.4.3.3.1.2.
- 2.4. At the request of the technical service, a specimen of the exhaust system and an engine of at least the same cylinder capacity and rated maximum power as that fitted to the vehicle in respect of which type-approval is sought must also be submitted.

▼ M9**▼ M8**

3. MARKINGS
- 3.1. The exhaust and intake system components, excluding fixing hardware and pipes, must bear:
- 3.1.1. the trade mark or name of the manufacturer of the systems and their components;
- 3.1.2. the manufacturer's trade description.
- 3.2. These markings must be clearly legible and indelible, even when the system is fitted to the vehicle.

▼ M9

4. GRANTING OF EC TYPE-APPROVAL
- 4.1. If the relevant requirements are satisfied, EC type-approval pursuant to Article 4 (3) and, if applicable, 4 (4) of Directive 70/156/EEC shall be granted.
- 4.2. A model for the EC type-approval certificate is given in Appendix 2.
- 4.3. An approval number in accordance with Annex VII to Directive 70/156/EEC shall be assigned to each vehicle type approved. The same Member State shall not assign the same number to another vehicle type.

▼ **M8**

5. SPECIFICATIONS

5.1. **General specifications**

5.1.1. The vehicle, its engine and exhaust and intake systems must be designed, constructed and mounted such that, under normal conditions of use and notwithstanding the vibrations to which they may be subject, the vehicle satisfies the requirements of this Directive.

5.1.2. The systems must be designed, constructed and mounted so that reasonable resistance to the corrosion phenomena to which they are exposed is obtained having regard to the conditions of use of the vehicle.

5.2. **Specifications relating to sound levels**5.2.1. *Method of measurement*

5.2.1.1. The sound emitted by the type of vehicle submitted for EEC type-approval must be measured in accordance with each of the two methods described in item 5.2.2.4 in the case of moving vehicles and item 5.2.3.4 in the case of stationary vehicles, respectively ⁽¹⁾.

Vehicles having a maximum permissible mass exceeding 2 800 kg must be subjected to an additional measurement of the compressed air noise with the vehicle stationary in accordance with item 5.4, if corresponding brake equipment is part of the vehicle.

5.2.1.2. The values measured as specified in item 5.2.1.1 must be recorded in the test report and in a certificate corresponding to the model shown in ► **M9** Appendix 2 ◀. Details of the ambient conditions, namely, test track (type of surface), air temperature, wind (direction and speed) and ambient noise must also be recorded in the test report.

5.2.2. *Sound level of moving vehicles*

5.2.2.1. Limiting values

The sound level measured in accordance with items 5.2.2.2 to 5.2.2.5, inclusive, of this Annex shall not exceed the following limits:

	Vehicle categories	Values expressed in dB (A) (decibels (A))
5.2.2.1.1.	Vehicles intended for the carriage of passengers, and comprising not more than nine seats including the driver's seat	74
5.2.2.1.2.	Vehicles intended for the carriage of passengers and equipped with more than nine seats, including the driver's seat; and having a maximum permissible mass of more than 3,5 tonnes and:	
5.2.2.1.2.1.	— with an engine power of less than 150 kW	78
5.2.2.1.2.2.	— with an engine power of not less than 150 kW	80
5.2.2.1.3.	Vehicles intended for the carriage of passengers and equipped with more than nine seats including the driver's seat; vehicles intended for the carriage of goods:	
5.2.2.1.3.1.	— with a maximum permissible mass not exceeding 2 tonnes	76
5.2.2.1.3.2.	— with a maximum permissible mass exceeding 2 tonnes but not exceeding 3,5 tonnes	77

⁽¹⁾ A stationary vehicle test is conducted in order to establish a reference value for the authorities which employ this method for the inspection of vehicles in service.

▼ **M8**

	Vehicle categories	Values expressed in dB (A) (decibels (A))
5.2.2.1.4.	Vehicles intended for the carriage of goods and having a maximum permissible mass exceeding 3,5 tonnes:	
5.2.2.1.4.1.	— with an engine power of less than 75 kW	77
5.2.2.1.4.2.	— with an engine power of not less than 75 kW but less than 150 kW	78
5.2.2.1.4.3.	— with an engine power of not less than 150 kW	80

However:

- for vehicles of categories 5.2.2.1.1 and 5.2.2.1.3, the limit values are increased by 1 dB (A) if they are equipped with a direct injection diesel engine,
- for vehicles with a maximum permissible mass of over two tonnes designed for off-road use, the limit values are increased by 1 dB (A) if their engine power is less than 150 kW and 2 dB (A) if their engine power is 150 kW or more,
- for vehicles in category 5.2.2.1.1., equipped with a manually operated gear box having more than four forward gears and with an engine developing a maximum power exceeding 140 kW/t and whose permissible maximum power/maximum mass ratio exceeds 75 kW/t, the limit values are increased by 1 dB (A) if the speed at which the rear of the vehicle passes the line BB' (Figure 1) in third gear is greater than 61 km/h.

5.2.2.2. Measuring instruments

5.2.2.2.1. Acoustic measurements

The apparatus used for measuring the noise level must be a precision sound-level meter of the type described in Publication 179 'Precision sound level meters', second edition, of the International Electrotechnical Commission (IEC). Measurements must be carried out using the 'fast' response of the sound-level meter and the 'A' weighting curve which are also described in that publication.

At the beginning and end of each set of measurements, the sound-level meter must be calibrated according to the manufacturer's instructions by means of an appropriate sound source (e.g. a pistonphone). The test must be considered invalid if the sound-level meter errors registered during this calibration exceed 1 dB.

5.2.2.2.2. Speed measurements

The engine speed and vehicle speed on the test section shall be determined with an accuracy of 3 % or better.

5.2.2.3. Conditions of measurement

5.2.2.3.1. Test site

The test site must consist of a central acceleration section surrounded by a substantially flat test area. The test acceleration section must be level; the track surface must be dry and such that rolling noise remains low.

The test track must be such that the conditions of a free sound field between the sound source and the microphone are attained to within 1 dB. These conditions shall be deemed to be met if there are no large sound-reflecting objects such as fences, rocks, bridges or buildings within 50 m of the centre of the acceleration section. The test-track surface must comply with the specifications in ► **M9** Annex IV ◀.

There must be no obstacle which could affect the sound field within the vicinity of the microphone and no persons shall stand between the microphone and the sound source. The

▼ M8

observer carrying out the measurements must so position himself as not to affect the readings of the measuring instrument.

5.2.2.3.2. Meteorological conditions

Measurements must not be made in poor atmospheric conditions. It must be ensured that the results are not affected by gusts of wind.

5.2.2.3.3. Ambient noise

For measurements, the A-weighted sound level of sound sources other than those of the vehicle to be tested and of wind effects must be at least 10 dB (A) below the sound level produced by the vehicle. A suitable windscreen may be fitted to the microphone provided that account is taken of its effect on the sensitivity and directional characteristics of the microphone.

5.2.2.3.4. Condition of vehicle

For these measurements, the vehicle must be in running order as defined in item 2.6 of Annex I to Directive 70/156/EEC and, except in the case of vehicles which cannot be uncoupled, without trailer or semi-trailer.

▼ M9

The tyres used for the test are selected by the vehicle manufacturer and shall comply with commercial practice and be available on the market; they shall correspond to one of the tyre-size designations (see item 2.17. of Annex II to Council Directive 92/23/EEC⁽¹⁾) indicated for the vehicle by the vehicle manufacturer according to item 1.5. of the Addendum to Appendix 2 and in the case of vehicles of categories M₁ and N₁ meet the requirements of Directive 89/459/EEC regarding the minimum tread depth; for vehicles of other categories, the minimum tread depth specified in Directive 89/459/EEC will be applied as if the vehicles were within the scope of that Directive. The tyres must be inflated to the appropriate pressure(s) for the test mass of the vehicle.

▼ M8

Before the measurements are made, the engine must be brought to its normal operating condition as regards temperatures, settings, fuel, spark plugs, carburettor(s), etc. (as appropriate). If the vehicle is fitted with fan(s) having an automatic actuating mechanism, this system must not be interfered with during the measurements.

Only the normal highway drive must be engaged in vehicles with more than two drive wheels.

5.2.2.4. Method of measurement

5.2.2.4.1. Nature and number of measurements

The maximum sound level expressed in A-weighted decibels (dB (A)) shall be measured as the vehicle is driven between lines AA' and BB' (Figure 1). The measurement shall be invalid if an abnormal discrepancy between the peak value and the general sound level is recorded.

At least two measurements must be taken on each side of the vehicle.

5.2.2.4.2. Positioning of the microphone

The microphone must be located at a distance of $7,5 \pm 0,2$ m from the reference line CC' (Figure 1) of the track and $1,2 \pm 0,1$ m above the ground. Its axis of maximum sensitivity must be horizontal and perpendicular to the path of the vehicle (line CC').

5.2.2.4.3. Conditions of operation

5.2.2.4.3.1. General conditions

For all measurements, the vehicle must be driven in a straight line over the acceleration section in such a way that the median

⁽¹⁾ OJ No L 129, 14. 5. 1992, p. 95.

▼ **M8**

longitudinal plane of the vehicle is as close as possible to the line CC'.

The vehicle must approach the line AA' at a steady initial road speed as specified in items 5.2.2.4.3.2 and 5.2.2.4.3.3. When the front end of the vehicle has reached the line AA', the accelerator control is fully operated as rapidly as practicable and held in the fully opened position until the rear of the vehicle reaches the line BB'; the accelerator control must be released as quickly as possible.

The trailers of articulated vehicles which cannot be uncoupled must not be taken into account as regards the crossing of line BB'.

5.2.2.4.3.2. Approach speed

The vehicle must approach the line AA' at a steady speed corresponding to the lower of the following two speeds:

- 50 km/h,
- the speed corresponding to an engine speed equal to three-quarters of the speed, S, at which the engine develops its rated maximum power, in the case of vehicles of category M_1 and in the case of vehicles of the other categories having an engine power not greater than 225 kW,
- the speed corresponding to an engine speed equal to half the speed, S, at which the engine develops its rated maximum power, in the case of vehicles not belonging to category M_1 having an engine power greater than 225 kW.

However, if in the case of vehicles equipped with an automatic transmission having more than two discrete ratios there is a change-down to first gear during the test, the manufacturer may select either of the following test procedures:

- the speed, V, of the vehicle is increased to a maximum of 60 km/h in order to avoid such a change-down,
or
- the speed, V, must remain at 50 km/h and the fuel supply to the engine limited to 95 % of the supply necessary for full load. This condition is considered to be satisfied:
 - in the case of a spark-ignition engine, when the angle of the throttle opening is 90 %, and
 - in the case of a compression-ignition engine, when the movement of the central rack of the injection pump is limited to 90 % of its travel.

If the vehicle is equipped with an automatic transmission which has no manual override, it must be tested at different approach speeds, namely 30, 40, and 50 km/h, or at three-quarters of maximum road speed if this value is lower. The test result is that obtained at the speed which produces the maximum sound level.

5.2.2.4.3.3. Choice of gear ratios (in vehicles fitted with gearboxes)

5.2.2.4.3.3.1. Manually-operated, non-automatic gearbox

5.2.2.4.3.3.1.1. Vehicles in categories M_1 and N_1 equipped with a manually operated gearbox having not more than four forward gear ratios must be tested in second gear.

Vehicles in these categories equipped with a manually operated gearbox having more than four forward gear ratios must be tested in second and third gears successively. Only overall gear ratios intended for normal road use are considered. The arithmetic mean of the sound levels recorded for each of these two conditions shall be calculated.

If during the test in second gear, the engine speed exceeds the engine speed, S, at which the engine develops its rated maximum power, the test must be repeated with an approach speed and/or approach engine speed reduced by steps of 5 % of S until the engine speed attained no longer exceeds S. ► **M9** If the engine speed 'S' is still attained with an approach engine speed corresponding to the idle speed, then the test will be performed only in third gear and the relevant results have to be evaluated. ◀

▼ M8

However, the vehicles in category M_1 having more than four forward gears and equipped with an engine developing a maximum power greater than 140 kW, and whose permissible maximum-power/maximum-mass ratio exceeds 75 kW/t, may be tested in third gear only, provided that the speed at which the rear of the vehicle passes the line BB' in third gear is greater than 61 km/h.

- 5.2.2.4.3.3.1.2. Vehicles other than those in categories M_1 and N_1 in which the total number of forward gear ratios is x' (including the ratios obtained by means of an auxiliary gearbox or a multiple-ratio drive axle) must be tested using, in turn, ratios equal to or higher than x/n ⁽¹⁾ ⁽²⁾.

The test result will be that obtained from the ratio producing the maximum sound level.

Shifting up gears from x/n must be terminated in the gear X where the engine speed, S, at which the engine develops its rated maximum power is for the last time reached when passing the line BB'.

In the case of vehicles having different overall gear ratios (including a different number of gears) the representativity of the type by the test vehicle is determined as follows:

- if the highest sound level is obtained between the ratios x/n and X the vehicle selected is deemed representative of its type,
- if the highest sound level is obtained at ratio x/n the vehicle selected is deemed representative of its type only for those vehicles which have a lower overall gear ratio at x/n ,
- if the highest sound level is obtained at ratio X the vehicle selected is deemed representative of its type only for those vehicles which have a higher overall gear ratio at X.

▼ M9

However, the vehicle is deemed representative of its type also, if, on the applicant's request, the tests are extended over more ratios than foreseen, and the highest sound level is obtained between the extreme ratios tested.

▼ M8

- 5.2.2.4.3.3.2. Automatic transmission equipped with manual override

The test is conducted with the selector in a position recommended by the manufacturer for 'normal' driving. External downshifts (e.g. kickdown) shall be put out of operation.

- 5.2.2.5. Interpretation of results

- 5.2.2.5.1. To take account of inaccuracies in the measuring instruments, the result obtained from each measurement is determined by deducting 1 dB (A) from the meter reading.

- 5.2.2.5.2. The measurements are considered valid if the difference between two consecutive measurements on the same side of the vehicle does not exceed 2 dB (A).

- 5.2.2.5.3. The highest sound level measured shall constitute the test result. Should the result exceed the maximum permissible sound level for the category of vehicle tested by 1 dB (A), two further measurements shall be made at the corresponding microphone position. Three of the four measurements thus obtained at that microphone position must fall within the prescribed limits.

- 5.2.3. *Sound level of the stationary vehicle*

- 5.2.3.1. Sound level in the vicinity of vehicles

In order to facilitate subsequent checks on vehicles in use, the sound level must be measured close to the exhaust system outlet in accordance with the following requirements and the measurement results entered in the test report drawn up for the purpose of issuing the certificate referred to in ► **M9** Appendix 2 ◀.

(1) Where: $n = 2$ for vehicles having an engine power not greater than 225 kW;
 $n = 3$ for vehicles having an engine power greater than 225 kW.

(2) If x/n does not correspond to a whole number, the nearest higher ratio must be used.

▼ **M8**

- 5.2.3.2. Measuring instruments
- 5.2.3.2.1. Acoustic measurements
- A precision sound-level meter as defined in item 5.2.2.2.1 must be used for the measurements.
- 5.2.3.2.2. Measurement of engine speed
- The engine speed is determined by means of a tachometer having an accuracy of 3 % or better. The tachometer may not be the one fitted to the vehicle.
- 5.2.3.3. Conditions of measurement
- 5.2.3.3.1. Test site (Figure 2)
- Any area not subject to significant acoustic disturbance may be used as a test site. Flat surfaces which are covered in concrete, asphalt or any other hard surfacing and possess a high degree of reflectivity are particularly suitable; surfaces consisting of earth which has been tamped down must not be used.
- The test site must be in the form of a rectangle, the sides of which are at least 3 m from the sides of the vehicle. This rectangle must not contain any significant obstacles, e.g. an individual other than the observer and the driver. The vehicle must be positioned within the abovementioned rectangle so that the microphone is at least 1 m from any kerbstone.
- 5.2.3.3.2. Meteorological conditions
- Measurements must not be made in poor atmospheric conditions. It must be ensured that the results are not affected by gusts of wind.
- 5.2.3.3.3. Ambient noise
- Readings on the measuring instruments produced by ambient noise and wind must be at least 10 dB (A) below the sound level to be measured. A suitable windscreen may be fitted to the microphone provided that account is taken of its effect on the sensitivity of the microphone.
- 5.2.3.3.4. Condition of the vehicle
- The vehicle engine must be brought to normal running temperature before measurements commence. If the vehicle is fitted with fan(s) having an automatic actuating mechanism, this system must not be interfered with during the sound-level measurements.
- During measurements, the gear lever must be in the neutral position.
- 5.2.3.4. Method of measurement
- 5.2.3.4.1. Nature and number of measurements
- The maximum sound level expressed in A-weighted decibels (dB (A)) must be measured during the operating period referred to in item 5.2.3.4.3.
- At least three measurements must be taken at each measuring point.
- 5.2.3.4.2. Position of the microphone (Figure 2)
- The microphone must be located level with the exhaust outlet or 0,2 m above the test-track surface, whichever is the higher. The microphone diaphragm must face the exhaust outlet at a distance of 0,5 m from the latter. The axis of maximum sensitivity of the microphone must be parallel to the track surface at an angle of $45^\circ \pm 10^\circ$ to the vertical plane defined by the direction in which the exhaust gases are emitted.
- The microphone must be positioned to the side of this vertical plane which gives the greatest possible distance between the microphone and the vehicle contour.
- If the exhaust system has several outlets, the centres of which are not more than 0,3 m apart, and which are connected to the same silencer, the microphone must face the outlet closest to the vehicle contour or the outlet which is the highest above the track surface. In all other cases separate measurements

▼ **M8**

must be taken at each of them, the highest figure recorded being taken as the test value.

In the case of vehicles fitted with a vertical exhaust outlet (e.g. commercial vehicles), the microphone must be positioned at the level of the exhaust outlet, facing upwards with its axis vertical. It must be positioned at a distance of 0,5 m from the side of the vehicle closest to the exhaust outlet.

Where the design of the vehicle is such that the microphone cannot be located as shown in Figure 2 because of the presence of obstacles which form part of the vehicle (e.g. spare wheel, fuel tank, battery compartment), a drawing clearly indicating the position for the microphone must be made when the measurement is conducted. As far as possible, the microphone must be more than 0,5 m from the nearest obstacle, and its axis of maximum sensitivity must face the exhaust outlet from the position least concealed by the abovementioned obstacles.

5.2.3.4.3. Conditions of engine operation

Engine speed must be stabilized at three-quarters of the speed (S) at which the engine develops rated maximum power.

When constant engine speed is reached, the throttle must be rapidly returned to the idling position. The sound level must be measured over an operating period comprising brief maintenance of constant engine speed and the entire deceleration period, the maximum sound-level meter reading being taken as the test result.

5.2.3.5. Results (test report)

5.2.3.5.1. The test report drawn up for the purpose of issuing the certificate referred to in ► **M9** Appendix 2 ◀ must indicate all relevant data, particularly those used in measuring the sound of the stationary vehicle.

5.2.3.5.2. Readings, rounded off to the nearest decibel, shall be taken from the measuring instrument.

Only those values obtained from three consecutive measurements which do not differ by more than 2 dB (A) respectively are taken into consideration.

5.2.3.5.3. The highest of these three values shall constitute the test results.

5.3. **Exhaust systems containing fibrous materials**

5.3.1. Fibrous materials may not be used in the construction of silencers unless suitable measures are undertaken at the design or production stages to ensure that the efficiency required to comply with the limits imposed in item 5.2.2.1 is achieved on the road. Such a silencer is considered to be efficient on the road if the exhaust gases are not in contact with the fibrous materials or if the silencer of the prototype vehicle tested in accordance with the requirements of items 5.2.2 and 5.2.3 has been put into a normal state for road use before the sound-level measurements are taken. This can be achieved by using one of the three tests described in items 5.3.1.1, 5.3.1.2 and 5.3.1.3, below, or by removing the fibrous materials from the silencer.

5.3.1.1. Continuous road operation for 10 000 km

5.3.1.1.1. About half this operation shall consist of town driving and the other half of long-distance runs at high speed; continuous road operation can be replaced by a corresponding test-track programme.

5.3.1.1.2. The two speed regimes must be alternated on several occasions.

5.3.1.1.3. The complete test programme must include a minimum of 10 breaks of at least three-hours duration in order to reproduce the effects of cooling and any condensation which may occur.

5.3.1.2. Conditioning on a test bench

5.3.1.2.1. Using standard parts and observing the vehicle manufacturer's instructions, the silencer must be fitted to the engine, which is coupled to a dynamometer.

▼ M8

- 5.3.1.2.2. The test must be conducted in six six-hour periods with a break of at least 12 hours between each period in order to reproduce the effect of cooling and any condensation which may occur.
- 5.3.1.2.3. During each six-hour period, the engine shall be run under the following conditions in turn:
1. five minutes at idling speed;
 2. one-hour sequence under $\frac{1}{4}$ load at $\frac{3}{4}$ of rated maximum speed (S);
 3. one-hour sequence under $\frac{1}{2}$ load at $\frac{3}{4}$ of rated maximum speed (S);
 4. 10-minute sequence under full load at $\frac{3}{4}$ of rated maximum speed (S);
 5. 15-minute sequence under $\frac{1}{2}$ load at rated maximum speed (S);
 6. 30-minute sequence under $\frac{1}{4}$ load at rated maximum speed (S).
- Total duration of the six sequences: three hours.
- Each period must comprise two sets of the six abovementioned sequences.
- 5.3.1.2.4. During the test, the silencer must not be cooled by a forced draught simulating normal airflow around the vehicle. Nevertheless, at the request of the manufacturer, the silencer may be cooled in order not to exceed the temperature recorded at its inlet when the vehicle is running at maximum speed.
- 5.3.1.3. **Conditioning by pulsation**
- 5.3.1.3.1. The exhaust system or components thereof must be fitted to the vehicle referred to in 2.3 or the engine referred to in 2.4. In the former case the vehicle must be mounted on a roller dynamometer. In the second case, the engine must be mounted on a dynamometer.
- The test apparatus, a detailed diagram of which is shown in Figure 3, must be fitted at the outlet of the exhaust system. Any other apparatus providing equivalent results is acceptable.
- 5.3.1.3.2. The test apparatus must be adjusted in such a way that the exhaust-gas flow is alternately interrupted and re-established by the quick-action valve for 2 500 cycles.
- 5.3.1.3.3. The valve must open when the exhaust-gas back pressure, measured at least 100 mm downstream of the intake flange, reaches a value of between 0,35 and 0,40 bar. It must close when this pressure does not differ by more than 10 % from its stabilized value with the valve open.
- 5.3.1.3.4. The time-delay switch shall be set for the duration of gas exhaust resulting from the provisions laid down in item 5.3.1.3.3 above.
- 5.3.1.3.5. Engine speed must be 75 % of the speed (S) at which the engine develops maximum power.
- 5.3.1.3.6. The power indicated by the dynamometer must be 50 % of the full-throttle power measured at 75 % of engine speed (S).
- 5.3.1.3.7. Any drainholes must be closed off during the test.
- 5.3.1.3.8. The entire test must be completed within 48 hours. If necessary, one cooling period may be observed after each hour.
- 5.3.2. If the provisions of ► **M9** Article 11 (2) or 11 (3) ◀ of Directive 70/156/EEC concerning EEC type-approval are to be applied, the test method set out in item 5.3.1.2 above must be employed.

5.4. Compressed air noise**5.4.1. Method of measurement**

The measurement is performed at microphone positions 2 and 6 according to Figure 4, with the vehicle stationary. The highest A-weighted noise levels are registered during venting the pressure regulator and during ventilating after the use of both the service and parking brakes.

▼ M8

The noise during venting the pressure regulator is measured with the engine at idling speed.

The ventilating noise is registered while operating the service and parking brakes; before each measurement, the air-compressor unit has to be brought up to the highest permissible operating pressure, and then the engine switched off.

5.4.2. *Evaluation of the results*

For all microphone positions two measurements are taken. In order to compensate for inaccuracies of the measuring equipment, the meter reading is reduced by 1 dB (A), and the reduced value is taken as the result of measurement. The results are taken as valid if the difference between the measurements at one and the same microphone position does not exceed 2 dB (A).

The highest value measured is taken as the test result. If this value exceeds the noise limit by 1 dB (A), two additional measurements are to be taken at the corresponding microphone position. In this case three out of the four results of measurement thus obtained at that microphone position must have to comply with the noise limit.

5.4.3. *Limiting value*

The sound level shall not exceed the limit of 72 dB (A).

▼ M9

6. MODIFICATIONS OF THE TYPE AND AMENDMENTS OF APPROVAL

6.1. In the case of modifications of the type approved pursuant to this Directive, the provisions of Article 5 of Directive 70/156/EEC shall apply.

▼ M8

7. CONFORMITY OF PRODUCTION

▼ M9

7.1. Measures to ensure the conformity of production shall be taken in accordance with the requirements laid down in Article 10 of Directive 70/156/EEC.

7.2. Special provisions:

7.2.1. The tests referred to in item 2.3.5. of Annex X to Directive 70/156/EEC are those laid down in Annex III (I) to this Directive.

7.2.2. The frequency of inspections referred to in item 2.4. of Annex X to Directive 70/156/EEC is normally one every two years.

▼ **M8**

Figure 1

Microphone positions for the measurement of a moving vehicle

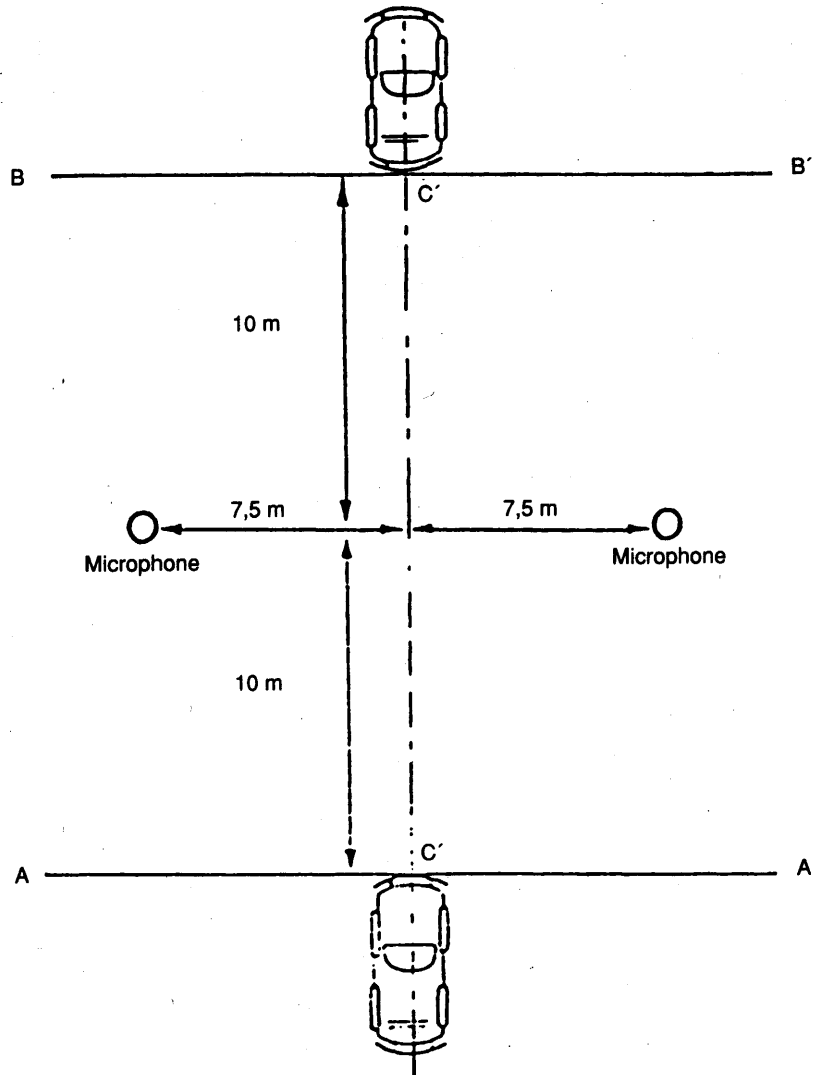

▼ M8

Figure 2
 Test site and microphone positions for the measurement of a stationary vehicle
 All distances are given in metres

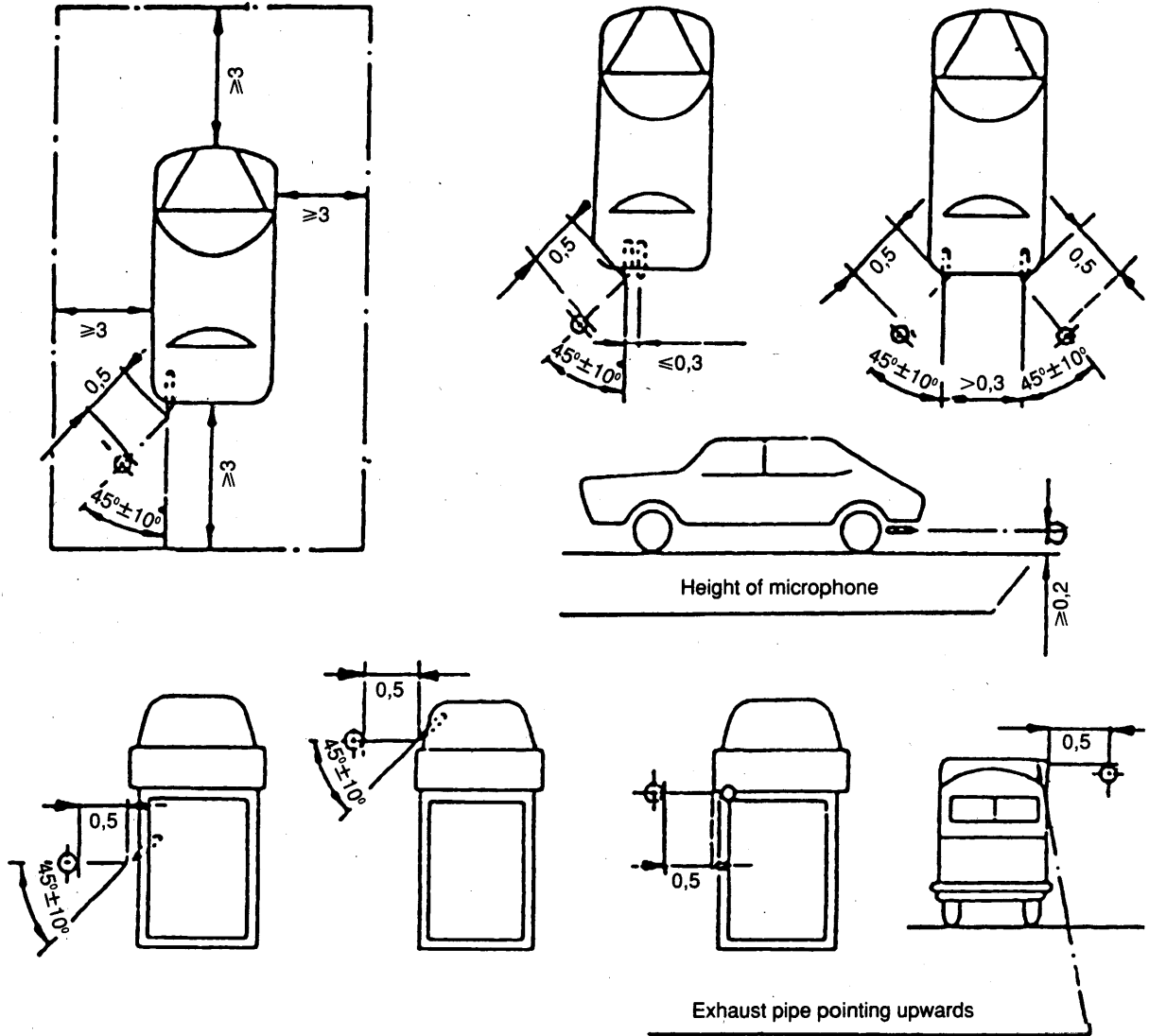

▼ M8

Figure 3
Test apparatus for conditioning by pulsation

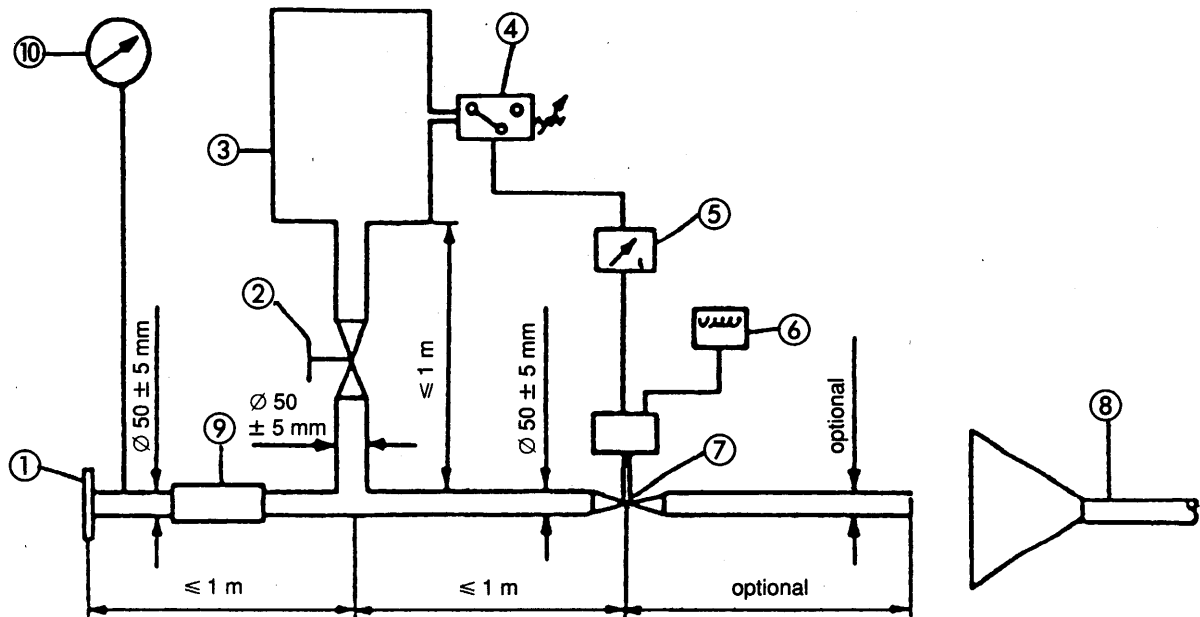

- ① Inlet flange or sleeve for connection to the rear of the test exhaust system.
- ② Hand-operated regulating valve.
- ③ Compensating reservoir having a capacity of 35 to 40 litres.
- ④ Pressure switch with an operating range of 0,05 to 2,5 bar.
- ⑤ Time delay switch.
- ⑥ Impulse counter.
- ⑦ Quick response valve, such as exhaust brake valve, 60 mm in diameter, operated by a pneumatic cylinder with an output of 120 N at 4 bar. The response time, both when opening and closing, must not exceed 0,5 seconds.
- ⑧ Exhaust gas evacuation.
- ⑨ Flexible pipe.
- ⑩ Pressure gauge.

▼ **M8**

Figure 4

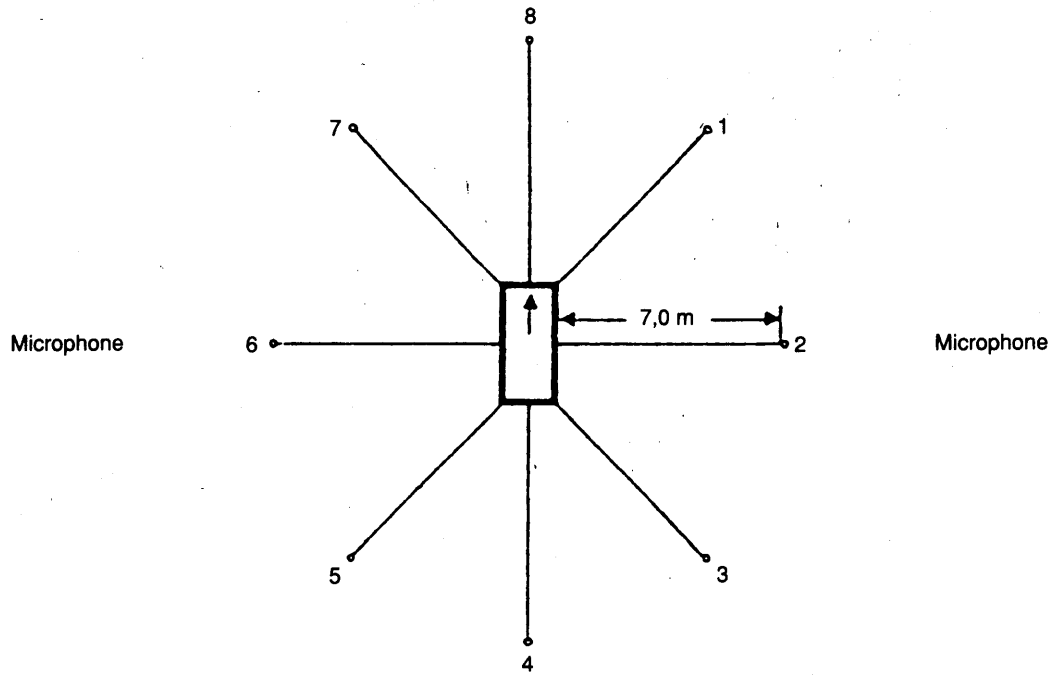
Microphone positions for measurement of compressed air noise

The measurement is performed on the stationary vehicle according to Figure 4, using two microphone positions at a distance of 7 m from the contour of the vehicles, and at 1,2 m above the ground.

▼ **M9***Appendix 1*

Information document No ... pursuant to Annex I of Council Directive 70/156/EEC (*) relating to EC type-approval of a vehicle with respect to the permissible sound level and the exhaust system (Directive 70/157/EEC, as last amended by Directive .../.../EC)

The following information, if applicable, must be supplied in triplicate and include a list of contents. Any drawings must be supplied in appropriate scale and in sufficient detail on size A4 or on a folder of A4 format. Photographs, if any, must show sufficient detail.

If the systems, components or separate technical units have electronic controls, information concerning their performance must be supplied.

0. **General**
- 0.1. Make (trade name of manufacturer):
- 0.2. Type and general commercial description(s):
- 0.3. Means of identification of type, if marked on the vehicle (b):
- 0.3.1. Location of that marking:
- 0.4. Category of vehicle (c):
- 0.5. Name and address of manufacturer:
- 0.8. Address(es) of assembly plant(s):

(*) The item numbers and footnotes used in this information document correspond to those set out in Annex I to Directive 70/156/EEC.
Items not relevant for the purpose of this Directive are omitted.

▼ **M9**

1. **General construction characteristics of the vehicle**
 - 1.1. Photographs and/or drawings of a representative vehicle:
 - 1.3.3. Powered axles (number, position, interconnection):
 - 1.6. Position and arrangement of the engine:
 2. **Masses and dimensions (e)** (in kg and mm) (Refer to drawing where applicable)
 - 2.4. Range of vehicle dimensions (overall)
 - 2.4.1. For chassis without bodywork
 - 2.4.1.1. Length (j):
 - 2.4.1.2. Width (k):
 - 2.4.2. For chassis with bodywork
 - 2.4.2.1. Length (j):
 - 2.4.2.2. Width (k):
 - 2.6. Mass of the vehicle with bodywork in running order, or mass of the chassis with cab if the manufacturer does not fit the bodywork (with standard equipment, including coolant, oils, fuel, tools, spare wheel and driver) (o) (maximum and minimum):
3. **Power plant (q)**
 - 3.1. Manufacturer:
 - 3.1.1. Manufacturer's engine code: (As marked on the engine, or other means of identification)
 - 3.2. Internal combustion engine
 - 3.2.1.1. Working principle: positive ignition /compression ignition, four stroke/two stroke (!)
 - 3.2.1.2. Number and arrangement of cylinders:
 - 3.2.1.2.3. Firing order:
 - 3.2.1.3. Engine capacity (s): cm³
 - 3.2.1.8. Maximum net power (t): kW at min⁻¹ (manufacturer's declared value)
 - 3.2.4. Fuel feed
 - 3.2.4.1. By carburettor(s): yes/no (!)
 - 3.2.4.1.2. Type(s):
 - 3.2.4.1.3. Number fitted:
 - 3.2.4.2. By fuel injection (compression ignition only): yes/no (!)
 - 3.2.4.2.2. Working principle: Direct injection/pre-chamber/swirl chamber (!)
 - 3.2.4.2.4. Governor
 - 3.2.4.2.4.1. Type:
 - 3.2.4.2.4.2.1. Cut-off point under load: min⁻¹
 - 3.2.4.3. By fuel injection (positive ignition only): yes/no (!)
 - 3.2.4.3.1. Working principle: Intake manifold (single-/multi-point (!))/direct injection/other (specify) (!)

(!) Delete where not applicable.

▼ **M9**

- 3.2.8. Intake system
- 3.2.8.4.2. Air filter, drawings:; or
- 3.2.8.4.2.1. Make(s):
- 3.2.8.4.2.2. Type(s):
- 3.2.8.4.3. Intake silencer, drawings:, or
- 3.2.8.4.3.1. Make(s):
- 3.2.8.4.3.2. Type(s):
- 3.2.9. Exhaust system
- 3.2.9.2. Description and/or drawing of the exhaust system:
- 3.2.9.4. Exhaust silencer(s):
- For front, centre, rear silencer: construction, type, marking; where relevant for exterior noise: reducing measures in the engine compartment and on the engine:
- 3.2.9.5. Location of the exhaust outlet:
- 3.2.9.6. Exhaust silencer containing fibrous materials:
- 3.2.12.2.1. Catalytic convertor: yes/no (!)
- 3.2.12.2.1.1. Number of catalytic convertors and elements:
- 3.3. Electric motor
- 3.3.1. Type (winding, excitation):
- 3.3.1.1. Maximum hourly output: kW
- 3.3.1.2. Operating voltage:..... V
- 3.4. Other engines or motors or combinations thereof (particulars regarding the parts of such engines or motors):
4. **Transmission (v)**
- 4.2. Type (mechanical, hydraulic, electric, etc.):
- 4.6. Gear ratios

Gear	Internal gearbox ratios (ratios of engine to gearbox output shaft revolutions)	Final drive ratio(s) (ratio of gearbox output shaft to driven wheel revolutions)	Total gear ratios
Maximum for CVT (*)			
1			
2			
3			
...			
Minimum for CVT (*)			
Reverse			

(*) Continuously variable transmission

(!) Delete where not applicable.

▼M9

- 4.7. Maximum vehicle speed (and gear in which this is achieved) (in km/h) (w):
- 6. **Suspension**
- 6.6. Tyres and wheels
- 6.6.2. Upper and lower limits of rolling radii
- 6.6.2.1. Axle 1:
- 6.6.2.2. Axle 2:
- 6.6.2.3. Axle 3:
- 6.6.2.4. Axle 4:
- etc.
- 9. **Bodywork** (not applicable for vehicles of category M1)
- 9.1. Tpe of bodywork:
- 9.2. Materials used and method of constriction
- 12. **Miscellaneous**
- 12.5. Details of any non-engine devices designed to reduce noise (if not covered by other items):

Additional information in the case of off-road vehicles

- 1.3. Number of axles and wheels:
- 2.4.1. For chassis without bodywork
- 2.4.1.4.1. Approach angle (na): degrees
- 2.4.1.5.1. Departure angle (nb): degrees
- 2.4.1.6. Ground clearance (as defined in point 4.5 of section A of Annex II to Directive 70/156/EEC)
- 2.4.1.6.1. Between the axles:
- 2.4.1.6.2. Under the front axle(s):
- 2.4.1.6.3. Under the rear axle(s):
- 2.4.1.7. Ramp angle (nc): degrees
- 2.4.2. For chassis with bodywork
- 2.4.2.4.1. Approach angle (na): degrees
- 2.4.2.5.1. Departure angle (nb): degrees
- 2.4.2.6. Ground clearance (as defined in point 4.5 of section A of Annex II to Directive 70/156/EEC)
- 2.4.2.6.1. Between the axles:
- 2.4.2.6.2. Under the front axle(s):
- 2.4.2.6.3. Under the rear axle(s):
- 2.4.2.7. Ramp angle (nc): degrees
- 2.15. Hill-starting ability (solo vehicle): percent
- 4.9. Differential lock: yes/no/optional (!)

Date, File

(!) Delete where not applicable.

▼ **M9**

Appendix 2

MODEL**EC TYPE-APPROVAL CERTIFICATE**

(Maximum Format: A4 (210 × 297 mm))

Stamp of administration

Communication concerning the

- type-approval ⁽¹⁾
- extension of type-approval ⁽¹⁾
- refusal of type-approval ⁽¹⁾
- withdrawal of type-approval ⁽¹⁾

of a type of a vehicle/component/separate technical unit ⁽¹⁾ with regard to Directive .../.../EEC, as last amended by Directive .../.../EC.

Type-approval number:

Reason for extension:

SECTION I

- 0.1. Make (trade name of manufacturer):
- 0.2. Type and general commercial description(s):
- 0.3. Means of identification of type if marked on the vehicle/component/separate technical unit ⁽¹⁾ ⁽²⁾
 - 0.3.1. Location of that marking:
- 0.4. Category of vehicle ⁽³⁾:
- 0.5. Name and address of manufacturer:
- 0.7. In the case of components and separate technical units, location and method of affixing of the EC approval mark:
- 0.8. Address(es) of assembly plant(s)

SECTION II

1. Additional information (where applicable): See Addendum
2. Technical service responsible for carrying out the tests:
3. Date of test report:
4. Number of test report:
5. Remarks (if any): See Addendum
6. Place:
7. Date:
8. Signature:
9. The index to the information package lodged with the approval authority, which may be obtained on request, is attached.

Addendum to EC type-approval certificate No ...

concerning the type-approval of a vehicle with regard to Directive 70/157/EEC as last amended by Directive ...

1. Additional information:
 - 1.1. If necessary, list of vehicles covered by item 5.2.2.4.3.3.1.2. of Annex I:
 - 1.2. Engine
 - 1.2.1. Manufacturer:
 - 1.2.2. Type:
 - 1.2.3. Model:
 - 1.2.4. Rated maximum power kW at min⁻¹

⁽¹⁾ Delete where not applicable.⁽²⁾ If the means of identification of type contains characters not relevant to describe the vehicle, component or separate technical unit types covered by this type-approval certificate such characters shall be represented in the documentation by the symbol: "?" (e.g. ABC??123??).⁽³⁾ As defined in Annex II A to Directive 70/156/EEC.

▼ **M9**

1.3. Transmission: non-automatic gearbox/automatic gearbox ⁽¹⁾

1.3.1. Number of gears:

1.4. Equipment

1.4.1. Exhaust silencer

1.4.1.1. Manufacturer:

1.4.1.2. Model:

1.4.1.3. Type:..... in accordance with drawing No:

1.4.2. Intake silencer

1.4.2.1. Manufacturer:

1.4.2.2. Model:

1.4.2.3. Type: in accordance with drawing No:

1.5. Tyre size:

1.5.1. Description of tyre type used for type-approval testing:

1.6. Measurements

1.6.1. Sound level of moving vehicle:

Measurement results			
	Left-hand side dB (A) ⁽²⁾	Right-hand side dB (A) ⁽²⁾	Position of gear lever
first measurement			
second measurement			
third measurement			
fourth measurement			
Test result:		dB (A)/E ⁽³⁾	

1.6.2. Sound level of stationary vehicle:

	dB (A)	Engine speed
first measurement		
second measurement		
third measurement		
Test result		dB (A)/E ⁽³⁾

1.6.3. Sound level of compressed air noise:

Measurement results		
	Left-hand side dB (A) ⁽²⁾	Right-hand side dB (A) ⁽²⁾
first measurement		
second measurement		
third measurement		
fourth measurement		
Test result		dB (A)

5. Remarks:

⁽¹⁾ Delete where inapplicable.

⁽²⁾ The measurement values are given with the 1 dB (A) deduction in accordance with provisions of item 5.2.2.5.1. of Annex I.

⁽³⁾ 'E' indicates that the measurements in question were conducted in accordance with this Directive.

▼ M8*ANNEX II***EEC TYPE-APPROVAL OF EXHAUST SYSTEMS AS SEPARATE TECHNICAL UNITS (REPLACEMENT EXHAUST SYSTEMS)**

0. SCOPE

This Annex applies to the type-approval, as separate technical units within the meaning of ►M9 Article 2 ◀ of Directive 70/156/EEC, of exhaust systems or components thereof to be fitted to one or more given types of motor vehicle in categories M₁ and N₁ as replacement parts.

1. DEFINITIONS

- 1.1. Replacement exhaust system or component thereof means any part of the exhaust system defined in section 1.2.1 of Annex I intended to replace on a vehicle a part of the type granted EEC type-approval with the vehicle in accordance with Annex I.

2. APPLICATION FOR EEC TYPE-APPROVAL

▼ M9

- 2.1. The application of EC type-approval pursuant to Article 3 (4) of Directive 70/156/EEC in respect of a replacement exhaust system or component thereof as a separate technical unit shall be submitted by the vehicle manufacturer or the manufacturer of the separate technical unit in question.
- 2.2. A model for the information document is given in Appendix 1.

▼ M8

- 2.3. At the request of the technical service concerned, the applicant must submit:
- 2.3.1. — two examples of the system in respect of which application for EEC type-approval has been made,
- 2.3.2. — an exhaust system of the type originally fitted to the vehicle when EEC type-approval was granted,

▼ M10

- 2.3.3. — a vehicle representative of the type to which the system is to be fitted, which meets the requirements of item 4.1 of Annex III, part I,

▼ M8

- 2.3.4. — a separate engine corresponding to the type of vehicle described above.

▼ M9**▼ M8**

- M9 2.4. ◀ Markings
- M9 2.4.1. ◀ The replacement exhaust system or its components, excluding fixing hardware and pipes must bear:
- M9 2.4.1.1. ◀ — the trademark or trade name of the manufacturer of the replacement system and its components,
- M9 2.4.1.2. ◀ — the manufacturer's trade description,

▼ M9**▼ M8**

- M9 2.4.1.2. ◀ These marks must be clearly legible and indelible, even when the system is fitted to the vehicle.

▼ M9

3. GRANTING OF EC TYPE-APPROVAL
- 3.1. If the relevant requirements are satisfied, EC type-approval pursuant to Article 4 (3) and, if applicable, Article 4 (4) of Directive 70/156/EEC shall be granted.
- 3.2. A model for the EC type-approval certificate is given in Appendix 2.
- 3.3. A type-approval number in accordance with Annex VII to Directive 70/156/EEC shall be assigned to each type of replacement exhaust system or component thereof approved as a separate technical unit; section 3 of the type-approval number shall indicate the number of the amending Directive which was applicable at the time of the vehicle type-approval. The same Member State shall not assign the same number to another type of replacement exhaust system or component thereof.
4. EC TYPE-APPROVAL MARK
- 4.1. Every replacement exhaust system or component thereof, excluding fixing hardware and pipes, conforming to a type approved under this Directive shall bear an EC type-approval mark.
- 4.2. The EC type-approval mark shall consist of a rectangle surrounding the lower case letter 'e' followed by the distinguishing letter(s) or number of the Member State which has granted the approval:
- '1' for Germany
 - '2' for France
 - '3' for Italy
 - '4' for the Netherlands
 - '5' for Sweden
 - '6' for Belgium

▼ A4

- '7' for Hungary
- '8' for the Czech Republic

▼ M9

- '9' for Spain
- '11' for the United Kingdom
- '12' for Austria
- '13' for Luxembourg
- '17' for Finland
- '18' for Denmark

▼ A4

- '20' for Poland

▼ M9

- '21' for Portugal
- '23' for Greece

▼ A4

- '26' for Slovenia
- '27' for Slovakia
- '29' for Estonia
- '32' for Latvia
- '36' for Lithuania
- 'CY' for Cyprus

▼ M9

- 'IRL' for Ireland

▼ A4

- 'MT' for Malta

▼ M9

It must also include in the vicinity of the rectangle the 'base approval number' contained in section 4 of the type-approval number referred to in Annex VII to Directive 70/156/EEC,

▼ M9

preceded by the two figures indicating the sequence number assigned to the most recent major technical amendment to Council Directive 70/157/EEC which was applicable at the time of the vehicle type-approval. For Directive 70/157/EEC, the sequence number is 00; for Directive 77/212/EEC the sequence number is 01; for Directive 84/424/EEC the sequence number is 02; for Directive 92/97/EEC the sequence number is 03.

- 4.3. The mark must be clearly legible and indelible even when the replacement exhaust system or component thereof is fitted to the vehicle.
- 4.4. An example of the EC type-approval mark is shown in Appendix 3.

▼ M8

5. SPECIFICATIONS

5.1. **General specifications**

- 5.1.1. The replacement exhaust systems or component thereof must be designed, constructed and capable of being mounted so as to ensure that the vehicle complies with the provisions of this Directive under normal conditions of use, notwithstanding any vibrations to which it may be subject.
- 5.1.2. The exhaust system or components thereof must be designed, constructed and capable of being mounted so that reasonable resistance to the corrosion phenomena to which it/they is/are exposed is obtained having regard to the conditions of use of the vehicle.

▼ M10

- 5.1.3. Exhaust systems shall be carefully installed on the vehicle. In particular, it shall be checked that the complete exhaust system will not noticeably leak after installation.

▼ M85.2. **Specifications relating to sound levels**

- 5.2.1. The acoustic efficiency of the replacement exhaust system or component thereof must be checked using the methods described in sections 5.2.2.4 and 5.2.3.4 of Annex I ► **M9** ⁽¹⁾ ◀.

When the replacement exhaust system or component thereof is mounted on the vehicle referred to in section 2.3.3 of this Annex, the sound levels obtained using the two methods (stationary and moving vehicle) must satisfy one of the following conditions:

- 5.2.1.1. they must not exceed the values obtained when this type of vehicle was granted EEC type-approval;
- 5.2.1.2. they must not exceed the sound level values measured on the vehicle, referred to in 2.3.3, when this is fitted with an exhaust system of the same type as that fitted to the vehicle when EEC type-approval was granted.

5.3. **Measurement of vehicle performance**

- 5.3.1. The replacement exhaust system or components thereof must be such as to ensure that vehicle performance is comparable with that achieved with the original equipment exhaust system or component thereof.
- 5.3.2. The replacement exhaust system or, depending on the manufacturer's choice, the components of this system, must be compared with the original equipment exhaust system or components thereof, which are also in new condition, fitted in turn to the vehicle referred to in 2.3.3.
- 5.3.3. The check must take the form of a measurement of pressure loss under the conditions specified in 5.3.4.1 or 5.3.4.2. The

⁽¹⁾ As prescribed in the version of this Directive which was applicable to the type-approval of the vehicle.

▼ M8

value measured with the replacement exhaust system must not exceed the value measured with the original equipment system by more than 25 % under the conditions mentioned below.

5.3.4. *Test method*

5.3.4.1. Engine test method

The measurement must be conducted on the engine referred to in 2.3.4 coupled to a dynamometer.

With the throttle completely open, the bench must be so adjusted as to obtain the engine speed (S) corresponding to the rated maximum power of the engine.

For the measurement of back pressure, the pressure tap must be placed at the distance from the exhaust manifold specified in Figures 1, 2 and 3.

5.3.4.2. Vehicle test method

The measurements must be carried out on the vehicle referred to in item 2.3.3.

The test must be conducted:

- either on road,
- or
- on a roller dynamometer.

With the throttle completely open, the engine must be loaded so as to obtain the engine speed (S) corresponding to the rated maximum power.

For the measurement of back pressure, the pressure tap must be placed at the distance from the exhaust manifold specified in Figures 1, 2 and 3.

5.4. **Additional provisions in respect of exhaust systems or components thereof filled with fibrous materials**

Fibrous materials must not be used in the manufacture of replacement exhaust systems or components thereof unless appropriate measures are taken during the design and production stages to ensure that a level of efficiency is attained corresponding to the limits set out in section 5.2.2.1 of Annex I.

Such a silencing system is deemed to be effective in traffic if the exhaust gases are not in contact with the fibrous materials or if, after the removal of the fibrous materials, the sound levels comply with the requirements set out in 5.2.1, when the exhaust system is tested on a vehicle in accordance with the methods described in sections 5.2.2 and 5.2.3 of Annex I.

If this condition is not observed, the entire exhaust system must be subjected to conditioning. This must be done using one of the three methods described in sections 5.3.1.1, 5.3.1.2 and 5.3.1.3 of Annex I.

After conditioning, the sound level must be checked as specified in 5.2.1 above.

When the procedure described in item 5.2.1.2 is employed, the applicant for EEC type-approval may ask for the conditioning of the original equipment exhaust system or submit one which has been emptied.

▼ M9

6. MODIFICATION OF THE TYPE AND AMENDMENTS TO APPROVALS

6.1. In the case of modifications of the type approved pursuant to this Directive, the provisions of Article 5 of Directive 70/156/EEC shall apply.

▼M9

7. CONFORMITY OF PRODUCTION
- 7.1. Measures to ensure the conformity of production shall be taken in accordance with the requirements laid down in Article 10 to Directive 70/156/EEC.
- 7.2. Special provisions:
 - 7.2.1. The tests referred to item 2.3.5. of Annex X to Directive 70/156/EEC are those prescribed in Annex III (II) to this Directive.
 - 7.2.2. The frequency of inspections referred to in item 2.4. of Annex X to Directive 70/156/EEC is normally one every two years.

▼ M8

Back pressure — measuring points

Figure 1

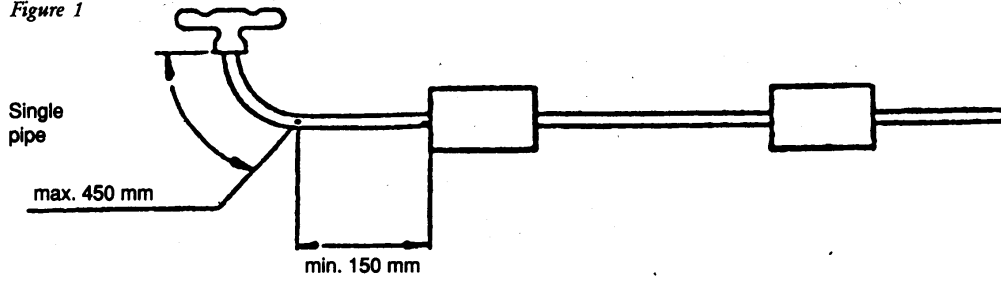

Figure 2 (*)

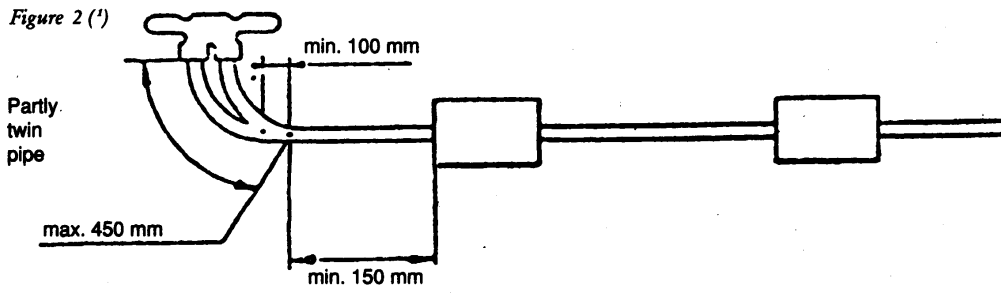
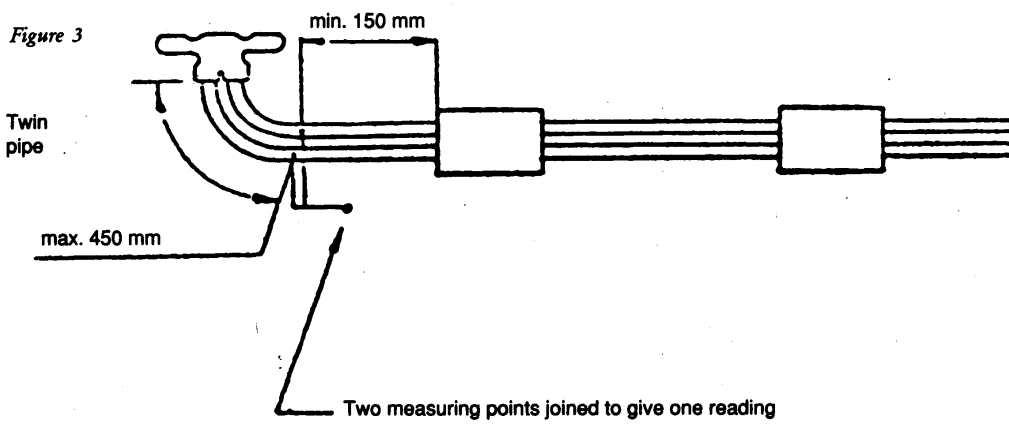

Figure 3



(*) If this is not possible, use Figure 3.

Appendix 1

Information Document No ... relating to EC type-approval as separate technical unit of exhaust systems for motor vehicles (Directive 70/157/EEC, as last amended by Directive .../.../EC)

The following information, if applicable, must be supplied in triplicate and include a list of contents. Any drawings must be supplied in appropriate scale and in sufficient detail on size A4 or on a folder of A4 format. Photographs, if any, must show sufficient detail.

If the systems, components or separate technical units have electronic controls, information concerning their performance must be supplied.

0. General

0.1. Make (trade name of manufacturer):

0.2. Type and general commercial description(s):

0.5. Name and address of manufacturer:

0.7. In the case of components and separate technical units, location and method of affixing of the EC approval mark:

0.8. Address(es) of assembly plant(s):

1. Description of the vehicle for which the device is intended (if the device is intended to be fitted to more than one vehicle type the information requested under this point shall be supplied for each type concerned)

1.1. Make (trade name of manufacturer):

1.2. Type and general commercial description(s):

1.3. Means of identification of type, if marked on the vehicle:

1.4. Category of vehicle:

1.5. EC type-approval number with regard to sound level:

1.6. All the information mentioned in items 1.1. to 1.5. of the type-approval certificate concerning the vehicle (Annex I, Appendix 2 to this Directive):

2. Description of the device

2.1. A description of the replacement exhaust system indicating the relative position of each system component, together with mounting instructions:

2.2. Detailed drawings of each component, so that they can be easily located and identified, and reference to the materials used. These drawings must indicate the place provided for the compulsory affixing of the EC type-approval mark:

Date, File

MODEL**EC TYPE-APPROVAL CERTIFICATE**

(Maximum Format: A4 (210 × 297 mm))

Stamp of administration

Communication concerning the

- type-approval (1)
- extension of type-approval (1)
- refusal of type-approval (1)
- withdrawal of type-approval (1)

of a type of a vehicle/component/separate technical unit (1) with regard to Directive .../.../EEC, as last amended by Directive .../.../EC.

Type-approval number:

Reason for extension:

SECTION I

- 0.1. Make (trade name of manufacturer):
- 0.2. Type and general commercial description(s):
- 0.3. Means of identification of type if marked on the vehicle/component/separate technical unit (1)(2):
 - 0.3.1. Location of that marking:
- 0.4. Category of vehicle (3)
- 0.5. Name and address of manufacturer:
- 0.7. In the case of components and separate technical units, location and method of affixing of the EC approval mark:
- 0.8. Address(es) of assembly plant(s):

SECTION II

1. Additional information (where applicable): See Addendum
2. Technical service responsible for carrying out the tests:
3. Date of test report:
4. Number of test report:
5. Remarks (if any): See Addendum
6. Place:
7. Date:
8. Signature:
9. The index to the information package lodged with the approval authority, which may be obtained on request, is attached.

Addendum to EC type-approval certificate No ...

concerning the separate technical unit type-approval of exhaust systems for motor vehicles with regard to Directive 70/157/EEC as last amended by Directive ...

1. Additional information
 - 1.1. Composition of the separate technical unit:

(1) Delete where not applicable.

(2) If the means of identification of type contains characters not relevant to describe the vehicle, component or separate technical unit types covered by the type-approval certificate such characters shall be represented in the documentation by the symbol: "?" (e.g. ABC??123??).

(3) As defined in Annex II A to Directive 70/156/EEC.

▼ M9

- 1.2. Trademark or trade name of the type(s) of motor vehicle to which the silencer is to be fitted (
 - 1.3. Type(s) of vehicle and its/their type-approval number(s):
 - 1.4. Engine
 - 1.4.1. Type (positive ignition, diesel):
 - 1.4.2. Cycles: two-stroke, four-stroke:
 - 1.4.3. Total cylinder capacity:
 - 1.4.4. Rated maximum engine power kW at min⁻¹
 - 1.5. Number of gear ratios:
 - 1.6. Gear ratios employed:
 - 1.7. Drive-axle ratios(s):
 - 1.8. Sound-level values:
 - moving vehicle: dB (A), speed stabilized before acceleration at km/h;
 - stationary vehicle: dB (A), at min⁻¹
 - 1.9. Variation in back pressure:
 - 1.10. Any restrictions in respect of use and mounting requirements:
5. Remarks:

(¹) If several types are indicated, items 1.3. to 1.10. inclusive must be completed in respect of each type.

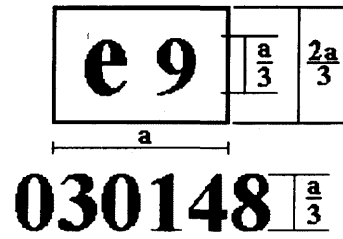
▼ M9*Appendix 3***MODEL FOR THE EC TYPE-APPROVAL MARK****a \geq 12 mm**

The exhaust system or component thereof bearing the above EC type-approval mark is a device which has been approved in Spain (e 9) pursuant to Directive 92/97/EEC (03) under the base approval number 0148.

The figures used are only indicative.

▼ M9▼ M8▶ M9 ANNEX III ◀**CHECKS ON CONFORMITY OF PRODUCTION****I. VEHICLES****1. General**

These requirements are consistent with the test to be held to check conformity of production, ▶ M10 pursuant to item 7 of Annex I ◀.

▼ M9**2. Testing procedures**

The methods of testing, conditions and measurements, measuring instruments and interpretation of results shall be those described in Annex I. The vehicle(s) under test shall be subject to the test for measurement of noise of vehicle in motion as described in item 5.2.2. of Annex I.

▼ M8**3. Sampling**

One vehicle has to be chosen. If after the test in 4.1 below the vehicle is not considered to conform to the requirements of this Directive, two more vehicles have to be tested.

4. Evaluation of the results

- 4.1. If the sound level of the vehicle tested pursuant to sections 1 and 2 does not exceed by more than 1 dB (A) the limit values prescribed in item 5.2.2.1 of Annex I, the vehicle type shall be considered to conform to the requirements of this Directive.
- 4.2. If the vehicle tested according to 4.1 does not satisfy the requirements laid down in that section, two more vehicles of the same type must be tested pursuant to sections 1 and 2.
- 4.3. If the sound level of the second and/or third vehicle of 4.2 exceeds by more than 1 dB (A) the limit values prescribed in section 5.2.2.1 of Annex I, the vehicle type is considered not to conform to the requirements of this Directive and the manufacturer must take the necessary measures to restore the conformity.

II. REPLACEMENT EXHAUST SYSTEMS**1. General**

These requirements are consistent with the test to be held to check conformity of production, ▶ M10 pursuant to item 7 of Annex II ◀.

2. Testing procedures

The methods of testing, measuring instruments and interpretation of results are those described in Annex II. The exhaust system or component under test must be subjected to the test as described in Annex II, section 5.

3. Sampling

An exhaust system or component has to be chosen. If, after the test in 4.1, the sample is not considered to conform to the requirements of this Directive, two more samples have to be tested.

4. Evaluation of the results

- 4.1. If the sound level of the exhaust system or component, tested pursuant to sections 1 and 2, measured in accordance with section 5.2 of Annex II, does not exceed by more than 1 dB (A) the level measured during the EEC type-approval tests of this type of exhaust system or component, the exhaust system or component type is considered to conform to the requirements of this Directive.
- 4.2. If the exhaust system or component tested according to 4.1 does not satisfy the requirements laid down in that section, two more exhaust systems or

▼ M8

components of the same type must be tested pursuant to sections 1 and 2 above.

- 4.3. If the sound level of the second and/or third sample of 4.2 exceeds by more than 1 dB (A) the level measured during the EEC type-approval tests of this type of exhaust system or component, the exhaust system or component type is considered not to conform to the requirements of this Directive and the manufacturer must take the necessary measures to restore the conformity.

▼ **M8**► **M9** ANNEX IV ◀**TEST TRACK SPECIFICATIONS**

This Annex lays down specifications relating to the physical characteristics of the paving and the layout of the test track paving.

1. **REQUIRED CHARACTERISTICS OF THE SURFACE**

A surface is considered to conform to this Directive provided that the texture and voids content or sound absorption coefficient have been measured and found to fulfill all the requirements given in 1.1 to 1.4 and provided that the design requirements (Section 2.2) have been met.

1.1. **Residual voids content**

The residual voids content, V_c , of the test track paving mixture shall not exceed 8 %. See section 3.1 for measurement procedure.

1.2. **Sound absorption coefficient**

If the surface fails to comply with the residual voids content requirement, the surface is acceptable only if its sound absorption coefficient, α , is $\leq 0,10$. See section 3.2 for measurement procedure.

The requirement of section 1.1. and 1.2. is met also if only sound absorption has been measured and found to be: $\alpha \leq 0,10$.

1.3. **Texture depth**

The texture depth (TD) measured according to the volumetric method (see section 3.3) shall be:

$$TD \geq 0,4 \text{ mm.}$$

1.4. **Homogeneity of the surface**

Every practical effort shall be taken to ensure that the surface is made to be as homogenous as possible within the test area. This includes the texture and voids content, but it should also be observed that if the rolling process results in more effective rolling at some places than at others, the texture may be different and unevenness causing bumps may also occur.

1.5. **Period of testing**

In order to check whether the surface continues to conform to the texture and voids content or sound absorption requirements stipulated in this standard, periodic testing of the surface shall be done at the following intervals:

(a) for residual voids content or sound absorption:

- when the surface is new,
- if the surface meets the requirement when new, no further periodical testing is required.

If it does not meet the requirement when it is new, it may do so later because surfaces tend to become clogged and compacted with time;

(b) for texture depth (TD):

- when the surface is new,
- when the noise testing starts (NB: not before four weeks after laying),
- then every twelve months.

2. **TEST SURFACE DESIGN**2.1. **Area**

When designing the test track layout it is important to ensure that, as a minimum requirement, the area traversed by the vehicles running through the test strip is covered with the specified test material with suitable margins for safe and practical driving. This will require that the width of the track is at least 3 m and the length of the track

▼ M8

extends beyond lines AA and BB by at least 10 m at either end. Figure 1 shows a plan of a suitable test site and indicates the minimum area which shall be machine laid and machine compacted with the specified test surface material.

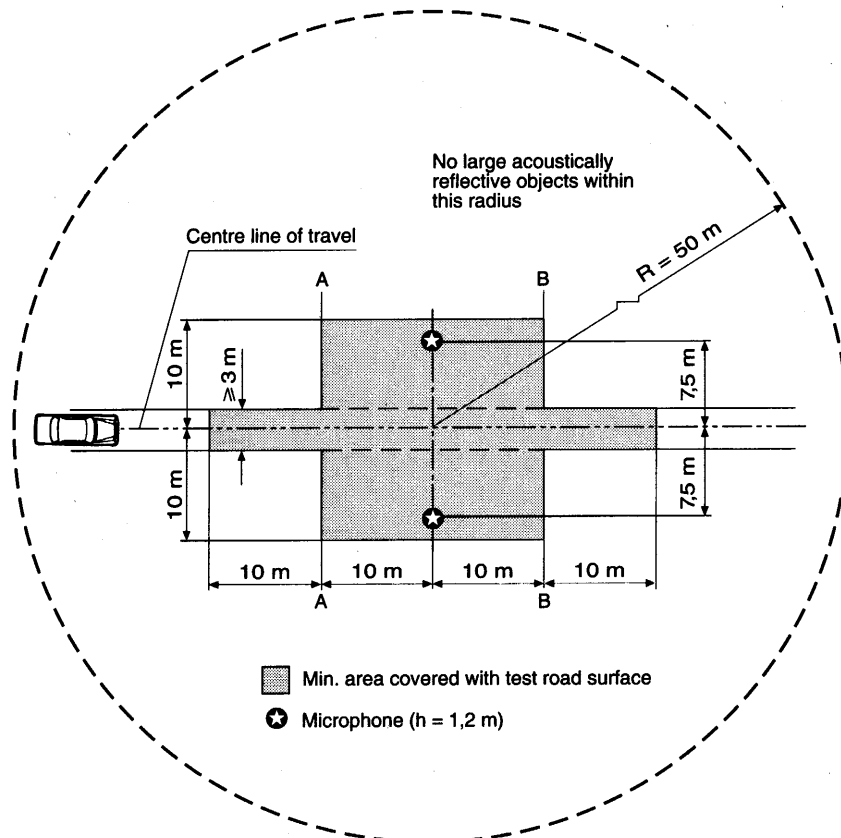

Figure 1

Minimum requirements for test surface area

The shaded part is called 'test area'

2.2. **Design requirements for the surface**

The test surface shall meet four design requirements:

1. it shall be a dense asphaltic concrete;
2. the maximum chipping size shall be 8 mm (tolerances allow from 6,3 to 10 mm);
3. the thickness of the wearing course shall be ≥ 30 mm;
4. the binder shall be a straight penetration grade bitumen without modification.

As a guide to the test surface constructor, an aggregate grading curve which will give desired characteristics is shown in figure 2. In addition, table 3 gives some guidelines in order to obtain the desired texture and durability. The grading curve fits the following formula:

$$P (\% \text{ passing}) = 100 (d/d_{\max})^{1/2}$$

where

- d = square mesh sieve size, in mm
- d_{\max} = 8 mm for the mean curve
- d_{\max} = 10 mm for the lower tolerance curve
- d_{\max} = 6,3 mm for the upper tolerance curve

In addition to the above, the following recommendations are given:

- the sand fraction ($0,063 \text{ mm} < \text{square mesh sieve size} < 2 \text{ mm}$) shall include no more than 55 % natural sand and at least 45 % crushed sand,
- the base and sub-base shall ensure a good stability and evenness, according to best road construction practice,

▼ **M8**

- the chippings shall be crushed (100 % crushed faces) and of a material with a high resistance to crushing,
- the chippings used in the mix shall be washed,
- no extra chippings shall be added on to the surface,
- the binder hardness expressed as PEN value shall be 40 to 60, 60 to 80 or even 80 to 100, depending on the climatic conditions of the country. The rule is that as hard a binder as possible shall be used, provided this is consistent with common practice,
- the temperature of the mix before rolling shall be chosen so as to achieve by subsequent rolling the required voids content. In order to increase the probability of satisfying the specifications of sections 1.1 to 1.4, the compactness shall be studied not only by an appropriate choice of mixing temperature, but also by an appropriate number of passings and by the choice of compacting vehicle.

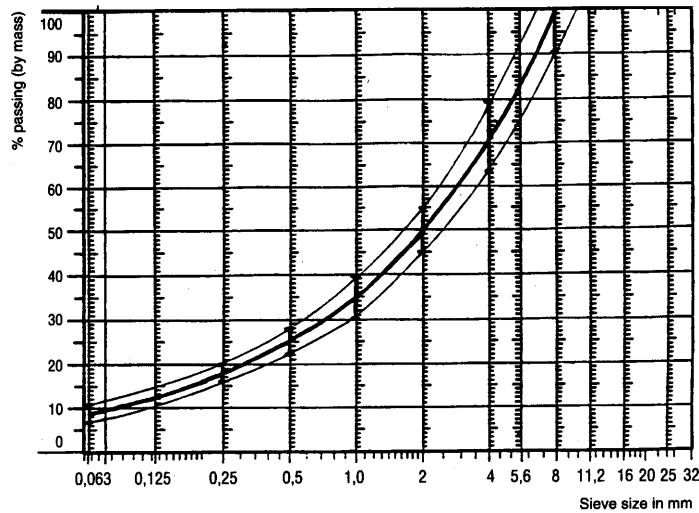

Figure 2

Grading curve of the aggregate in the asphaltic mix, with tolerances

Table 3

Design guidelines

	Target values		Tolerances
	By total mass of mix	By mass of the aggregate	
Mass of stones, Square Mesh Sieve (SM) > 2 mm	47,6 %	50,5 %	±5
Mass of sand 0,063 < SM < 2 mm	38,0 %	40,2 %	±5
Mass of filler SM < 0,063 mm	8,8 %	9,3 %	±2
Mass of binder (bitumen)	5,8 %	N.A.	±0,5
Maximum chipping size	8 mm		6,3—10
Binder hardness	(see below)		
Polished stone value (PSV) (see doc. 5 in bibliography)	> 50		
Compactness, relative to Marshall compactness	98 %		

▼ **M8**

3. TEST METHODS

3.1. **Measurement of the residual voids content**

For the purpose of this measurement, cores have to be taken from the track at least at four different positions which are equally distributed in the test area between lines AA and BB (see figure 1). In order to avoid inhomogeneity and unevenness in the wheel tracks, cores should not be taken in the wheel tracks themselves, but close to them. Two cores (minimum) should be taken close to the wheel tracks and one core (minimum) should be taken approximately midway between the wheel tracks and each microphone location.

If there is a suspicion that the condition of homogeneity is not met (see section 1.4), cores shall be taken from more locations within the test area.

The residual voids content has to be determined for each core. Then the average value from all cores shall be calculated and compared with the requirement of section 1.1. In addition, no single core shall have a voids value which is higher than 10 %.

The test surface constructor is reminded of the problem which may arise when the test area is heated by pipes or electrical wires and cores must be taken from this area. Such installations must be carefully planned with respect to future core drilling locations. It is recommended to leave a few locations of size approximately 200 × 300 mm where there are no wires or pipes, or where the latter are located deep enough in order not to be damaged by cores taken from the surface layer.

3.2. **Sound absorption coefficient**

The sound absorption coefficient (normal incidence) shall be measured by the impedance tube method using the procedure specified in ISO/DIS 10534: 'Acoustics — Determination of sound absorption coefficient and impedance by a tube method'.

Regarding test specimens, the same requirements shall be followed as regarding the residual voids content (see section 3.1).

The sound absorption shall be measured in the range 400 to 800 Hz and in the range 800 to 1 600 Hz (at least at the centre frequencies of third octave bands) and the maximum values shall be identified for both of these frequency ranges. Then these values, for all test cores, shall be averaged to constitute the final result.

3.3. **Volumetric macrotexture measurement**

For the purposes of this standard, texture depth measurements shall be made on at least 10 positions evenly spaced along the wheel tracks of the test strip and the average value taken to compare with the specified minimum texture depth. See Annex F to Draft Standard ISO/DIS 10844 for a description of the procedure.

4. STABILITY IN TIME AND MAINTENANCE

4.1. **Age influence**

In common with many other surfaces, it is expected that the tyre/road noise levels measured on the test surface may increase slightly during the first six to 12 months after construction.

The surface will achieve its required characteristics not earlier than four weeks after construction. The influence of age on the noise from trucks is generally less than that from cars.

The stability over time is determined mainly by the polishing and compaction by vehicles driving on the surface. It shall be periodically checked as stated in section 1.5.

4.2. **Maintenance of the surface**

Loose debris or dust which could significantly reduce the effective texture depth must be removed from the surface. In countries with winter climates, salt is sometimes used for de-icing. Salt may alter the surface temporarily or even permanently in such a way as to increase noise and is therefore not recommended.

▼ M8**4.3. Repaving the test area**

If it is necessary to repave the test track, it is usually unnecessary to repave more than the test strip (of 3 m width in figure 1) where vehicles are driving provided the test area outside the strip met the requirement of residual voids content or sound absorption when it was measured.

5. DOCUMENTATION OF THE SURFACE AND OF TESTS PERFORMED ON IT**5.1. Documentation of the test surface**

The following data shall be given in a document describing the test surface:

- (a) the location of the test track;
- (b) type of binder, binder hardness, type of aggregate, maximum theoretical density of the concrete ('DR'), thickness of the wearing course and grading curve determined from cores from the test track;
- (c) method of compaction (e.g. type of roller, roller mass, number of passes);
- (d) temperature of the mix, temperature of the ambient air and wind speed during laying of the surface;
- (e) date when the surface was laid and contractor;
- (f) all or at least the latest test result, including:
 - (i) the residual voids content of each core;
 - (ii) the locations in the test area from where the cores for voids measurement have been taken;
 - (iii) the sound absorption coefficient of each core (if measured). Specify the results both for each core and each frequency range as well as the overall average;
 - (iv) the locations in the test area from where the cores for absorption measurement have been taken;
 - (v) texture depth, including the number of tests and standard deviation;
 - (vi) the institution responsible for tests (i) and (iii) and the type of equipment used;
 - (vii) date of the test(s) and date when the cores were taken from the test track.

5.2. Documentation of vehicle noise tests conducted on the surface

In the document describing the vehicle noise test(s) it shall be stated whether all the requirements were fulfilled or not. Reference shall be given to a document according to section 5.1.