

Commission Implementing Decision of 10 March 2014 on the approval of the light emitting diodes low beam module 'E-Light' as an innovative technology for reducing CO<sub>2</sub> emissions from passenger cars pursuant to Regulation (EC) No 443/2009 of the European Parliament and of the Council (Text with EEA relevance) (2014/128/EU)

## COMMISSION IMPLEMENTING DECISION

of 10 March 2014

on the approval of the light emitting diodes low beam module 'E-Light' as an innovative technology for reducing CO<sub>2</sub> emissions from passenger cars pursuant to Regulation (EC) No 443/2009 of the European Parliament and of the Council

(Text with EEA relevance)

(2014/128/EU)

THE EUROPEAN COMMISSION,

Having regard to the Treaty on the Functioning of the European Union,

Having regard to Regulation (EC) No 443/2009 of the European Parliament and of the Council of 23 April 2009 setting emissions performance standards for new passenger cars as part of the Community's integrated approach to reduce CO<sub>2</sub> emissions from light-duty vehicles<sup>(1)</sup>, and in particular Article 12(4) thereof,

Whereas:

- (1) The supplier Automotive Lighting Reutlingen GmbH (the 'Applicant') submitted an application for the approval of the light emitting diodes (LEDs) low beam module, 'E-Light', as an innovative technology on 9 July 2013. The completeness of the application was assessed in accordance with Article 4 of Commission Implementing Regulation (EU) No 725/2011<sup>(2)</sup>. The application was found to be complete and the period for the Commission's assessment of the application started on the day following the date of official receipt, i.e. 10 July 2013.
- (2) The application has been assessed in accordance with Article 12 of Regulation (EC) No 443/2009, Implementing Regulation (EU) No 725/2011 and the Technical Guidelines for the preparation of applications for the approval of innovative technologies pursuant to Regulation (EC) No 443/2009 (the Technical Guidelines)<sup>(3)</sup>.
- (3) The application refers to the LED low beam module 'E-Light', which is a lighting technology based on a so called refraction-reflection system. The E-Light module uses the reflection and refraction of light through lenses to concentrate the light produced by small number of LED lamps. This technology is significantly different from the LED lighting system approved as an eco-innovation in Commission Implementing Decision 2013/128/EU<sup>(4)</sup>. It should also be noted that the application by Automotive Lighting is based on the simplified approach described in the Technical Guidelines, whereas the previously approved application was based on the comprehensive approach.

---

**Changes to legislation:** There are outstanding changes not yet made to Commission Implementing Decision of 10 March 2014 on the approval of the light emitting diodes low beam module 'E-Light' as an innovative technology for reducing CO<sub>2</sub> emissions from passenger cars pursuant to Regulation (EC) No 443/2009 of the European Parliament and of the Council (Text with EEA relevance) (2014/128/EU). Any changes that have already been made to the legislation appear in the content and are referenced with annotations. (See end of Document for details) View outstanding changes

---

- (4) The Commission finds that the information provided in the application demonstrates that the conditions and criteria referred to in Article 12 of Regulation (EC) No 443/2009 and in Articles 2 and 4 of Implementing Regulation (EU) No 725/2011 have been met.
- (5) The Applicant has demonstrated that the use of the E-Light module in passenger cars did not exceed 3 % of the new passenger cars registered in the reference year 2009. In support of this the Applicant has referred to the Technical Guidelines, which provides for the summary of the CLEPA LIGHT Sight Safety report. The Applicant has used predefined functions and averaged data in line with the simplified approach specified in the Technical Guidelines.
- (6) The Applicant has in accordance with the simplified approach described in the Technical Guidelines used halogen lighting as baseline technology for demonstrating the CO<sub>2</sub> reducing capacity of the 'E-Light' module.
- (7) The Applicant has provided a methodology for testing the CO<sub>2</sub> reductions which includes formulae that are consistent with the formulae described in the Technical Guidelines for the simplified approach with regard to lighting functions. The Commission considers that the testing methodology will provide testing results that are verifiable, repeatable and comparable and that it is capable of demonstrating in a realistic manner the CO<sub>2</sub> emissions benefits of the innovative technology with strong statistical significance in accordance with Article 6 of Implementing Regulation (EU) No 725/2011.
- (8) Against that background the Commission finds that the Applicant has demonstrated satisfactorily that the emission reduction achieved by the innovative technology is at least 1 g CO<sub>2</sub>/km.
- (9) Since the activation of the lighting in the low beam is not required for the CO<sub>2</sub> emissions type approval test referred to in Regulation (EC) No 715/2007 of the European Parliament and of the Council<sup>(5)</sup> and Commission Regulation (EC) No 692/2008<sup>(6)</sup>, the Commission is satisfied that the lighting functions in question are not covered by the standard test cycle.
- (10) The activation of the lighting functions concerned is mandatory to ensure the safe operation of the vehicle and as a consequence not dependant on the choice of the driver. On that basis the Commission finds that the manufacturer should be considered accountable for the CO<sub>2</sub> emission reduction due to the use of the LEDs.
- (11) The Commission finds that the verification report has been prepared by FAKT S.r.l. which is an independent and certified body and that the report supports the findings set out in the application.
- (12) Against that background, the Commission finds that no objections should be raised as regards the approval of the innovative technology in question.
- (13) Any manufacturer wishing to benefit from a reduction of its average specific CO<sub>2</sub> emissions for the purpose of meeting its specific emissions target by means of the CO<sub>2</sub> savings from the use of the innovative technology approved by this Decision, should in accordance with Article 11(1) of Implementing Regulation (EU) No 725/2011, refer

---

**Changes to legislation:** There are outstanding changes not yet made to Commission Implementing Decision of 10 March 2014 on the approval of the light emitting diodes low beam module 'E-Light' as an innovative technology for reducing CO<sub>2</sub> emissions from passenger cars pursuant to Regulation (EC) No 443/2009 of the European Parliament and of the Council (Text with EEA relevance) (2014/128/EU). Any changes that have already been made to the legislation appear in the content and are referenced with annotations. (See end of Document for details) View outstanding changes

---

to this Decision in its application for an EC type-approval certificate for the vehicles concerned,

HAS ADOPTED THIS DECISION:

*Article 1*

1 The LED low beam module 'E-Light' intended for use in M1 vehicles is approved as an innovative technology within the meaning of Article 12 of Regulation (EC) No 443/2009.

2 The CO<sub>2</sub> emissions reduction from the use of the LED low beam module 'E-Light' referred to in paragraph 1 shall be determined using the methodology set out in the Annex.

*Article 2*

This Decision shall enter into force on the 20th day following that of its publication in the *Official Journal of the European Union*.

Done at Brussels, 10 March 2014.

*For the Commission*

*The President*

José Manuel BARROSO

**Changes to legislation:** There are outstanding changes not yet made to Commission Implementing Decision of 10 March 2014 on the approval of the light emitting diodes low beam module 'E-Light' as an innovative technology for reducing CO<sub>2</sub> emissions from passenger cars pursuant to Regulation (EC) No 443/2009 of the European Parliament and of the Council (Text with EEA relevance) (2014/128/EU). Any changes that have already been made to the legislation appear in the content and are referenced with annotations. (See end of Document for details) View outstanding changes

## ANNEX

### METHODOLOGY FOR DETERMINING THE REDUCTION IN CO<sub>2</sub> EMISSIONS DUE TO THE USE OF THE LED LOW BEAM MODULE E-LIGHT, IN AN M1 VEHICLE

#### 1. Introduction

In order to determine the CO<sub>2</sub> reductions that can be attributed to the use of the LEDs in Low Beam module, named E-Light, in an M1 vehicle, it is necessary to establish the following:

- (a) the testing conditions;
- (b) the test procedure;
- (c) the formulae for calculating the CO<sub>2</sub> savings;
- (d) the formulae for calculating the standard deviation;
- (e) the determination of the CO<sub>2</sub> savings for the certification by type approval authorities.

#### 2. Testing conditions

The requirements of UN/ECE Regulation No 112<sup>(7)</sup> on Uniform provisions concerning the approval of motor vehicle headlamps emitting an asymmetrical passing beam or a driving beam or both and equipped with filament lamps and/or light-emitting diode (LED) modules shall apply. For determining the power consumption, the reference is to be made to point 6.1.4 of Regulation No 112, and points 3.2.1 and 3.2.2 of Annex 10 to Regulation No 112.

In addition, a warming-up of the equipment under test (EUT) during 30 minutes shall take place by delivering a current of 0,78 A to the EUT, with a voltage of 13,4 V. The EUT consists of the electronic control unit (ECU) of the LED lamp and the low beam module.

#### 3. The testing procedure

Measurements are to be performed as shown in the figure. The following equipment is to be used:

- Two Digital Multi Meters, one for measuring the DC-current, and the other for measuring the DC-voltage.
- A power supply unit.

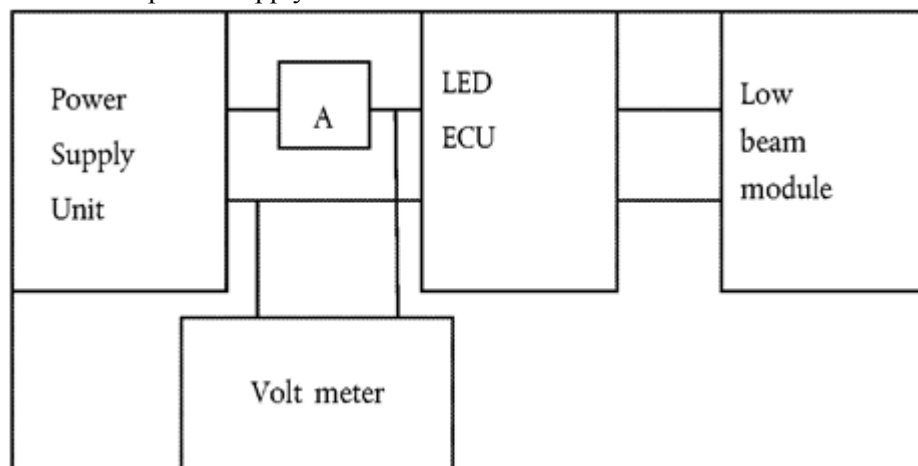

---

**Changes to legislation:** There are outstanding changes not yet made to Commission Implementing Decision of 10 March 2014 on the approval of the light emitting diodes low beam module 'E-Light' as an innovative technology for reducing CO<sub>2</sub> emissions from passenger cars pursuant to Regulation (EC) No 443/2009 of the European Parliament and of the Council (Text with EEA relevance) (2014/128/EU). Any changes that have already been made to the legislation appear in the content and are referenced with annotations. (See end of Document for details) View outstanding changes

---

In total ten measurements is to be done with the following voltages: 9,0 V; 10,0 V; 11,0 V; 12,0 V; 13,0 V; 13,2 V; 13,4 V; 14,0 V; 15,0 V; 16,0 V (where values of 13,2 V and 13,4 V are typical values for the voltages in passenger's vehicles).

For each voltage the current is to be measured respectively.

The exact installed voltages and the measured current is to be recorded in four decimals.

#### 4. Formulae

The following steps are to be taken to determine the CO<sub>2</sub> savings and to determine whether the threshold value of 1 g CO<sub>2</sub>/km is met:

- Step 1 : Calculate the power savings;
- Step 2 : Calculate the CO<sub>2</sub> savings;
- Step 3 : Calculate the error in the CO<sub>2</sub> savings;
- Step 4 : Verify the threshold value.

##### 4.1. Calculate the power savings

For each of the 10 measurements the power which is used is to be calculated by multiplying the installed voltage with the measured current. This is to result in 10 values. Each value is to be expressed in four decimals. Then the mean value of the used power is to be calculated, which is the sum of the 10 values for the power divided by 10.

The resulting power savings are to be calculated with the following formula:

Formula (1)

$$\Delta P = P_{\text{baseline}} - P_{\text{eco-innovation}}$$

Where:

- $\Delta P$  : Power savings in W;
- $P_{\text{baseline}}$  : Power of the baseline, which is 137 W;
- $P_{\text{eco-innovation}}$  : Mean value of the used power of the eco-innovation in W.

##### 4.2. Calculate the CO<sub>2</sub> savings

The formulae to calculate the CO<sub>2</sub> savings of the eco-innovation are:

For a petrol-fuelled vehicle:

Formula (2)

$$C_{\text{CO}_2} = \Delta P \times UF \times V_{\text{Pe-P}} / \eta_A \times CF_P / v$$

For a diesel-fuelled vehicle:

Formula (3)

$$C_{\text{CO}_2} = \Delta P \times UF \times V_{\text{Pe-D}} / \eta_A \times CF_D / v$$

Where in these formulae CO<sub>2</sub> is the CO<sub>2</sub> savings in g CO<sub>2</sub>/km.

The input data for the formulae (2) and (3) are:

- $\Delta P$  : Saved electrical power in W, which is the result of step 1
- UF : Usage factor which is 0,33 for a low beam lamp
- v : mean driving speed of the NEDC, which is 33,58 km/h
- $V_{\text{Pe-P}}$  : consumption of effective power for petrol-fuelled vehicles, which is 0,264 l/kWh

**Changes to legislation:** There are outstanding changes not yet made to Commission Implementing Decision of 10 March 2014 on the approval of the light emitting diodes low beam module 'E-Light' as an innovative technology for reducing CO<sub>2</sub> emissions from passenger cars pursuant to Regulation (EC) No 443/2009 of the European Parliament and of the Council (Text with EEA relevance) (2014/128/EU). Any changes that have already been made to the legislation appear in the content and are referenced with annotations. (See end of Document for details) View outstanding changes

$V_{Pe-D}$	: consumption of effective power for diesel-fuelled vehicles, which is 0,22 1/kWh
$\eta_A$	: efficiency of the alternator, which is 0,67
$CF_P$	: conversion factor for petrol fuel, which is 2 330 g CO <sub>2</sub> /l
$CF_D$	: conversion factor for diesel fuel, which is 2 640 g CO <sub>2</sub> /l

#### 4.3. Calculate the statistical error in the CO<sub>2</sub> savings

The statistical error in the CO<sub>2</sub> savings is to be determined in two steps. In the first step the error value of the power is to be determined as a standard deviation being equivalent to a confidence interval of 68 %.

This is to be done by formula (4).

Formula (4)

$$s_{\bar{x}} = \sqrt{\frac{\sum_{i=1}^n (x_i - \bar{x})^2}{n(n-1)}}$$

Where:

$s_{\bar{x}}$	: standard deviation of arithmetic mean [W];
$x_i$	: measurement value [W];
$\bar{x}$	: arithmetic mean [W];
$n$	: number of measurements, which is 10.

Then the error in the CO<sub>2</sub> savings is to be determined using the propagation law, which is expressed in formula (5).

Formula (5)

$$\Delta \bar{C}_{CO_2} = \sqrt{\sum_{i=1}^n \left( \frac{\partial C_{CO_2}}{\partial P} \times eP_i \right)^2}$$

Where:

$\Delta C_{CO_2}$ :	mean total error of the CO <sub>2</sub> saving (gCO <sub>2</sub> /km)
$\partial C_{CO_2}/\partial P$	sensitivity of calculated CO <sub>2</sub> saving related to input value $x_i$
$eP_i$ :	error of input value (W)

Substituting formula (2) in formula (5) leads for petrol fueled vehicles to:

Formula (6)

$$\Delta C_{CO_2} = 0,0090 \text{ gCO}_2 / \text{kmW} \times eP$$

Where:

$\Delta C_{CO_2}$	: the error in the CO <sub>2</sub> savings (g CO <sub>2</sub> /km);
$eP$	: the error in the power consumption (W).

Substituting formula (2) in formula (5) leads for diesel fueled vehicles to:

Formula (7)

$$\Delta C_{CO_2} = 0,0085 \text{ gCO}_2 / \text{kmW} \times eP$$

Where:

$\Delta C_{CO_2}$	: the error in the CO <sub>2</sub> savings (g CO <sub>2</sub> /km);
$eP$	: error in the power consumption (W).

---

**Changes to legislation:** There are outstanding changes not yet made to Commission Implementing Decision of 10 March 2014 on the approval of the light emitting diodes low beam module 'E-Light' as an innovative technology for reducing CO<sub>2</sub> emissions from passenger cars pursuant to Regulation (EC) No 443/2009 of the European Parliament and of the Council (Text with EEA relevance) (2014/128/EU). Any changes that have already been made to the legislation appear in the content and are referenced with annotations. (See end of Document for details) View outstanding changes

---

#### 4.4. Verify the threshold value

By means of formula (8) the threshold value is verified. The minimum threshold value is 1,0 g CO<sub>2</sub>/km.

Formula (8):

$$MT \leq C_{CO_2} - \Delta \bar{C}_{CO_2}$$

Where:

MT : minimum threshold (g CO<sub>2</sub>/km)  
 C<sub>CO<sub>2</sub></sub> : total CO<sub>2</sub> saving (g CO<sub>2</sub>/km), which must be expressed in 4 decimals,  
 Δ $\bar{C}_{CO_2}$  : mean total error of the CO<sub>2</sub> saving (g CO<sub>2</sub>/km), which must be expressed in 4 decimals.

#### 5. Eco-innovation code to be entered into type approval documentation

For the purposes of determining the general eco-innovation code to be used in the relevant type approval documents in accordance with Annexes I, VIII and IX to Directive 2007/46/EC of the European Parliament and of the Council<sup>(8)</sup>, the individual code to be used for the innovative technology approved through this Decision shall be '5'.

E.g. the code of the eco-innovation in the case of eco-innovation savings certified by the German type approval authority shall be 'e1 5'.

---

**Changes to legislation:** There are outstanding changes not yet made to Commission Implementing Decision of 10 March 2014 on the approval of the light emitting diodes low beam module 'E-Light' as an innovative technology for reducing CO<sub>2</sub> emissions from passenger cars pursuant to Regulation (EC) No 443/2009 of the European Parliament and of the Council (Text with EEA relevance) (2014/128/EU). Any changes that have already been made to the legislation appear in the content and are referenced with annotations. (See end of Document for details) View outstanding changes

---

- (1) [OJ L 140, 5.6.2009, p. 1.](#)
- (2) Commission Implementing Regulation (EU) No 725/2011 of 25 July 2011 establishing a procedure for the approval and certification of innovative technologies for reducing CO<sub>2</sub> emissions from passenger cars ([OJ L 194, 26.7.2011, p. 19](#)).
- (3) [http://ec.europa.eu/clima/policies/transport/vehicles/cars/docs/guidelines\\_en.pdf](http://ec.europa.eu/clima/policies/transport/vehicles/cars/docs/guidelines_en.pdf)
- (4) Commission Implementing Decision 2013/128/EU of 13 March 2013 on the approval of the use of light emitting diodes in certain lighting functions of an M1 vehicle as an innovative technology for reducing CO<sub>2</sub> emissions from passenger cars pursuant to Regulation (EC) No 443/2009 of the European Parliament and of the Council ([OJ L 70, 14.3.2013, p. 7](#)).
- (5) Regulation (EC) No 715/2007 of the European Parliament and of the Council of 20 June 2007 on type approval of motor vehicles with respect to emissions from light passenger and commercial vehicles (Euro 5 and Euro 6) and on access to vehicle repair and maintenance information ([OJ L 171, 29.6.2007, p. 1](#)).
- (6) Commission Regulation (EC) No 692/2008 of 18 July 2008 implementing and amending Regulation (EC) No 715/2007 of the European Parliament and of the Council on type-approval of motor vehicles with respect to emissions from light passenger and commercial vehicles (Euro 5 and Euro 6) and on access to vehicle repair and maintenance information ([OJ L 199, 28.7.2008, p. 1](#)).
- (7) E/ECE/324/Rev.2/Add.111/Rev.3 – E/ECE/TRANS/505/Rev.2/Add.111/Rev.3, 9 January 2013.
- (8) Directive 2007/46/EC of the European Parliament and of the Council of 5 September 2007 establishing a framework for the approval of motor vehicles and their trailers, and of systems, components and separate technical units intended for such vehicles (Framework Directive) ([OJ L 263, 9.10.2007, p. 1](#)).



**Changes to legislation:**

There are outstanding changes not yet made to Commission Implementing Decision of 10 March 2014 on the approval of the light emitting diodes low beam module 'E-Light' as an innovative technology for reducing CO2 emissions from passenger cars pursuant to Regulation (EC) No 443/2009 of the European Parliament and of the Council (Text with EEA relevance) (2014/128/EU). Any changes that have already been made to the legislation appear in the content and are referenced with annotations.

[View outstanding changes](#)

**Changes and effects yet to be applied to :**

- Art. 2 omitted by [S.I. 2019/550 reg. 10\(2\)](#)

**Changes and effects yet to be applied to the whole legislation item and associated provisions**

- Annex para. 5 words omitted by [S.I. 2019/550 reg. 10\(3\)](#)