

Commission Decision of 10 February 2011 amending Decision 2007/756/EC adopting a common specification of the national vehicle register (notified under document C(2011) 665) (Text with EEA relevance) (2011/107/EU)

COMMISSION DECISION

of 10 February 2011

amending Decision 2007/756/EC adopting a common specification of the national vehicle register

(notified under document C(2011) 665)

(Text with EEA relevance)

(2011/107/EU)

THE EUROPEAN COMMISSION,

Having regard to the Treaty on the Functioning of the European Union,

Having regard to Directive 2008/57/EC of the European Parliament and of the Council of 17 June 2008 on the interoperability of the rail system within the Community<sup>(1)</sup>, and in particular Article 33 thereof,

Whereas:

- (1) Section 2.2 of the Annex to Commission Decision 2007/756/EC of 9 November 2007 adopting a common specification of the national vehicle register provided for pursuant to Article 14(4) and (5) of Directives 96/48/EC and 2001/16/EC<sup>(2)</sup> describes the implementation of the European global architecture for national vehicle registers (NVRs) and provides for an update of the Decision, if appropriate, following the evaluation of a pilot project by the European Railway Agency. Moreover, it provides for a decision to connect national vehicle registers to the central Virtual Vehicle Register (VVR). The European Railway Agency has implemented and evaluated the pilot project. On 26 March 2010, it delivered to the Commission recommendation ERA/REC/01-2010/INT proposing an update of the Annex to Decision 2007/756/EC. Decision 2007/756/EC should therefore be amended.
- (2) Article 33(2) of Directive 2008/57/EC provides that the NVR is to contain, among other compulsory information, the identification of the owner of the vehicle and the entity in charge of maintenance. A transition period is therefore needed for adapting non-standard NVRs to contain Field 9.2 'registered business number' and updating the information on the owner and entity in charge of maintenance for vehicles already registered in the NVR.
- (3) The transition periods for existing vehicles described in Section 4.3 of the Annex to Decision 2007/756/EC have expired or are expiring. The former registration entity responsible for vehicle registration should have made all required information available

under an agreement between itself and the registration entity designated according to Article 4 of Decision 2007/756/EC. This information should have been transferred by 9 November 2008. The registration entity of each Member State should have entered vehicles used in international traffic in its NVR by 9 November 2009. The registration entity of each Member State should have entered vehicles used in domestic traffic in its NVR by 9 November 2010.

- (4) The measures provided for in this Decision are in accordance with the opinion of the Committee established in accordance with Article 29(1) of Directive 2008/57/EC,

HAS ADOPTED THIS DECISION:

*Article 1*

The Annex to Decision 2007/756/EC is replaced by the Annex to this Decision.

*Article 2*

1 The European Railway Agency shall adapt the installation files and documents to be used for setting up the standard national vehicle register (sNVR), the translation engine and the virtual vehicle register to add information on authorisations for placing in service granted in other Member States (items 2, 6, 12 and 13) by 30 June 2011.

2 The European Railway Agency shall publish a guide on the application of the EU global NVR architecture by 30 June 2011.

*Article 3*

1 Member States shall adapt their national vehicle register to include information on authorisations for placing in service granted in other Member States (items 2, 6, 12 and 13 specified in the Annex) and, if they use non-standard national vehicle register, to include Field 9.2 'registered business number' specified in the Annex in accordance with the installation files referred to in Article 2 by 31 December 2011.

2 Member States shall ensure that, for the vehicles registered before the entry into force of this Decision, the registered business number of the entity in charge of maintenance is recorded in the national vehicle register by 31 December 2011.

*Article 4*

Member States shall ensure that their national vehicle register is connected to the virtual vehicle register by 31 December 2011.

*Article 5*

This Decision is addressed to the Member States.

Done at Brussels, 10 February 2011.

*For the Commission*

Siim KALLAS

*Vice-President*



---

*Status: This is the original version (as it was originally adopted).*

---

## ANNEX

### ANNEX 1.DATA

The data format of the national vehicle register (hereinafter referred to as “NVR”) is as follows.

The item numbering follows the logic of the proposed standard registration form in Appendix 4.

In addition, field(s) may be added such as comments, identification of vehicles under investigation (see Section 3.4), etc.

<b>1.</b>	<b>European Vehicle Number</b>	<b>Compulsory</b>
Content	Numeric identification code as defined in Annex P to the Technical Specification for Interoperability (TSI) on “operation and traffic management” (hereinafter referred to as “OPE TSI”) <sup>a</sup>	
Format	1.1. Number  1.2. Previous number (if applicable, for renumbered vehicle)	12 digits
<b>2.</b>	<b>Member State and NSA</b>	<b>Compulsory</b>
Content	Identification of the Member State where the vehicle has been registered and NSA that authorised its placing in service	
Format	2.1. Member State numeric code as defined in Annex P to OPE TSI	Two-digit code
<b>a</b>	Under Commission Decisions 2006/920/EC and 2008/231/EC, as amended by Decision 2009/107/EC, the same numbering system is used for both high-speed and conventional vehicles.	
<b>b</b>	For vehicle types authorised in accordance with Article 26 of Directive 2008/57/EC.	
<b>c</b>	The register provided for in Article 34 of Directive 2008/57/EC.	
<b>d</b>	Authorisation delivered in accordance with Chapter V of Directive 2008/57/EC or authorisation delivered in accordance with the authorisation regimes existing before transposition of Directive 2008/57/EC.	

	2.2. Name of NSA	Text
<b>3.</b>	<b>Manufacturing year</b>	<b>Compulsory</b>
Content	Year in which the vehicle left the factory	
Format	3. Manufacturing year	YYYY
<b>4.</b>	<b>EC reference</b>	<b>Compulsory (when available)</b>
Content	References to the “EC” declaration of verification and the issuing body (the applicant)	
Format	4.1. Date of declaration	Date
	4.2. EC reference	Text
	4.3. Name of issuing body (applicant)	Text
	4.4. Registered business number	Text
	4.5. Address of organisation, street and number	Text
	4.6. Town	Text
	4.7. Country code	ISO (see Appendix 2)
	4.8. Post code	Alphanumeric code
<b>5.</b>	<b>Reference to the European Register of Authorised Types of Vehicles (ERATV)</b>	<b>Compulsory<sup>b</sup></b>
Content	Reference allowing retrieval of the relevant	

**a** Under Commission Decisions 2006/920/EC and 2008/231/EC, as amended by Decision 2009/107/EC, the same numbering system is used for both high-speed and conventional vehicles.

**b** For vehicle types authorised in accordance with Article 26 of Directive 2008/57/EC.

**c** The register provided for in Article 34 of Directive 2008/57/EC.

**d** Authorisation delivered in accordance with Chapter V of Directive 2008/57/EC or authorisation delivered in accordance with the authorisation regimes existing before transposition of Directive 2008/57/EC.

---

**Status:** This is the original version (as it was originally adopted).

---

	technical data from ERATV <sup>c</sup> ; the reference is compulsory if the type is defined in ERATV	
Format	5. Reference allowing retrieval of the relevant technical data from ERATV	Alphanumeric code(s)
<b>5bis</b>	<b>Series</b>	<b>Optional</b>
Content	Identification of a series, if the vehicle is part of a series	
	5bis Series	Text
<b>6.</b>	<b>Restrictions</b>	<b>Compulsory</b>
Content	Any restrictions on how the vehicle may be used	
Format	6.1. Coded restrictions (see Appendix 1)	Code
	6.2. Non-coded restrictions	Text
<b>7.</b>	<b>Owner</b>	<b>Compulsory</b>
Content	Identification of the owner of the vehicle	
Format	7.1. Name of organisation	Text
	7.2. Registered business number	Text
	7.3. Address of organisation, street and number	Text
<b>a</b>	Under Commission Decisions 2006/920/EC and 2008/231/EC, as amended by Decision 2009/107/EC, the same numbering system is used for both high-speed and conventional vehicles.	
<b>b</b>	For vehicle types authorised in accordance with Article 26 of Directive 2008/57/EC.	
<b>c</b>	The register provided for in Article 34 of Directive 2008/57/EC.	
<b>d</b>	Authorisation delivered in accordance with Chapter V of Directive 2008/57/EC or authorisation delivered in accordance with the authorisation regimes existing before transposition of Directive 2008/57/EC.	

	7.4. Town	Text
	7.5. Country code	ISO (see Appendix 2)
	7.6. Post code	Alphanumeric code
<b>8.</b>	<b>Keeper</b>	<b>Compulsory</b>
Content	Identification of the keeper of the vehicle	
Format	8.1. Name of organisation	Text
	8.2. Registered business number	Text
	8.3. Address of organisation, street and number	Text
	8.4. Town	Text
	8.5. Country code	ISO (see Appendix 2)
	8.6. Post code	Alphanumeric code
	8.7. VKM (if available)	Alphanumeric code
<b>9.</b>	<b>Entity in charge of maintenance</b>	<b>Compulsory</b>
Content	Reference to the entity in charge of maintenance	
Format	9.1. Entity in charge of maintenance	Text
	9.2. Registered business number	Text

**a** Under Commission Decisions 2006/920/EC and 2008/231/EC, as amended by Decision 2009/107/EC, the same numbering system is used for both high-speed and conventional vehicles.

**b** For vehicle types authorised in accordance with Article 26 of Directive 2008/57/EC.

**c** The register provided for in Article 34 of Directive 2008/57/EC.

**d** Authorisation delivered in accordance with Chapter V of Directive 2008/57/EC or authorisation delivered in accordance with the authorisation regimes existing before transposition of Directive 2008/57/EC.

---

*Status: This is the original version (as it was originally adopted).*

---

	9.3. Address of entity, street and number	Text
	9.4. Town	Text
	9.5. Country code	ISO
	9.6. Post code	Alphanumeric code
	9.7. E-mail address	E-mail
<b>10.</b>	<b>Withdrawal</b>	<b>Compulsory when applicable</b>
Content	Date of official scrapping and/or other disposal arrangement and the code for withdrawal mode	
Format	10.1. Mode of disposal (see Appendix 3)	Two-digit code
	10.2. Withdrawal date	Date
<b>11.</b>	<b>Member States where the vehicle is authorised</b>	<b>Compulsory</b>
Content	List of Member States where the vehicle is authorised	
Format	11. Member State numeric code as defined in Annex P.4 to OPE TSI	List
<b>12.</b>	<b>Authorisation number</b>	<b>Compulsory</b>
Content	Harmonised authorisation number for placing in service, generated by NSA	
Format	12. Authorisation number	For existing vehicles: text

**a** Under Commission Decisions 2006/920/EC and 2008/231/EC, as amended by Decision 2009/107/EC, the same numbering system is used for both high-speed and conventional vehicles.

**b** For vehicle types authorised in accordance with Article 26 of Directive 2008/57/EC.

**c** The register provided for in Article 34 of Directive 2008/57/EC.

**d** Authorisation delivered in accordance with Chapter V of Directive 2008/57/EC or authorisation delivered in accordance with the authorisation regimes existing before transposition of Directive 2008/57/EC.

---



		For new vehicles: alphanumeric code based on EIN, see Appendix 2
<b>13.</b>	<b>Authorisation of placing in service</b>	<b>Compulsory</b>
Content	Date of authorisation for placing the vehicle in service <sup>d</sup> and its validity	
Format	13.1. Date of authorisation	Date (YYYYMMDD)
	13.2. Authorisation valid until (if specified)	Date (YYYYMMDD)
	13.3. Suspension of authorisation	Yes/No

**a** Under Commission Decisions 2006/920/EC and 2008/231/EC, as amended by Decision 2009/107/EC, the same numbering system is used for both high-speed and conventional vehicles.

**b** For vehicle types authorised in accordance with Article 26 of Directive 2008/57/EC.

**c** The register provided for in Article 34 of Directive 2008/57/EC.

**d** Authorisation delivered in accordance with Chapter V of Directive 2008/57/EC or authorisation delivered in accordance with the authorisation regimes existing before transposition of Directive 2008/57/EC.

## 2. ARCHITECTURE

### 2.1. Links with other registers

Several registers are being set up partly as a consequence of the new EU regulatory regime. The table below summarises which registers and databases might have links with the NVR when they are implemented.

Register or database	Entity responsible	Other entities having access
NVR (Interoperability Directive)	Registration Entity (RE) <sup>a</sup> / NSA	Other NSA/RE/RU/IM/IB/ RB/Keeper/Owner/ERA/ OTIF
ERATV (Interoperability Directive)	ERA	Public
RSRD (TAF TSI & SEDP)	Keeper	RU/IM/NSA/ERA/Keeper/ Workshops
WIMO (TAF TSI & SEDP)	Not yet decided	RU/IM/NSA/ERA/Keeper/ Workshops/User

**a** The Registration Entity (“RE”) is the entity designated by each Member State, in accordance with Article 33(1)(b) of Directive 2008/57/EC, for keeping and updating the NVR.

**b** As provided for in the Luxembourg Protocol to the Convention on International Interests in Mobile Equipment on matters specific to railway rolling stock, signed in Luxembourg on 23 February 2007.

---

*Status: This is the original version (as it was originally adopted).*

---

Railway rolling stock registry <sup>b</sup> (Cape Town Convention)	Registrar	Public
OTIF register (COTIF 99 — ATMF)	OTIF	Competent Authorities/RU/IM/IB/RB/Keeper/Owner/ERA/OTIF Sec.

**a** The Registration Entity (“RE”) is the entity designated by each Member State, in accordance with Article 33(1)(b) of Directive 2008/57/EC, for keeping and updating the NVR.

**b** As provided for in the Luxembourg Protocol to the Convention on International Interests in Mobile Equipment on matters specific to railway rolling stock, signed in Luxembourg on 23 February 2007.

---

It is not possible to wait for all registers to be ready before implementing the NVR. Therefore, the specification of the NVR must allow for later interfacing with these other registers. To this end:

- ERATV: reference is made to this in the NVR, by providing a reference to the vehicle type. The key for linking both registers is item No 5,
- RSRD: this includes some “administrative” items of the NVR. Under specification within the TAF TSI SEDP. The SEDP will take account of the NVR specification,
- WIMO: this includes data from RSRD and maintenance data. No link with the NVR is envisaged,
- VKMR: this register is managed by ERA and OTIF in cooperation (ERA for the EU and OTIF for all non-EU OTIF Member States). The keeper is recorded in the NVR. The TSI OPE specifies other global central registers (such as vehicle type codes, interoperability codes, country codes, etc.) to be managed by a “central body” resulting from cooperation between ERA and OTIF,
- railway rolling stock registry (Cape Town Convention/Luxembourg Protocol): this is a register of financial information related to mobile equipment. It has not yet been developed. There is a possible link because the UNIDROIT register needs information on the vehicle number and owner. The key for linking both registers is the first EVN assigned to the vehicle,
- OTIF registers: OTIF registers are being developed taking account of the EU vehicle registers.

The architecture of the whole system, as well as the links between the NVR and other registers, will be defined in such a way as to allow retrieval of the requested information when necessary.

## 2.2. The EU global NVR architecture

The NVR registers will be implemented by means of a decentralised solution. The objective is to implement a search engine for distributed data, using a common software application, to allow users to retrieve data from all the Local Registers (LR) in the Member States.

NVR data will be stored at national level and will be accessible using a web-based application (with its own web address).

The European Centralised Virtual Vehicle Register (EC VVR) will be composed of two sub-systems:

- the Virtual Vehicle Register (VVR), which is the central search engine in ERA,
- the National Vehicle Register(s) (NVR), which are the LR in the Member States. The Member States can use the standard NVR (sNVR) developed by the Agency or develop their own applications in conformity with this specification. In the latter

case, for communication by the NVR with the VVR the Member States will use a Translation Engine (TE) developed by the Agency.

Figure 1

### EC-VVR architecture

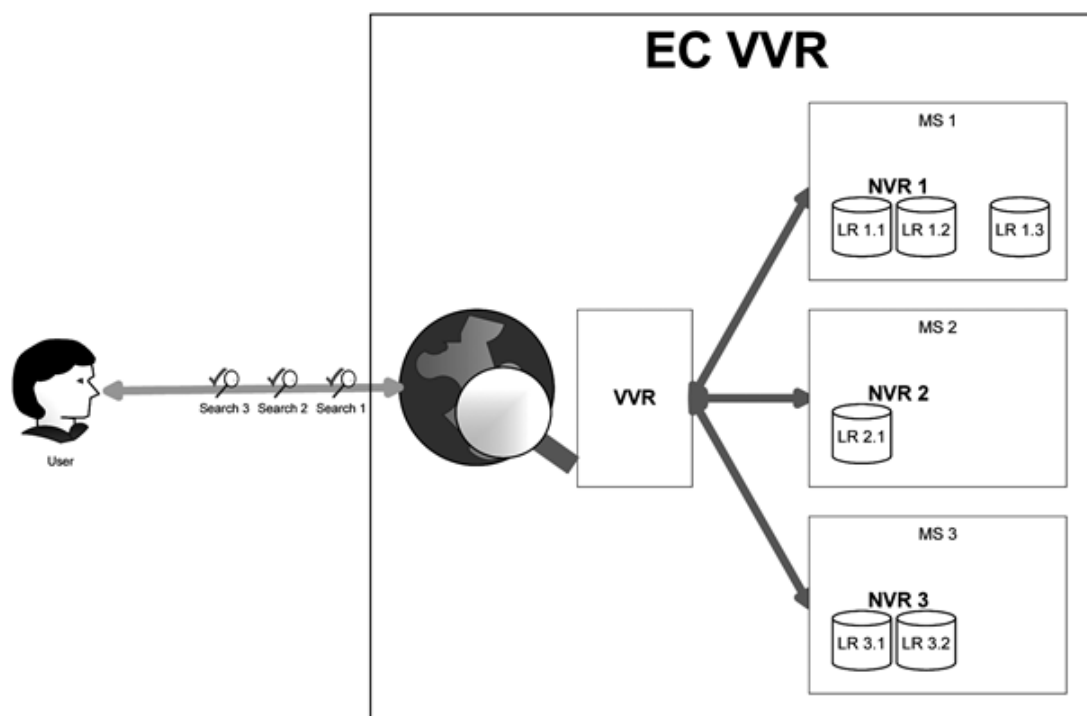

This architecture is based on two complementary sub-systems to enable searches on data stored locally in all Member States. It will:

- establish computerised registers at national level and open them to cross-consultation,
- replace paper registers by computerised records, to allow the Member States to manage and share information with other Member States,
- allow connections between the NVRs and the VVR, using common standards and terminology.

The main principles of this architecture are as follows:

- all NVRs will be part of the computer based network system,
- all Member States will view the common data when accessing the system,
- double registration of data and possible related errors will be avoided once the VVR has been established,
- up-to-date data.

The Agency will make available to the REs the following installation files and documents to be used for setting up the sNVR and TE and for connecting them to the central VVR:

- installation files:
  - sNVR\_Installation\_Files,
  - TE\_Installation\_Files,
- documents:
  - Administrator\_Guide\_sNVR,
  - CSV\_export,

- CSV\_import,
- sNVR\_Deployment\_Guide,
- User\_Guide\_sNVR,
- NVR-TE\_Deployment\_Guide,
- NVR-TE\_Integration\_Guide,
- User\_Guide\_VVR.

### 3. OPERATING MODE

#### 3.1. Use of the NVR

The NVR is to be used for the following purposes:

- recording authorisation,
- recording the EVN allocated to vehicles,
- looking for brief, European-wide information on a particular vehicle,
- following up legal aspects such as obligations and legal information,
- retrieving information for inspections mainly related to safety and maintenance,
- enabling contact with the owner and keeper,
- cross-checking some safety requirements before issuing Safety Certificates,
- following up a particular vehicle.

#### 3.2. Application forms

##### 3.2.1. *Application for registration*

The form to be used is in Appendix 4.

The entity applying for vehicle registration ticks the “New registration” box. It then fills in the first part of the form with all the necessary information from item 2 to item 9 and item 11 and then forwards it to the:

- RE of the Member State where registration is sought,
- RE of the first Member State where it intends to operate, for a vehicle coming from a third country.

##### 3.2.2. *Registering a vehicle and issuing a European Vehicle Number.*

In the case of first registration, the RE concerned issues the European Vehicle number.

It is possible to have a separate registration form per vehicle or a single form for a whole set of vehicles of the same series or order with a list of the vehicle numbers attached.

The RE must take reasonable steps to ensure the accuracy of the data it enters in the NVR. To this end the RE can request information from other REs, in particular when the entity applying for registration in a Member State is not established in that Member State.

##### 3.2.3. *Changing one or more registration item(s)*

The entity applying for a change to its vehicle registration item(s):

- ticks the “Modification” box,
- fills in the current EVN (item No 0),
- ticks the box(es) before the modified item(s),
- enters the new content of the modified item(s), and then forwards the form to the REs of all the Member States where the vehicle is registered.

The use of the standard form might not be sufficient for certain cases. If necessary, the RE concerned may therefore submit additional documents in either paper or electronic form.

Unless otherwise specified in the registration documents, the keeper of the vehicle is considered to be the “registration holder” in the meaning of Article 33(3) of Directive 2008/57/EC.

Should a keeper change, it is the responsibility of the currently registered keeper to notify the RE and the RE has to notify the new keeper of the change of registration. The former keeper is removed from the NVR and relieved of its responsibilities only when the new keeper has acknowledged its acceptance of keeper status. If on the date of de-registration of the currently registered keeper no new keeper has accepted the keeper status, the registration of the vehicle is suspended.

In cases where, in accordance with the OPE TSI, due to technical changes, the vehicle has to be given a new EVN, the registration holder shall inform of these changes and, if applicable, of the new authorisation for placing in service the RE of the Member State where the vehicle is registered. This RE shall assign to the vehicle a new EVN.

#### 3.2.4. *Withdrawal of registration*

The entity applying for withdrawal of registration ticks the “Withdrawal” box. It then fills in item No 10 and forwards the form to the REs of all the Member States where the vehicle is registered.

The RE delivers the withdrawal registration by filling in the date of withdrawal and acknowledging the withdrawal to the entity.

#### 3.2.5. *Authorisation in several Member States*

1. When a vehicle equipped with a driving cab already authorised and registered in one Member State is authorised in another Member State, it must be registered in the NVR of the latter Member State. In this case, however, only data relating to items 1, 2, 6, 11, 12 and 13 and, where relevant, data relating to the fields added to the NVR by the latter Member State are to be recorded, as only these data relate to the latter Member State.

This provision is applicable as long as the VVR and the links with all relevant NVRs are not fully operational and, during this period, the REs concerned will exchange information in order to ensure that data relating to the same vehicle are consistent.

2. Vehicles not equipped with a driving cab, such as freight wagons, passenger cars and some special vehicles, are registered only in the NVR of the Member State where they are first placed in service.
3. For any vehicle, the NVR where it is firstly registered contains the data relating to items 2, 6, 12 and 13 for each of the Member States where an authorisation for placing in service has been granted to this vehicle.

### 3.3. **Access rights**

The access rights to data of an NVR from a given Member State “XX” are listed in the table below, in which the access codes are defined as follows:

Access code	Type of access
0.	No access
1.	Restricted consultation (conditions in “Read rights” column)

---

*Status: This is the original version (as it was originally adopted).*

---

2.	Unrestricted consultation
3.	Restricted consultation and updating
4.	Unrestricted consultation and updating

<b>Entity</b>	<b>Definition</b>	<b>Read rights</b>	<b>Update rights</b>	<b>Item No 7</b>	<b>All other items</b>
RE/ NSA “XX”	RE/NSA in Member State “XX”	All data	All data	4	4
Other NSA/ REs	Other NSAs and/or other REs	All data	None	2	2
ERA	European Railway Agency	All data	None	2	2
Keepers	Vehicle Keeper	All data on vehicles of which it is keeper	None	1	1
Fleet managers	Manager of vehicles as appointed by the keeper	Vehicles for which they have been appointed manager by the keeper	None	1	1
Owners	Owner of the vehicle	All data on vehicles of which they are the owners	None	1	1
RUs	Train Operator	All data based on vehicle number	None	0	1
IMs	Infrastructure Manager	All data based on vehicle number	None	0	1
IBs and RBs	Checking and auditing bodies notified by Member States	All data on vehicles being checked or audited	None	2	2

Other legitimate users	All casual users recognised by NSA or ERA	To be defined as appropriate, duration possibly limited	None	0	1
------------------------	---	---	------	---	---

### 3.4. Historical records

All data in the NVR must be retained for 10 years from the date of withdrawal of a vehicle registration. As a minimum, data must be available online for the first 3 years. After 3 years, data may be kept either electronically, in paper form or in any other archiving system. If at any time during the 10-year period an investigation involving a vehicle or vehicles is started, data relating to these vehicles must be retained beyond the 10-year period if so required.

After withdrawal of a vehicle registration, any of the registration numbers assigned to the vehicle must not be assigned to any other vehicle for 100 years from the date the vehicle is withdrawn.

Any changes in the NVR should be recorded. The management of historical changes could be addressed by IT solutions.

## 4. EXISTING VEHICLES

### 4.1. Data content

The 13 data items retained are listed below, with an indication as to which are compulsory and which are not.

#### 4.1.1. Item No 1 — European Vehicle Number (Compulsory)

##### (a) Vehicles already possessing a 12-digit number

Countries where there is a unique country code:

These vehicles should keep their current number. The 12-digit number should be registered as such without any modification.

Countries where there is both a main country code and a previously allocated specific code:

- Germany, with the main country code 80 and the specific code 68 for AAE (Ahaus Alstätter Eisenbahn),
- Switzerland, with the main country code 85 and the specific code 63 for BLS (Bern–Lötschberg–Simplon Eisenbahn),
- Italy, with the main country code 83 and the specific code 64 for FNME (Ferrovie Nord Milano Esercizio),
- Hungary, with the main country code 55 and the specific code 43 for GySEV/ROeEE (Győr-Sopron-Ebenfurti Vasút Részvénytársaság/Raab-Ödenburg-Ebenfurter Eisenbahn).

These vehicles should keep their current number. The 12-digit number should be registered as such without any modification<sup>(3)</sup>.

The IT system has to consider both codes (main country code and specific code) as relating to the same country.

##### (b) Vehicles without a 12-digit number

A two-step procedure applies.

- A 12-digit number (according to OPE TSI) defined in accordance with the vehicle's characteristics is allocated in the NVR. The IT system should link this registered number to the current vehicle number.
- For vehicles used in international traffic, except those reserved for historical use: the 12-digit number is physically applied to the vehicle itself within a period of 6 years after allocation in the NVR. For vehicles used in domestic traffic and for those reserved for historical use: the physical application of the 12-digit number is voluntary.

#### 4.1.2. *Item No 2 — Member State and NSA (Compulsory)*

The item "Member State" must always refer to the Member State where the vehicle is registered in its NVR. For vehicles from third countries, this item refers to the first Member State that authorised the vehicle to be placed in service on the European Union rail network. The item "NSA" refers to the entity that delivered the authorisation for placing the vehicle in service.

#### 4.1.3. *Item No 3 — Manufacturing Year*

Where the manufacturing year is not known precisely, the approximate year should be entered.

#### 4.1.4. *Item No 4 — EC Reference*

Normally such a reference does not exist for existing vehicles except for a handful of HS RS. To be recorded only if available.

#### 4.1.5. *Item No 5 — Reference to the ERATV*

To be recorded only if available.

Until ERATV is set up, reference may be made to the Rolling Stock Register (Article 22a of Council Directive 96/48/EC<sup>(4)</sup> and Article 24 of Directive 2001/16/EC of the European Parliament and of the Council<sup>(5)</sup>).

#### 4.1.6. *Item No 6 — Restrictions*

To be recorded only if available.

#### 4.1.7. *Item No 7 — Owner (Compulsory)*

Compulsory and normally available.

#### 4.1.8. *Item No 8 — Keeper (Compulsory)*

Compulsory and normally available. The VKM (unique code as indicated in the VKM register) must be entered if the keeper has it.

#### 4.1.9. *Item No 9 — Entity in charge of maintenance (Compulsory)*

This item is compulsory.

#### 4.1.10. *Item No 10 — Withdrawal*

Applicable as appropriate.

#### 4.1.11. *Item No 11 — Member States where the vehicle is authorised*

Normally, RIV wagons, RIC coaches and vehicles under bilateral or multilateral agreements are registered as such. If this information is available it should be recorded accordingly.

#### 4.1.12. *Item No 12 — Authorisation number*



To be recorded only if available

#### 4.1.13. *Item No 13 — Placing in service (Compulsory)*

Where the date of placing into service is not known precisely, the approximate year should be entered.

#### 4.2. **Procedure**

The entity previously responsible for vehicle registration is to make all information available to the NSA or RE of the country where it is located.

Existing freight wagons and passenger cars are to be registered only in the NVR of the Member State where the former registration entity was located.

If an existing vehicle had been authorised in several Member States, the RE that registers this vehicle sends the relevant data to the REs of the other Member States concerned.

The NSA or RE includes the information in its NVR.

The NSA or RE informs all the parties involved when the information transfer is completed. At least the following entities are to be informed:

- the entity previously responsible for vehicle registration,
- the keeper,
- ERA.

## Appendix 1

### **RESTRICTION CODING**

#### 1. **PRINCIPLES**

Restrictions (technical characteristics) already recorded in other registers to which NSAs have access do not need to be repeated in the NVR.

Acceptance in cross-border traffic is based on:

- the information coded in the vehicle number,
- the alphabetical coding, and
- the vehicle marking.

Therefore, such information does not need to be repeated in the NVR.

#### 2. **STRUCTURE**

The codes are structured in three levels:

- 1st level: Category of restriction,
- 2nd level: Type of restriction,
- 3rd level: Value or specification.

---

*Status: This is the original version (as it was originally adopted).*

---

## RESTRICTION CODING

Cat	Type	Value	Name
<b>1</b>			<b>Technical restriction related to construction</b>
	1	Numeric (3)	Minimum curve radius in metres
	2	—	Track circuit restrictions
	3	Numeric (3)	Speed restrictions in km/h (marked on wagons and coaches but not marked on locomotives)
<b>2</b>			<b>Geographical restriction</b>
	1	Alphanumeric (3)	Kinematic gauge (coding WAG TSI Annex C)
	2	Coded list	Wheel set gauge
		1	Variable gauge 1435/1520
		2	Variable gauge 1435/1668
	3	—	No CCS on board
	4	—	ERTMS A on board
	5	Numeric (3)	B system on board <sup>a</sup>
<b>3</b>			<b>Environmental restrictions</b>
	1	Coded list	Climatic zone EN50125/1999
		1	T1
		2	T2
		3	T3
<b>4</b>			<b>Restrictions on use included in the authorisation certificate</b>

- a** If the vehicle is equipped with more than one B system, an individual code for each system must be indicated. The numeric code is composed of three characters where:
- 1xx is used for a vehicle equipped with a signalling system,
  - 2xx is used for a vehicle equipped with radio.
- Xx corresponds to the numerical coding in Annex B to the CCS TSI.

---

**Status:** This is the original version (as it was originally adopted).

---

	1	—	Time-based
	2	—	Condition-based (distance travelled, wear, etc.)

- a** If the vehicle is equipped with more than one B system, an individual code for each system must be indicated. The numeric code is composed of three characters where:
- 1xx is used for a vehicle equipped with a signalling system,
  - 2xx is used for a vehicle equipped with radio.
- Xx corresponds to the numerical coding in Annex B to the CCS TSI.

## Appendix 2

### STRUCTURE AND CONTENT OF THE EIN

#### Code for the harmonised numbering system, called European Identification Number (EIN), for Safety Certificates and other documents

Example:

I	T	5	1	2	0	0	6	0	0	0	5
Country code (two letters)		Type of document (two digits)		Issue year (four digits)				Counter (four digits)			
Field 1		Field 2		Field 3				Field 4			

#### FIELD COUNTRY CODE (TWO LETTERS)

1 —

The codes are those officially published and updated on the website of the Publications Office of the European Union in the *Interinstitutional style guide* (<http://publications.eu.int/code/en/en-5000600.htm>)

State	Code
Austria	AT
Belgium	BE
Bulgaria	BG
Cyprus	CY
Czech Republic	CZ
Denmark	DK
Estonia	EE
Finland	FI
France	FR
Germany	DE
Greece	EL

---

*Status: This is the original version (as it was originally adopted).*

---

Hungary	HU
Iceland	IS
Ireland	IE
Italy	IT
Latvia	LV
Liechtenstein	LI
Lithuania	LT
Luxembourg	LU
Norway	NO
Malta	MT
Netherlands	NL
Poland	PL
Portugal	PT
Romania	RO
Slovakia	SK
Slovenia	SI
Spain	ES
Sweden	SE
Switzerland	CH
United Kingdom	UK

The code for multinational safety authorities should be composed in the same way. Currently there is only one authority: the Channel Tunnel Safety Authority. The following code is to be used:

<b>Multinational safety authority</b>	<b>Code</b>
Channel Tunnel Intergovernmental Commission	CT

#### FIELD TYPE OF DOCUMENT (TWO-DIGIT NUMBER)

2 —

Two digits allow the type of document to be identified:

- the first digit identifies the general classification of the document,
- the second digit specifies the document subtype.

This numbering system can be extended when other codes are needed. The following list is a proposed list of known, possible combinations of two-digit numbers plus combinations for authorisation of the placing in service of vehicles:

<b>Number combination for Field 2</b>	<b>Document type</b>	<b>Document subtype</b>
[0 1]	Licences	Licences for RUs
[0 x]	Licences	Others
[1 1]	Safety Certificate	Part A
[1 2]	Safety Certificate	Part B
[1 x]	Reserved	Reserved
[2 1]	Safety Authorisation	
[2 2]	Reserved	Reserved
[2 x]	Reserved	Reserved
[3 x]	Reserved, e.g. maintenance for rolling stock, for infrastructure or other	
[4 x]	Reserved for Notified Bodies	E.g. different kinds of Notified Bodies
[5 1] and [5 5] <sup>a</sup>	Authorisation for placing in service	Tractive vehicles
[5 2] and [5 6] <sup>a</sup>	Authorisation for placing in service	Hauled passenger vehicles
[5 3] and [5 7] <sup>a</sup>	Authorisation for placing in service	Wagons
[5 4] and [5 8] <sup>a</sup>	Authorisation for placing in service	Special vehicles
[5 9] <sup>b</sup>	Authorisation of type of vehicle	
[6 0]	Authorisation for placing in service	Infrastructure, Energy and Control Command Signalling track-side assembly Subsystems
[6 1]	Authorisation for placing in service	Infrastructure Subsystem
[6 2]	Authorisation for placing in service	Energy Subsystem

**a** If the four digits reserved for Field 4 “Counter” are fully used within a year, the first two digits of Field 2 will change respectively from:

- [5 1] to [5 5] for tractive vehicles,
- [5 2] to [5 6] for hauled passenger vehicles,
- [5 3] to [5 7] for wagons,
- [5 4] to [5 8] for special vehicles.

**b** The digits allocated in Field 4 are:

- from 1 000 to 1 999 for traction vehicles,
- from 2 000 to 2 999 for hauled passenger vehicles,
- from 3 000 to 3 999 for wagons,
- from 4 000 to 4 999 for special vehicles.

---

*Status: This is the original version (as it was originally adopted).*

---

[6 3]	Authorisation for placing in service	Control Command Signalling track-side assembly Subsystem
[7 1]	Train driving licence	Counter up to and including 9 999
[7 2]	Train driving licence	Counter between 10 000 up to and including 19 000
[7 3]	Train driving licence	Counter between 20 000 up to and including 29 000
[8 x] ... [9 x]	Reserved (two document types)	Reserved (10 subtypes each)
<p><b>a</b> If the four digits reserved for Field 4 “Counter” are fully used within a year, the first two digits of Field 2 will change respectively from:</p> <ul style="list-style-type: none"> <li>— [5 1] to [5 5] for tractive vehicles,</li> <li>— [5 2] to [5 6] for hauled passenger vehicles,</li> <li>— [5 3] to [5 7] for wagons,</li> <li>— [5 4] to [5 8] for special vehicles.</li> </ul>		
<p><b>b</b> The digits allocated in Field 4 are:</p> <ul style="list-style-type: none"> <li>— from 1 000 to 1 999 for traction vehicles,</li> <li>— from 2 000 to 2 999 for hauled passenger vehicles,</li> <li>— from 3 000 to 3 999 for wagons,</li> <li>— from 4 000 to 4 999 for special vehicles.</li> </ul>		

#### FIELD ISSUE YEAR (FOUR-DIGIT NUMBER)

3 —

This Field indicates the year (in the specified format yyyy, i.e. four digits) in which the authorisation was issued.

#### FIELD COUNTER

4 —

The counter is a progressive number incremented by one unit each time a document is issued, regardless if it is a new, renewed or updated/amended authorisation. Even where a certificate is revoked or an authorisation is suspended, its number cannot be used again.

Every year the counter restarts from zero.

### Appendix 3

#### WITHDRAWAL CODING

Code	Withdrawal mode	Description
00	None	The vehicle has a valid registration.
10	Registration suspended No reason specified	The vehicle’s registration is suspended at the request of the owner or keeper or by a decision of the NSA or RE.

11	Registration suspended	The vehicle is destined for storage in working order as an inactive or strategic reserve.
20	Registration transferred	The vehicle is known to be reregistered under a different number or by a different NVR, for continued use on (all or part of) the European railway network.
30	Withdrawal No reason specified	The vehicle's registration for operating on the European railway network has ended without known reregistration.
31	Withdrawal	The vehicle is destined for continued use as a rail vehicle outside the European railway network.
32	Withdrawal	The vehicle is destined for the recovery of major interoperable constituents/modules/spares or major rebuilding.
33	Withdrawal	The vehicle is destined for scrapping and disposal of materials (including major spares) for recycling.
34	Withdrawal	The vehicle is destined to be "historic preserved rolling stock" for operation on a segregated network, or for static display, outside the European railway network.

**Use of codes**

- If the reason for withdrawal is not specified, codes 10, 20 and 30 are to be used to indicate the change of registration status.
- If the reason for withdrawal is available, codes 11, 31, 32, 33 and 34 are options available within the NVR database. These codes are based solely on information provided by the keeper or owner to the RE.

**Registration issues**

- A vehicle that has its registration suspended or withdrawn may not operate on the European railway network under the recorded registration.
- A reactivation of a registration after suspension will require the verification by the registration entity of the conditions which caused the suspension.
- A transfer of registration under the conditions set out in Article 1b of Commission Decision 2006/920/EC<sup>(6)</sup> and Article 1b of Commission Decision 2008/231/EC<sup>(7)</sup>, as

---

*Status: This is the original version (as it was originally adopted).*

---

amended by Decision 2010/640/EU<sup>(8)</sup>, consists of a new registration of the vehicle and subsequent withdrawal of the old registration.



## Appendix 4

### STANDARD FORM FOR REGISTRATION



#### Standard form for registration of authorised vehicles <sup>(1)</sup>

in conformity with Directive 2008/57/EC and applicable national legislation

Application for:                      New registration                       Modification  <sup>(2)</sup>                      Withdrawal

#### INFORMATION ABOUT THE VEHICLE

1. **Number**

1.1. European Vehicle Number <sup>(3)</sup> \_ \_ \_ \_ \_ - - - - -

1.2. Number previously assigned to the vehicle <sup>(4)</sup>

2. **Member State where registration is sought and NSA that authorised the vehicle**

2.1. Member State: \_ \_

2.2. Name of NSA: .....

3. **Manufacturing year:** \_ \_ \_ \_

4. **EC reference**

4.1. Date of declaration: \_ \_ \_ \_ \_

4.2. EC reference: .....

4.3. Name of issuing body: .....

4.4. Registered business number: .....

Address of organisation

4.5. Street and number: .....

4.6. Town: .....

4.7. Country code: ..... 4.8. Post code:.....

5. **Reference to the European register of authorised types of vehicles:**

5bis. **Series**

<sup>(1)</sup> This form may also be produced electronically.

<sup>(2)</sup> The box before each modified item also has to be ticked.

<sup>(3)</sup> Not applicable for first registration.

<sup>(4)</sup> Not applicable for first registration.



**Identification of the entity applying for registration:** .....

Date: \_ \_ \_ \_ \_

Name and signature of responsible officer: .....

---

**SAFETY AUTHORITY REFERENCES**

1.1. **Allocated European Vehicle Number** <sup>(1)</sup> \_ \_ \_ \_ \_

12. **Authorisation number** \_ \_ \_ \_ \_

13. **Placing in service**

13.1. Date of authorisation: \_ \_ \_ \_ \_

13.2. Authorisation valid until: \_ \_ \_ \_ \_

Date application received: \_ \_ \_ \_ \_

Date of withdrawal: \_ \_ \_ \_ \_

---

<sup>(1)</sup> It is possible to attach a list for several vehicles of the same series or order.

---

*Status: This is the original version (as it was originally adopted).*

---

Appendix	GLOSSARY	Abbreviation	Definition	CCS	Control	Command
5	System	CIS	Commonwealth of Independent States	COTIF	Convention concerning International Carriage by Rail	CR
	(System)	DB	Database	EC	European Commission	EC VVR
			European Centralised Virtual Vehicle Register	EIN	European Identification Number	EN
			European Standard (Euro Norm)	EVN	European Vehicle Number	ERA
			European Railway Agency, also referred to as “the Agency”	ERATV	European Register of Authorised Types of Vehicles	ERTMS
			European Rail Traffic Management System	EU	European Union	HS
			High Speed (System)	IB	Investigating Body	ISO
			International Organisation for Standardisation	IM	Infrastructure Manager	INF
			Infrastructure	IT	Information Technology	LR
			Local Register	NoBo	Notified Body	NSA
			National Safety Authority	NVR	National Vehicle Register	OPE (TSI)
			Operation and Traffic management (TSI)	OTIF	Intergovernmental Organisation for International Carriage by Rail	RE
			Registration Entity, i.e. the body responsible for keeping and updating the NVR	RRB	Regulatory Body	RIC
			Regulations governing the reciprocal use of carriages and brake vans in international traffic	RIV	Regulations concerning the reciprocal use of wagons in international traffic	RS or RST
			Rolling Stock	RSRD (TAF)	Rolling Stock Reference Database (TAF)	RUR
			Railway Undertaking	SEDP (TAF)	Strategic European Deployment Plan (TAF)	TAF (TSI)
			Telematic Applications for Freight (TSI)	TSI	Technical Specification for Interoperability	VKM
			Vehicle Keeper Marking	VKMR	Vehicle Keeper Marking Register	VVR
			Virtual Vehicle Register	WAG (TSI)	Wagon (TSI)	WIMO (TAF)
			Wagon and Intermodal Operational Database (TAF)			

- (1) OJ L 191, 18.7.2008, p. 1.
- (2) OJ L 305, 23.11.2007, p. 30.
- (3) However, any new vehicles placed in service for AAE, BLS, FNME and GySEV/ROeEE are to be given the standard country code.
- (4) OJ L 235, 17.9.1996, p. 6.
- (5) OJ L 110, 20.4.2001, p. 1.
- (6) OJ L 359, 18.12.2006, p. 1.
- (7) OJ L 84, 26.3.2008, p. 1.
- (8) OJ L 280, 26.10.2010, p. 29.