

Commission Decision of 19 November 2008 establishing detailed guidelines for the implementation and application of Annex II to Directive 2004/8/EC of the European Parliament and of the Council (notified under document number C(2008) 7294) (Text with EEA relevance) (2008/952/EC)

COMMISSION DECISION

of 19 November 2008

establishing detailed guidelines for the implementation and application of Annex II to Directive 2004/8/EC of the European Parliament and of the Council

(notified under document number C(2008) 7294)

(Text with EEA relevance)

(2008/952/EC)

THE COMMISSION OF THE EUROPEAN COMMUNITIES,

Having regard to the Treaty establishing the European Community,

Having regard to Directive 2004/8/EC of the European Parliament and of the Council of 11 February 2004 on the promotion of cogeneration based on a useful heat demand in the internal energy market and amending Directive 92/42/EEC⁽¹⁾, and in particular Annex II, point (e) thereof,

Whereas:

- (1) Directive 2004/8/EEC provides that Member States must establish a system of guarantees of origin for electricity produced from high-efficiency cogeneration.
- (2) This electricity should be generated in a process linked to the production of useful heat and calculated in accordance with the methodology laid down in Annex II to Directive 2004/8/EC.
- (3) With an aim of ensuring a harmonised methodology for calculating the amount of electricity from cogeneration, it is necessary to adopt Guidelines clarifying the procedures and definitions laid down in Annex II to Directive 2004/8/EC.
- (4) Moreover, those Guidelines should allow Member States to fully transpose crucial parts of Directive 2004/8/EC such as guarantees of origin and establishment of support schemes for high efficiency cogeneration. They should provide further legal certainty for the energy market in the Community and thus contribute to remove barriers for new investments. They should also help to provide clear criteria when screening applications for State aid and financial support for cogeneration from Community funds.
- (5) The measures provided for in this Decision are in accordance with opinion of the Committee established by Article 14(1) of Directive 2004/8/EC,

HAS ADOPTED THIS DECISION:

Article 1

The detailed guidelines clarifying the procedures and definitions necessary for the application of the methodology to determine the quantity of electricity from cogeneration, laid down in Annex II to Directive 2004/8/EC, are set out in the Annex to this Decision.

The guidelines shall establish a harmonised methodology for calculating this amount of electricity.

Article 2

This Decision is addressed to the Member States.

Done at Brussels, 19 November 2008.

For the Commission

Mariann FISCHER BOEL

Member of the Commission

ANNEX

Detailed guidelines for the implementation and application of Annex II to Directive 2004/8/EC

I. Calculation of the electricity from cogeneration

1. A cogeneration unit operating with maximum technically possible heat recovery from the cogeneration unit itself is said to be operating in *full cogeneration mode*. The heat has to be produced at the site pressure and temperature levels required for the specific useful heat demand or market. In the case of full cogeneration mode, all electricity is considered combined heat and power (CHP) electricity (see Figure 1).
2. For cases in which the plant does not operate in full cogeneration mode under normal conditions of use, it is necessary to identify the electricity and heat not produced under cogeneration mode, and to distinguish it from the CHP production. This is to be done based on the principles defining the CHP boundaries described in Section II. The energy input and output of the heat-only-boilers (top-up, back-up boilers) which in many cases are part of the on-site technical installations are to be excluded, as illustrated in Figure 1. The arrows inside the 'Cogeneration Unit' box illustrate the energy flow over system boundaries.

Figure 1

CHP part, non-CHP part and heat-only boilers within a plant

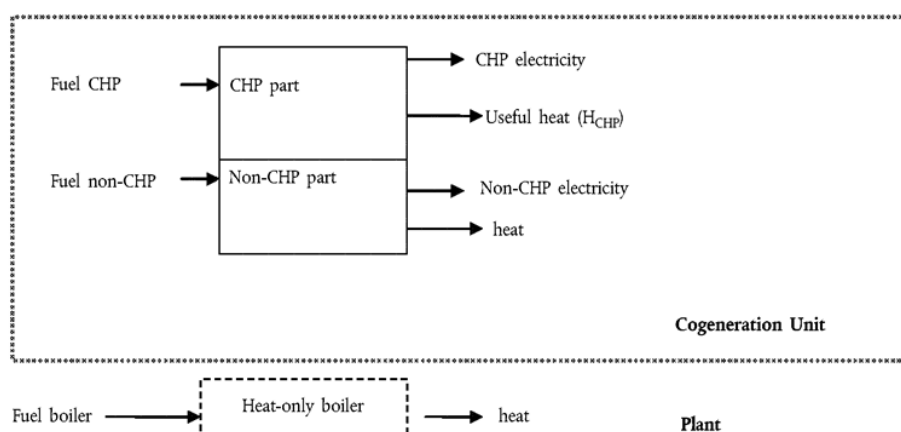

3. For micro-cogeneration units, the certified values have to be issued, approved or supervised by the national authority or competent body appointed by each Member State as referred to in Article 5(2) of Directive 2004/8/EC.
4. The electricity from cogeneration is calculated in accordance with the following steps.
5. Step 1
 - 5.1. To distinguish which part of the electricity produced is not recognised as electricity from cogeneration, it is first necessary to calculate the overall efficiency of the cogeneration unit.
 - 5.2. The overall efficiency of a cogeneration unit is determined in the following way: the energy output of the CHP plant (electricity, mechanical⁽²⁾ energy and useful heat) over a defined reporting period shall be divided by the fuel input to the cogeneration unit over the same reporting period, i.e.

Overall efficiency = (energy output)/(fuel input)

- 5.3. The calculation of overall efficiency has to be based on the actual operational data taken from real/registered measured values of the specific cogeneration unit, collected over the reporting period. Generic or certified values provided by the manufacturer (according to the specific technology) cannot be used⁽³⁾.
- 5.4. The *reporting period* means the period of operation of the cogeneration unit for which the electricity output has to be established. Normally, reporting will be done on an annual basis. However, shorter periods are permissible. The maximum period is one year and the minimum period is one hour. Reporting periods may differ from the frequency of measurements.
- 5.5. The *energy output* means the total electrical energy (CHP and non-CHP) and useful heat (H_{CHP}) generated in the CHP plant over a reporting period.
- 5.6. In accordance with the definitions in Article 3(b) and 3(c) of Directive 2004/8/EC, the following heat can be regarded as useful heat (H_{CHP}): heat that is used for process heating or space heating and/or delivered for subsequent cooling purposes; heat delivered to district heating/cooling networks; exhaust gases from a cogeneration process that are used for direct heating and drying purposes.
- 5.7. Examples of heat other than useful heat are the following: heat rejected to the environment without any beneficial use⁽⁴⁾; heat lost from chimneys or exhausts; heat rejected in equipment such as condensers or heat-dump radiators; heat used internally for de-aeration, condensate heating, make-up water and boiler feed-water heating used in the operation of boilers within the boundaries of the cogeneration unit, such as heat recovery boilers. The heat content of the returned condensate to the cogeneration plant (e.g. after being used for district heating or in an industrial process) is not considered as useful heat and may be subtracted from the heat flow associated with the steam production in line with the Member States practices.
- 5.8. Exported heat used in power generation on another site does not qualify as useful heat but is considered as a part of the internal heat transfer within a cogeneration unit. In this case, the electricity generated from this exported heat is included in the total electricity output (see Figure 4).
- 5.9. *Non-CHP electricity* means the electrical energy generated by a cogeneration unit in a reporting period at times when one of the following situations occurs: no related heat produced by the cogeneration process or part of the heat produced cannot be considered as useful heat.
- 5.10. Non-CHP electricity generation might occur in the following cases:
- (a) in processes with insufficient useful heat demand or no generation of useful heat energy (for example, gas turbines, internal combustion engines and fuel cells with insufficient or no utilisation of heat);
 - (b) in processes with heat rejection facilities (for example, in the condensing part of steam cycle power plants and in combined-cycle power plants with extraction-condensing steam turbines).
- 5.11. The *fuel input* means the total (CHP and non-CHP) fuel energy based on the lower heating value needed to generate (CHP and non-CHP) electrical energy and heat produced in the cogeneration process during the reporting period. Examples of fuel inputs are any combustibles, steam and other heat imports, and process waste heat

used in the cogeneration unit for electricity generation⁽⁵⁾. Returned condensate from the cogeneration process (in the case of steam output) is not considered to be fuel input.

5.12. CHP fuel energy means the fuel energy based on lower heating value needed in a cogeneration process to co-generate CHP electrical energy and useful heat energy in a reporting period (see Figure 1).

5.13. Non-CHP fuel energy means the fuel energy, based on lower heating value, needed in a CHP unit for heat production not considered to be useful heat and/or non-CHP electrical energy in a reporting period (see Figure 1).

6. Step 2

6.1. All the measured electrical energy output and all the measured useful heat output can be taken into account when applying the methodology for determining the efficiency of the cogeneration process if the overall efficiency of the cogeneration unit is equal or higher than

(a) 80 % for ‘Combined cycle gas turbines with heat recovery’ and ‘Steam condensing extraction turbines-based plants’, and

(b) 75 % for the other types of cogeneration units,

as indicated in Annex II of the Directive,

6.2. For micro-cogeneration units (up to 50 kW_e) with actual operation under cogeneration mode, it is allowed to compare the calculated overall efficiency (according to Step 1) with the certified values provided by the manufacturer as long as the primary energy savings (PES), as defined in Annex III point (b) to Directive 2004/8/EC, are higher than zero.

7. Step 3

7.1. If the overall efficiency of the cogeneration unit is lower than the threshold values (75 %-80 %), non-CHP electricity generation may take place and the unit can be split into two virtual parts, the CHP part and the non-CHP part.

7.2. For the CHP part, the plant operator shall check the load pattern (useful heat demand) and evaluate whether the unit operates in full cogeneration mode during certain periods. If this is the case, the plant operator shall measure actual heat and electrical energy output from the cogeneration unit for this situation and during these periods. These data will allow him to determine the actual ‘power to heat ratio’ (C_{actual})⁽⁶⁾.

7.3. This actual ‘power to heat ratio’ will allow the operator to calculate which part of the electricity measured during the reporting period is recognised as CHP electricity according to the formula $E_{\text{CHP}} = H_{\text{CHP}} \times C_{\text{actual}}$.

7.4. For cogeneration units under development or in the first year of operation, where measured data cannot be established, the design ‘power to heat ratio’ (C_{design}) in full cogeneration mode can be used. The CHP electricity is calculated according to the formula $E_{\text{CHP}} = H_{\text{CHP}} \times C_{\text{design}}$.

8. Step 4

8.1. If the actual ‘power to heat ratio’ of the cogeneration unit is not known, the plant operator can use the default ‘power to heat ratio’ (C_{default}), as specified in Annex II to

Directive 2004/8/EC, to calculate CHP electricity. The CHP electricity is calculated according to the formula $E_{\text{CHP}} = H_{\text{CHP}} \times C_{\text{default}}$.

- 8.2. In that case however, the operator has to notify to the national authority or to the competent body appointed by each Member State as referred to in Article 5 of the Directive the reasons for not having a known actual 'power to heat ratio', the period for which data are lacking and the measures taken to remedy the situation.
9. Step 5
- 9.1. The calculated electricity in Step 3 and Step 4 will then be taken into account when applying the methodology for determining the efficiency of the cogeneration process including the calculation of the primary energy savings (PES) of the cogeneration process.
- 9.2. To calculate the primary energy savings, it is necessary to determine the non-CHP fuel consumption. The non-CHP fuel consumption is calculated as the amount of 'non-CHP electricity production' divided by 'the plant specific efficiency value for electricity production'.
- II. Cogeneration system boundaries
1. The boundaries of a cogeneration system shall be laid around the cogeneration process itself. Meters for defining input and output shall be available for monitoring and should be placed on these boundaries.
2. A cogeneration unit supplies energy products to a consumer area. The consumer area does not belong to the cogeneration unit, but consumes the energy outputs generated by the cogeneration unit. The two areas are not necessarily distinct geographical areas within the site but, rather, areas that may be represented as shown below. The consumer area can be an industrial process, an individual heat and electricity consumer, a district heating/cooling system, and/or the electric grid. In all cases the consumer area uses the energy outputs from the cogeneration unit (See Figure 2).

Figure 2

Area of cogeneration unit

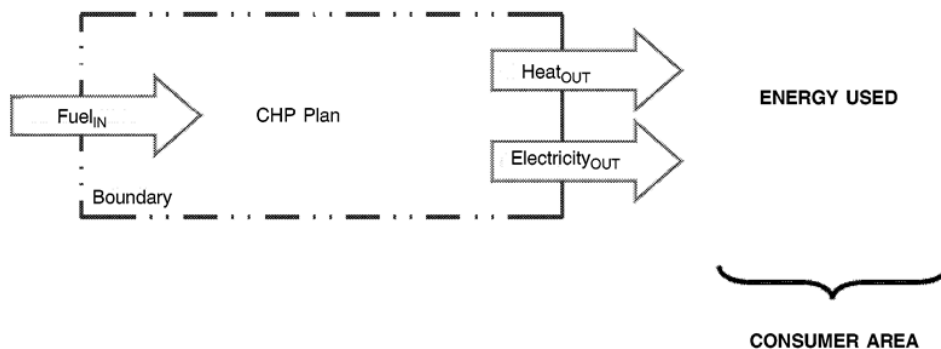

3. The CHP electricity output shall be measured at the generator terminals and any internal consumption for the operation of the cogeneration unit shall not be removed. The power output shall not be reduced by the electrical power used internally.

4. Other heat or electricity production equipment such as heat-only-boilers and electricity-only-power units that do not contribute to a cogeneration process shall not be included as part of the cogeneration unit as illustrated in Figure 3.

Figure 3 Selection of the correct system boundaries in case of auxiliary/stand by boilers (GT: Gas Turbine; G: Generator; FB: Fuel Boiler; HRB: Heat Recovery Boiler)

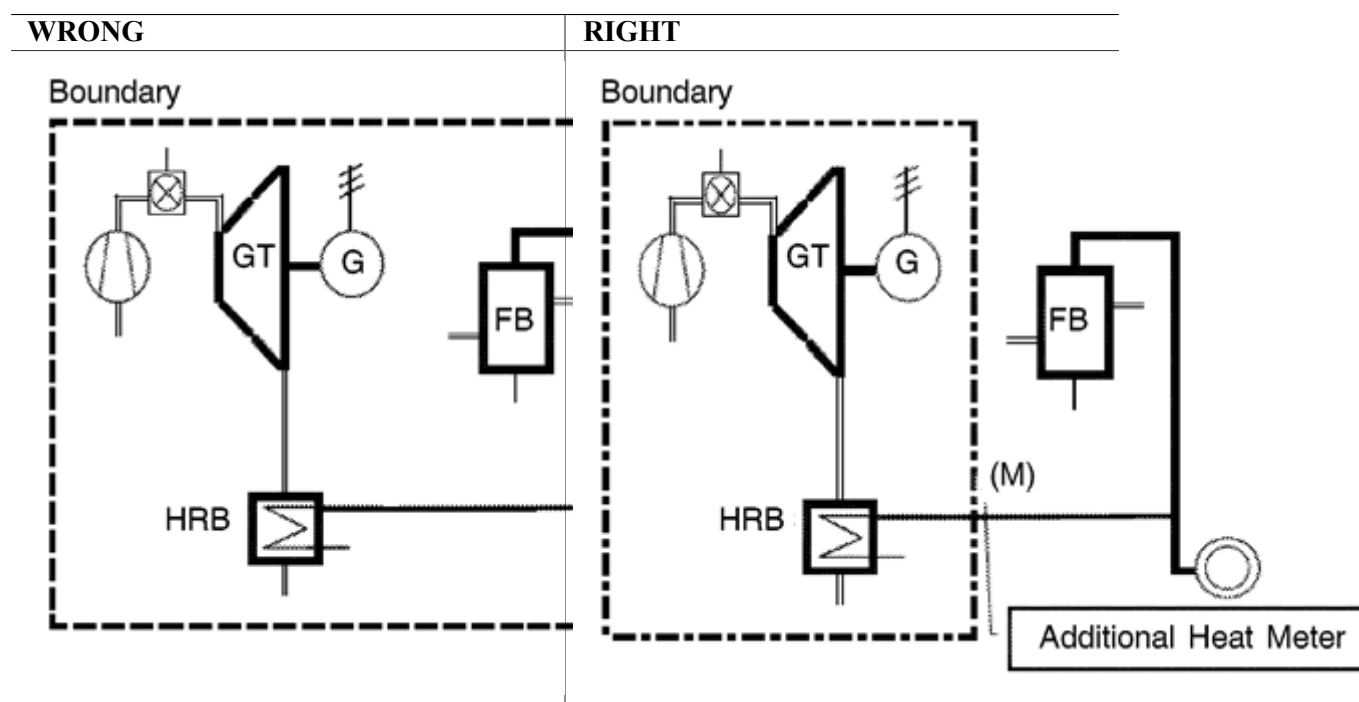

5. The secondary steam turbines (see Figure 4) must be included as part of the cogeneration unit. The electrical energy output of a secondary steam turbine forms part of the energy outputs from the cogeneration unit. The thermal energy required to produce these additional electrical energy outputs has to be excluded from the useful heat output of the cogeneration unit as a whole.

Figure 4 Selection of the correct system boundaries in the case of secondary steam turbines (ST: Steam Turbine)

WRONG	RIGHT
-------	-------

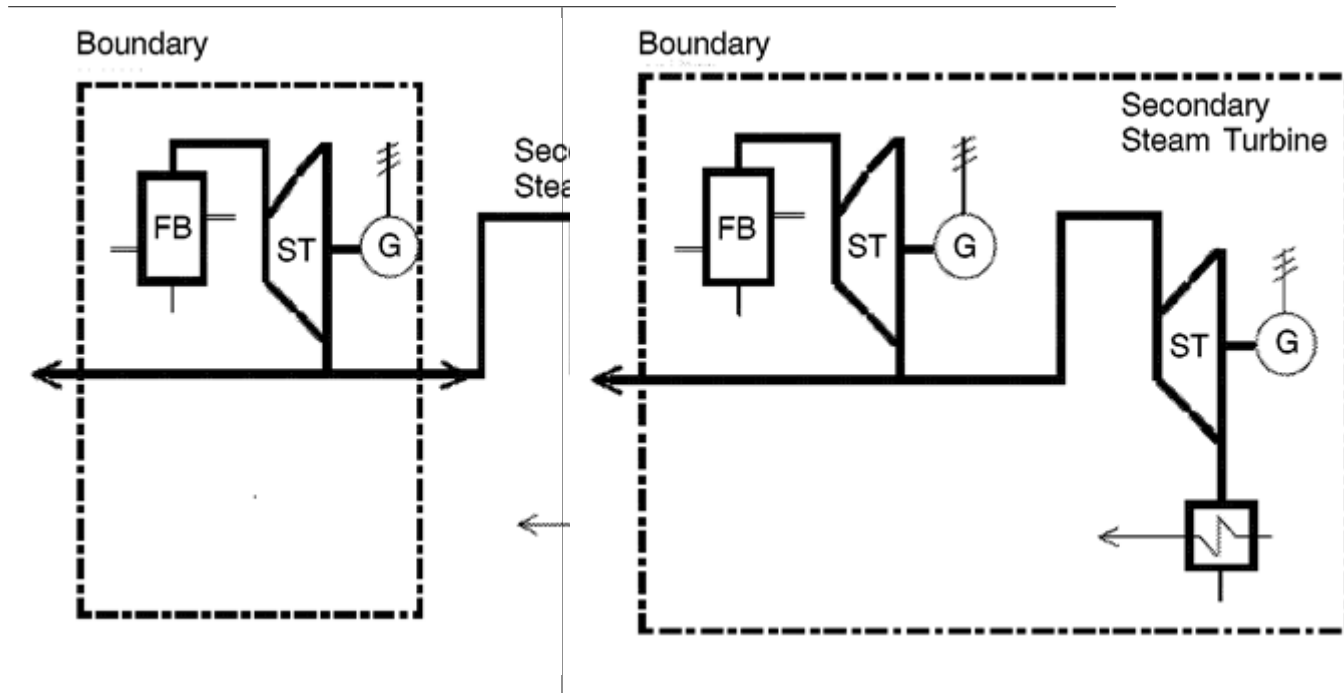

6. Where prime movers (i.e. engine or turbine) are connected in series (where the heat from one prime mover is converted to steam to supply a steam turbine), the prime movers cannot be considered separately, even if the steam turbine is located on a different site (see Figure 5).

Figure 5

Boundary of cogeneration unit for connected prime movers

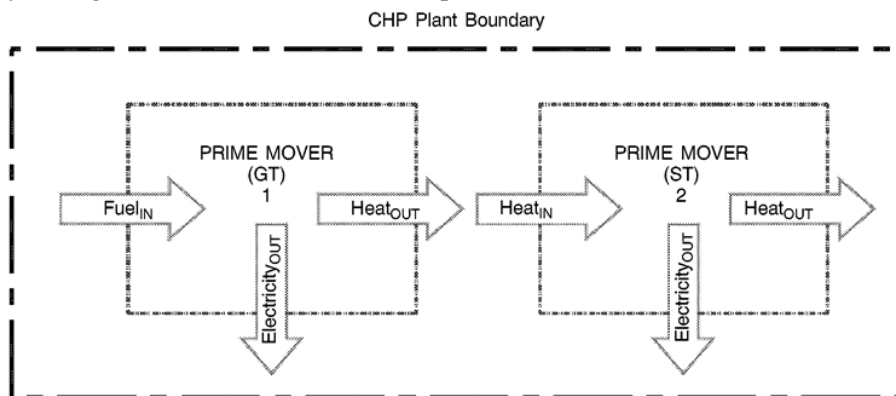

7. When the first prime mover is not producing electricity or mechanical energy, the boundary of the cogeneration unit is around the second prime mover. The fuel input for this second prime mover is the heat output of the first prime mover.

- (1) [OJ L 52, 21.2.2004, p. 50.](#)
- (2) The mechanical energy is treated thermodynamically equivalent to electricity with a factor of 1.
- (3) Except for micro-cogeneration units, see Step 2 (point 6.2).
- (4) Including unavoidable thermal energy losses and ‘non-economically justifiable demanded’ heat produced by the co-generation unit.
- (5) Fuel inputs should be measured in equivalent units referred to the main fuel used to produce these fuel inputs.
- (6) The power to heat ratio used to calculate the CHP electricity can be used also to calculate the CHP electrical capacity if the unit cannot be operated in a full cogeneration mode, as follows: $P_{CHP} = Q_{CHP} \times C$ where P_{CHP} is the CHP electrical capacity, Q_{CHP} is the CHP heat capacity and C is the power to heat ratio.