

Commission Decision of 21 December 2007 concerning the technical specification of interoperability relating to ‘persons with reduced mobility’ in the trans-European conventional and high-speed rail system (notified under document C(2007) 6633) (Text with EEA relevance) (2008/164/EC) (repealed)

COMMISSION DECISION

of 21 December 2007

concerning the technical specification of interoperability relating to ‘persons with reduced mobility’ in the trans-European conventional and high-speed rail system

(notified under document C(2007) 6633)

(Text with EEA relevance)

(2008/164/EC) (repealed)

THE COMMISSION OF THE EUROPEAN COMMUNITIES,

Having regard to the Treaty establishing the European Community,

Having regard to Directive 2001/16/EC of 19 March 2001 of the European Parliament and of the Council on the interoperability of the conventional rail system⁽¹⁾, and in particular Article 6 (1) thereof,

Having regard to Directive 96/48/EC of 23 July 1996 of the European Parliament and of the Council on the interoperability of the high-speed rail system⁽²⁾, and in particular Article 6 (1) thereof

Whereas:

- (1) In accordance with Article 5(1) of Directive 2001/16/EC, and Article 5(1) of Directive 96/48/EC, each of the subsystems shall be covered by one TSI. Where necessary, a subsystem may be covered by several TSIs and one TSI may cover several subsystems. The decision to develop and/or to review a TSI and the choice of its technical and geographical scope requires a mandate in accordance with Article 6(1) of Directive 2001/16/EC and Article 6(1) of 96/48/EC;
- (2) Annex II of Directive 2001/16/EC provides that the needs of persons with reduced mobility shall be taken into account in the elaboration of a TSI for subsystem Infrastructure (section 2.1 of the Directive) and for subsystem Rolling Stock (section 2.6 of Annex II of the Directive 2001/16/EC). In this respect a mandate was granted to the European Association for Railway Interoperability (AEIF), which was appointed as the joint representative body, to draw up a draft TSI for ‘accessibility for persons with reduced mobility’ containing provisions to be applied to both the infrastructure and rolling stock;
- (3) In 2001 the AEIF were granted a mandate to revise the first set of high speed TSIs which had been adopted in 2002, related to the rolling stock, infrastructure, control-command

and signalling, energy, maintenance, and operation sub-systems. As part of this part the AEIF were asked to consider, amongst other issues, the harmonisation of the TSIs with those on conventional rail interoperability and the accessibility for mobility-impaired persons. For this reason the draft TSI on persons with reduced mobility prepared by the AEIF covered both conventional and high speed rail.

- (4) The first high speed TSI of the rolling stock sub-system, adopted as Annex to Decision 2002/735/EC, came into force in 2002. Due to existing contractual commitments, new rolling stock sub-systems or interoperability constituents, or their renewal and upgrade may today fall under conformity assessment against this first TSI. As this TSI in Annex to this Decision is applicable to all new, renewed and upgraded high speed and conventional rail rolling stock, it is important to determine the scope of applicability of the first high speed rolling stock TSI which was adopted as Annex to Decision 2002/735/EC. Member States shall notify an exhaustive list of subsystems and interoperability constituents which are at an advanced stage of development, and fall under Article 7(a) of Directive 96/48/EC. These shall be notified to the Commission not later than six months after the date on which the present Decision becomes applicable.
- (5) The draft TSI has been examined by the Committee set up by Council Directive 96/48/EC of 23 July 1996 on the interoperability of the trans-European high-speed rail system⁽³⁾ and referred to in Article 21 of Directive 2001/16/EC.
- (6) The main stakeholders have been consulted during the elaboration of the draft TSI. Their observations and concerns have been taken into account wherever possible.
- (7) In its proposal for a Regulation on International Rail Passengers' Rights and Obligations⁽⁴⁾, the Commission included several provisions ensuring that PRMs are given assistance on board of trains and in stations in order to allow them the full benefits of travelling by train as any other citizen;
- (8) The proposal for International Rail Passengers' Rights and Obligations also contains provisions requiring railway undertakings and infrastructure managers to provide all relevant information on the accessibility and access conditions for PRMs of trains and stations;
- (9) The main objective of the underlying Directives 2001/16/EC and 96/48/EC is interoperability. The aim of the TSI is to harmonise the provisions to be made for persons with reduced mobility travelling as passengers on the conventional and high-speed railway system. Train, stations and relevant parts of the infrastructure that comply with the measures described within the TSI will permit interoperability and offer a similar level of access to persons with reduced mobility across the trans-European network. The TSI does not prevent Member States from introducing additional measures for improving access, as long as it does not impede interoperability or place undue cost on Railway Undertakings. Improved accessibility to rolling stock and stations for disabled and persons with reduced mobility could potentially increase the number of passengers that are currently forced to use other modes of transport.
- (10) Directives 2001/16/EC and 96/48/EC and the TSIs do apply to renewals but not to maintenance-related replacements. However Member States are encouraged, when they

are able to do so and where it is justified by the scope of the maintenance-related work, to apply the TSIs to maintenance-related replacements.

- (11) In its current version the TSI does not fully deal with all essential requirements. In accordance with Article 17 of Directive 2001/16/EC, and Article 17 of Directive 96/48/EC, both as modified by Directive 2004/50/EC, technical aspects which are not covered are identified as ‘Open Points’ in Annex L of this TSI.
- (12) In accordance with Article 17 of Directive 2001/16/EC and Article 17 of Directive 96/48/EC, both as modified by Directive 2004/50/EC, individual Member States are to inform the other Member States and the Commission of the relevant national technical rules in use for implementing essential requirements related to these ‘open points’, as well as of the bodies it appoints for carrying out the procedure for the assessment of conformity or suitability for use as well as the checking procedure in use for verifying the interoperability of subsystems within the meaning of Article 16(2) of Directive 2001/16/EC and Article 16(2) of 96/48/EC. For this latter purpose, Member States should apply, as far as possible, the principles and criteria provided for in Directives 2001/16/EC and 96/48/EC. Wherever possible Member States shall make use of the bodies notified under Article 20 of Directive 2001/16/EC and Article 20 of 96/48/EC. The Commission should carry out an analysis of the information forwarded by the Member States, in the form of national rules, procedures, bodies in charge of implementing procedures, and duration of these procedures, and, where appropriate, should discuss with the Committee the need for the adoption of any measures.
- (13) The TSI in question should not demand the use of specific technologies or technical solutions except where this is strictly necessary for the interoperability of the trans-European conventional rail system.
- (14) The TSI is based on best available expert knowledge at the time of preparation of the relevant draft. Developments in technology, operational, safety or social requirements may make it necessary to amend or supplement this TSI. Where applicable, a review or updating procedure should be initiated in accordance with Article 6(3) of Directive 2001/16/EC, or Article 6(3) of Directive 96/48/EC. This review shall involve organisations representing the interests of PRMs;
- (15) To encourage innovation and in order to take into account the experience acquired, the attached TSI should be subject to a periodical revision at regular intervals.
- (16) Where innovative solutions are proposed the manufacturer or the contracting entity shall state the deviation from the relevant section of the TSI. The European Rail Agency will finalise the appropriate functional and interface specifications of the solution and develop the assessment methods.
- (17) The provisions of this Decision are in conformity with the opinion of the Committee set up by Article 21 of Council Directive 96/48/EC,

HAS ADOPTED THIS DECISION:

Article 1

A Technical Specification for Interoperability ('TSI') relating to 'persons with reduced mobility' is hereby adopted by the Commission in accordance with Article 6(1) of the Directive 2001/16/EC and Article 6(1) of Directive 96/48/EC.

The TSI shall be as set out in the Annex to this Decision.

The TSI shall be fully applicable to the trans-European conventional rail system as defined in Article 2 and Annex I to Directive 2001/16/EC, and the trans-European high-speed rail system as defined in Article 2 and Annex I to Directive 96/48/EC.

Article 2

Member States may still apply Commission Decision 2002/735/EC for those projects falling under the scope of Article 7(a) of Directive 96/48/EC.

An exhaustive list of the sub-systems and interoperability constituents to which this is applicable shall be notified to the Commission not later than six months after the date on which this Decision becomes applicable.

Article 3

1 With regard to those issues classified as 'Open points' set out in Annex C of the TSI, the conditions to be complied with for the verification of the interoperability pursuant to Article 16(2) of Directive 2001/16/EC and Article 16(2) of Directive 96/48/EC shall be those applicable technical rules in use in the Member State which authorise the placing in service of the subsystems covered by this Decision.

2 Each Member State shall notify to the other Member States and to the Commission within six months of the notification of this Decision:

- a the list of the applicable technical rules mentioned in paragraph 1;
- b the conformity assessment and checking procedures to be applied with regard to the application of these rules;
- c the bodies it appoints for carrying out those conformity-assessment and checking procedures.

Article 4

This Decision shall apply from 1 July 2008.

Article 5

This Decision is addressed to the Member States.

Done at Brussels, 21 December 2007.

For the Commission

Jacques BARROT

Vice-President of the Commission

ANNEX

TRANS-EUROPEAN CONVENTIONAL AND HIGH-SPEED RAIL SYSTEM TECHNICAL SPECIFICATION FOR INTEROPERABILITY

Scope: Subsystems Infrastructure and Rolling Stock
Aspect: Accessibility for Persons with Reduced Mobility

1. INTRODUCTION

1.1. Technical scope

This TSI covers the Conventional and High Speed Rail Infrastructure and passenger Rolling Stock subsystems as described in Annex I to Directive 2001/16/EC modified by Directive 2004/50/EC, only for the Aspect ‘Accessibility for Persons with Reduced Mobility’. It also deals with some elements of the ‘Telematics Applications for Passengers’ subsystem, such as, for example, ticketing equipment.

The objective of this TSI is to enhance the accessibility of rail transport to the persons with reduced mobility. This includes the accessibility of the public areas of the Infrastructure (including stations) controlled by the Railway Undertaking, Infrastructure Manager or Station Manager. Particular attention is to be devoted to:

- (i) the problems generated by the interface platform-train which require an holistic perspective between Infrastructure Rolling Stock;
- (ii) the needs for evacuation in the case of hazardous situations.

This TSI does not specify operating rules for evacuation, but only technical and professional qualification requirements. Purpose of technical requirements is to facilitate evacuation for all.

Some operating rules not related to evacuation can be found in clauses 4.1.4 and 4.2.4 of this TSI.

This TSI concerns:

- the Conventional Rail Infrastructure subsystem shown in the list in point 1 of Annex II to Directive 2001/16/EC as modified by Directive 2004/50/EC
- the Conventional Rail Rolling Stock subsystem shown in the list in point 1 of Annex II to Directive 2001/16/EC, as modified by Directive 2004/50/EC, only when intended to carry passengers. However, heritage Rolling Stock is specifically excluded from the need to comply at upgrade or renewal.
- the High Speed Rail Infrastructure subsystem shown in the list in point 1 of Annex II to Directive 96/48/EC as modified by Directive 2004/50/EC
- the High Speed Rail Rolling Stock subsystem shown in the list in point 1 of Annex II of Directive 96/48/EC, as modified by Directive 2004/50/EC.
- To a minor extent, the High-Speed and Conventional Rail ‘Telematics Applications for Passengers’ subsystems as identified in Annex II to Directive 96/48/EC as modified by Directive 2004/50/EC, and in Annex II to Directive 2001/16/EC.

Further information on the subsystems is provided in Chapter 2.

1.2. Geographical scope

The geographical scope of this TSI is the trans-European conventional rail system as described in Annex I to Directive 2001/16/modified by Directive 2004/50/EC, and the trans-European high-speed rail system described in Annex I to Directive 96/48/EC as modified by Directive 2004/50/EC.

Reference is made, in particular, to the lines of the conventional and high speed rail network referred to in Decision No 1692/96/EC of the European Parliament and of the Council of 23 July 1996 on Community guidelines for the development of the trans-European transport network, or those included in any update of this Decision resulting from the revision provided for in Article 21 of the Decision, especially Decision No 884/2004/CE of the European Parliament and of the Council of 29 April 2004.

1.3. Content of this TSI

In accordance with Article 5(3) of Directive 2001/16/EC as modified by Directive 2004/50/EC, and Article 5(3) of Directive 96/48/EC as modified by 2004/50/EC, this TSI:

- (a) indicates its intended scope (part of the network or Rolling Stock referred to in Annex I to the Directive; subsystem or part of subsystem referred to in Annex II to the Directive or aspect concerned) — (section 2);
- (b) lays down essential requirements for each subsystem concerned and its interfaces vis-à-vis other subsystems (section 3)
- (c) establishes the functional and technical specifications to be met by the subsystem and its interfaces with other subsystems (section 4).
- (d) determines the interoperability constituents and interfaces which are to be covered by European specifications, including European standards, which are necessary to achieve interoperability within the trans-European conventional rail system (section 5);
- (e) states, in each case under consideration, the procedures for the assessment of conformity or suitability for use. This includes in particular the modules defined in Decision 93/465/EEC or, where appropriate, the specific procedures to be used to assess either the conformity or the suitability for use of interoperability constituents and ‘EC’ verification of subsystems (section 6);
- (f) indicates the strategy for implementing the TSI. In particular, it is necessary to specify the stages to be completed in order to make a gradual transition from the existing situation to the final situation in which compliance with the TSI shall be the norm (section 7);
- (g) indicates, for the staff concerned, the professional qualifications and health and safety conditions at work required for the operation and maintenance of the subsystems, as well as the implementation of the TSI — (section 4).

Moreover, in accordance with Article 5(5), provision may be made for specific cases for each TSI; these are indicated in Section 7.

Lastly, this TSI also comprises, in Section 4, the operating and maintenance rules specific to the scope indicated in clauses 1.1 and 1.2 above.

2. DEFINITION OF SUBSYSTEM/SCOPE

2.1. Definitions of the subsystems

2.1.1. Infrastructure

The track, points, engineering structures (footbridges, tunnels, etc.), associated station Infrastructure (platforms, zones of access, including the needs of persons with reduced mobility, etc.), safety and protective equipment.

This includes the accessibility of the public areas of the Infrastructure (including stations) controlled by the Railway Undertaking, Infrastructure Manager or Station Manager.

This TSI is only applicable to the public areas of the stations and their zones of access controlled by the Railway Undertaking, Infrastructure Manager or Station Manager.

2.1.2. Rolling Stock

Structure, command and control system for all train equipment, traction and energy conversion units, braking, coupling and running gear (bogies, axles, etc.) and suspension, doors, man/machine interfaces (driver, on-board staff and passengers, including the needs of persons with reduced mobility), passive or active safety devices and requisites for the health of passengers and on-board staff.

2.1.3. Telematics Applications for Passengers

Applications for passenger services, including systems providing passengers with information before and during the journey, reservation and payment systems, luggage management and management of connections between trains and with other modes of transport.

2.2. Definition of ‘persons with reduced mobility’

‘Persons with Reduced Mobility’ (PRM) means all people who have difficulty when using trains or the associated Infrastructure. This includes the following categories:

- Wheelchair users (persons who due to infirmity or disability use a wheelchair for mobility)
- Other mobility impaired including:
 - people with limb impairment;
 - people with ambulant difficulties;
 - people with children;
 - people with heavy or bulky luggage;
 - elderly people;
 - pregnant women.
- Visually impaired.
- Blind people.
- Hearing impaired.
- Deaf people.
- Communication impaired (meaning persons who have difficulty in communicating or understanding the written, or spoken language, and including foreign people with lack of knowledge of the local language, people with communication difficulties, people with sensory, psychological and intellectual impairments).
- People of small stature (including children).

Impairments may be long-term or temporary, and may be visible or hidden.

However, PRM does not include people that are alcohol or drug dependent, unless such dependency has been caused by medical treatment.

The transport of oversized items (for example: bicycles and bulky luggage) is not within the scope of this TSI. These are subject to the rules, safety requirements and commercial decisions, of the Infrastructure Manager, Station Manager or Railway Undertaking in terms of permitted size, weight and security arrangements.

3. ESSENTIAL REQUIREMENTS

3.1. General

In the scope of this TSI, fulfilment of relevant essential requirements quoted in Section 3 of this TSI will be ensured by the compliance with the specifications described:

- in Section 4 for the subsystem,
- and in Section 5 for the interoperability constituents,

as demonstrated by a positive result of the assessment of:

- conformity and/or suitability for use of the interoperability constituents
- and verification of the subsystem.

as described in Section 6.

Parts of the essential requirements are covered by National Rules because of:

- lack of specification for points listed in Annex L;
- derogation under Art. 7 of the Directive 2001/16/EC;
- specific cases described in clause 7.3 of the present TSI.

The corresponding conformity assessment shall be carried out according to procedures that are defined by a Member State that has notified the National Rules or asked for the derogation or the specific case.

Under to Article 4(1) of Directive 2001/16/EC modified by Directive 2004/50/EC, the Trans-European high-speed rail system, subsystems and their interoperability constituents shall meet the essential requirements set out in general terms in Annex III of the Directive.

Conformity of the Infrastructure and Rolling Stock subsystems and their constituents to the essential requirements are checked in accordance with the provisions envisaged in Directive 2001/16/EC modified by Directive 2004/50/EC as well as in this TSI.

3.2. The essential requirements relate to:

- safety;
- reliability and availability;
- health;
- environmental protection;
- technical compatibility.

These requirements include general requirements and requirements specific to each subsystem. In accordance with Directive 2001/16/EC modified by Directive 2004/50/EC Annex II Infrastructure and Rolling Stock are subsystems classified under 'structural areas'. The relevant subsystem descriptions are as follows, which in both cases specifically refer to the needs of PRM:

Infrastructure:

The track, points, engineering structures (footbridges, tunnels, etc.), associated station Infrastructure (platforms, zones of access, including the needs of persons with reduced mobility, etc.), safety and protective equipment.

Rolling Stock:

Structure, command and control system for all train equipment, traction and energy conversion units, braking, coupling and running gear (bogies, axles, etc.) and suspension, doors, man/machine interfaces (driver, on-board staff and passengers, including the needs of persons with reduced mobility), passive or active safety devices and requisites for the health of passengers and on-board staff.

Essential requirements listed below are according to Annex III to Directive 2001/16/EC modified by Directive 2004/50/EC, which is the last published.

3.3. General requirements

3.3.1. Safety

Essential Requirement 1.1.1 of Annex III to Directive 2001/16/EC modified by Directive 2004/50/EC:

The design, construction or assembly, maintenance and monitoring of safety-critical components and, more particularly, of the components involved in train movements must be such as to guarantee safety at the level corresponding to the aims laid down for the network, including those for specific degraded situations.

This essential requirement is satisfied by the functional and technical specifications in clauses:

- 4.1.2.4 (Infrastructure — Doors and entrances)
- 4.2.2.4 (Rolling Stock — Doors)
- 4.2.2.4.2 (Rolling Stock — Exterior doors)
- 4.2.2.4.3 (Rolling Stock — Interior doors)
- 4.2.2.9 (Rolling Stock — Height changes)
- 4.2.2.10 (Rolling Stock — Handrails)
- 4.2.2.12 (Rolling Stock — Step position and vehicle access and egress)
- 4.2.2.12.1 (Rolling Stock — General requirements)
- 4.2.2.12.2 (Rolling Stock — Access/egress steps)
- 4.2.2.12.3 (Rolling Stock — Boarding aids for passengers using wheelchairs)
- 4.1.2.21 (Infrastructure — Boarding aids)

Essential Requirement 1.1.5 of Annex III to Directive 2001/16/EC modified by Directive 2004/50/EC:

Any devices intended to be handled by users must be so designed as not to impair the safe operation of the devices or the health and safety of users if used foreseeably in a manner not in accordance with the posted instructions.

This essential requirement is satisfied by the functional and technical specifications in clauses:

- 4.2.2.4 (Rolling Stock — Doors)
- 4.2.2.4.2 (Rolling Stock — Exterior doors)
- 4.2.2.4.3 (Rolling Stock — Interior doors)

3.3.2. Reliability and availability

Essential Requirement 1.2 of Annex III to Directive 2001/16/EC modified by Directive 2004/50/EC:

The monitoring and maintenance of fixed or movable components that are involved in train movements must be organised, carried out and quantified in such a manner as to maintain their operation under the intended conditions.

This essential requirement is satisfied by the functional and technical specifications in clauses:

- 4.2.2.4 (Rolling Stock — Doors, exterior & interior)
- 4.2.2.4.2 (Rolling Stock — Exterior doors)
- 4.2.2.4.3 (Rolling Stock — Interior doors)

3.3.3. Health

Essential Requirement 1.3.1 of Annex III to Directive 2001/16/EC modified by Directive 2004/50/EC:

Materials likely, by virtue of the way they are used, to constitute a health hazard to those having access to them must not be used in trains and railway Infrastructure.

This essential requirement is satisfied by the functional and technical specifications in clauses:

- 4.2.2.2 (Rolling Stock — Seats)
- 4.2.2.2.1 (Rolling Stock — General)
- 4.2.2.2.2 (Rolling Stock — Priority Seats)
- 4.2.2.7 (Rolling Stock — Clearways)

3.3.4. Environmental protection

Not relevant for this TSI

3.3.5. Technical compatibility

Essential Requirement 1.5 of Annex III to Directive 2001/16/EC modified by Directive 2004/50/EC:

The technical characteristics of the Infrastructure and fixed installations must be compatible with each other and with those of the trains to be used on the trans-European conventional rail system.

'If compliance with these characteristics proves difficult on certain sections of the network, temporary solutions, which ensure compatibility in the future, may be implemented.'

This essential requirement is satisfied by the functional and technical specifications in clauses:

- 4.1.2.18 (Infrastructure — Platform height and offset)
- 4.2.2.12 (Rolling Stock — Step position for vehicle access and egress)

3.4. Requirements specific to the Infrastructure subsystem

3.4.1. Safety

Essential Requirement 2.1.1 of Annex III to Directive 2001/16/EC modified by Directive 2004/50/EC:

Steps must be taken to limit the dangers to which persons are exposed, particularly when trains pass through stations.

This essential requirement is satisfied by the functional and technical specifications in clauses:

- 4.1.2.19 (Infrastructure — Platform width and edge of platform)

Infrastructure to which the public has access must be designed and made in such a way as to limit any human safety hazards (stability, fire, access, evacuation, platforms, etc.).

This essential requirement is satisfied by the functional and technical specifications in clauses:

- 4.1.2.3 (Infrastructure — Obstacle-free routes)
- 4.1.2.3.1 (Infrastructure — General)
- 4.1.2.3.2 (Infrastructure — Route identification)
- 4.1.2.4 (Infrastructure — Doors and Entrances)
- 4.1.2.5 (Infrastructure — Floor Surfaces)

- 4.1.2.6 (Infrastructure — Transparent obstacles)
- 4.1.2.8 (Infrastructure — Furniture and free-standing devices)
- 4.1.2.9 (Infrastructure — Ticketing, information desks and customer assistance points)
- 4.1.2.10 (Infrastructure — Lighting)
- 4.1.2.12 (Infrastructure — Spoken Information)
- 4.1.2.13 (Infrastructure — Emergency exits)
- 4.1.2.14 (Infrastructure — Geometry of footbridges and subways)
- 4.1.2.15 (Infrastructure — Stairs)
- 4.1.2.16 (Infrastructure — Handrails)
- 4.1.2.17 (Infrastructure — Ramps, escalators, lifts and travelators)
- 4.1.2.18 (Infrastructure — Platform height and offset)
- 4.1.2.19 (Infrastructure — Platform width and edge of platform)
- 4.1.2.20 (Infrastructure — Edge of platform)
- 4.1.2.21 (Infrastructure — Boarding aids)
- 4.1.2.22 (Infrastructure — Level track crossing at stations)

3.5. Requirements specific to the Rolling Stock subsystem

3.5.1. Safety

Essential Requirement 2.4.1 of Annex III to Directive 2001/16/EC modified by Directive 2004/50/EC:

The structure of the Rolling Stock and of the links between vehicles must be designed in such a way as to protect the passenger and driving compartments in the event of collision or derailment.

This essential requirement is satisfied by the functional and technical specifications in clauses:

- 4.2.2.3 (Rolling Stock — Wheelchairs spaces)

Steps must be taken to prevent access to electrically-live constituents in order not to endanger the safety of persons.

This essential requirement is not relevant within in the scope of this TSI.

In the event of danger, devices must enable passengers to inform the driver and accompanying staff to contact him.

This essential requirement is satisfied by the functional and technical specifications in clauses:

- 4.2.2.3 (Rolling Stock — Wheelchair spaces)
- 4.2.2.6.3 (Rolling Stock — Universal toilet)
- 4.2.2.11 (Rolling Stock — Wheelchair accessible sleeping accommodation)

The access doors must incorporate an opening and closing system which guarantees passenger safety.

This essential requirement is satisfied by the functional and technical specifications in clauses:

- 4.2.2.4.2 (Doors — Exterior doors)

Emergency exits must be provided and indicated.

This essential requirement is satisfied by the functional and technical specifications in clauses:

- 4.2.2.4.2 (Rolling Stock — Exterior doors)
- 4.2.2.8 (Rolling Stock — Customer information)

An emergency lighting system of sufficient intensity and duration is compulsory on trains

This essential requirement is satisfied by the functional and technical specifications in clauses:

- 4.2.2.5 (Rolling Stock — Lighting)

Trains must be equipped with a public address system which provides a means of communication to the public from on-board staff and ground control.

This essential requirement is satisfied by the functional and technical specifications in clause:

- 4.2.2.8 (Rolling Stock — Customer Information)
- 4.2.2.8.2 (Rolling Stock — Information (signage and pictograms))

3.5.2. Reliability and availability

Essential Requirement 2.4.2 of Annex III to Directive 2001/16/EC modified by Directive 2004/50/EC:

The design of the vital equipment, of the running, traction and braking equipment and of the control and command system must be such as to enable the train to continue its mission, in a specific degraded situation, without adverse consequences for the equipment remaining in service.

This essential requirement is satisfied by the functional and technical specifications in clauses:

- 4.2.2.12.3 (Rolling Stock — Boarding and alighting devices for passengers using wheelchairs)
- 4.2.2.12.3.5 (Rolling Stock — Moveable steps)

3.5.3. Technical compatibility

Essential Requirement 2.4.3 of Annex III to Directive 2001/16/EC modified by Directive 2004/50/EC:

The electrical equipment must be compatible with the operation of the control and command and signalling installations.

This essential requirement is not relevant within in the scope of this TSI.

In the case of electric traction, the characteristics of the current-collection devices must be such as to enable trains to travel under the energy-supply systems for the trans-European conventional rail system.

This essential requirement is not relevant within the scope of this TSI.

The characteristics of the Rolling Stock must be such as to allow it to travel on any line on which it is expected to operate.

This essential requirement is satisfied by the functional and technical specifications in clause:

- 4.2.2.12 (Rolling Stock — Step position for vehicle access and egress)

3.6. Requirements specific to other subsystems concerning also the Infrastructure and Rolling Stock subsystem

3.6.1. Energy Subsystem

3.6.1.1. Safety

Essential Requirement 2.2.1 of Annex III to Directive 2001/16/EC modified by Directive 2004/50/EC:

Operation of the energy-supply systems must not impair the safety either of trains or of persons (users, operating staff, trackside dwellers and third parties).

This essential requirement is not relevant within the scope of this TSI.

3.6.1.2. Environmental protection

Essential Requirement 2.2.2 of Annex III to Directive 2001/16/EC modified by Directive 2004/50/EC:

The functioning of the electrical or thermal energy-supply systems must not interfere with the environment beyond the specified limits.

This essential requirement is not relevant within the scope of this TSI.

3.6.1.3. Technical compatibility

Essential Requirement 2.2.3 of Annex III to Directive 2001/16/EC modified by Directive 2004/50/EC:

The electricity/thermal energy supply systems used must:

- *enable trains to achieve the specified performance levels;*
- *in the case of electricity energy supply systems, be compatible with the collection devices fitted to the trains.*

This essential requirement is not relevant within the scope of this TSI.

3.6.2. Control and command and signalling

3.6.2.1. Safety

Essential Requirement 2.3.1 of Annex III to Directive 2001/16/EC modified by Directive 2004/50/EC:

The control and command and signalling installations and procedures used must enable trains to travel with a level of safety which corresponds to the objectives set for the network. The control and command and signalling systems should continue to provide for safe passage of trains permitted to run under degraded conditions.

This essential requirement is not relevant within the scope of this TSI.

3.6.2.2. Technical compatibility

Essential Requirement 2.3.2 of Annex III to Directive 2001/16/EC modified by Directive 2004/50/EC:

All new Infrastructure and all new Rolling Stock manufactured or developed after adoption of compatible control and command and signalling systems must be tailored to use of those systems.

This essential requirement is not relevant within the scope of this TSI.

The control and command and signalling equipment installed in the train drivers' cabs must permit normal operation, under the specified conditions, throughout the trans-European conventional rail system.

This essential requirement is not relevant within the scope of this TSI.

3.6.3. Maintenance

3.6.3.1. Health and safety

Essential Requirement 2.5.1 of Annex III to Directive 2001/16/EC modified by Directive 2004/50/EC:

The technical installations and the procedures used in the centres must ensure the safe operation of the subsystem and not constitute a danger to health and safety.

This essential requirement is not relevant within the scope of this TSI.

3.6.3.2. Environmental protection

Essential Requirement 2.5.2 of Annex III to Directive 2001/16/EC modified by Directive 2004/50/EC:

The technical installations and the procedures used in the maintenance centres must not exceed the permissible levels of nuisance with regard to the surrounding environment.

This essential requirement is not relevant within the scope of this TSI.

3.6.3.3. Technical compatibility

Essential Requirement 2.5.3 of Annex III to Directive 2001/16/EC modified by Directive 2004/50/EC:

The maintenance installations for conventional Rolling Stock must be such as to enable safety, health and comfort operations to be carried out on all stock for which they have been designed.

This essential requirement is not relevant within the scope of this TSI.

3.6.4. Operation and traffic management

3.6.4.1. Safety

Essential Requirement 2.6.1 of Annex III to Directive 2001/16/EC modified by Directive 2004/50/EC:

Alignment of the network operating rules and the qualifications of drivers and on-board staff and of the staff in the control centres must be such as to ensure safe operation, bearing in mind the different requirements of cross-border and domestic services.

This essential requirement is satisfied by the functional and technical specifications in clauses:

- 4.1.4 (Infrastructure — Operational rules)
- 4.1.6 (Infrastructure — Professional qualifications)
- 4.2.4 (Rolling Stock — Operational rules)
- 4.2.6 (Rolling Stock — Professional qualifications)

The maintenance operations and intervals, the training and qualifications of the maintenance and control centre staff and the quality assurance system set up by the operators concerned in the control and maintenance centres must be such as to ensure a high level of safety.

This essential requirement is satisfied by the functional and technical specifications in clauses:

- 4.1.4 (Infrastructure — Operational rules)
- 4.1.6 (Infrastructure — Professional qualifications)
- 4.2.4 (Rolling Stock — Operational rules)
- 4.2.6 (Rolling Stock — Professional qualifications)

3.6.4.2. Technical compatibility

Essential Requirement 2.6.3 of Annex III to Directive 2001/16/EC modified by Directive 2004/50/EC:

Alignment of the network operating rules and the qualifications of drivers, on-board staff and traffic managers must be such as to ensure operating efficiency on the trans-European conventional rail system, bearing in mind the different requirements of cross-border and domestic services.

This essential requirement is satisfied by the functional and technical specifications in clauses:

- 4.1.4 (Infrastructure — Operational rules)
- 4.1.6 (Infrastructure — Professional qualifications)
- 4.2.4 (Rolling Stock — Operational rules)
- 4.2.6 (Rolling Stock — Professional qualifications)

3.6.5. Telematics applications for freight and passengers

3.6.5.1. Technical compatibility

Essential Requirement 2.7.1 of Annex III to Directive 2001/16/EC modified by Directive 2004/50/EC:

The essential requirements for telematics applications guarantee a minimum quality of service for passengers and carriers of goods, particularly in terms of technical compatibility.

Steps must be taken to ensure:

- *that the databases, software and data communication protocols are developed in a manner allowing maximum data interchange between different applications and operators, excluding confidential commercial data;*
- *easy access to the information for users.*

This essential requirement is satisfied by the functional and technical specifications in clauses:

- 4.1.2.9 (Infrastructure — Ticketing, information desks and customer assistance points)
- 4.1.2.11 (Infrastructure — Visual Information, signposting, pictograms and dynamic information)
- 4.1.2.12 (Infrastructure — Spoken information)
- 4.2.2.8 (Rolling Stock — Customer information)

3.6.5.2. Health

Essential Requirement 2.7.3 of Annex III to Directive 2001/16/EC modified by Directive 2004/50/EC:

The interfaces between these systems and users must comply with the minimum rules on ergonomics and health protection

This essential requirement is satisfied by the functional and technical specifications in clauses:

- 4.1.2.9 (Infrastructure — Ticketing, information desks and customer assistance points)
- 4.1.2.12 (Infrastructure — Spoken information)
- 4.2.2.8 (Rolling Stock — Customer information)

3.7. Elements of the PRM TSI domain related to the essential requirements

Status: This is the original version (as it was originally adopted).

Infrastructure		Reference to Clause of Directive 2001/16/EC modified by Directive 2004/50/EC					
		Annex II	Essential Requirement in Annex III				
Element of the PRM TSI Domain	Ref. §		Safety	Reliability and Availability	Health	Environmental protection	Technical compatibility
General	4.1.2.1	2.1					
Parking facilities for PRM	4.1.2.2	2.1					
Obstacle-free routes	4.1.2.3	2.1	2.1.1				
General	4.1.2.3.1	2.1	2.1.1				
Route identification	4.1.2.3.2	2.1	2.1.1				
Doors and entrances	4.1.2.4	2.1	1.1.1 2.1.1				
Floor surfaces	4.1.2.5	2.1	2.1.1				
Transparent obstacles	4.1.2.6	2.1	2.1.1				
Toilets and baby changing facilities	4.1.2.7	2.1	1.1.5 2.1.1				
Furniture and free-standing devices	4.1.2.8	2.1	2.1.1				
Ticketing, information desks and customer assistance points	4.1.2.9	2.1	2.1.1	2.7.3			2.7.1
Lighting	4.1.2.10	2.1	2.1.1				
Visual information: signposting, pictograms,	4.1.2.11	2.1					2.7.1

dynamic information							
Spoken information	4.1.2.12	2.1	2.1.1	2.7.3			2.7.1
Emergency exits, alarms	4.1.2.13	2.1	2.1.1				
Geometry of footbridges and subways	4.1.2.14	2.1	2.1.1				
Stairs	4.1.2.15	2.1	2.1.1				
Handrails	4.1.2.16	2.1	2.1.1				
Ramps, escalators, lifts travelators	4.1.2.17	2.1	2.1.1				
Platform height and offset	4.1.2.18	2.1	2.1.1				1.5
Platform height	4.1.2.18.1	2.1	2.1.1				1.5
Platform offset	4.1.2.18.2	2.1	2.1.1				1.5
Track layout along the platforms	4.1.2.18.3	2.1	2.1.1				1.5
Platform width and edge of platform	4.1.2.19	2.1	2.1.1				
End of platform	4.1.2.20	2.1	2.1.1				
Boarding aids for passengers using wheelchairs	4.1.2.21	2.1	1.1.1				
Level track crossing at stations	4.1.2.22	2.1	2.1.1				

Status: This is the original version (as it was originally adopted).

Rolling Stock		Reference to Clause of Directive 2001/16/EC modified by Directive 2004/50/EC					
		Annex II	Essential Requirement in Annex III				
Element of the PRM TSI Domain	Ref. §		Safety	Reliability and Availability	Health	Environmental protection	Technical compatibility
General	4.2.2.1	2.6					
Seats	4.2.2.2	2.6			1.3.1		
General	4.2.2.2.1	2.6			1.3.1		
Priority seats	4.2.2.2.2	2.6			1.3.1		
Wheelchair spaces	4.2.2.3	2.6	2.4.1				
Doors	4.2.2.4	2.6	1.1.1 1.1.5	1.2			
Exterior doors	4.2.2.4.2	2.6	1.1.1 1.1.5 2.4.1	1.2			
Interior doors	4.2.2.4.3	2.6	1.1.1 1.1.5	1.2			
Lighting	4.2.2.5	2.6	2.4.1				
Toilets	4.2.2.6	2.6	2.4.1				
General	4.2.2.6.1	2.6	2.4.1				
Standard toilet	4.2.2.6.2	2.6	2.4.1				
Universal toilet	4.2.2.6.3	2.6	2.4.1				
Clearways	4.2.2.7	2.6			1.3.1		
Customer information	4.2.2.8	2.6	2.4.1	2.7.3			2.7.1
General	4.2.2.8.1	2.6					
Information (signage and pictograms)	4.2.2.8.2	2.6	2.4.1				
Information (route description and seat reservation)	4.2.2.8.3	2.6					

Height changes	4.2.2.9	2.6	1.1.5				
Handrails	4.2.2.10	2.6	1.1.5				
Wheelchair accessible sleeping accommodation	4.2.2.11	2.6	2.4.1				
Step position for vehicle access and egress	4.2.2.12	2.6	1.1.1				1.5 2.4.3
General requirements	4.2.2.12.1	2.6	1.1.1				1.5 2.4.3
Access/ egress steps	4.2.2.12.2	2.6	1.1.1				1.5 2.4.3
Boarding aids	4.2.2.12.3	2.6	1.1.1	2.4.2			1.5 2.4.3

4. CHARACTERISATION OF THE SUBSYSTEMS

4.1. Subsystem Infrastructure

4.1.1. Introduction

The trans-European conventional rail system, to which Directive 2001/16/EC modified by Directive 2004/50/EC applies and of which the subsystem is a part, is an integrated system whose consistency shall be verified. This consistency shall be checked in particular with regard to the specifications of each subsystem, its interfaces vis-à-vis the system in which it is integrated as well as the operating and maintenance rules.

The functional and technical specifications of the subsystem and its interfaces, described in section 4.1.2, do not impose the use of specific technologies or technical solutions, except where this is strictly necessary for the interoperability of the trans-European conventional rail network. But innovative solutions for interoperability may require new specifications and/or new assessment methods. In order to allow technological innovation, these specifications and assessment methods shall be developed by the process described in sections 6.1.4 and 6.2.4.

Taking account of all the applicable essential requirements, the Infrastructure subsystem is characterised by:

4.1.2. Functional and technical specifications

4.1.2.1. General

In light of the essential requirements in Section 3, the functional and technical specifications of the subsystem Infrastructure related to Accessibility for Persons with Reduced Mobility are arranged as follows:

Status: This is the original version (as it was originally adopted).

- Parking facilities for PRM
- Doors and single level entrances
- Passenger routes, main walking routes
- Floor surfaces
- Tactile information
- Guiding paths
- Glass door and wall markings
- Toilets
- Furniture
- Ticketing counter or vending machines/Information counters
- Ticket control machines
- Lighting
- Visual information: signposting, pictograms, dynamic information
- Spoken information
- Emergency exits, alarms
- Geometry of footbridges and subways
- Stairs
- Handrails
- Ramps, escalators, lifts, travelators
- Platform heights and offsets
- Platform widths and edges of platforms
- Ends of platforms
- Boarding aids
- Level track crossings

For each basic parameter a general clause introduces the subject.

The following clauses then detail the conditions to be met in order to fulfil the requirements introduced in the general clause.

4.1.2.2. Parking facilities for PRM

Where a station specific parking area exists, there shall be parking spaces reserved for PRM eligible to utilise disabled parking spaces at the nearest practicable position, within the parking area, to an accessible entrance.

There are no other Railway specific requirements as European or National Rules shall apply to parking spaces (this includes, but is not limited to: — the number of spaces, access, location, dimensions, materials, colours, signing and lighting).

4.1.2.3. Obstacle-free route

4.1.2.3.1. General

An obstacle free route is a route that can be freely navigated by all categories of PRM. It may include ramps or lifts where these are constructed and operated in accordance with Clause 4.1.2.17.

A minimum of one obstacle free route shall be provided that interconnects the following points and services if provided:

- Stopping points for other connecting modes of transport within the station confines (for example, taxi, bus, tram, metro, ferry etc.);

- Car parks
- Accessible entrances and exits
- Information desks
- Other information systems
- Ticketing facilities
- Customer assistance
- Waiting areas
- Left luggage facilities;
- Toilet facilities
- Platforms

All obstacle-free routes, stairs, footbridges and subways, shall have a free width of a minimum of 1 600 mm, with a minimum headroom of 2 300 mm over the entire width of 1 600 mm. The minimum width requirement does not take into account additional width that may be required for passenger flows. This requirement is not applicable to escalators, travelators and lifts.

The length of the obstacle-free routes shall be the shortest practical distance.

Obstacle-free routes floor surfaces shall have anti-reflecting properties.

New stations with a throughput of less than 1 000 passengers per day (combined total of passengers embarking and disembarking) are not required to have lifts or ramps where these would otherwise be necessary to achieve full compliance with this clause if another station within 30 km on the same route provides a fully compliant obstacle-free route. In such circumstances the design of new stations shall incorporate provision for the future installation of a lift and/or ramps to make the station accessible to all categories of PRM.

4.1.2.3.2. Route identification

Obstacle-free routes shall be clearly identified by visual information as detailed in clause 4.1.2.11.

Information on the obstacle-free route shall be given to visually impaired people by a minimum of one of the following means: e.g. tactile paths, audible, tactile signs, talking signs, Braille maps.

If a tactile path is installed it shall comply with National Rules and shall be provided along the full length of the obstacle-free route(s).

If there are handrails or walls within reach along the obstacle-free route to the platform, they shall have brief information (for example platform-number or direction-information) in Braille and in prismatic-letters or numbers at the rear of the handrail, or on the wall at a height between 850 mm and 1 000 mm. Numbers and arrows are the only permissible tactile pictograms.

4.1.2.4. Doors and entrances

This clause applies to all doors and entrances that are on obstacle-free routes.

A minimum of one accessible entrance to the station, and one accessible entrance to the platforms shall be provided.

Doors and entrances shall have a minimum clear opening width of 800 mm, free headroom of 2 100 mm.

It is permitted to use either manual, semi-automatic or automatic doors.

Door operating devices shall be available at a height of between 800 mm and 1 200 mm.

Manual, non-sliding doors shall be provided with horizontal push bars, extending across the full width of the door, on both sides of the door.

Automatic and semi-automatic doors shall incorporate devices that prevent passengers becoming trapped during operation of the doors.

If pushbuttons or other remote control devices are provided for operation of doors then each pushbutton or device shall contrast with its surroundings and shall be operable by a force not greater than 15 Newtons.

If both open and closed pushbuttons are fitted one above the other, the top button shall always be the open control.

The centre of the control shall be not less than 800 mm and not more than 1 200 mm vertically above floor level.

Such controls shall be identifiable by touch (for example tactile markings) and shall indicate the functionality.

The force required to open or close a manual door, under wind-free conditions, shall not exceed 25 Newtons.

To latch or unlatch a manual door the handle shall be operable by the palm of the hand exerting a force not exceeding 20 Newtons.

Where a revolving door is used, an additional non-revolving door shall be provided, that is freely available for use, adjacent to the revolving door.

At doors and entrances thresholds shall not be higher than 25 mm. Where thresholds are installed, they shall contrast in colour with the immediate background.

4.1.2.5. Floor surfaces

All floor surfaces shall be slip resistant in accordance with National Rules for public buildings.

Within the station buildings there shall be no irregularities in excess of 5 mm at any given point in floor walking surface areas, except for tactile guiding paths, drainage channels and tactile warning indicators.

4.1.2.6. Transparent obstacles

Transparent obstacles on or along the main routes used by passengers, consisting of glass doors or transparent walls, shall be marked with at least two prominent bands made of signs, logos, emblems or decorative features at a height between 1 500 mm and 2 000 mm for one line, and between 850 mm and 1 050 mm for the other line. These markings shall contrast with the background against which they are viewed. These markings shall be a minimum of 100 mm high.

These markings are not required along transparent walls if passengers are protected from impact by other means — for example, by handrails or continuous benches.

4.1.2.7. Toilets and baby-changing facilities

4.1.2.7.1. Subsystem requirements

If toilets are provided at a station, then a minimum of one unisex cubicle shall be wheelchair accessible.

If toilets are provided at a station, baby-changing facilities shall be provided which are accessible to both men and women. They shall comply with requirements of clause 4.1.2.7.2.

In order to allow passengers with bulky luggage to use the toilets, the minimum dimensions of all toilet cubicles shall be 900 mm wide and 1 700 mm length if the door opens inwards, and 1 500 mm length if the door open outwards or is a sliding door. The door and all entrances to the toilet facilities shall have a minimum clear width of 650 mm.

European and National Rules shall apply regarding the dimensions and equipment of toilets for wheelchair users.

4.1.2.7.2. Interoperability constituent requirements Baby-changing facilities

In the useable position, the changing facility shall be between 800 mm and 1 000 mm above floor level. It shall be a minimum of 500 mm wide and 700 mm long.

It shall be designed to prevent a baby from inadvertently sliding off, shall have no sharp edges and shall be able to take a minimum weight of 80 kg.

If the baby-change table protrudes into the accessible toilet space, it shall be possible to put it into the stowed position using a force not exceeding 25 Newtons.

4.1.2.8. Furniture and free-standing devices

All items of furniture and free-standing devices at stations shall contrast with their background, and have rounded edges.

Within the station confines, furniture and free-standing devices shall be positioned where they do not obstruct blind or visually impaired people, and they shall be detectable by a blind person using a stick.

Cantilevered items fitted below a height of 2 100 mm, which protrude by more than 150 mm, shall be indicated by an obstacle, at a maximum height of 300 mm, that can be detected by a blind person using a stick.

There shall be no hanging elements below a height of 2 100 mm.

On each platform where passengers are allowed to wait for trains, and at every resting area, there shall be a minimum of one weather-protected area fitted with ergonomic seating facilities. The seats shall be back supported and at least one third provided with armrests. There shall also be a standing rest bar of at least 1 400 mm length and a space for a wheelchair.

4.1.2.9. Ticketing, Information desks and Customer Assistance points

4.1.2.9.1. Subsystem requirements

Where manual ticket sales counters, information desks and customer assistance points are provided along the obstacle-free route, a minimum of one desk shall be a minimum of 650 mm to the underside of the desk, have a knee well of a minimum of 300 mm deep and have a minimum width of 600 mm. The height of the upper surface, or a part of it with a minimum width of 300 mm and a minimum depth of 200 mm, shall be between 700 mm and 800 mm. This area shall be made available for wheelchair users and alternative seating arrangements shall be provided for other PRM.

If there is a glass barrier between the passenger and sales person at the ticket counter, this shall either be removable or, if not removable, an intercom system shall be fitted. Any such glass barrier shall consist of clear glass.

A minimum of one ticket sales position shall be fitted with the necessary equipment in order to enable a PRM with hearing impairment to understand what is being said by switching their hearing assistance device to the 'T' position.

If electronic devices are fitted that displays pricing information to the sales person, such devices shall also be fitted that display the price to the person purchasing the ticket.

Where ticket vending machines are provided on an obstacle free route at a station, a minimum of one of these machines shall comply with requirements of clause 4.1.2.9.2.

If ticket control machines are fitted, a minimum of one of the machines shall have a free passageway with a minimum width of 800 mm and shall be able to accommodate a wheelchair up to 1 200 mm in length.

If turnstiles are used, there shall be a non-turnstile access point available for use by PRM at all operational times.

4.1.2.9.2. Interoperability constituent requirements

The ticket vending machines to be provided on an obstacle free route at a station according to clause 4.1.2.9.1 shall have the tactile contact area (to include the keyboard, the payment and ticket vending areas) at a height of between 700 mm and 1 200 mm. A minimum of one display and the keyboard shall be visible by both someone sitting in a wheelchair and by someone standing in front of the machine. If the display is the method of entering information then it shall comply with the requirements of this paragraph.

4.1.2.10. Lighting

The station forecourt lighting shall be in accordance with European or National Rules.

From the accessible building entrance to the platform access point, the obstacle-free route shall be illuminated to a minimum of 100 lux, measured at floor level, within the confines of the station building. The minimum required light level on the main entrance, stairs, and at the end of ramps, shall be a minimum of 100 lux measured at floor level. If artificial lighting is required to achieve this, the required lighting level shall be a minimum of 40 lux above the ambient surrounding light levels, and have a colder colour temperature.

Platforms and other external station passenger areas shall have a minimum average illumination level of 20 lux measured at floor level, with a minimum value of 10 lux.

Where artificial lighting is required to allow detailed information to be read, these locations shall be highlighted by lighting with a minimum 15 lux increase over that provided in adjacent areas. Such increased lighting shall also have a different colour temperature to that in the adjacent areas.

Emergency lighting shall be in accordance with European or National Rules.

4.1.2.11. Visual information: signposting, pictograms, dynamic information

4.1.2.11.1 Subsystem requirements

Within a station all information shall be of a consistent nature and in accordance with European or National Rules.

Sans Serif fonts, in mixed case, shall be used for all written information. (i.e. not in capital letters only).

Compressed descenders and ascenders shall not be used.

Descenders shall be clearly recognisable and have a minimum size ratio of 20 % to the upper case characters.

All available information shall be coherent with the general routeing and information system especially with regards to colour and contrast in platforms and entrances

Visual information shall be legible in all lighting conditions when the station is operational.

Visual information shall contrast with its background.

Where dynamic visual information is provided, it shall be consistent with essential spoken information that is being given.

The following information shall be provided:

- Safety Information and Safety Instructions in accordance with European or National Rules.
- Warning, prohibition and mandatory actions signs in accordance with European or National Rules.
- Information concerning the departure of train services.
- Identification of station facilities, where provided, and access routes to those facilities.

Information shall be provided at all points where passengers need to make a route taking decision and at intervals on the route at a maximum 100 m intervals. Signage, symbols and pictograms shall be applied consistently over the whole route.

The appropriate level of information required to make the decision shall be provided. For example, 'To the platforms' may be appropriate at the first decision making point when entering the station, rather than specific signs for individual platforms

Tactile information signage shall be fitted in:

- Toilets, for functional information and emergency call if appropriate
- Lifts in accordance with EN 81-70:2003 Appendix E.4.

Advertisements shall not be combined with the routeing and information systems.

Note: General information about public transport services shall not be considered as advertisements for the purposes of this Clause.

The following specific PRM graphic symbols and pictograms shall be fitted:

- A sign conforming to the international symbol for the 'provision for the disabled or handicapped persons' as described in Annex N Clauses N.2 and N.4
- Directional information for obstacle-free route and wheelchair accessible amenities
- Indication of the universal toilets
- If there is train configuration information on the platform, indication of the wheelchair boarding location.

The symbols are permitted to be combined with other symbols (for example: lift, toilet, etc).

Where inductive loops are fitted these shall be indicated by a sign as described Annex N Clauses N.2 and N.5.

Where the facility is provided, a graphic symbol shall indicate a storage place for heavy luggage and bulky goods.

If there is a call for assistance or call for information facility, these shall be indicated by a sign as described in Annex N Clauses N.2 and N.6.

If there is an Emergency call device:

- it shall have visual and tactile symbols,
- it shall be indicated by a sign as described in clause Annex N Clauses N.2 and N.7.

and shall have:

- A visual and audible indication that the device has been operated
- Additional operating information if necessary

In universal toilets and in wheelchair accessible toilets, where hinged handrails are provided, a graphic symbol showing the rail in both the upright and lowered position shall be provided.

There shall be no more than five pictograms, together with a directional arrow, indicating a single direction placed adjacent to each other at a single location.

4.1.2.11. Interoperability constituent requirements

Displays shall be sized to show complete individual station names or words of messages. Each station name, or words of messages, shall be displayed for a minimum of 2 seconds. If a scrolling display is used (either horizontal or vertical), each complete word shall be displayed for a minimum of 2 seconds and the horizontal scrolling speed shall not exceed 6 characters per second.

The minimum height of letters shall be calculated according to the following formula: Reading distance in mm divided by 250 = font size (for example: 10 000 mm/250 = 40 mm).

All safety, warning, mandatory action and prohibition signs shall include pictograms and shall be designed according to ISO 3864-1

Maximum reading distance is a characteristic of the interoperability constituent.

4.1.2.12. Spoken information

The spoken information shall have a minimum RASTI level of 0,5, in accordance with IEC 60268-16 part 16, in all areas.

Where provided, spoken information shall be consistent with essential visual information that is being displayed.

Where spoken information is not provided automatically, an audible communication system shall be provided to allow users to get information upon request.

4.1.2.13. Emergency exits, alarms

Emergency exits and alarms shall be in accordance with European or National Rules.

4.1.2.14. Geometry of footbridges and subways

If footbridges or subways are used as part of the normal passenger walking route within the confines of the station, these shall have an obstacle-free area of a minimum of 1 600 mm wide and a minimum headroom of 2 300 mm throughout. The minimum width requirement does not take into account additional width that may be required for high passenger flows, these additional widths shall be in accordance with National Rules.

4.1.2.15. Stairs

Staircases shall comply with European or National Rules.

Staircases on the main route shall have a minimum obstacle-free width of 1 600 mm measured between the handrails. The minimum width requirement does not take into account additional width that may be required for passenger flows.

All stair tread surfaces shall have anti-slip properties.

Prior to the first ascending stair and also prior to the first descending stair there shall be a tactile band, over the whole width of the stair. This band shall have a minimum depth of 400 mm, shall contrast with and be integrated into the floor surface. This band shall differ to those used for the tactile guide path where installed.

Open areas beneath stairs shall be protected to prevent passengers from inadvertent collision with structural supports and areas of reduced headroom.

4.1.2.16. Handrails

Stairs and ramps shall be provided with handrails on both sides and at two levels. The higher handrail shall be positioned at between 850 mm and 1 000 mm above floor level, the lower handrail shall be positioned at a height of between 500 mm and 750 mm above floor level.

There shall be a minimum clear space of 40 mm between the handrail and other parts of the structure other than its mountings.

Handrails shall be continuous. When fitted on stairs they shall extend for a minimum of 300 mm beyond the top and bottom steps (these extensions may be curved away in order to prevent obstructions).

The handrail shall be rounded and have a cross section of 30 mm to 50 mm equivalent diameter.

Handrails shall contrast with the surrounding wall colours.

4.1.2.17. Ramps, escalators, lifts, travelators

Ramps shall be installed for PRM unable to use stairs where lifts are not provided.

Ramps shall be in accordance with European or National Rules.

Where fitted, escalators shall have a maximum speed of 0,65 m/s and shall be designed in accordance with European or National Rules.

Lifts shall be provided where ramps are not available and shall be designed in accordance with EN 81-70:2003, clause 5.3.2.1 table 1.

Where fitted, travelators shall have a maximum speed of 0,75 m/s, a maximum slope of 12 degrees (21,3 %), and shall be designed in accordance with European or National Rules.

4.1.2.18. Platform height and offset

4.1.2.18.1 Platform height

For platforms on the Conventional Rail Network, two nominal values are permissible for platform height: 550 mm and 760 mm above the running surface. The tolerances on these dimensions shall be within -35 mm/+ 0 mm.

For platforms on the Conventional Rail Network where tramways (e.g. Stadtbahn or Tram-Train) are intended to stop, a nominal height of platform between 300 mm and 380 mm is permitted. The tolerances on these dimensions shall be within ± 20 mm.

Status: This is the original version (as it was originally adopted).

In curves with a radius of less than 500 m, it is permitted for the platform height to be greater or less than those specified provided that the first useable step of the vehicle complies with figure 11 in clause 4.2.2.12.1

4.1.2.18.2 Platform offset

Note to be removed from the CR PRM TSI at the end of the process: The High-Speed Infrastructure TSI sets out the requirements for platforms on the High-Speed Rail Network.

For platforms on the Conventional Rail Network, platform edges positioned at the nominal heights of 550 mm and 760 mm, shall meet the minimum structure gauge as defined in EN (open point, National Rules shall apply for the minimum structure gauge pending TSI revision after publication of EN15273-3:2006); and the conventional value b_{q0} from the track centre parallel to the running plane shall be obtained from the formula, which does not take into consideration effects of

- track gauge widening in curves,
- cant,
- switches and crossings,
- quasi-static inclination
- construction and maintenance tolerances

where:

$$b_{q0} = 1650 + \frac{3750}{R}$$

R is the radius of the curve of the track, in metres,

The calculated value b_{qlim} is specified in pr EN15273-3:2006 and takes into consideration all other values that are not included within the formula of b_{q0} . The actual value of b_q for the positioning of the platform edges from the track centre parallel to the running plane will allow for variation due to the tolerance T_q for the positioning of the platform edges or their maintenance: $b_{qlim} \leq b_q \leq b_{qlim} + T_q$.

The tolerance T_q shall be $0 \leq T_q \leq 50$ mm.

Effect of cant shall be compensated outside of the curve for the part exceeding 25 mm by a platform edge overhanging above the recess required to the quasi static inclination of the structure gauge perpendicularly to the running surface.

As a consequence, the actual gap may be greater than the conventional gap.

4.1.2.18.3 Track layout along the platforms

Note to be removed from the CR PRM TSI at the end of the process: Platforms on lines of Category I of the High-Speed Rail Network shall comply with the High-Speed Infrastructure TSI.

Note to be included in the High-Speed Infrastructure TSI: Platforms on lines of category II and III of the High-Speed Rail Network shall comply with the clause 4.1.2.18.3 of the CR PRM TSI.

For platforms on the Conventional Rail Network the track adjacent to the platforms shall preferably be straight, but shall nowhere have a radius of less than 300 m.

4.1.2.19. Platform width and edge of platform

It is permitted for the width of the platform to be variable on the whole length of the platform. The minimum width of the platform without obstacles shall be the greater of either:

— the width of the danger area plus the width of two opposing freeways of 800 mm (1 600 mm) or,

For a single side platform 2 500 mm, or for an island platform 3 300 mm (this dimension may taper to 2 500 mm at the platform ends).

The minimum width requirement does not take into account additional width that may be required for passenger flows.

It is permitted to have small obstacles of a length of less than 1 000 mm (for example:- masts, pylons, booths, seats) inside this freeway of 1 600 mm. The distance from the edge of the platform to the obstacle shall be a minimum of 1 600 mm and there shall be a minimum freeway of 800 mm from the edge of the obstacle to the danger area.

If the distance between any two small obstacles is less than 2 400 mm they shall be deemed to form one large obstacle.

The minimum distance from the edge of obstacles like walls, seating places, lifts and stairs that have a length of more than 1 000 mm but less than 10 000 mm, and the edge of the danger zone, shall be 1 200 mm. The distance between the edge of the platform and the edge of this obstacle shall be a minimum of 2 000 mm.

The minimum distance from the edges of obstacle like walls, seating places, travelators and stairs that have a length of more than 10 000 mm, and the edge of the danger zone, shall be 1 600 mm. The distance between the edge of the platform and the edge of this obstacle shall be a minimum of 2 400 mm.

If there are auxiliary facilities on-board trains, or on the platform, to allow wheelchair users to board on or alight from trains, a free space of 1 500 mm from the edge of the facility where the wheelchair boards, or lands, at the platform level, to the next obstacle on the platform, or to the opposite danger area, shall be provided where such facilities are likely to be used. A new station shall meet this requirement for all trains that are planned to stop at the platform.

The danger area of a platform commences at the rail side edge of the platform and is defined as the area where passengers may be subject to dangerous forces due to the slipstream effect of moving trains dependent upon their speed. For the conventional rail system, this danger area shall be in accordance with National Rules.

The boundary of the danger area, furthest from the rail side edge of the platform, shall be marked with visual and tactile warnings. The tactile marking shall be in accordance with National Rules.

The visual warning shall be a colour contrasting, slip resistant, warning line with a minimum width of 100 mm.

The colour of the material at the rail side edge of the platform shall contrast with the darkness of the gap. This material shall be slip resistant.

4.1.2.20. End of platform

The end of the platform shall have both visual and tactile markings.

4.1.2.21. Boarding aids for passengers using wheelchairs

4.1.2.21.1 Subsystem requirements

When a platform in a station that has obstacle free access routes in accordance with 4.1.2.3.1 is intended to receive trains stopping in normal operation with wheelchair-compatible doorway,

a boarding aid shall be provided to be used between that doorway and the platform to allow a passenger in a wheelchair to board or alight,

- unless it is demonstrated that the gap between the edge of the door sill of that doorway and the edge of the platform is not more than 75 mm measured horizontally and not more than 50 mm measured vertically;
- and
- unless there is a station stop within 30 km, on the same route, provided with boarding aids.

The responsible Infrastructure Manager (or Station Manager(s) if they are the responsible entities) and Railway Undertaking shall agree the management of the boarding aid in line with Regulation (EC) No 1371/2007 of the European Parliament and Council on Rail Passengers' Rights and Obligations⁽⁵⁾ in order to establish which party is responsible for provision of boarding aids. The Infrastructure Manager (or Station Manager(s)) and Railway Undertaking shall ensure that the division of responsibilities they agree is the most viable overall solution.

Such agreements shall define:

- the station platforms where a boarding aid has to be provided by the Infrastructure Manager or the Station Manager and the Rolling Stock for which it will be used,
- the station platforms where a boarding aid has to be provided by the Railway Undertaking and the Rolling Stock for which it will be used,
- the Rolling Stock where a boarding aid has to be provided by the Railway Undertaking and the station platform where it will be used,
- the specific rules for stopping the trains in order to comply with clause 4.1.2.19 (area for boarding aids for wheelchair users).

In its Safety Management System, the Railway Undertaking shall indicate what its obligations are according to such agreements, and how it intends to comply with them.

In its Safety Management System, the Infrastructure Manager shall indicate what its obligations are according to such agreements, and how it intends to comply with them.

In the paragraphs above, the Station Manager operating the platforms is considered as an Infrastructure Manager according to Directive 91/440/EC art 3: definition of Infrastructure and regulation 2598/70/EC.

If the result of the above is that all types of Rolling Stock stopping at the platform are equipped with boarding aids compatible with the platform, it is permissible for aids not to be provided at the platform.

The boarding aid shall fulfil the requirements of clause 4.1.2.21.2. If the wheelchair boarding position is pre-defined, the platform position(s) of the wheelchair accessible doorway(s) may be marked with the international symbol for the 'provision for the disabled or handicapped persons'. Such signs shall be in accordance with Annex N Clauses N.2 and N.4.

Ramps

An access ramp, whether manual or semi-automatic, to be operated by a member of staff, shall be made available whether stored on the station platform or on board.

The ramp shall fulfil the requirements of clause 4.1.2.21.2.

Platform lifts

If a platform lift is used, it shall comply with the requirements of clause 4.1.2.21.2.

4.1.2.21.2 Interoperability constituent requirements

If boarding aids are situated at stations, they shall accommodate a wheelchair with characteristics as detailed in Annex M:

The boarding aid shall withstand a weight of at least 300 kg, placed at the centre of the device distributed over an area of 660 mm by 660 mm.

If the boarding device is power operated the boarding aid shall incorporate an emergency method of manual operation should power fail.

Ramps

The ramp surface shall be slip resistant and shall have an effective clear width of a minimum of 760 mm.

Ramps shall have raised edges on both sides to prevent mobility aid wheels from slipping off.

The upstands at both ends of the ramp shall be bevelled and shall not be higher than 20 mm. They shall have contrasting hazard warning bands.

The ramp slope shall have a maximum slope of 10,2 degrees (18 %).

When in use for boarding or alighting, the ramp shall be secured in use so that it is not subject to displacement when loading or unloading.

A secure storage method shall be provided to ensure that ramps, including portable ramps, when stored do not cause an obstruction to passengers.

Platform lifts

Where a platform lift is used, it shall comply with the following:

The lift platform surface shall be slip resistant. At surface level, the lift platform shall have a minimum clear width of 720 mm.

The design of the lift shall ensure that the vehicle cannot be moved when the lift is not stowed.

Where provided, each control for deploying, lowering to ground level, raising and stowing the lift shall require continuous manual pressure by the operator and shall not allow an improper lift sequencing when the lift platform is occupied.

The lift shall incorporate an emergency method of deploying, lowering to ground level with a lift occupant, and raising and stowing the empty lift if the power to the lift fails.

No part of the lift platform shall move at a rate exceeding 150 mm/second during lowering and lifting an occupant, and shall not exceed 300 mm/second during deploying or stowing (except if the lift is manually deployed or stowed). The maximum lift platform horizontal and vertical acceleration when occupied shall be 0,3 g.

The lift platform shall be equipped with barriers to prevent any of the wheels of a wheelchair from rolling off the lift platform during its operation.

A movable barrier or inherent design feature shall prevent a wheelchair from rolling off the edge closest to the vehicle until the lift is in its fully raised position.

Each side of the lift platform which extends beyond the vehicle in its raised position shall have a barrier a minimum 25 mm high. Such barriers shall not interfere with manoeuvring into or out of the aisle.

The loading-edge barrier (outer barrier) which functions as a loading ramp when the lift is at ground level, shall be sufficient when raised or closed, or a supplementary system shall be provided, to prevent a power wheelchair from riding over or defeating it.

The lift shall permit both inboard and outboard facing of wheelchair.

A secure stowage system shall be provided to ensure that the stowed lift does not impinge on a passenger's wheelchair or mobility aid or pose any hazard to passengers

4.1.2.22. Level track crossing at stations

If level track crossings are permitted to be used by passengers according to the National Rules, and required to provide the obstacle-free route, they shall be accessible to all categories of PRM.

They shall be designed so that the smallest wheel of a wheelchair, as defined in Annex M, cannot be trapped within the crossing surface and the rail.

Visual and tactile markings shall be provided to identify the boundaries of the crossing surface.

4.1.3. Functional and technical specifications of the interfaces

Due to the fact that the Conventional Rail TSIs do not, currently, exist for passenger Rolling Stock and for Infrastructure, this section remains an open point.

There is no interface with the Control Command and Signalling subsystem.

The interfaces with the Operation subsystem are described in section 4.1.4 'Operating Rules'.

4.1.4. Operating rules

The following operating rules do not form any part of the assessment of Infrastructure.

This TSI does not specify operating rules for evacuation in the case of hazardous situations, only the relevant technical requirements. The purpose of the technical requirements for Infrastructure is to facilitate evacuation for all, including PRM.

In light of the essential requirements in section 3, the operating rules specific to the Infrastructure Subsystem according to the technical scope as defined in clause 1.1, concerned by this TSI, are as follows:

- *General*

The Infrastructure Manager or Station Manager shall have a written policy to ensure that all categories of PRM can access the passenger Infrastructure at all operational times in accordance with the technical requirements of this TSI. Furthermore, the policy shall be compatible with any Railway Undertaking's policy that may wish to use the facilities, (refer to Section 4.2.4) as appropriate. The policy shall be implemented through the provision of adequate information to staff, procedures and training. The Infrastructure policy shall include, but not be limited to, operating rules for the following situations:

- *Obstacle-free routes*

When a new, renewed or upgraded stations **that have a daily passenger flow of 1 000 passengers or less, combined embarking and disembarking, averaged over a 12 month period**, does not meet the requirements related to the lift and/or ramp aspects of the obstacle-free route requirements according to clause 4.1.2.3.1, National Rules shall be applied for organising the transport of wheelchair users by an accessible means between this non accessible station and the next accessible station on the same route.

- *Station Accessibility*

Operating rules shall be made to ensure that information regarding the level of accessibility of all stations is freely available.

— *Unstaffed Stations — Ticketing for Visually Impaired Passengers*

Operating rules shall be written and implemented with respect to unstaffed stations where vending machines are relied upon for ticketing (refer to Section 4.1.2.9). In such situations, an alternative means of ticketing, accessible to visually impaired passengers, shall always be available. (For example, permitting purchasing either on the train or at the destination)

— *Ticketing Control — Turnstiles*

In cases where turnstiles are utilised for ticketing control, operational rules shall be implemented, whereby PRM are offered parallel access through such control points. This PRM access shall permit wheelchair users, prams, bulky baggage, etc and may be controlled by staff or be automatic.

— *Visual and Spoken Information — Achieving Consistency*

Operating rules shall be implemented to ensure consistency between essential visual and spoken information (refer to Section 4.1.2.12). Staff making announcements shall follow standard procedures to achieve complete consistency of essential information.

— *On-demand Spoken Passenger Information System*

In situations where essential spoken information is not provided via a public address system at a station (refer to 4.1.2.12), operating rules shall be implemented to ensure the provision of an alternative information system, whereby passengers are able to acquire the same information audibly at the station (e.g. a staffed or automated telephone information service).

— *Platform — Wheelchair Boarding Aid Operational Zone*

The Railway Undertaking and the Infrastructure Manager or Station Manager shall define together the area on the platform where the facility is likely to be used and shall demonstrate its validity. This area shall be compatible with the existing platforms where the train is likely to stop.

A consequence of above is that the stopping point of the train shall in some cases be adjusted in order to comply with this requirement.

Operational rules shall be implemented to take account of train composition variations (refer to Section 4.1.2.19) such that the stopping point of trains can be determined with respect to the boarding aid operational zones.

A free space of 1 500 mm from the platform edge shall be provided on the platform for each boarding aid (refer to 4.1.2.19).

— *Safety of Manual and Powered Wheelchair Boarding Aids*

Operations rules shall be implemented concerning the operation of boarding aids by station staff (refer to Section 4.1.2.21.1 & 2).

An operational rule shall be implemented concerning the use by staff of the moveable safety barrier fitted to wheelchair lifts (refer to Section 4.1.2.21.2).

Operational rules shall be implemented to ensure that staff are able to safely operate boarding ramps, with respect to deployment, securing, raising, lowering and stowing (refer to Section 4.1.2.21.2).

— *Assistance to Wheelchair Users*

Operational rules shall be implemented to ensure that staff are aware that wheelchair users may require assistance to board and alight the train, and shall provide such assistance if required.

Wheelchair users may be required to book such assistance in advance in order to ensure that trained staff are available.

— *Supervised Level Track Crossing*

Where National Rules permit supervised level track crossings, operating rules shall be implemented to ensure that staff at supervised level track crossings give appropriate assistance to PRM, including indication of when it is safe to cross the track.

4.1.5. Maintenance rules

In light of the essential requirements in section 3, the maintenance rules specific to the Infrastructure Subsystem according to the technical scope as defined in clause 1.1) concerned by this TSI are as follows:

The Infrastructure Manager or Station Manager shall have procedures that include the provision of alternative assistance to PRM during maintenance, replacement or repair of facilities that are for PRM use.

4.1.6. Professional qualifications

The professional qualifications of staff required for the operation of the Infrastructure Subsystem according to the technical scope as defined in clause 1.1, and according to clause 4.1.4 giving the list of operational rules, concerned by this TSI, are as follows:

Professional training of staff performing the tasks of accompanying trains, delivering service and help for passengers at a station and of selling tickets shall include the subject of disability awareness and equality, including the specific needs of each category of PRM.

Professional training of engineers and managers, responsible for maintaining and operating the Infrastructure, shall include the subject of disability awareness and equality, including the specific needs of each category of PRM.

4.1.7. Health and safety conditions

There are neither specific requirements in the scope of this TSI related to the health and safety conditions of staff required for the operation of the Infrastructure Subsystem nor for the implementation of the TSI.

4.1.8. Infrastructure register

The requirements for the Infrastructure register with regard to this TSI are as follows:

- The geographical scope as defined in clause 1.2;
- Within the defined geographical scope, stations that are subject to this TSI shall be listed;
- For each station identified, the platforms at that station that fall within the scope of this TSI shall be listed.

For each station identified, and including all platforms that fall within the scope of this TSI, the following features shall be listed and described with respect to the relevant clauses in the TSI, as follows:

- Parking facilities in accordance with Clause 4.1.2.2;
- Obstacle-free route(s) in accordance with Clause 4.1.2.3;

- Tactile guidepaths where provided in accordance with Clause 4.1.2.3.2;
- Toilets, including those accessible to wheelchair users, in accordance with Clause 4.1.2.7;
- Ticketing, information desks and customer assistance points in accordance with Clause 4.1.2.9;
- Visual information systems in accordance with Clause 4.1.2.11;
- Ramps, escalators, lifts or travelators fitted in accordance with Clause 4.1.2.17;
- The height, offset, width and length of each platform in accordance with Clauses 4.1.2.18 and 4.1.2.19;
- Boarding aids and their description where provided in accordance with Clause 4.1.2.21;
- Level track crossings where these are available for use by PRM in accordance with Clause 4.1.2.22.

Where National Rules have been applied in order to establish conformance with this TSI, the relevant rules and clauses shall be stated against the relevant item in the register.

4.2. Subsystem Rolling Stock

4.2.1. Introduction

The trans-European conventional rail system, to which Directive 2001/16/EC modified by Directive 2004/50/EC applies and of which the subsystem is a part, is an integrated system whose consistency shall be verified. This consistency shall be checked in particular with regard to the specifications of each subsystem, its interfaces vis-à-vis the system in which it is integrated as well as the operating and maintenance rules.

The functional and technical specifications of the subsystem and its interfaces, described in sections 4.2.2, do not impose the use of specific technologies or technical solutions, except where this is strictly necessary for the interoperability of the trans-European conventional rail network. But innovative solutions for interoperability may require new specifications and/or new assessment methods. In order to allow technological innovation, these specifications and assessment methods shall be developed by the process described in sections 6.1.4 and 6.2.4.

Taking account of all the applicable essential requirements, the Rolling Stock subsystem is characterised by:

4.2.2. Functional and technical specifications

4.2.2.1. General

In light of the essential requirements in Section 3, the functional and technical specifications of the subsystem Rolling Stock related to Accessibility for Persons with Reduced Mobility are arranged as follows:

- Seats
- Wheelchair spaces
- Doors
- Lighting
- Toilets
- Clearways
- Customer information
- Height changes
- Handrails

- Wheelchair accessible sleeping accommodation
- Step position for vehicle access and egress

For each basic parameter a general clause introduces the following clauses.

These following clauses detail the conditions to be met in order to fulfil the requirements introduced in the general clause.

4.2.2.2. Seats

4.2.2.2.1. General

Handholds or vertical handrails or other items that can be used for personal stability, whilst using the aisle, shall be provided on seat backs of all aisle-side seats unless the seat touches the back of another seat facing in the opposite direction which is fitted with a handhold or touches a partition.

Handholds or other items that can be used for personal stability shall be positioned at a height of between 800 mm and 1 200 mm above the floor, shall not protrude into the clearway and shall contrast with the seat.

In seating areas with fixed longitudinal seats, handrails shall be used for personal stability. These handrails shall be at a maximum distance of 2 000 mm apart, shall be positioned at a height of between 800 mm and 1 200 mm above the floor and shall contrast with the vehicle interior surroundings.

The handholds or other items shall not have sharp edges.

4.2.2.2.2. Priority seats

4.2.2.2.2. General

Not less than 10 percent of the seats by fixed trainset or individual vehicle, and by class shall be designated as priority seats for the use of PRM.

The priority seats and vehicles containing them shall be identified by signs complying with Annex N Clauses N.3 and N.8 and shall state that other passengers should make such seats available to those who are eligible to use them.

The priority seats shall be located within the passenger saloon and in close proximity to external doors.

When seats are fitted with armrests, priority seats shall be fitted with movable armrests, this excludes armrests placed along the vehicle bodyside. The movable armrest shall move into a position in line with the seat back cushion to enable unrestricted access to the seat or to any adjacent priority seats.

Priority seats shall not be tip-up seats.

Each priority seat and the space available to its user shall comply with the diagrams shown in the figures 1 to 4.

The whole useful sitting surface of the priority seat shall be a minimum of 450 mm wide (see figure1).

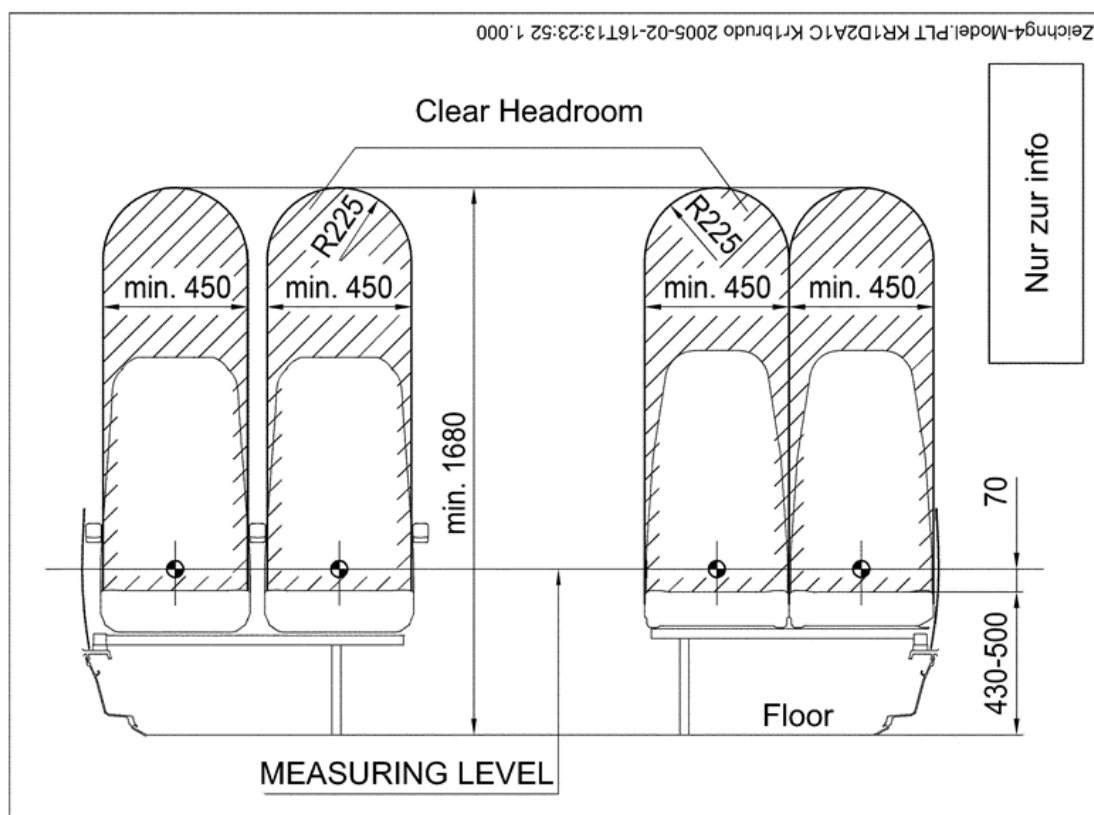

The top of each priority seat cushion shall be between 430 and 500 mm above floor level at the front edge of the seat. The clear headroom above each seat shall be at least 1 680 mm from floor level (see figure 2), except on double-decker trains on which luggage racks are provided above the seats. In such case a reduced headroom of 1 520 mm is permitted for priority seats underneath the luggage racks, provided that at least 50 % of priority seats maintain a headroom of 1 680 mm.

Note: In the following figures nos. 2 to 4 the cross sectional views shown are taken through the centre line of the seat.

Status: This is the original version (as it was originally adopted).

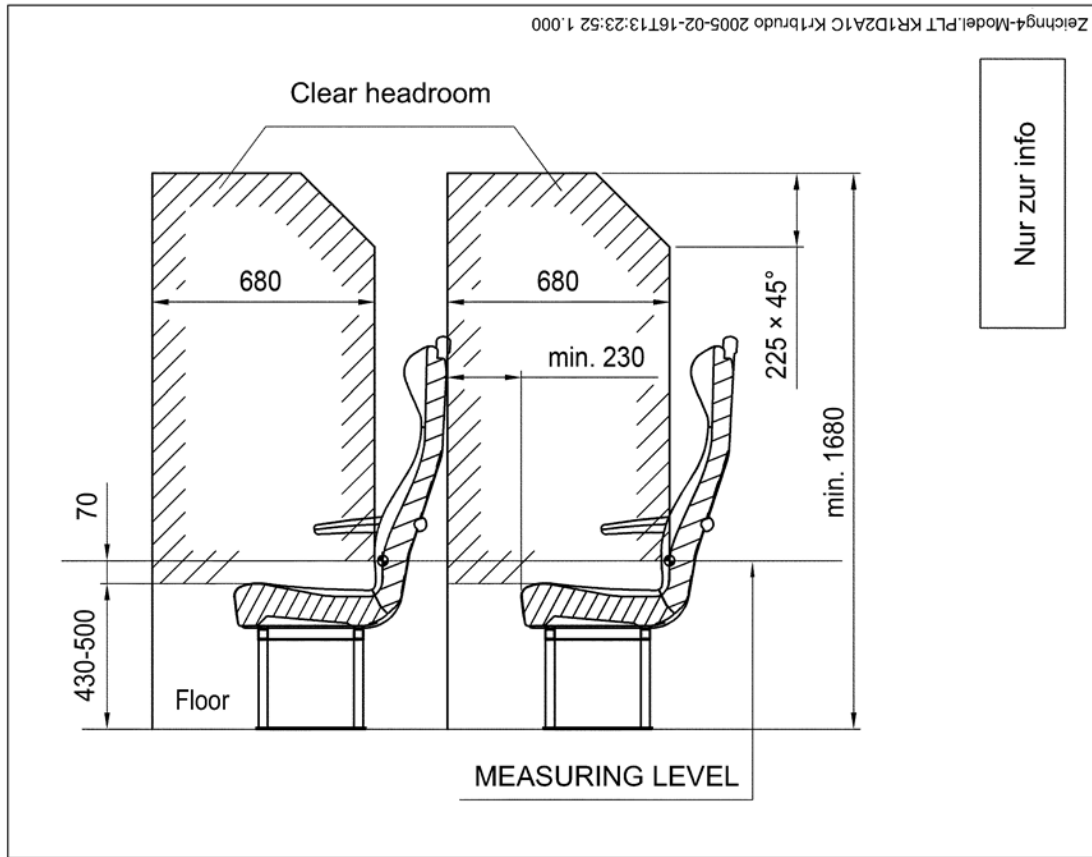

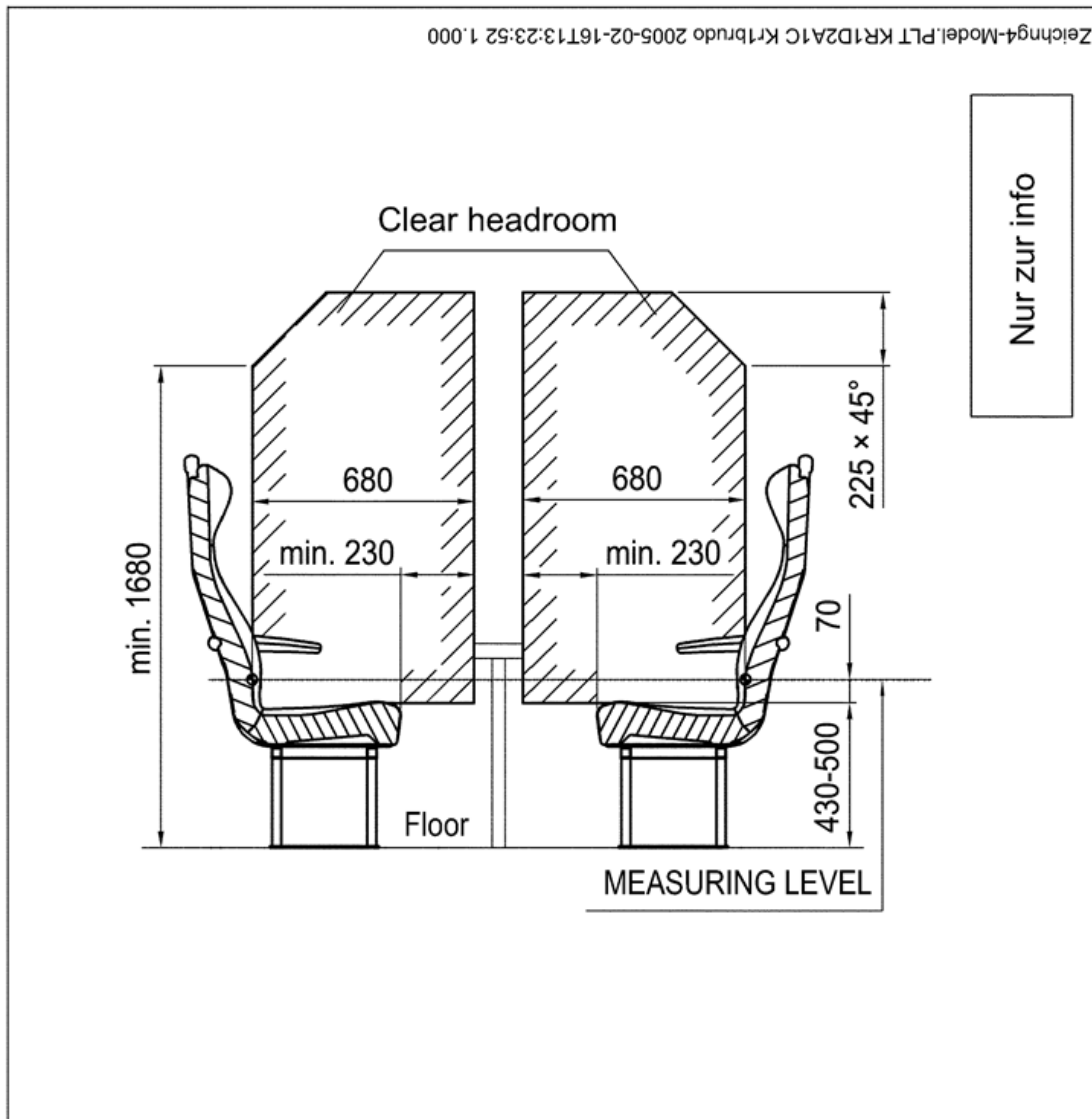

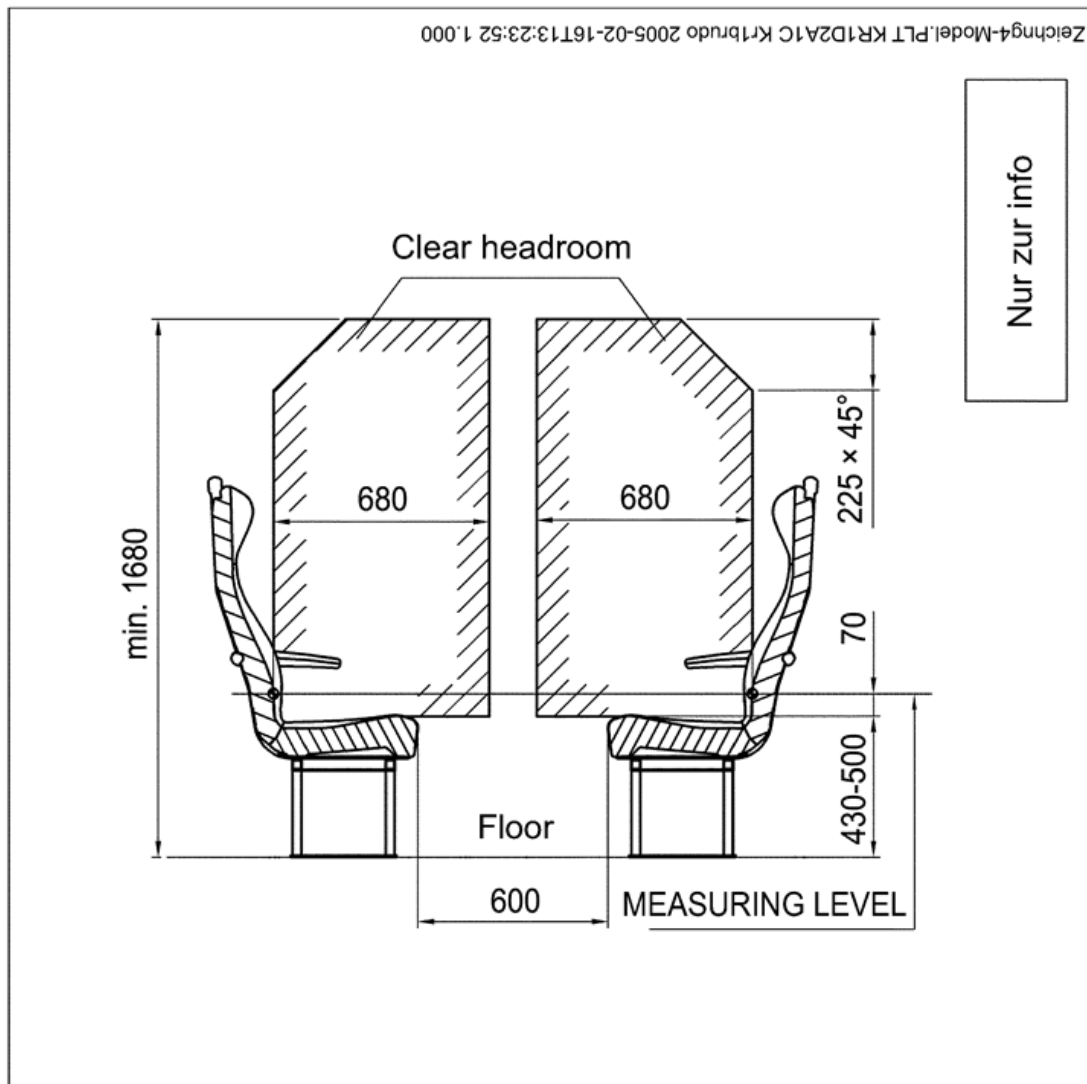

Where reclining seats are fitted, the dimensions shall be measured when the seats are in their fully upright position.

4.2.2.2.2. Uni-directional seats

Where uni-directional priority seats are provided, the clearance in front of each seat shall comply with figure 2.

As shown in figures 1 to 4, the distance between the front surface of the seat back and the vertical plane through the rearmost part of the seat in front shall be a minimum of 680 mm, noting that the required seat pitch shall be measured from the centre of the seat 70 mm above where the cushion meets the back support. There shall also be a clear space between the front edge of the seat cushion and the same vertical plane for the seat in front of a minimum of 230 mm.

4.2.2.2.2. Facing seats arrangement

Where facing priority seats are provided, the distance between the front edges of the seat cushions shall be a minimum of 600 mm (See figure 4).

Where facing priority seats are equipped with a table, there shall be a minimum clear horizontal distance between the front edge of the seat cushion and the leading edge of the table of at least 230 mm (See figure 3).

4.2.2.3. Wheelchair spaces

According to the length of the train, excluding the locomotive or power head, there shall be in that train not less than the number of wheelchair spaces shown in the following table:

Train length	Number of wheelchair spaces by train
Less than 205 metres	2 wheelchair spaces
205 to 300 metres	3 wheelchair spaces
More than 300 metres	4 wheelchair spaces

To ensure stability, the wheelchair space shall be designed for the wheelchair to be positioned either facing or back to the direction of travel.

The wheelchair space, for one wheelchair user, shall accommodate a wheelchair with the following characteristics:

If boarding aids are situated at stations, they shall accommodate a wheelchair with characteristics as detailed in Annex M:

There shall be no obstruction of the designated space between the floor and the ceiling of the vehicle other than an overhead luggage rack, a horizontal handrail attached to the wall or ceiling of the vehicle or a table in accordance with the requirements of clause 4.2.2.10.

The minimum distance in the longitudinal plane between the wheelchair space and a front surface 2 shall be in accordance with figure 5. Surface 1 may be a closed tip-up or foldable seat, or a partition.

Status: This is the original version (as it was originally adopted).

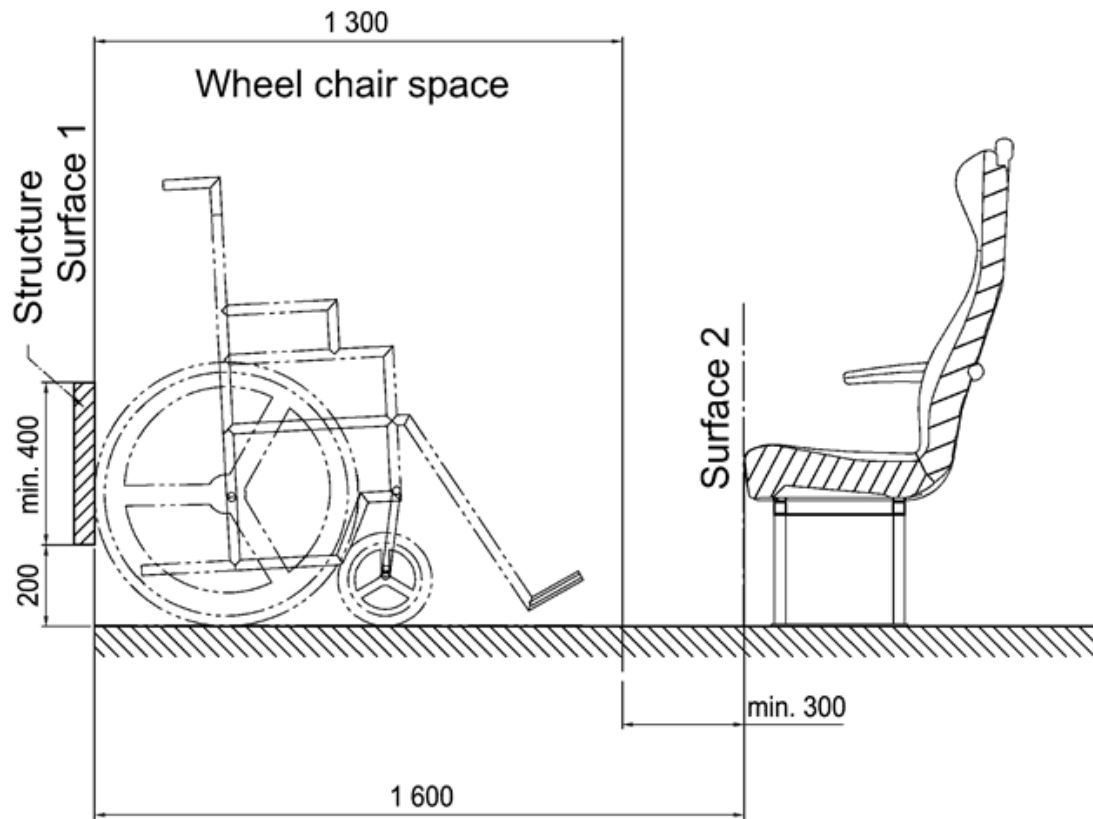

If surface 2 is the front edge of a passenger seat cushion in a facing arrangement and if this seat can be occupied by a passenger, the minimum distance shall be not less than 300 mm.

If surface 2 is a passenger seat back in a uni-directional arrangement, or a partition or a closed tip-up or foldable seat in front of wheelchair space, the minimum distance shall be not less than 200 mm.

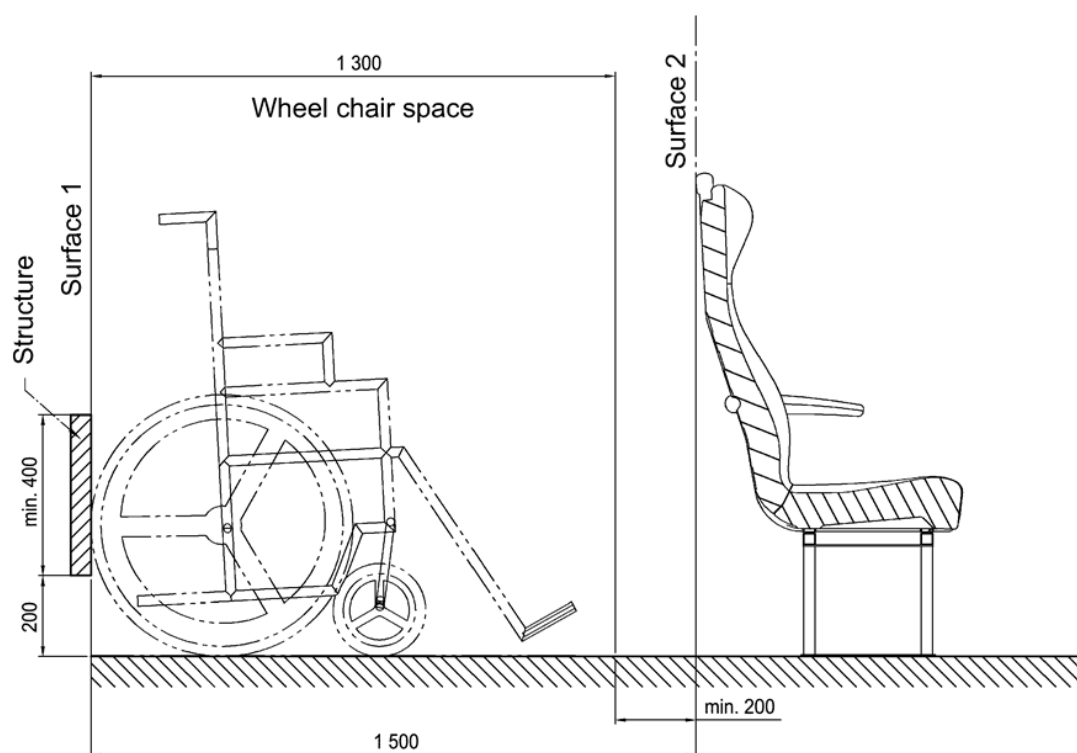

Tip-up or folding seats may be installed in the wheelchair space but, when in the stowed position, shall not encroach on the dimensional requirements of the wheelchair space.

There shall be a structure or other acceptable fitting 700 mm wide (as shown in figure 6) at one end of the wheelchair space. The height of the structure, or fitting, shall be capable of preventing a wheelchair that has been positioned with its back against the structure or fitting, from tipping over backwards.

At least one seat shall be available either adjacent to or facing to the wheelchair spaces for a companion to travel with the wheelchair user. This seat shall offer the same level of comfort as other seats, and may also be situated on the opposing side of the clearway.

The wheelchair space shall be fitted with an alarm device that shall, in the event of danger, enable a wheelchair user to inform a person who can take appropriate action. It shall be placed within reach of a person seated in a reference wheelchair.

When the alarm device has been activated a visual and audible indication that the alarm system is working shall be provided.

The alarm device shall not be placed within a narrow recess or any other form of shielding which prevents immediate palm operation.

The positioning of the alarm device shall be within the comfortable reach of the person using the wheelchair rather than at the maximum limits.

Status: This is the original version (as it was originally adopted).

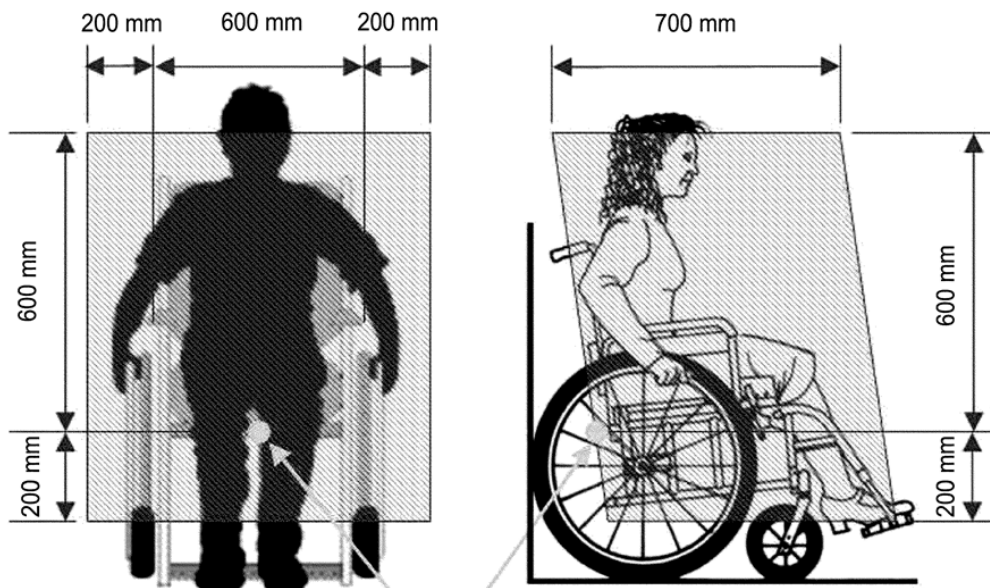

Seat Reference Point

(480 mm +/- 20 mm above floor and 350 mm +/- 20 mm forward of the structure)

A sign conforming to Annex N Clauses N.3 and N.4 shall be placed immediately next to, or in, the wheelchair space so as to identify the space as the wheelchair space.

4.2.2.4. Doors

4.2.2.4.1. General

To latch or unlatch a manually operated door, for use by the public, the control device shall be operable by the palm of the hand exerting a force not exceeding 20 Newtons.

Door controls, whether manual or pushbuttons, shall contrast with the surface on which they are mounted.

If pushbuttons or other remote control devices are provided for operation of doors then each pushbutton or device shall be operable by a force not greater than 15 Newtons.

If both open and closed pushbuttons are fitted one above the other, the top button shall always be the open control.

4.2.2.4.2. Exterior doors

4.2.2.4.2. Sub-system requirements

External passenger access, automatic and semi-automatic, doors shall incorporate devices that detect if they close on a passenger where a passenger is detected the doors shall automatically stop and remain free for a limited period of time.

All exterior passenger doorways shall have a minimum clear useable width of 800 mm when open.

External doors shall be painted or marked on the outside in a way that gives a contrast to the rest of the vehicle body-side.

The designated wheelchair exterior accessible doorways shall be the closest doorways to the designated wheelchair spaces.

The door to be used for wheelchair access shall be clearly labelled with a sign in accordance with Annex N Clauses N.3 and N.4.

From the inside of the vehicle the position of external doorways shall clearly be marked by use of contrast on the flooring adjacent to the doorway, as compared with the rest of the flooring of the vehicle.

When a door is enabled for opening a signal shall be given that is clearly audible to persons inside and outside the train. This alert signal shall sound for a minimum of five seconds unless the door is operated, in which case it may cease after 3 seconds. This requirement is not applicable for external audible signals on high speed Class 1 and Class 2 trains.

When a door is automatically or remotely opened by the driver or other member of the traincrew, the alert signal shall sound for a minimum 3 seconds from the moment that the door starts to open.

When a door that is automatically or remotely closed, is about to operate, an audible alarm shall be given to persons inside and outside the train. The alarm shall sound for a minimum of 2 seconds before the door starts to close and shall be different in tone to that used when the door is released. The alarm shall continue to sound while the door is closing.

The sound source for door warnings shall be located in the area local to the control device or, if there is no such control device, adjacent to the doorway

Passenger door audible warnings — Door enabled for opening

- Characteristic
 - A continuous or slow pulse multi tone (up to 2 pulses per second) of 2 combined tones
- Frequencies
 - 3 000 Hz \pm 500 Hz
 - and:
 - 1 750 Hz \pm 500 Hz
- Sound Pressure level
 - 70 dB $L_{Aeq, T} \pm 2$ measured on the centre point of the vestibule at a height of 1,5 m above the floor level. (T = total duration of the sound event)

Passenger door audible warnings — Door close warning

- Characteristic
 - A fast pulsed tone (6-10 pulses per second)
- Frequency
 - 1 900 Hz \pm 500 Hz
- Sound Pressure level
 - 70 dB $L_{Aeq, T} \pm 2$ measured outside the vehicle, 1,5 m away from the bodyside door centerline at 1,5 m above the platform level. Internal measurement as open alarm. (T = total duration of the sound event)

The method of door activation shall be by traincrew or semi-automatic (i.e. passenger pushbutton operation).

The door control shall be located either next to or on the door leaf.

The centre of exterior door controls, operable from the platform, shall be not less than 800 mm and not more than 1 200 mm measured vertically above platforms, for all platforms at which the train will stop. The centre of internal door controls for the exterior door shall be not less than 800 mm and not more than 1 200 mm measured vertically above the vehicle floor level.

4.2.2.4.2. Interoperability constituent requirements

If pushbuttons are provided for operation of doors then each pushbutton shall have visual indication, on or around the push button, when enabled and shall be operable by a force not greater than 15 Newtons. If the door closure is remotely activated by traincrew, the visual indication shall cease not less than 2 seconds before the door starts to close.

Such pushbuttons shall be identifiable by touch (for example:- tactile markings) and shall indicate the functionality.

4.2.2.4.3. Interior doors

4.2.2.4.3. Sub-system requirements

Internal automatic and semi-automatic doors shall incorporate devices that prevent passengers becoming trapped during operation of the doors.

If interior doors are fitted they shall comply with the requirements of this clause.

Door openings that are made available for wheelchair users shall have a minimum clear useable width of 800 mm.

To latch or unlatch a manually operated door, for use by the public, the control device shall be operable by the palm of the hand exerting a force not exceeding 20 Newtons.

The force required to open or close a manual door shall not exceed 60 Newtons.

The centre of interior door controls shall be not less than 800 mm and not more than 1 200 mm measured vertically above the vehicle floor level.

Automatic inter-vehicle and consecutive connecting doors shall operate either synchronously as a pair, or the second door shall automatically detect the person moving towards it and open.

If more than 75 % of a door's surface is made of a transparent material, it shall be marked with a minimum of two prominent bands made of signs, logos, emblems or decorative features. They shall be at a height between 1 500 mm and 2 000 mm for the upper band, and between 850 mm and 1 000 mm for the lower band, contrasting with the background over the entire width of the door. These bands shall be a minimum of 100 mm high.

4.2.2.4.3. Interoperability constituent requirements

If pushbuttons are provided for operation of doors then each pushbutton shall be illuminated (or the surround shall be illuminated) when enabled and shall be operable by a force not greater than 15 Newtons.

The centre of the control shall be not less than 800 mm and not more than 1 200 mm vertically above floor level.

Such controls shall be identifiable by touch (for example:- tactile markings) and shall indicate the functionality.

4.2.2.5. Lighting

Vehicle access steps shall be illuminated to a minimum of 75 Lux, measured across 80 % of the width of the step by a light placed within or immediately adjacent to it.

4.2.2.6. Toilets

4.2.2.6.1. General

When toilets are fitted in a train access to a universal toilet shall be provided from the wheelchair space and comply with the requirements of both the standard and universal toilets.

4.2.2.6.2. Standard toilet (Interoperability constituent requirements)

A standard toilet is not designed to be accessible to a wheelchair user.

The minimum door useable width shall be 500 mm

The centre of any door handle, lock or door control device on the exterior or interior of the toilet compartment shall be located at a minimum of 800 mm and a maximum of 1 200 mm above the floor.

A visual and tactile (or audible) indication shall be given to indicate when a door has been locked.

Any door control device, and other equipment inside the toilet compartment (except for baby change facilities) shall be operable by exerting a force not exceeding 20 Newtons.

Any control device, including flushing system, shall be provided in a contrasting colour and/or tone to the background surface, and shall be identifiable by touch.

Clear, precise information for the operation of any control device shall be provided, making use of pictograms and shall be tactile.

A fixed vertical and/or horizontal handrail shall be provided adjacent to the toilet pan and the wash basin.

Handrails shall be round in section with an outside diameter of 30 mm to 40 mm, and shall have a minimum clear distance of 45 mm to any adjacent surface. If a handrail is curved, the radius to the inside face of the curve shall be a minimum of 50 mm.

The toilet seat and lid, and any handrails shall be in a contrasting colour and/or tone to the background.

4.2.2.6.3. Universal toilet

A universal toilet is a toilet designed to be used by all passengers including all categories of PRM.

4.2.2.6.3. Interoperability constituent requirements (Universal toilet)

The toilet access door shall provide a minimum clear useable width of 800 mm.

The exterior of the door shall be marked with a sign in accordance with Annex N Clauses N.3 and N.4.

The centre of any door handle, lock or door control device on the exterior or interior of the toilet compartment shall be located at a minimum of 800 mm and a maximum of 1 200 mm above the floor.

A visual and tactile (or audible) indication shall be given to indicate when a door has been locked.

Any door control device, and other equipment inside the toilet compartment (except for baby change facilities) shall be operable by exerting a force not exceeding 20 Newtons.

There shall be sufficient space inside the toilet compartment to enable a wheelchair as defined in Annex M to be manoeuvred to a position adjacent to the toilet seat, see figure 8a.

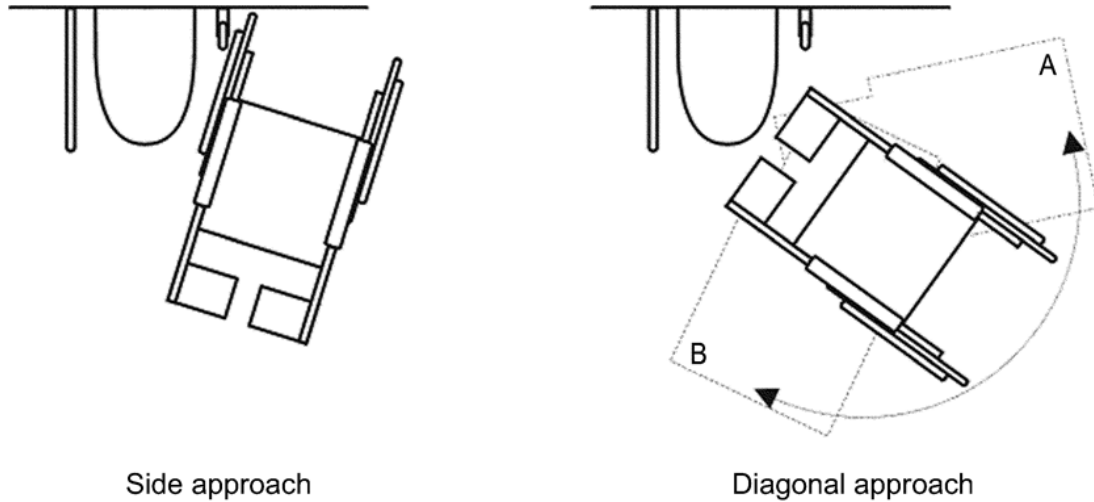

In front of the toilet seat there shall be a minimum clear space of 700 mm as shown in figure 8b.

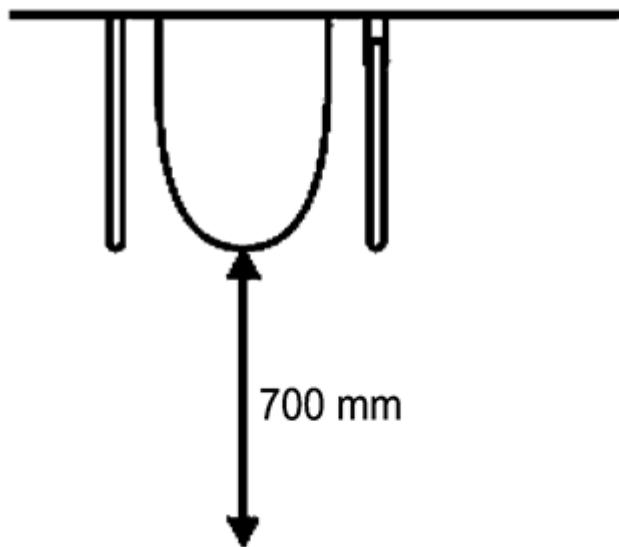

A horizontal handrail that complies with the dimensional requirements in the clause above shall be provided at each side of the toilet seat. The handrail on the wheelchair accessible side shall be hinged in such a way so as to enable an unobstructed transfer for the wheelchair user to and from the toilet seat, see figures 9 and 10.

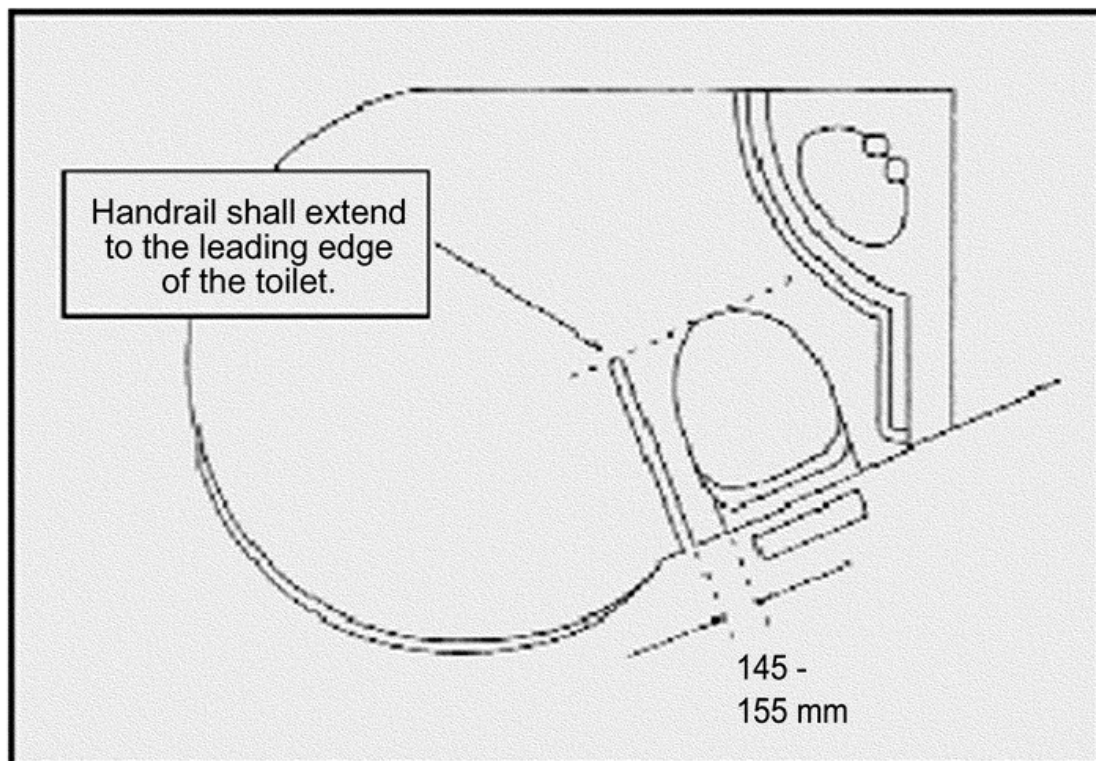

Status: This is the original version (as it was originally adopted).

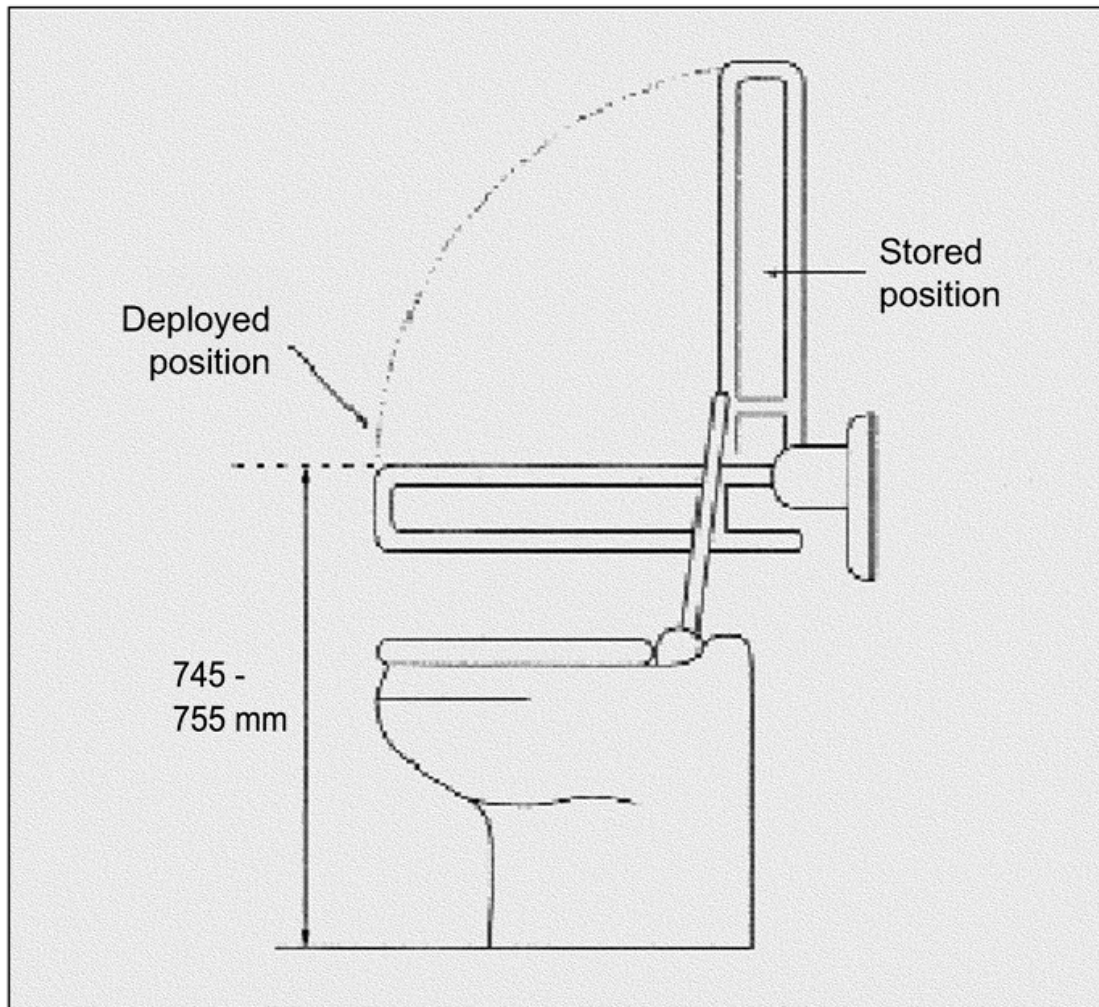

The surface of the toilet seat, when lowered shall be at a height of 450 mm to 500 mm above the floor level.

All amenities (wash basin, soap dispenser, mirror, water dispenser and hand dryer) shall be readily accessible to a person in a wheelchair.

The toilet cubicle shall be fitted with not less than two alarm devices that shall, in the event of danger enable, a PRM to inform a person who can take appropriate action. One shall be placed not more than 450 mm above the floor, measured vertically from the surface of the floor to the top of the control. The other shall be not less than 800 mm and not more than 1 200 mm above the floor measured, vertically to the top of the control.

The lower alarm device shall be positioned so that the control can be reached by a person lying on the floor. These two devices shall be located on different vertical surfaces of the cubicle so that they can be reached from a range of positions.

The alarm control shall be distinct from any other control within the toilet and be coloured differently from other control devices.

A sign in accordance with Annex N Clauses N.3 and N.7 shall be placed immediately next to each alarm device. The sign shall describe the function and required actions and shall contrast with the background and give clear visual and tactile information.

A visual and audible indication that the alarm system has been operated shall be provided within the toilet.

4.2.2.6.3. Interoperability constituent requirements (baby change)

If separate nursery facilities are not provided a facility to enable the changing of babies' nappies shall be incorporated within the universal toilet. In the lowered position, the changing facility shall be between 800 mm and 1 000 mm above floor level. It shall be a minimum of 500 mm wide and 700 mm long.

It shall be designed to prevent a baby from inadvertently sliding off, shall have no sharp edges and shall be able to take a minimum weight of 80 Kg.

If the baby-change table protrudes into the accessible toilet space, it shall be possible to put it into the stowed position using a force not exceeding 25 Newtons.

4.2.2.7. Clearways

From the vehicle entrance the minimum clearway width through the vehicle shall be 450 mm from floor level to a height of 1 000 mm and 550 mm from a height of 1 000 mm to 1 950 mm.

The clearway width between connecting vehicles of a single trainset shall maintain a minimum of 550 mm measured on straight and level track.

Access to and from wheelchair spaces, wheelchair accessible areas and wheelchair accessible doors shall have a minimum clearway width of 800 mm wide up to a minimum height of 1 450 mm at any point. The clearway shall be arranged to permit unobstructed movement of the reference wheelchair as detailed in Annex M.

A turning space, with a minimum diameter of 1 500 mm, shall be provided adjacent to the wheelchair space for the disabled person in the reference wheelchair to turn the wheelchair around. The wheelchair space may be part of the turning circle.

4.2.2.8. Customer Information

4.2.2.8.1. General

All information shall be of a consistent nature and in accordance with European or National Rules.

All information shall be coherent with the general routeing and information system especially colour and contrast in trains, platforms and entrances.

Visual information shall be legible in all lighting conditions when the vehicle or station is operational.

Visual information shall contrast with its background.

Descenders in Roman script shall be clearly recognisable and have a minimum size ratio of 20 % to the upper case characters.

Compressed descenders and ascenders shall not be used.

It shall be possible to give information (both audible and visual) in more than one language. (The choice and number of languages shall be the responsibility of the Railway Undertaking having regard to the clientele of an individual train service.)

The following information shall be provided:

Status: This is the original version (as it was originally adopted).

- Safety Information and Safety Instructions in accordance with European or National Rules
- Audible safety instructions in case of emergency
- Warning, prohibition and mandatory actions signs in accordance with European or National Rules.
- Information concerning the route of the train
- Information concerning the location of on-board facilities

4.2.2.8.2. Information (signage, pictograms inductive loops and emergency call devices)

4.2.2.8.2. Sub-system requirements

All safety, warning, mandatory action and prohibition signs shall include pictograms and shall be designed according to ISO 3864-1.

There shall be no more than five pictograms, together with a directional arrow, indicating a single direction placed adjacent to each other at a single location.

Tactile information signage shall be fitted in:

- Toilets, for functional information and emergency call if appropriate
- Trains, for door open/close button and emergency call

Advertisements shall not be combined with the routeing and information systems.

The following specific PRM graphic symbols and pictograms shall be fitted:

- Wheelchair symbol in accordance with Annex N Clauses N.3 and N.4
- Directional information for wheelchair accessible amenities
- Indication of the wheelchair accessible door location outside the train
- Indication of the wheelchair space inside the train
- Indication of the universal toilets

The symbols in can be combined with other symbols (for example: lift, toilet, etc).

4.2.2.8.2. Interoperable constituent requirements

Where inductive loops are fitted these shall be indicated by a sign complying with Annex N Clauses N.3 and N.5.

Where the facility is provided, a graphic symbol shall indicate a storage place for heavy luggage and bulky goods.

If there is a call for assistance or call for information facility, this shall be indicated by a sign complying with Annex N Clauses N.3 and N.6.

and shall have:

- A visual and audible indication that the device has been operated;
- Additional operating information if necessary

If there is an Emergency call device it shall comply with Annex N Clauses N.3 and N.7. And shall have:

- visual and tactile symbols,
- A visual and audible indication that the device has been operated
- Additional operating information if necessary.

In universal toilets and in wheelchair accessible toilets, where hinged handrails are provided, a graphic symbol showing the rail in both the upright and lowered position shall be provided.

4.2.2.8.3. Information (route description and seat reservation)

The final destination or route shall be displayed outside of the train on the platform side adjacent to at least one of the passenger access doors on a minimum of alternate vehicles of the train.

Where trains operate in a system, in which dynamic visual information is given on the station platforms within a distance of 50 meters, and destination or route information is also provided on the front of the train, it is not mandatory to provide information on the sides of each vehicle.

The final destination or route of the train shall be displayed inside each vehicle.

The next stop of the train shall be displayed such that it can be read from a minimum of 51 % of passenger seats inside each vehicle. This information shall be displayed at least two minutes before arrival at the station concerned. If the next station is less than two minutes planned journey time away, the next station shall be displayed immediately following departure from the previous station.

The requirement to make the destination and 'next stop' displays visible to 51 % from passenger seats need not be met if the train is partly or wholly divided into compartments of not more than 8 seats, which are serviced by a corridor. However, a display shall be visible to a person standing in a corridor outside a compartment and shall be visible to a passenger occupying a wheelchair space.

Details of the Route or Network on which the train operates shall be available (the Railway Undertaking shall decide the manner in which this information is provided).

The information about the next stop may be shown on the same display as the final destination. However, it shall revert to show the final destination as soon as the train has stopped.

The system shall be capable of giving announcements in more than one language. (The choice and number of languages shall be the responsibility of the Railway Undertaking having regard to the clientele of an individual train service).

If the system is automated, it shall be possible to suppress, or correct, incorrect or misleading information.

If the vehicle provides reserved seats then the number or letter of the vehicle (as used in the reservation system) shall be displayed on or adjacent to every door in characters not less than 70 mm high.

If seats are identified by numbers or letters, the number or letter of the seat shall be displayed on or adjacent to every seat in characters not less than 12 mm high. Such numbers and letters shall contrast with their background.

The train shall be fitted with a public address system which shall be used either for routine or emergency announcements by the driver or by another crewmember who has specific responsibility for passengers.

The system may operate on a manual, an automated or pre-programmed basis. If the system is automated, it shall be possible to suppress, or correct, incorrect or misleading information.

The system shall be used to announce the destination and next stop of the train, or on departure from, each stop.

Status: This is the original version (as it was originally adopted).

The system shall be used to announce the next stop of the train at least two minutes before the arrival of the train at that stop. If the next station is less than two minutes planned journey time away, the next station shall be announced immediately following departure from the previous station.

The spoken information shall have a minimum RASTI level of 0,5, in accordance with IEC 60268-16 part 16, in all areas. The system shall meet the requirement at each seat location and wheelchair space.

The system shall be capable of giving announcements in more than one language. (The choice and number of languages shall be the responsibility of the Railway Undertaking having regard to the clientele of an individual train service).

If the system is automated, it shall be possible to suppress, or correct, incorrect or misleading information.

4.2.2.8.4. Information (Interoperability constituent requirements)

Each station name (which may be abbreviated), or words of messages, shall be displayed for a minimum of 2 seconds. If a scrolling display is used (either horizontal or vertical), each complete word shall be displayed for a minimum of 2 seconds and the horizontal scrolling speed shall not exceed 6 characters per second. Sans Serif fonts, in mixed case, shall be used for all written information. (i.e. not in capital letters only).

Upper Case Letters and numbers used in front external displays shall have a minimum height of 70 mm and on side displays 35 mm on bodyside and internal indicators.

Inside trains the font size shall be not less than 35 mm for a reading distance in excess of 5 000 mm.

35 mm display characters shall be considered to be legible up to a maximum viewing distance of 10 000 mm.

4.2.2.9. Height changes

Internal steps (other than those for external access) shall have a maximum height of 200 mm and a minimum depth of 280 mm, measured at the central axis of the stairs. The first and the last step shall be indicated by a contrasting band with a depth of 45 mm to 50 mm extending the full width of the steps on both the front and the top surfaces of the step nosing. For double deck trains it is permitted to reduce this value to 270 mm for the stairs accessing the upper deck.

No steps are allowed between the vestibule of a wheelchair accessible exterior door, the wheelchair space, a universal sleeping compartment and the universal toilet except for a door threshold strip that shall not exceed 15 mm in height.

For ramps in the train the maximum slope shall not exceed the following values:

Length of ramp	Maximum gradient (degrees)	Maximum gradient (%)
> 1 000 mm	4,47	8
600 mm to 1 000 mm	8,5	15
Less than 600 mm	10,2	18

Note: These gradients shall be measured when the vehicle is stationary on straight and level track.

4.2.2.10. Handrails

All handrails fitted to a vehicle shall be round in section with an outside diameter of 30 mm to 40 mm, and shall have a minimum clear distance of 45 mm to any adjacent surface. If a handrail is curved, the radius to the inside face of the curve shall be a minimum of 50 mm.

All handrails shall contrast with their background.

Doorways with more than two entrance steps shall be provided with handrails on both sides of the doorway, fitted internally as close as practicable to the vehicle outer wall. They shall reach to a height of between 800 mm and 900 mm above the first useable step when boarding the train, according to the platform heights for which the Rolling Stock is designed to be used, and shall be parallel with the line of the step nosing.

A vertical handrail shall also be provided for stepping on and off the train. Doorways with up to two entrance steps shall be provided with vertical handrails on both sides of the doorway, fitted internally as close as practicable to the vehicle outer wall. They shall extend from 700 mm to 1 200 mm above the threshold of the first step.

Where the clearway of the gangway is less than 1 000 mm and longer than 2 000 mm there shall be handrails or handholds provided in, or adjacent to, inter-vehicle gangways that are provided for passenger use. Where the clearway of the gangway is wider than or equal to 1 000 mm handrails or handholds shall be provided in the gangway.

4.2.2.11. Wheelchair Accessible sleeping accommodation

When a train is equipped with sleeping accommodation for passengers it shall provide a vehicle containing not less than one wheelchair accessible sleeping accommodation that shall accommodate a wheelchair with the specification as defined in Annex M.

If there is more than one vehicle with sleeping accommodation for passengers in a train, there shall be not less than two wheelchair accessible sleeping compartments in the train.

If a rail vehicle provides wheelchair accessible sleeping accommodation the exterior of the relevant vehicle door shall be marked with a sign in accordance with Annex N Clauses N.3 and N.4.

The sleeping accommodation shall be fitted with not less than two alarm devices that shall, in the event of danger enable, a PRM to inform a person who can take appropriate action. One shall be placed not more than 450 millimetres above the floor, measured vertically from the surface of the floor to the top of the control. The other shall be not less than 600 millimetres and not more than 800 millimetres above the floor measured vertically to the top of the control.

The lower alarm device shall be positioned so that the control can be reached comfortably by a person lying on the floor. These two devices shall be located on different vertical surfaces of the sleeping accommodation. The alarm devices shall be distinct from any other control within the sleeping accommodation and be coloured differently from other control devices.

A sign conforming to Annex N Clauses N.3 and N.7 shall be placed immediately next to each alarm device. The sign shall describe the function and required actions and shall contrast with its background and have clear visual and tactile information.

A visual and audible indication that the alarm device has been operated shall be provided within the sleeping accommodation.

4.2.2.12. Step position for vehicle access and egress

4.2.2.12.1 General requirements

It shall be demonstrated that the point situated in the central position on the nose of the step⁽⁶⁾ of each access door on both sides of a vehicle standing centrally on the rails and in service condition with new wheels but without passengers, shall be located inside the surface identified as 'step location' on the figure 11 below, meeting the requirements explained below.

Access steps of the vehicle shall be designed to meet the following requirements according to the type of platform where the Rolling Stock is intended to stop, in normal operation. The end of the floor at the access door shall be considered as a step.

Steps shall be such that the maximum construction gauge of the vehicle meets the requirements of Annex C of the Freight Wagon TSI.

Requirement a) for all Rolling Stock intended to stop, in normal operation, at platforms below 550 mm height:

The lowest step (first level) shall be located at the lowest limit of the vehicle construction gauge, according to the requirements of Annex C of the Freight Wagon TSI valid for this vehicle.

The horizontal position of the lowest step (first level) shall be located at the outer limit of the vehicle construction gauge, according to the requirements of Annex C of the Freight Wagon TSI valid for this vehicle.

Requirement b) for all Rolling Stock intended to stop, in normal operation, at platforms of 550 mm height:

A step shall comply with the requirements of figure 11 and the following values when the vehicle stopped at its nominal position,

	δ_h mm	δ_{v+} mm	δ_{v-} mm
on a straight level track	200	230	160
on a track with a curve radius of 300 m	290	230	160

Requirement c) for all Rolling Stock intended to stop, in normal operation, at platforms of 760 mm height:

A step shall comply with the requirements of figure 11 and the following values when the vehicle stopped at its nominal position,

	δ_h mm	δ_{v+} mm	δ_{v-} mm
on a straight level track	200	230	160
on a track with a curve radius of 300 m	290	230	160

Requirement d) for all Rolling Stock intended to stop, in normal operation, at both platforms of 7600 mm height and platforms of 550 mm height or lower, and having two or more access steps:

In addition to the relevant requirements above, a step shall comply with the requirements of figure 11 and the following values when the vehicle is stopped at its nominal position, based upon a nominal platform height of 760 mm.

	δ_h mm	δ_{v+} mm	δ_{v-} mm
on a straight level track	380	230	160
on a track with a curve radius of 300 m	470	230	160

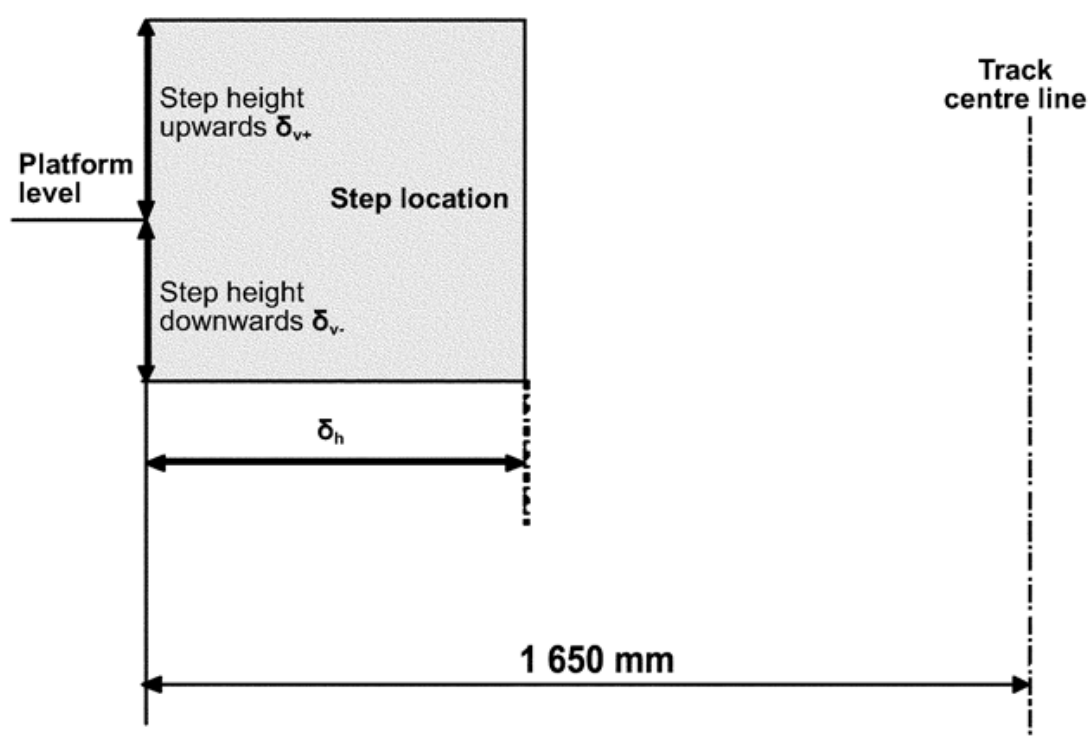

4.2.2.12.2 Access/egress steps

All steps for access and egress shall be slip resistant and shall have an effective clear width as large as the doorway width.

Internal steps for external access shall have a maximum height of 200 mm and a minimum depth of 240 mm (going) between the vertical edges of the step. The rising height of each step shall be equal. The first and the last step shall be indicated by a contrasting band with a depth of 45 mm to 50 mm extending the full width of the steps on both the front and the top surfaces of the step nosing.

The height of each step may be increased to a maximum of 230 mm if it can be demonstrated that this achieves a reduction of one in the total number of steps required. (For example, if a vertical distance of 460 mm is to be traversed, it can be demonstrated that using steps of up to 230 mm reduces the number of steps required from 3 to 2).

An external access step, fixed or moveable, shall have a maximum height of 230 mm between steps and a minimum depth of 150 mm. If a step board is fitted and it is an extension of a door sill outside the vehicle, and there is no change in level between the step board and the floor of

Status: This is the original version (as it was originally adopted).

the vehicle, this shall not be considered to be a step for the purposes of this specification. A minimal drop in level, with a maximum of 60 mm, between the floor surface of the vestibule and that of the exterior of the vehicle, used to guide and seal the door is also permissible and shall not be considered as a step.

Access to the vestibule of the vehicle shall be achieved with a maximum of 4 steps of which one may be external.

4.2.2.12.3 Boarding aids

4.2.2.12.3.1 General

Boarding aids shall comply with requirements as per the following table:

Use of the boarding aid	Not accessible to wheelchair user	Both wheelchair and other user accessible	Only accessible to wheelchair user
Boarding aid category*	Moveable step	Ramp	Lift
	Other devices	Bridging plate	Other devices
		Other devices	
General requirements according to:	category A	category A	category B
		category B	

4.2.2.12.3.2 Availability of boarding aids for wheelchair users

When a wheelchair-compatible doorway in a train is intended to be open, in normal operation, at a platform at a station that has obstacle free access routes in accordance with 4.1.2.3.1, a boarding aid shall be provided to be used between that doorway and the platform to allow a passenger in a wheelchair to board or alight, unless it is demonstrated that the gap between the edge of the door sill of that doorway and the edge of the platform is not more than 75 mm measured horizontally and not more than 50 mm measured vertically.

The position of the edge of the platforms for which Rolling Stock boarding aids are compatible, in accordance with the preceding paragraph, shall be declared in the characteristics of the Rolling Stock.

If the distance does not exceed 30 km between stations on the same route with platforms that the Rolling Stock shall use, and that are equipped with boarding aids for wheelchair users, then it shall not be mandatory for the Rolling Stock to carry such aids.

The responsible Infrastructure Manager (or Station Manager(s) if they are the responsible entities) and Railway Undertaking shall agree the management of the boarding aid in line with Regulation (EC) No1371/2007 on Rail Passengers' Rights and Obligations in order to establish which party is responsible for providing any necessary boarding aids. The Infrastructure Manager (or Station Manager(s) and Railway Undertaking shall ensure that the division of responsibilities they agree is the most viable overall solution.

Such agreements shall define:

- the station platforms where a boarding aid has to be provided by the Infrastructure Manager or the Station Manager and Rolling Stock for which it will be used,
- the station platforms where a boarding aid has to be provided by the Railway Undertaking and the Rolling Stock for which it will be used,

- the Rolling Stock where a boarding aid has to be provided by the Railway Undertaking and the station platform where it will be used,
- the specific rules for stopping the trains in order to comply with clause 4.1.2.19 (area for boarding aids for wheelchair users).

In its Safety Management System, the Railway Undertaking shall indicate what its obligations are according to such agreements, and how it intends to comply with them.

In its Safety Management System, the Infrastructure Manager shall indicate what its obligations are according to such agreements, and how it intends to comply with them.

In the paragraphs above, the Station Manager operating the platforms is considered as an Infrastructure Manager according to Directive 91/440/EC art 3: definition of Infrastructure and regulation 2598/70/EC.

4.2.2.12.3 General requirements category A Interoperability constituent requirements

The device shall be capable of withstanding a concentrated downward vertical load of 2 kN this shall be applied on an surface area of 100 mm * 200 mm at any position on the exposed step surface without causing permanent deformation;

The device shall be capable of withstanding on its exposed surface a distributed downward vertical load of 4 kN per metre of step length without causing significant permanent deformation.

A suitable mechanism shall be installed in order to ensure the stability of the device in the deployed and retracted position.

The device surface shall be slip resistant and shall have an effective clear width as large as the doorway width.

The device shall be fitted with a device capable of stopping the movement of that step if its front edge comes into contact with any object or person whilst the step is in movement.

The maximum force exerted by the device shall comply with the following:

The maximum force exerted by the device in opening direction shall not exceed the peak force of 300 N when hitting an obstacle.

Where passengers are expected to stand on a vertically moveable device inside a vehicle, the step shall not operate with a vertical force of = 150 N applied on an area of 80 mm diameter at any position of the step surface.

The device shall incorporate an emergency method of deploying and stowing if the power to the step fails.

4.2.2.12.3 General requirements category B Interoperability constituent requirements

If boarding aids are situated at stations, they shall accommodate a wheelchair with characteristics as detailed in Annex M:

The device surface shall be slip resistant and shall have an effective clear width of at least 760 mm, except for lifts for which 720 mm is permitted. If the plate is less than 900 mm wide, it shall have raised edges on both sides to prevent mobility aid wheels from slipping off.

The device shall withstand a weight of at least 300 kg, placed at the centre of the ramp distributed over an area of 660 mm by 660 mm.

4.2.2.12.35 Specific requirements for moveable steps

A moveable step is a device integrated into the vehicle, fully automatic and activated in conjunction with the door opening/closing sequences.

It is permitted to use moveable steps, provided they meet the requirements related to the chosen construction gauge of the Rolling Stock, according to Annex C of the Freight Wagon TSI.

In the case of the moving step extending beyond that permitted by the gauging rules, the train shall be immobilised whilst the step is extended.

The extension of the moveable step shall be completed before the door opening permits the passengers to cross and conversely, removal of the step may only begin when the door opening no longer permits any crossing of PRM passengers.

4.2.2.12.36 Specific requirements for portable ramps

Interoperability constituent requirements

When staff manually operate the device, it shall be designed for safety and shall require minimum effort for operation.

If the boarding device is power operated the boarding aid shall incorporate an emergency method of manual operation should power fail. Such a method shall be capable of being operated in a non-hazardous manner for both occupant and the operator.

An access ramp shall be either positioned manually by staff whether stored on the station platform or on board, or deployed semi-automatically by mechanical means, operated by staff or by the passenger.

The ramp surface shall be slip resistant and shall have an effective clear width of a minimum of 760 mm.

Ramps shall have raised edges on both sides to prevent mobility aid wheels from slipping off.

The upstands at both ends of the ramp shall be bevelled and shall not be higher than 20 mm. They shall have contrasting hazard warning bands.

When in use for boarding or alighting, the ramp shall be secured in use so that it is not subject to displacement when loading or unloading.

A secure compartment shall be provided to ensure that stowed ramps, including portable ramps, do not impinge on a passenger's wheelchair or mobility aid or pose any hazard to passengers in the event of a sudden stop.

A ramp slope shall have a maximum value of 10,2 degrees (18 %). This maximum value may require assistance to the passenger.

Subsystem requirements

A secure compartment shall be provided to ensure that stowed ramps, including portable ramps, do not impinge on a passenger's wheelchair or mobility aid or pose any hazard to passengers in the event of a sudden stop.

4.2.2.12.37 Specific requirements for semi-automatic ramps

Interoperability constituent requirements

A semi-automatic ramp shall be fitted with a device capable of stopping the movement of that step if its front edge comes into contact with anything or person whilst the plate is in movement.

A ramp slope shall have a maximum value of 10,2 degrees (18 %). This maximum value may require assistance to the passenger.

Subsystem requirements

A control shall ensure that the vehicle cannot be moved when a semi-automatic ramp is not stowed.

4.2.2.12.38 Specific requirements for bridging plates Interoperability constituent requirements

A bridging plate is a device integrated into the vehicle, fully automatic and activated in conjunction with the door opening/closing sequences. It remains horizontal without support on the station platform.

4.2.2.12.39 Specific requirements for on-board lifts Interoperability constituent requirements

An on-board lift is a device integrated into the doorway of a vehicle that shall be deployed by the train staff. The system shall be able to overcome the maximum height difference between the vehicle floor and the station platform where operated.

If an on-board lift is used, it shall comply with the following:

Where provided, each control for deploying, lowering to ground level, raising and stowing the lift shall require continuous manual pressure by the operator and shall not allow an improper lift sequencing when the lift platform is occupied.

The lift shall incorporate an emergency method of deploying, lowering to ground level with a lift occupant, and raising and stowing the empty lift if the power to the lift fails.

No part of the lift platform shall move at a rate exceeding 150 mm/second during lowering and lifting an occupant, and shall not exceed 300 mm/second during deploying or stowing (except if the lift is manually deployed or stowed). The maximum lift platform horizontal and vertical acceleration when occupied shall be 0,3 g.

The lift platform shall be equipped with barriers to prevent any of the wheels of a wheelchair from rolling off the lift platform during its operation.

A movable barrier or inherent design feature shall prevent a wheelchair from rolling off the edge closest to the vehicle until the lift is in its fully raised position.

Each side of the lift platform which extends beyond the vehicle in its raised position shall have a barrier a minimum 25 mm high. Such barriers shall not interfere with manoeuvring into or out of the aisle.

The loading-edge barrier (outer barrier) which functions as a loading ramp when the lift is at ground level, shall be sufficient when raised or closed, or a supplementary system shall be provided, to prevent a power wheelchair from riding over or defeating it.

The lift shall permit both inboard and outboard facing of wheelchair.

A secure stowage system shall be provided to ensure that the stowed lift does not impinge on a passenger's wheelchair or mobility aid or pose any hazard to passengers.

When the lift is in the stowed position the doorway shall have a minimum useable width of 800 mm.

Subsystem requirements

The lift shall ensure that the vehicle cannot be moved when the lift is not stowed.

4.2.3. Functional and technical specifications of the interfaces

Due to the fact that the Conventional Rail TSI's do not, currently, exist for passenger Rolling Stock and Infrastructure, this section remains an open point.

There is no interface with the Control Command and Signalling subsystem.

The interfaces with the Operation subsystem are described in section 4.1.4 'Operating Rules'.

4.2.4. Operating rules

The following operating rules do not form any part of the assessment of Rolling Stock.

This TSI does not specify operating rules for evacuation in the case of hazardous situations, only the relevant technical requirements. The purpose of the technical requirements for Rolling Stock is to facilitate evacuation for all, including PRM.

In light of the essential requirements in section 3, the operating rules specific to the Rolling Stock Subsystem according to the technical scope as defined in clause 1.1, concerned by this TSI, are as follows:

— *General*

The Railway Undertaking shall have a written policy to ensure that all categories of PRM can access the passenger Rolling Stock at all operational times in accordance with the technical requirements of this TSI. Furthermore, the policy shall be compatible with the Infrastructure Manager or station Manager policy (refer to Section 4.2.4) as appropriate. The policy shall be implemented through the provision of adequate information to staff, procedures and training. The Rolling Stock policy shall include, but not be limited to, operating rules for the following situations:

— *Access and Reservation of Priority Seats*

Two possible conditions exist in connection with seats classified as 'priority'; (i) unreserved and (ii) reserved (refer to Section 4.2.2.2.1). In case (i) the operating rules will be directed to other passengers (i.e. provision of signage) requesting them to ensure that priority is given to PRM of all categories that are defined as being eligible to use such seats and that occupied priority seats should be given-up as appropriate. In case (ii) operating rules shall be implemented by the Railway Undertaking to ensure that the ticketing reservation system is equitable with regards to PRM. Such rules will ensure that priority seating is initially only available for reservation by PRM until a given cut-off period prior to departure. This shall also include the possibility for a person with an assistance dog to reserve two spaces — one for the PRM and one for the dog. After this point in time, priority seats will be made available to the entire passenger population, including PRM.

— *Carriage of Assistance Dogs*

Operating rules shall be made to ensure that a PRM with an assistance dog shall not be charged extra.

— *Access and Reservation of Wheelchair Spaces*

The above priority seating access and reservation rules also apply to wheelchair spaces (refer to Section 4.2.2.3) except that wheelchair users are the only category of PRM with priority. Additionally, operating rules shall provide for (i) unreserved or (ii) reserved accompanying persons (non-PRM) seating adjacent or facing the WCU space. Drop-down seating allows for wheelchair spaces to be converted to universal seating.

— *Access and Reservation of Universal Sleeping Compartments*

The above priority seating reservation rules also apply to universal sleeping compartments (refer to Section 4.2.2.3). However, operational rules shall prevent non-reserved occupation of universal sleeping compartments (i.e. advanced booking will always be necessary).

— *Wheelchair User Space Alarm (Alarm system for wheelchair user)*

Operational rules shall be implemented to ensure appropriate response and action from the traincrew in the event of activation of the wheelchair users space emergency alarm (refer to 4.2.2.3).

— *Traincrew Exterior doors activation*

Operational rules shall be implemented regarding the procedure for external door activation by traincrew to ensure safety of all passengers including PRM (refer to Section 4.2.2.4.1).

— *Traincrew — Alarm system in universal toilets*

Operational rules shall be implemented to ensure appropriate response and action from the traincrew in the event of activation of the universal toilet emergency alarm (refer to 4.2.2.6.3) by any passenger including PRM.

— *Audible safety instructions in case of emergency*

Operational rules shall be implemented regarding the transmission of audible safety instructions to passengers in the event of an emergency (refer to Section 4.2.2.8.1). These rules shall include the nature of the instructions and of their transmission.

— *Visual Information — Control of Advertisements*

Operating rules shall be implemented to avoid any potential passenger distraction, by advertisements, of visual information (refer to Section 4.2.2.8.2). These rules shall address the relative positioning, dimensions and lighting of advertisements.

— *Automatic Information Systems — Manual Correction of incorrect or misleading information*

Operational rules shall be implemented for the validation and ability to correct erroneous automatic information by the traincrew (refer to Section 4.2.2.8).

— *Rules for announcement of the final destination and the next stop*

Operational rules shall be implemented to ensure that the next stop is announced no later than 2 minutes prior to the event (refer to Section 4.2.2.8).

— *Language to be used for announcements on board trains*

Onboard announcements can be recorded or live speech. In both cases, operational rules shall be implemented to justify the languages used, having due regard to the route(s) typical passenger nationality profile, concerning spoken language(s) (refer to Section 4.2.2.8).

— *Alarm system in sleeping compartments*

Status: This is the original version (as it was originally adopted).

Operational rules shall be implemented to ensure appropriate response and action from the traincrew in the event of activation of the sleeping compartment emergency alarm (refer to 4.2.2.11) by any passenger including PRM.

- *Rules on train composition to make wheelchair boarding aid devices usable according to the arrangement of the platforms*

Operation rules shall be implemented to take account of train composition variations such that the safe operational zones for wheelchair boarding aids can be determined with respect to the stopping point of trains.

- *Safety of Manual and Powered Wheelchair Boarding Aids*

Operations rules shall be implemented concerning the operation of boarding aids by train and station staff. In the case of manual devices, procedures shall ensure that minimum physical effort is required from staff. In the case of powered devices, procedures shall ensure emergency fail-safe-operation in the event of loss of power. An operational rule shall be implemented concerning the use by train or station staff of the moveable safety barrier fitted to wheelchair lifts.

Operational rules shall be implemented to ensure that train and station staff are able to safely operate boarding ramps, with respect to deployment, securing, raising, lowering and stowing.

- *Assistance to Wheelchair Users*

Operational rules shall be implemented to ensure that staff are aware that Wheelchair users may require assistance to board and alight the train, and shall provide such assistance if required.

PRM may be required to book such assistance in advance in order to ensure that trained staff are available.

- *Platform — Wheelchair Boarding Aid Operational Zone*

The Railway Undertaking and the Infrastructure Manager or Station Manager shall define together the area on the platform where the facility is likely to be used and shall demonstrate its validity. This area shall be compatible with the existing platforms where the train is likely to stop.

A consequence of above is that the stopping point of the train shall in some cases be adjusted in order to comply with this requirement.

Operational rules shall be implemented to take account of train composition variations (refer to Section 4.1.2.19) such that the stopping point of trains can be determined with respect to the boarding aid operational zones.

- *Emergency method to deploy moveable steps*

Operational rules shall be implemented for the emergency stowage or deployment of the bridging plate in the case of power failure.

- *Carriage of pushchairs*

Operational rules shall be implemented for the carriage of pushchairs.

- *Carriage of luggage*

Operational rules shall be implemented for the carriage of luggage.

- *Operating combinations of PRM — TSI compliant and non-compliant Rolling Stock*

When forming a train from a mixture of compliant and non-compliant Rolling Stock, operational procedures shall be implemented to ensure that a minimum of two PRM — TSI compliant wheelchair spaces are provided on the train. Also it shall be ensured that if toilets are available on the train, the wheelchair user has access to a universal toilet.

Under such Rolling Stock combinations, procedures shall be in place to ensure that visual and audible route information is available on all vehicles.

It is accepted that dynamic information systems and wheelchair space/universal toilet alarm devices may not be fully functional when working in such formations.

— *Forming trains from individual TSI — PRM compliant vehicles*

When vehicles that have been individually assessed in accordance with Section 6.2.7 are formed into a train, operational procedures shall be in place to ensure that the complete train complies with all relevant clauses of section 4.2 of this TSI.

4.2.5. Maintenance rules

In light of the essential requirements in section 3, the maintenance rules specific to the Rolling Stock Subsystem according to the technical scope as defined in clause 1.1, concerned by this TSI, are as follows:

If a facility that has been incorporated for PRM becomes defective (this includes tactile signs), the Railway Undertaking shall ensure that he has procedures for the facility to be repaired or replaced within 6 working days of the occurrence being reported.

4.2.6. Professional qualifications

The professional qualifications of staff required for the operation and maintenance of the Rolling Stock Subsystem according to the technical scope as defined in clause 1.1, and according to clause 4.2.4 giving the list of operational rules, concerned by this TSI, are as follows:

Professional training of staff performing the tasks of accompanying trains, delivering service and help for passengers at a station and of selling tickets shall include the subject of disability awareness and equality, including the specific needs of each category of PRM.

Professional training of engineers and managers, responsible for maintaining and operating the trains, shall include the subject of disability awareness and equality, including the specific needs of each category of PRM.

4.2.7. Health and safety conditions

There are no specific requirements in the scope of this TSI related to the health and safety conditions of staff required for the operation of the Rolling stock nor for the implementation of the TSI.

4.2.8. Rolling Stock register

The requirements for the Rolling Stock Register with regard to this TSI are as specified below.

The Rolling Stock Register shall include the following general information about each type of Rolling Stock:

- A general description of the type of Rolling Stock (including the maximum operating speed and number of fixed seats);
- The Railway Undertaking operating the Rolling Stock, and, if different, the owner of the Rolling Stock;

Status: This is the original version (as it was originally adopted).

- The Member State approving the Rolling Stock for the purposes of this TSI;
- The class number and individual vehicle numbers of the Rolling Stock;
- The builder of the Rolling Stock;
- The date of entry into public passenger service of the Rolling Stock;
- The routes for which the Rolling Stock is permitted to be operated;
- The date of declaration of conformity of the Rolling Stock with the requirements of this TSI;
- The name of the Notified Body certifying that conformity;
- The train configuration(s) of the Rolling Stock when operated in conformance with this TSI;

In addition for each item of Rolling Stock the following features shall be listed and described with respect to the relevant clauses in the TSI, as follows:

- The number of Priority Seats in accordance with Clause 4.2.2.2;
- The number of wheelchair spaces accordance with Clause 4.2.2.3;
- The number of Toilets in accordance with Clause 4.2.2.6;
- The number of Wheelchair Accessible Sleeping places if provided in accordance with Clause 4.2.2.11;
- The vehicle floor height, and the position of all steps provided for vehicle access and egress in accordance with Clauses 4.2.2.12.1, 4.2.2.12.2 and 4.2.2.12.3;
- The platform heights (including any specific cases) with which the Rolling Stock is designed to be compatible in accordance with Clause 4.2.2.12.1;
- The description of any integrated boarding aids if provided in accordance with Clause 4.2.2.12.4;
- The description of any portable boarding aids that are as a matter of course carried on the Rolling Stock in accordance with Clause 4.2.2.12.4;

Where National Rules have been applied in order to establish conformance with this TSI, the relevant rules and clauses shall be stated against the relevant item in the register.

If the Member State of registration changes, the contents of the Rolling Stock Register for that Rolling Stock relating to this TSI shall be passed from the original State of registration to the new State of registration.

The data contained in the Rolling Stock Register is required by :

- The Member State to confirm that the Rolling Stock meets the requirements of this TSI;
- The Infrastructure Manager to confirm that the Rolling Stock is compatible with the Infrastructure over which it is intended to be operated;
- The Railway Undertaking to confirm that the Rolling Stock is suitable for its requirements.

4.3. Definitions of terms used in this TSI

Palm Operated

Palm Operated means that the device shall be operable by the palm or any part of the hand in its working position, not requiring fingers to be unclenched. The design need is that passengers with painful conditions, which affect their joints such as arthritis, may be unable to (and are likely to experience discomfort or pain if they do) exert any force with the tip of a single finger. Many will not be able to unclench their fingers to do this.

Contrast

When applying colour to two adjacent surfaces, to provide sufficient contrast, the contrast between the colours will be determined by the light reflectance value, the hue and by the chromatic value of each.

For the purposes of this TSI 'Contrast' shall be assessed by the diffused light reflectance value, but may be enhanced by variation in hue and chroma.

'Contrast by the diffused light reflectance value' shall mean contrast of surfaces described in the following formula:

$$K = \frac{(L_0 - L_h)}{L_0 + L_h}$$

- | | |
|----------------|-------------------------------------------------------------------------------|
| K | = contrast |
| L ₀ | = the diffused light reflectance value of the object. |
| L _h | = the diffused light reflectance value of the background or adjacent surface. |

When contrast is specified in this TSI there shall be a minimum value of K = 0,3.

Where L is the luminous intensity of the diffused light reflected in a given direction from an element of the surface, divided by the area of the element projected in the same direction.

A combination of the colours red and green is not allowed for contrast.

The measurement of the diffused light reflectance value shall be carried out in accordance with European or National standards.

The level of contrast in hue will be determined by the proximity of the two colours within the colour spectrum, so that colours that are close to each other within the spectrum will contrast less well than those that are further apart.

The value of chroma in any colour definition describes its intensity and the level of its saturation. The more heavily a colour is saturated, the greater its intensity will be.

First Step

The 'First Step', means the first step of a vehicle that a passenger shall use to board or alight a train. This will normally be the step that is closest to the platform edge. It may be a fixed or a moveable step.

Slip Resistant

'Slip resistant' means that any surface finish used should be sufficiently rough or otherwise specially formulated so that friction between the surface, and a person's shoe or a mobility aid, is maintained at an acceptable level in both wet and dry conditions.

It is noted that there is no unique or universally accepted system of determining the co-efficient of friction when defining slip resistance of floor surfaces.

For Rolling Stock, therefore, it shall be sufficient to demonstrate that the static co-efficient of friction between a designated 'slip resistant' surface and a rubber soled shoe achieves a minimum value of 0,35 even when the surface is wetted by clean water, as measured using a nationally, or internationally, recognised testing method. The grade of rubber used in the test shall be declared with the test results and shall be representative of the types of material used in the manufacture of shoes sold for everyday wear in the member states of the European Union.

For Infrastructure, National Rules relating to equivalent designated surfaces in buildings shall apply.

'Tactile Signs' and 'Tactile Controls'

‘Tactile signs’ and ‘tactile controls’ are signs, or controls, including raised pictograms, raised characters or Braille lettering. For tactile pictograms and characters the depth shall be a minimum of 0,5 mm raised above the surface and shall not be engraved and shall be square edged (i.e. not rounded or sharp).

The character or pictogram spacing should allow for both sides of the embossed letter, number or symbol to be felt with the fingers in a single pass.

The minimum character or number height shall be 15 mm.

National Standard Braille shall be used wherever Braille characters are used. The Braille dot shall be dome shaped. Grade I Braille shall be used for single words, and a locator shall be incorporated.

Station Manager

The Station Manager is the entity responsible for day-to-day management of a station. This role may be discharged by the Railway Undertaking, the Infrastructure Manager or a third party.

Safety Information

Safety information is information that shall be given to passengers in order that they may know in advance how they will have to behave in case of an emergency.

Safety Instructions

Safety instructions are the instructions that shall be given to passengers when an emergency occurs in order that they may understand what to do.

Clearway

A clearway is the unobstructed space to allow movement within a vehicle to areas as designated in chapter 4.

Gangway

A gangway is the means for passengers to pass from one vehicle of a train to the next vehicle.

5. INTEROPERABILITY CONSTITUENTS

5.1. Definition

According to Article 2(d) of Directive 2001/16/EC modified by Directive 2004/50/EC, the interoperability constituents are ‘any elementary component, group of components, subassembly or complete assembly of equipment incorporated or intended to be incorporated into a subsystem upon which the interoperability of the trans-European conventional rail system depends directly or indirectly. The concept of a constituent covers both tangible objects and intangible objects such as software’.

5.2. Innovative solutions

As stated in section 4 of this TSI, innovative solutions may require new specification and/or new assessment methods. These specifications and assessment methods shall be developed by the process described in clause 6.1.3.

5.3. List of constituents

The interoperability constituents are covered by the relevant provisions of Directive 2001/16/EC modified by Directive 2004/50/EC and are listed below.

5.3.1. Infrastructure

The following items are identified as being interoperability constituents for Infrastructure:

Passenger visual information equipment

Boarding aids

Pushbuttons

Baby changing unit

Tactile signage

Ticket vending machines

5.3.2. Rolling stock

The following items are identified as being interoperability constituents for Rolling Stock:

Standard and universal toilet modules

Passenger information equipment (audible and visual)

Passenger alarm devices

Boarding aids

Pushbuttons

Baby changing unit

Visual and tactile signage

5.4. Constituents' performances and specifications

5.4.1. Infrastructure

The characteristics to be respected are given in the relevant clauses of section 4.1 indicated below.

Visual passenger information equipment (4.1.2.11.2 and Annex N.)

Boarding devices (4.1.2.21.2)

Tactile pushbuttons (4.1.2.4)

Baby changing unit (4.1.2.7.2)

Tactile signage (4.1.2.11)

Ticket vending machines (4.1.2.9.2)

5.4.2. Rolling Stock

The characteristics to be respected are given in the relevant clauses of section 4.2 indicated below.

Toilet modules (4.2.2.6)

Visual passenger information equipment (4.2.2.8.3 and Annex N)

Passenger alarm devices:

The alarm devices shall be operable by the palm of a person's hand and shall not require a force exceeding 30 N to operate.

Boarding devices (4.2.2.12.3)

Pushbuttons:

Pushbuttons shall be operable by a force not greater than 15 Newtons

Baby changing unit (4.2.2.6.3.2)

Visual and tactile signage (4.2.2.8.1, 4.2.2.8.2 and Annex N)

6. ASSESSMENT OF CONFORMITY AND/OR SUITABILITY FOR USE

6.1. Interoperability constituents

Status: This is the original version (as it was originally adopted).

6.1.1. Conformity assessment (general)

An EC declaration of conformity or an EC declaration of Suitability for Use in accordance with Article 13(1) and Annex IV Chapter 3 of Directive 2001/16/EC modified by Directive 2004/50/EC shall be drawn up by the manufacturer or his authorised representative established within the Community before placing an interoperability constituent on the market.

The Conformity Assessment of an Interoperability Constituent shall be done according to the following modules (The modules are described in Annex F to this TSI):

Modules for interoperability constituents:

Module A: Internal production control for design, development and production phases

Module A1: Internal design control with product verification for design, development and production phases

Module B: Type examination for design and development phases

Module C: Conformity to type for production phase

Module D: Production quality management system for production phase

Module F: Product verification for production phase

Module H1: Full quality management system for design, development and production phases

Module H2: Full quality management system with design examination for design, development and production phases

Module V: Type validation by in service experience (Suitability for use)

If the participation of a notified body is required for the appropriate module,

- The approval process and the contents of the assessment shall be defined between the manufacturer or his authorised representative established within the Community and a notified body, according to the requirements defined in this TSI.
- For each interoperability constituent as appropriate the notified body to be chosen by the manufacturer shall have been authorised either:

to assess the Rolling Stock subsystem Interoperability Constituents and/or to assess the Infrastructure subsystem Interoperability Constituents.

6.1.2. Conformity assessment procedures (modules)

The conformity assessment shall cover the phases and characteristics as indicated by X in Table D1 of Annex D to this TSI. The manufacturer or his authorised representative established within the Community shall chose one of the modules or module combinations indicated in the following Table 16 according the required constituent.

TABLE 16

Assessment procedures

Clause	Constituent to be assessed	Module A	Module A1 ^a	Module B + C	Module B + D	Module B + F	Module H1 ^a	Module H2
--------	----------------------------	----------	------------------------	--------------	--------------	--------------	------------------------	-----------

^a Modules A1 and H1 are allowed for existing solutions only under conditions defined in clause 6.1.3.

4.1.2.11.2 and 4.1.2.12.2	Visual passenger information equipment		X	X	X		X	X
4.1.2.21.2	Boarding devices		X		X	X	X	X
4.1.2.4	Tactile pushbuttons	X		X			X	
4.1.2.7.2	Baby changing unit	X		X			X	
4.1.2.11	Tactile signage	X		X			X	
4.1.2.9.2	Ticket vending machines	X		X			X	
4.2.2.6	Toilet modules		X	X	X		X	X
4.2.2.8	Visual passenger information equipment		X	X	X		X	X
4.2.2.3, 4.2.2.6 and 4.2.2.11	Passenger alarm devices	X		X			X	
4.2.2.12.3	Boarding devices		X		X	X	X	X
4.2.2.4	Pushbutton s			X			X	
4.2.2.6.3.2	Baby changing unit	X		X			X	
4.2.2.8.1, 4.2.2.8.2 and Annex N	Visual and tactile signage	X		X			X	

^a Modules A1 and H1 are allowed for existing solutions only under conditions defined in clause 6.1.3.

6.1.3. Innovative solutions

If an innovative solution is proposed for an interoperability constituent, as defined in section 5.2, the manufacturer or his authorised representative established within the Community shall state the deviations from the relevant clause of the TSI and submit them to the European Railway Agency (ERA). The ERA shall finalise the appropriate functional and interface specifications for the constituents and develop the assessment methods.

The appropriate functional and interface specifications and the assessment methods so produced shall be incorporated in the TSI by the revision process.

After entry into force of a decision of the Commission, taken in accordance with Article 21(2) of Directive 2001/16/EC, as modified by Directive 2004/50/EC, the innovative solution is permitted to be used before being incorporated into the TSI.

6.1.4. Assessment of suitability for use

Assessment of Suitability for Use according to the type validation of in service experience procedure (module V) as indicated in Annex F of this TSI is required for the following Interoperability Constituents:

None

6.2. Subsystems

6.2.1. Conformity assessment (general)

In accordance with Annex VI of the Directive 96/48/EC, the contracting entity, or its authorised representative established within the the community (applicant) shall lodge an application for assessment of conformity of the Rolling Stock or Infrastructure Subsystem with a notified body of its choice.

Lodging an application for assessment of conformity of Rolling Stock by the manufacturer remains an open point (see DV11 Question 3)

This notified body shall have been notified to assess the Rolling Stock or Infrastructure Subsystem.

The EC declaration of verification in accordance with Article 18(1) and Annex VI to Directive 2001/16/EC modified by Directive 2004/50/EC shall be drawn up by the applicant.

This EC declaration of verification is required to obtain the authorisation to place the Subsystem into service.

The Conformity Assessment of a Subsystem shall be performed according to one or a combination of the following modules according to clause 6.2.2 and annex E to this TSI (The modules are described in Annex F to this TSI):

Modules for the EC verification of subsystems

Module SB: Type examination for design and development phases

Module SD: Product quality management system for production phase

Module SF: Product verification for production phase

Module SG: Unit verification

Module SH2: Full quality management system with design examination for design, development and production phases

The approval process and the contents of the assessment shall be defined between the applicant and a notified body according to the requirements defined in this TSI and in conformance with the rules set out in section 7 of this TSI.

6.2.2. Conformity assessment procedures (modules)

The applicant shall choose one of the modules or module combinations indicated in Table 17.

TABLE 17

Assessment procedures

Subsystem to be assessed	Module SB + SD	Module SB + SF	Module SG	Module SH2
Rolling Stock Subsystem	X	X		X
Infrastructure Subsystem	X		X	X

The characteristics of the Subsystem to be assessed during the relevant phases are indicated in Annex E to this TSI, Table E.1 for Infrastructure subsystem and Table E.2 for Rolling Stock subsystem. The applicant shall confirm that each subsystem produced complies with the type.

Characteristics of Interoperability Constituents that are indicated in Annex D, Table D1, also appear in Annex E, Table E.1 or E.2. Assessment of these characteristics is covered by the presence of the EC declaration of conformity of the interoperability constituent.

The assessment of the maintenance subsystem is described in clause 6.2.5.

6.2.3. Innovative solutions

If a Subsystem includes an innovative solution as defined in section 4.1.1 or 4.2.1, the manufacturer or the contracting entity shall state the deviation from the relevant clause of the TSI and submit them to the European Railway Agency (ERA). The ERA shall finalise the appropriate functional and interface specifications of this solution and develop the assessment methods.

The appropriate functional and interface specifications and assessment methods shall be incorporated in the TSI by the revision process.

After entry into force of a decision of the Commission, taken in accordance with Article 21(2) of Directive 2001/16/EC, as modified by Directive 2004/50/EC, the innovative solution is permitted to be used before being incorporated into the TSI.

6.2.4. Assessment of maintenance

According to article 18.3 of Directive 2001/16/EC as modified by Directive 2004/50/EC, the Notified Body shall compile the Technical File, which includes the Maintenance File. That means in particular that the Notified Body shall verify:

- the existence of the maintenance file,
- the existence for Rolling Stock inside the maintenance file of the items detailed in clause 4.2.10.2 of the HS RST TSI,

but it does not have to check the validity of the content of the maintenance file.

The conformity assessment of maintenance is the responsibility of each member state concerned.

The clause F.4 of Annex F (which is an open point) describes the procedure by which each member state ascertains that maintenance arrangements meet the provisions of this TSI and ensure the respect of the basic parameters and essential requirements during the domain lifetime

6.2.5. Assessment of operational rules

Conventional Rail Operation TSI, clause 6.2.1 says that at present none of the elements contained within the CR OPE TSI require separate assessment by a Notified Body.

For the purpose of this PRM TSI, the Notified Body shall not verify any operational rule, even if they are listed in clause 4.1.4 or 4.2.4.

6.2.6. Assessment of individual vehicles

When Rolling Stock is supplied as individual vehicles, rather than in fixed consists, such vehicles shall be assessed against the relevant clauses of this TSI, accepting that not every such vehicle will have wheelchair spaces, wheelchair accessible facilities or a universal toilet.

However, it shall be demonstrated that when formed into a complete train with other compatible vehicles, all clauses of the TSI — PRM can be complied with.

6.3. Interoperable Constituents Not Holding an EC Declaration

6.3.1. General

For a limited period of time, known as the ‘transition period’, interoperability constituents not holding an EC Declaration of Conformity or Suitability for Use may exceptionally be incorporated into subsystems, on the condition that the provisions described in this section are met.

6.3.2. The Transition Period

The transition period shall commence from the entry into force of this TSI and shall last for six years.

Once the transition period has ended, and with the exceptions allowed under section 6.3.3.3 below, interoperability constituents shall be covered by the required EC declaration of conformity and/or suitability for use before being incorporated into the subsystem;

6.3.3. The Certification of Subsystems Containing Non-Certified Interoperability Constituents during the Transition Period

6.3.3.1. Conditions

During the transition period a Notified Body is permitted to issue a certificate of conformity for a subsystem, even if some of the interoperability constituents incorporated within the subsystem are not covered by the relevant EC declarations of conformity and/or suitability for use according to this TSI, if the following three criteria are complied with:

- the conformity of the subsystem has been checked in relation to the requirements defined in chapter 4 of this TSI by the Notified Body, and
- through carrying out additional assessments the Notified Body confirms that the conformity and/or the suitability for use of the interoperability constituents is in accordance with the requirements of chapter 5, and
- the interoperability constituents, which are not covered by the relevant EC declaration of conformity and/or suitability for use, shall have been used in a subsystem already put in service in at least one of the Member States before the entry in force of this TSI.

EC Declarations of conformity and/or suitability for use shall not be drawn up for the interoperability constituents assessed in this manner.

6.3.3.2. Notification

- the certificate of conformity of the subsystem shall indicate clearly which interoperability constituents have been assessed by the Notified Body as part of the subsystem verification.
- the EC declaration of verification of the subsystem shall indicate clearly:
 - Which interoperability constituents have been assessed as part of the subsystem
 - Confirmation that the subsystem contains the interoperability constituents identical to those verified as part of the subsystem.
 - For those interoperability constituents, the reason(s) why the manufacturer did not provide an EC Declaration of conformity and/or suitability for use before its incorporation into the subsystem.

6.3.3.3. Lifecycle Implementation

The production or upgrade/renewal of the subsystem concerned must be completed within the six years of the transition period. Concerning the subsystem lifecycle:

- During the transition period and
- under the responsibility of the body having issued the declaration of EC verification of the subsystem

the interoperability constituents which do not hold an EC declaration of conformity and/suitability for use and are of the same type built by the same manufacturer are permitted to be used for maintenance related replacements and as spare parts for the subsystem.

After the transition period has ended and

- until the subsystem is upgraded, renewed or replaced and
- under the responsibility of the body having issued the declaration of EC verification of the subsystem

the interoperability constituents which do not hold an EC declaration of conformity and/suitability for use and are of the same type built by the same manufacturer may continue to be used for maintenance related replacements.

6.3.4. Monitoring Arrangements

During the transition period Member States shall monitor:

- The number and type of interoperability constituents introduced on the market within their own State;
- Ensure that, where a subsystem is presented for authorisation, reasons for non-certification of the interoperability constituent by the manufacturer are identified;
- Notify, to the Commission and to the other Member States, the details of the non-certified IC and the reasons for non-certification.

7. IMPLEMENTATION OF THE PRM TSI

This chapter indicates the strategy for implementing the TSI. In particular, it is necessary to specify the stages to be completed in order to make a gradual transition from the existing situation to the final situation in which compliance with the TSI shall be the norm. This chapter is based on the need to co-ordinate the implementation of the TSI primarily for technical or operational reasons, but it takes due account of the cost-benefit analysis in conformity with the relevant provisions of the Directive. In addition, account shall be taken of the fact that implementation of a TSI occasionally has to be co-ordinated with the implementation of other TSIs.

The implementation of the TSIs shall take into consideration the overall migration of the conventional and high speed rail network towards full interoperability.

In order to support this migration, the TSIs allow for staged, gradual application and co-ordinated implementation with other TSIs.

7.1. Application of this TSI to new Infrastructure/Rolling Stock

7.1.1. Infrastructure

Infrastructure aspects of chapters 2 to 6 of this TSI and any specific provisions below apply in full to new Infrastructure being placed into service.

This clause of the TSI does not apply to new Infrastructure being subject to a contract already signed or under final phase of tendering procedure at the date of entry into force of this TSI.

The Infrastructure Manager or the Railway Undertaking or the Station Manager, in charge of a railway station, shall organise consultation with the entities in charge of the management of the neighbourhood in all cases of new construction of the station or of the neighbourhood, in order to enable the accessibility requirements to be met not only in the station, but also for access to the station.

7.1.2. Rolling Stock

7.1.2.1. General

Rolling Stock aspects of chapters 2 to 6 of this TSI and any specific provisions below apply in full to new Rolling Stock being placed into service.

This TSI does not apply to new Rolling Stock being subject to a contract already signed or under final phase of tendering procedure at the date of entry into force of this TSI.

7.1.2.2. Newly built Rolling Stock of new design

7.1.2.2.1. Definitions

For the purpose of this section 7.1.1 and of section 7.1.2.1:

- Phase A period is the period starting when a Notified Body is appointed and provided with a description of the Rolling Stock intended to be developed and built or acquired.
- Phase B period is the period starting when a type or design examination certificate of ‘EC’ verification is issued by a Notified Body, and ending when type or design examination certificate of ‘EC’ verification ceases to be valid.

7.1.2.2.2. General

- The type or design examination certificate of ‘EC’ verification for subsystem and/or
- type or design examination certificate of conformity and/or suitability for use for Interoperability constituents

are permitted to be requested by any applicant as defined in clauses 6.2.1 and 6.1.1 respectively.

The applicant shall announce its intent for development and assessment of new Rolling Stock and/or IC to the Notified Body chosen in accordance with Chapter 6 of this TSI. Together with this announcement, the applicant shall provide a description of the Rolling Stock or of the IC it intends to develop and build or acquire.

7.1.2.2.3. Phase A

Following the date of appointment of the notified body, the certification basis to the currently valid TSI at the date of the appointment for the specified Rolling Stock shall be fixed for a seven year phase A period, except in case of use of article 19 of Directive 96/48/EC as modified by Directive 2004/50/EC.

When a revised version, including this one, of the TSI comes into force during the phase A period it is permissible to use the revised version, either totally or for discrete sections, if both the applicant and the notified body agree to do so. These arrangements shall be documented.

After a positive assessment, the Notified Body shall issue the type or design examination certificate of 'EC' verification for the subsystem or the type or design examination certificate of conformity and/or suitability for use for the interoperability constituent.

7.1.2.2.4. Phase B

a) *Subsystem requirements*

This type or design examination certificate for the subsystem is valid for a seven year phase B period even if a new TSI comes into force except in case of use of article 19 of Directive 96/48/EC as modified by Directive 2004/50/EC. During this time, Rolling Stock of the same type is permitted to be placed into service without a new type assessment.

Before the end of the seven year phase B period, Rolling Stock shall be assessed according to the TSI in force at that time for those requirements that have changed or are new in comparison to the certification basis.

- If a derogation is requested and accepted, the existing type or design examination certificate of 'EC' verification remains valid for another three year phase B period. Before the end of the three years the same process of assessment and application for derogation is permitted to take place again.
- If the design of the subsystem is compliant the type or design examination certificate of 'EC' verification shall remain valid for a further seven year phase B period.

In the event that no new TSI comes into force before the end of the phase B period, assessment of the Rolling Stock is not required and the relevant certification shall remain in force for a further seven year phase B period.

b) *Interoperability constituent requirement*

The type or design examination or suitability for use certificate is valid for a five year phase B period even if a new TSI comes into force except in case of use of article 19 of Directive 96/48/EC as modified by Directive 2004/50/EC. During this time, new constituents of the same type are permitted to be placed into service without an assessment.

Before the end of the five-year phase B period, constituent shall be assessed according to the TSI in force at that time for those requirements that have changed or are new in comparison to the certification basis.

7.1.2.3. Rolling Stock of an existing design

Rolling stock, whose design is not certified in accordance with the TSIs shall be subject to the conditions described in section 7.5.2

7.1.2.4. Transitional Period

Member States may not apply the TSI for a transitional period, which will last until 1st January 2010. This allowance is restricted to the case of:

- contracts already signed or under the final phase of the tendering procedure at the date of entry into force of this TSI, and options to these contracts to purchase additional vehicles, or
- contracts for purchasing new rolling stock of an existing design type signed during this transitional period

7.2. TSI Revision

In conformity with article 6(3) of Directive 2001/16/EC as modified by Directive 2004/50/EC, the Agency shall be responsible for preparing the review and updating of TSIs and making appropriate recommendations to the Committee referred to in Article 21 of this directive in order to take account of developments in technology or social requirements. In addition, the progressive adoption and revision of other TSIs may also impact this TSI. Proposed changes to this TSI shall be subject to rigorous review and updated TSIs will be published on an indicative periodic basis of 3 years.

The Agency shall be notified of any innovative solutions under consideration in order to determine its future inclusion within the TSI.

7.3. Application of this TSI to existing Infrastructure/Rolling Stock

With regard to existing Infrastructure and Rolling Stock, this TSI applies to components that are renewed or upgraded in accordance with the conditions laid down in Article 14(3) of the Directive.

7.3.1. Infrastructure

Existing Infrastructure is Infrastructure that is in service at the date of entry when this TSI comes into force.

The TSI does not apply to existing Infrastructure until it is renewed or upgraded.

This TSI does not apply to Infrastructure being renewed or upgraded under the terms of a contract already signed, or under final phase of tendering procedure, at the date of entry into force of this TSI.

The Infrastructure Manager or the Railway Undertaking or the Station Manager, in charge of a railway station, shall organise consultation with the entities in charge of the management of the neighbourhood in all cases of upgrade or renewal of the station or of the neighbourhood, in order to enable the accessibility requirements to be met not only in the station, but also for access to the station.

When renewed or upgraded, existing stations **that have a daily passenger flow of 1 000 passengers or less, combined embarking and disembarking, averaged over a 12 month period** are not required to have lifts or ramps where these would otherwise be necessary to achieve full compliance with this clause if another station within 50 km on the same route provides a fully compliant obstacle-free route. In such circumstances the design of stations shall incorporate provision for the future installation of a lift and/or ramps to make the station accessible to all categories of PRM.

7.3.1.1. General

Where items are renewed or upgraded, they shall comply with the requirements of this TSI, with the following exceptions:

Where Infrastructure upgrade or renewal work affects aspects of the Infrastructure governed by any clause of this PRM TSI, it shall be reassessed in accordance with that requirement within this TSI, subject to the following conditions:

Compliance with the content of this TSI is not mandatory if the work that would be necessary to achieve compliance requires structural alterations to any load bearing element.

Systems and components that are not included in the scope of a particular upgrade or renewal programme do not have to be made compliant at the time of such a programme.

In the event that Infrastructure is re-assessed against any other TSI as a result of renewal or upgrading works, it shall only require re-assessment against this TSI in respect of those systems and components directly affected by the works.

There shall be two kinds of Infrastructure blocks

- Station buildings (including parking areas, toilets, sales office, etc.)
- Platforms

When any complete block is upgraded or renewed, it shall incorporate an obstacle free route (when applicable) that can be linked to the other blocks as and when they are upgraded or renewed.

The normal maintenance of the Infrastructure items shall not imply a reassessment within the limits of this TSI.

7.3.1.2. Obstacles-free routes — General (4.1.2.4.1)

Compliance with requirements related to dimensions of footbridges and subways in respect of width and/or headroom is not mandatory for existing footbridges and subways.

7.3.1.3. Geometry of footbridges, stairways and subways (4.1.2.14 and 4.1.2.15)

Compliance with requirements related to dimensions of footbridges, stairways and subways in respect of width and/or headroom is not mandatory for existing footbridges, stairways and subways.

7.3.1.4. Ramps, escalators, lifts and travelators (4.1.2.17)

Compliance with requirements related to ramps, escalators, lifts and travelators is not mandatory for existing ramps, escalators, lifts and travelators.

7.3.1.5. Platform width and edge of platform (4.1.2.19)

Compliance with requirements related to the minimum width of the platform is not mandatory for existing stations if the cause of non-compliance is the presence of certain platform obstacles (e.g. structural columns, stairwells, lifts etc.) that are unlikely to be moveable.

7.3.1.6. Platform height and offset (4.1.2.18)

Compliance with requirements related to platform height and offset is not mandatory in the case of renewed platforms, but remains mandatory for upgraded platforms.

7.3.1.7. Buildings of an historic nature

Where an existing station, or a part of it, is a recognised historic building and is protected by National Law, the Infrastructure Operator shall endeavour to implement the contents of this TSI. However, where it can be demonstrated that the National law for the protection of the

building would be infringed, implementation of the relevant requirements of this TSI shall not be mandatory.

7.3.2. Rolling Stock

Existing Rolling Stock is Rolling Stock that has been in service, or has been subject to a contract already signed or under final phase of tendering procedure at the date of entry into force of this TSI.

The TSI does not apply to existing Rolling Stock as long as it is not renewed or upgraded.

This clause of the TSI does not apply to Rolling Stock being renewed or upgraded under the terms of a contract already signed or under final phase of tendering procedure at the date of entry into force of this TSI.

7.3.2.1. General

Where Rolling Stock upgrade or renewal work affects aspects of the Rolling Stock governed by any clause of this PRM TSI, it shall be reassessed in accordance with that requirement within this TSI, subject to the following conditions:

Systems and components that are not included in the scope of a particular upgrade or renewal programme do not have to be made compliant at the time of such a programme.

In the event that a vehicle is re-assessed against any other TSI as a result of renewal or upgrading works, it shall only require re-assessment against this TSI in respect of those systems and components directly affected by the works.

Compliance with the content of this TSI is not mandatory if the work that would be necessary to achieve compliance requires structural alterations to door portals (interior or external), underframes, collision pillars, vehicle bodies, vehicle over-ride protection or any work that would necessitate re-validation of the vehicle structural integrity in accordance with EN 12663:July 2001 and/or other TSIs.

7.3.2.2. Seats

Compliance with clause 4.2.2.1 with regard to seat back grab handles is only mandatory if the seat structures are renewed or upgraded within an entire vehicle.

Compliance with clause 4.2.2.2 with regard to provision of priority seating is only mandatory if the seating layout is altered within an entire train and this can be achieved without reducing the existing capacity of the train. In the last circumstance the maximum number of priority seats shall be provided, whilst maintaining existing capacity.

Compliance with requirements regarding headroom above priority seating is not mandatory if the limiting factor is a luggage rack that is not being structurally altered during the renewal or upgrading work.

7.3.2.3. Wheelchair Spaces

Compliance with wheelchair space requirements is only required when the seating layout is altered within a complete train formation. However, if the entrance doorway, or clearways, cannot be modified to enable wheelchair access, a wheelchair space needs not be provided if the seating layout is altered.

The provision of emergency contact devices at the wheelchair positions is not mandatory if the vehicle does not have an electrical communications system that can be adapted to include such a device.

7.3.2.4. Exterior doors

Compliance with requirements to define the exterior of doorways by signage and contrast is only mandatory when the vehicle is repainted (or otherwise reliveried).

Compliance with requirements to define the interior position of external doorways by contrast at floor level is only mandatory when the floor covering is renewed or upgraded.

Compliance with requirements to provide door opening and closing signals is only mandatory when the door control system is renewed or upgraded.

Full compliance with requirements regarding the position and illumination of door controls is only mandatory when the door control system is renewed or upgraded and when the controls can be re-positioned without alteration to the vehicle structure or door. However, in such an event, the renewed or upgraded controls shall be installed as close as possible to the compliant position.

7.3.2.5. Interior doors

Compliance with the requirements for door control operation operating forces and positioning is only mandatory if the door and door mechanism and/or control is being upgraded or renewed.

Compliance with the requirement to make inter-vehicle and consecutive connecting doors operate synchronously is only mandatory if the doors are already automated, the door control system is being renewed or upgraded and there is a suitable inter-vehicle communications control system.

7.3.2.6. Lighting

Compliance with the requirement to provide step lighting, in accordance with Clause 4.2.2.5, at external doorways is not required if it can be established that there is insufficient capacity in the electrical system to support additional load, or that such lighting cannot usefully be accommodated without structural alteration to the doorway.

7.3.2.7. Toilets

Provision of a fully compliant universal toilet is only mandatory when existing toilets are being completely renewed or upgraded and a wheelchair space is provided and a compliant universal toilet can be accommodated without structural alteration to the vehicle body.

The provision of emergency contact devices in the universal toilet is not mandatory if the vehicle does not have an electrical communications system that can be adapted to include such a device.

7.3.2.8. Clearways

Compliance with the requirements of Clause 4.2.2.7 is only mandatory if the seating layout is altered within an entire vehicle and a wheelchair space is being provided.

Compliance with the requirements for clearways between connecting vehicles is only mandatory if the gangway is being renewed or upgraded.

7.3.2.9. Information

Compliance with the requirements of Clause 4.2.2.8.2.2 in respect of route information is not mandatory at renewal or upgrade. However, where an automated route information system is installed as part of a renewal or upgrade programme, it shall comply with the requirements of this clause.

Compliance with the other parts of Clause 4.2.2.8 shall be mandatory whenever signage or interior finishes are renewed or upgraded.

7.3.2.10. Height Changes

Compliance with the requirements of Clause 4.2.2.9 is not mandatory at renewal or upgrade, with the exception that a colour contrasting warning band on step nosings shall be provided when tread surface materials are renewed or upgraded.

7.3.2.11. Handrails

Compliance with the requirements of Clause 4.2.2.10 is only mandatory where existing handrails are being renewed or upgraded.

7.3.2.12. Wheelchair Accessible sleeping accommodation

Compliance with the requirement to provide Wheelchair Accessible sleeping accommodation is only mandatory when existing sleeping accommodation is being renewed or upgraded.

The provision of emergency contact devices in the Wheelchair Accessible sleeping accommodation is not mandatory if the vehicle does not have an electrical communications system that can be adapted to include such a device.

7.3.2.13. Step positions, steps and boarding aids

Compliance with the requirements of Clause 4.2.2.12 is not mandatory at renewal or upgrade, with the exception that if moveable steps or other integral boarding aids are fitted, they shall comply with the relevant sub-clauses in this section of the TSI.

However, if a wheelchair space in accordance with Clause 4.2.23 is created at renewal or upgrade, then it shall be mandatory to provide some form of boarding aid in accordance with Clause 4.2.2.12.4.

The responsible Infrastructure Manager (or Station Manager(s) if they are the responsible entities) and Railway Undertaking shall make agreements in accordance with Art.10.5 of Directive 91/440/EC as lastly modified by Directive 2004/51/EC, before the putting into service of the renewed or upgraded Rolling Stock, in order to establish which party is responsible for provision of boarding aids where necessary (Clause 4.2.2.12.4). The Infrastructure Manager (or Station Manager(s) and Railway Undertaking shall ensure that the division of responsibilities they agree is the most viable overall solution.

7.4. Specific cases

7.4.1. General

The following special provisions are permitted in the specific cases below.

These specific cases belong to two categories: the provisions apply either permanently (case 'P'), or temporarily (case 'T'). In temporary cases, it is recommended that the Member States concerned should conform with the relevant subsystem either by 2010 (case 'T1'), an objective set out in Decision No 1692/96/EC of the European Parliament and of the Council of 23 July 1996 on Community guidelines for the development of the trans-European transport network, or by 2020 (case 'T2').

7.4.1.1. Platform height

Denmark 'P'

It is permitted for the height of the platform to be 920 mm above the running surface for S-Bahn services.

France 'P'

It is permitted for the height of the platform to be 920 mm above the running surface for Ile-de-France network.

Germany 'P'

It is permitted for the height of the platform to be 960 mm above the running surface for S-Bahn services.

Great Britain, Northern Ireland and Eire 'P'

It is permitted for the height of the platform to be 915 mm above the running surface.

Lithuania, Latvia and Estonia 'P'

For conventional rail infrastructure only, it is permitted for the height of the platform to be 200 mm or 1 100 mm (+ 20 mm, - 50 mm) above the running surface.

Poland 'P'

It is permitted for the height of the platform to be 960 mm above the running surface for S-Bahn services'

Portugal 'P'

For all existing conventional rail infrastructure in Portugal, it is permitted for the height of the platform to be 900 mm above the running surface.

In stations and stops without commuter traffic services it is permitted for the height of the platform to be 685 mm above the running surface.

Note: The design of entrance door threshold of new rolling stock (suburban and main line) shall be optimised for access from platforms with height of 900 mm.

Spain 'P'

It is permitted for the height of the platform to be 680 mm above the running surface for dedicated commuter or regional traffic platforms.

Sweden 'P'

It is permitted for the height of the platform to be 580 mm and 730 mm above the running surface.

The Netherlands 'P'

It is permitted for the height of the platform to be 840 mm above the running surface.

7.4.1.2. Platform offset

Eire 'P'

On straight and level track $b_{q0} = 1\,561$ mm.

Great Britain 'P'

The platform offset:

Status: This is the original version (as it was originally adopted).

At straight and level platforms.

$\infty \geq R \geq 360$	$360 \geq R \geq 160$
$b_{q0} = 1\,447,5$	$b_{q0} = 1375,5 + \frac{26000}{R}$

For the lines operated with (Class 373) Eurostar and lines where freight containers of 2,6 m operate.

$\infty \geq R \geq 360$	$360 \geq R \geq 160$
$b_{q0} = 1\,477,5$	$b_{q0} = 1405,5 + \frac{26000}{R}$

For the lines where freight containers of 2,6 m operate.

	$\infty \geq R \geq 500$	$500 \geq R \geq 160$
Internal side of the curve	$b_{q0} = 1\,447,5$	$b_{q0} = 1381,5 + \frac{33000}{R}$
	$\infty \geq R \geq 360$	$360 \geq R \geq 160$
External side of the curve	$b_{q0} = 1\,447,5$	$b_{q0} = 1375,5 + \frac{26000}{R}$

For platform heights of 550 mm and 760 mm the offset shall be:

Belgium 'P'

$$b_{q0} = 1650 + \frac{5000}{R}$$

in curve with a radius R such as $1\,000 \leq R < \infty$ (m)

$$b_{q0} = 1650 + \frac{26470}{R} - 21,5$$

in curve with a radius R such as $R < 1\,000$ (m)

Italy 'P'

For platform heights of 550 mm

$$b_{q0} = 1650 + \frac{3750}{R} - 11,5$$

Finland 'P'

$$b_{q0} = 1800 + \frac{36000}{R}$$

Lithuania, Latvia, Estonia 'P'

For conventional rail infrastructure only:

For platform heights of 200 mm $b_{q0} = 1\,745$ mm (+ 30 mm, - 25 mm).

For platform heights of 1 100 mm $b_{q0} = 1\,920$ mm (+ 30 mm, - 25 mm).

Northern Ireland 'P'

On straight and level track $b_{q0} = 1\,560$ mm.

Poland 'P'

$$b_{q0} = 1725 + \frac{36000}{R}$$

Portugal ‘P’

Applicable to all existing conventional rail infrastructure only.

Track gauge (*nominal*): 1 668 mm

For platform heights (*h*) of 900 mm ($700\text{ mm} < h \leq 1\ 170\text{ mm}$)

$$b_{q0} = 1770 + \frac{31750}{R}$$

For platform heights (*h*) of 685 mm ($400\text{ mm} \leq h \leq 700\text{ mm}$)

$$b_{q0} = 1800 + \frac{23250}{R}$$

Spain ‘P’

Only parts of the network with a track gauge of 1 668 mm

$$b_{q0} = 1720 + \frac{3750}{R}$$

Sweden ‘P’

$$b_{q0}(\text{inside}) = 1670 + \frac{41000}{R}$$

$$b_{q0}(\text{outside}) = 1670 + \frac{31000}{R}$$

7.4.1.3. Access and egress steps

7.4.1.3.1. General

When interoperable Rolling Stock operates to platforms described by the specific cases as detailed in clause 7.4.1.2 for platforms of 550 mm or 760 mm height, the following supplementary value δ_g may be added to the conventional value of δ_h .

The corresponding value b_{q0} is also given in the tables.

Additional value δ_g for straight and level track.

	Belgium ‘P’	Finland ‘P’	Italy ‘P’	Poland ‘P’	Portugal ‘P’ for platforms of 900 mm	Portugal ‘P’ for platforms of 685 mm	Sweden ‘P’	Spain ‘P’	GB ‘P’
δ_g	0	150	11,5	75	+ 120 mm	+ 150 mm	20	70	-202,5
b_{q0}	1 650	1 800	1 661,5	1 725	1 770 mm	1 800 mm	1 670	1 720	1 447,5
For additional dimensions refer to:		7.4.1.3.3			7.4.1.3.4	7.4.1.3.4			7.4.1.3.2

Additional value δ_g for R = 300 m

	Belgium ‘P’	Finland ‘P’	Italy ‘P’	Poland ‘P’	Portugal ‘P’ for	Portugal ‘P’ for	Sweden ‘P’	Spain ‘P’	GB ‘P’
--	--------------------	--------------------	------------------	-------------------	-------------------------	-------------------------	-------------------	------------------	---------------

Status: This is the original version (as it was originally adopted).

					platforms of 900 mm		platforms of 685 mm			
δ_g	54,5	257,5	11,5	195	+ 213 mm	+ 215 mm	Inside 144	Outside 123,5	70	Standard -200 Eurostar -170
b_{q0}	1 716,5	1 920	1 674	1 845	1 876 mm	1 878 mm	Inside 1 806,5	Outside 1 773,5	1 732,5	Standard 1 462,5 Eurostar 1 492,5
For additional dimensions refer to:		7.4.1.3.3			7.4.1.3.4	7.4.1.3.4				7.4.1.3.2

7.4.1.3.2. Specific case for Rolling Stock operating in Great Britain 'P'

As δ_g is a negative value the first step as defined in clause 4.2.2.12.1 will need to be removed when operating on GB lines. Under these circumstances the first useable step on GB lines GB shall comply with the following table:

	δ_h mm	δ_{v+} mm	δ_{v-} mm
on a straight level track	200	230	160
on a track with a curve radius of 300 m, Standard case	200	230	160
on a track with a curve radius of 300 m, Eurostar case	255	230	160

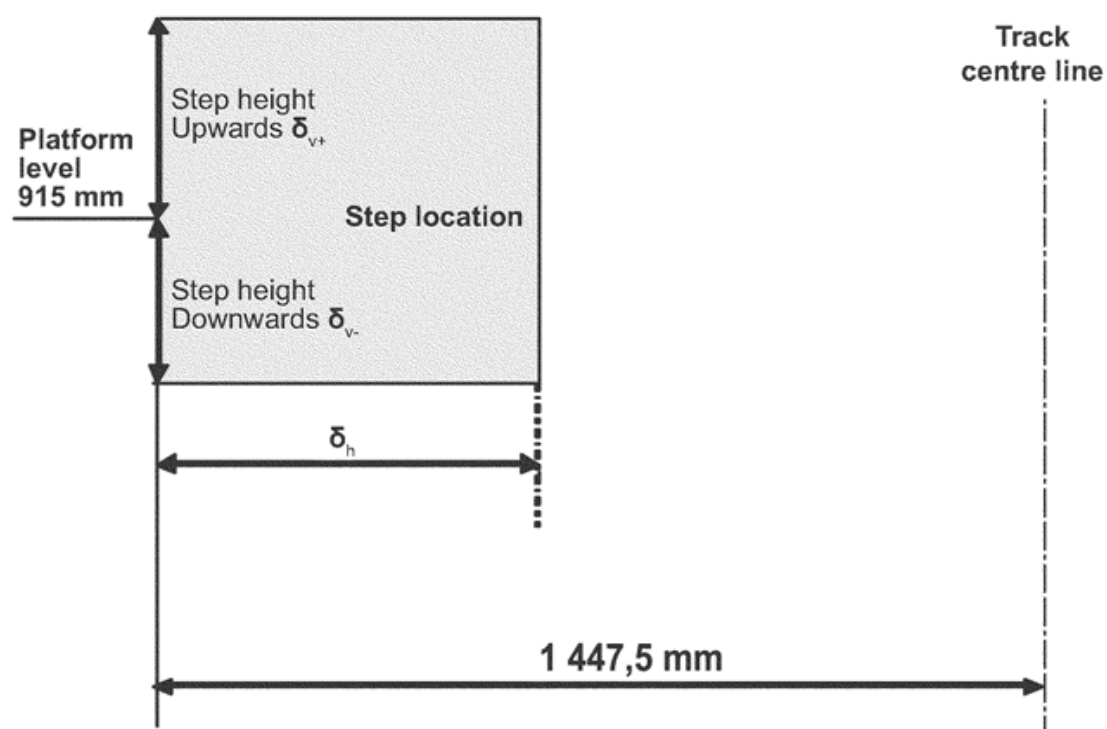

7.4.1.3.3. Specific case for Rolling Stock operating in Finland 'P'

As there is an increase in the value of δ_g a supplementary step will be required for use on lines in Finland. Under these circumstances this first useful step shall comply with the following table and shall be such that the maximum construction gauge of the vehicle meets the requirements of Annex W of the Freight Wagon TSI:

	δ_h mm	δ_{v+} mm	δ_{v-} mm
on a straight level track	200	230	160
on a track with a curve radius of 300 m	410	230	160

Status: This is the original version (as it was originally adopted).

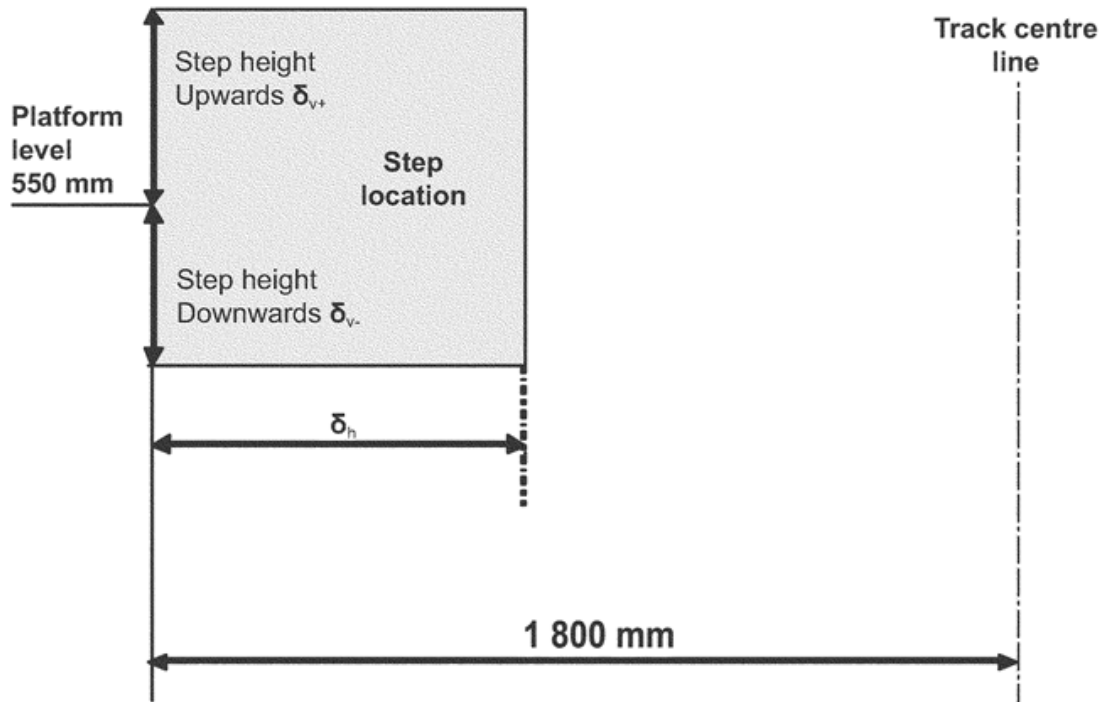

7.4.1.3.4. Specific case for Rolling Stock intending to operate on the existing conventional rail network in Portugal 'P'

As there is an increase in the value of δ_g and the platform levels differs (900 mm and 685 mm) from the standard platform levels (760 mm and 550 mm) will be required for the rolling stock intends for use on lines in Portugal under these circumstances, the first useful step shall comply with the following table and shall be such that the maximum construction gauge of the vehicle meets the requirements of prEN 15273-2:2005 — Railway applications — Gauges — Part 2: Rolling stock gauge — Annex related to Portuguese Kinematics gauges (CP)

The design of entrance door threshold of new rolling stock (commuter and main line) shall be optimised for access from platforms with height of 900 mm.

	δ_h mm	δ_{v+} mm	δ_{v-} mm
on a straight level track	200	230	160
on a track with a curve radius of 300 m	370	230	160

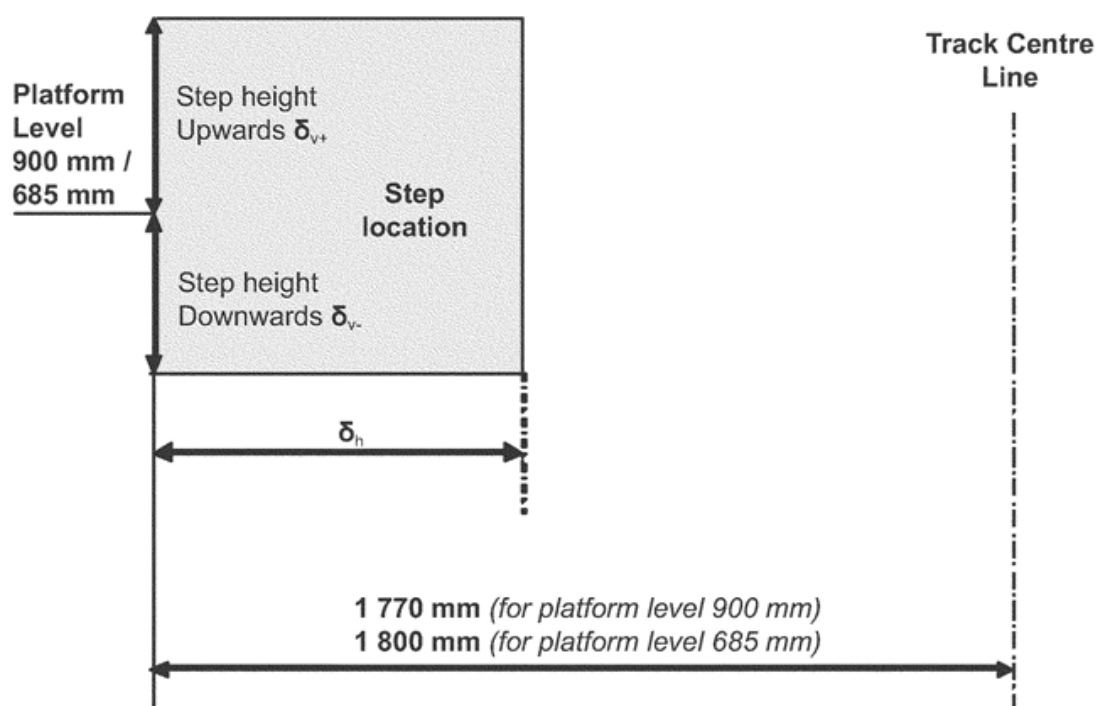

7.4.1.4. Clearways

Specific Case Great Britain, Northern Ireland and Eire 'P'

Due to the structure gauge, track curvature and hence restricted vehicle width the following shall apply:

From the point of entry to the vehicle the minimum clearway to access the priority seats shall comply with the general case.

There shall be no PRM specific requirement for a minimum clearway to access other seats.

7.4.1.5. Audible Door Signals according to chapter 4.2.2.4.1 'P'

Specific case Germany

Due to the lower noise levels of modern trains in Germany the audible signal shall be a minimum of 60 dB L(A_{eq}, T +/- 2. Alternatively audible signals 5 dB above the surrounding noise shall be given.

7.4.1.6. Priority Seats 'P'

Specific cases Germany and Denmark

10 % of all seats shall be priority seats. In trains with a volunteer and compulsory reservation a minimum of 20 % of those priority seats shall have a pictogram, the other 80 % of priority seats can be booked or reserved in advance.

In trains with no possibility of reservation all priority seats shall have a PRM pictogram according to chapter.4.2.2.2.1.1.

7.4.1.7. Obstacle free routes 'P' (Clause 4.1.2.3.1)

Specific case France (Ile de France network only)

New, renewed or upgraded stations with a throughput of less than 5 000 passengers per day (combined total of passengers embarking and disembarking) are not required to meet with the lift and/or ramp aspects of the obstacle-free route requirements if a station stop within 25 km, on the same route, provides an obstacle-free route. In such circumstances, the design of new stations shall incorporate provision for the future installation of a lift and/or ramps to make the station accessible to all categories of PRM.

7.4.1.8. Passenger Numbers

Specific Case Austria 'T1'

Due to the rapid implementation plan of the Austrian authorities, for the duration of this temporary specific case, the passenger number requirements detailed in clauses 7.1.1 and 7.3.1 (Infrastructure) and 4.1.4 (operating rules for obstacle-free routes) shall only apply to infrastructure that is new, upgraded or renewed for stations that have an average daily passenger flow of 2 000 passengers or more, combined embarking and disembarking.

7.5. Rolling Stock operating under national, bilateral, multilateral or international agreements

7.5.1. Existing agreements

Member States shall notify the Commission, within 6 months after the entry into force of this TSI, of the following agreements under which Rolling Stock related to the scope of this TSI (construction, renewal, upgrading, placing in service, operation and management of Rolling Stock as defined in chapter 2 of this TSI) are operated:

- National, bilateral or multilateral agreements between Member States and Railway Undertakings or Infrastructure Managers, agreed on either a permanent or temporary basis, and required due to the very specific or local nature of the intended transport service;
- bilateral or multilateral agreements between Railway Undertakings, Infrastructure Managers or between Safety Authorities, which deliver significant levels of local or regional interoperability;
- international agreements between one or more Member States and at least one third country, or between Railway Undertakings or Infrastructure Managers of Member States and at least one Railway Undertaking or Infrastructure Manager of a third country, which deliver significant levels of local or regional interoperability.

Continued operation/maintenance of Rolling Stock covered by these agreements shall be permitted as far as they do comply with Community legislation.

The compatibility of these agreements with EU legislation including their non-discriminatory character and, in particular, this TSI, will be assessed and the Commission will take the necessary measures such as, for example, the revision of this TSI to include possible specific cases or transitional measures.

7.5.2. Future agreements

Any future agreement or modification of existing agreements, in particular those which include the procurement of rolling stock whose design is not certified in accordance with the TSIs, shall take into account EU legislation and, in particular, this TSI. Member States shall notify the Commission with such agreements/modifications. The same procedure of § 7.5.1 then applies.

7.6. Placing in service of Infrastructure and Rolling Stock

In accordance with Article 16(1) of Directive 2001/16/EC, where compliance with the PRM TSI has been achieved and an EC Declaration of Verification is granted within one Member State for Infrastructure and Rolling Stock, this shall be mutually recognised by all Member States for PRM accessibility issues.

When seeking safety certification under article 10 of directive 2004/49 (Part B of the certificate) or authorisation of placing in service under article 14(1) of directive 2001/16, Railway Undertakings may seek certification/authorisation of placing in service for Infrastructure and Rolling Stock. Rolling Stock may be grouped according to series or type.

However, it shall be verified that where the Infrastructure and Rolling Stock are operated together that they are compatible. This may be done through the use of Infrastructure and Rolling Stock registers.

ANNEXES (TO THE TSI)

Scope: Whole Subsystems Aspect: Accessibility for Persons with Reduced Mobility

Status: This is the original version (as it was originally adopted).

ANNEX A

Reserved

ANNEX B

Reserved

Status: This is the original version (as it was originally adopted).

ANNEX C

Assessment of Maintenance Arrangements: Conformity Assessment Procedure (Annex F4)

ANNEX D

Assessment of interoperability constituents

D.1 Scope

This annex indicates the assessment of conformity and suitability for use for interoperability constituents.

D.2 Characteristics

The characteristics of the interoperability constituents to be assessed in the different phases of design, development and production are marked by X in Table D.1.

TABLE D.1

Assessment of Interoperability Constituents

1	2	3	4	5
Interoperability Constituents and Characteristics to be assessed	Assessment in the following phase			
	Design and development phase			Production phase
	Design review and/or Design examination	Review of manufacturing process	Type test	Verification of conformity to type
4.1.2.11.2 Visual and passenger information equipment	X		X	X
4.1.2.21.2 Boarding devices	X		X	X
4.1.2.4 Tactile pushbuttons	X		X	X
4.1.2.7.2 Baby changing unit	X		X	X
4.1.2.11 Tactile signage	X		X	X
4.1.2.9.2 Ticket vending machines	X		X	X
4.2.2.6 Toilet modules	X		X	X

Status: This is the original version (as it was originally adopted).

4.2.2.8.3 Visual passenger information equipment	X		X	X
4.2.2.3, 4.2.2.6 and 4.2.2.11 Passenger alarm devices	X		X	X
4.2.2.12.3 Boarding devices	X		X	X
4.2.2.4 Pushbuttons	X		X	X
4.2.2.6.3 Baby changing unit	X		X	X
4.2.2.8.1, 4.2.2.8.2 Visual information Annex N and signage	X		X	X

ANNEX E

Assessment of the subsystems

E.1 Scope

This annex indicates the assessment of conformity of the subsystems

E.2 Characteristics and modules

The sub-system characteristics to be assessed in the different phases of design, development and production are marked by X in Table E.1 for Infrastructure subsystem and Table E.2 for Rolling Stock subsystem.

TABLE E.1

Assessment of the Infrastructure subsystem (constructed and supplied as single entity)

1	2	3	4	5
Characteristics to be assessed	Design and development phase	Production phase		
	Design review and/or design examination	Construction assembling, mounting	Assembly (before putting into service)	Validation under full operation conditions
4.1.2.2 Parking facilities for PRM	X		X	
4.1.2.3 Obstacle-free routes				
4.1.2.3.1 General	X		X	
4.1.2.3.2 Route identification	X		X	
4.1.2.4 Doors and entrances	X		X	
4.1.2.5 Floor surfaces	X		X	
4.1.2.6 Transparent obstacles	X		X	
4.1.2.7 Toilets	X		X	

Status: This is the original version (as it was originally adopted).

4.1.2.8	Furniture and free-standing devices	X		X	
4.1.2.9	Ticketing/ Counter or vending machine/ Information counter/ Ticket control machine/ Turnstiles/ Customer Assistance points	X		X	
4.1.2.10	Lighting	X		X	
4.1.2.11	Visual information: signposting, pictograms, dynamic information	X		X	X
4.1.2.12	Spoken information	X		X	X
4.1.2.13	Emergency exits, alarms	X		X	X
4.1.2.14	Geometry of bridges and subways	X		X	
4.1.2.15	Stairs	X		X	
4.1.2.16	Handrails	X		X	
4.1.2.17	Ramps, escalators,	X		X	

	lifts, travelators			
4.1.2.18.1	Platform height	X		X
4.1.2.18.2	Platform offset	X		
4.1.2.18.3	Track layout along the platforms	X		
4.1.2.19	Platform width and edge of platform	X		X
4.1.2.20	End of platform	X		X
4.1.2.21	Boarding aid devices for passengers using wheelchairs	X		X
4.1.2.22	Level track crossing at stations	X		X

TABLE E.2

Assessment of the Rolling Stock subsystem (constructed and supplied as serial products)

1	2	3	4
Characteristics to be assessed	Design and development phase		Production phase
	Design review and/or design examination	Type Test	Routine Test
4.2.2.2 Seats			
4.2.2.2.1 General	X	X	

Status: This is the original version (as it was originally adopted).

4.2.2.2.1 Priority Seats General	X	X	
4.2.2.2.2 Uni-directional seats	X	X	
4.2.2.2.3 Facing seats arrangement	X	X	
4.2.2.3 Wheelchair spaces	X	X	
4.2.2.4 Doors			
4.2.2.4.1 General	X	X	
4.2.2.4.2 Exterior doors	X	X	
4.2.2.4.3 Interior doors	X	X	
4.2.2.5 Lighting		X	
4.2.2.6 Toilets			
4.2.2.6.1 General	X	X	
4.2.2.6.2 Standard toilet	X	X	
4.2.2.6.3 Universal toilet	X	X	
4.2.2.7 Clearways	X	X	
4.2.2.8 Customer Information			
4.2.2.8.1 General	X	X	
4.2.2.8.2 Information (signage)	X	X	
4.2.2.8.2 Information (route description)	X	X	

	and seat reservation))			
4.2.2.9	Height changes	X	X	
4.2.2.10	Handrails	X	X	
4.2.2.11	Wheelchair Accessible sleeping accommodation	X	X	
4.2.2.12 Step position for vehicle access and egress				
4.2.2.12.1	General requirements	X		
4.2.2.12.2	Access/ egress steps	X		
4.2.2.12.3	Moveable steps	X	X	X
4.2.2.12.3	Portable ramps	X	X	
4.2.2.12.3	Semi automatic ramps	X	X	X
4.2.2.12.3	Bridging plates	X	X	X
4.2.2.12.3	On-board lifts	X	X	X

ANNEX F

Procedures for assessment of conformity and suitability for use

F.1. List of the modules

Modules for Interoperability Constituents:

- Module A: Internal production control
- Module A1: Internal design control with product verification
- Module B: Type examination
- Module C: Conformity to type
- Module D: Production quality management system
- Module F: Product verification
- Module H1: Full quality management system
- Module H2: Full quality management system with design examination
- Module V: Type validation by in service experience (Suitability for use)

Modules for Subsystems:

- Module SB: Type examination
- Module SD: Product quality management system
- Module SF: Product verification
- Module SG: Unit verification
- Module SH2: Full quality management system with design examination

Module for Maintenance Arrangements:

- Module Conformity Assessment Procedure

F.2. Modules for Interoperability Constituents

F.2.1. Module A: Internal production control

1. This module describes the procedure whereby the manufacturer or his authorised representative established within the Community, who carries out the obligations laid down in point 2, ensures and declares that the interoperability constituent concerned satisfies the requirements of the TSI that apply to it.
2. The manufacturer shall establish the technical documentation described in point 3.
3. The technical documentation shall enable the conformity of the interoperability constituent with the requirements of the TSI to be assessed. It shall, as far as relevant for such assessment, cover the design, manufacture, maintenance and operation of the interoperability constituent. So far as relevant for the assessment, the documentation shall contain:
 - a general description of the interoperability constituent
 - conceptual design and manufacturing information, for example drawings and schemes of components, subassemblies, circuits, etc.
 - descriptions and explanations necessary for the understanding of the design and manufacturing information, maintenance and the operation of the interoperability constituent
 - the technical specifications including European specifications⁽⁷⁾ with relevant clauses, applied in full or in part,

- description of the solutions adopted to meet the requirements of the TSI, where the European specifications have not been applied in full,
 - results of design calculations made, examinations carried out, etc,
 - test reports.
4. The manufacturer shall take all the measures necessary in order that the manufacturing process ensures compliance of each manufactured interoperability constituent with the technical documentation referenced in point 3 and with the requirements of the TSI that apply to it.
 5. The manufacturer or his authorised representative established within the Community shall draw up a written declaration of conformity for the interoperability constituent. The content of this declaration has to include at least the information indicated in Annex IV (3) and in Article 13 -3 of Directives 01/16/EC. The EC declaration of conformity and the accompanying documents shall be dated and signed.

The declaration shall be written in the same language as the technical documentation and shall contain the following:

- the Directive references (Directives 01/16/EC and other directives to which the interoperability constituent may be subject),
 - the name and address of the manufacturer or his authorised representative established within the Community (give trade name and full address and in the case of an authorised representative also give the trade name of the manufacturer or constructor),
 - description of interoperability constituent (make, type etc.)
 - description of the procedure (module) followed in order to declare conformity,
 - all the relevant descriptions met by the interoperability constituent and in particular its conditions of use,
 - reference to this TSI and to any other applicable TSI, and where appropriate reference to European specifications,
 - identification of the signatory empowered to enter into commitments on behalf of the manufacturer or of his authorised representative established within the Community.
6. The manufacturer or his authorised representative shall keep a copy of the EC declaration of conformity with the technical documentation for a period of 10 years after the last interoperability constituent has been manufactured.

Where neither the manufacturer nor his authorised representative is established within the Community, the obligation to keep the technical documentation available is the responsibility of the person who places the interoperability constituent in the Community market.

7. If additional to the EC declaration of conformity, an EC declaration for suitability for use for the interoperability constituent is required by the TSI, this declaration has to be added after being issued by the manufacturer under the conditions of module V.

F.2.2. Module A1: Internal Design Control with Production Verification

1. This module describes the procedure whereby the manufacturer or his authorised representative established within the Community, who carries out the obligations laid down in point 2, ensures and declares that the interoperability constituent concerned satisfies the requirements of the TSI that apply to it.
2. The manufacturer shall establish the technical documentation described in point 3.
3. The technical documentation shall enable the conformity of the interoperability constituent with the requirements of the TSI to be assessed.

The technical documentation shall also give evidence that the design of the interoperability constituent, already accepted before the implementation of the present TSI, is in accordance with the TSI and that the interoperability constituent has been used in service in the same area of use.

It shall, as far as relevant for such assessment, cover the design, manufacture, maintenance and operation of the interoperability constituent. So far as relevant for the assessment, the documentation shall contain:

- a general description of the interoperability constituent and its conditions of use,
 - conceptual design and manufacturing information, for example drawings and schemes of components, subassemblies, circuits, etc.
 - descriptions and explanations necessary for the understanding of the design and manufacturing information, maintenance and the operation of the interoperability constituent,
 - the technical specifications including European specifications⁽⁸⁾ with relevant clauses, applied in full or in part,
 - descriptions of the solutions adopted to meet the requirements of the TSI, where the European specifications have not been applied in full,
 - results of design calculations made, examinations carried out, etc,
 - test reports,
4. The manufacturer shall take all the measures necessary in order that the manufacturing process ensures compliance of each manufactured interoperability constituent with the technical documentation referenced in point 3 and with the requirements of the TSI that apply to it.
5. The notified body, chosen by the manufacturer, shall carry out the appropriate examinations and tests in order to verify the conformity of the manufactured interoperability constituents with the type described in the technical documentation referenced in point 3 and with the requirement of the TSI. The manufacturer⁽⁹⁾ can choose one of the following procedures:
- 5.1. Verification by examination and testing of every product
- 5.1.1. Each product shall be individually examined and appropriate tests shall be carried out in order to verify the product conformity with the type described in the technical documentation and the requirements of the TSI that apply to it. When a test is not set out in the TSI (or in an European Standard quoted in the TSI), the relevant European Specifications or equivalent tests are applicable
- 5.1.2. The notified body shall draw up a written certificate of conformity for the approved products relating to the tests carried out.
- 5.2. Statistical verification
- 5.2.1. The manufacturer shall present his products in the form of homogeneous lots and shall take all measures necessary in order that the manufacturing process ensures the homogeneity of each lot produced.
- 5.2.2. All interoperability constituents shall be available for verification in the form of homogeneous lots. A random sample shall be drawn from each lot. Each interoperability constituents in a sample shall be individually examined and appropriate tests shall be carried out to ensure the product conformity with the type described in the technical documentation and the requirements of the TSI which apply to it and to determine whether the lot is accepted or rejected. When a test is not set

out in the TSI (or in an European Standard quoted in the TSI), the relevant European Specifications or equivalent tests are applicable

- 5.2.3. The statistical procedure shall use appropriate elements (statistical method, sampling plan etc), depending on the characteristics to be assessed, as specified in the TSI.
- 5.2.4. In the case of accepted lots, the notified body shall draw up a written certificate of conformity relating to the tests carried out. All interoperability constituents in the lot may be placed on the market except those interoperability constituents from the sample, which were found not to be in conformity.
- 5.2.5. If a lot is rejected, the notified body or the competent authority shall take appropriate measures to prevent placing that lot on the market. In the event of frequent rejection of lots the notified body shall suspend the statistical verification.
6. The manufacturer or his authorised representative established within the Community shall draw up the EC declaration of conformity of the interoperability constituent.

The content of this declaration shall include at least the information indicated in Annex IV (3) and in Article 13 -3 of Directive 01/16/EC. The EC declaration of conformity and the accompanying documents shall be dated and signed.

The declaration shall be written in the same language as the technical documentation and shall contain the following:

- the Directive references (Directives 01/16/EC and other directives to which the interoperability constituent may be subject),
- the name and address of the manufacturer or his authorised representative established within the Community (give trade name and full address and in the case of an authorised representative also give the trade name of the manufacturer or constructor),
- description of interoperability constituent (make, type, etc)
- description of the procedure (module) followed in order to declare conformity,
- all of the relevant descriptions met by the interoperability constituent and in particular any conditions of use,
- name and address of notified body (bodies) involved in the procedure followed in respect of conformity and date of certificates together with the duration and conditions of validity of the certificates,
- reference to the TSI and any other applicable TSI and where appropriate reference to European specifications,
- identification of the signatory empowered to enter into commitments on behalf of the manufacturer or of his authorised representative established within the Community.

The certificate to be referred to is the certificate of conformity as mentioned in point 5. The manufacturer or his authorised representative established within the Community shall ensure that he is able to supply the notified body's certificates of conformity on request

7. The manufacturer or his authorised representative shall keep a copy of the EC declaration of conformity with the technical documentation for a period of 10 years after the last interoperability constituent has been manufactured.

Where neither the manufacturer nor his authorised representative is established within the Community, the obligation to keep the technical documentation available is the responsibility of the person who places the interoperability constituent in the Community market.

8. If additional to the EC declaration of conformity, an EC declaration of suitability for use for the interoperability constituent is required by the TSI, this declaration has to be added after being issued by the manufacturer under the conditions of module V.

F.2.3. Module B: Type Examination

1. This module describes that part of the procedure by which a notified body ascertains and attests that a type, representative of the production envisaged, meets the provisions of the TSI that apply to it.
2. The application for the EC type-examination shall be lodged by the manufacturer or his authorised representative established within the Community.

The application shall include:

- the name and address of the manufacturer and also, if the application is lodged by the authorised representative, his name and address,
- a written declaration that the same application has not been lodged with any other notified body,
- the technical documentation, as described in point 3.

The applicant shall place at the disposal of the notified body a specimen, representative of the production envisaged and hereinafter called 'type'.

A type may cover several versions of the Interoperability Constituent provided that the differences between the versions do not affect the provisions of the TSI.

The notified body may request further specimens if needed for carrying out the test programme.

If no type tests are requested within the type examination procedure, and the type is sufficiently defined by the technical documentation, as described in point 3, the notified body shall agree that no specimens are placed at its disposal.

3. The technical documentation shall enable the conformity of the interoperability constituent with the requirements of the TSI to be assessed. It shall, as far as relevant for such assessment, cover the design, manufacture, maintenance and operation of the interoperability constituent.

The technical documentation shall contain:

- a general type-description,
- conceptual design and manufacturing information, for example drawings, schemes of components, sub-assemblies, circuits, etc.,
- descriptions and explanations necessary for the understanding of the design and manufacturing information, maintenance and the operation of the interoperability constituent,
- conditions of integration of the interoperability constituent in its system environment (sub-assembly, assembly, subsystem) and the necessary interface conditions,
- conditions for use and maintenance of the interoperability constituent (restrictions of running time or distance, wear limits etc),
- the technical specifications, including European specifications⁽¹⁰⁾ with relevant clauses, applied in full or in part,
- description of the solutions adopted to meet the requirements of the TSI in cases where the European specifications have not been applied in full,
- results of design calculations made, examinations carried out, etc.,

- test reports,
- 4. The notified body shall:
 - 4.1. examine the technical documentation,
 - 4.2. verify that any specimen(s) required for tests has (have) been manufactured in conformity with the technical documentation, and carry out or have carried out the type tests in accordance with the provisions of the TSI and/or the relevant European specifications,
 - 4.3. where a design review is requested in the TSI, perform an examination of the design methods, the design tools and the design results to evaluate their capability to fulfil the requirements for conformity for the interoperability constituent at the completion of the design process,
 - 4.4. where a review of the manufacturing process is requested in the TSI, perform an examination of the manufacturing process devised for manufacturing the interoperability constituent, to evaluate its contribution to product conformity, and/or examine the review carried out by the manufacturer at the completion of the design process,
 - 4.5. identify the elements which have been designed in accordance with the relevant provisions of the TSI and the European specifications as well as the elements which have been designed without applying the relevant provisions of those European Specifications;
 - 4.6. perform or have performed the appropriate examinations and necessary tests in accordance with points 4.2., 4.3. and 4.4. to establish whether, where the manufacturer has chosen to apply the relevant European specifications, these have actually been applied;
 - 4.7. perform or have performed the appropriate examinations and necessary tests in accordance with points 4.2., 4.3. and 4.4. to establish whether, where the relevant European specifications have not been applied, the solutions adopted by the manufacturer meet the requirements of the TSI;
 - 4.8. agree with the applicant the location where the examinations and necessary tests will be carried out.
- 5. Where the type meets the provisions of the TSI, the notified body shall issue a type-examination certificate to the applicant. The certificate shall contain the name and address of the manufacturer, conclusions of the examination, conditions for its validity and the necessary data for identification of the approved type.

The time period of validity shall be no longer than 5 years.

A list of the relevant parts of the technical documentation shall be annexed to the certificate and a copy kept by the notified body.

If the manufacturer or his authorised representative established within the Community is denied a type-examination certificate, the notified body shall provide detailed reasons for such denial.

Provision shall be made for an appeals procedure.

- 6. The applicant shall inform the notified body that holds the technical documentation concerning the type-examination certificate of all modifications to the approved product which may affect the conformity with the requirements of the TSI or the

prescribed conditions for use of the product. In such cases the interoperability constituent shall receive additional approval from the notified body that issued the EC type examination certificate. In this case, the notified body shall perform only those examinations and tests that are relevant and necessary to the changes. The additional approval shall be given either in the form of an addition to the original type-examination certificate, or, by the issue of a new certificate after withdrawal of the old one.

7. If no modifications as in point 6 have been made, the validity of an expiring certificate can be extended for another period of validity. The applicant will apply for such a prolongation by a written confirmation that no such modifications have been made, and the notified body issues a prolongation for another period of validity as in point 5, if no contrary information exists. This procedure can be reiterated.
8. Each notified body shall communicate to the other notified bodies the relevant information concerning the type-examination certificates and additions issued, withdrawn or refused.
9. The other notified bodies shall receive, on request, copies of the type-examination certificates issued and/or their additions. The annexes to the certificates (see § 5) shall be kept at the disposal of the other notified bodies.
10. The manufacturer or his authorised representative established within the Community shall keep with the technical documentation copies of type-examination certificates and their additions for a period of 10 years after the last interoperability constituent has been manufactured. Where neither the manufacturer nor his authorised representative is established within the Community, the obligation to keep the technical documentation available is the responsibility of the person who places the interoperability constituent on the Community market.

F.2.4. Module C: Conformity to Type

1. This module describes that part of the procedure whereby the manufacturer or his authorised representative established within the Community ensures and declares that the interoperability constituent concerned is in conformity with the type as described in the type-examination certificate and satisfies the requirements of the TSI that apply to it.
2. The manufacturer shall take all measures necessary to ensure that the manufacturing process ensures compliance of each manufactured interoperability constituent with the type as described in the EC type examination certificate and with the requirements of the TSI that apply to it.
3. The manufacturer or his authorised representative established within the Community shall draw up an EC declaration of conformity for the interoperability constituent.

The content of this declaration has to include at least the information indicated in Annex IV (3) and in Article 13 -3 of Directive 01/16/EC. The EC declaration of conformity and the accompanying documents shall be dated and signed.

The declaration shall be written in the same language as the technical documentation and shall contain the following:

- the Directive references (Directive 01/16/EC and other directives to which the interoperability constituent may be subject),

- the name and address of the manufacturer or his authorised representative established within the Community (give trade name and full address and in the case of an authorised representative also give the trade name of the manufacturer or constructor),
 - description of interoperability constituent (make, type etc.)
 - description of the procedure (module) followed in order to declare conformity,
 - all the relevant descriptions met by the interoperability constituent and in particular its conditions of use,
 - name and address of notified body (bodies) involved in the procedure followed in respect of type examination conformity and date of the EC type examination certificate (and its additions) together with the duration and conditions of validity of the certificate,
 - reference to the TSI and to any other applicable TSI, and where appropriate reference to European specifications⁽¹¹⁾,
 - identification of the signatory empowered to enter into commitments on behalf of the manufacturer or of his authorised representative established within the Community.
4. The manufacturer or his authorised representative established within the Community shall keep a copy of the EC declaration of conformity for a period of 10 years after the last interoperability constituent has been manufactured.

Where neither the manufacturer nor his authorised representative is established within the Community, the obligation to keep the technical documentation available is the responsibility of the person who places the interoperability constituent on the Community market.

5. If additional to the EC declaration of conformity an EC declaration of suitability for use for the interoperability constituent is required by the TSI, this declaration has to be added after being issued by the manufacturer under the conditions of module V.

F.2.5. Module D: Production Quality Management System

1. This module describes the procedure whereby the manufacturer or his authorised representative established within the Community who satisfies the obligations of point 2 ensures and declares that the interoperability constituent concerned is in conformity with the type as described in the type-examination certificate and satisfies the requirements of the TSI that apply to it.
2. The manufacturer shall operate an approved quality management system for production, final product inspection and testing as specified in point 3 and is subject to monitoring as specified in point 4.
3. Quality management system
 - 3.1. The manufacturer shall lodge an application for assessment of his quality management system with a notified body of his choice, for the interoperability constituents concerned.

The application shall include:

- all relevant information for the product category representative for the interoperability constituents envisaged,
- the documentation concerning the quality management system,
- the technical documentation of the approved type and a copy of the type-examination certificate, issued after the completion of the type examination procedure of module B.
- a written declaration that the same application has not been lodged with any other notified body,

- 3.2. The quality management system shall ensure compliance of the interoperability constituents with the type as described in the type-examination certificate and with the requirements of the TSI that apply to them. All the elements, requirements and provisions adopted by the manufacturer shall be documented in a systematic and orderly manner in the form of written policies, procedures and instructions. The quality management system documentation shall permit a consistent interpretation of the quality programmes, plan, manuals and records.

It shall contain in particular an adequate description of:

- the quality objectives and the organisational structure,
- responsibilities and powers of the management with regard to product quality,
- the manufacturing, quality control and quality management techniques, processes and systematic actions that will be used,
- the examinations, checks and tests that will be carried out before, during and after manufacture, and the frequency with which they will be undertaken,
- the quality records, such as inspection reports and test data, calibration data, qualification reports of the personnel concerned, etc.,
- the means to monitor the achievement of the required product quality and the effective operation of the quality management system.

- 3.3. The notified body assesses the quality management system to determine whether it satisfies the requirements of point 3.2. It presumes compliance with these requirements if the manufacturer implements a quality system for production, final product inspection and testing in respect of the Standard EN/ISO 9001-2000, which take into consideration the specificity of the interoperability constituent for which it is implemented.

When the manufacturer operates a certified quality management system, the notified body shall take this into account in the assessment.

The audit shall be specific for the product category, which is representative for the interoperability constituent. The auditing team shall have at least one member experienced as an assessor in the product technology concerned. The evaluation procedure shall include an inspection visit to the manufacturer's premises.

The decision shall be notified to the manufacturer. The notification shall contain the conclusions of the examination and the reasoned assessment decision.

- 3.4. The manufacturer shall undertake to fulfil the obligations arising out of the quality management system as approved and to uphold it so that it remains adequate and efficient.

The manufacturer or his authorised representative established within the Community shall keep the notified body that has approved the quality management system informed of any intended updating of the quality management system.

The notified body shall evaluate the modifications proposed and decide whether the amended quality management system will still satisfy the requirements of point 3.2 or whether a re-assessment is required.

It shall notify its decision to the manufacturer. The notification shall contain the conclusions of the examination and the reasoned assessment decision.

4. Surveillance of the quality management system under the responsibility of the notified body.
 - 4.1. The purpose of surveillance is to make sure that the manufacturer duly fulfils the obligations arising out of the approved quality management system.
 - 4.2. The manufacturer shall allow the notified body entrance for inspection purposes to the locations of manufacture, inspection and testing, and storage and shall provide it with all necessary information, in particular:
 - the quality management system documentation,
 - the quality records such as inspection reports and tests data, calibration data, qualification reports of the personnel concerned, etc.
 - 4.3. The notified body shall periodically carry out audits to make sure that the manufacturer maintains and applies the quality management system and shall provide an audit report to the manufacturer.

The frequency of the audits shall be at least once a year.

When the manufacturer operate a certified quality management system, the notified body shall take this into account in the surveillance.

- 4.4. Additionally the notified body may pay unexpected visits to the manufacturer. During such visits the notified body may carry out, or cause to be carried out, tests to verify that the quality management system is functioning correctly, if necessary. The notified body shall provide the manufacturer with a visit report and, if a test has taken place, with a test report.
5. Each notified body shall communicate to the other notified bodies the relevant information concerning the quality management system approvals, issued, withdrawn or refused.

The other notified bodies may receive on request copies of the quality management system approvals issued.

6. The manufacturer shall, for a period of 10 years after the last product has been manufactured, keep at the disposal of the national authorities:
 - the documentation referenced to in the second indent of point 3.1,
 - the updating referenced to in the second paragraph of point 3.4,
 - the decisions and reports from the notified body in the final paragraph of points 3.4, 4.3 and 4.4.
7. The manufacturer or his authorised representative established within the Community shall draw up the EC declaration of conformity of the interoperability constituent.

The content of this declaration shall include at least the information indicated in Annex IV (3) and in Article 13 -3 of Directive 01/16/EC. The EC declaration of conformity and the accompanying documents shall be dated and signed.

The declaration shall be written in the same language as the technical documentation and shall contain the following:

- the Directive references (Directive 01/16/EC and other directives to which the interoperability constituent may be subject),

Status: This is the original version (as it was originally adopted).

- the name and address of the manufacturer or his authorised representative established within the Community (give trade name and full address and in the case of an authorised representative also give the trade name of the manufacturer or constructor),
- description of the interoperability constituent (make, type, etc)
- description of the procedure (module) followed in order to declare conformity,
- all of the relevant descriptions met by the interoperability constituent and in particular any conditions of use,
- name and address of notified body (bodies) involved in the procedure followed in respect of conformity and date of certificates together with the duration and conditions of validity of the certificates,
- reference to the TSI and any other applicable TSI and where appropriate reference to European specification⁽¹²⁾,
- identification of the signatory empowered to enter into commitments on behalf of the manufacturer or of his authorised representative established within the Community.

The certificates to be referred to are:

- the quality management system approval indicated in point 3,
 - the type-examination certificate and its additions,
8. The manufacturer or his authorised representative established within the Community shall keep a copy of the EC declaration of conformity for a period of 10 years after the last interoperability constituent has been manufactured.

Where neither the manufacturer nor his authorised representative is established within the Community, the obligation to keep the technical documentation available is the responsibility of the person who places the interoperability constituent on the Community market.

9. If additional to the EC declaration of conformity an EC declaration of suitability for use for the interoperability constituent is requested in the TSI, this declaration has to be added, after being issued by the manufacturer under the conditions of Module V.

F.2.6. Module F: Product Verification

1. This module describes the procedure whereby a manufacturer or his authorised representative established within the Community checks and attests that the interoperability constituent concerned and subject to the provisions of point 3 is in conformity with the type as described in the EC type examination certificate and satisfies the requirements of the TSI that apply to it.
2. The manufacturer shall take all measures necessary in order that the manufacturing process ensures conformity of each interoperability constituent with the type as described in the type-examination certificate and with the requirements of the TSI that apply to it.
3. The notified body shall carry out the appropriate examinations and tests in order to check the conformity of the interoperability constituent with the type as described in the EC type examination certificate and with the requirements of the TSI. The manufacturer⁽¹³⁾ can choose either an examination and testing of every interoperability constituent as specified in point 4 or an examination and testing of interoperability constituents on a statistical basis, as specified in point 5.
4. Verification by examination and testing of every interoperability constituent
 - 4.1. Each product shall be individually examined and appropriate tests shall be carried out in order to verify the product conformity with the type as described in the type-

examination certificate and with the requirements of the TSI that apply to it. When a test is not set out in the TSI, (or in an European Standard quoted in the TSI), the relevant European Specifications⁽¹⁴⁾, or equivalent tests are applicable.

4.2. The notified body shall draw up a written certificate of conformity for the approved products relating to the tests carried out.

4.3. The manufacturer or his authorised representative shall ensure that he is able to supply the notified body's certificates of conformity on request.

5. Statistical verification

5.1. The manufacturer shall present his interoperability constituents in the form of homogeneous lots and shall take all measures necessary in order that the manufacturing process ensures the homogeneity of each lot produced.

5.2. All interoperability constituents shall be available for verification in the form of homogeneous lots. A random sample shall be drawn from each lot. Each interoperability constituents in a sample shall be individually examined and appropriate tests shall be carried out to ensure the product conformity with the type as described in the type-examination certificate and with the requirements of the TSI which apply to it and to determine whether the lot is accepted or rejected. When a test is not set out in the TSI (or in an European Standard quoted in the TSI), the relevant European Specifications or equivalent tests are applicable.

5.3. The statistical procedure shall use appropriate elements (statistical method, sampling plan etc), depending on the characteristics to be assessed, as specified in the TSI.

5.4. In the case of accepted lots, the notified body shall draw up a written certificate of conformity relating to the tests carried out. All interoperability constituents in the lot may be placed on the market except those interoperability constituents from the sample, which were found not to be in conformity.

If a lot is rejected, the notified body or the competent authority shall take appropriate measures to prevent placing of that lot on the market. In the event of frequent rejection of lots the notified body shall suspend the statistical verification.

5.5. The manufacturer or his authorised representative established within the Community shall ensure that he is able to supply the notified body's certificates of conformity on request.

6. The manufacturer or his authorised representative established within the Community shall draw up the EC declaration of conformity of the interoperability constituent.

The content of this declaration shall include at least the information indicated in Annex IV (3) and in Article 13 -3 of Directive 01/16/EC. The EC declaration of conformity and the accompanying documents shall be dated and signed.

The declaration shall be written in the same language as the technical documentation and shall contain the following:

- the Directive references (Directive 01/16/EC and other directives to which the interoperability constituent may be subject),
- the name and address of the manufacturer or his authorised representative established within the Community (give trade name and full address and in the case of an authorised representative also give the trade name of the manufacturer or constructor),
- description of interoperability constituent (make, type, etc)

- description of the procedure (module) followed in order to declare conformity,
- all of the relevant descriptions met by the interoperability constituent and in particular any conditions of use,
- name and address of notified body (bodies) involved in the procedure followed in respect of conformity and date of certificates together with the duration and conditions of validity of the certificates,
- reference to the TSI and any other applicable TSI and where appropriate reference to European specifications,
- identification of the signatory empowered to enter into commitments on behalf of the manufacturer or of his authorised representative established within the Community.

The certificates to be referred to are:

- the type-examination certificate and its additions,
 - the certificate of conformity as mentioned in points 4 or 5.
7. The manufacturer or his authorised representative established within the Community shall keep a copy of the EC declaration of conformity for a period of 10 years after the last interoperability constituent has been manufactured.

Where neither the manufacturer nor his authorised representative is established within the Community, the obligation to keep the technical documentation available is the responsibility of the person who places the interoperability constituent on the Community market.

8. If additional to the EC declaration of conformity an EC declaration of suitability for use for the interoperability constituent is requested in the TSI, this declaration has to be added, after being issued by the manufacturer under the conditions of Module V.

F.2.7. Module H1: Full Quality Management System

1. This module describes the procedure whereby the manufacturer or his authorised representative established within the Community who satisfies the obligations of point 2, ensures and declares that the interoperability constituent concerned satisfies the requirements of the TSI that apply to it.
2. The manufacturer shall operate an approved quality management system for design, production and final product inspection and testing as specified in point 3 and shall be subject to surveillance as specified in point 4.
3. Quality management system
 - 3.1. The manufacturer shall lodge an application for assessment of his quality management system with a notified body of his choice, for the interoperability constituents concerned.

The application shall include:

- all relevant information for the product category representative for the interoperability constituent envisaged,
 - the quality management system's documentation.
 - a written declaration that the same application has not been lodged with any other notified body,
- 3.2. The quality management system shall ensure compliance of the interoperability constituent with the requirements of the TSI that apply to it. All the elements, requirements and provisions adopted by the manufacturer shall be documented in a systematic and orderly manner in the form of written policies, procedures and

instructions. This quality management system documentation shall ensure a common understanding of the quality policies and procedures such as quality programmes, plans, manuals and records.

It shall contain in particular an adequate description of:

- the quality objectives and the organisational structure,
- responsibilities and powers of the management with regard to design and product quality,
- the technical design specifications, including European specifications⁽¹⁵⁾, that will be applied, and, where the European specifications will not be applied in full, the means that will be used to ensure that the requirements of the TSI that apply to the interoperability constituent will be met,
- the design control and design verification techniques, processes and systematic actions that will be used when designing the interoperability constituents pertaining to the product category covered,
- the corresponding manufacturing, quality control and quality management system techniques, processes and systematic actions that will be used,
- the examinations, checks and tests that will be carried out before, during and after manufacture, and the frequency with which they will be undertaken,
- the quality records, such as inspection reports and test data, calibration data, qualification reports of the personnel concerned, etc.,
- the means to monitor the achievement of the required design and product quality and the effective operation of the quality management system.

The quality policies and procedures shall cover in particular the assessment phases as design review, review of manufacturing process and type tests, as they are specified in the TSI, for the different characteristics and performances of the interoperability constituent.

- 3.3. The notified body shall assess the quality management system to determine whether it satisfies the requirements of point 3.2. It presumes compliance with these requirements if the manufacturer implements a quality system for design, production, final product inspection and testing in respect of the Standard EN/ISO 9001-2000, which take into consideration the specificity of the interoperability constituent for which it is implemented.

When the manufacturer operates a certified quality management system, the notified body shall take this into account in the assessment.

The audit shall be specific for the product category, which is representative for the interoperability constituent. The auditing team shall have at least one member experienced as an assessor in the product technology concerned. The evaluation procedure shall include an assessment visit to the manufacturer's premises.

The decision shall be notified to the manufacturer. The notification shall contain the conclusions of the examination and the reasoned assessment decision.

- 3.4. The manufacturer shall undertake to fulfil the obligations arising out of the quality management system as approved and to uphold it so that it remains adequate and efficient.

The manufacturer or his authorised representative established within the Community shall keep the notified body that has approved the quality management system informed of any intended updating of the quality management system.

The notified body shall evaluate the modifications proposed and decide whether the amended quality management system will still satisfy the requirements of point 3.2 or whether a re-assessment is required.

It shall notify its decision to the manufacturer. The notification shall contain the conclusions of the evaluation and the reasoned assessment decision.

4. Surveillance of the quality management system under the responsibility of the notified body
 - 4.1. The purpose of surveillance is to make sure that the manufacturer duly fulfils the obligations arising out of the approved quality management system.
 - 4.2. The manufacturer shall allow the notified body entrance for inspection purposes to the locations of design, manufacture, inspection and testing, and storage, and shall provide it with all necessary information, including particular:
 - the quality management system documentation,
 - the quality records as foreseen by the design part of the quality management system, such as results of analyses, calculations, tests, etc.,
 - the quality records as foreseen by the manufacturing part of the quality management system, such as inspection reports and test data, calibration data, qualification reports of the personnel concerned, etc.
 - 4.3. The notified body shall periodically carry out audits to make sure that the manufacturer maintains and applies the quality management system and shall provide an audit report to the manufacturer. When the manufacturer operates a certified quality management system, the notified body shall take this into account in the surveillance.

The frequency of the audits shall be at least once a year.

- 4.4. Additionally the notified body may pay unexpected visits to the manufacturer. At the time of such visits, the notified body may carry out tests or have them carried out in order to check the proper functioning of the quality management system where necessary. It shall provide the manufacturer with a visit report and, if a test has been carried out, with a test report.
5. The manufacturer shall, for a period of 10 years after the last product has been manufactured, keep at the disposal of the national authorities:
 - the documentation referenced to in the second indent of the second subparagraph of point 3.1,
 - the updating referenced in the second subparagraph of point 3.4,
 - the decisions and reports from the notified body in the final subparagraph of points 3.4, 4.3 and 4.4.
6. Each notified body shall communicate to the other notified bodies the relevant information concerning the quality management system approvals issued, withdrawn or refused.

The other notified bodies may receive on request copies of the quality management system approvals and additional approvals issued.

7. The manufacturer or its authorised representative established within the Community shall draw up the EC Declaration of conformity of the interoperability constituent.

The content of this declaration shall include at least the information indicated in Annex IV (3) and in Article 13 -3 of Directive 01/16/EC. The EC declaration of conformity and the accompanying documents shall be dated and signed.

The declaration shall be written in the same language as the technical documentation and shall contain the following:

- the Directive references (Directive 01/16/EC and other directives to which the interoperability constituent may be subject)
- the name and address of the manufacturer or his authorised representative established within the Community (give trade name and full address and in the case of an authorised representative also give the trade name of the manufacturer or constructor),
- description of interoperability constituent (make, type, etc)
- description of the procedure (module) followed in order to declare conformity,
- all of the relevant descriptions met by the interoperability constituent and in particular its conditions of use,
- name and address of notified body (bodies) involved in the procedure followed in respect of conformity, and date of certificate together with the duration and conditions of validity of the certificate,
- reference to the TSI and to any other applicable TSI and where appropriate to European specifications,
- identification of the signatory empowered to enter into commitments on behalf of the manufacturer or of his authorised representative established within the Community.

The certificate to be referred to is:

- the Quality management system approvals indicated in point 3.
8. The manufacturer or his authorised representative established within the Community shall keep a copy of the EC declaration of conformity for a period of 10 years after the last interoperability constituent has been manufactured.

Where neither the manufacturer nor his authorised representative is established within the Community, the obligation to keep the technical documentation available is the responsibility of the person who places the interoperability constituent on the Community market.

9. If additional to the EC declaration of conformity an EC declaration of suitability for use for the interoperability constituent is requested in the TSI, this declaration has to be added, after being issued by the manufacturer under the conditions of Module V.

F.2.8. Module H2: Full Quality Management System With Design Examination

1. This module describes the procedure whereby a notified body carries out an examination of the design of an interoperability constituent and the manufacturer or his authorised representative established within the Community who satisfies the obligations of point 2 ensures and declares that the interoperability constituent concerned satisfies the requirements of the TSI that apply to it.
2. The manufacturer shall operate an approved quality management system for design, production and final product inspection and testing as specified in point 3 and shall be subject to surveillance as specified in point 4.
3. Quality management system
 - 3.1. The manufacturer shall lodge an application for assessment of his quality management system with a notified body of his choice, for the interoperability constituents concerned.

The application shall include:

- all relevant information for the product category representative for the interoperability constituent envisaged,
- the quality management system's documentation.
- a written declaration that the same application has not been lodged with any other notified body,

3.2. The quality management system shall ensure compliance of the interoperability constituent with the requirements of the TSI that apply to it. All the elements, requirements and provisions adopted by the manufacturer shall be documented in a systematic and orderly manner in the form of written policies, procedures and instructions. This quality management system documentation shall ensure a common understanding of the quality policies and procedures such as quality programmes, plans, manuals and records.

It shall contain in particular an adequate description of:

- the quality objectives and the organisational structure,
- responsibilities and powers of the management with regard to design and product quality,
- the technical design specifications, including European specifications⁽¹⁶⁾, that will be applied, and, where the European specifications will not be applied in full, the means that will be used to ensure that the requirements of the TSI that apply to the interoperability constituent will be met,
- the design control and design verification techniques, processes and systematic actions that will be used when designing the interoperability constituents pertaining to the product category covered,
- the corresponding manufacturing, quality control and quality management system techniques, processes and systematic actions that will be used,
- the examinations, checks and tests that will be carried out before, during and after manufacture, and the frequency with which they will be undertaken,
- the quality records, such as inspection reports and test data, calibration data, qualification reports of the personnel concerned, etc.,
- the means to monitor the achievement of the required design and product quality and the effective operation of the quality management system.

The quality policies and procedures shall cover in particular the assessment phases, such as design review, review of manufacturing processes and type tests, as they are specified in the TSI, for different characteristics and performances of the interoperability constituent.

3.3. The notified body shall assess the quality management system to determine whether it satisfies the requirements of point 3.2. It presumes compliance with these requirements if the manufacturer implements a quality system for design, production, final product inspection and testing in respect of the Standard EN/ISO 9001-2000, which takes into consideration the specificity of the interoperability constituent for which it is implemented.

When the manufacturer operates a certified quality management system, the notified body shall take this into account in the assessment.

The audit shall be specific for the product category, which is representative for the interoperability constituent. The auditing team shall have at least one member experienced as an assessor in the product technology concerned. The evaluation procedure shall include an assessment visit to the manufacturer's premises.

The decision shall be notified to the manufacturer. The notification shall contain the conclusions of the audit and the reasoned assessment decision.

- 3.4. The manufacturer shall undertake to fulfil the obligations arising out of the quality management system as approved and to uphold it so that it remains adequate and efficient.

The manufacturer or his authorised representative established within the Community shall keep the notified body that has approved the quality management system informed of any intended updating of the quality management system.

The notified body shall evaluate the modifications proposed and decide whether the amended quality management system will still satisfy the requirements of point 3.2 or whether a re-assessment is required.

It shall notify its decision to the manufacturer. The notification shall contain the conclusions of the evaluation and the reasoned assessment decision.

4. Surveillance of the quality management system under the responsibility of the notified body

4.1. The purpose of surveillance is to make sure that the manufacturer duly fulfils the obligations arising out of the approved quality management system.

4.2. The manufacturer shall allow the notified body entrance for inspection purposes to the locations of design, manufacture, inspection and testing, and storage, and shall provide it with all necessary information, including:

- the quality management system documentation,
- the quality records as foreseen by the design part of the quality management system, such as results of analyses, calculations, tests, etc.,
- the quality records as foreseen by the manufacturing part of the quality management system, such as inspection reports and test data, calibration data, qualification reports of the personnel concerned, etc.

4.3. The notified body shall periodically carry out audits to make sure that the manufacturer maintains and applies the quality management system and shall provide an audit report to the manufacturer. When the manufacturer operates a certified quality management system, the notified body shall take this into account in the surveillance.

The frequency of the audits shall be at least once a year.

4.4. Additionally the notified body may pay unexpected visits to the manufacturer. At the time of such visits, the notified body may carry out tests or have them carried out in order to check the proper functioning of the quality management system where necessary. It shall provide the manufacturer with a visit report and, if a test has been carried out, with a test report.

5. The manufacturer shall, for a period of 10 years after the last product has been manufactured, keep at the disposal of the national authorities:

- the documentation referenced in the second indent of the second subparagraph of point 3.1,
- the updating referenced to in the second subparagraph of point 3.4,
- the decisions and reports from the notified body in the final subparagraph of points 3.4, 4.3 and 4.4.

6. Design examination

- 6.1. The manufacturer shall lodge an application for examination of the design of the interoperability constituent with a notified body of his choice
- 6.2. The application shall enable the design, manufacture, maintenance and operation of the interoperability constituent to be understood, and shall enable conformity with the requirements of the TSI to be assessed.

It shall include:

- a general type-description,
 - the technical design specifications, including European specifications, with relevant clauses, that have been applied in full or in part,
 - any necessary supporting evidence for their adequacy, in particular where the European specifications and the relevant clauses have not been applied.,
 - the test programme
 - conditions for integration of the interoperability constituent in its system environment (sub-assembly, assembly, subsystem) and the necessary interface conditions,
 - conditions for use and maintenance of the interoperability constituent (restrictions of running time or distance, wear limits etc),
 - a written declaration that the same application has not been lodged with any other notified body,
- 6.3. The applicant shall present the results of tests⁽¹⁷⁾, including type tests when required, carried out by its appropriate laboratory or on their behalf.
 - 6.4. The notified body shall examine the application and assess the results of the tests. Where the design meets the provisions of the TSI that apply to it, the notified body shall issue an EC design examination certificate to the applicant. The certificate shall contain the conclusions of the examination, conditions for its validity, the necessary data for identification of the approved design and, if relevant, a description of the product's functioning.

The time period of validity shall be no longer than 5 years.

- 6.5. The applicant shall keep the notified body that has issued the EC design examination certificate informed of all modifications to the approved design, which may affect the conformity with the requirements of the TSI or the prescribed conditions for use of the interoperability constituent. In such cases the interoperability constituent shall receive additional approval from the notified body that issued the EC design examination certificate. In this case, the notified body shall perform only those examinations and tests that are relevant and necessary to the changes. The additional approval shall be given in the form of an addition to the original EC design examination certificate.
- 6.6. If no modifications as in point 6.4. have been made, the validity of an expiring certificate can be extended for another period of validity. The applicant will apply for such a prolongation by a written confirmation that no such modifications have been made, and the notified body issues a prolongation for another period of validity as in point 6.3. if no contrary information exists. This procedure can be reiterated.
7. Each notified body shall communicate to the other notified bodies the relevant information concerning the quality management system approvals and the EC design examination certificates, which it has issued, withdrawn or refused.

The other notified bodies may receive on request copies of:

- the quality management system approvals and additional approvals issued and

- the EC design examination certificates and additions issued.
8. The manufacturer or his authorised representative established within the Community shall draw up the EC declaration of conformity of the interoperability constituent.

The content of this declaration shall include at least the information indicated in Annex IV (3) and in Article 13 -3 of Directive 01/16/EC. The EC declaration of conformity and its accompanying documents shall be dated and signed.

The declaration shall be written in the same language as the technical documentation and shall contain the following:

- the Directive references (Directive 01/16/EC and other directives to which the interoperability constituent may be subject),
- the name and address of the manufacturer or his authorised representative established within the Community (give trade name and full address and in the case of an authorised representative also give the trade name of the manufacturer or constructor),
- description of interoperability constituent (make, type, etc)
- description of the procedure (module) followed in order to declare conformity,
- all of the relevant descriptions met by the interoperability constituent and in particular any conditions of use,
- name and address of notified body (bodies) involved in the procedure followed in respect of conformity and date of certificates together with the duration and conditions of validity of the certificates,
- reference to the TSI and any other applicable TSI and where appropriate to European specifications,
- identification of the signatory empowered to enter into commitments on behalf of the manufacturer or of his authorised representative established within the Community.

The certificates to be referred to are:

- the quality management system approval and surveillance reports indicated in point 3 and 4,
 - the EC design examination certificate and its additions.
9. The manufacturer or his authorised representative established within the Community shall keep a copy of the EC declaration of conformity for a period of 10 years after the last interoperability constituent has been manufactured.

Where neither the manufacturer nor his authorised representative is established within the Community, the obligation to keep the technical documentation available is the responsibility of the person who places the interoperability constituent on the Community market.

10. If additional to the EC declaration of conformity an EC declaration of suitability for use for the interoperability constituent is requested in the TSI, this declaration has to be added, after being issued by the manufacturer under the conditions of Module V.

F.2.9. Module V: Type-Validation By In Service Experience (Suitability For Use)

1. This module describes that part of the procedure by which a notified body ascertains and attests that a specimen, representative of the production envisaged, meets the provisions of the TSI that apply to it for suitability for use, by type validation as demonstrated through in service experience⁽¹⁸⁾.

2. The manufacturer, or his authorised representative established within the Community, shall lodge the application for the type-validation by in service experience with a notified body of his choice.

The application shall include:

- the name and address of the manufacturer and also, if the application is lodged by the authorised representative, his name and address,
- a written declaration that the same application has not been lodged with any other notified body,
- the technical documentation, as described in point 3,
- the programme for validation by in service experience, as described in point 4,
- the name and address of the company(ies) (infrastructure managers and/or railway enterprises), with which the applicant has obtained an agreement to contribute to a suitability for use assessment by in service experience
- by operating the interoperability constituent in service,
- by monitoring the in service behaviour and
- by issuing a report about in service experience,
- the name and the address of the company undertaking the maintenance of the interoperability constituent during the time period or running distance required for in service experience,
- an EC declaration of conformity for the interoperability constituent and,
- if module B is required in the TSI, an EC type examination certificate,
- if module H2 is required in the TSI, an EC design examination certificate.

The applicant shall place at the disposal of the company(ies), undertaking the operation of the interoperability constituent in service a specimen or a sufficient number of specimens, representative of the production envisaged and hereinafter called 'type'. A type may cover several versions of the interoperability constituent provided that the differences between the versions are all covered by EC declarations of conformity and certificates as mentioned above.

The notified body may request further specimens if needed for carrying out the validation by in service experience to be put in service.

3. The technical documentation shall enable the assessment of the product with the requirements of the TSI. The documentation shall cover the operation of the interoperability constituent, and, as far as relevant for such assessment, cover also the design, manufacture and maintenance.

The technical documentation shall contain

- a general type-description,
- the technical specification, against which the performance and in service behaviour of the interoperability constituent is to be assessed (relevant TSI and/or European Specifications with relevant clauses),
- conditions of integration of the interoperability constituent in its system environment (sub-assembly, assembly, subsystem) and the necessary interface conditions,
- conditions for use and maintenance of the interoperability constituent (restrictions of running time or distance, wear limits etc),
- descriptions and explanations necessary for the understanding of the design, manufacture and operation of the interoperability constituent;

and, as far as is relevant for assessment,

- conceptual design and manufacturing drawings,
- results of design calculations made and examinations carried out,
- test reports.

If the TSI requires further information for the technical documentation, this shall be included.

A list of the European specifications referenced to in the technical documentation, applied in full or in part, shall be attached.

4. The programme for the validation by in service experience shall include:
 - the required performance or behaviour in service of the interoperability constituent under trial,
 - the installation arrangements,
 - the duration of the programme — either time or distance -
 - the operating conditions and the service programme expected,
 - the maintenance programme,
 - the special in service tests, if any, to be performed,
 - the batch size of the specimens — if more than one,
 - the inspection programme (nature, number and frequency of inspections, documentation),
 - criteria for tolerable defects and their impact on the programme,
 - the information to be included in the report of the company operating the interoperability constituent in service (see point 2).
5. The notified body shall:
 - 5.1. Examine the technical documentation and the programme for validation by in service experience,
 - 5.2. Verify that the type is representative and has been manufactured in conformity with the technical documentation,
 - 5.3. Verify that the programme for validation by in service experience is well adapted to assess the required performance and in service behaviour of the interoperability constituent,
 - 5.4. Agree with the applicant the programme and the location where the inspections and necessary tests will be carried out and the body performing the tests (notified body or other competent laboratory),
 - 5.5. Monitor and inspect the progress of in service running, operation and maintenance of the interoperability constituent,
 - 5.6. Evaluate the report, to be issued by the company (ies) (infrastructure managers and/or railway enterprises) operating the interoperability constituent, and all other documentation and information, gained during the procedure (test reports, maintenance experience etc),
 - 5.7. Assess, if the in service behaviour meets the requirements of the TSI.
6. Where the type meets the provisions of the TSI, the notified body shall issue a suitability for use certificate to the applicant. The certificate shall contain the name and address of the manufacturer, conclusions of the validation, conditions for its validity and the necessary data for identification of the approved type.

The time period of validity shall be no longer than 5 years.

A list of the relevant parts of the technical documentation shall be annexed to the certificate and a copy kept by the notified body.

If the applicant is denied a suitability for use certificate, the notified body shall provide detailed reasons for such denial.

Provision shall be made for an appeals procedure.

7. The applicant shall inform the notified body that holds the technical documentation concerning the suitability for use certificate of all modifications to the approved product which shall receive additional approval where such changes may affect the suitability for use or the prescribed conditions for use of the product. In this case, the notified body shall perform only those examinations and tests, that are relevant and necessary to the changes. The additional approval shall be given in the form of an addition to the original suitability for use certificate, or by issue of a new certificate issued after withdrawal of the old certificate.
8. If no modifications as in point 7 have been made, the validity of an expiring certificate can be extended for another period of validity. The applicant will apply for such a prolongation by a written confirmation that no such modifications have been made, and the notified body issues a prolongation for another period of validity as in point 6, if no contrary information exists. This procedure can be reiterated.
9. Each notified body shall communicate to the other notified bodies the relevant information concerning the suitability for use certificates issued, withdrawn or refused.
10. The other notified bodies shall be provided on request with copies of the suitability for use certificates issued and/or their additions. The annexes to the certificates shall be kept at the disposal of the other notified bodies.
11. The manufacturer or his authorised representative established within the Community shall draw up the EC declaration of suitability for use of the interoperability constituent.

The content of this declaration shall include at least the information, indicated in Annex IV (3) and in Article 13 -3 of Directive 01/16/EC. The EC declaration of suitability for use and the accompanying documents shall be dated and signed.

The declaration shall be written in the same language as the technical documentation and shall contain the following:

- the Directive references (Directive 01/16/EC),
- the name and address of the manufacturer or his authorised representative established within the Community (give trade name and full address and in the case of an authorised representative also give the trade name of the manufacturer or constructor),
- description of interoperability constituent (make, type, etc)
- all of the relevant descriptions met by the interoperability constituent and in particular any conditions of use,
- name and address of notified body (bodies) involved in the procedure followed in respect of suitability for use and date of suitability for use certificate together with the duration and conditions of validity of the certificate,
- reference to this TSI and to any other applicable TSI, and where appropriate reference to European specification,

- identification of the signatory empowered to enter into commitments on behalf of the manufacturer or of his authorised representative established within the Community.
12. The manufacturer or his authorised representative established within the Community shall keep a copy of the EC declaration of suitability for use for a period of 10 years after the last interoperability constituent has been manufactured.

Where neither the manufacturer nor his authorised representative is established within the Community, the obligation to keep the technical documentation available is the responsibility of the person who places the interoperability constituent on the Community market.

F.3. Modules for the EC Verification of Subsystems

F.3.1. Module SB: Type Examination

1. This module describes the EC verification procedure whereby a notified body checks and certifies at the request of an contracting entity or its authorised representative established within the Community, that a type of an infrastructure or rolling stock subsystem, representative of the production envisaged,
- complies with this TSI and any other applicable TSI, which demonstrate that the essential requirements⁽¹⁹⁾ of Directive 01/16/EC have been met
 - complies with the other regulations deriving from the Treaty.

The type examination defined by this module could include specific assessment phases — design review, type test or review of manufacturing process, which are specified in the relevant TSI.

2. The contracting entity⁽²⁰⁾ shall lodge an application for EC verification (through type examination) of the subsystem with a notified body of his choice.

The application shall include:

- name and address of the contracting entity or its authorised representative
 - the technical documentation, as described in point 3.
3. The applicant shall place at the disposal of the notified body a specimen of the subsystem⁽²¹⁾, representative of the production envisaged and hereinafter called ‘type’.

A type may cover several versions of the subsystem provided that the differences between the versions do not affect the provisions of the TSI.

The notified body may request further specimens if needed for carrying out the test programme.

If so required for specific test or examination methods and specified in the TSI or in the European specification⁽²²⁾ referenced to in the TSI, a specimen or specimens of a subassembly or assembly or a specimen of the subsystem in a pre-assembled condition shall to be provided.

The technical documentation and specimen(s) shall enable the design, manufacture, installation, maintenance and operation of the subsystem to be understood, and shall enable conformity with the provisions of the TSI to be assessed.

The technical documentation shall include:

- a general description of the subsystem, overall design and structure,
- the infrastructure or rolling stock register, including all information as specified in the TSI
- conceptual design and manufacturing information, for example drawings, schemes of components, subassemblies, assemblies, circuits, etc.,

Status: This is the original version (as it was originally adopted).

- descriptions and explanations necessary for the understanding of the design and manufacturing information, the maintenance and the operation of the subsystem,
- the technical specifications, including European specifications, that have been applied,
- any necessary supporting evidence for the use of the above specifications, in particular where European specifications and the relevant clauses have not been applied in full,
- a list of the interoperability constituents to be incorporated into the subsystem,
- copies of the EC declarations of conformity or suitability for use of interoperability constituents and all the necessary elements defined in annex VI of the directives,
- evidence of conformity with the other regulations deriving from the treaty (including certificates)
- technical documentation regarding the manufacture and the assembly of the subsystem,
- a list of manufacturers, involved in the subsystem's design, manufacturing, assembly and installation,
- conditions for use of the subsystem (restrictions of running time or distance, wear limits etc),
- conditions for maintenance and technical documentation regarding the maintenance of the subsystem
- any technical requirement that shall be taken into account during production, maintenance or operation of the subsystem
- results of design calculations made, examinations carried out, etc.,
- test reports.

If the TSI requires further information for the technical documentation, this shall be included.

4. The notified body shall:
 - 4.1. Examine the technical documentation,
 - 4.2. Verify that the specimen(s) of the subsystem or of assemblies or subassemblies of the subsystem, has (have) been manufactured in conformity with the technical documentation, and carry out or have carried out the type tests in accordance with the provisions of the TSI and the appropriate European specifications. Such manufacture shall be verified using an appropriate assessment module.
 - 4.3. Where a design review is requested in the TSI, perform an examination of the design methods, the design tools and the design results to evaluate their capability to fulfil the requirements for conformity for the subsystem at the completion of the design process
 - 4.4. Identify the elements which have been designed in accordance with the relevant provisions of the TSI and the European specifications as well as the elements which have been designed without applying the relevant provisions of those European specifications;
 - 4.5. Perform or have performed the appropriate examinations and necessary tests in accordance with points 4.2. and 4.3 to establish where the relevant European specifications have been chosen, these have actually been applied;
 - 4.6. Perform or have performed the appropriate examinations and necessary tests in accordance with point 4.2. and 4.3. to establish whether the solutions adopted meet the requirements of the TSI when the appropriate European specifications have not been applied.

- 4.7. Agree with the applicant the location where the examinations and necessary tests will be carried out.
5. Where the type meets the provisions of the TSI, the notified body shall issue a type-examination certificate to the applicant. The certificate shall contain the name and address of the contracting entity and the manufacturer(s) indicated in the technical documentation, conclusions of the examination, conditions for its validity and the necessary data for identification of the approved type.

A list of the relevant parts of the technical documentation shall be annexed to the certificate and a copy kept by the notified body.

If the contracting entity is denied a type-examination certificate, the notified body shall provide detailed reasons for such denial.

Provision shall be made for an appeals procedure.

6. Each notified body shall communicate to the other notified bodies the relevant information concerning the type-examination certificates issued, withdrawn or refused
7. The other notified bodies may receive on request copies of the type-examination certificates issued and/or their additions. The annexes to the certificates shall be kept at the disposal of the other notified bodies.
8. The contracting entity shall keep with the technical documentation copies of type-examination certificates and any additions throughout the service life of the subsystem. It shall be sent to any member state which so requests.
9. During the production phase, the applicant shall inform the notified body that holds the technical documentation concerning the type-examination certificate of all modifications which may affect the conformity with the requirements of the TSI or the prescribed conditions for use of the subsystem. The subsystem shall receive additional approval in such cases. In this case, the notified body shall perform only those examinations and tests, those are relevant and necessary to the changes. This additional approval may be given either in the form of an addition to the original type-examination certificate, or by issue of a new certificate after withdrawal of the old certificate.

F.3.2. Module SD: Production Quality Management System

1. This module describes the EC verification procedure whereby a notified body checks and certifies, at the request of an contracting entity or its authorised representative established within the Community, that an infrastructure or rolling stock subsystem, for which already a type-examination certificate has been issued by a notified body,
 - complies with this TSI and any other applicable TSI, which demonstrate that the essential requirements⁽²³⁾ of Directive 01/16/EC have been met
 - complies with the other regulations deriving from the Treaty,and may be placed in service.
2. The notified body carries out the procedure, under the condition, that:
 - the type examination certificate issued prior to the assessment remains valid for the subsystem subject to the application,
 - the contracting entity⁽²⁴⁾ and the main contractor involved are satisfying the obligations of point 3.

The ‘main contractor’ refers to companies, whose activities contribute to fulfil the essential requirements of the TSI. It concerns:

- the company responsible for the whole subsystem project (including in particular responsibility for subsystem integration),
- other companies only involved in a part of the subsystem project, (performing for example assembly or installation of the subsystem).

It does not refer to manufacturer sub contractors supplying components and interoperability constituents.

3. For the subsystem that is subject of the EC verification procedure, the contracting entity, or the main contractor when employed, shall operate an approved quality management system for manufacture and final product inspection and testing as specified in point 5 and which shall be subject to surveillance as specified in point 6.

When the contracting entity itself is responsible for the whole subsystem project (including in particular responsibility for subsystem integration), or the contracting entity is directly involved in the production (including assembly and installation), it has to operate an approved quality management system for those activities, which shall be subject to surveillance as specified in point 6.

If a main contractor is responsible for the whole subsystem project (including in particular responsibility for subsystem integration), it shall operate in any case an approved quality management system for manufacture and final product inspection and testing, which shall be subject to surveillance as specified in point 6.

4. EC verification procedure

- 4.1. The contracting entity shall lodge an application for EC verification of the subsystem (through production quality management system), including co-ordination of the surveillance of the quality management systems, as under point 5.3 and 6.5. with a notified body of its choice. The contracting entity shall inform the manufacturers involved of this choice and of the application.

The application shall enable the design, manufacture, assembly, installation, maintenance and operation of the subsystem to be understood, and shall enable conformity with the type as described in the type-examination certificate and the requirements of the TSI to be assessed.

4.2. The application shall include:

- name and address of the contracting entity or its authorised representative
- the technical documentation regarding the approved type, including the type examination certificate, as issued after completion of the procedure defined in module SB,

and, if not included in this documentation,

- a general description of the subsystem, its overall design and structure,
- the technical specifications, including European specifications⁽²⁵⁾, that have been applied,
- any necessary supporting evidence for the use of the above specifications, in particular where these European specifications, and the relevant clauses have not been applied in full. This supporting evidence shall include the results of tests carried out by the appropriate laboratory of the manufacturer or on his behalf.
- the infrastructure or rolling stock register, including all information as specified in the TSI,

- the technical documentation regarding the manufacture and the assembly of the subsystem,
 - evidence of conformity to other regulations deriving from the treaty (including certificates) for the production phase
 - a list of the interoperability constituents to be incorporated into the subsystem,
 - copies of the EC declarations of conformity or suitability for use with which the constituents shall be provided, and all the necessary elements defined in annex VI of the directives,
 - a list of manufacturers, involved in the subsystem's design, manufacturing, assembly and installation,
 - the demonstration, that all stages, as mentioned under point 5.2, are covered by quality management systems of the contracting entity, if involved, and/or of the main contractor, and the evidence of their effectiveness,
 - indication of the notified body, responsible for the approval and surveillance of these quality management systems.
- 4.3. The notified body shall first examine the application concerning the validity of the type examination and the type examination certificate.

If the notified body considers the type examination certificate no longer remains valid or is not appropriate and that a new type examination is necessary, it shall justify its decision.

5. Quality management system

- 5.1. The contracting entity, if involved, and the main contractor, when employed, shall lodge an application for assessment of their quality management systems with a notified body of their choice.

The application shall include:

- all relevant information for the subsystem envisaged,
- the quality management system documentation.
- the technical documentation of the approved type and a copy of the type examination certificate, issued after the completion of the type examination procedure of module SB.

For those only involved in a part of the subsystem project, the information to be provided is only that for the relevant part.

- 5.2. For the contracting entity or the main contractor responsible for the whole subsystem project, the quality management systems shall ensure overall compliance of the subsystem with the type as described in the type-examination certificate and overall compliance of the subsystem with the requirements of the TSI. For other contractors, their quality management system(s) has (have) to ensure compliance of their relevant contribution to the subsystem with the type as described in the type-examination certificate and with the requirements of the TSI.

All the elements, requirements and provisions adopted by the applicant(s) shall be documented in a systematic and orderly manner in the form of written policies, procedures and instructions. This quality management system documentation shall ensure a common understanding of the quality policies and procedures such as quality programmes, plans, manuals and records.

It shall contain in particular an adequate description of the following items for all applicant(s):

- the quality objectives and the organisational structure,

- the corresponding manufacturing, quality control and quality management techniques, processes and systematic actions that will be used,
- the examinations, checks and tests that will be carried out before, during and after manufacture, assembly and installation, and the frequency with which they will be carried out,
- the quality records, such as inspection reports and test data, calibration data, qualification reports of the personnel concerned, etc.,

and also for the contracting entity or the main contractor responsible for the whole subsystem project:

- responsibilities and powers of the management with regard to overall subsystem quality, including in particular the subsystem integration management.

The examinations, tests and checking shall cover all of the following stages:

- structure of subsystem, including, in particular, civil-engineering activities, constituent assembly, final adjustment,
- final testing of the subsystem,
- and, where specified in the TSI, the validation under full operation conditions.

- 5.3. The notified body chosen by the contracting entity shall examine, if all stages of the subsystem as mentioned under point 5.2 are sufficiently and properly covered by the approval and surveillance of the quality management system(s) of the applicant(s)⁽²⁶⁾.

If the conformity of the subsystem with the type as described in the type-examination certificate and the compliance of the subsystem with the requirements of the TSI is based on more than one quality management system, the notified body shall examine in particular,

- if the relations and interfaces between the quality management systems are clearly documented
- and if overall responsibilities and powers of the management for the compliance of the whole entire subsystem for the main contractor are sufficiently and properly defined.

- 5.4. The notified body referenced to in point 5.1. shall assess the quality management system to determine whether it satisfies the requirements referenced in point 5.2. It presumes compliance with these requirements if the applicant implements a quality system for production, final product inspection and testing in respect of the Standard EN/ISO 9001-2000, which takes into consideration the specificity of the subsystem for which it is implemented.

When an applicant operates a certified quality management system, the notified body shall take this into account in the assessment.

The audit shall be specific for the subsystem concerned, taking into consideration the specific contribution of the applicant to the subsystem. The auditing team shall have at least one member experienced as an assessor in the subsystem technology concerned. The evaluation procedure shall include an assessment visit to the applicant's premises.

The decision shall be notified to the applicant. The notification shall contain the conclusions of the examination and the reasoned assessment decision.

- 5.5. The contracting entity, if involved, and the main contractor shall undertake to fulfil the obligations arising out of the quality management system as approved and to uphold it so that it remains adequate and efficient.

They shall keep the notified body that has approved the quality management system, informed of any significant change that will affect the fulfilment of the TSI requirements by the subsystem.

The notified body shall evaluate the modifications proposed and decide whether the amended quality management system will still satisfy the requirements referenced in point 5.2 or whether a re-assessment is required.

It shall notify its decision to the applicant. The notification shall contain the conclusions of the examination and the reasoned assessment decision.

6. Surveillance of the quality management system(s) under the responsibility of the notified body

6.1. The purpose of surveillance is to make sure that the contracting entity, if involved, and the main contractor, duly fulfil the obligations arising out of the approved quality management system(s).

6.2. The contracting entity, if involved, and the main contractor shall send to the notified body referenced in point 5.1 (or have sent) all the documents needed for that purpose including the implementation plans and technical records concerning the subsystem (as far as relevant for the specific contribution of the applicants to the subsystem), in particular:

- the quality management system documentation, including the particular means implemented to ensure that:
- for the contracting entity or main contractor, responsible for the whole subsystem project,

overall responsibilities and powers of the management for the compliance of the whole entire subsystem are sufficiently and properly defined,

- for each applicant,

the quality management system is correctly managed for achieving integration at subsystem level,

- the quality records as foreseen by the manufacturing part (including assembly and installation) of the quality management system, such as inspection reports and test data, calibration data, qualification reports of the personnel concerned, etc.

6.3. The notified body shall periodically carry out audits to make sure that the contracting entity, if involved, and the main contractor, maintain and apply the quality management system and shall provide an audit report to them. When those operate a certified quality management system, the notified body shall take this into account in the surveillance.

The frequency of the audits shall be at least once a year, with at least one audit during the time period of performing relevant activities (manufacture, assembly or installation) of the subsystem being the subject of the EC verification procedure mentioned under point 8.

6.4. Additionally the notified body may pay unexpected visits to the relevant sites of the applicant(s). At the time of such visits, the notified body may conduct complete or partial audits and may carry out or cause to be carried out tests, in order to check the proper functioning of the quality management system where necessary. It shall provide the applicant(s) with an inspection report and also, audit and/or test reports, as appropriate.

6.5. The notified body chosen by the contracting entity and responsible for the EC verification, if not carrying out the surveillance of all the quality management system(s) concerned, shall co ordinate the surveillance activities of any other notified body responsible for that task, in order:

Status: This is the original version (as it was originally adopted).

- to be ensured that correct management of interfaces between the different quality management systems relating to subsystem integration has been performed,
- to collect, in liaison with the contracting entity, the necessary elements for the assessment to guarantee the consistency and the overall supervision of the different quality management systems.

This coordination includes the rights of the notified body:

- to receive all documentation (approval and surveillance), issued by the other notified bodies,
 - to witness the surveillance audits in point 6.3,
 - to initiate additional audits as in point 6.4 under its responsibility and together with the other notified bodies.
7. The notified body as referenced in point 5.1. shall have entrance for inspection purposes, audit and surveillance to the locations of building sites, production workshops, locations of assembly and installations, storage areas and where appropriate, prefabrication and testing facilities and, more general, to all premises which it considers necessary in order to carry out its tasks, in accordance with the applicant's specific contribution to the subsystem project.
8. The contracting entity, if involved, and the main contractor shall, for a period of 10 years after the last subsystem has been manufactured, keep at the disposal of the national authorities:
- the documentation referenced in the second indent of the second subparagraph of point 5.1,
 - the updating referenced in the second subparagraph of point 5.5,
 - the decisions and reports from the notified body, which are, referenced in points 5.4, 5.5 and 6.4.
9. Where the subsystem meets the requirements of the TSI, the notified body shall then, based on the type examination and the approval and surveillance of the quality management system(s), draw up the certificate of conformity intended for the contracting entity, who shall in turn draw up the EC declaration of verification intended for the supervisory authority in the Member State within which the subsystem is located and/or operates.

The EC declaration of verification and the accompanying documents shall be dated and signed. The declaration shall be written in the same language of the technical file and shall contain at least the information included in Annex V of the Directive.

10. The notified body chosen by the contracting entity shall be responsible for compiling the technical file that has to accompany the EC declaration of verification. The technical file shall include at least the information indicated in the Art 18 (3) of the Directive, and in particular as follows:
- all necessary documents relating to the characteristics of the subsystem,
 - a list of interoperability constituents incorporated into the subsystem,
 - copies of the EC declarations of conformity and, where appropriate, of the EC declarations of suitability for use, which said constituents shall be provided in accordance with Article 13 of the Directive, accompanied, where appropriate, by the corresponding documents (certificates, quality management system approvals and surveillance documents) issued by the notified bodies,
 - all elements relating to the maintenance, the conditions and limits for use of the subsystem,

- all elements relating to the instructions concerning servicing, constant or routine monitoring, adjustment and maintenance,
 - the type-examination certificate for the subsystem and the accompanying technical documentation as defined in the module SB,
 - evidence of conformity with other regulations deriving from the treaty (including certificates)
 - certificate of conformity of the notified body as mentioned under point 9, accompanied by corresponding verification and/or calculation notes and countersigned by itself, stating that the project complies with the Directive and the TSI, and mentioning, where appropriate, reservations recorded during performance of the activities and not withdrawn. The certificate should also be accompanied by the inspection and audit reports drawn up in connection with the verification, as mentioned in points 6.3 and 6.4 and in particular:
 - the infrastructure or rolling stock register, including all information as specified in the TSI.
11. Each notified body shall communicate to the other notified bodies the relevant information concerning the quality management system approvals issued, withdrawn or refused.

The other notified bodies may receive on request copies of the quality management system approvals issued.

12. The records accompanying the certificate of conformity shall be lodged with the contracting entity.

The contracting entity within the Community shall keep a copy of the technical file throughout the service life of the subsystem and for a further period of three years; it shall be sent to any other Member State which so requests.

F.3.3. Module SF: Product Verification

1. This module describes the EC verification procedure whereby a notified body checks and certifies at the request of an contracting entity or its authorised representative established within the Community, that an infrastructure or rolling stock subsystem, for which a type-examination certificate has already been issued by a notified body,
- complies with this TSI and any other applicable TSI, which demonstrate that the essential requirements⁽²⁷⁾ of Directive 01/16/EC have been met
 - complies with the other regulations deriving from the Treaty

and may be placed into service

2. The contracting entity⁽²⁸⁾ shall lodge an application for EC verification (through product verification) of the subsystem with a notified body of his choice.

The application shall include :

- The name and address of the contracting entity or its authorised representative
 - the technical documentation.
3. Within that part of the procedure the contracting entity checks and attests that the subsystem concerned is in conformity with the type as described in the type examination certificate and satisfies the requirements of the TSI that apply to it.

The notified body shall carrying out the procedure under the condition that the type examination certificate issued prior to the assessment remains valid for the subsystem subject to the application.

4. The contracting entity shall take all measures necessary in order that the manufacturing process (including assembly and integration of interoperability constituents by main contractor⁽²⁹⁾ when employed) ensures conformity of the subsystem with the type as described in the type-examination certificate and with the requirements of the TSI that apply to it.
5. The application shall enable the design, manufacture, installation, maintenance and operation of the subsystem to be understood, and shall enable conformity with the type as described in the type-examination certificate and the requirements of the TSI to be assessed.

The application shall include:

- the technical documentation regarding the approved type, including the type examination certificate, as issued after completion of the procedure defined in module SB,

and, if not included in this documentation,

- a general description of the subsystem, overall design and structure,
- the infrastructure or rolling stock register, including all information as specified in the TSI,
- conceptual design and manufacturing information, for example drawings, schemes of components, subassemblies, assemblies, circuits, etc.,
- the technical documentation regarding the manufacture and the assembly of the subsystem,
- the technical specifications, including European specifications⁽³⁰⁾, that have been applied,
- any necessary supporting evidence for the use of the above specifications, in particular where these European specifications and the relevant clauses have not been applied in full,
- evidence of conformity to other regulations deriving from the treaty (including certificates) for the production phase
- a list of the Interoperability Constituents, to be incorporated into the subsystem,
- copies of the EC declarations of conformity or suitability for use with which said constituents shall be provided and all the necessary elements defined in annex VI of the directives,
- a list of manufacturers involved in the subsystem's design, manufacture, assembly and installation,

If the TSI requires further information for the technical documentation, this shall be included.

6. The notified body shall first examine the application concerning the validity of the type examination and the type examination certificate.

If the notified body considers the type examination certificate no longer remains valid or is not appropriate and that a new type examination is necessary, it shall justify its decision.

The notified body shall carry out the appropriate examinations and tests in order to check the conformity of the subsystem with the type, as described in the type examination certificate

and with the requirements of the TSI. The notified body shall examine and testing of every subsystem manufactured as a serial product, as specified in point 4

7. Verification by examination and testing of every subsystem (as a serial product)
 - 7.1. The notified body shall carry out the tests, examinations and verifications, to ensure conformity of the subsystems, as serial products as provided for in the TSI. The examinations, tests and checking shall extend to the stages as provided for in the TSI.
 - 7.2. Each subsystem (as serial product) shall be individually examined, tested and verified⁽³¹⁾ in order to verify its conformity with the type as described in the type-examination certificate and the requirements of the TSI that apply to it. When a test is not set out in the TSI, (or in a European Standard quoted in the TSI), the relevant European Specifications or equivalent tests are applicable.
8. The notified body shall agree with the contracting entity (and the main contractor) the locations where the tests will be carried out and shall agree that final testing of the subsystem and, whenever required in the TSI, tests or validation under full operating conditions, are carried out by the contracting entity under direct supervision and attendance of the notified body.

The notified body shall have entrance for testing and verification purposes to production workshops, locations of assembly and installations, and where appropriate, prefabrication and testing facilities in order to carry out its tasks as provided for in the TSI.

9. Where the subsystem meets the requirements of the TSI, the notified body shall draw up the certificate of conformity intended for the contracting entity, which in turn draws up the EC declaration of verification intended for the supervisory authority in the Member State where the subsystem is located and/or operates.

These NB activities shall be based on the type examination and the tests, verifications and checks carried out on all serial products as indicated in point 7 and required in the TSI and/or in the relevant European specifications.

The EC declaration of verification and the accompanying documents shall be dated and signed. The declaration shall be written in the same language of the technical file and shall contain at least the information included in Annex V of the Directive.

10. The notified body shall be responsible for compiling the technical file that has to accompany the EC declaration of verification. The technical file shall include at least the information indicated in Art.18 (3) of the Directives, and in particular as follows:
 - all necessary documents relating to the characteristics of the subsystem
 - the infrastructure or rolling stock register, including all information as specified in the TSI,
 - the list of interoperability constituents incorporated into the subsystem,
 - copies of the EC declarations of conformity and, where appropriate, of the EC declarations of suitability for use, which the constituents shall be provided in accordance with Article 13 of the Directive, accompanied, where appropriate, by the corresponding documents (certificates, quality management system approvals and surveillance documents) issued by the notified bodies,
 - all elements relating to the maintenance, the conditions and limits for use of the subsystem,
 - all elements relating to the instructions concerning servicing, constant or routine monitoring, adjustment and maintenance,

- the type-examination certificate for the subsystem and accompanying technical documentation, as defined in the module SB
 - certificate of conformity of the notified body as mentioned in point 9, accompanied by corresponding calculation notes and countersigned by itself, stating that the project complies with the directive and the TSI, and mentioning, where appropriate, reservations recorded during performance of activities and not withdrawn. The certificate should also be accompanied, if relevant, by the inspection and audit reports drawn up in connection with the verification.
11. The records accompanying the certificate of conformity shall be lodged with the contracting entity.

The contracting entity shall keep a copy of the technical file throughout the service life of the subsystem and for a further period of three years; it shall be sent to any other Member State which so requests.

F.3.4. Module SG: Unit verification

1. This module describes the EC verification procedure whereby a notified body checks and certifies, at the request of an contracting entity or its authorised representative established within the Community, that an infrastructure or rolling stock subsystem
 - complies with this TSI and any other applicable TSI, which demonstrate that the essential requirements⁽³²⁾ of Directive 01/16/EC have been met
 - complies with the other regulations deriving from the Treaty,
 and may be placed in service.
2. The contracting entity⁽³³⁾ shall lodge an application for EC verification⁽³³⁾ (through unit verification) of the subsystem with a notified body of his choice.

The application shall include:

- name and address of the contracting entity or its authorised representative
 - the technical documentation.
3. The technical documentation shall enable the design, manufacture, installation and operation of the subsystem to be understood, and shall enable conformity assessment with the requirements of the TSI.

The technical documentation shall include:

- a general description of the subsystem, its overall design and structure,
- the infrastructure or rolling stock register, including all information as specified in the TSI,
- conceptual design and manufacturing information, for example drawings, schemes of components, sub-assemblies, assemblies, circuits, etc.,
- descriptions and explanations necessary for the understanding of the design and manufacturing information, the maintenance and the operation of the subsystem,
- the technical specifications, including European specifications⁽³⁴⁾, that have been applied,
- any necessary supporting evidence for the use of the above specifications, in particular where European specifications and the relevant clauses have not been applied in full,
- a list of the interoperability constituents to be incorporated into the subsystem,

- copies of the EC declarations of conformity or suitability for use with which said constituents shall be provided and all the necessary elements defined in annex VI of the directives,
- evidence of conformity with other regulations deriving from the treaty (including certificates)
- technical documentation regarding the manufacture and the assembly of the subsystem,
- a list of manufacturers involved in the subsystem's design, manufacturing, assembly and installation,
- conditions for use of the subsystem (restrictions of running time or distance, wear limits etc),
- conditions for maintenance and technical documentation regarding the maintenance of the subsystem,
- any technical requirement that shall be taken into account during production, maintenance or operation of the subsystem,
- results of design calculations made, examinations carried out, etc.,
- all other appropriate technical evidences, which can demonstrate that previous checking or tests have been successfully performed, under comparable conditions, by independent and competent bodies

If the TSI requires further information for the technical documentation, this shall be included.

4. The notified body shall examine the application and the technical documentation, and identify the elements which have been designed in accordance with the relevant provisions of the TSI and the European specifications, as well as the elements which have been designed without applying the relevant provisions of those European specifications.

The notified body shall examine the subsystem and verify that the appropriate and necessary tests to establish whether, where the relevant European specifications have been chosen, these have actually been applied or whether the solutions adopted meet the requirements of the TSI when the appropriate European specifications have not been applied.

The examinations, tests and checks shall extend to the following stages as provided for in the TSI:

- overall design
- structure of the subsystem, including, in particular and when relevant, civil-engineering activities, constituent assembly, overall adjustments
- final testing of the subsystem
- and, whenever specified in the TSI, the validation under full operational conditions.

The notified body may take into account evidence of examinations, checking or tests that have been successfully performed, under comparable conditions by other bodies⁽³⁵⁾ or by (or on the behalf of) the applicant, when this is specified by the relevant TSI. The notified body will then decide as to whether it shall use the results of these checks or tests.

The evidences gathered by the notified body shall be suitable and sufficient to show the conformity with the requirement of the TSI and that all required and appropriate checks and tests have been carried out.

Any evidence to be used that originates from other parties shall be considered prior to any tests or checks being carried out, since the notified body may wish to undertake any assessment, witnessing or review of the tests or checks at the time they are performed.

The extent of such other evidence shall be justified by documented analysis using, among others, the factors listed below⁽³⁶⁾. This justification shall be included in the technical file.

In all case the notified body keeps the final responsibility of them.

5. The notified body shall agree with the contracting entity the locations where the tests will be carried out and shall agree that final subsystem tests and, whenever required in the TSI, tests in full operating conditions, are carried out by the contracting entity under direct supervision and attendance of the notified body.
6. The notified body shall have entrance for testing and verification purposes to the locations of design, building sites, production workshops, locations of assembly and installations, and where appropriate, prefabrication and testing facilities in order to carry out its tasks as provided for in the TSI.
7. Where the subsystem meets the requirements of the TSI, the notified body shall then, based on the tests, verifications and checks carried out as required in the TSI and/or in the relevant European specifications, draw up the certificate of conformity intended for the contracting entity, who shall in turn draw up the EC declaration of verification intended for the supervisory authority in the Member State where the subsystem is located and/or operates.

The EC declaration of verification and the accompanying documents shall be dated and signed. The declaration shall be written in the same language as the technical file and shall contain at least the information included in Annex V of the Directive.

8. The notified body shall be responsible for compiling the technical file that has to accompany the EC declaration of verification. The technical file has to include at least the information indicated in Art.18 (3) of the Directive, and in particular as follows:
 - all necessary documents relating to the characteristics of the subsystem
 - the list of interoperability constituents incorporated into the subsystem,
 - copies of the EC declarations of conformity and, where appropriate, of the EC declarations of suitability for use, which the constituents shall be provided in accordance with Article 13 of the Directive, accompanied, where appropriate, by the corresponding documents (certificates, quality management system approvals and surveillance documents) issued by the notified bodies,
 - all elements relating to the maintenance, the conditions and limits for use of the subsystem,
 - all elements relating to the instructions concerning servicing, constant or routine monitoring, adjustment and maintenance,
 - certificate of conformity of the notified body as mentioned in point 7, accompanied by verification and/or corresponding calculation notes and countersigned by itself, stating that the project complies with the directive and the TSI, and mentioning, where appropriate, reservations recorded during performance of activities and not withdrawn; the certificate should also be accompanied, if relevant, by the inspection and audit reports drawn up in connection with the verification,
 - evidence of conformity with other regulations deriving from the treaty (including certificates)
 - the infrastructure or rolling stock register, including all information as specified in the TSI.
9. The records accompanying the certificate of conformity shall be lodged with the contracting entity

The contracting entity shall keep a copy of the technical file throughout the service life of the subsystem and for a further period of three years; it shall be sent to any other Member State which so requests.

F.3.5. Module SH2: Full Quality Management System with Design Examination

1. This module describes the EC verification procedure whereby a notified body checks and certifies, at the request of an contracting entity or its authorised representative established within the Community, that an infrastructure or rolling stock subsystem
 - complies with this TSI and any other applicable TSI, which demonstrate that the essential requirements⁽³⁷⁾ of Directive 01/16/EC have been met
 - complies with the other regulations deriving from the Treaty and may be placed in service
2. The notified body shall carry out the procedure, including a design examination of the subsystem, under the condition, that the contracting entity⁽³⁸⁾ and the main contractor involved are satisfying the obligations of point 3.

The 'main contractor' refers to companies, whose activities contribute to fulfil the essential requirements of the TSI. It concerns the company:

- responsible for the whole subsystem project (including in particular responsibility for subsystem integration),
- other companies involved only in a part of the subsystem project (performing for example design, assembly or installation of the subsystem).

It does not refer to manufacturer sub contractors supplying components and interoperability constituents.

3. For the subsystem that is subject of the EC verification procedure, the contracting entity or the main contractor, when employed, shall operate an approved quality management system for design, manufacture and final product inspection and testing as specified in point 5 and which shall be subject to surveillance as specified in point 6

The main contractor responsible for the whole subsystem project (including in particular responsibility for subsystem integration), shall operate in any case an approved quality management system for design, manufacture and final product inspection and testing, which shall be subject to surveillance as specified in point 6.

In the case that the contracting entity itself is responsible for the whole subsystem project (including in particular responsibility for subsystem integration) or that the contracting entity is directly involved in the design and/or production (including assembly and installation), it shall operate an approved quality management system for those activities, which shall be subject to surveillance as specified in point 6.

Applicants which are only involved in assembly and installation, are permitted to operate only an approved quality management system for manufacture and final product inspection and testing

4. EC verification procedure

- 4.1. The contracting entity shall lodge an application for EC verification of the subsystem (through full quality management system with design examination), including co ordination of surveillance of the quality management systems as in points 5.4. and 6.6., with a notified body of its choice. The contracting entity shall inform the manufacturers involved of his choice and of the application.

- 4.2. The application shall enable the design, manufacture, assembly, installation, maintenance and operation of the subsystem to be understood, and shall enable conformity with the requirements of the TSI to be assessed.

The application shall include:

- name and address of the contracting entity or its authorised representative,
 - the technical documentation including:
 - a general description of the subsystem, overall design and structure,
 - the technical design specifications, including European specifications⁽³⁹⁾, that have been applied,
 - any necessary supporting evidence for the use of the above specifications, in particular where the European specifications and the relevant clauses have not been applied in full,
 - the test programme,
 - the infrastructure or rolling stock register, including all information as specified in the TSI,
 - the technical documentation regarding the manufacture, the assembly of the subsystem,
 - a list of the interoperability constituents to be incorporated into the subsystem,
 - copies of the EC declarations of conformity or suitability for use with which the constituents shall be provided and all the necessary elements defined in annex VI of the directives,
 - evidence of conformity to other regulations deriving from the treaty (including certificates),
 - a list of all manufacturers, involved in the subsystem's design, manufacturing, assembly and installation,
 - conditions for use of the subsystem (restrictions of running time or distance, wear limits etc),
 - conditions for maintenance and technical documentation regarding the maintenance of the subsystem,
 - any technical requirement that shall be taken into account during production, maintenance or operation of the subsystem,
 - the explanation, of how all stages, as mentioned in point 5.2, are covered by quality management systems of the main contractor and/or of the contracting entity, if involved, and the evidence of their effectiveness,
 - indication of the notified body (ies) responsible for the approval and surveillance of these quality management systems.
- 4.3. The contracting entity shall present the results of examinations, checking and tests⁽⁴⁰⁾ including type tests when required, carried out by its appropriate laboratory or on their behalf.
- 4.4. The notified body shall examine the application concerning the design examination and assess the results of the tests. Where the design meets the provisions of the Directive and of the TSI that apply to it shall issue a design examination certificate to the applicant. The certificate shall contain the conclusions of the design examination, conditions for its validity, the necessary data for identification of the design examined and, if relevant, a description of the subsystem's functioning.

If the contracting entity is denied a design examination certificate, the notified body shall provide detailed reasons for such denial.

Provision shall be made for an appeals procedure.

4.5. During the production phase, the applicant shall inform the notified body that holds the technical documentation concerning the design examination certificate of all modifications which may affect the conformity with the requirements of the TSI or the prescribed conditions for use of the subsystem. The subsystem shall receive additional approval in such cases. In this case, the notified body shall perform only those examinations and tests, those are relevant and necessary to the changes. This additional approval may be given either in the form of an addition to the original design examination certificate, or by issue of a new certificate after withdrawal of the old certificate.

5. Quality management system

5.1. The contracting entity, if involved, and the main contractor, when employed, shall lodge an application for assessment of their quality management systems with a notified body of their choice.

The application shall include:

- all relevant information for the subsystem envisaged,
- the quality management system documentation.

For those only involved in a part of the subsystem project, the information to be provided is only that for the relevant part.

5.2. For the contracting entity or the main contractor responsible for the whole subsystem project, the quality management system shall ensure overall compliance of the subsystem with the requirements of the TSI.

The quality management system(s), for other contractors, has (have) to ensure compliance of their relevant contribution to the subsystem, with the requirements of the TSI.

All the elements, requirements and provisions adopted by the applicants shall be documented in a systematic and orderly manner in the form of written policies, procedures and instructions. This quality management system documentation shall ensure a common understanding of the quality policies and procedures such as quality programmes, plans, manuals and records.

The system shall contain in particular an adequate description of the following items:

- for all applicants:
 - the quality objectives and the organisational structure,
 - the corresponding manufacturing, quality control and quality management techniques, processes and systematic actions that will be used,
 - the examinations, checking and tests that will be carried out before, during and after design, manufacture, assembly and installation and the frequency with which they will be carried out,
 - the quality records, such as inspection reports and test data, calibration data, qualification reports of the personnel concerned, etc.,
- for the main contractor, as far as relevant for its contribution to the design of the subsystem:
 - the technical design specifications, including European specifications that will be applied and, where the European specifications will not be applied

Status: This is the original version (as it was originally adopted).

- in full, the means that will be used to ensure that the requirements of the TSI that apply to the subsystem will be met,
- the design control and design verification techniques, processes and systematic actions that will be used when designing the subsystem,
- the means to monitor the achievement of the required design and subsystem quality and the effective operation of the quality management systems in all phases including production.
- and also for the contracting entity or the main contractor responsible for the whole subsystem project:
 - responsibilities and powers of the management with regard to overall subsystem quality, including in particular the subsystem integration management.

The examinations, tests and checking shall cover all of the following stages:

- overall design,
- structure of the subsystem, including, in particular, civil-engineering activities, constituent assembly, final adjustment,
- final testing of the subsystem,
- and, where specified in the TSI, the validation under full operation conditions.

5.3. The notified body chosen by the contracting entity shall examine, if all stages of the subsystem as mentioned in point 5.2 are sufficiently and properly covered by the approval and surveillance of the quality management system(s) of the applicant(s)⁽⁴¹⁾.

If the compliance of the subsystem with the requirements of the TSI is based on more than one quality management system, the notified body shall examine in particular,

- if the relations and interfaces between the quality management systems are clearly documented
- and if overall responsibilities and powers of the management for the compliance of the whole entire subsystem for the main contractor are sufficiently and properly defined.

5.4. The notified body referenced in point 5.1. shall assess the quality management system to determine whether it satisfies the requirements of point 5.2. It presumes compliance with these requirements if the applicant implements a quality system for design, production, final product inspection and testing in respect of the Standard EN/ISO 9001-2000, which takes into consideration the specificity of the subsystem for which it is implemented.

When an applicant operates a certified quality management system, the notified body shall take this into account in the assessment.

The audit shall be specific for the subsystem concerned, taking into consideration the specific contribution of the applicant to the subsystem. The auditing team shall have at least one member experienced as an assessor in the subsystem technology concerned. The evaluation procedure shall include an assessment visit to the applicant's premises.

The decision shall be notified to the applicant. The notification shall contain the conclusions of the examination and the reasoned assessment decision.

5.5. The contracting entity, if involved, and the main contractor shall undertake to fulfil the obligations arising out of the quality management system as approved and to uphold it so that it remains adequate and efficient.

They shall keep the notified body that has approved their quality management system informed of any significant change that will affect the fulfilment of the requirements by the subsystem.

The notified body shall evaluate any modifications proposed and decide whether the amended quality management system will still satisfy the requirements of point 5.2 or whether a re-assessment is required.

It shall notify its decision to the applicant. The notification shall contain the conclusions of the examination and the reasoned assessment decision.

6. Surveillance of the quality management system(s) under the responsibility of the notified body
 - 6.1. The purpose of surveillance is to make sure that the contracting entity, if involved, and the main contractor duly fulfil the obligations arising out of the approved quality management system(s).
 - 6.2. The contracting entity, if involved, and the main contractor shall send the notified body referenced in point 5.1. (or have sent) all the documents needed for that purpose and in particular the implementation plans and technical records concerning the subsystem (as far as relevant for the specific contribution of the applicant to the subsystem), including:
 - the quality management system documentation, including the particular means implemented to ensure that
 - for the contracting entity or the main contractor, responsible for the whole subsystem project,
 - overall responsibilities and powers of the management for the compliance of the whole entire subsystem are sufficiently and properly defined,
 - for each applicant,
 - the quality management system is correctly managed for achieving integration at subsystem level,
 - the quality records as foreseen by the design part of the quality management system, such as results of analyses, calculations, tests, etc.,
 - the quality records as foreseen by the manufacturing part (including assembly, installation and integration) of the quality management system, such as inspection reports and test data, calibration data, competency records of the personnel concerned, etc.
 - 6.3. The notified body shall periodically carry out audits to make sure that the contracting entity, if involved, and the main contractor maintain and apply the quality management system and shall provide an audit report to them. When they operate a certified quality management system, the notified body shall take this into account in the surveillance.

The frequency of the audits shall be at least once a year, with at least one audit during the time period of performing the relevant activities (design, manufacture, assembly or installation) for the subsystem being the subject of the EC verification procedure mentioned in point 4.

- 6.4. Additionally the notified body may pay unexpected visits to the sites mentioned in point 5.2 of the applicant(s). At the time of such visits, the notified body may conduct complete or partial audits and may carry out or cause to be carried out tests in order to check the proper functioning of the quality management system where necessary. It shall provide the applicant(s) with an inspection report and audit and/or test reports as appropriate.

Status: This is the original version (as it was originally adopted).

6.5. The notified body chosen by the contracting entity and responsible for the EC verification, if not carrying out the surveillance of all the quality management system(s) concerned as under point 5, shall co ordinate the surveillance activities of any other notified bodies responsible for that task, in order:

- to be ensured that correct management of interfaces between the different quality management systems relating to subsystem integration has been performed.
- to collect, in liaison with the contracting entity, the necessary elements for the assessment to guarantee the consistency and the overall supervision of the different quality management systems.

This co ordination includes the right of the notified body

- to receive all documentation (approval and surveillance), issued by the other notified body(s),
- to witness the surveillance audits as in point 5.4.,
- to initiate additional audits as in point 5.5. under its responsibility and together with the other notified body(s).

7. The notified body as referenced under point 5.1. shall have entrance for inspection purposes, audit and surveillance to the locations of design, building sites, production workshops, locations of assembly and installation, storage areas and where appropriate, prefabrication or testing facilities and, more general, to all premises which it considers necessary for its task, in accordance with the applicant's specific contribution to the subsystem project.

8. The contracting entity, if involved, and the main contractor shall, for a period of 10 years after the last subsystem has been manufactured, keep at the disposal of the national authorities:

- the documentation referenced in the second indent of the second subparagraph of point 5.1,
- the updating referenced in the second subparagraph of point 5.5,
- the decisions and reports from the notified body which are referenced in the points 5.4, 5.5 and 6.4

9. Where the subsystem meets the requirements of the TSI, the notified body shall then, based on the design examination and the approval and surveillance of the quality management system(s), draw up the certificate of conformity intended for the contracting entity, who shall in turn draw up the EC declaration of verification intended for the supervisory authority in the Member State within which the subsystem is located and/or operates.

The EC declaration of verification and the accompanying documents shall be dated and signed. The declaration shall be written in the same language of the technical file and shall contain at least the information included in Annex V of the Directive.

10. The notified body chosen by the contracting entity shall be responsible for compiling the technical file that has to accompany the EC declaration of verification. The technical file shall include at least the information indicated in Art 18 (3) of The Directive, and in particular as follows:

- all necessary documents relating to the characteristics of the subsystem
- the list of interoperability constituents incorporated into the subsystem,
- copies of the EC declarations of conformity and, where appropriate, of the EC declarations of suitability for use, which the constituents shall be provided in

- accordance with Article 13 of the Directive, accompanied, where appropriate, by the corresponding documents (certificates, quality management system approvals and surveillance documents) issued by the notified bodies,
- evidence of conformity to other regulations deriving from the treaty (including certificates)
 - all elements relating to the maintenance, the conditions and limits for use of the subsystem,
 - all elements relating to the instructions concerning servicing, constant or routine monitoring, adjustment and maintenance
 - certificate of conformity of the notified body as mentioned under point 9, accompanied by corresponding verification and/or calculation notes and countersigned by itself, stating that the project complies with the Directive and the TSI, and mentioning, where appropriate, reservations recorded during performance of the activities and not withdrawn.

The certificate should also be accompanied, if relevant, by the inspection and audit reports drawn up in connection with the verification, as mentioned in points 6.4. and 6.5.;

- the infrastructure or rolling stock register, including all information as specified in the TSI.
11. Each notified body shall communicate to the other notified bodies the relevant information concerning the quality management system approvals and the EC design examination certificates, which it has issued, withdrawn or refused.

The other notified bodies may receive on request copies of:

- the quality management system approvals and additional approvals issued and
- the EC design examination certificates and additions issued

12. The records accompanying the certificate of conformity shall be lodged with the contracting entity

The contracting entity shall keep a copy of the technical file throughout the service life of the subsystem and for a further period of three years; it shall be sent to any other Member State which so requests.

F.4. Assessment of Maintenance Arrangements: Conformity Assessment Procedure

This is an open point.

Status: This is the original version (as it was originally adopted).

ANNEX G

Reserved

ANNEX H

Reserved

Status: This is the original version (as it was originally adopted).

ANNEX I

Reserved

ANNEX J

Reserved

Status: This is the original version (as it was originally adopted).

ANNEX K

Reserved

Status: This is the original version (as it was originally adopted).

ANNEX L

Aspects not specified in the PRM TSI and for which European
Rules apply or notification of National Rules is required

Infrastructure

Parking facilities for PRM (clause 4.1.2.2)
(this includes, but is not limited to: — the number of spaces, access, location, dimensions,
materials, colours, signing and lighting).

Tactile path (clause 4.1.2.3.2)

Slip resistance of floor surfaces (clause 4.1.2.5)

Dimensions and equipment of toilets for wheelchair users (clause 4.1.2.7.1)

Station forecourt lighting (clause 4.1.2.10)

Emergency lighting (clause 4.1.2.10)

Visual information (clause 4.1.2.11.1)

Safety Information and Safety Instructions (clause 4.1.2.11.1)

Warning, prohibition and mandatory actions signs (clause 4.1.2.11.1)

Emergency exits and alarms (clause 4.1.2.13)

Width requirement according to passenger flows (clause 4.1.2.14)

Staircases (clause 4.1.2.15)

Ramps (clause 4.1.2.17)

Escalators (clause 4.1.2.17)

Travelators (clause 4.1.2.17)

Minimum structure gauge (clause 4.1.2.18.2)

Track gauge widening (clause 4.1.2.18.2)

Danger area on platforms definition and tactile marking (clause 4.1.2.19)

Use of level track crossings (clause 4.1.2.22)

Organisation of the transport of wheelchair users by an accessible means between a non
accessible station and the next accessible station on the same route (clause 4.1.4)

Rolling Stock

Customer Information (clause 4.2.2.8.1)

Safety Information and Safety Instructions (clause 4.2.2.8.1)

Warning, prohibition and mandatory actions signs (clause 4.2.2.8.1)

Definitions

Measurement of light reflectance (clause 4.3)

National standard Braille (clause 4.3)

ANNEX M

Transportable Wheelchair

M.1 Scope

This annex identifies the maximum engineering limits for a transportable wheelchair.

M.2 Characteristics

The minimum technical requirements are:

- *Basic Dimensions*
 - Width of 700 mm plus 50 mm min each side for hands when moving
 - Length of 1 200 mm plus 50 mm for feet
- *Wheels*
 - The smallest wheel shall accommodate a gap of dimensions 75 mm horizontal and 50 mm vertical
- *Height*
 - 1 375 mm max including a 95th %ile male occupant
- *Turning circle*
 - 1 500 mm
- *Weight*
 - Fully laden weight of 200 kg for wheelchair and occupant (including any baggage)
- *Obstacle height that can be overcome and ground clearance*
 - Obstacle height that can be overcome 50 mm (max)
 - Ground clearance 60 mm (min)
- *Maximum safe slope on which the wheelchair will remain stable:*
 - Shall have dynamic stability in all directions at an angle of 6 degrees
 - Shall have static stability in all directions (including with brake applied) at an angle of 9 degrees

ANNEX N

PRM Signage

N.1 Scope

This annex identifies specific signage for use on both infrastructure and rolling stock.

N.2 Infrastructure signs

Infrastructure PRM signage dimensions shall be calculated according to the formula:

The minimum size of the enclosure of the written and graphic symbols shall be according to the formula: Reading distance in mm divided by 250, multiplied by 1,25 = frame size in mm, where a frame is utilised.

N.3 Rolling stock signs

The minimum tile size of rolling stock interior PRM signs shall be 60 mm.

The minimum tile size of rolling stock exterior PRM signs shall be 85 mm.

N.4 International wheelchair sign

The sign conforming to the international symbol for the 'provision for the disabled or handicapped persons' in accordance with ISO 7000:2004 symbol 0100, which identifies wheelchair accessible areas, shall meet the following criteria:

Symbol	Background
RAL 9003 Signal white	RAL 5022 Night blue
NCS S 0500-N	NCS S 6030-R70B
C0 M0 Y0 K0	Pantone 274 EC (C100 M100 Y0 K38)

N.5 Inductive loop sign

The sign indicating where inductive loops are fitted shall comply with figure 1 and the following:

Symbol	Background
RAL 9003 Signal white	RAL 5022 Night blue
NCS S 0500-N	NCS S 6030-R70B
C0 M0 Y0 K0	Pantone 274 EC (C100 M100 Y0 K38)



N.6 Call for assistance/call for information sign

The sign indicating where there is a call for assistance or call for information facility shall comply with figure 2 and the following:

Symbol	Background
RAL 9003 Signal white	RAL 5022 Night blue
NCS S 0500-N	NCS S 6030-R70B
C0 M0 Y0 K0	Pantone 274 EC (C100 M100 Y0 K38)



N.7 Emergency call sign

The sign indicating where there is an Emergency call device shall comply with figure 3 and the following:

Symbol	Background
RAL 9003 Signal white	Green
NCS S 0500-N	according
C0 M0 Y0 K0	ISO 3864-1:2002 chapter 11



N.8 Priority seating signs

Symbol	Background
RAL 9003 Signal white	RAL 5022 Night blue
NCS S 0500-N	NCS S 6030-R70B
C0 M0 Y0 K0	Pantone 274 EC (C100 M100 Y0 K38)

Status: This is the original version (as it was originally adopted).



- (1) [OJ L 110, 20.4.2001, p. 1.](#)
- (2) [OJ L 235, 17.9.1996, p. 6.](#)
- (3) [OJ L 235, 17.9.1996.](#) Directive as last amended by Commission Directive 2007/32/EC ([OJ L 141, 2.6.2007, p. 63](#)).
- (4) Regulation of the European Parliament and of the Council on International Rail Passengers' Rights and Obligations, COM(2004)143 final of 3 March 2004.
- (5) [OJ L 315, 3.12.2007, p. 14.](#)
- (6) The normal gauging rules shall also be applied to the footstep. This therefore will preclude the location of the door from some areas of a vehicle.
- (7) The definition of an European specification is indicated in the directives 96/48/EC and 01/16/EC. The guide for application of HS TSIs explains the way to use the European Specifications.
- (8) The definition of an European specification is indicated in the directives 96/48/EC and 01/16/EC. The guide for application of HS TSIs explains the way to use the European Specifications.
- (9) When necessary, the manufacturer's discretion may be limited for specific constituents. In this case, the relevant verification process required for the interoperability constituent is specified in the TSI (or in its annexes).
- (10) The definition of an European specification is indicated in the directives 96/48/EC and 01/16/EC. The guide for application of HS TSIs explains the way to use the European Specifications.
- (11) The definition of an European specification is indicated in the directives 96/48/EC and 01/16/EC. The guide for application of HS TSIs explains the way to use the European Specifications.
- (12) The definition of an European specification is indicated in the directives 96/48/EC and 01/16/EC. The guide for application of HS TSIs explains the way to use the European Specifications.
- (13) The manufacturer's discretion may be limited in specific TSIs.
- (14) The definition of an European specification is indicated in the directives 96/48/EEC and 01/16/EC. The guide for application of HS TSIs explains the way to use the European Specifications.
- (15) The definition of an European specification is indicated in the directives 96/48/EC and 01/16/EC. The guide for application of HS TSIs explains the way to use the European Specifications.
- (16) The definition of an European specification is indicated in the directives 96/48/EC and 01/16/EC. The guide for application of HS TSIs explains the way to use the European Specifications.
- (17) The presentation of the results of the tests can be at the same time as the application or later.
- (18) During the time of in service experience, the IC is not placed on the market.
- (19) The essential requirements are reflected in the technical parameters, interfaces and performance requirements, which are set out in Chapter 4 of the TSI.
- (20) In the module, 'the contracting entity' means 'the subsystem contracting entity, as defined in the directive. or his authorised representative established within the Community'.
- (21) The relevant section of a TSI may define specific requirements in this regard.
- (22) The definition of an European specification is indicated in the directives 96/48/EC and 01/16/EC. The guide for application of HS TSIs explains the way to use the European Specifications.
- (23) The essential requirements are reflected in the technical parameters, interfaces and performance requirements, which are set out in Chapter 4 of the TSI.
- (24) In the module, 'the contracting entity' means 'the subsystem contracting entity, as defined in the directive. or his authorised representative established within the Community'.
- (25) The definition of an European specification is indicated in the directives 96/48/EC and 01/16/EC. The guide for application of HS TSIs explains the way to use the European Specifications.
- (26) For the rolling stock TSI, the notified body may participate to the final in service test of locomotives or train set in the conditions specified in the relevant chapter of the TSI.
- (27) The essential requirements are reflected in the technical parameters, interfaces and performance requirements, which are set out in Chapter 4 of the TSI.

- (28) In the module, ‘the contracting entity’ means ‘the subsystem contracting entity, as defined in the directive. or his authorised representative established within the Community’.
- (29) The ‘main contractor’ refers to companies, whose activities contribute to fulfil essential requirements of the TSI. It concerns the company that can be responsible for the whole subsystem project or other companies only involved in a part of the subsystem project, (performing for example assembly or installation of the subsystem).
- (30) The definition of an European specification is indicated in the directives 96/48/EC and 01/16/EC. The guide for application of HS TSIs explains the way to use the European Specifications.
- (31) In particular, for the rolling stock TSI, the notified body will participate in the final in service testing of rolling stock or train set. This will be indicated in the relevant chapter of the TSI.
- (32) The essential requirements are reflected in the technical parameters, interfaces and performance requirements, which are set out in Chapter 4 of the TSI.
- (33) In the module, ‘the contracting entity’ means ‘the subsystem contracting entity, as defined in the directive. or his authorised representative established within the Community’.
- (34) The definition of an European specification is indicated in the directives 96/48/EC and 01/16/EC. The guide for application of HS TSIs explains the way to use the European Specifications.
- (35) The conditions to entrust checking and tests must be similar than the conditions, respected by a notified body to subcontract activities (see § 6.5 of the Blue Guide on the New Approach).
- (36) The notified body shall investigate the various parts of the subsystem work and establish before, during and on completion of the work:
- the risk and safety implications of the subsystem and its various parts
 - the use of existing equipment and systems:
 - used identically as before
 - used before but adapted for use in the new work
 - the use of existing designs, technologies, materials and production techniques.
 - the arrangements for design, production, testing and commissioning
 - the operational and service duty
 - previous approvals from other competent bodies
 - the accreditations of other involved bodies:
 - it is permissible for the nb to take account of valid accreditation to EN45004, providing that no conflict of interest exists, that accreditation covers the testing being performed and that accreditation is current.
 - where no formal accreditation exists, the nb shall confirm that the systems for control of competence, independence, testing and material handling processes, facilities and equipment and other processes relevant to the contribution to the subsystem are controlled.
 - in all cases, the notified body shall consider the appropriateness of the arrangements and decide the level of witnessing required
 - the use of homogenous lots and systems consistent with module f.
- (37) The essential requirements are reflected in the technical parameters, interfaces and performance requirements, which are set out in Chapter 4 of the TSI.
- (38) In the module, ‘the contracting entity’ means ‘the subsystem contracting entity, as defined in the directive or his authorised representative established within the Community’.
- (39) The definition of an European specification is indicated in the directives 96/48/EC and 01/16/EC. The guide for application of HS TSIs explains the way to use the European Specifications.
- (40) The presentation of the results of the tests can be at the same time as the application or later.
- (41) In particular, for the rolling stock TSI, the notified body will participate in the final in service testing of rolling stock or train set. This will be indicated in the relevant chapter of the TSI.